

NACA RM No. L8J28

**CASE FILE
COPY**

RM No. L8J28

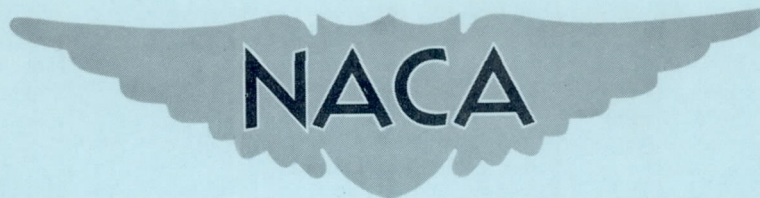

RESEARCH MEMORANDUM

SUMMARY OF RESULTS OF TUMBLING INVESTIGATIONS MADE IN THE
LANGLEY 20-FOOT FREE-SPINNING TUNNEL
ON 14 DYNAMIC MODELS

By

Ralph W. Stone, Jr., and Robert L. Bryant

Langley Aeronautical Laboratory
Langley Field, Va.

**NATIONAL ADVISORY COMMITTEE
FOR AERONAUTICS
WASHINGTON**

December 31, 1948

NATIONAL ADVISORY COMMITTEE FOR AERONAUTICS

RESEARCH MEMORANDUM

SUMMARY OF RESULTS OF TUMBLING INVESTIGATIONS MADE IN THE
LANGLEY 20-FOOT FREE-SPINNING TUNNEL
ON 14 DYNAMIC MODELS

By Ralph W. Stone, Jr., and Robert L. Bryant

SUMMARY

The tumbling characteristics of dynamic models of 14 specific airplane designs investigated in the Langley 20-foot free-spinning tunnel for various loadings and configurations are summarized. For three of the models, tests were made to determine whether recovery from a tumble could be effected by the use of parachutes, and for two of these models, further tests were made to determine whether the pilot could safely escape from a tumbling airplane. The accelerations that would be acting on the pilot during a tumble were computed for several of the tests.

The results indicated that conventional airplanes would not tumble, whereas tailless and tail-first airplanes might tumble, depending upon the amount of static longitudinal stability. The tumbling motion could generally be prevented by forward movement of the center of gravity. The results also indicated that tailless airplanes of low aspect ratio and having their mass distributed chiefly along the fuselage were less likely to tumble than tailless airplanes of high aspect ratio and having the mass distributed chiefly along the wing. It was indicated that lateral and directional controls had little or no effect on tumbling other than to dictate the motion of the airplane after recovery from a tumble. The longitudinal controls and auxiliary lift devices did not appear to have any effect on tumbling, except when the longitudinal stability was marginal. In an emergency, recovery from a tumble may be effected by the use of two parachutes, one attached to each wing tip, when opened simultaneously. The investigation indicated that the accelerations encountered by a pilot in a tumble may be exceptionally dangerous. The results also indicated that, although the pilot will probably not be struck by parts of the airplane in leaving the cockpit of a tailless airplane during a tumble, the accelerations acting on him during the tumble may be high and may prevent him from leaving the cockpit.

INTRODUCTION

The phenomenon of tumbling, a continuous pitching rotation about an axis parallel to the lateral axis of the airplane while descending along an inclined path (see fig. 1), was reported in 1942 for a conventional fighter airplane. Later, a fatal crash occurred during flight tests of a tailless airplane, the cause of which, it was believed, might have been the pilot's failure to recover from a tumble. To date, however, there is no reliable information regarding the tumbling of full-scale aircraft. Investigations conducted in the Langley 20-foot free-spinning tunnel following the implications that such a maneuver as tumbling may be possible have shown that the phenomenon is real and may occur with tailless airplanes but not with conventional airplanes.

The tumble tests reported herein were conducted generally as part of regular spin-test programs for 14 dynamic models. The models represented tailless airplanes having a wide range of sweep angles and aspect ratios as well as several conventional airplanes. For some of the models, tests were made to determine the effects of center-of-gravity variation and of weight variation. Revisions of the geometric configuration of some of the models were also tested, either because a revision was required to improve the spin-recovery or longitudinal trim characteristics or to improve the tumbling characteristics. For three of the models, tests were made to determine whether or not parachutes could be used as an emergency tumble-recovery device, and for two of these models, pilot-escape data were obtained. Approximate calculations were made for some of the models to determine the magnitude of the accelerations which would be acting on the pilot during a tumble.

SYMBOLS

b	wing span, feet
S	wing area, square feet
\bar{c}	mean aerodynamic chord, feet
x/\bar{c}	ratio of distance of center of gravity rearward of leading edge of mean aerodynamic chord to mean aerodynamic chord
z/\bar{c}	ratio of distance between center of gravity and horizontal reference line to mean aerodynamic chord (positive when center of gravity is below line)
m	mass of airplane, slugs

I_X, I_Y, I_Z	moments of inertia about X, Y, and Z body axes, respectively, slug-feet ²
ρ	air density, slugs per cubic foot
μ	airplane relative-density parameter ($m/\rho S b$)
r	distance from airplane center of gravity to pilot's head, feet
α	angle of attack of airplane, measured at the center of gravity, degrees
t	time (taken to be zero the instant the record of motion began), seconds
θ	angular displacement of airplane about its Y-axis, radians ($\theta = 0$ when $t = 0$)
ϵ	angle a line through the pilot's head and the airplane center of gravity makes with the fuselage reference line, degrees
V_T	full-scale velocity of the airplane center of gravity along its trajectory, feet per second
Ω	angular velocity of airplane about its Y-axis, radians per second ($\Omega = \frac{d\theta}{dt}$)
g	acceleration due to gravity, 32.2 feet per second per second
a_c	centripetal acceleration of pilot's head due to Ω , g units
a_o	angular acceleration of airplane about its Y-axis, radians per second per second
a_A	tangential acceleration of pilot's head due to a_o , g units
a	resultant acceleration of pilot's head, g units
a'	component of acceleration directed through long axis of the pilot (positive when pilot is pushed down into seat), g units
a''	component of acceleration directed normal to long axis of the pilot (positive when pilot is pushed against back of seat), g units
δ_r	rudder deflection, degrees

δ_e elevator deflection, degrees

δ_a aileron deflection, degrees

APPARATUS AND METHODS

Model

Dimensional and mass characteristics of the airplanes as represented by the models are presented in tables I and II, respectively, and three-view drawings of the models and changes from the normal model configurations are presented in figures 2 to 15. Each model was ballasted by the use of lead weights to obtain dynamic similarity to the particular airplane it represented at a given test altitude as listed in table II. The parachutes used were of the flat circular type, made of silk, and had a drag coefficient of approximately 0.7 based on the surface area of the canopy when spread out flat. A model pilot was made to scale and ballasted for dynamic similarity of a 200-pound man, with parachute, at the test altitude. For the parachute-recovery and pilot-escape tests, a remote-control mechanism was installed in the model to open the parachute or release the model pilot.

Wind Tunnel and Testing Technique

The tumbling tests were performed in the Langley 20-foot free-spinning tunnel, the operation of which is generally similar to that of the 15-foot free-spinning tunnel, as described in reference 1, except that the launching technique has been changed to launching by hand. For the tumble tests, two methods of launching the models were employed: the model was launched from a nose-up attitude to simulate a whip stall in order to determine whether the model would start tumbling of its own accord, and the model was launched with initial pitching rotation in order to determine whether the model would tumble once the tumbling motion had been started. The simulated whip stall was obtained by holding the model in the air stream with its nose up and simply letting go of the model. The initial pitching rotation given the model was imparted while holding the model in the air stream and forcing it to rotate by applying a pitching moment. The model data presented herein were converted to full-scale values by methods described in reference 1.

The models used for the parachute-recovery tests were so loaded that they would tumble when launched with initial pitching rotation and the parachutes were opened after approximately two complete revolutions of the tumble. The number of additional revolutions, made before recovery was

effected, was recorded by visual observation and by moving pictures of the motion. The pilot-escape tests were conducted in a similar manner except that after approximately two revolutions of the tumble the model pilot was released from the top of the cockpit or escape hatch and his path of motion was observed to determine whether he struck the tumbling model.

Computations of Accelerations

Accelerations at the pilot's head were computed because it appears that the head is most vulnerable as regards accelerations. The resultant acceleration of the pilot's head with respect to the earth is the vectorial sum of the tangential and normal accelerations of the airplane center of gravity along and normal to its trajectory plus the centripetal acceleration of the pilot's head due to the angular velocity of the airplane about its Y-axis plus the tangential acceleration of the pilot's head due to angular acceleration of the airplane about its Y-axis. The accelerations given herein for models 9 and 11 were computed on the assumption that the airplane rotated with constant angular velocity and the tangential and normal accelerations of the center of gravity were negligible. More recent tests with model 13, however, have shown that the models may not rotate with constant angular velocity, although the tangential and normal accelerations of the center of gravity of the models were found to be negligible (less than 1) as originally assumed. The path of motion of the tumbling model was obtained with a stationary motion-picture camera for model 13. The model motion was converted into corresponding full-scale motion and plotted in figure 1. This path of motion was used to determine the angular velocity Ω and the angular acceleration a_o by graphical differentiation of the displacement curves. The centripetal acceleration a_c and the tangential acceleration a_A were then calculated by use of the following formulas:

$$a_c = \Omega^2 \frac{r}{g} = \left(\frac{d\theta}{dt} \right)^2 \frac{r}{g}$$

$$a_A = a_o \frac{r}{g} = \frac{d^2\theta}{dt^2} \frac{r}{g}$$

The slopes $\frac{d\theta}{dt}$ and $\frac{d^2\theta}{dt^2}$ were arbitrarily taken on figure 16 at instances halfway between the recorded intervals of time. These were then resolved into their components directed through and normal to the long axis of the pilot:

$$a' = a_c \sin \epsilon + a_A \cos \epsilon$$

$$a'' = a_c \cos \epsilon + a_A \sin \epsilon$$

The resultant acceleration a is the vectorial sum of the components a' and a'' .

PRECISION

The values of precision presented are the maximum values taken from a composite of values given by all the models. The tumble results presented herein are believed to be true values given by the model within the following limits:

α , degrees	± 1
V, percent	± 5

The values of acceleration given herein are believed to be the true model values with ± 20 percent.

The accuracy of measuring the weight and mass distribution of the models is believed to be within the following limits:

Weight, percent	± 1
Center-of-gravity location, percent \bar{c}	± 1
Moments of inertia, percent	± 5

Controls were set with an accuracy of $\pm 1^\circ$.

Comparison between model and airplane tumble results cannot be made as there exists no full-scale tumbling data. The following interpretation is given for the application of model results to the full-scale airplane from the results of different methods of launching the model: If the model tumbles when launched either with or without initial pitching rotation, it is taken as an indication that the corresponding airplane could tumble, although the airplane probably would be more likely to tumble if the model starts tumbling when launched with no pitching rotation. If the rotation stops after being launched with initial pitching rotation, the results are interpreted to mean that the corresponding airplane will not tumble.

RESULTS AND DISCUSSION

An index to the data is presented in table III. The data are presented in tables IV through XXIII. For convenience, a code of symbols was chosen to represent different results. The symbol A means that the model tumbled; symbol B means that the model would not tumble and dived with slightly

damped oscillations in pitch until striking the safety net; symbol C indicates that the model would not tumble and dived with rapidly damped oscillations in pitch which were completely damped before striking the safety net; and the symbol D means that the model would not tumble and dived with no oscillations in pitch, that is, the oscillations were damped almost instantaneously at the termination of a forced initial rotation. Figures 17 to 20 are reproductions of motion pictures of the motions represented by the symbols A to D, respectively.

For tests of the models in which the ailerons and rudders were deflected and for which the models did not tumble, the motion of the model as it dived in the tunnel was, as expected, dictated by the particular control settings existing. Some of the specific motions which the models performed were aileron rolls, spirals, spins, and so forth. These resulting motions have not been included in the tables.

Effect of Dimensional and Mass Characteristics

Tumbling tests were made for conventional models with normally located center-of-gravity positions (models 1 to 4) and no tendency to tumble was indicated. It thus appears that airplane designs having conventionally located horizontal tails are not likely to tumble irrespective of the external forces acting. Model 9, a tailless model, would not tumble when horizontal tail area, 5 percent of the wing area, was added at approximately 1.5 mean aerodynamic chord lengths rearward of the center of gravity. (See fig. 11 and table XII.) Increasing the horizontal tail area of model 5 (a tail-first, pusher-type airplane), however, was detrimental rather than beneficial which is significant in that it shows that the damping furnished by the horizontal tail area (see fig. 6 and table VIII) is not necessarily the primary factor in determining whether a design will tumble. Instead it appears that the static longitudinal stability characteristics of the model are also primary factors that determine the tumbling characteristics for a given model. Reducing the static longitudinal stability either by rearward movement of the center of gravity or by forward movement of the neutral point increased the tumbling tendency.

None of the tailless models tested would tumble, irrespective of the method of launching, when the center of gravity was located forward so as to provide a high degree of static longitudinal stability. With the center of gravity in an intermediate location, some tailless models would not tumble when launched from a nose-up attitude to simulate a whip stall but would tumble when given forced initial rotation. Further reduction in static stability caused these models to tumble even when launched from a nose-up attitude to simulate a whip stall. (See tables X, XII, XIV, and XV.) Figure 21 illustrates a tumble of model 9 with the elevator full-up when launched from a nose-up attitude to simulate a whip stall, and

figure 22 illustrates the same model with the elevator neutral and launched in the same manner, diving with slightly damped pitching oscillations.

Analysis of the results given in tables II, XI, and XXII, indicates that models having a low aspect ratio and a high pitching inertia parameter (I_Y/mb^2), that is, loaded chiefly along the fuselage, have less tendency to tumble than do other tailless designs. For the models of low aspect ratio and high pitching inertia parameter, more rearward center-of-gravity positions could be tolerated without leading to tumbling than was possible for models of high aspect ratio and low pitching inertia.

Effect of Controls

Study of the effects on tumble characteristics of deflecting longitudinal controls indicated that such controls only had an effect when the static longitudinal stability was marginal. When the center of gravity was located so that the model had a high degree of static longitudinal stability, the model would not tumble when the elevators were deflected full-up, neutral, or full-down. When, however, the center-of-gravity location was such that the model had a very low degree of static longitudinal stability, the model would tumble irrespective of the elevator deflection. When the center-of-gravity location was intermediate, so that the model had marginal static longitudinal stability, the model would either: (1) tumble with positive pitching rotation when the elevators were deflected full-up and would not tumble in either direction for any other elevator deflection, (2) tumble with negative pitching rotation when the elevators were deflected full-down and would not tumble in either direction for any other elevator deflection, or (3) tumble with positive pitching rotation when the elevators were deflected full-up, tumble with negative pitching rotation when the elevators were deflected full-down, or tumble in either direction when the elevators were neutral. It therefore appears that recovery could be effected by full reversal of the elevators for these marginal conditions. Ailerons and rudder, with few exceptions, appeared to have little effect on tumbling.

It is not apparent from the data what effect slats have on tumbling characteristics but it is believed that their effect depends upon the effect they have on static longitudinal stability characteristics. (See tables XII, XIV, XV, and XX.)

Landing flaps and pitch flaps have the same effect as elevators and may assist in stopping the tumble if deflected in conjunction with the elevators against the direction of the rotation.

Parachutes as a Tumble-Recovery Device

The results of tests performed with models 9, 11, and 13 to determine the size, towline length, and attachment location for parachutes as a

tumble-recovery device are presented on tables XIII, XVI, and XXI, respectively. The results generally show that a parachute on each wing will probably be necessary to obtain tumble recovery. When only one parachute was used, the models generally continued to tumble or went into a spin (spinning to the right when the parachute was installed on the right wing tip). The results indicate that the length of the towline must be sufficient to allow the parachute to clear the wing wake in order that the parachutes may operate effectively. Tests of model 9 indicated that the towlines should be attached to the airplane at the wing tips in order for the parachutes to function properly. With the towline attached inboard from the tips on model 9, the towline and parachutes wrapped themselves about the wing and the model continued tumbling. (See table XIII.) The sizes of parachutes required for satisfactory recovery varied for the three models, ranging from 7 to approximately 11 feet. The results of unpublished spin data for model 13 when compared with the results on table XXI show that the size parachutes required for recovery from a spin when two wing-tip parachutes are used will also provide recovery from a tumble. A typical tumble recovery by use of parachutes is shown in figure 23 for model 9.

Accelerations

Computations of accelerations which would be encountered at the pilot's head during a tumble were made for models 9, 11, and 13. Computations for models 9 and 11 were based on an average of the angular velocities encountered during the tumble, whereas those for model 13 allowed for the variation of the rate of tumbling rotation. The computations for model 9 (not presented in tabular form) were made for the tumble which had the fastest average angular velocity. For this tumble, the average tumbling rate of rotation was 6.3 radians per second and the accompanying accelerations were 4.3g units. The results for models 11 and 13 are presented in tables XVIII and XXII, respectively. As indicated in table XVIII for model 11, the average rates of rotation for several tumbles ranged from 6 to 8 radians per second and the corresponding accelerations ranged from 5g to 10g, approximately. The results for model 13 (table XXII) are for a tumble during which the tumbling rate of rotation during one revolution varied from about 1.5 to 4.5 radians per second, full scale. The resultant acceleration varied from approximately 1g to 14g and the component of acceleration along the long axis of the pilot varied from approximately 2g to -3g while that component normal to the long axis varied from approximately 1 to 14. The average angular velocity for the tumble of model 13 was approximately 3 radians per second and based on this average value, an acceleration of only about 4.5g units would be obtained. It appears, therefore, that in order to obtain a true picture of the accelerations, considerations must be given to the variations of tumbling rates of rotation in any one tumble. The distance of the pilot from the center of gravity (about which the rotation may be assumed to be) is also a critical factor being much larger for model 13 than for models 9 and 11.

In order to obtain the true acceleration to which the pilot will react physiologically, the effects of gravity (1g) must be added to the calculated results. Little is known about rapid repetition of exposure to short-period accelerations, but negative accelerations directed through the long axis of the pilot (a') are the least tolerable. Reference 2 indicates that continued exposure to negative accelerations of 3g may cause symptoms of concussion of the brain and that negative accelerations of 5g may result in massive cerebral hemorrhage and possibly death. It is indicated in reference 3, however, that negative accelerations of 3.6g have been tolerated for periods of 7 seconds without any apparent ill effects on the subject. Reference 2 further indicates that positive accelerations (such as, to push the pilot down in the cockpit) of 5g will probably cause temporary loss of vision and that forces of 6g to 7g will cause loss of consciousness. Also it is pointed out that continued accelerations normal to the long axis of the pilot are not well tolerated above 12g's. Although no information is available with regard to tolerance of exposure to repetitious accelerations, it is concluded that the accelerations encountered during a tumble may be exceptionally dangerous to the pilot.

Pilot Escape

Study of the accelerations acting on the pilot in a tumble indicate that it may be very difficult for the pilot to climb out of the cockpit if it becomes necessary for him to leave the airplane during a tumble. Aid from an ejection-seat arrangement may be required. The results of brief tests of models 11 and 13 indicate that if the pilot can climb out of the cockpit and jump, he will not be struck by any parts of the airplane, in that the results showed that the model pilots cleared the models by a large margin in each of several attempts.

CONCLUSIONS

On the basis of the results of tumble tests of 14 dynamic models, the following conclusions are made.

1. Conventional airplanes will not tumble, whereas tailless and tail-first airplanes may tumble.
2. Increasing the static longitudinal stability tends towards the prevention of tumbling.
3. Tailless airplanes having low aspect ratio and a large pitching inertia parameter (I_Y/mb^2) are less likely to tumble than those having high aspect ratio and a small pitching inertia parameter.
4. Ailerons and rudder have little or no effect on tumbling.

5. Movement of the elevators to oppose the tumbling rotation will generally be effective in producing recovery from a tumble when the static longitudinal stability is marginal.

6. Two parachutes, one attached to each wing tip, will generally be effective in producing recovery from a tumble.

7. Accelerations in a tumble may be exceptionally dangerous.

Langley Aeronautical Laboratory
National Advisory Committee for Aeronautics
Langley Field, Va.

REFERENCES

1. Zimmerman, C. H.: Preliminary Tests in the N.A.C.A. Free-Spinning Wind Tunnel. NACA Rep. No. 557, 1936.
2. Armstrong, Harry G., and Heim, J. W.: The Effect of Acceleration on the Living Organism. ACTR No. 4362, Materiel Div., Army Air Corps, December 1, 1937.
3. Anon.: Human Tolerance to Negative g in Aircraft. MR No. MCREXD-695-69B, Air Materiel Command, U. S. Air Force, April 19, 1948.

TABLE I. - DIMENSIONAL CHARACTERISTICS OF MODELS TESTED

[Model values are presented in terms of corresponding airplane values]

Airplane	1	2	3	4	5	6	7
Model scale	$\frac{1}{18}$	$\frac{1}{20}$	$\frac{1}{20}$	$\frac{1}{16}$	$\frac{1}{16.95}$	$\frac{1}{17.8}$	$\frac{1}{30}$
Over-all length	27.04	30.17	29.75	15.00	29.58	29.46	50.70
Wing							
Span, ft	39.0	34.0	35.0	21.12	$\left. \begin{matrix} a_{40.57} \\ b_{41.02} \end{matrix} \right\}$	54.0	134.0
Area, sq ft	258	213.22	232	100	$\left. \begin{matrix} a_{208.3} \\ b_{213.2} \end{matrix} \right\}$	356	1800
Aspect ratio	5.9	5.43	5.28	4.41	$\left. \begin{matrix} a_{7.91} \\ b_{7.88} \end{matrix} \right\}$	8.2	10
Root chord, in.	98.64	98.6	100.0	85.71	$\left. \begin{matrix} a_{92.0} \\ b_{92.0} \end{matrix} \right\}$	116.6	279.6
Tip chord, in.	64.8	50.0	60.0	28.58	$\left. \begin{matrix} a_{23.70} \\ b_{33.54} \end{matrix} \right\}$	43.97	46.8
Taper ratio	0.66	0.51	0.60	0.33	$\left. \begin{matrix} a_{0.258} \\ b_{0.258} \end{matrix} \right\}$	0.376	0.167
\bar{c} , in.	83.3	80.64	83.16	61.91	$\left. \begin{matrix} a_{67.69} \\ b_{67.44} \end{matrix} \right\}$	85.82	190.8
Leading edge of \bar{c} rearward of leading edge of root chord, in.	3.08	5.41	42.85	41.36	$\left. \begin{matrix} a_{61.08} \\ b_{62.88} \end{matrix} \right\}$	-29.1 (forward)	82.8
Twist, deg	0	0	0	0	$\frac{1}{2}$ washout	1.5 washin	1.5 washout
Dihedral, deg	$\left. \begin{matrix} 5.5 \text{ at} \\ 30 \text{ percent} \\ \text{chord} \end{matrix} \right\}$	$\left. \begin{matrix} 4.0 \text{ at} \\ 30 \text{ percent} \\ \text{chord} \end{matrix} \right\}$	4.4	-4.0	$\left. \begin{matrix} 4.5 \text{ at} \\ 25 \text{ percent} \\ \text{chord} \end{matrix} \right\}$	$\left. \begin{matrix} 2 \text{ at} \\ 25 \text{ percent} \\ \text{chord} \end{matrix} \right\}$	4
Sweep at quarter chord, deg	0.41 back	0.75 back	0.8 back	34.0 back	28.5 back	15 forward	11.2 back
Section root	$\left. \begin{matrix} \text{CYH (expanded} \\ \text{to 18 percent} \\ \text{and modified)} \end{matrix} \right\}$	-----	$\left. \begin{matrix} \text{NACA} \\ 0015 \end{matrix} \right\}$	$\left. \begin{matrix} \text{NACA} \\ 65-010 \end{matrix} \right\}$	$\left. \begin{matrix} \text{C-W} \\ 6500-0015 \end{matrix} \right\}$	$\left. \begin{matrix} \text{NACA} \\ 23018 \end{matrix} \right\}$	$\left. \begin{matrix} \text{NACA-103 with} \\ 15^\circ \text{ reflex} \\ \text{of } 0.206 \end{matrix} \right\}$
Horizontal tail							
Span, ft	14.83	13.0	11.0	$\left. \begin{matrix} \text{Upper vee, 5.17} \\ \text{Lower vee, 4.71} \end{matrix} \right\}$	$\left. \begin{matrix} a_{8.92} \\ b_{11.31} \end{matrix} \right\}$	None	None
Area, sq ft	61.12	41.20	30.48	$\left. \begin{matrix} \text{Upper vee, 20.40} \\ \text{Lower vee, 11.67} \end{matrix} \right\}$	$\left. \begin{matrix} a_{18.63} \\ b_{21.52} \end{matrix} \right\}$	None	None
Elevator							
Type	Normal	Normal	Normal	Rudvators	$\left. \begin{matrix} \text{Tail first} \\ \text{all movable} \end{matrix} \right\}$	$\left. \begin{matrix} \text{On inboard} \\ \text{trailing edge} \\ \text{of wing} \end{matrix} \right\}$	$\left. \begin{matrix} \text{On inboard} \\ \text{trailing edge} \\ \text{of wing} \end{matrix} \right\}$
Total area, sq ft	27.07	17.30	12.02	4.86	$\left. \begin{matrix} a_{18.63} \\ b_{21.52} \end{matrix} \right\}$	36.40	156
Distance from center of gravity to hinge line, ft	17.15	16.83	16.47	$\left. \begin{matrix} \text{To quarter chord;} \\ 4.97 \text{ upper vee} \\ 5.74 \text{ lower vee} \end{matrix} \right\}$	15.95	5.42	10.4
Vertical tail							
Area, sq ft	25.77	19.01	14.36	$\left. \begin{matrix} \text{Vertical fins 8.32} \\ \text{center vertical} \\ \text{tail 7.55} \end{matrix} \right\}$	27.8	43.5	180
Rudder							
Type	Normal	Normal	Normal	Rudvators	$\left. \begin{matrix} \text{Dual wing-} \\ \text{tip rudders} \end{matrix} \right\}$	Normal	$\left. \begin{matrix} \text{Dual wing-} \\ \text{tip rudders} \end{matrix} \right\}$
Area, sq ft	13.53	11.07	8.03	See	13.01	19.4	90
Distance from center of gravity to hinge line, ft	17.08	17.25	16.77	Elevator	7.97	12.31	12.83
Lateral control							
Type	Ailerons	Ailerons	Ailerons	Ailerons	Ailerons	Ailerons	Ailerons
Span, percent b/2	36.62	39.0	40.5	40.3	39.11	52.85	50.3
Area rearward of hinge line, sq ft	21.62	12.76	12.32	2.8	15.2	36.4	110
Control deflections							
^c δ_r , deg	$\left. \begin{matrix} 30R \\ 30L \end{matrix} \right\}$	$\left. \begin{matrix} 30R \\ 30L \end{matrix} \right\}$	$\left. \begin{matrix} 30R \\ 30L \end{matrix} \right\}$	$\left. \begin{matrix} 15L \\ 15R \end{matrix} \right\}$	$\left. \begin{matrix} \text{Right: } 40R, 11L \\ \text{Left: } 11R, 40L \end{matrix} \right\}$	$\left. \begin{matrix} 25R \\ 25L \end{matrix} \right\}$	$\left. \begin{matrix} 50R \\ 50L \end{matrix} \right\}$
^d δ_e , deg	$\left. \begin{matrix} 30U \\ 20D \end{matrix} \right\}$	$\left. \begin{matrix} 30U \\ 15D \end{matrix} \right\}$	$\left. \begin{matrix} 30U \\ 15D \end{matrix} \right\}$	$\left. \begin{matrix} 30U \\ 15D \end{matrix} \right\}$	$\left. \begin{matrix} 60U \\ 60D \end{matrix} \right\}$	$\left. \begin{matrix} 30U \\ 20D \end{matrix} \right\}$	$\left. \begin{matrix} 40U \\ 10D \end{matrix} \right\}$
^d δ_a , deg	$\left. \begin{matrix} 30U \\ 15D \end{matrix} \right\}$	$\left. \begin{matrix} 25U \\ 10D \end{matrix} \right\}$	$\left. \begin{matrix} 20U \\ 10D \end{matrix} \right\}$	$\left. \begin{matrix} 20U \\ 20D \end{matrix} \right\}$	$\left. \begin{matrix} 28U \\ 9D \end{matrix} \right\}$	$\left. \begin{matrix} 20U \\ 15D \end{matrix} \right\}$	$\left. \begin{matrix} 15U \\ 15D \end{matrix} \right\}$

^aOriginal.
^bRevised.
^cL, left; R, right.
^dU, up; D, down.

TABLE I.- DIMENSIONAL CHARACTERISTICS OF MODELS TESTED - Concluded

Airplane	8	9	10	11	12	13	14
Model scale	$\frac{1}{16}$	$\frac{1}{20}$	$\frac{1}{57.33}$	$\frac{1}{16}$	$\frac{1}{60}$	$\frac{1}{17.55}$	$\frac{1}{20}$
Over-all length	28.13	17.78	50.9	14.25	54.0	36.44	41.37
Wing							
Span, ft	23.3	60.0	172.0	39.0	290.0	38.67	29.42
Area, sq ft	427.0	490	4020	293.31	7920	496	375
Aspect ratio	1.27	7.36	7.36	5.19	10.6	3.01	2.31
Root chord, in.	280.0	157.0	450.0	141.6	480.0	192.0	305.8
Tip chord, in.	-----	39.0	112	35.84	96	116.0	0
Taper ratio	-----	0.248	0.248	0.253	0.20	0.60	0
\bar{c} , in.	238	109.8	315	102.3	375.6	157.0	203.9
Leading edge of \bar{c} rearward of leading edge of root chord, in.	10.02	69.7	200	49.3	20.88	83.56	101.9
Twist, deg	0	4 washout 2 at 25 percent chord	4 washout 2 at 25 percent chord	1 at 25 percent chord	0	0	0
Dihedral, deg	0				0	0	0
Sweep at quarter chord, deg	0	21.9 back	21.9 back	24.9 back	0.6 forward	35 back CVA 4-(00) (12)-(1.1) -(1.0)	37.6 back
Section root	{ NACA 0016	{ NACA 6513-019	{ NACA 6513-019	{ NACA 6212-018	{ NACA 6314-020		{ NACA 65-006.5
Horizontal tail							
Span, ft	18.74	None	None	None	None	None	None
Area, sq ft	48.0	-----do-----	-----do-----	-----do-----	-----do-----	-----do-----	-----do-----
Elevator							
Type	Elevons	Elevons	Elevons	Elevons	{ On inboard trailing edge of wing	Elevons	Elevons
Total area, sq ft	48.0	31.85	{ 27.3 (rearward of hinge line)	32.61	24.0	54.4	33.31
Distance from center of gravity to hinge line, ft	11.45	{ 4.9 (inboard tip)	16.85	5.02	27.2	12.76	10.53
Vertical tail							
Area, sq ft	28.42	None	None	37.2	792	122.4	67.0
Rudder							
Type	Dual rudders	Split rudders	Split rudders	Split rudders	{ Dual wing-tip rudders	{ Dual rudders	{ Normal
Area, sq ft	13.52	14.63	120.0	21.68	306	32.0	13.8
Distance from center of gravity to hinge line, ft	{ 12.53 to top of hinge line	7.68	22.05	5.65	10.8	{ 15.15 to top of hinge line	{ 11.86
Lateral control							
Type	Elevons	Elevons	Elevons	Elevons	Ailerons	Elevons	Elevons
Span, percent b/2	See	See	See	See	58.6	See	See
Area rearward of hinge line, sq ft	Elevator	Elevator	Elevator	Elevator	638	Elevator	Elevator
Control deflections							
δ_r , deg	{ 25R 25L	{ 60U 60D	{ 60U 60D	{ 45U 45D	{ 30R 30L	{ 25R 25L	{ 30R 30L
δ_e , deg	{ 45U	{ 24U	{ 20U	{ 10.5U 10.5D	{ 10D	{ 30U	{ 20U
δ_a , deg	{ 15D	{ 11D	{ 10D	{ 21U 7D	{ 30U	{ 20D	{ 20D
δ_a , deg	{ 10U	{ 17U	{ 15U	{ 10.5U 10.5D	{ 10U	{ 15U	{ 15U
δ_a , deg	{ 10D	{ 13D	{ 15D	{ 14U 14D	{ 30D	{ 15D	{ 15D

^aOriginal.
^bRevised.
^cL, left; R, right.
^dU, up; D, down.

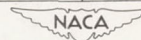

TABLE II.- MASS CHARACTERISTICS OF MODELS TESTED
 [Model values are presented in terms of full-scale values]

Model	Condition	Weight (lb)	Center-of-gravity location		Airplane relative density (μ)		Moments of inertia (slug-feet ²)			Pitching inertia parameter $\left(\frac{I_Y}{mb^2}\right)$
			x/\bar{c}	z/\bar{c}	Sea level	Altitude (ft)	I_X	I_Y	I_Z	
1	Normal	5,938	0.272	-0.045	7.67	6,000 9.19	3,223	5,931	8,752	0.021
2	Normal	7,406	.248	.100	13.3	6,000 15.99	5,201	6,077	10,704	.023
3	Normal	6,212	.290	.135	10.0	8,000 12.72	2,750	4,560	6,890	.019
4	Normal	4,552	.216	-.013	28.2	15,000 44.9	740	1,199	1,509	.019
5	Normal	7,698	.117	-.015	11.89	10,000 16.11	4,257	11,024	14,523	.028
6	Normal	3,846	.18	-.052	2.61	15,000 4.13	5,084	4,369	9,365	.013
	Normal; landing gear jettisoned	3,507	.16	-.035	2.38	3.79	4,789	4,275	9,096	.013
	Center of gravity 5 percent \bar{c} forward, normal	3,846	.13	-.052	2.61	4.13	5,084	4,864	9,860	.014
	Center of gravity 5 percent \bar{c} rearward, normal	3,846	.23	-.052	2.61	4.13	5,084	3,844	8,840	.011
	Fully loaded	7,886	.18	-.010	5.35	8.51	5,664	4,738	10,204	.007
7	Normal	60,600	.21	0	3.28	-----	1,156,577	232,708	1,392,379	.007
8	Normal	16,858	.263	.005	22.05	15,000 35.08	18,296	15,367	33,703	.054
9	Normal	6,526	.29	-.04	2.91	15,000 4.62	19,138	2,274	21,298	.003
	Center of gravity 5 percent \bar{c} forward, normal	6,694	.24	-.04	2.98	4.73	19,132	2,679	21,709	.004
10	Normal	155,000	.275	-.014	2.93	20,000 5.50	3,380,000	433,500	3,769,000 ²	.003
	Center of gravity 7.5 percent \bar{c} forward, normal	155,000	.200	-.014	2.93	5.50	3,380,000	433,500	3,769,000	.003
11	Normal	4,642	.251	.049	5.29	15,000 8.42	6,074	1,030	7,102	.005
	Intermediate loading	9,000	.268	.011	10.29	16.36	9,590	1,520	11,120	.004
	Maximum gross weight	13,291	.268	.011	15.18	24.14	19,151	1,925	20,902	.003
	Center of gravity 13.2 percent \bar{c} rearward, normal	4,642	.383	.049	5.29	8.42	6,074	1,030	7,102	.005
12	Normal	317,000	.20	0	1.8	20,000 3.39	36,513,234	10,018,370	36,513,234	.012
		317,000	.26		1.0					
		317,000	.275		1.0					
		317,000	.300		1.0					
13	Normal	14,517	.167	-.004	9.89	15,000 15.72	13,250	22,943	35,021	.034
	Center of gravity 7.71 percent \bar{c} rearward, normal	14,484	.24	-.003	9.87	15.68	13,250	23,810	35,887	.035
	Center of gravity 6.31 percent \bar{c} rearward, normal	14,484	.226	-.003	9.86	15.68	13,437	25,412	37,640	.038
14	Normal	11,648	.240	.014	13.80	21.93	3,989	27,619	29,557	.088

TABLE III.- INDEX TO TABLE NUMBERS IN WHICH THE RESULTS ARE PRESENTED FOR EACH MODEL TESTED

Model	Tumbling characteristics	Tumble-recovery parachute results	Pilot-escape results	Accelerations in tumbles
1	IV			
2	V			
3	VI			
4	VII			
5	VIII			
6	IX			
7	X			
8	XI			
9	XII	XIII		
10	XIV			
11	XV	XVI	XVII	XVIII
12	XIX			
13	XX	XXI		XXII
14	XXIII			

TABLE IV.- TUMBLING CHARACTERISTICS OF MODEL 1

[Normal loading; clean condition, ailerons neutral]

Method of launching model	Tunnel airspeed, full scale (fps)	Rudder	Behavior of model (a)			
			Longitudinal stick position			
			Full back	Neutral	Full forward	Free
Positive pitching rotation	137	Right		D	D	
Do-----	167	--do--	D			
Negative pitching rotation	137	Neutral	D			
Do-----	137	Right	D			D
Do-----	131	--do--		D	D	

^aKey

D No tumble; dived with no oscillation in pitch.

TABLE V.- TUMBLING CHARACTERISTICS OF MODEL 2

[Normal loading; clean condition; ailerons neutral]

Method of launching model	Tunnel airspeed, full scale (fps)	Rudder	Behavior of model (a)			
			Longitudinal stick position			
			Full back	Neutral	Full forward	Free
Positive pitching rotation	176	Right	D	D	D	
Negative pitching rotation	176	Neutral	D			
Do-----	176	Right	D	D	D	D

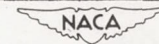

^aKey

D No tumble; dived with no oscillation in pitch.

TABLE VI.- TUMBLING CHARACTERISTICS OF MODEL 3

[Normal loading; clean condition; ailerons neutral]

Method of launching model	Tunnel airspeed, full scale (fps)	Rudder	Behavior of model (a)			
			Longitudinal stick position			
			Full back	Neutral	Full forward	Free
Positive pitching rotation	176	Right	D	D	D	
Negative pitching rotation	176	Neutral	D			
Do----	170	Right	D			
Do----	176	----do--		D	D	D

^aKey

D No tumble; dived with no oscillation in pitch.



TABLE VII.- TUMBLING CHARACTERISTICS OF MODEL 4

[Normal loading; clean condition; rudder neutral; flaps and landing hook retracted; tunnel airspeed for all tests was 161 feet per second, full scale]

Method of launching model	Lateral stick position	Behavior of model (a)		
		Longitudinal stick position		
		Full back	Neutral	Full forward
Positive pitching rotation	Neutral	C	C	C
Do----	Right	C	C	C
Do----	Left	C	C	C
Negative pitching rotation	Neutral	C	C	C
Do----	Right	C	C	C
Do----	Left	C	C	C

^aKey

C No tumble; dived with rapidly damped oscillation in pitch.

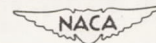

TABLE VIII.- TUMBLING CHARACTERISTICS OF MODEL 5

[Normal loading; ailerons neutral; rudders neutral]

Model configuration	Method of launching model	Tunnel airspeed, full scale (fps)	Behavior of model (a)					
			Longitudinal stick position					
			Full forward or 60° up	1/2 forward or 30° up	0	17° down	1/2 back or 30° down	Full back or 60° down
Small elevator, small wing tips	Positive pitching rotation	193	B			A		
Do-----	---do---	163			A			
Do-----	Negative pitching rotation	163	B		B			A
Do-----	---do---	193				B		
Do-----	Simulated whip stall	193	B					
Do-----	---do---	104			B			
Do-----	---do---	134				C		
Small elevator, large wing tips	Positive pitching rotation	163	C		A	A	B	B
Do-----	Negative pitching rotation	163	B	A, C	A			A
Do-----	Simulated whip stall	122	C					
Large elevator, large wing tips	Positive pitching rotation	163	C		A			A
Do-----	Negative pitching rotation	163	A		A			B
Do-----	Simulated whip stall	122	C		C			C
Large elevator, small wing tips	Positive pitching rotation	163	A		A			
Do-----	Negative pitching rotation	163	A		A			A
Do-----	Simulated whip stall	174			C			C
No elevator	Positive pitching rotation	163			A			
Do-----	Negative pitching rotation	163			A			

Key

- A Tumbled.
 B No tumble; dived with slightly damped oscillation in pitch.
 C No tumble; dived with rapidly damped oscillation in pitch.



TABLE IX.- TUMBLING CHARACTERISTICS OF MODEL 6

Change from original clean configuration	Loading	Method of launching model	Tunnel airspeed, full scale (fps)	Rate of descent, full scale (fps)	Rudder	Lateral stick position	Behavior of model (a)				
							Longitudinal stick position				
							Full back	Neutral	1/3 forward 10 down	2/3 forward 20 down	Full forward 30 down
Landing gear on; spoilers neutral	Normal	Negative pitching rotation	63	-----	Neutral	Neutral	C				
Do-----	-----do-----	-----do-----	63	96	--do--	-----do--		A			
Do-----	-----do-----	-----do-----	63	87	--do--	-----do--			A		
Do-----	-----do-----	-----do-----	63	-----	25 left	-----do--	C	A	A		
Do-----	-----do-----	-----do-----	63	-----	Neutral	Left	D	A	A		
Do-----	-----do-----	Positive pitching rotation	63	-----	--do--	Neutral	A		C		
Do-----	-----do-----	-----do-----	63	97	--do--	-----do--		A			
Do-----	-----do-----	-----do-----	63	-----	25 left	-----do--	A	A	C		
Do-----	-----do-----	-----do-----	63	-----	Neutral	Left	A	A	C		
Landing gear on; spoilers extended	-----do-----	Negative pitching rotation	63	-----	--do--	Neutral	D	A	A		
Do-----	-----do-----	-----do-----	63	95	--do--	-----do--				A	
Do-----	-----do-----	Positive pitching rotation	63	95	--do--	-----do--	A				
Do-----	-----do-----	-----do-----	63	-----	--do--	-----do--		C	C	C	
Spoilers neutral; landing gear jettisoned	Center of gravity 2 percent \bar{c} forward	Negative pitching rotation	63	-----	--do--	-----do--	D	A	A		
Do-----	-----do-----	-----do-----	63	88	--do--	-----do--				A	
Do-----	-----do-----	-----do-----	63	91	--do--	-----do--	A				
Do-----	-----do-----	-----do-----	63	-----	--do--	-----do--		B	D	D	
Landing gear on; spoilers neutral	Center of gravity 5 percent \bar{c} forward	Negative pitching rotation	63	-----	--do--	-----do--	C	C	A	A	
Do-----	-----do-----	Positive pitching rotation	63	-----	--do--	-----do--	A	C	C	C	
Do-----	Center of gravity 5 percent \bar{c} rearward	Negative pitching rotation	63	-----	--do--	-----do--	C	A	A	A	
Do-----	-----do-----	Positive pitching rotation	63	-----	--do--	-----do--	A	A	A	C	
Spoilers neutral	Fully loaded	Negative pitching rotation	102.1	-----	--do--	-----do--	C	A		A	
Do-----	-----do-----	Positive pitching rotation	102.1	-----	--do--	-----do--	A	C		D	
Do-----	Minimum flying weight	Released in a nose-up attitude simulating a whip stall	38	100	--do--	-----do--	B				
Do-----	-----do-----	-----do-----	38	102	--do--	-----do--		B			
Do-----	-----do-----	-----do-----	38	-----	--do--	-----do--			D		
Do-----	-----do-----	-----do-----	38	-----	25 left	-----do--	B	B	B		
Do-----	-----do-----	-----do-----	49	-----	Neutral	Left	B	B	B		

^aKey
 A Tumbled.
 B No tumble; dived with slightly damped oscillation in pitch.
 C No tumble; dived with rapidly damped oscillation in pitch.
 D No tumble; dived with no oscillation in pitch.



TABLE X.- TUMBLING CHARACTERISTICS OF MODEL 7

[Flaps up; rudder neutral]

Loading	Method of launching model	Aileron deflection	Behavior of model (a)	
			Elevator deflection	
			10° up	0°
Normal	Positive pitching rotation	Both 10° up	A	
Do-----	Nose-up attitude	----do----	D	
Center of gravity 4 percent \bar{c} rearward, normal	-----do-----	0°		A
Do-----	-----do-----	Both 10° up	A	
Center of gravity 3 percent \bar{c} rearward, normal	-----do-----	----do----	D	
Center of gravity 2 percent \bar{c} rearward, normal	-----do-----	----do----	D	

^aKey

A Tumbled.

D No tumble; dived with no oscillation in pitch.

TABLE XI.- TUMBLING CHARACTERISTICS OF MODEL 8

[Normal loading; clean condition; rudder neutral; ailerons neutral]

Method of launching model	Tunnel airspeed, full scale (fps)	Behavior of model (a)		
		Longitudinal stick position		
		Full back	Neutral	Full forward
Released in a nose-up attitude simulating a whip stall without rotation	188	C	C	C
Positive pitching rotation	188	C		C
Negative pitching rotation	188	C		C

^aKey

C No tumble; dived with rapidly damped oscillations in pitch.

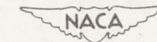

TABLE XII.- TUMBLING CHARACTERISTICS OF MODEL 9

Change from original clean configuration	Loading	Landing flap deflection (deg)	Pitch flap deflection (deg)	Landing gear	Method of launching model	Tunnel airspeed, full scale (fps)	Lateral stick position	Behavior of model (a)		
								Longitudinal stick position		
								Full back	Neutral	Full forward
None	Normal	0	0	Retracted	Positive pitching rotation	65	Full left	A		A
Do-----	-----do-----	0	0	---do---	---do---	65	Neutral	A, B	A	A
Do-----	-----do-----	0	0	---do---	---do---	65	Full right	A		
Do-----	-----do-----	0	0	---do---	Negative pitching rotation	65	Full left	A		A
Do-----	-----do-----	0	0	---do---	---do---	65	Neutral	A, B	A	A
Do-----	-----do-----	0	0	---do---	---do---	65	Full right	A, B		
Equivalent propeller fin area installed	-----do-----	0	0	---do---	Positive pitching rotation	65	Full left	A		A
Do-----	-----do-----	0	0	---do---	---do---	65	Neutral	A	A	A
Do-----	-----do-----	0	0	---do---	---do---	65	Full right	A		
Do-----	-----do-----	0	0	---do---	Negative pitching rotation	65	Full left	A		A
Do-----	-----do-----	0	0	---do---	---do---	65	Neutral	A	A	A
Do-----	-----do-----	0	0	---do---	---do---	65	Full right	A		
None	Center of gravity 5 percent \bar{c} forward for flight-test condition	0	0	---do---	Positive pitching rotation	65	Full left	A		A
Do-----	-----do-----	0	0	---do---	---do---	65	Neutral	A	A	A
Do-----	-----do-----	0	0	---do---	---do---	65	Full right	A		

Key

A Tumbled.

B No tumble; dived with slightly damped oscillation in pitch.



TABLE XII.- TUMBLING CHARACTERISTICS OF MODEL 9 - Continued

Change from original clean configuration	Loading	Landing flap deflection (deg)	Pitch flap deflection (deg)	Landing gear	Method of launching model	Tunnel airspeed, full scale (fps)	Lateral stick position	Behavior of model (a)		
								Longitudinal stick position		
								Full back	Neutral	Full forward
None	Center of gravity 5 percent \bar{c} forward for flight-test condition	0	0	Retracted	Negative pitching rotation	65	Full left	C		A, C
Do-----	-----do-----	0	0	---do---	---do---	65	Neutral	C	C	A, C
Do-----	-----do-----	0	0	---do---	---do---	65	Full right	C		
Auxiliary leading-edge 20-percent-span slats installed	Normal	0	0	---do---	Positive pitching rotation	65	Full left	A		A, C
Do-----	-----do-----	0	0	---do---	---do---	65	Neutral	A	A	A
Do-----	-----do-----	0	0	---do---	---do---	65	Full right	A		A
Do-----	-----do-----	0	0	---do---	Negative pitching rotation	65	Full left	A		A
Do-----	-----do-----	0	0	---do---	---do---	65	Neutral	C	A	A
Do-----	-----do-----	0	0	---do---	---do---	65	Full right	A		A
Auxiliary leading-edge 35-percent-span slats installed	-----do-----	0	0	---do---	Positive pitching rotation	65	Full left	A		C
Do-----	-----do-----	0	0	---do---	---do---	65	Neutral	A	A	A, C
Do-----	-----do-----	0	0	---do---	---do---	65	Full right	A		A
Do-----	-----do-----	0	0	---do---	Negative pitching rotation	65	Full left	C		A, C
Do-----	-----do-----	0	0	---do---	---do---	65	Neutral	C	A	A
Do-----	-----do-----	0	0	---do---	---do---	65	Full right	C		A, C

^aKey
 A Tumbled.
 C No tumble; dived with rapidly damped oscillation in pitch.



TABLE XII.- TUMBLING CHARACTERISTICS OF MODEL 9 - Continued

Change from original clean configuration	Loading	Landing flap deflection (deg)	Pitch flap deflection (deg)	Landing gear	Method of launching model	Tunnel airspeed, full scale (fps)	Lateral stick position	Behavior of model (a)		
								Longitudinal stick position		
								Full back	Neutral	Full forward
Split-type rudders installed and deflected $\pm 60^\circ$ on both wing tips	Normal	0	0	Retracted	Positive pitching rotation	65	Full left	A		A
Do-----	----do-----	0	0	---do----	---do----	65	Neutral	A	A	A
Do-----	----do-----	0	0	---do----	---do----	65	Full right	A		
Do-----	----do-----	0	0	---do----	Negative pitching rotation	65	Full left	A		A
Do-----	----do-----	0	0	---do----	---do----	65	Neutral	A	A	A
Do-----	----do-----	0	0	---do----	---do----	65	Full right	A		
Landing	----do-----	50 down	26 up	Extended	Positive pitching rotation	65	Full left	A		
Do-----	----do-----	50 down	26 up	---do----	---do----	65	Neutral	A	A	A
Do-----	----do-----	50 down	26 up	---do----	---do----	65	Full right	A		A
Do-----	----do-----	50 down	26 up	---do----	Negative pitching rotation	65	Full left	A		
Do-----	----do-----	50 down	26 up	---do----	---do----	65	Neutral	A	A	A
Do-----	----do-----	50 down	26 up	---do----	---do----	65	Full right	A		A
Horizontal area = 10 percent wing area installed on a boom rearward of the model	----do-----	0	0	Retracted	Positive pitching rotation	65	Full left	C		C
Do-----	----do-----	0	0	---do----	---do----	65	Neutral	C	C	C
Do-----	----do-----	0	0	---do----	---do----	65	Full right	C		C

^aKey

A Tumbled.

C No tumble; dived with rapidly damped oscillation in pitch.



TABLE XII.- TUMBLING CHARACTERISTICS OF MODEL 9 - Continued

Change from original clean configuration	Loading	Landing flap deflection (deg)	Pitch flap deflection (deg)	Landing gear	Method of launching model	Tunnel airspeed, full scale (fps)	Lateral stick position	Behavior of model (a)		
								Longitudinal stick position		
								Full back	Neutral	Full forward
Horizontal area = 10 percent wing area installed on a boom rearward of the model	Normal	0	0	Retracted	Negative pitching rotation	65	Full left	C		C
Do-----	---do-----	0	0	---do----	---do---	65	Neutral	C	C	C
Do-----	---do-----	0	0	---do----	---do---	65	Full right	C		C
Horizontal area = 5 percent wing area installed on a boom rearward of the model	---	0	0	---	Positive pitching rotation	65	Full left	C		C
Do-----	---do-----	0	0	---do----	---do---	65	Neutral	C	C	C
Do-----	---do-----	0	0	---do----	---do---	65	Full right	C		
Do-----	---do-----	0	0	---do----	Negative pitching rotation	65	Full left	C		C
Do-----	---do-----	0	0	---do----	---do---	65	Neutral	C	C	C
Do-----	---do-----	0	0	---do----	---do---	65	Full right	C		
Horizontal area = 2 percent wing area installed on a boom rearward of the model	---	0	0	---	Positive pitching rotation	65	Full left	A		A
Do-----	---do-----	0	0	---do----	---do---	65	Neutral	A	A, C	A
Do-----	---do-----	0	0	---do----	---do---	65	Full right	A		
Do-----	---do-----	0	0	---do----	Negative pitching rotation	65	Full left	A		A
Do-----	---do-----	0	0	---do----	---do---	65	Neutral	A, C	A	A
Do-----	---do-----	0	0	---do----	---do---	65	Full right	A		

^aKey

A Tumbled.

C No tumble; dived with rapidly damped oscillation in pitch.

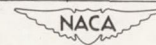

TABLE XII.-- TUMBLING CHARACTERISTICS OF MODEL 9 - Continued

Change from original clean configuration	Loading	Landing flap deflection (deg)	Pitch flap deflection (deg)	Landing gear	Method of launching model	Tunnel airspeed, full scale (fps)	Lateral stick position	Behavior of model (a)		
								Longitudinal stick position		
								Full back	Neutral	Full forward
None	Normal	0	0	Retracted	Released without rotation from a nose-up vertical attitude	75	Full left	A, B		A, B
Do-----	-----do-----	0	0	---do---	---do---	75	Neutral	A, B	A, B	A, B
Do-----	-----do-----	0	0	---do---	---do---	75	Full right	A, B		
Equivalent propeller fin area installed	-----do-----	0	0	---do---	---do---	75	Full left			B
Do-----	-----do-----	0	0	---do---	---do---	75	Neutral	A, B	A, B	A, B
Do-----	-----do-----	0	0	---do---	---do---	75	Full right	A, B		
None	Center of gravity 5 percent \bar{c} forward	0	0	---do---	---do---	75	Full left	C		C
Do-----	-----do-----	0	0	---do---	---do---	75	Neutral	C	C	C
Do-----	-----do-----	0	0	---do---	---do---	75	Full right	C		C
20-percent-span auxiliary leading-edge slats installed	Normal	0	0	---do---	---do---	75	Full left	C		C
Do-----	-----do-----	0	0	---do---	---do---	75	Neutral	A, C	A, C	C
Do-----	-----do-----	0	0	---do---	---do---	75	Full right	C		C
35-percent-span auxiliary leading-edge slats installed	-----do-----	0	0	---do---	---do---	75	Full left	C		C
Do-----	-----do-----	0	0	---do---	---do---	75	Neutral	A, C	C	C
Do-----	-----do-----	0	0	---do---	---do---	75	Full right	C		C

^aKey

- A Tumbled.
 B No tumble; dived with slightly damped oscillation in pitch.
 C No tumble; dived with rapidly damped oscillation in pitch.

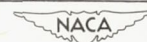

TABLE XII.- TUMBLING CHARACTERISTICS OF MODEL 9 - Continued

Change from original clean configuration	Loading	Landing flap deflection (deg)	Pitch flap deflection (deg)	Landing gear	Method of launching model	Tunnel airspeed, full scale (fps)	Lateral stick position	Behavior of model (a)		
								Longitudinal stick position		
								Full back	Neutral	Full forward
Split-type rudders installed and deflected 160° on both wing tips	Normal	0	0	Retracted	Released without rotation from a nose-up vertical attitude	75	Full left	B		B
Do-----	-----do-----	0	0	---do---	---do---	75	Neutral	B	A, B	B
Do-----	-----do-----	0	0	---do---	---do---	75	Full right	A, B	B	B
Landing	-----do-----	50 down	26 up	Extended	---do---	75	Full left	C		C
Do-----	-----do-----	50 down	26 up	---do---	---do---	75	Neutral	C	C	C
Do-----	-----do-----	50 down	26 up	---do---	---do---	75	Full right	C		C
Landing flaps deflected and landing gear extended	-----do-----	50 down	0	---do---	---do---	75	Neutral	C	C	C
Do-----	-----do-----	50 down	0	---do---	---do---	75	Full right	C		
Landing flaps deflected	-----do-----	50 down	0	Retracted	---do---	75	Full left	C		C
Do-----	-----do-----	50 down	0	---do---	---do---	75	Neutral	C	C	C
Do-----	-----do-----	50 down	0	---do---	---do---	75	Full right	C		
Landing gear extended	-----do-----	0	0	Extended	---do---	75	Neutral	A, B	A, B	A, B
Pitch flaps deflected	-----do-----	0	26 up	Retracted	---do---	75	Full left	A, B		B
Do-----	-----do-----	0	26 up	---do---	---do---	75	Neutral	A, B	A, B	A, B
Do-----	-----do-----	0	26 up	---do---	---do---	75	Full right	A, B		
Horizontal area = 10 percent wing area installed on a boom rearward of the model	-----do-----	0	26 up	---do---	---do---	75	Full left	C		

^aKey

- A Tumbled.
- B No tumble; dived with slightly damped oscillation in pitch.
- C No tumble; dived with rapidly damped oscillation in pitch.

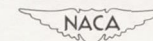

TABLE XII.- TUMBLING CHARACTERISTICS OF MODEL 9 - Continued

Change from original clean configuration	Loading	Landing flap deflection (deg)	Pitch flap deflection (deg)	Landing gear	Method of launching model	Tunnel airspeed, full scale (fps)	Lateral stick position	Behavior of model (a)		
								Longitudinal stick position		
								Full back	Neutral	Full forward
Horizontal area = 10 percent wing area installed on a boom rearward of the model	Normal	0	26 up	Retracted	Released without rotation from a nose-up vertical attitude	75	Neutral	C	C	C
Do-----	----do-----	0	26 up	---do----	---do---	75	Full right	C		
Horizontal area = 5 percent wing area installed on a boom rearward of the model	----do-----	0	26 up	---do----	---do---	75	Full left	C		C
Do-----	----do-----	0	26 up	---do----	---do---	75	Neutral	C	C	C
Do-----	----do-----	0	26 up	---do----	---do---	75	Full right	C		
Horizontal area = 2 percent wing area installed on a boom rearward of the model	----do-----	0	26 up	---do----	---do---	75	Full left	C		C
Do-----	----do-----	0	26 up	---do----	---do---	75	Neutral	C	C	C
Do-----	----do-----	0	26 up	---do----	---do---	75	Full right	C		
None	----do-----	0	26 up	---do----	Nose of model approximately 70° below horizontal when released	75	Full left	B		B

^aKey

B No tumble; dived with slightly damped oscillation in pitch.

C No tumble; dived with rapidly damped oscillation in pitch.

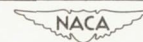

TABLE XII.- TUMBLING CHARACTERISTICS OF MODEL 9 - Concluded

Change from original clean configuration	Loading	Landing flap deflection (deg)	Pitch flap deflection (deg)	Landing gear	Method of launching model	Tunnel airspeed, full scale (fps)	Lateral stick position	Behavior of model (a)		
								Longitudinal stick position		
								Full back	Neutral	Full forward
None	Normal	0	26 up	Retracted	Nose of model approximately 70° below horizontal when released	75	Neutral	B	B	B
Do-----	----do----	0	26 up	---do---	----do----	75	Full right	B		
Do-----	----do----	0	26 up	---do---	Model horizontal when released	75	Full left	C		C
Do-----	----do----	0	26 up	---do---	----do----	75	Neutral	C	C	C
Do-----	----do----	0	26 up	---do---	----do----	75	Full right	C		
Do-----	----do----	0	26 up	---do---	Nose slightly above the horizontal	75	Full left	C		C
Do-----	----do----	0	26 up	---do---	----do----	75	Neutral	C	C	C
Do-----	----do----	0	26 up	---do---	----do----	75	Full right	C		

^aKey
 B No tumble; dived with slightly damped oscillation in pitch.
 C No tumble; dived with rapidly damped oscillation in pitch.

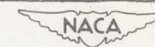

TABLE XIII.- EFFECTIVENESS OF PARACHUTES IN PRODUCING RECOVERY FROM ESTABLISHED TUMBLES
OF MODEL 9

[Clean configuration; normal loading; stick neutral; wheel neutral; pitch flaps neutral; landing flaps neutral; landing gear retracted; towline length as indicated; point of towline attachment as indicated; diameter of parachutes 7 feet, full scale; drag coefficient of parachutes, approximately 0.7; tunnel airspeed for all tests was approximately 85 feet per second, full scale; models launched with initial positive pitching rotation; recoveries from tumbles attempted by opening parachutes as indicated]

Towline attached to	Towline length, full scale (ft)	Recovery attempted by	Tumbles for recovery after parachutes opened	Behavior of model (a)
Fixed portion of wing between elevons and pitch flaps	2.5	Opening two parachutes, one attached to each wing	$>3, >3\frac{1}{2}$	^b A
Do-----	30.0	-----do-----	$>3, >3$	^b A
Rear portion of wing tip	10.0	-----do-----	$1\frac{1}{2}, 1\frac{1}{2}$	B
Do-----	30.0	-----do-----	1, 1	B
Do-----	10.0	Opening parachute attached to right wing tip	$1\frac{1}{2}, 2\frac{1}{2}$	B
Do-----	30.0	-----do-----	$>2, >3$	A

^aKey

A Tumbled.

B No tumble; dived with slightly damped oscillations in pitch.

^bTowline and parachutes wrapped around wing.



TABLE XIV.- TUMBLING CHARACTERISTICS OF MODEL 10

Change from original clean configuration	Loading	Method of launching model	Tunnel airspeed, full scale (fps)	Pitch flap deflection (deg)	Rudders	Lateral stick position	Behavior of model (a)		
							Longitudinal stick position		
							Full back	Neutral	Full forward
None	Normal	Released in a nose-up attitude simulating a whip stall	111	0	Neutral	Neutral	B	B	B
Do-----	-----do-----	-----do-----	111	0	---do---	Left	B	B	B
Do-----	-----do-----	-----do-----	111	0	---do---	Right	B	B	A
Do-----	-----do-----	-----do-----	172	0	---do---	Left			A
Do-----	-----do-----	Positive pitching rotation	172	0	---do---	Neutral	A	A	A
Do-----	-----do-----	-----do-----	172	0	---do---	Right	A	A	A
Do-----	-----do-----	-----do-----	172	0	---do---	Left	A	A	A
Do-----	-----do-----	Negative pitching rotation	172	0	---do---	---do---	A	A	A
Do-----	-----do-----	-----do-----	172	0	---do---	Neutral	A	A	A
Do-----	-----do-----	-----do-----	172	0	---do---	Right	A	A	A
Do-----	Center of gravity 7.5 percent \bar{c} forward	-----do-----	172	0	---do---	Neutral	B	B	B
Do-----	-----do-----	-----do-----	172	0	---do---	Left	B	B	B
Do-----	-----do-----	Positive pitching rotation	172	0	---do---	---do---	A	B	B
Do-----	-----do-----	-----do-----	172	0	---do---	Neutral	B	B	B
Do-----	Normal	-----do-----	172	0	Both open	---do---	A	A	A
Do-----	-----do-----	-----do-----	172	0	---do---	Right	A	A	A
Do-----	-----do-----	Negative pitching rotation	172	0	---do---	---do---	B	A	A
Do-----	-----do-----	-----do-----	172	0	---do---	Neutral	B	A	A
Do-----	-----do-----	-----do-----	172	0	Right open	---do---	A		
Do-----	-----do-----	-----do-----	172	0	---do---	Left	A		
Do-----	-----do-----	-----do-----	172	0	---do---	Right	A		
Do-----	-----do-----	Positive pitching rotation	172	0	---do---	---do---	A		
Do-----	-----do-----	-----do-----	172	0	---do---	Neutral	A		
Do-----	-----do-----	-----do-----	172	0	---do---	Left	A		
Do-----	-----do-----	-----do-----	172	30 up	Neutral	---do---	A	A	A
Do-----	-----do-----	-----do-----	172	30 up	Neutral	Neutral	A	A	A
Do-----	-----do-----	Negative pitching rotation	172	30 up	---do---	---do---	B	A	A
Do-----	-----do-----	-----do-----	172	30 up	---do---	Left	B	A	A
Do-----	-----do-----	-----do-----	172	15 down	---do---	---do---	A	A	A
Do-----	-----do-----	-----do-----	172	15 down	---do---	Neutral	A	A	A
Do-----	-----do-----	Positive pitching rotation	172	15 down	---do---	---do---	A	A	A
Do-----	-----do-----	-----do-----	172	15 down	---do---	Left	A	A	A
Landing flaps down 60°	-----do-----	-----do-----	172	0	---do---	Neutral	A	A	A, D
Do-----	-----do-----	Negative pitching rotation	172	0	---do---	---do---	A		A
Do-----	-----do-----	Positive pitching rotation	172	15 down	---do---	---do---	A	B, D	B, D
Do-----	-----do-----	-----do-----	172	15 down	Right open	---do---		A, D	B, D
Do-----	-----do-----	-----do-----	172	15 down	---do---	Right		A, D	
Do-----	-----do-----	-----do-----	172	15 down	---do---	Left		A, D	
Outboard spoilers open	-----do-----	-----do-----	172	0	Neutral	Neutral		A	A
Do-----	-----do-----	Negative pitching rotation	172	0	---do---	---do---	A	A	
Slots open	-----do-----	-----do-----	172	0	---do---	---do---	A		
Do-----	-----do-----	Positive pitching rotation	172	0	---do---	---do---			A
Slots and center spoilers open	-----do-----	-----do-----	172	0	---do---	---do---			A
Do-----	-----do-----	Negative pitching rotation	172	0	---do---	---do---	A, D		
Slots open	-----do-----	-----do-----	172	0	Left open	---do---	B		A

Key
 A Tumbled.
 B No tumble; dived with slightly damped oscillation in pitch.
 D No tumble; dived with no oscillation in pitch.

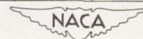

TABLE IV.- TUMBLING CHARACTERISTICS OF MODEL 11

Model condition				Loading	Method of launching model	Tunnel airspeed, full scale (fps)	Lateral stick position	Behavior of model (a)		
Auxiliary lift devices	Rudders	Landing gear	Elevon deflections					Longitudinal stick position		
								Full back	Neutral	Full forward
40-percent-semispan slats	Neutral	Retracted	Original	Normal	Positive pitching rotation	178	Neutral	C	C	C
Do----	---do---	---do---	---do---	-----do-----	Negative pitching rotation	178	---do--	C	C	C
Do----	---do---	---do---	Revised	-----do-----	-----do-----	178	---do--	C	C	C
25-percent-semispan slats	---	---	---	---	Positive pitching rotation	178	---do--	A	C	C
Do----	Full open as dive brakes	---	---	---	-----do-----	178	---do--	A	C	C
Do----	---	---	---	---	Negative pitching rotation	178	---do--	C	C	C
Do----	Neutral	Extended	---	---	Positive pitching rotation	178	---do--	A		A
25-percent-semispan auxiliary airfoil	---	Retracted	---	---	-----do-----	178	---do--	A	C	C
Do----	---	---	---	---	Negative pitching rotation	178	---do--	B, D	C	A
25-percent-semispan slats	---	---	---	Intermediate loading	-----do-----	208	---do--	C	A	A
Do----	---	---	---	---	Positive pitching rotation	208	---do--	A	A	A
Do----	---	---	---	Maximum gross weight	-----do-----	234	---do--	A	A	A
Do----	---	Extended	---	---	Negative pitching rotation	234	---do--	A, D	A	A
25-percent-semispan auxiliary airfoils	---	---	---	---	Positive pitching rotation	234	---do--	A	A	A
None	Neutral	Retracted	Original	Normal	Released from nose-up whip stall	178	---do--	C	C	C
25-percent-semispan slats	---	---	Revised	---	-----do-----	178	---do--	C	C	C
25-percent-semispan auxiliary airfoils	---	---	---	---	-----do-----	178	---do--	C	C	C
25-percent-semispan slats	---	---	---	Center of gravity 13.1 percent \bar{c} rearward	-----do-----	178	---do--	B	A	A
Do----	---	---	---	---	Released from nose-down whip stall	178	---do--	A	A	A

Key

- A Tumbled.
 B No tumble; dived with slightly damped oscillation in pitch.
 C No tumble; dived with rapidly damped oscillation in pitch.
 D No tumble; dived with no oscillation in pitch.



TABLE XVI.- EFFECTIVENESS OF WING-TIP PARACHUTES IN PRODUCING RECOVERY FROM TUMBLES OF MODEL 11

[Loading as indicated; landing gear retracted; 25-percent-semispan slats extended; cockpit closed; rudder neutral for all tests]

Loading	Method of launching model	Number of parachutes released	Flat diameter of parachute, full scale (ft)	Towline length, full scale (ft)	Tumbles for recovery after parachute opened	Lateral stick position	Behavior of model (a)		
							Longitudinal stick position		
							Full back	Neutral	Full forward
Intermediate	Positive pitching rotation	One from wing tip	8	19.5	--	Neutral	A	A	
Do-----	-----do-----	-----do-----	8	19.5	--	Right		A	
Do-----	-----do-----	One from each wing tip	6.67	9.75	--	Neutral	A		
Do-----	-----do-----	-----do-----	8.0	9.75	--	---do--	A		
Do-----	-----do-----	-----do-----	7.2	9.75	--	---do--	A		
Do-----	-----do-----	-----do-----	8.0	19.5	--	---do--	A		
Do-----	-----do-----	-----do-----	7.2	19.5	--	---do--	A		
Do-----	Negative pitching rotation	-----do-----	6.67	9.75	$5\frac{1}{4}$	---do--			D
Maximum gross weight	Positive pitching rotation	One from wing tip	6.67	19.5	--	---do--			A
Do-----	-----do-----	-----do-----	10.9	19.5	6	---do--			D
Do-----	-----do-----	One from each wing tip	8	19.5	$1\frac{3}{4}$	---do--			D
Do-----	-----do-----	-----do-----	10.9	19.5	$1\frac{3}{4}$	---do--			D

^aKey

A Tumbled.

D No tumble; dived with no oscillation in pitch.

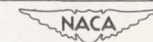

TABLE XVII.- ESCAPE OF DUMMY PILOT DURING TUMBLE OF MODEL 11

Loading condition	Model condition	Dummy released from	Behavior of dummy
Maximum gross weight center-of-gravity 26.8 percent \bar{c}	25-percent- semispan slats; normal drag rudders; vertical fins	Top hatch	Thrown forward over the nose of the model cleared all surfaces
Do-----	-----do-----	Bottom hatch	Do.



TABLE XVIII.- RATE OF TUMBLE AND ACCELERATIONS ENCOUNTERED IN TUMBLES OF MODEL 11

Model condition	Method of launching model	Ω (full scale) (radians/sec)	r (full scale) (ft)	Resultant acceleration acting on pilot's head (g units)
Center of gravity 13.2 percent \bar{c} rearward normal. Minimum flying weight	Whip stall	7.1	4.9	7.7
Intermediate loading; 25-percent-semispan slats	Positive pitching rotation	5.9	4.9	5.3
Maximum gross weight; 25-percent-semispan slats	----do----	7.0	4.9	7.5
Maximum gross weight; auxiliary airfoils installed	----do----	8.2	4.9	10.0

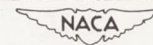

TABLE XIX.- TUMBLING CHARACTERISTICS OF MODEL 12

[Normal loading; tip tails installed;
rudder neutral]

Change from original clean condition	Loading	Method of launching model	Tunnel airspeed, full-scale (fps)	Aileron deflection (deg)	Behavior of model (a)		
					Elevator deflection		
					30° up	0°	30° down
13-percent root chord extension on elevators	Center of gravity 6 percent \bar{c} rearward	Positive pitching rotation	95	0		D	D
Do-----	-----do-----	-----do-----	145	0	A		
Do-----	-----do-----	-----do-----	95	0	B		
Do-----	-----do-----	-----do-----	95	20 both down	A		
Do-----	-----do-----	Negative pitching rotation	95	0	D		D
Do-----	-----do-----	-----do-----	145	0	D		
Do-----	-----do-----	Released with nose up	145	0	B, C	C	C
Do-----	-----do-----	-----do-----	145	20 both down	C		
Do-----	Center of gravity 7.5 percent \bar{c} rearward	-----do-----	95	0	C		
Do-----	-----do-----	Positive pitching rotation	95	0	A		
Do-----	Center-of-gravity 10 percent \bar{c} rearward	Released with nose up	145	0	B	B	

^aKey

- A Tumbled.
- B No tumble; dived with slightly damped oscillation in pitch.
- C No tumble; dived with rapidly damped oscillation in pitch.
- D No tumble; dived with no oscillation in pitch.

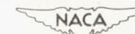

TABLE XX.- TUMBLING CHARACTERISTICS OF MODEL 13
 [Center-of-gravity location as indicated; landing gear retracted; ailerons neutral; rudders neutral]

Loading	Configuration	Tunnel airspeed, full scale (fps)	Method of launching model	Behavior of model (a)		
				Longitudinal stick position		
				Full back	Neutral	Full forward
Normal	Clean	168	Positive pitching rotation	D	C	D
Do-----	-----do-----	168	Negative pitching rotation	D		
Center of gravity 7.71 percent \bar{c} rearward of normal	-----do-----	168	Positive pitching rotation		B	C
Do-----	-----do-----	168	Negative pitching rotation	C	C	(b)
Do-----	Slats open	168	Positive pitching rotation	A	C	C
Do-----	-----do-----	168	Negative pitching rotation	C	C	D
Do-----	Speed brakes open	168	Positive pitching rotation			C
Do-----	-----do-----	168	Negative pitching rotation	C		
Do-----	Slats open	168	Released from nose-up simulated whip stall	C		
Do-----	-----do-----	168	Released from nose-horizontal simulated recovery from whip stall	D		
Do-----	Clean	168	Released from nose-up simulated whip stall	C		
Do-----	-----do-----	168	Released from nose-horizontal simulated recovery from whip stall		B	
Center of gravity 6.31 percent \bar{c} rearward of normal	Slats open	168	Positive pitching rotation	B, C	C	
Do-----	Clean	168	-----do-----	C	C	

^aKey
 A Tumbled.
 B No tumble; dived with slightly damped oscillation in pitch.
 C No tumble; dived with rapidly damped oscillation in pitch.
 D No tumble; dived with no oscillation in pitch.
^bAfter recovery from tumble, model went into a spin.

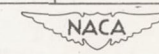

TABLE XXI.- EFFECTIVENESS OF PARACHUTES IN PRODUCING RECOVERY FROM ESTABLISHED TUMBLES

OF MODEL 13

[Normal loading; center of gravity located 24 percent mean aerodynamic chord; elevator full-up; ailerons neutral; rudders neutral; slats extended; landing gear retracted; towline attached to wing tip; 75 percent of wing-tip chord; tunnel airspeed for all tests was approximately 168 feet per second, full scale; model launched with positive initial pitching rotation; recovery attempted by opening parachutes as indicated]

Drag coefficient	Diameter, full scale (ft)	Towline length, full scale (ft)	Recovery attempted by	Tumbles for recovery after parachutes opened	Behavior of model (a)
0.69	8.3	25	Opening two parachutes, one attached to each wing tip	$\frac{1}{4}$, $\frac{1}{4}$	D
.67	4.4	13.6	-----do-----	$\frac{1}{2}$, $\frac{3}{4}$, $1\frac{1}{2}$, $1\frac{3}{4}$,	(b)
.69	8.3	25	Opening parachute attached to right wing tip	$\frac{1}{2}$, $\frac{1}{2}$	(c)
.67	4.4	13.6	-----do-----	$\frac{1}{4}$, 1	(c)

^aKey

D No tumble; dived with no oscillation in pitch.

^bBoth parachutes collapsed in wing wake and reopened and went into spin.^cAfter recovery from tumble, model went into a spin.

TABLE XXII.- ACCELERATIONS IN A TUMBLE OF MODEL 13

Center of gravity located at 24 percent of the mean aerodynamic chord; slats extended; positive pitching rotation; rate of descent approximately 200 fps; pilot's head located at $r = 13.4$ ft from the center of gravity; all values are approximate

Time, t (sec)	Angle of attack α (deg)	¹ Centripetal acceleration due to rotation about the center of gravity a_c (g units)	¹ Tangential acceleration due to angular acceleration about the center of gravity a_A (g units)	Component of acceleration directed through long axis of pilot a' (g units)	Component of acceleration normal to long axis of pilot a'' (g units)	Total resultant acceleration of the pilot's head a (g units)
0.033	31	7.7	-0.2	-1.6	-7.5	7.7
.098	48	7.4	-.6	-2.0	-7.1	7.4
.163	62	7.2	-1.0	-2.3	-6.9	7.2
.228	78	6.5	-1.2	-2.4	-6.1	6.6
.293	92	5.7	-1.5	-2.6	-5.3	5.9
.358	105	5.1	-1.6	-2.6	-4.7	5.3
.423	118	4.0	-1.8	-2.5	-3.6	4.4
.488	128	3.5	-1.8	-2.5	-3.1	4.0
.553	139	3.0	-2.0	-2.5	-2.6	3.6
.618	148	2.4	-2.0	-2.5	-1.9	3.0
.683	156	1.7	-2.1	-2.4	-1.2	2.7
.748	164	1.2	-2.0	-2.2	-.8	2.4
.813	172	.8	.8	.6	-1.0	1.1
.878	177	.8	2.0	1.8	-1.2	2.1
.943	-175	1.9	.8	.4	-2.0	2.1
1.008	-167	2.1	.6	.2	-2.2	2.2
1.073	-158	2.2	.7	.3	-2.3	2.3
1.138	-148	2.6	1.3	.8	-2.8	2.9
1.203	-138	5.4	1.9	.9	-5.6	5.7
1.268	-126	3.9	2.5	1.8	-4.3	4.6
1.333	-112	10.6	3.0	.9	-11.1	11.1
1.398	-98	13.7	3.3	.7	-13.8	13.8
1.463	-83	9.3	2.1	.3	-9.7	9.7
1.528	-66	9.2	.0	-1.8	-9.0	9.2
1.593	-47	8.4	-1.3	-3.0	-8.0	8.5
1.658	-29	7.9	-.7	-2.2	-7.6	7.9
1.723	-14	7.9	-.5	-2.0	-7.6	7.9

¹Values obtained from figure 16.

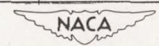

TABLE XXIII.- TUMBLING CHARACTERISTICS OF MODEL 14

[Center of gravity, 24.1 percent mean aerodynamic chord; ailerons neutral;
rudders neutral; tunnel airspeed, 147 feet per second, full scale]

Configuration	Loading	Method of launching model	Behavior of model (a)		
			Longitudinal stick position		
			Full back	Neutral	Full forward
Clean	Normal	Released from nose-up simulated whip stall	D	D	D
Do-----	----do----	Positive pitching rotation	D	D	D

^aKey

D No tumble; dived with no oscillation in pitch.



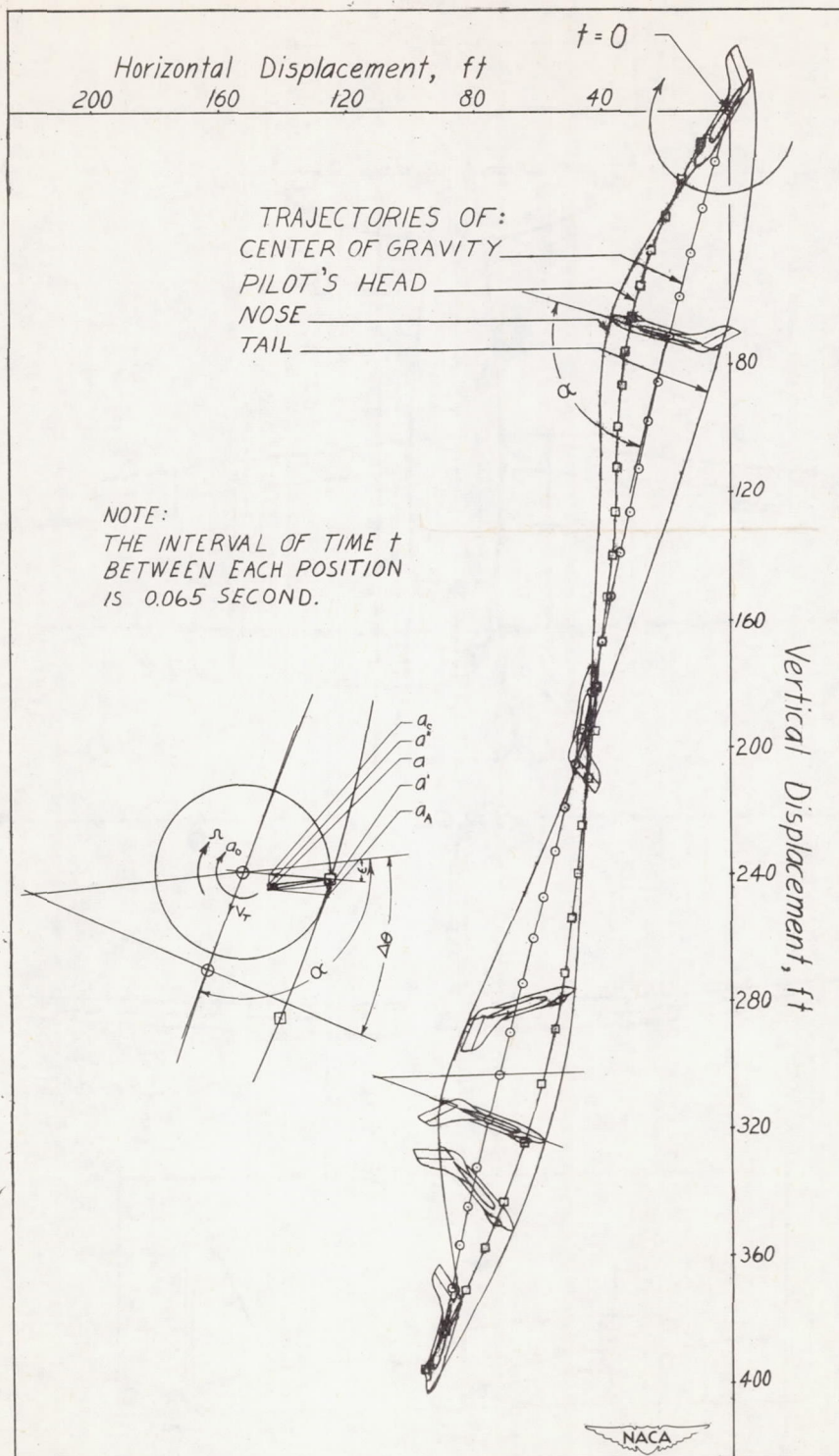

Figure 1.- Full-scale path of motion obtained from model data of model 13 during a tumble. Elevators deflected full-up; slats extended; center of gravity located 24 percent mean aerodynamic chord.

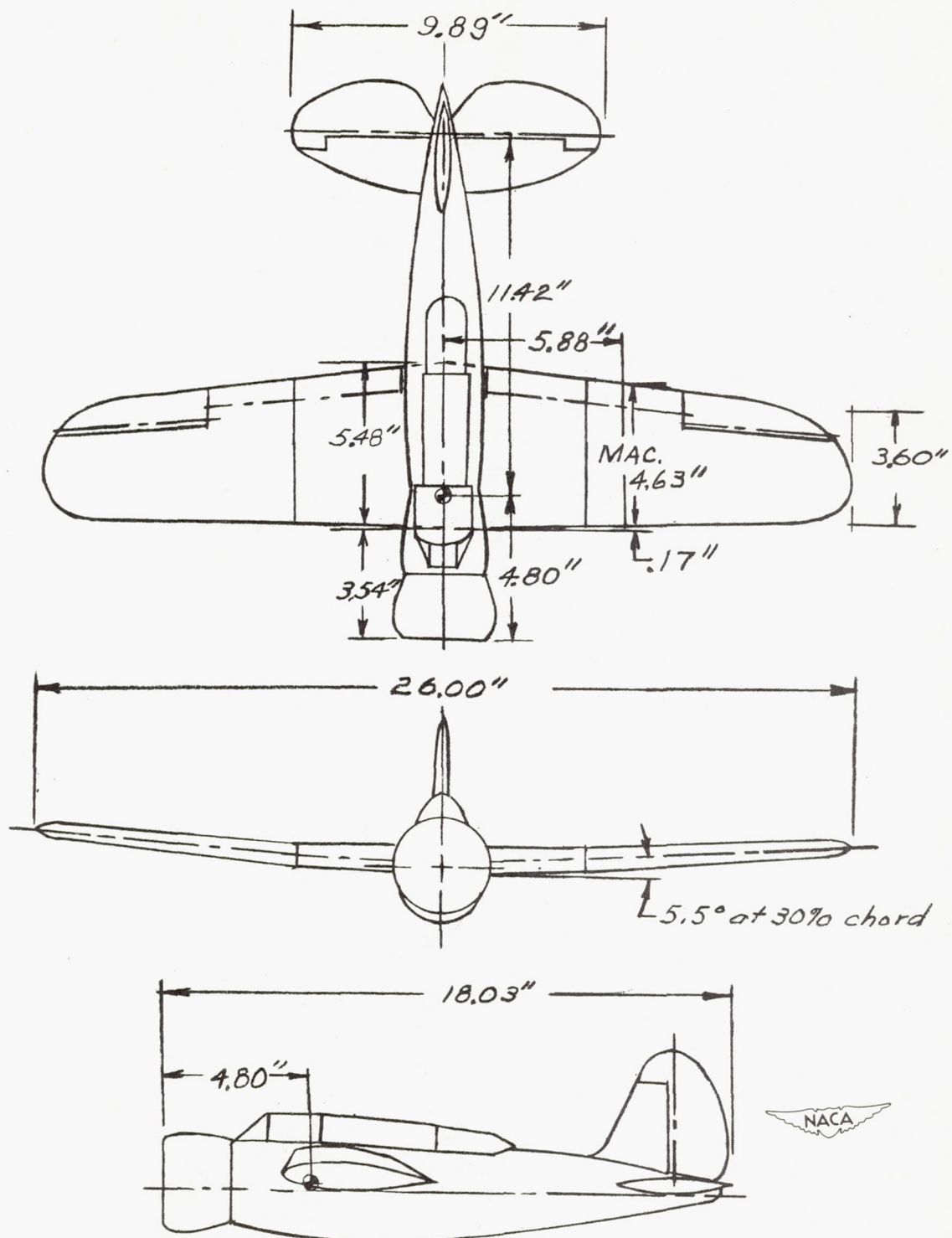

Figure 2.- Three-view drawing of model 1 as tested in the Langley 20-foot free-spinning tunnel. Center-of-gravity location shown is for the normal loading.

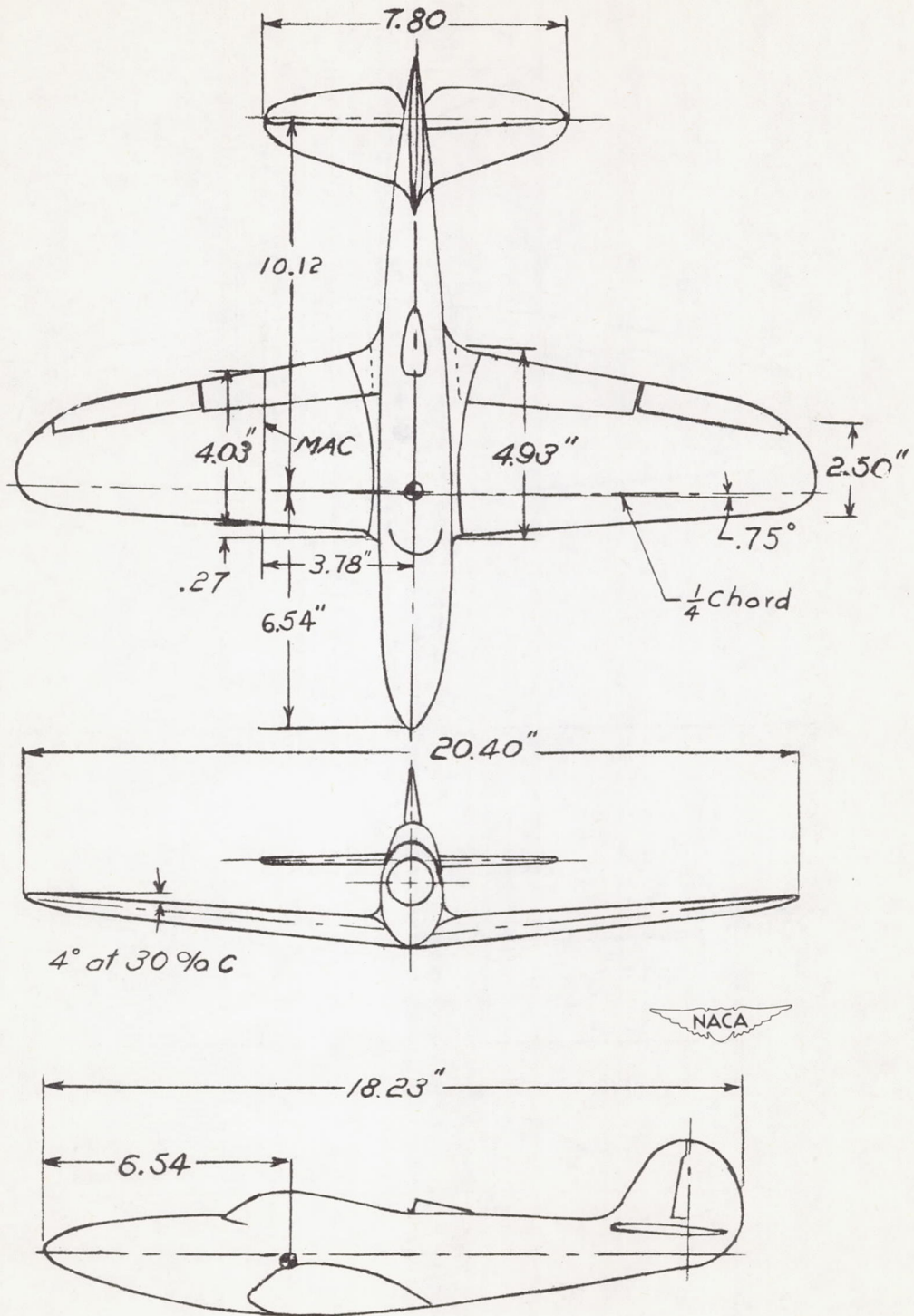

Figure 3.- Three-view drawing of model 2 as tested in the Langley 20-foot free-spinning tunnel. Center-of-gravity location shown is for the normal loading.

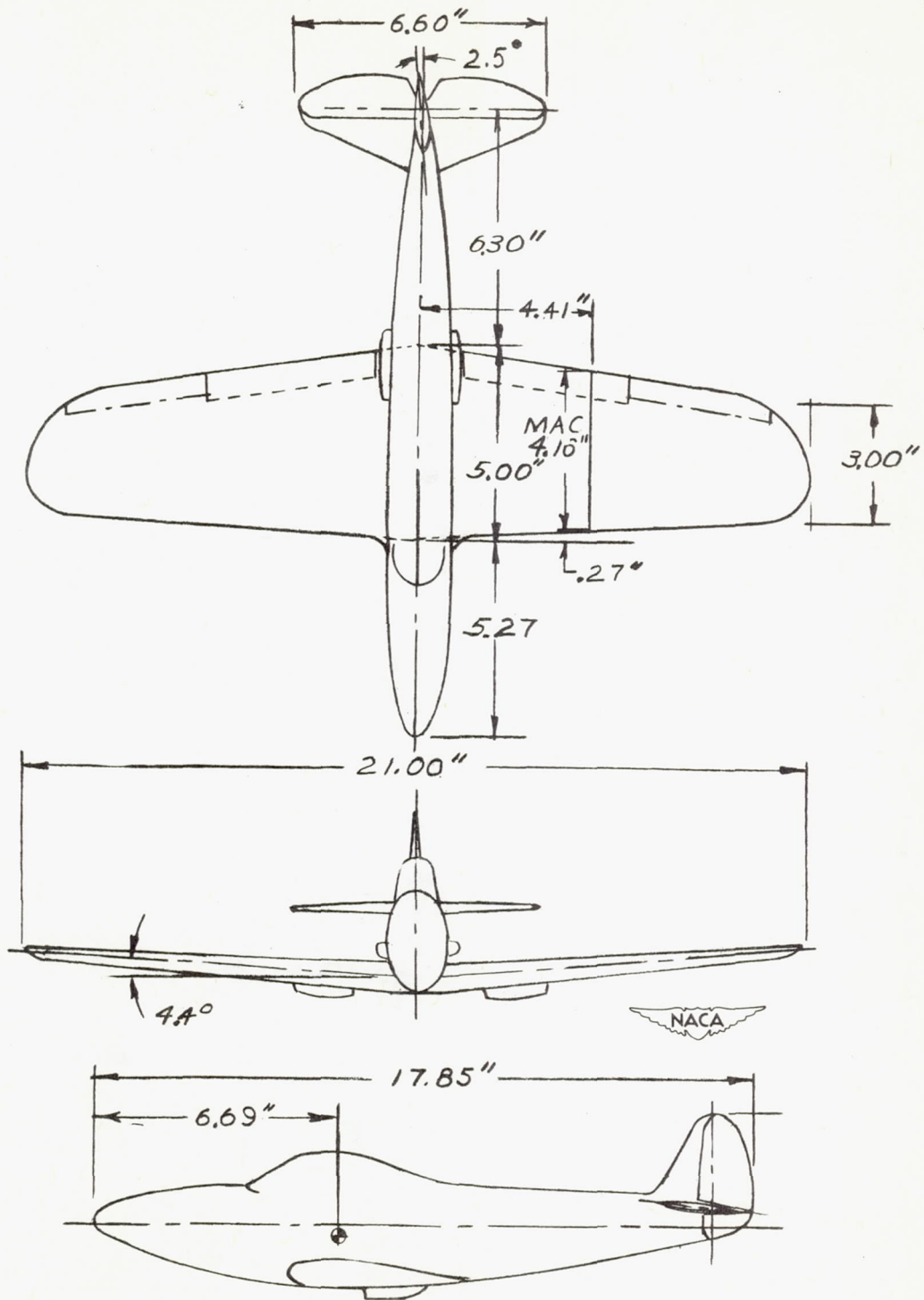

Figure 4.- Three-view drawing of model 3 as tested in the Langley 20-foot free-spinning tunnel. Center-of-gravity location shown is for the normal loading.

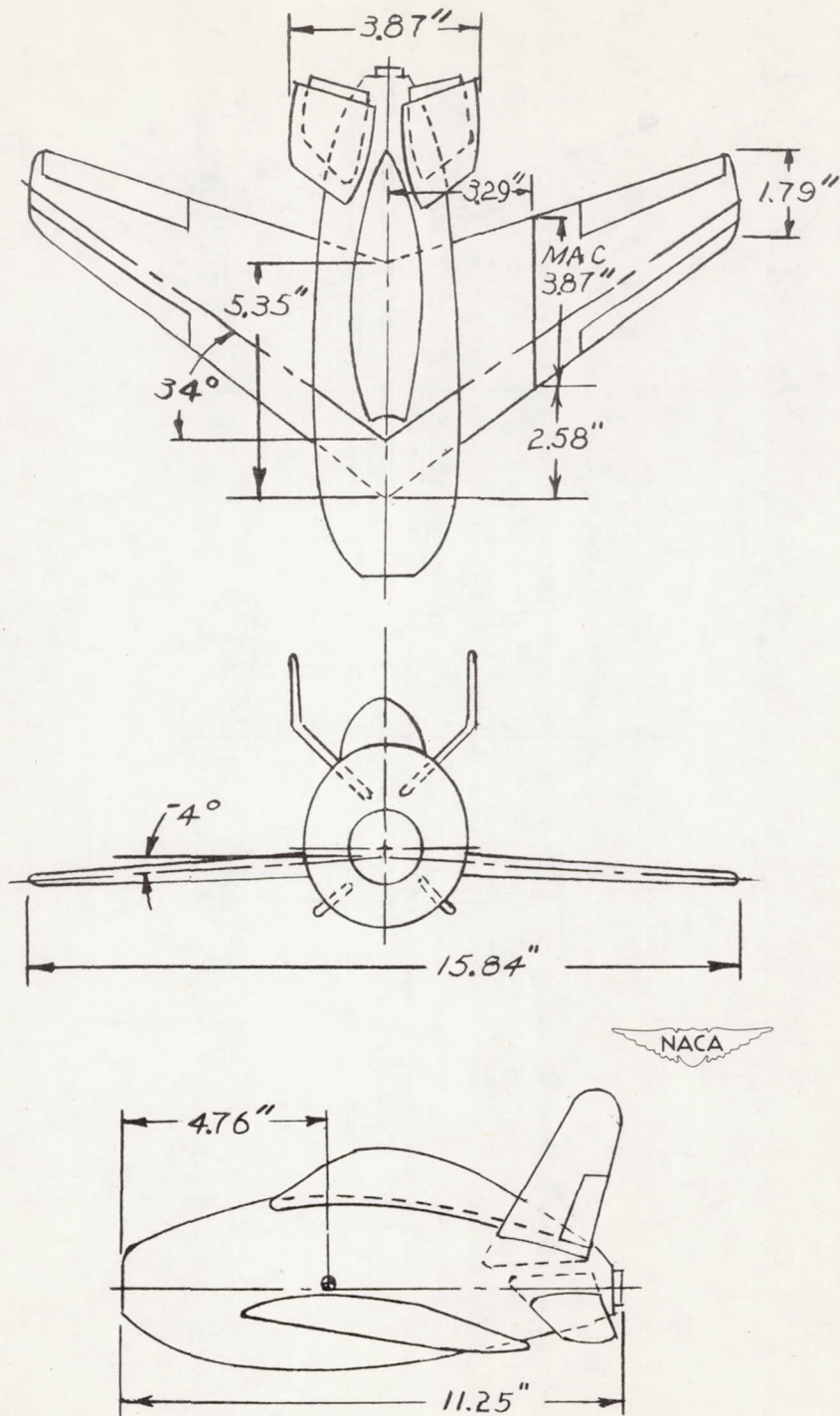
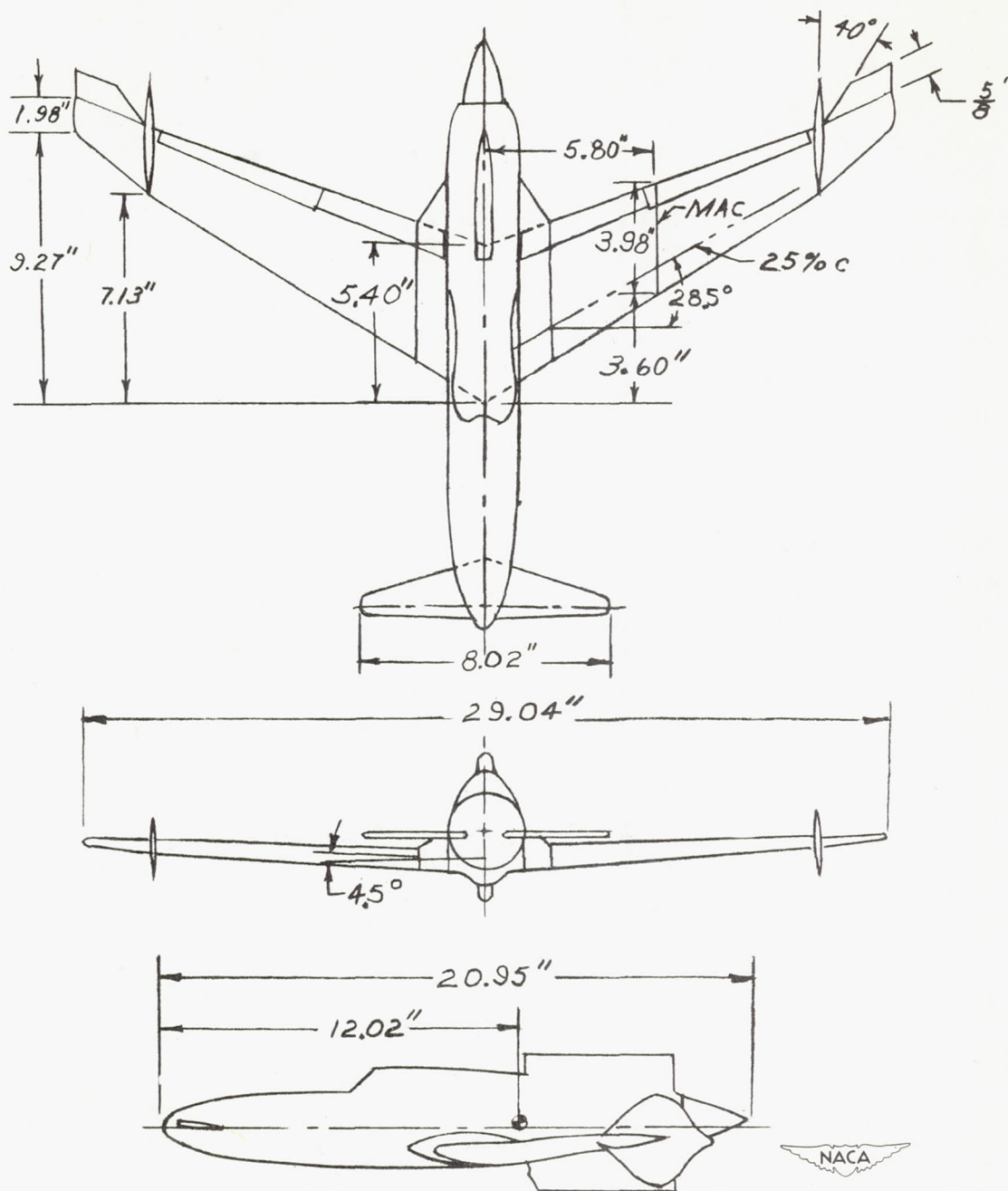
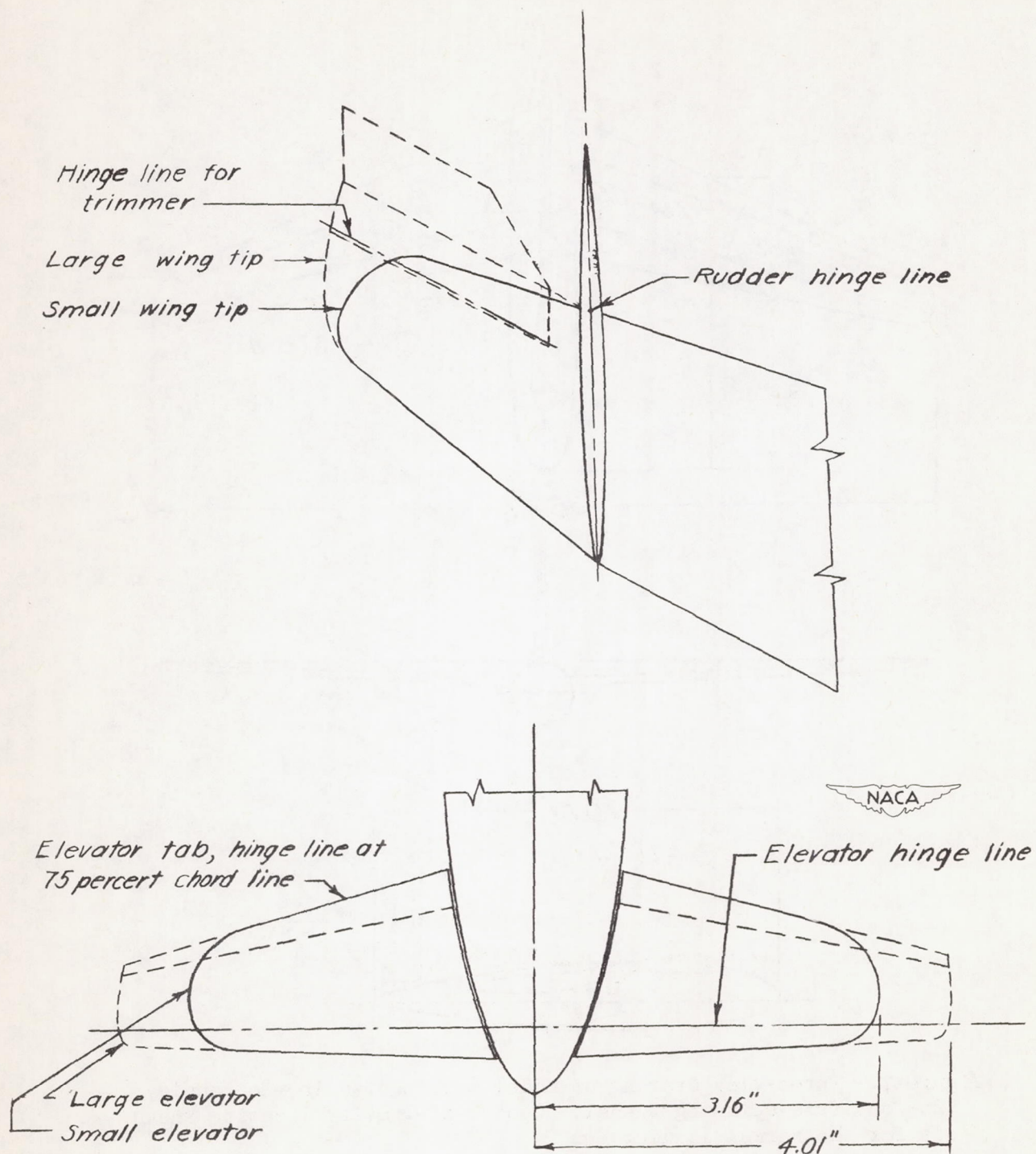

Figure 5.- Three-view drawing of model 4 as tested in the Langley 20-foot free-spinning tunnel. Center-of-gravity location shown is for the normal loading.



(a) Three-view drawing. Center-of-gravity location shown is for normal loading. Revised elevator and wing tips installed.

Figure 6.- Model 5 with revisions as tested in the Langley 20-foot free-spinning tunnel.



(b) Original and revised configurations of wing tips and elevators.

Figure 6.- Concluded.

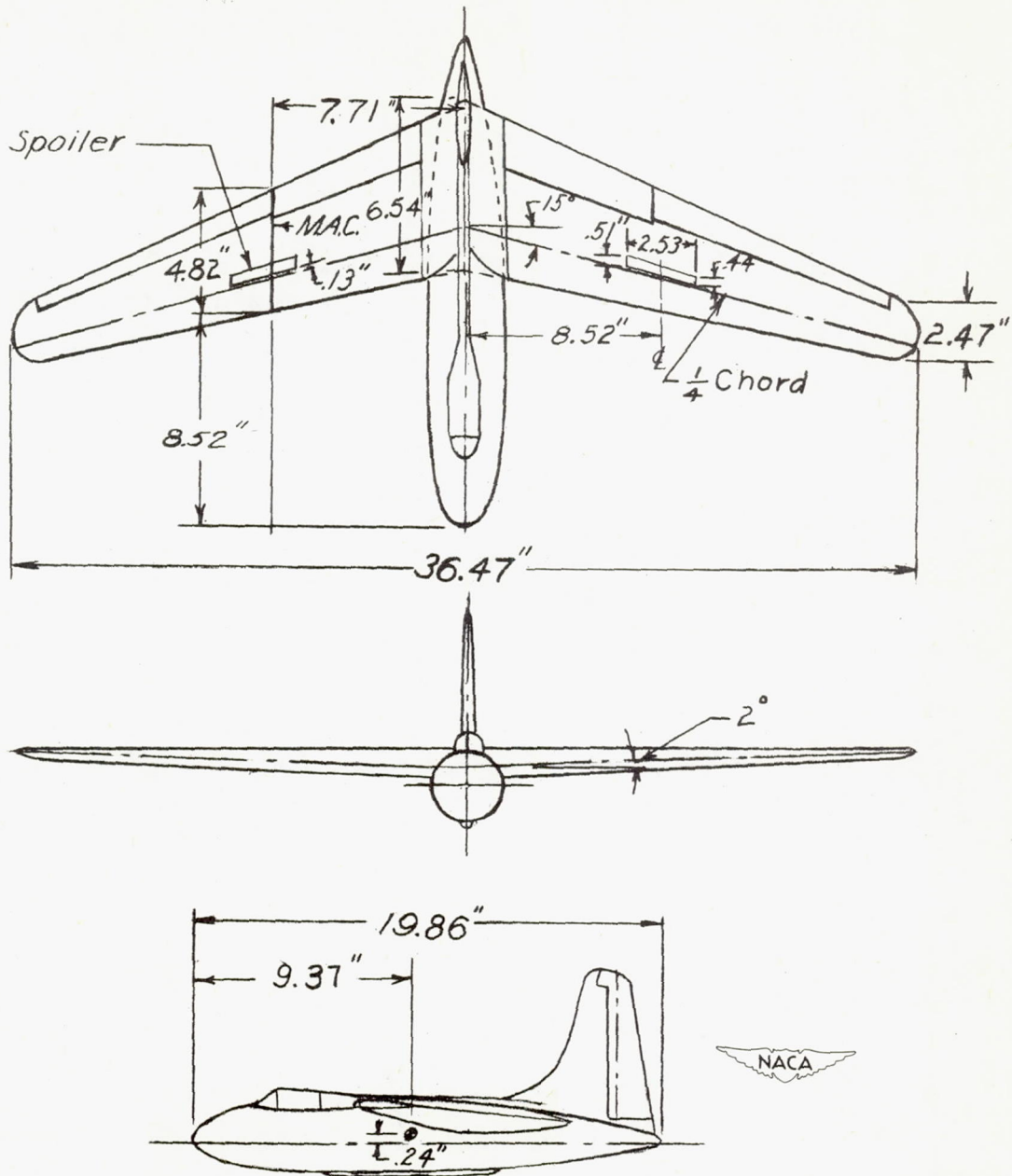

Figure 7.- Three-view drawing of model 6 as tested in the Langley 20-foot free-spinning tunnel. Center-of-gravity location shown is for the normal loading.

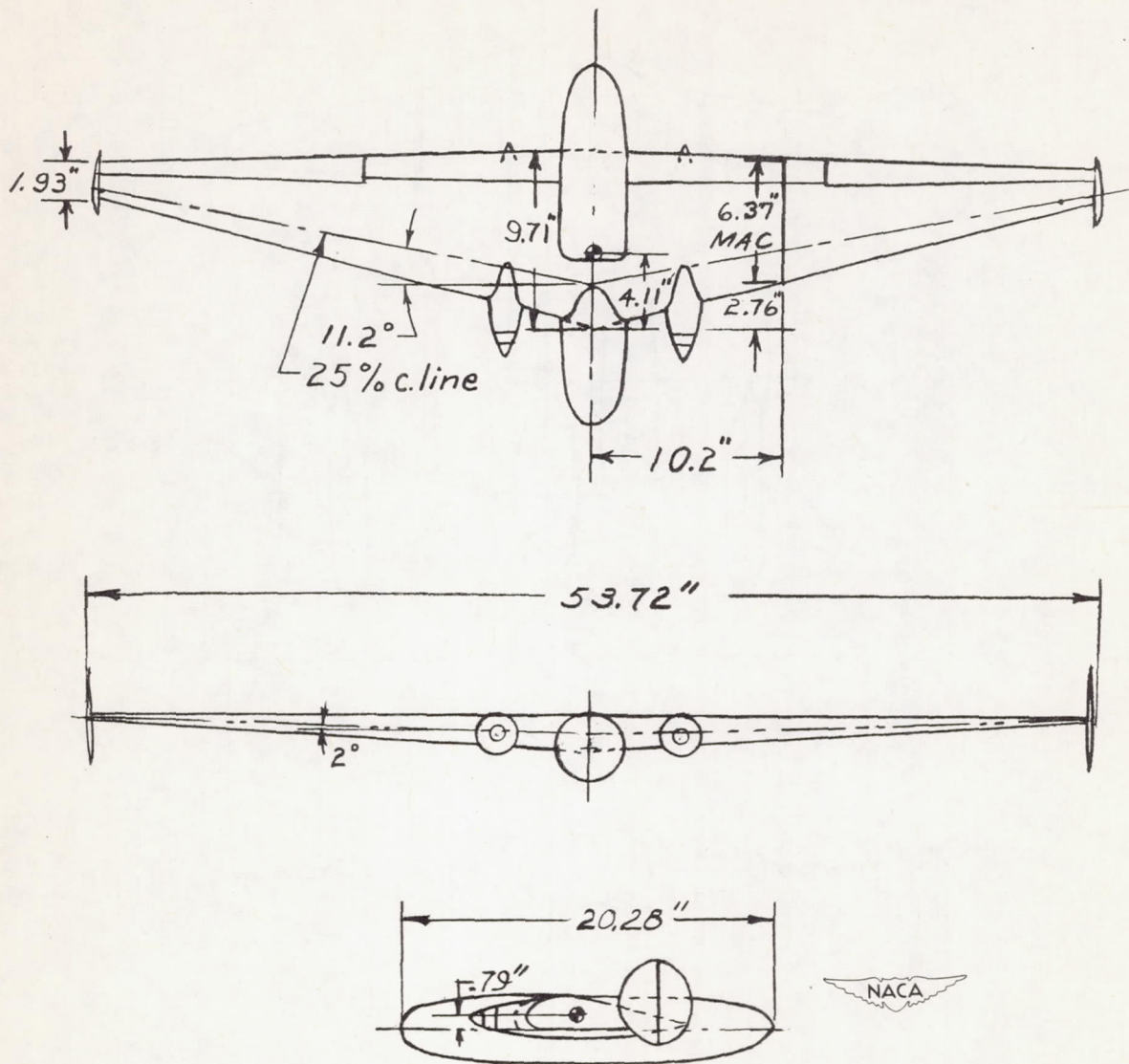

Figure 8.- Three-view drawing of model 7 as tested in the Langley 20-foot free-spinning tunnel. Center-of-gravity location shown is for the normal loading.

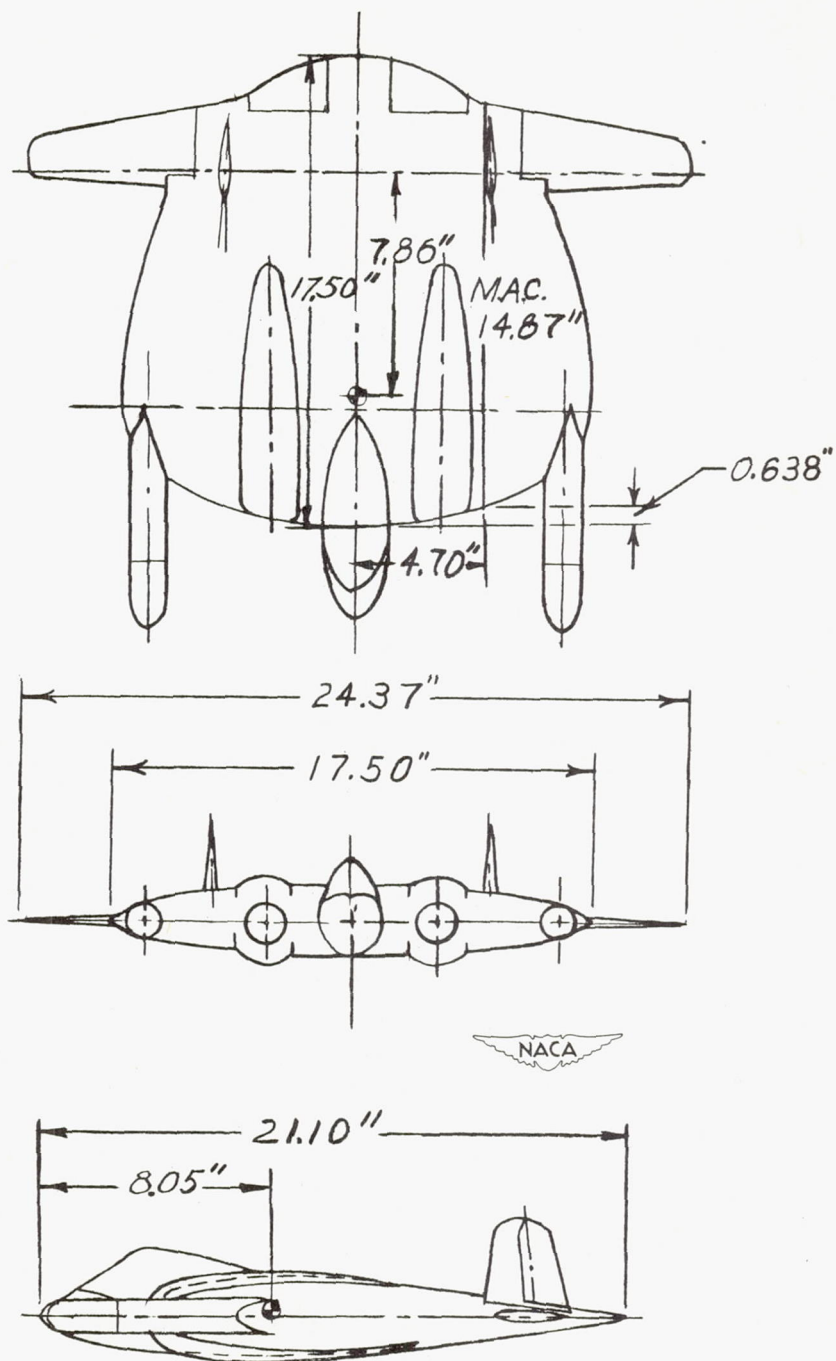
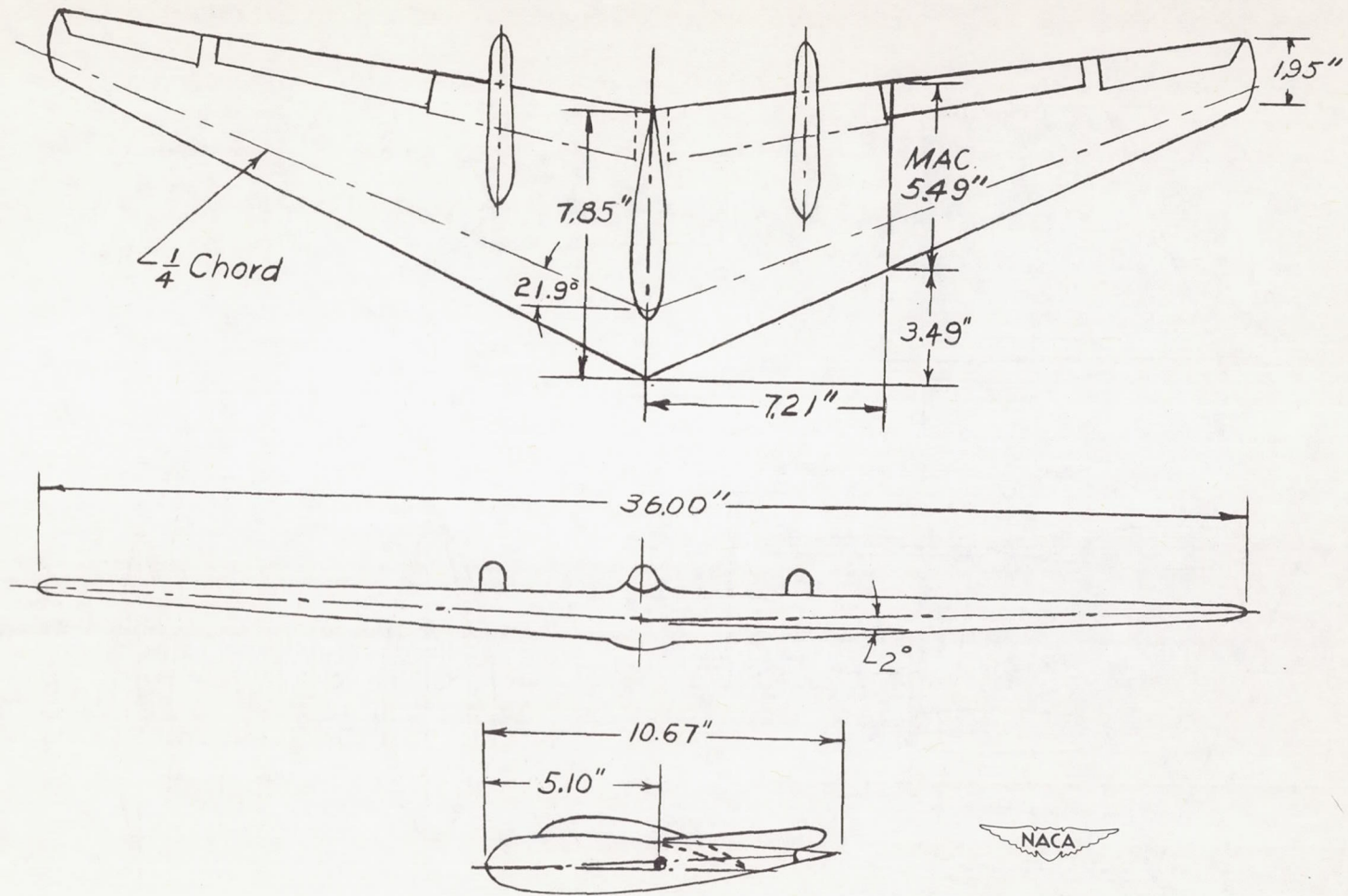
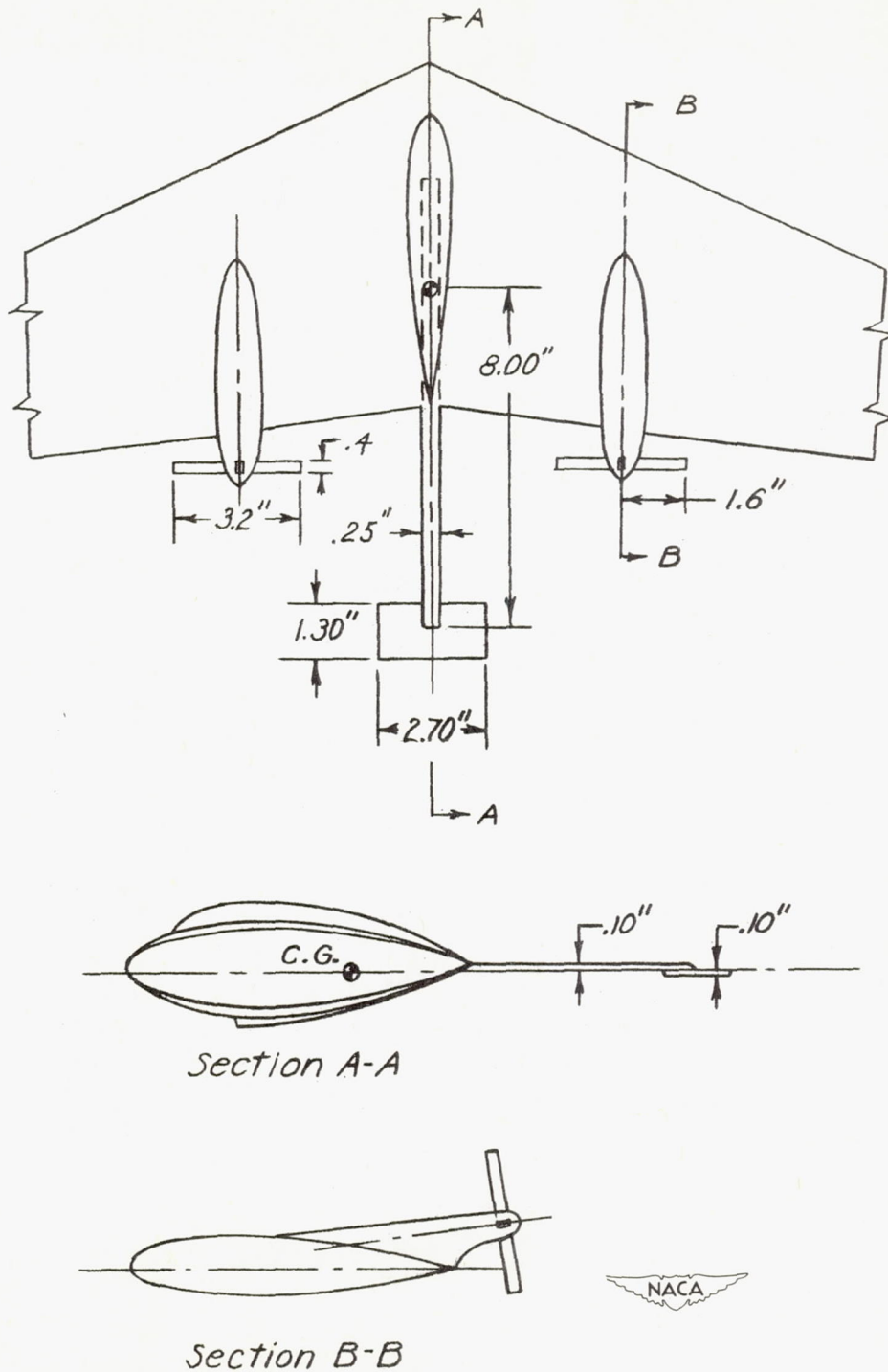

Figure 9.- Three-view drawing of model 8 as tested in the Langley 20-foot free-spinning tunnel. Center-of-gravity location shown is for the normal loading.



(a) Three-view drawing. Center of gravity shown is for normal loading.

Figure 10.- Model 9 with revision as tested in the Langley 20-foot free-spinning tunnel.



(b) Horizontal tail and simulated propeller fin area.

Figure 10.- Continued.

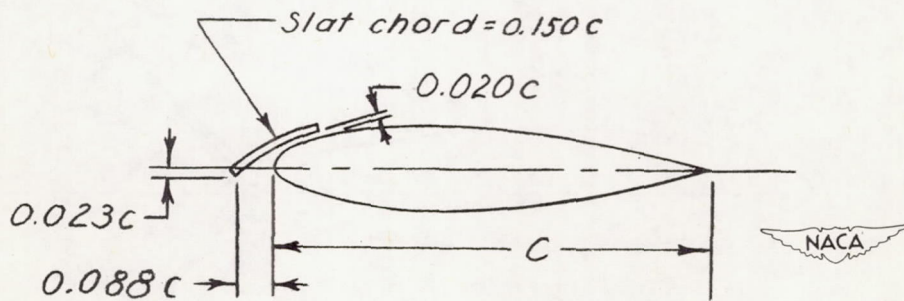
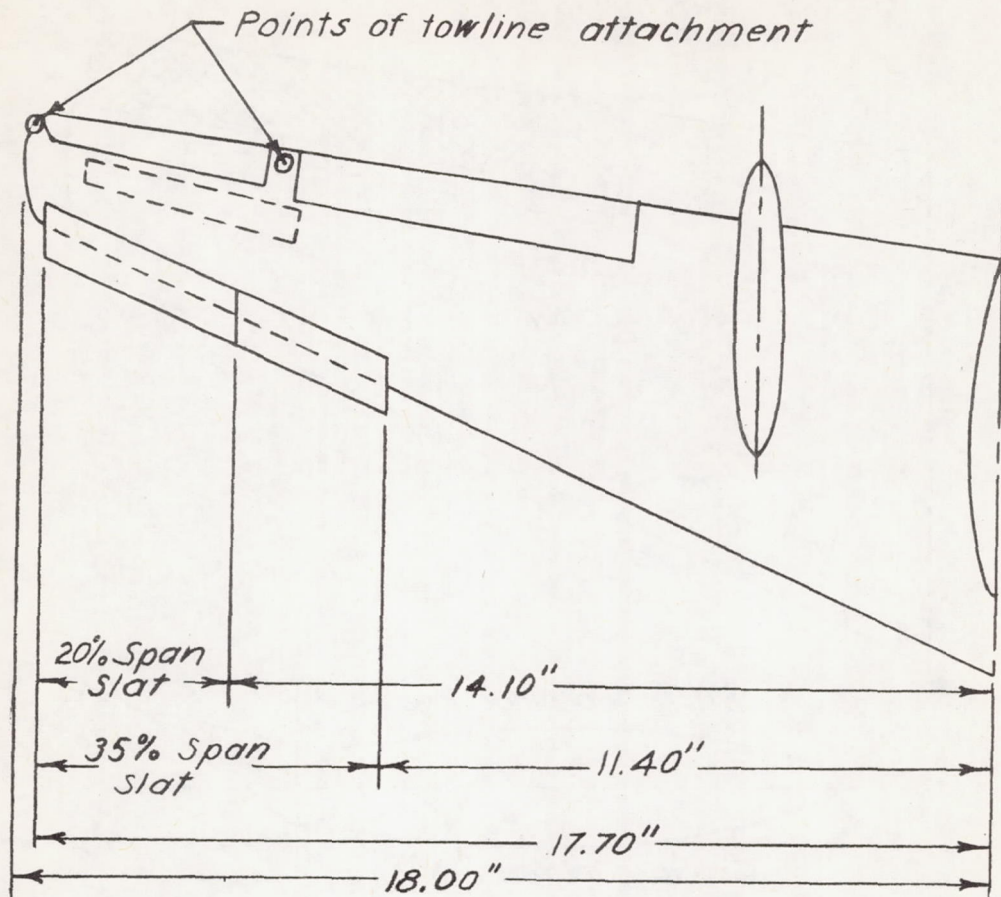

(c) Slats and parachute towline attachment points.

Figure 10.- Continued.

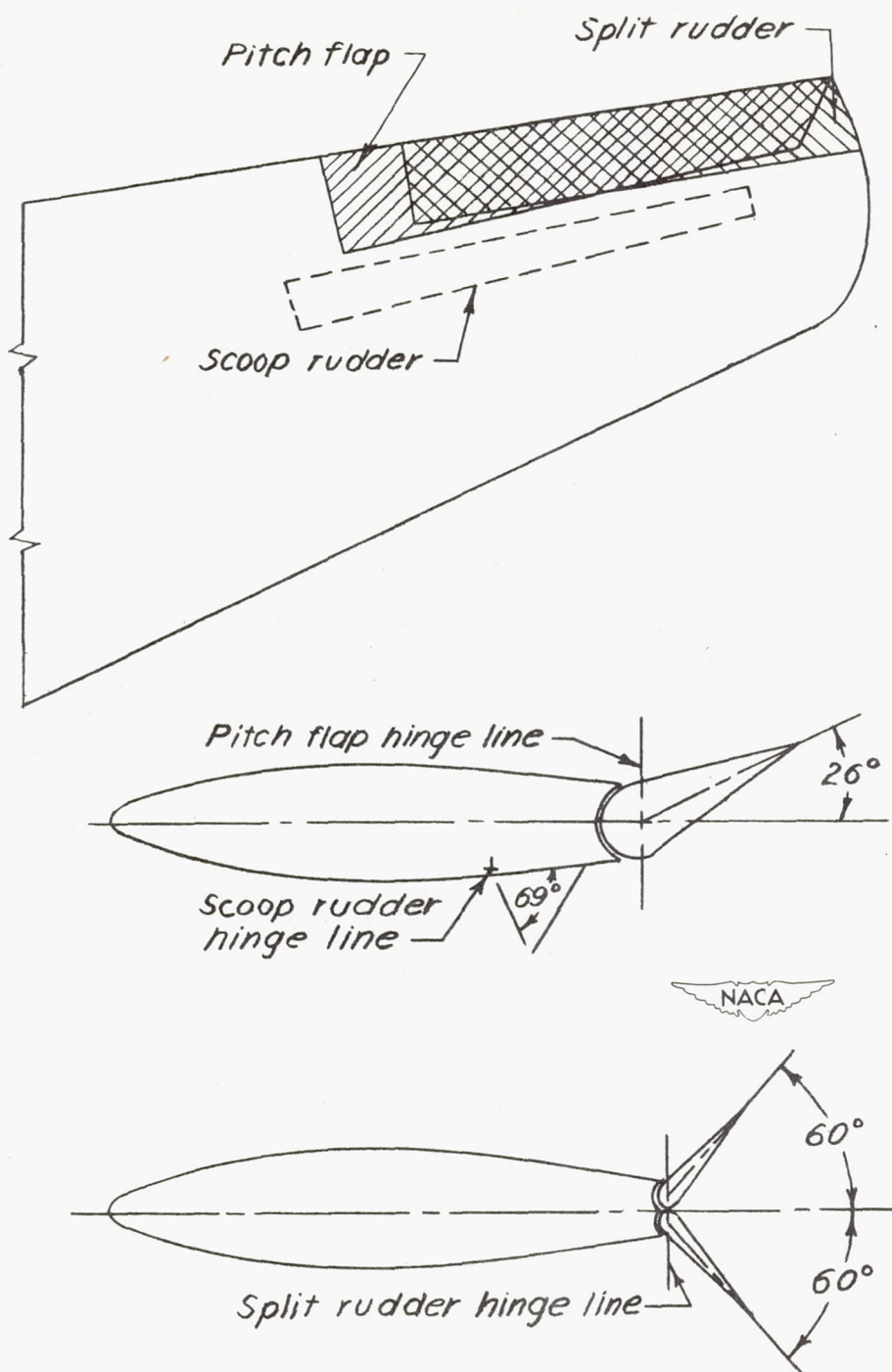

(d) Split rudders, scoop rudders, and pitch flaps.

Figure 10.- Concluded.

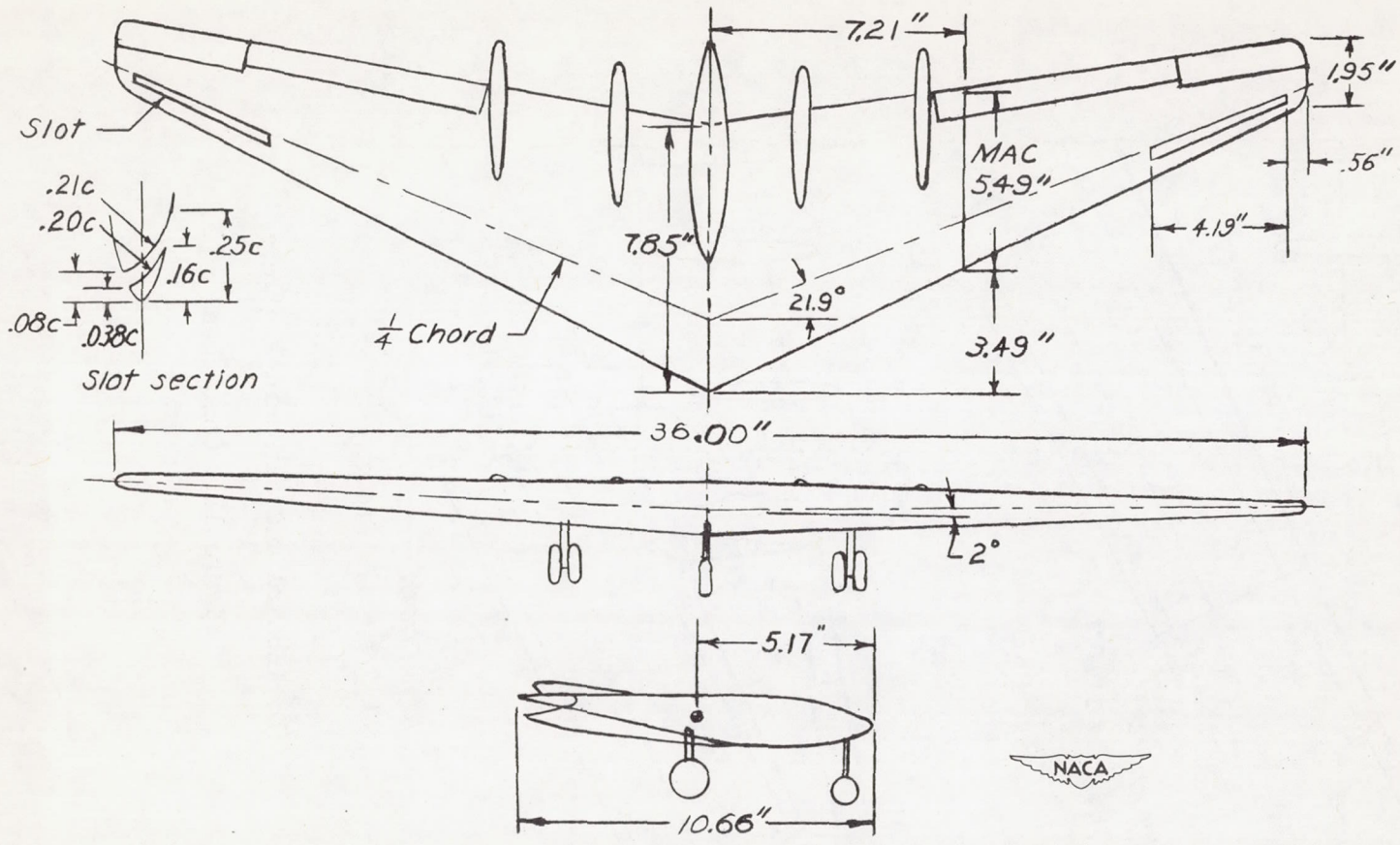

(a) Three-view drawing. Center-of-gravity position shown is for normal loading. Landing gear extended and slats open.

Figure 11.- Model 10 with revisions as tested in the Langley 20-foot free-spinning tunnel.

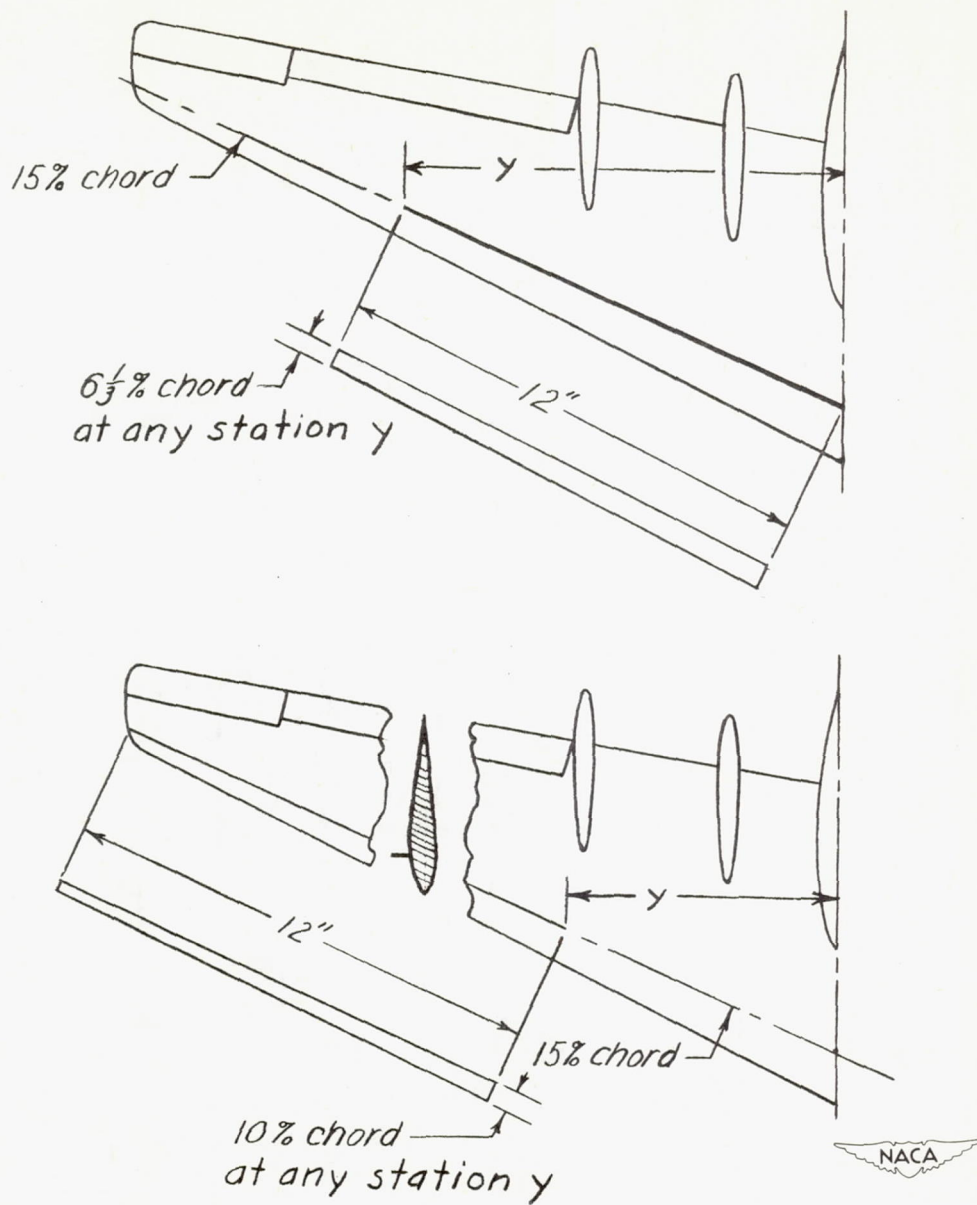

(b) Inboard and outboard spoilers.

Figure 11.- Concluded.

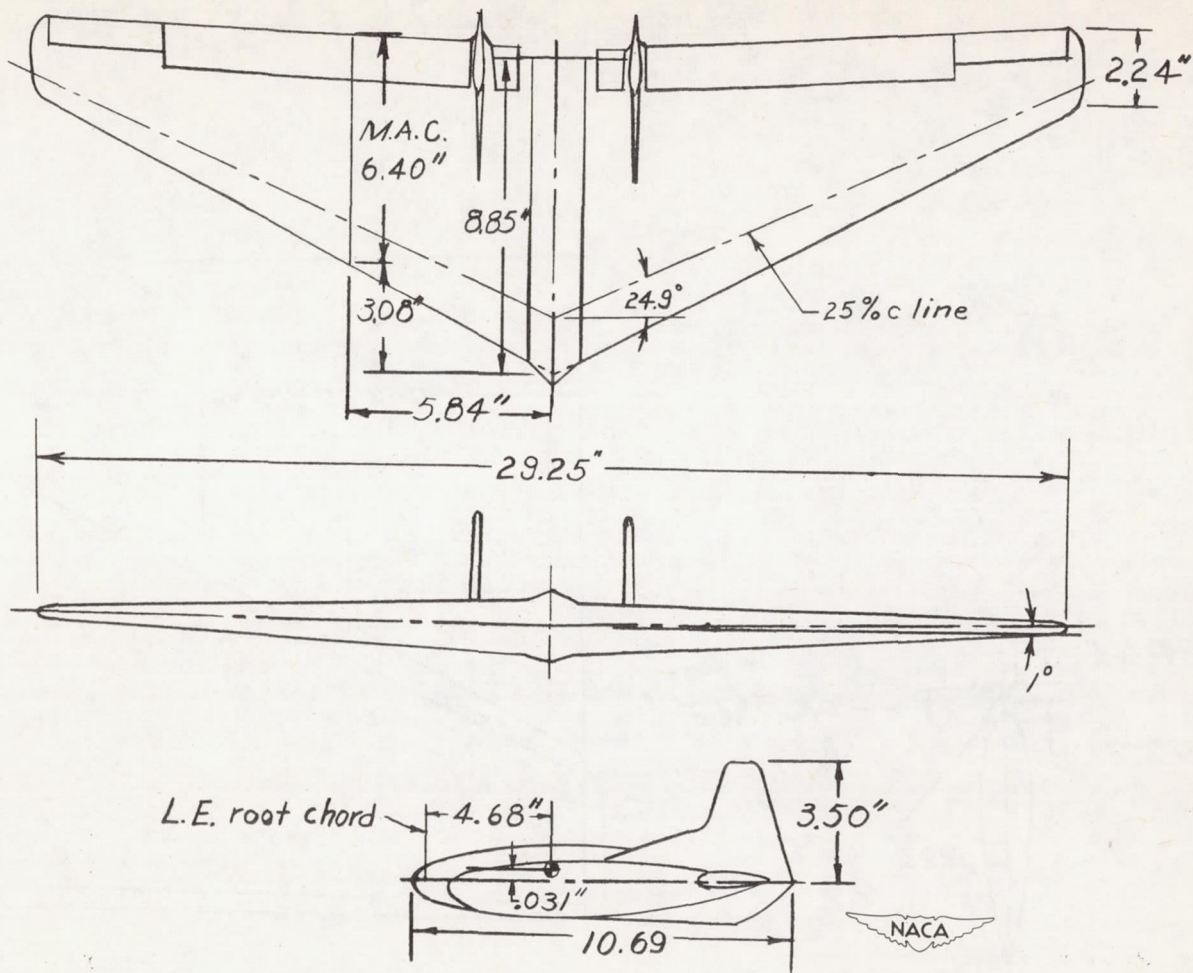

(a) Three-view drawing. Center-of-gravity location shown is for the normal loading.
 Figure 12.- Model 11 with revisions as tested in the Langley 20-foot free-spinning tunnel.

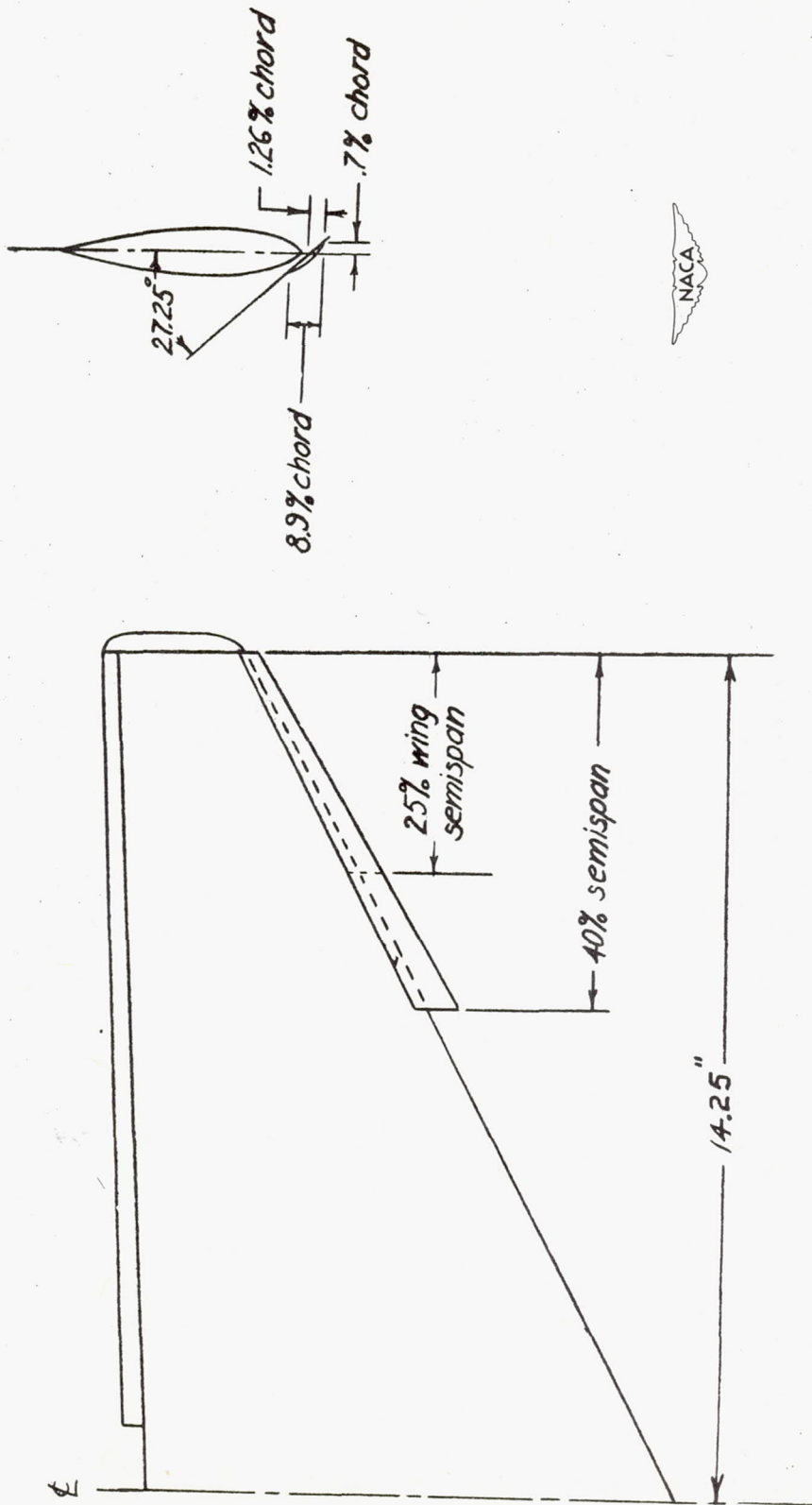

(b) Slats.

Figure 12.- Continued.

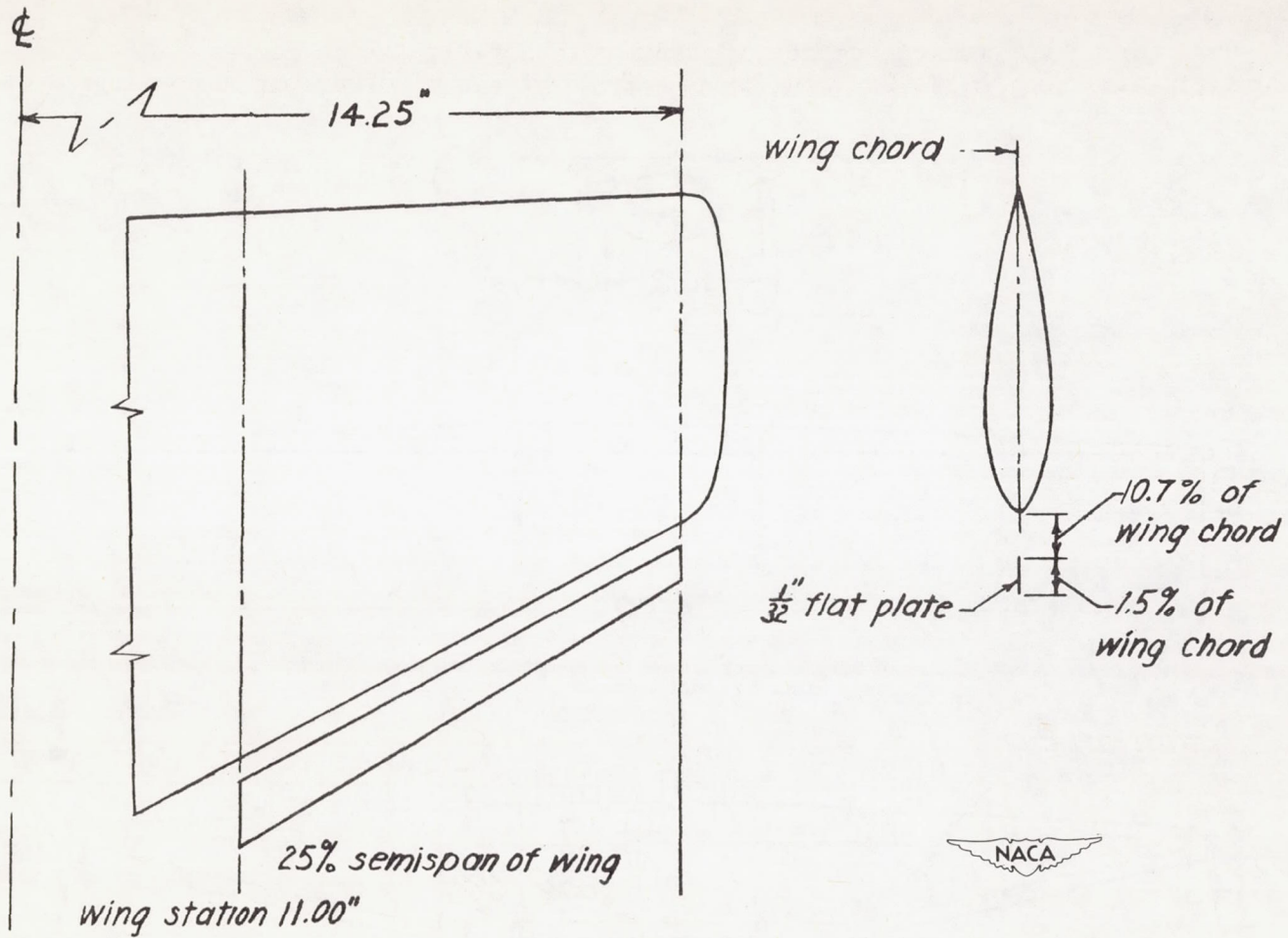

(c) Auxiliary airfoils.

Figure 12.- Concluded.

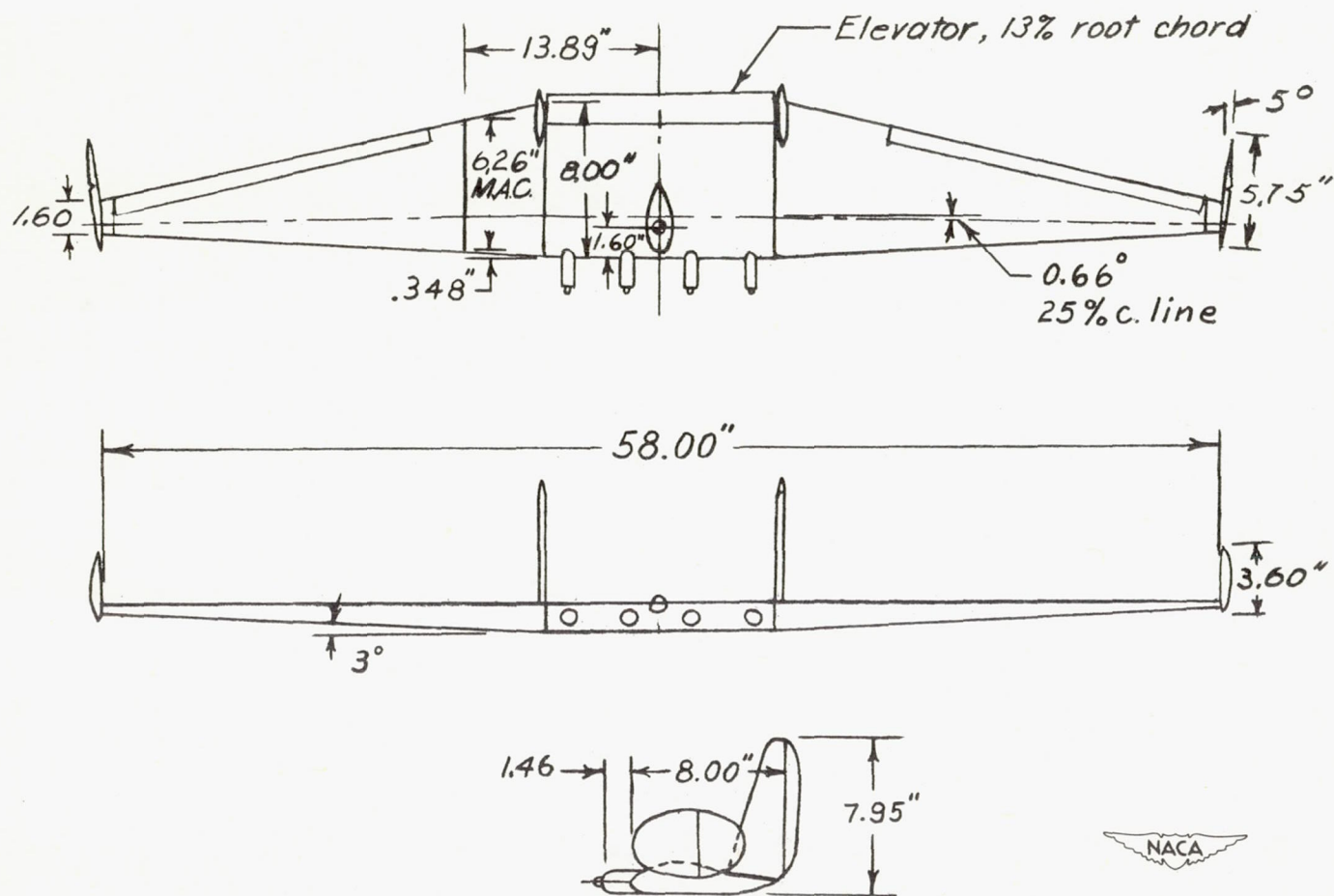

Figure 13.- Three-view drawing of model 12 as tested in the Langley 20-foot free-spinning tunnel. Center-of-gravity location shown is for the normal loading.

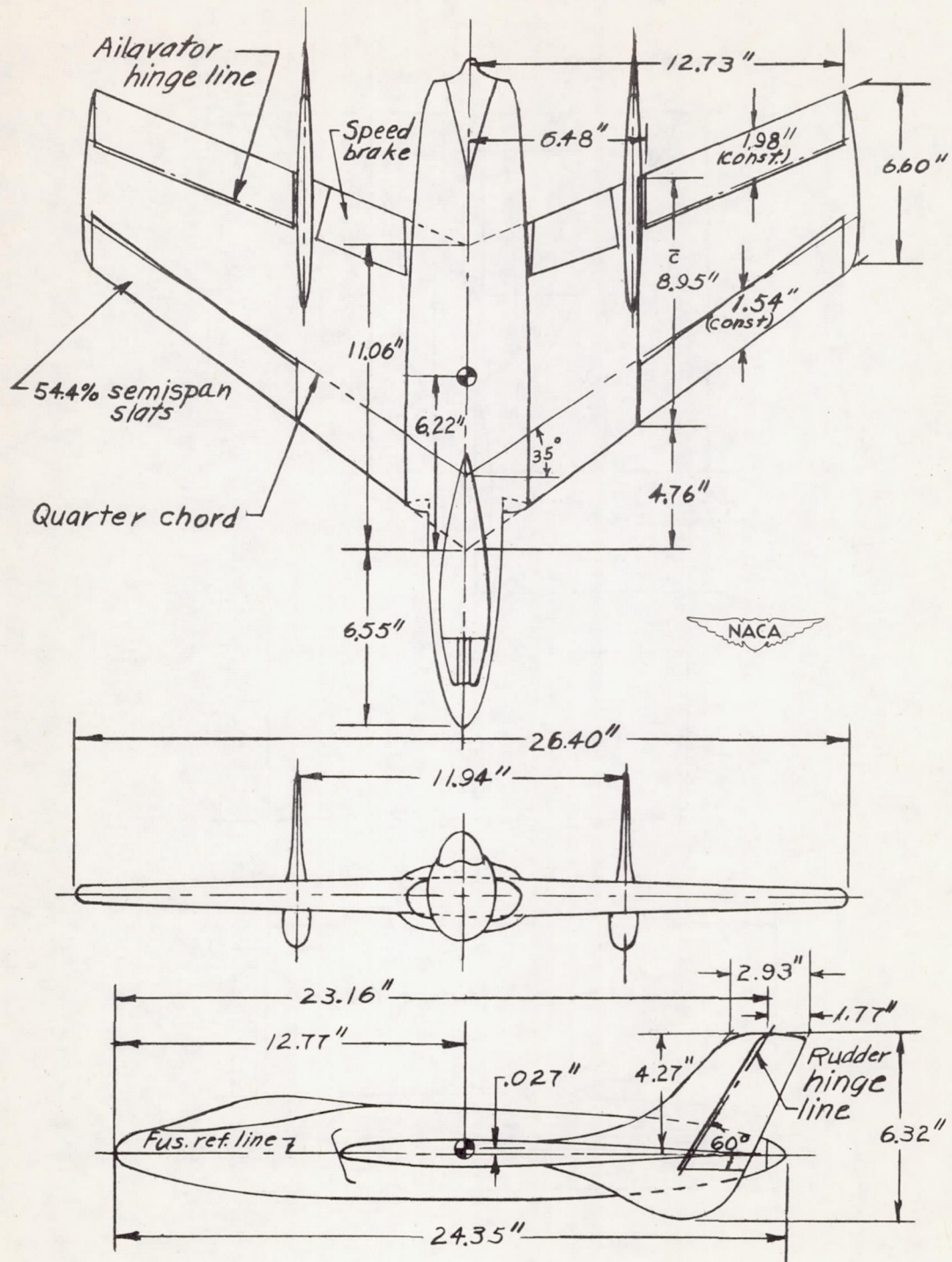

Figure 14.- Three-view drawing of model 13 as tested in the Langley 20-foot free-spinning tunnel. Center of gravity shown is for the normal loading.

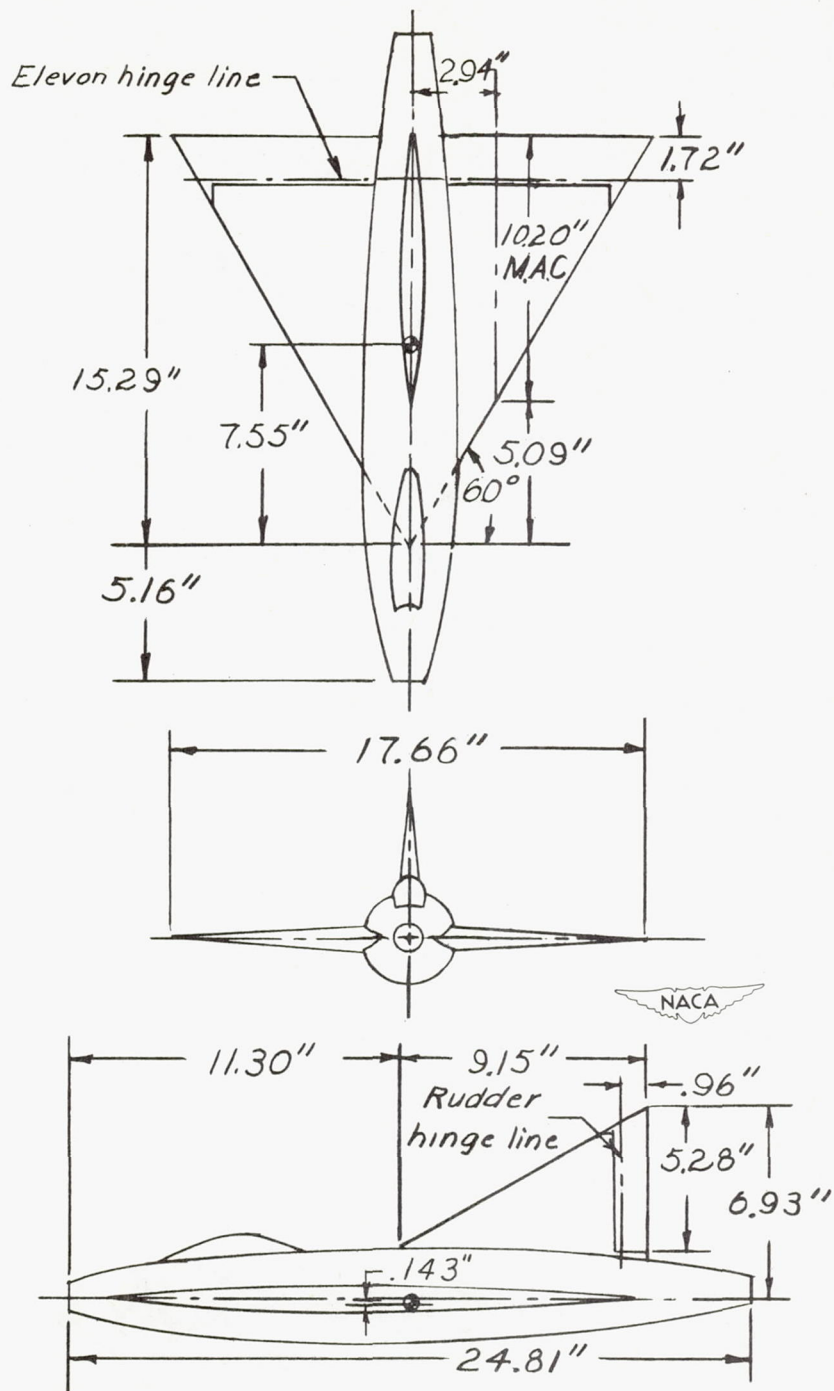

Figure 15.- Three-view drawing of model 14 as tested in the Langley 20-foot free-spinning tunnel. Center of gravity shown is for the normal loading.

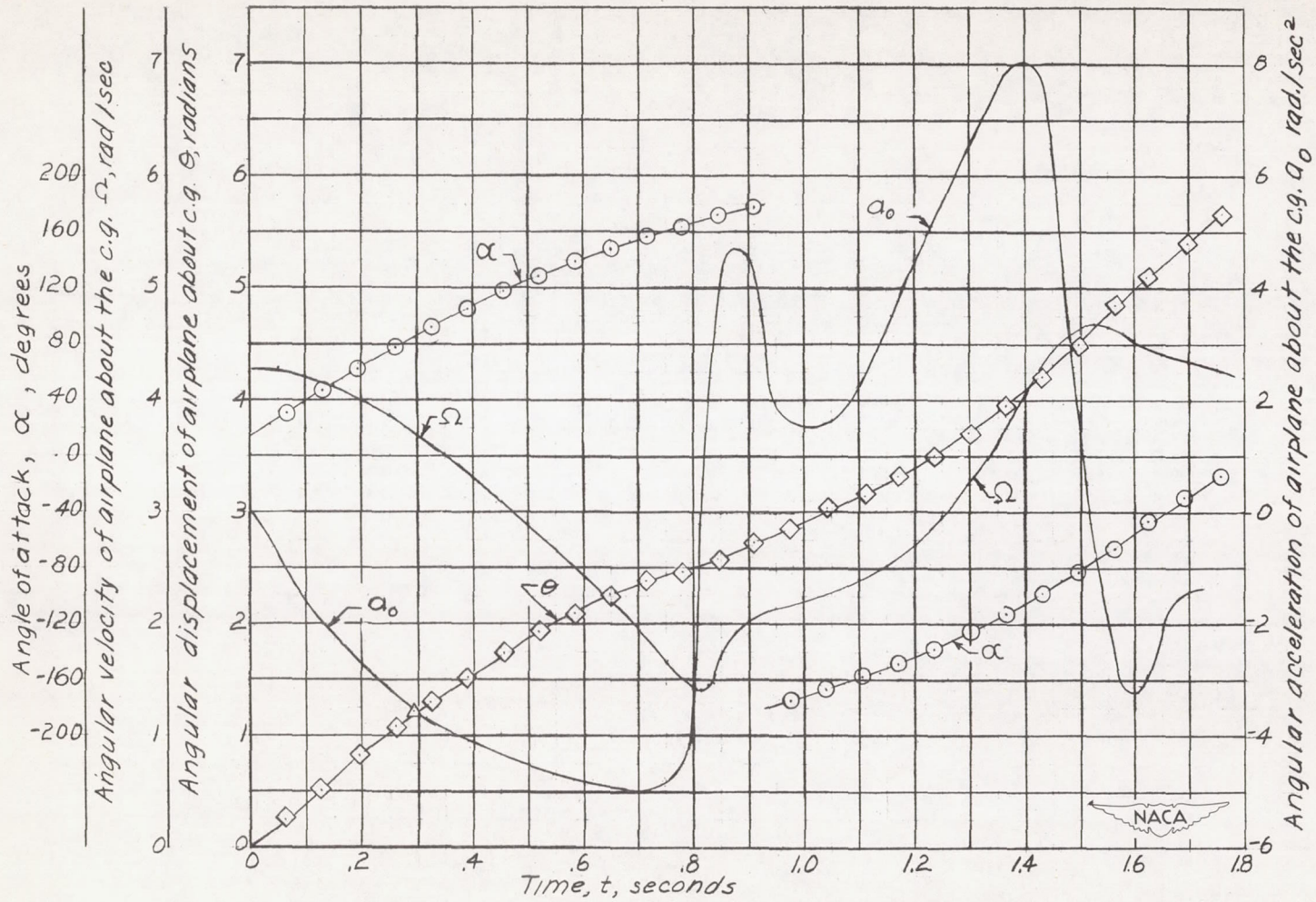
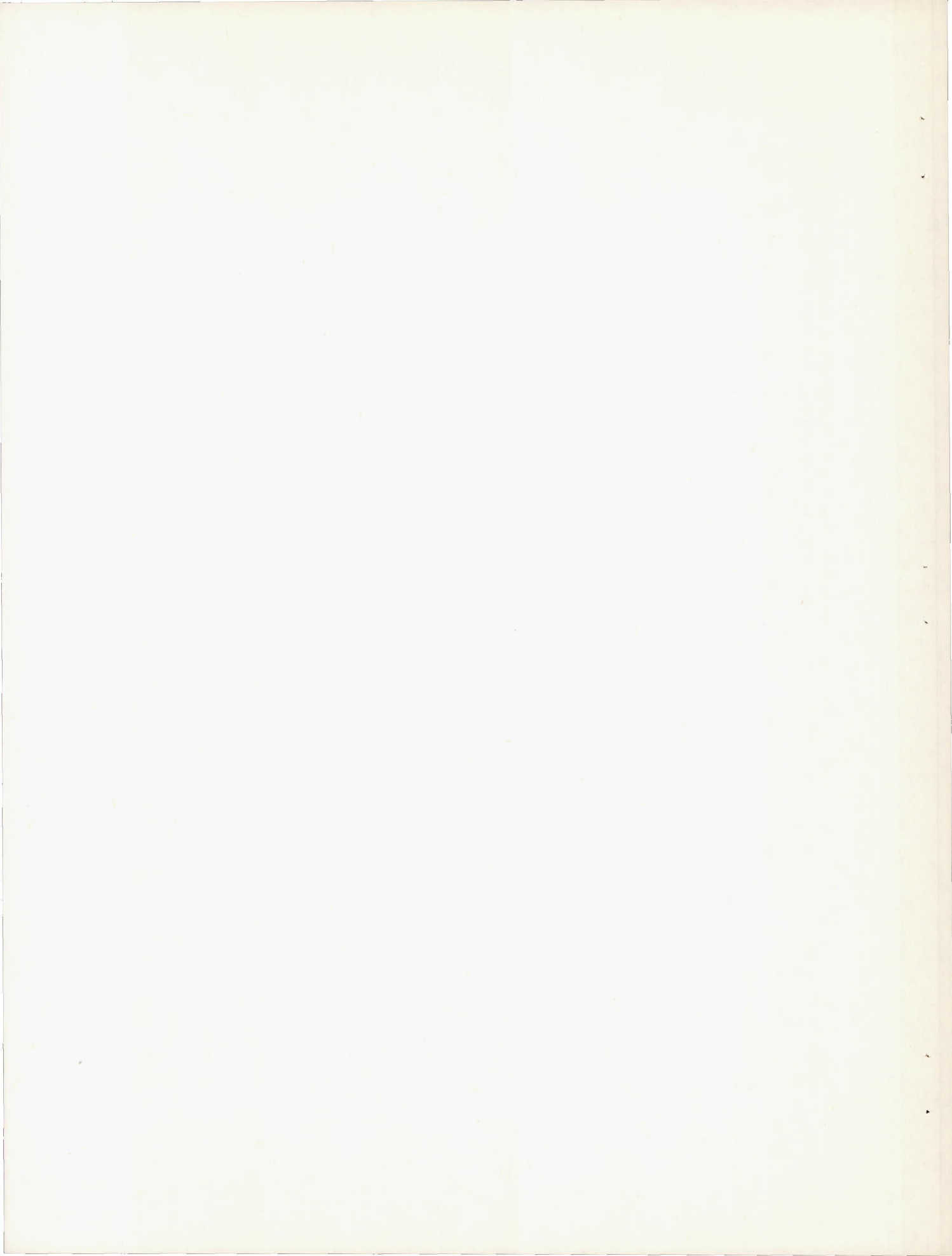

Figure 16.- Graphical determination of the centripetal and angular acceleration during a tumble of model 13. Basic data given in figure 1.



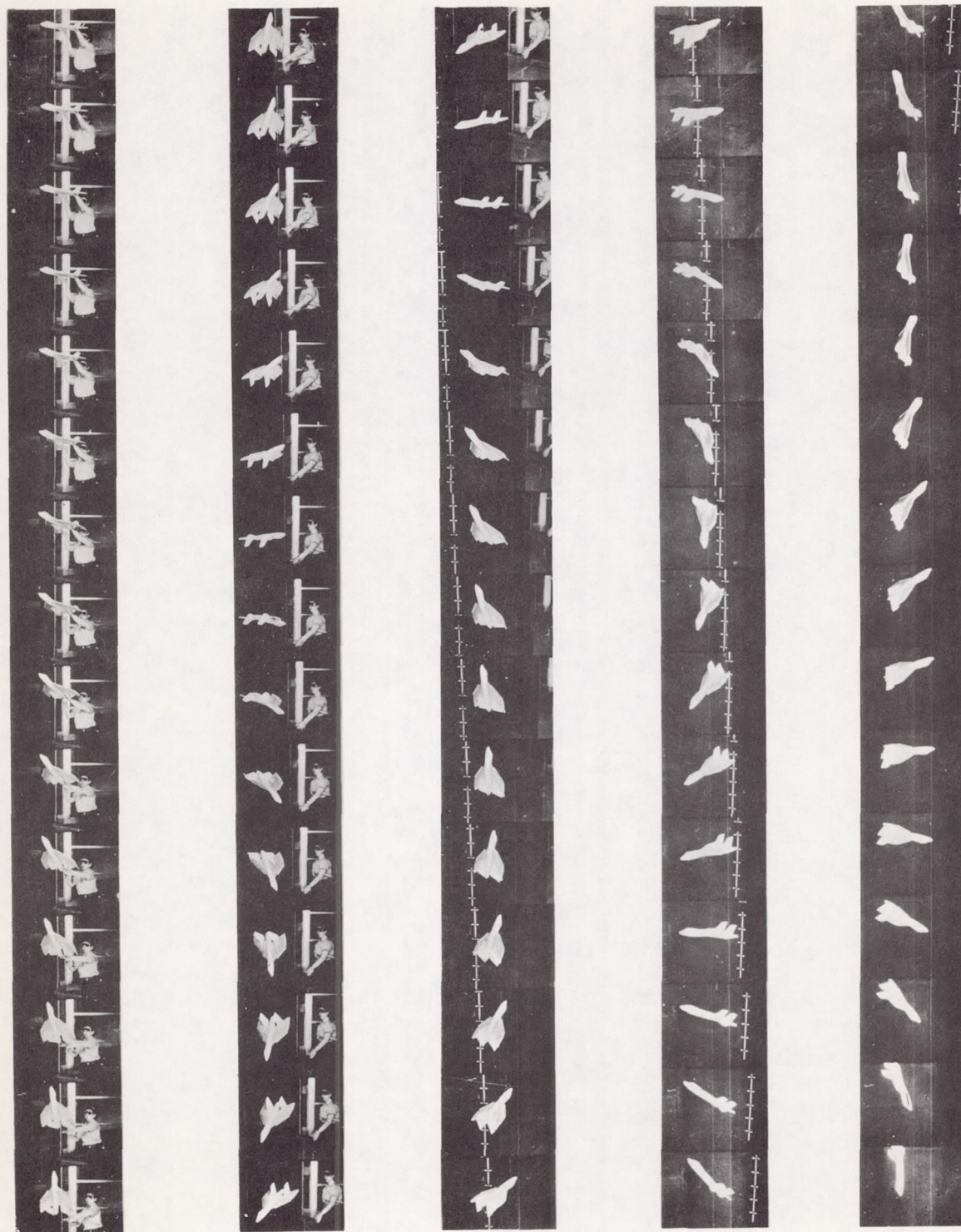

Figure 17.- Typical motion, which is represented by the symbol A in the key to the data, in which the model tumbles.

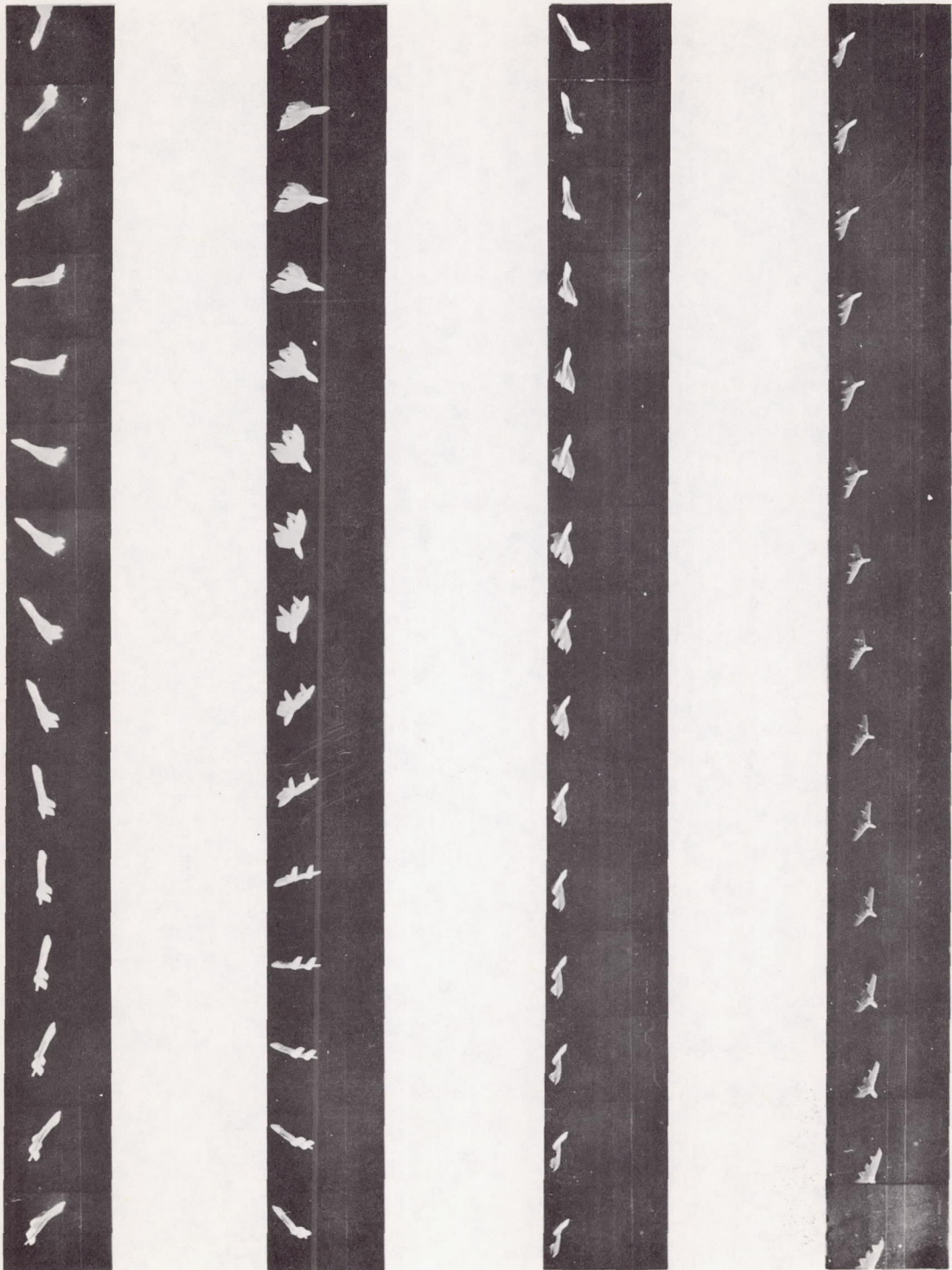

Figure 17.- Concluded.

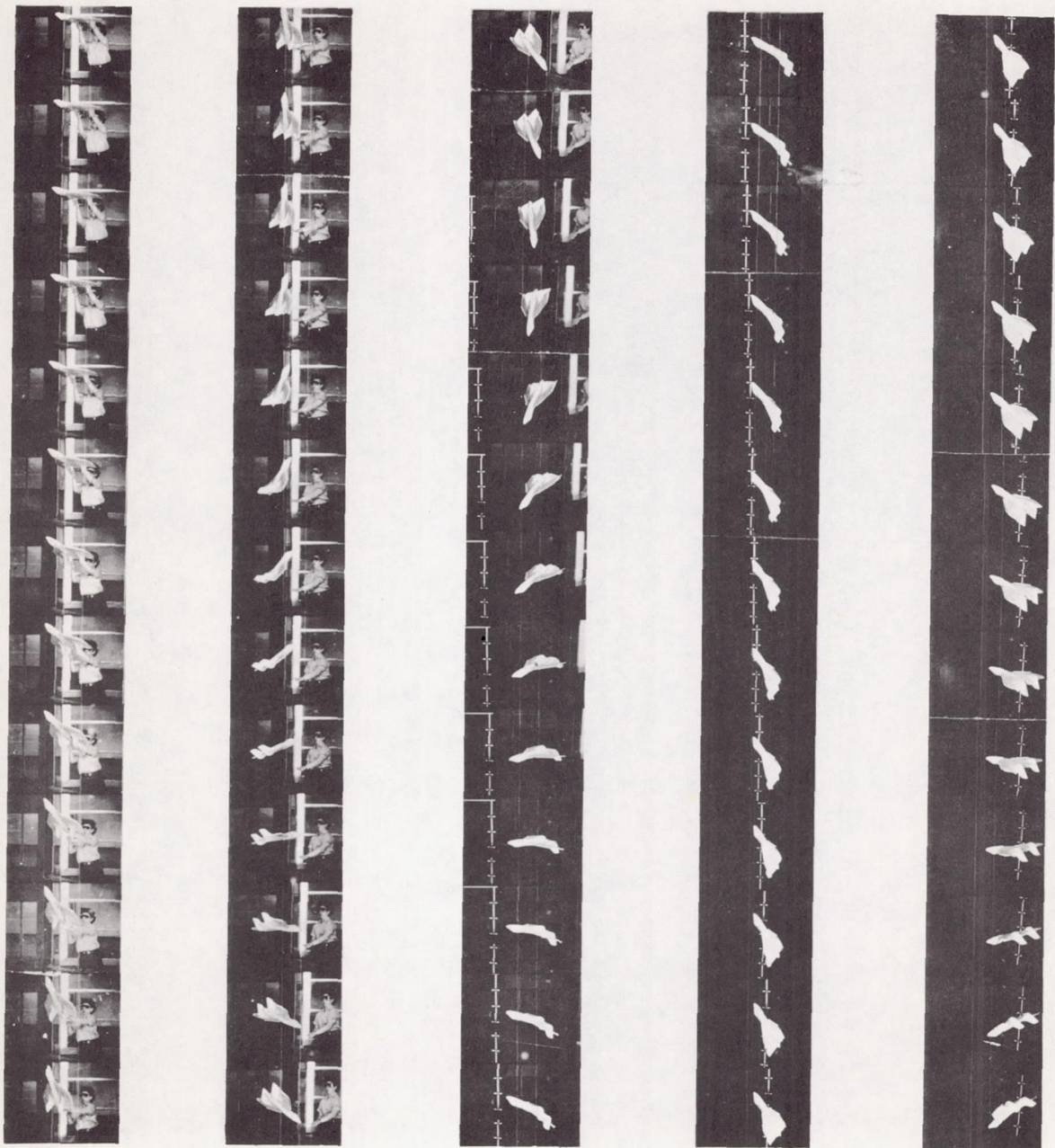
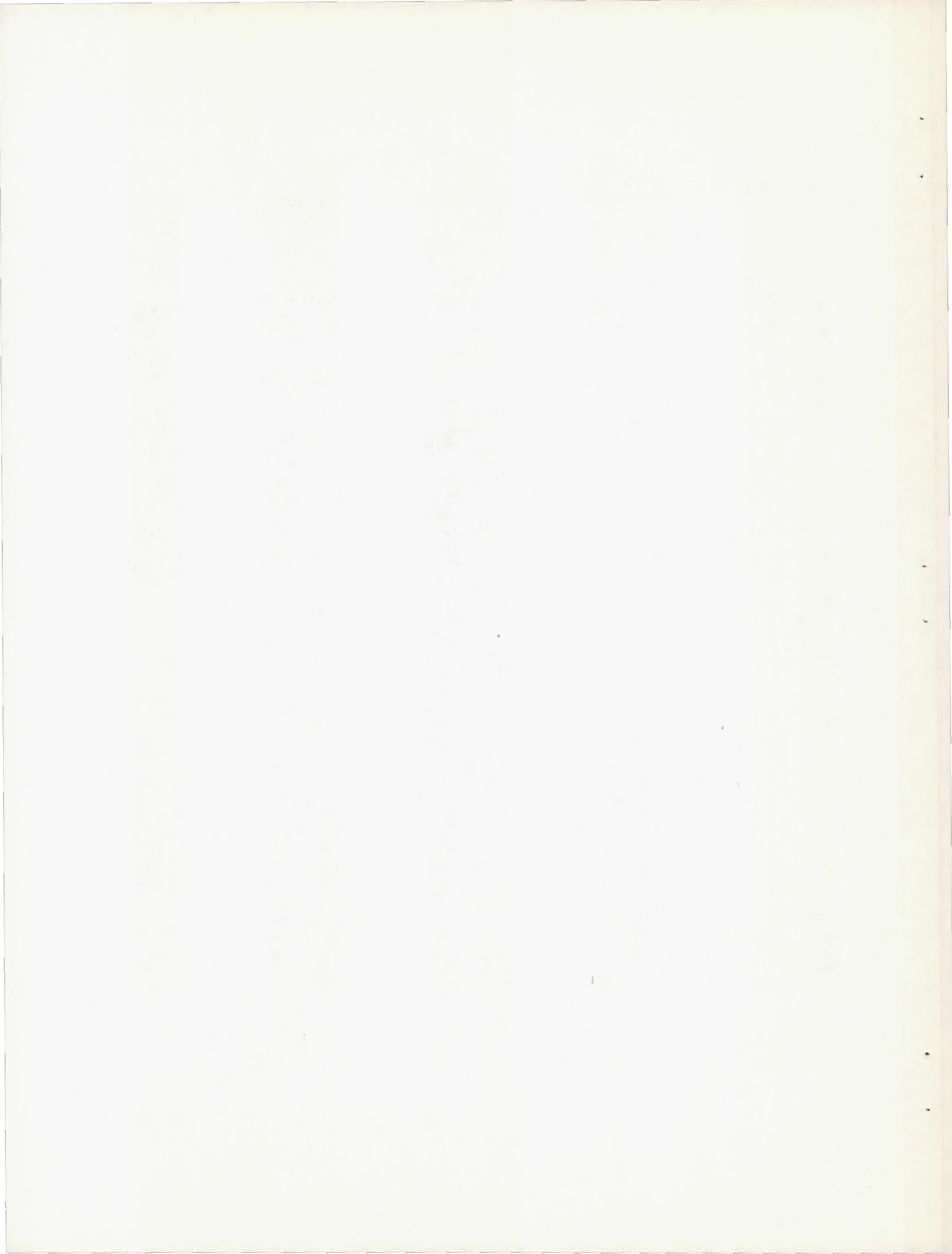

Figure 18.- Typical motion, which is represented by the symbol B in the key to the data, in which the model did not tumble and dived with slightly damped oscillations in pitch until striking the safety net.



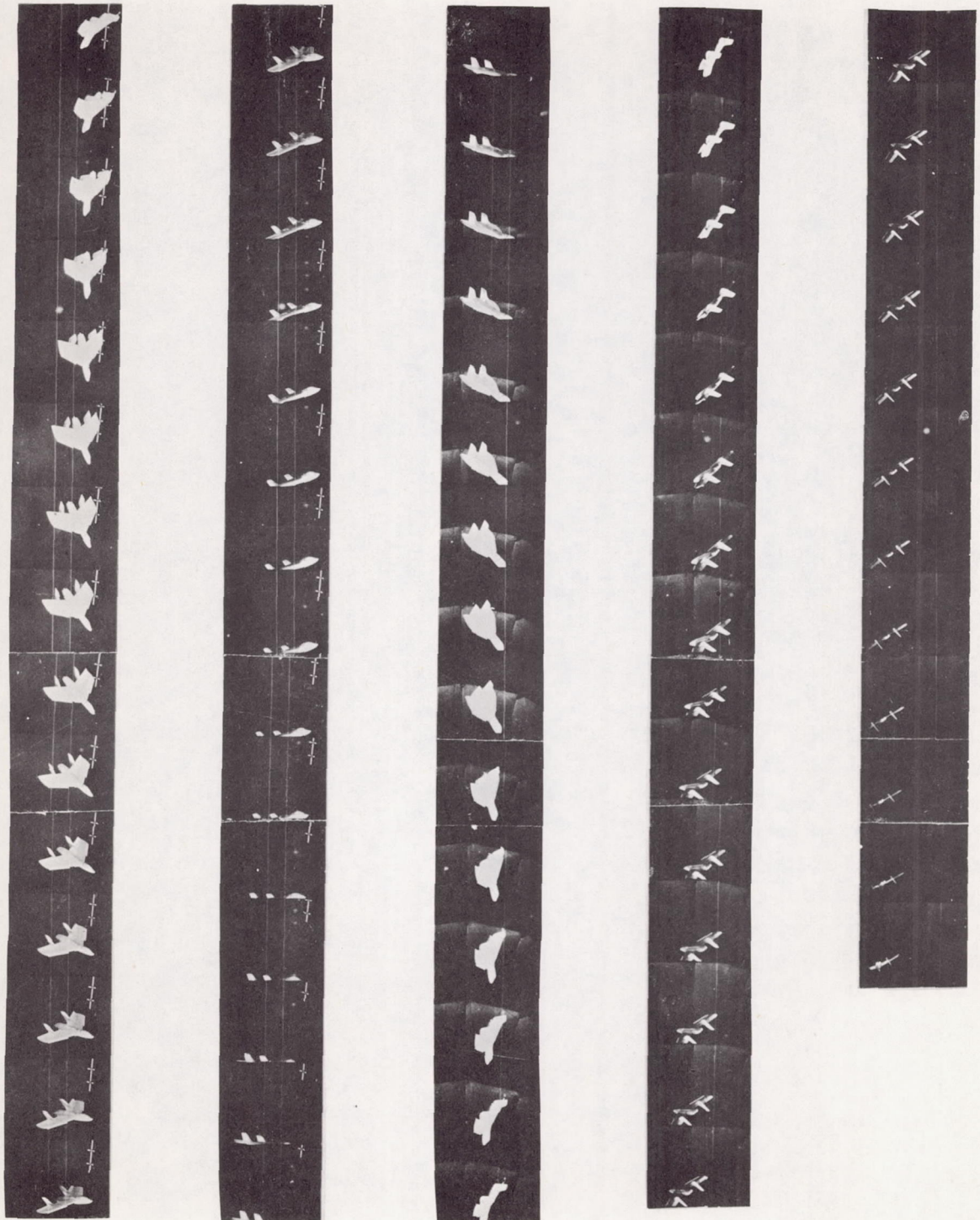

Figure 18.- Concluded.

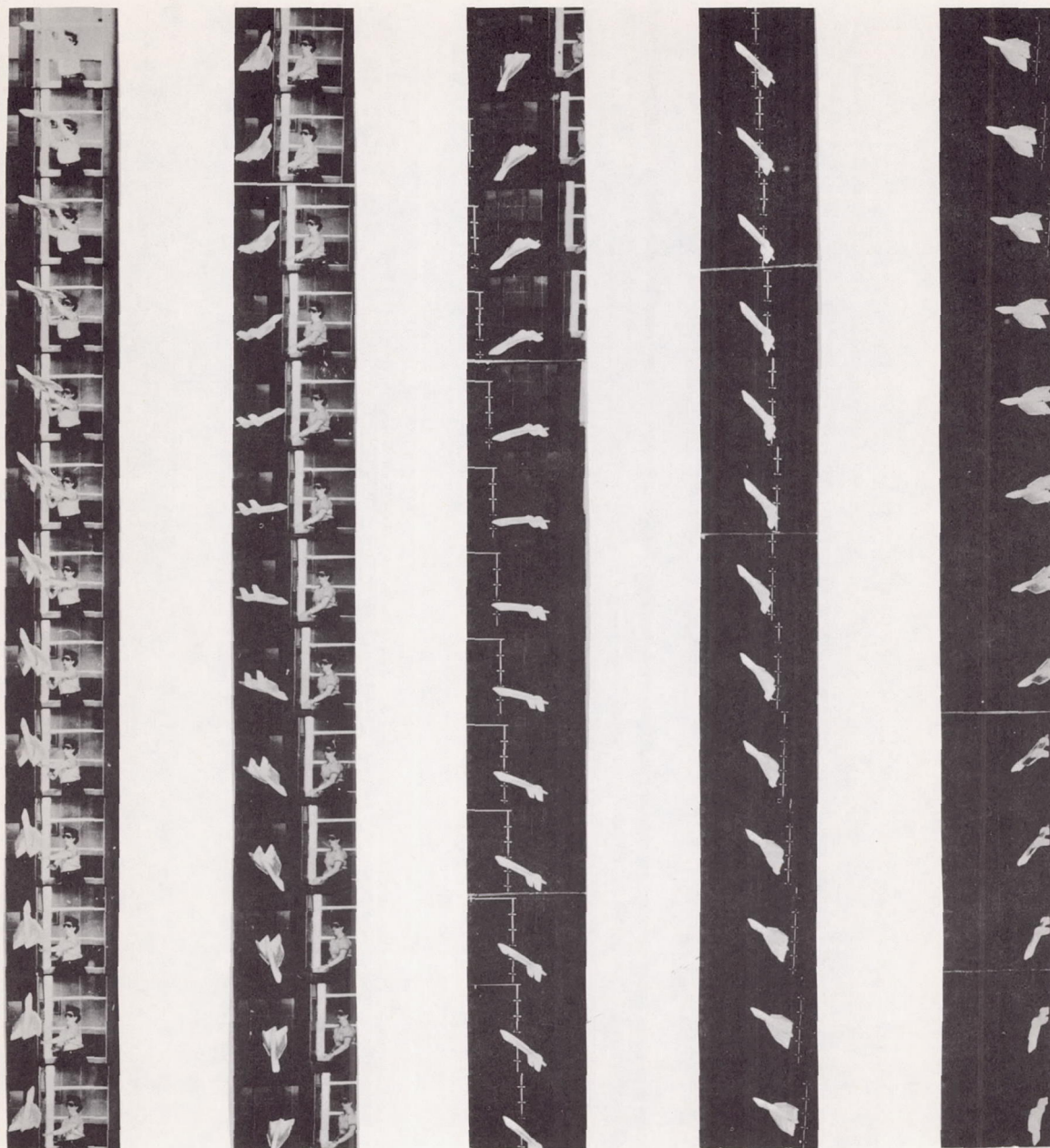
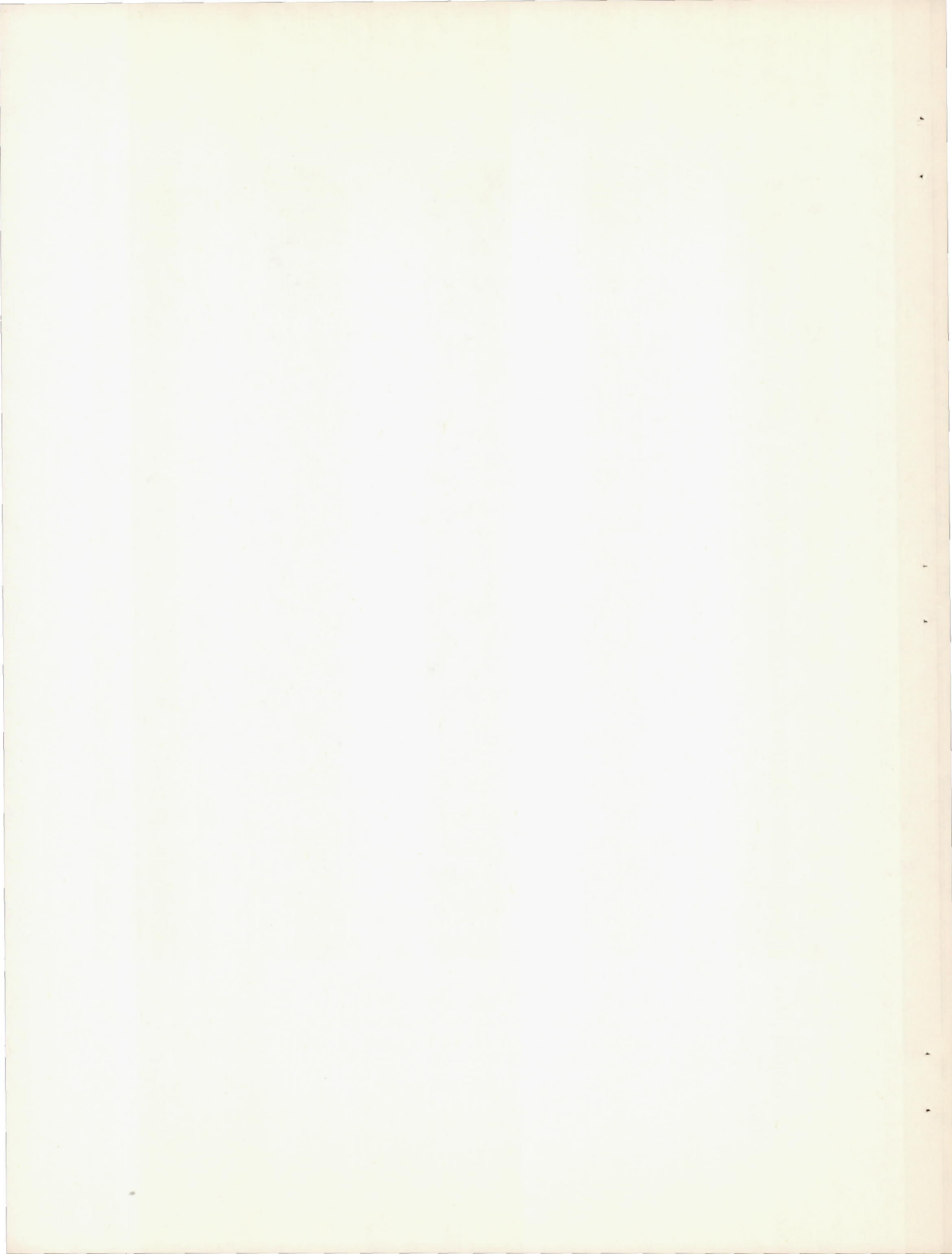

Figure 19.- Typical motion, which is represented by the symbol C in the key to the data, in which the model did not tumble and dived with rapidly damped oscillations in pitch which were completely damped before striking the safety net.



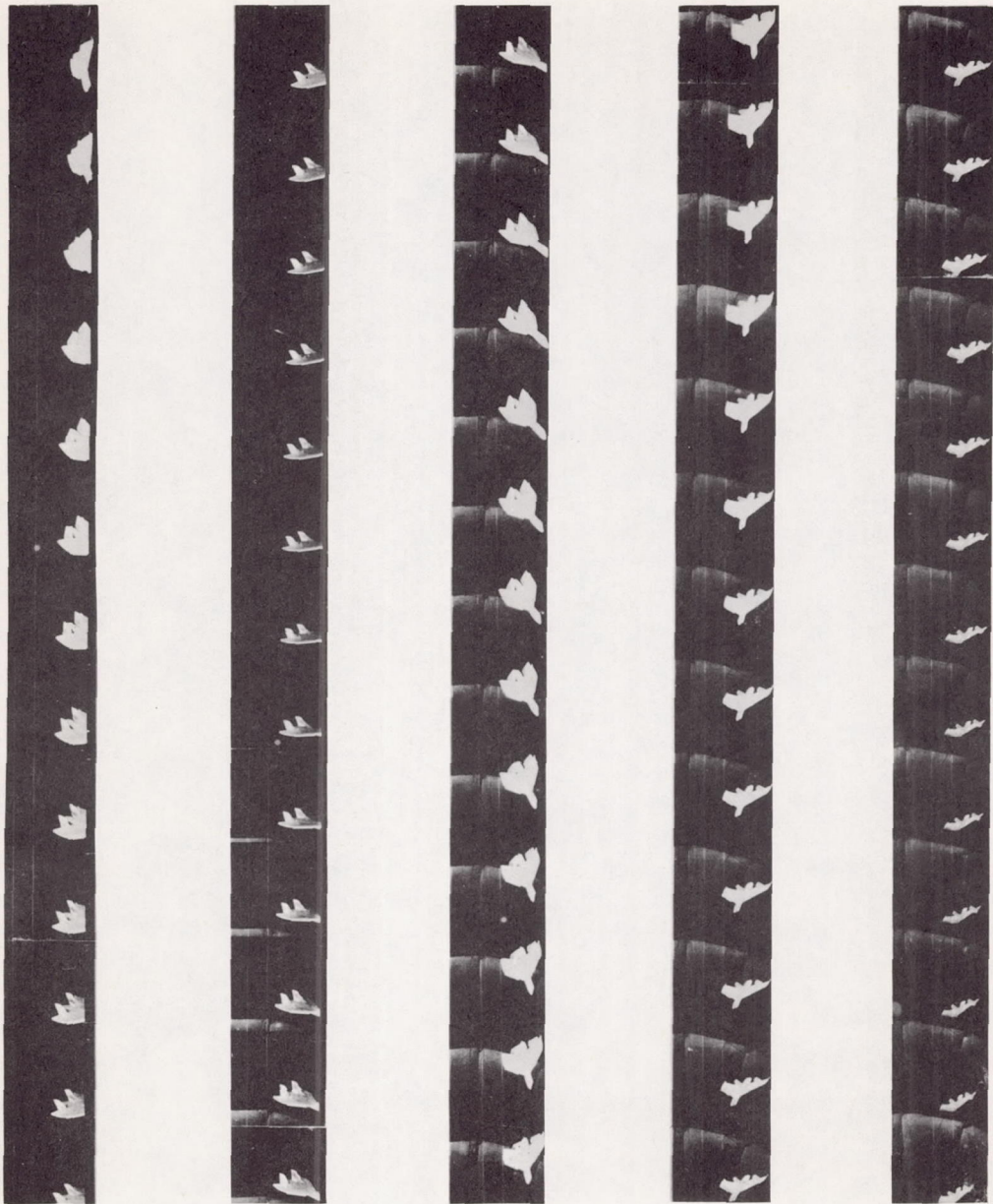

Figure 19.- Concluded.



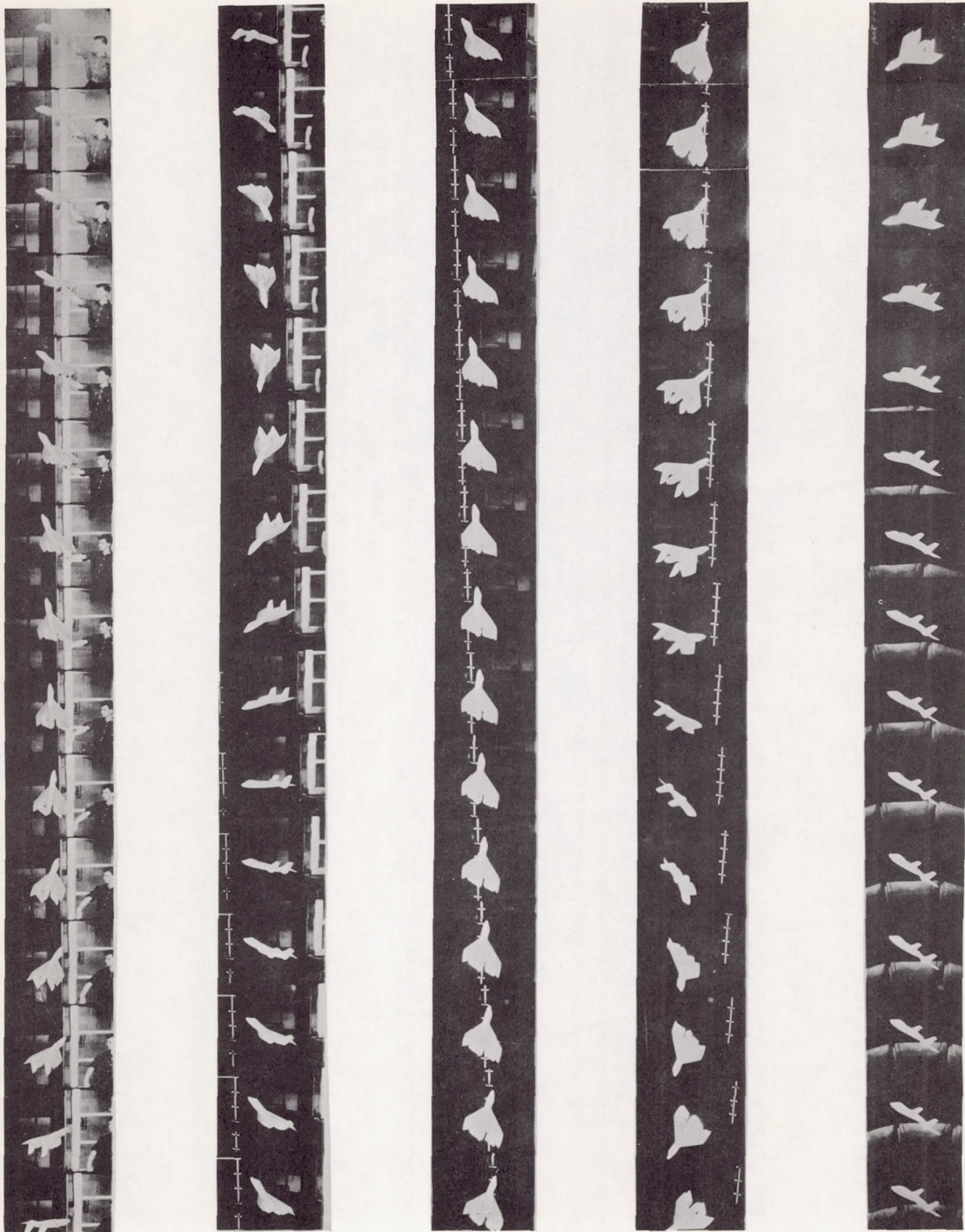
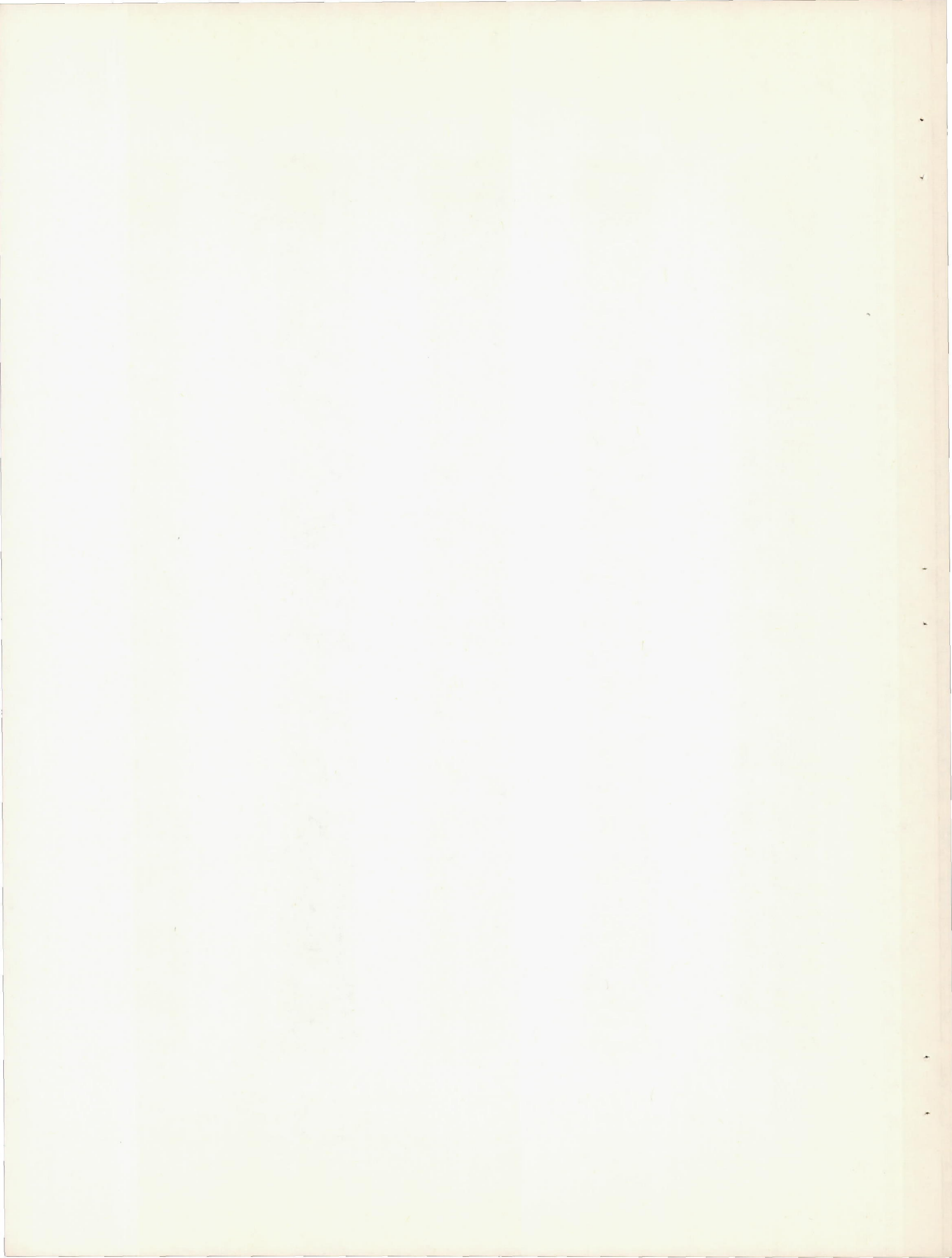

Figure 20.- Typical motion, which is represented by the symbol D in the key to the data, in which the model did not tumble and the oscillations damped almost instantaneously and dived with no oscillations in pitch.



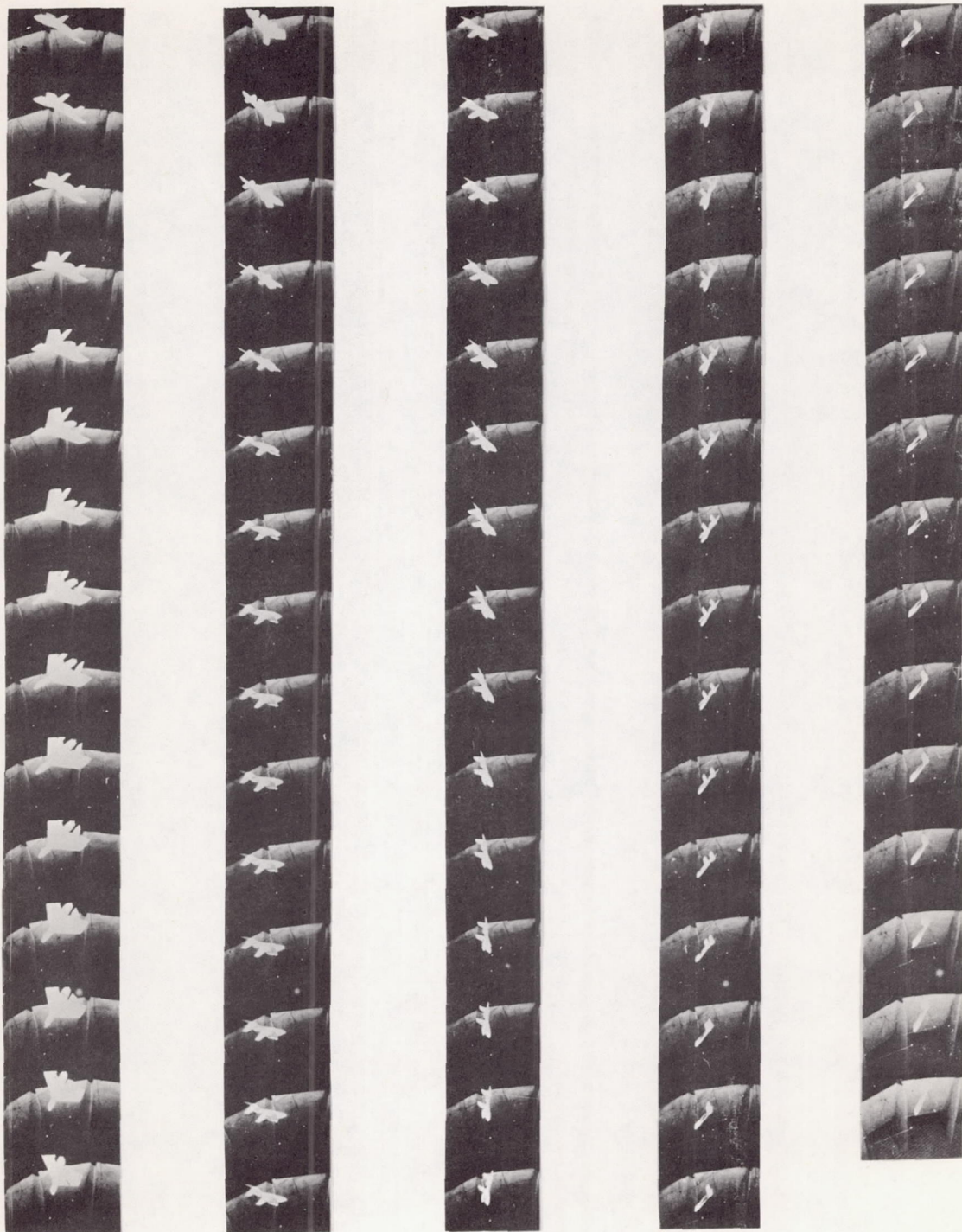

Figure 20.- Concluded.



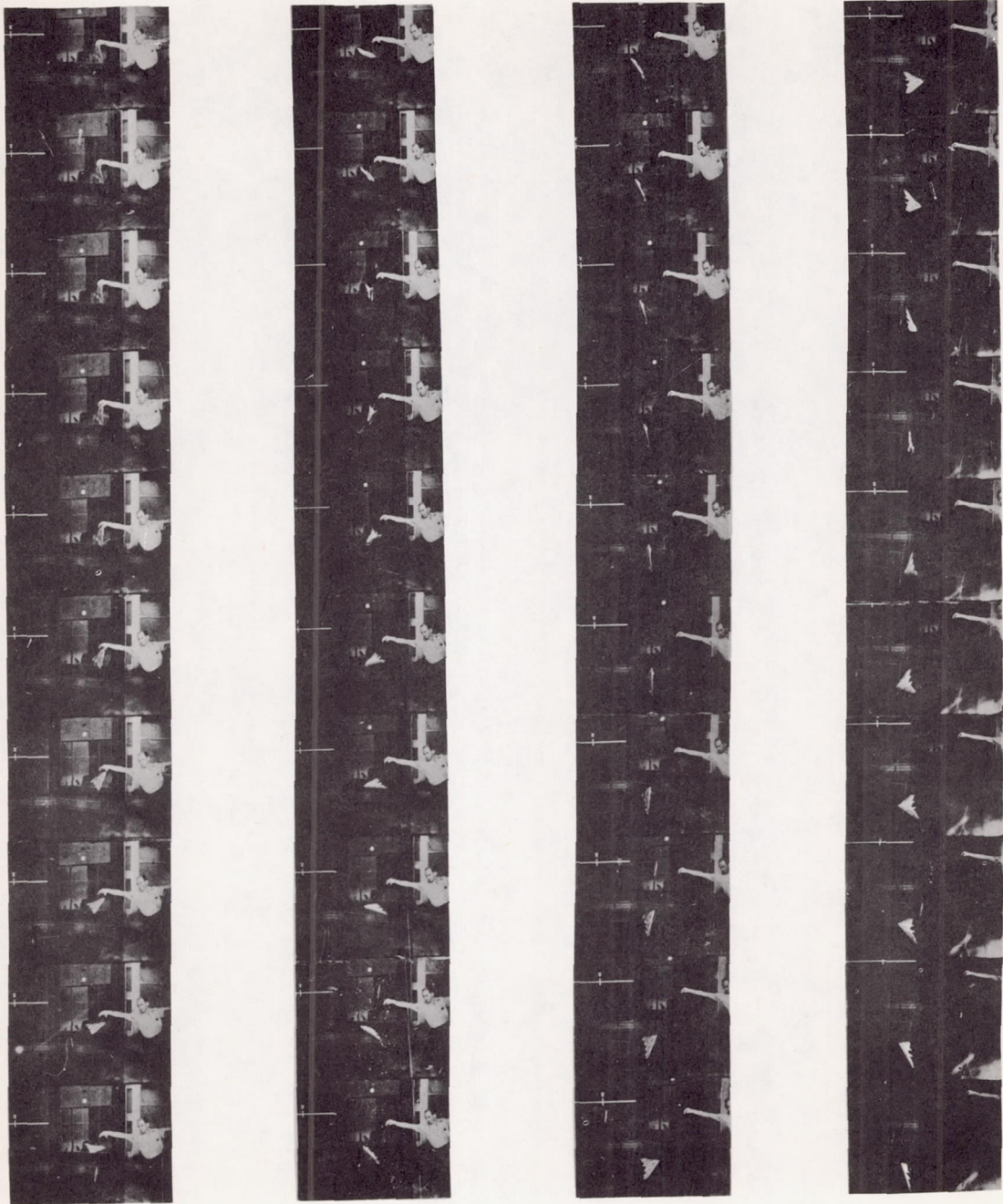

Figure 21.- Typical tumble of model 9 when released from a nose-up attitude. Clean configuration; stick full-back; wheel neutral; scoop rudders and pitch flaps neutral; static margin approximately 0.2 percent. Camera speed, 64 frames per second. Velocity of air stream, approximately 75 feet per second, full scale.

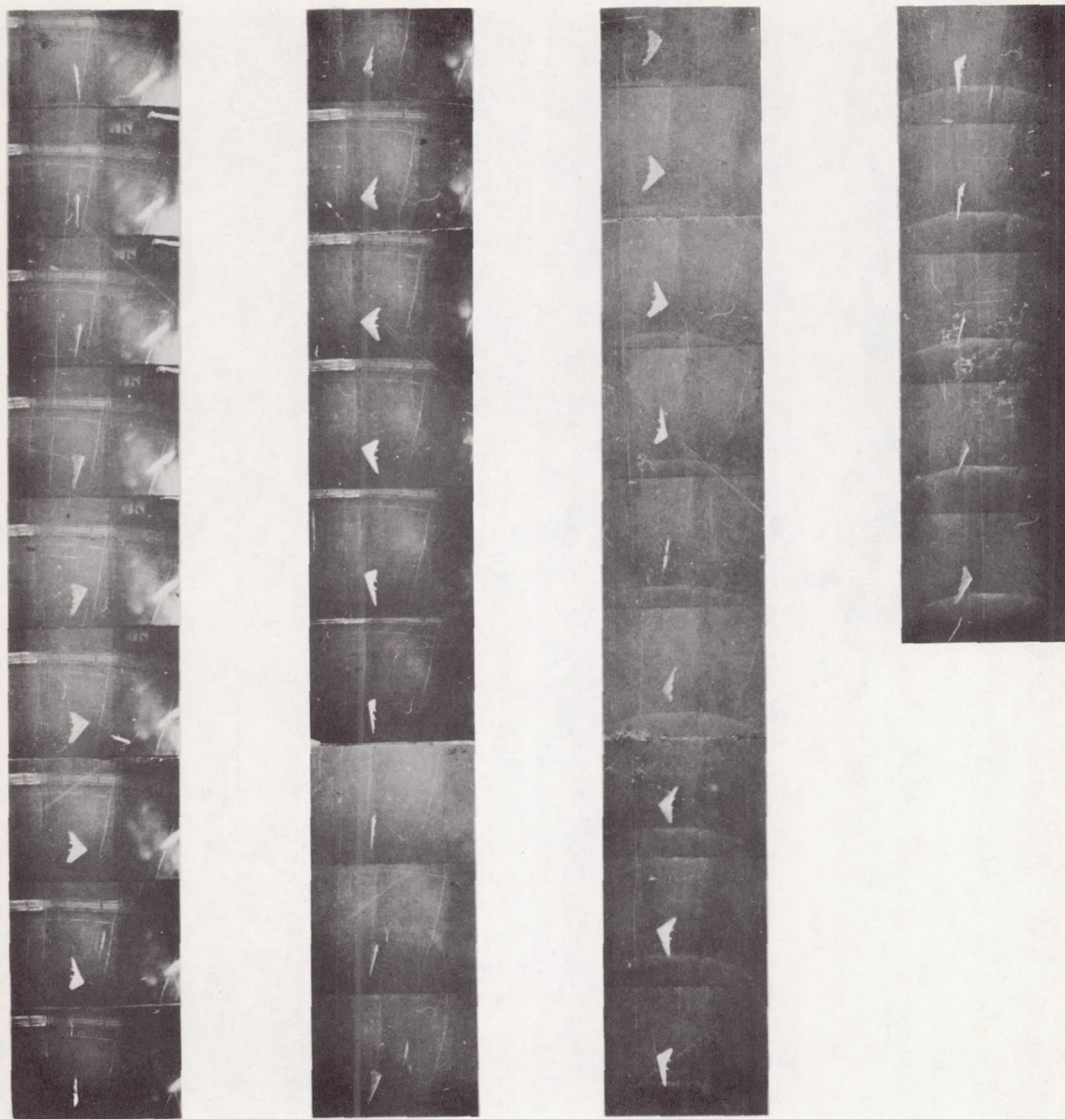
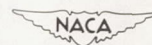

Figure 21.- Concluded.



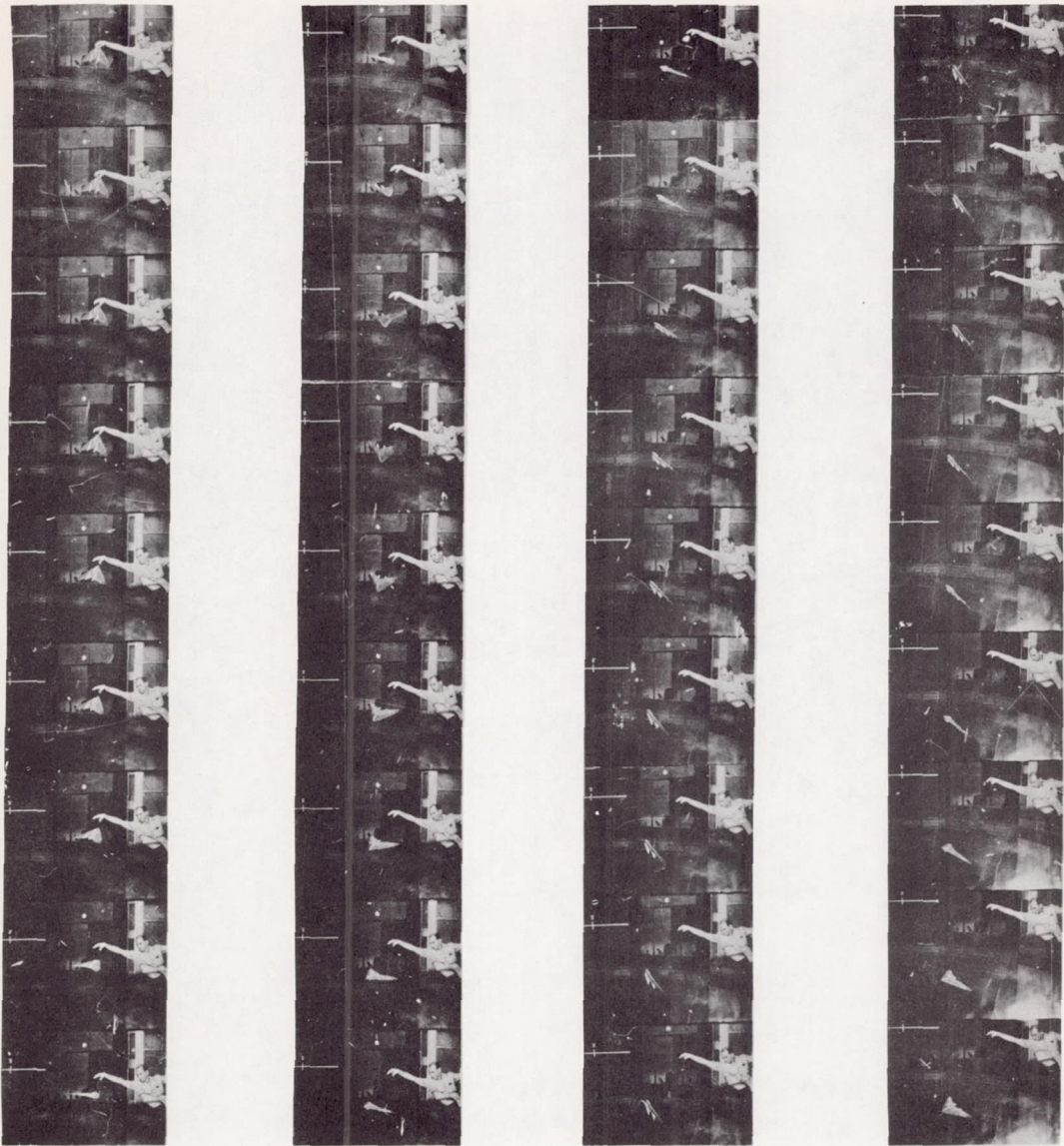

Figure 22.- Typical oscillatory motion of model 9 when released from a nose-up attitude. Clean configuration; stick neutral; wheel neutral; scoop rudders and pitch flaps neutral; static margin approximately 0.2 percent. Camera speed, 64 frames per second. Velocity of air stream, approximately 75 feet per second, full scale.

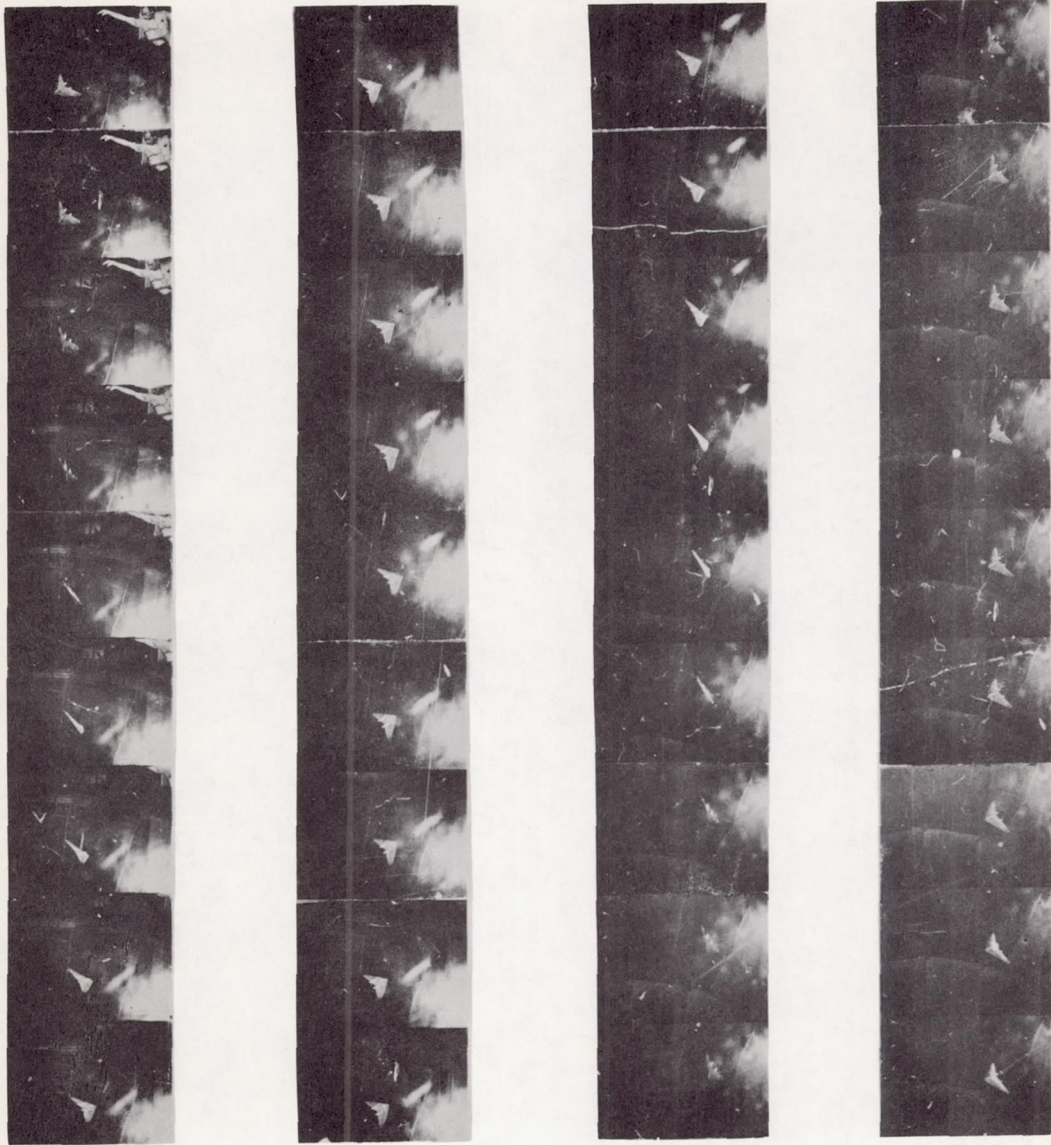
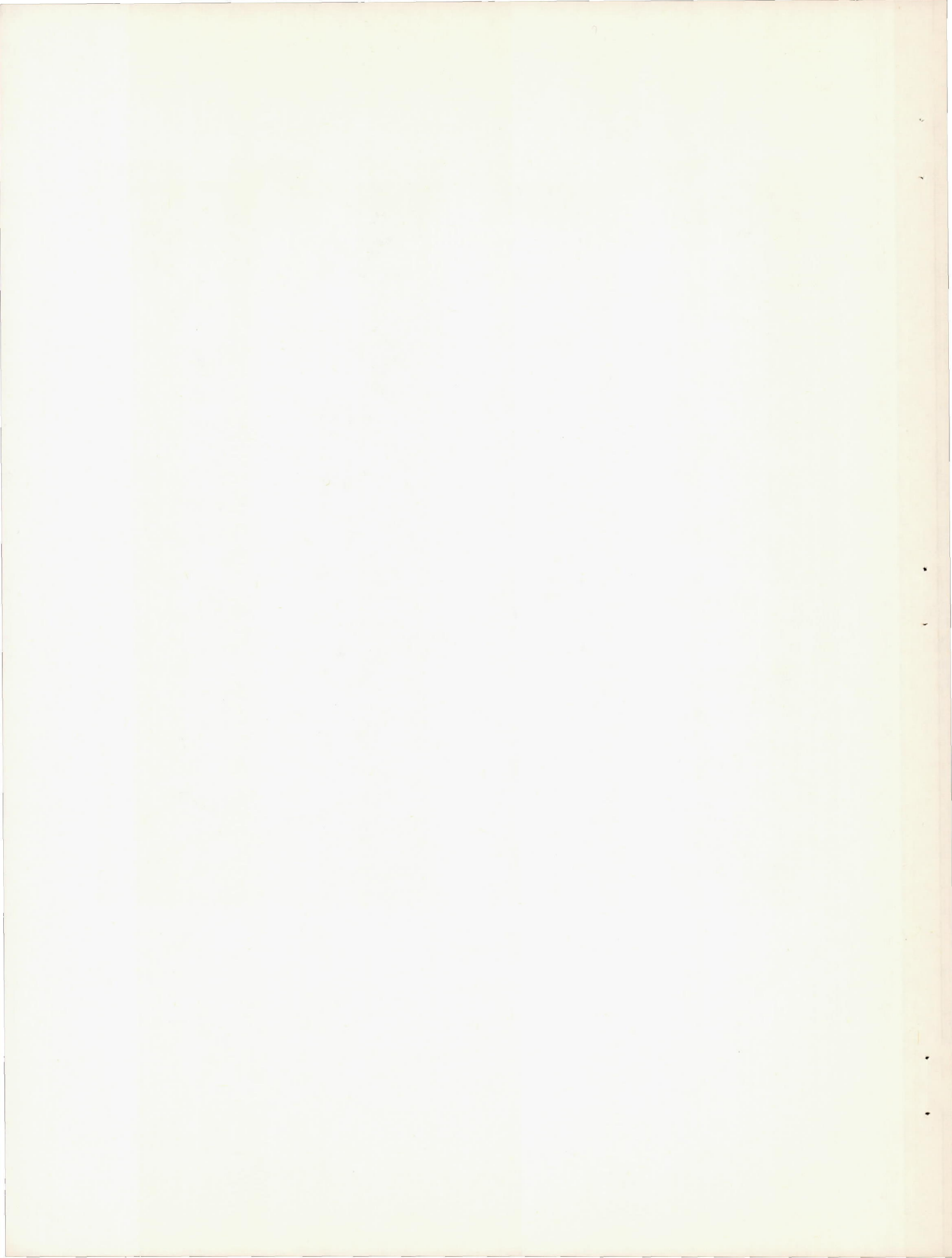

Figure 22.- Concluded.





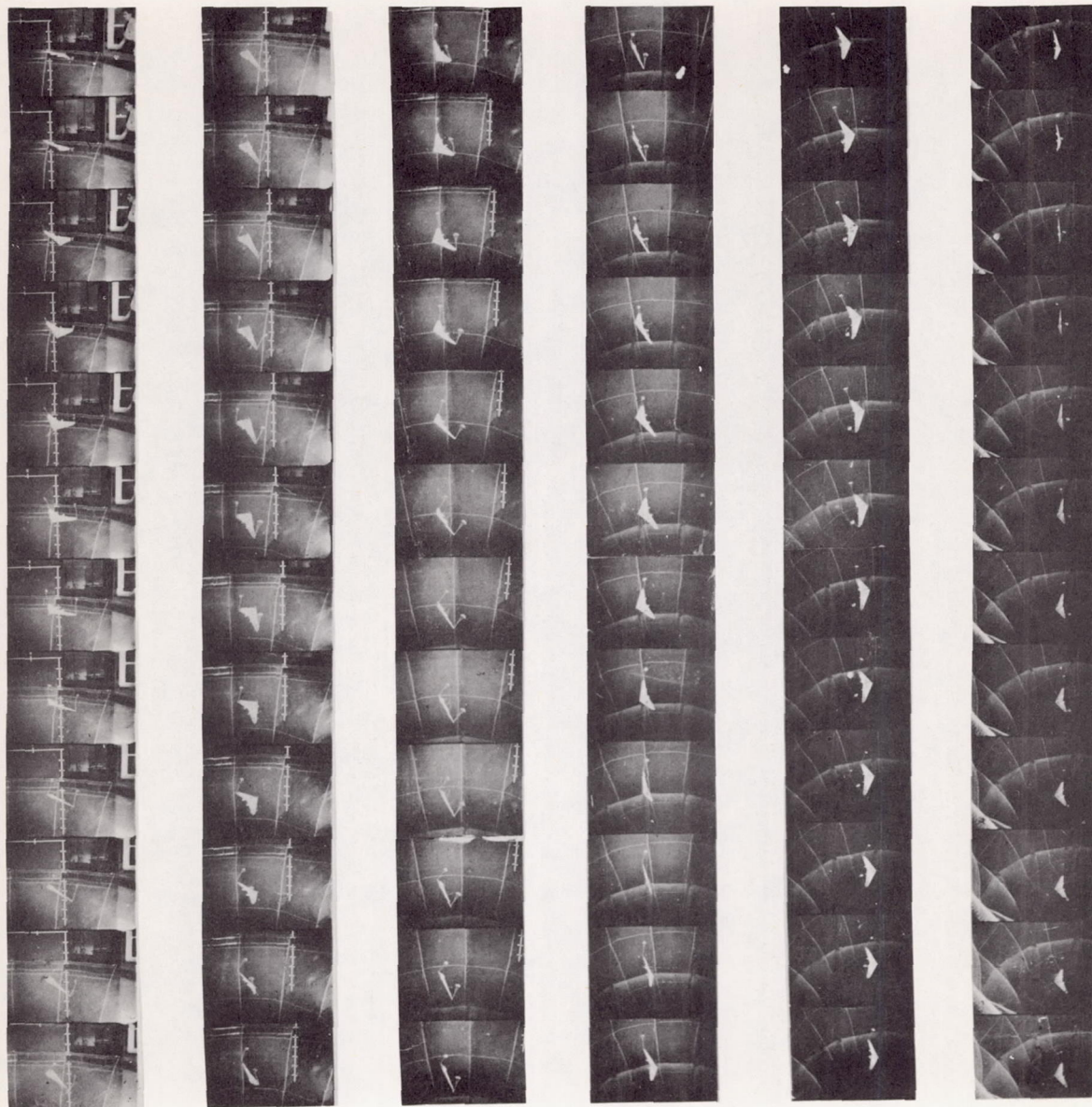

Figure 23.- Typical action of parachutes in producing recovery from an established tumble on model 9. Clean configuration; stick neutral; wheel neutral; rudders neutral; static margin approximately 0.2 percent. Camera speed, 64 frames per second, full scale. Towlines attached to rear portion of wing tips. Parachute diameter, 7 feet, full scale. Parachute drag coefficient, approximately 0.7. Towline length, 10 feet, full scale.