

CONFIDENTIAL

NACA RM A9J06

2353

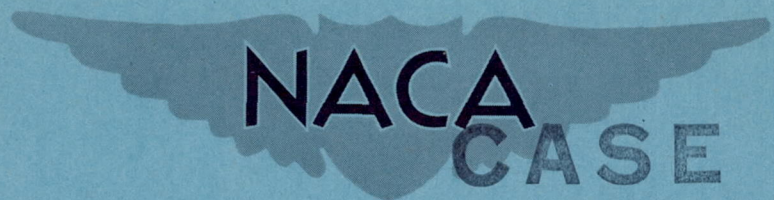

NACA CASE FILE COPY RESEARCH MEMORANDUM

THE EFFECTS OF SCALE AND TEST TECHNIQUE ON THE VALIDITY
OF SMALL-SCALE MEASUREMENTS OF THE AERODYNAMIC
CHARACTERISTICS OF A WING WITH THE LEADING

EDGE SWEEPED BACK 63°

By L. Stewart Rolls

Ames Aeronautical Laboratory
Moffett Field, Calif.

CLASSIFIED DOCUMENT

This document contains classified information affecting the National Defense of the United States within the meaning of the Espionage Act, USC 50:31 and 32. Its transmission or the revelation of its contents in any manner to an unauthorized person is prohibited by law. Information so classified may be imparted only to persons in the military and naval services of the United States, appropriate civilian officers and employees of the Federal Government who have a legitimate interest therein, and to United States citizens of known loyalty and discretion who of necessity must be informed thereof.

NATIONAL ADVISORY COMMITTEE FOR AERONAUTICS

WASHINGTON
December 9, 1949

CLASSIFICATION CHANGED TO UNCLASSIFIED

AUTHORITY: NACA RESEARCH ABSTRACT NO. 121

EFFECTIVE DATE: OCTOBER 14, 1957

CONFIDENTIAL

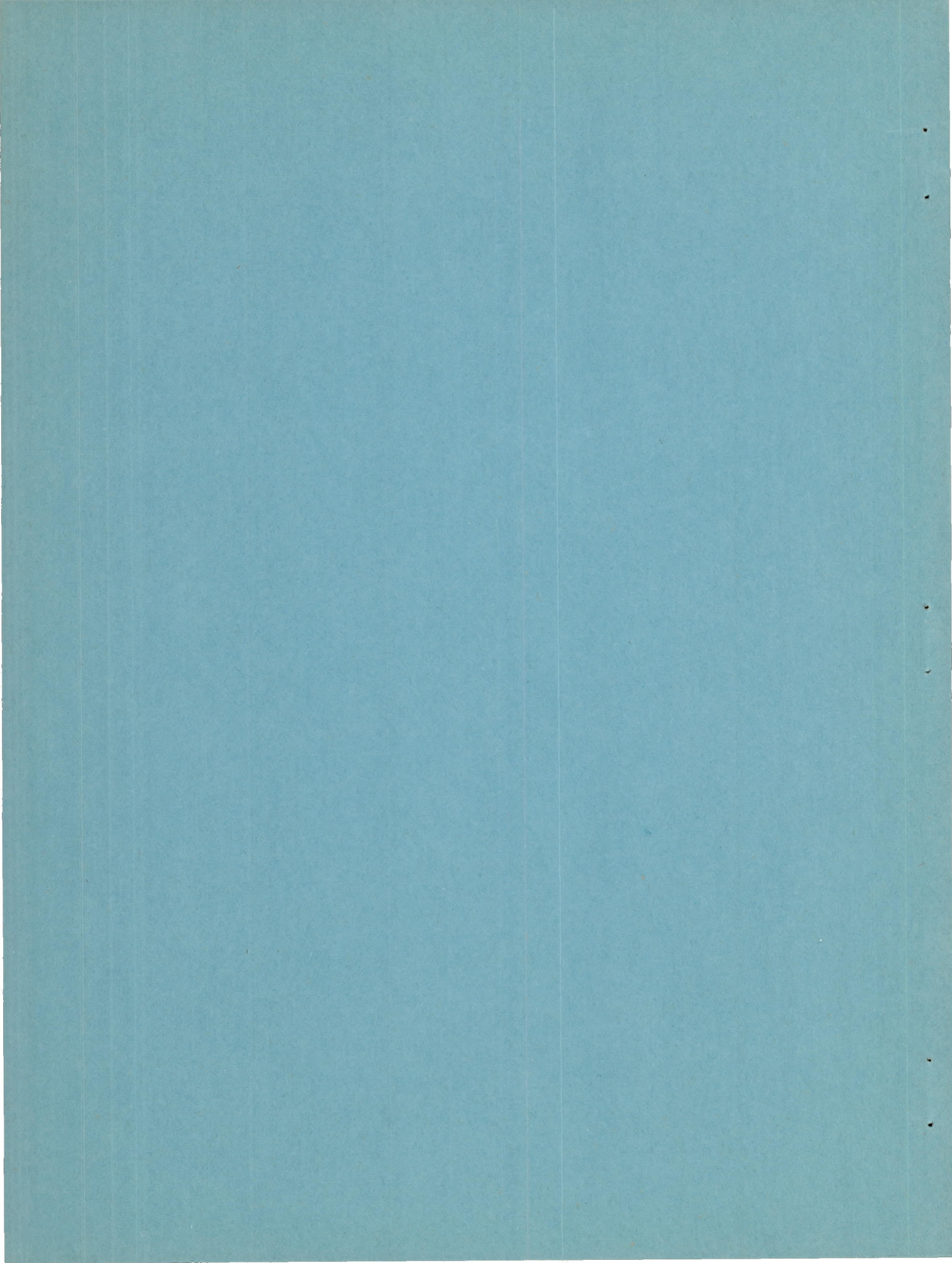

NATIONAL ADVISORY COMMITTEE FOR AERONAUTICS

RESEARCH MEMORANDUMTHE EFFECTS OF SCALE AND TEST TECHNIQUE ON THE VALIDITY OF SMALL-
SCALE MEASUREMENTS OF THE AERODYNAMIC CHARACTERISTICS OF
A WING WITH THE LEADING EDGE SWEEPED BACK 63°

By L. Stewart Rolls

SUMMARY

The lift and pitching-moment characteristics of two wings of the same plan form (aspect ratio 3.5, taper ratio 0.25, and leading-edge sweep angle 63°) have been measured by the NACA wing-flow method in the Mach number range 0.52 to 1.11 and Reynolds number range 0.39 million to 0.81 million. One wing had a symmetrical airfoil section and no twist, while the other was cambered and twisted to support a uniform load distribution at a lift coefficient of 0.25 at a Mach number of 1.5.

The data are compared with the results from tests of similar models in the Ames 12-foot pressure wind tunnel at Reynolds numbers of approximately 2 million. The comparison shows appreciable discrepancy in the measured pitching-moment characteristics. Changes in the model configuration and test procedure were investigated, but no conclusive explanation of the discrepancy was developed. It is concluded that any attempt to determine the pitching-moment characteristics of highly swept-back wings is inadvisable at such small scale and at such low Reynolds numbers with semispan models.

INTRODUCTION

As a continuation of a general investigation of the aerodynamic characteristics of a wing with the leading edge swept back 63° , tests were conducted by the wing-flow method in order to obtain data bracketing a Mach number of 1.0. One of the models for the wing-flow tests had a symmetrical airfoil and no twist, while the other model was cambered and twisted to support a uniform load distribution at a lift coefficient of 0.25 at a Mach number of 1.5. The results of previous tests of the symmetrical wing are presented in references 1, 2, and 3, while the results of tests of the cambered and twisted wing are contained in references 4 and 5.

Since the pitching-moment data showed wide discrepancies when compared to data from tests at higher Reynolds numbers in the Ames 12-foot pressure wind tunnel, an attempt was made to isolate the cause of these discrepancies.

SYMBOLS

- C_L lift coefficient $\left(\frac{\text{lift}}{qS'} \right)$
- C_m pitching-moment coefficient measured about 25-percent \bar{c}
 $\left(\frac{\text{pitching moment}}{qS'\bar{c}} \right)$
- M Mach number $\left(\frac{V}{a} \right)$
- R Reynolds number $\left(\frac{\rho V \bar{c}}{\mu} \right)$
- S' wing area of the semispan model, square feet
- V airspeed, feet per second
- a speed of sound, feet per second
- b wing span, perpendicular to plane of symmetry, feet
- c local chord, parallel to plane of symmetry, feet
- \bar{c} mean aerodynamic chord $\left(\frac{\int_0^{b/2} c^2 dy}{\int_0^{b/2} c dy} \right)$, feet
- q dynamic pressure $\left(\frac{1}{2} \rho V^2 \right)$, pounds per square foot
- y spanwise distance, feet

y_c	distance between camber line and chord line, feet
α	angle of attack, degrees
α_t	angle of twist, positive for washin, degrees
μ	air viscosity, slugs per foot-second
ρ	mass density of air, slugs per cubic foot

MODELS

Dimensions of the models used in this investigation are presented in figures 1 and 2. The two wings were made of steel and had identical plan forms: an aspect ratio of 3.5, a taper ratio of 0.25, and 63° of leading-edge sweepback. The untwisted wing was composed of NACA 64A006 airfoil sections in the streamwise direction. The cambered and twisted wing had the NACA 64A005 thickness distribution in combination with a = 1 mean camber lines. Distribution of wing twist and spanwise camber variation are presented in figure 2.

In addition to the wing-alone configuration, the untwisted symmetrical wing was tested alternately with a chordwise fence fitted near the wing root parallel to the stream direction, and with a half-fuselage of circular cross section having a fineness ratio of 6-1/4. These modifications are illustrated in figure 3.

METHODS AND EQUIPMENT

The majority of the data was obtained by placing the semispan models in a region of accelerated air flow over a special built-up test station on an airplane wing. The model was mounted on a three-component recording balance which was rotated to vary the angle of attack. A general view of the test station with the model installed is shown in figure 4. For certain of the tests the balance was installed in the side wall of the Ames 1- by 3-1/2-foot high-speed wind tunnel as illustrated in figure 5.

A detailed description of the wing-flow test station and the force-measuring equipment used in this investigation is presented in reference 6, including discussions of the horizontal and vertical Mach number gradients, boundary-layer characteristics, and the three-component balance. The ratio of test-station boundary-layer-displacement thickness to model span for the wing-flow tests was 0.0075, nearly the same as

the value of 0.0083 measured in the Ames 12-foot pressure wind tunnel during the tests reported in reference 1. The ratio for the wing-flow model mounted on the side of the Ames 1- by 3-1/2-foot wind tunnel was 0.0330.

TESTS

The wing-flow data were recorded in the form of time histories of an oscillation of the model from -5° to $+8^\circ$ angle of attack at various constant Mach numbers from 0.52 to 1.11. The corresponding Reynolds numbers are presented in figure 6. Tests were conducted on the following configurations:

1. Symmetrical untwisted wing
2. Cambered and twisted wing
3. Symmetrical untwisted wing plus fuselage
4. Symmetrical untwisted wing plus chordwise boundary-layer fence

In addition, the wing-flow balance was mounted on the wall of the Ames 1- by 3-1/2-foot high-speed wind tunnel so that the top of the balance was flush with the inside of the tunnel wall. The Mach number range in these tests was 0.75 to 0.92, with an approximate range of Reynolds number of 0.69 million to 0.78 million. Tests were conducted on the symmetrical untwisted wing at constant Mach numbers, both by oscillating the model over the angle-of-attack range and by recording at various fixed angles of attack.

PRECISION

The precision of the physical measurements made during these tests has been evaluated as described in reference 6. The following table shows representative values of the test data and the physical uncertainty in each, at the lowest and highest Mach numbers at a lift coefficient of 0.30:

<u>Quantity</u>	<u>M = 0.52</u>	<u>M = 1.11</u>
Mach number M	0.52 \pm 0.01	1.11 \pm 0.02
Angle of attack α , degrees	7.8 \pm 0.4	6.8 \pm 0.4
Lift coefficient C_L	0.3 \pm 0.01	0.3 \pm 0.006
Pitching-moment coefficient $C_{m_{0.25\bar{c}}}$	0.003 \pm 0.0009	0.002 \pm 0.0001

RESULTS AND DISCUSSION

Basic Data

The typical variations of angle of attack and pitching-moment coefficient with lift coefficient are illustrated in figure 7 by the basic test data for the symmetrical untwisted wing. These same curves for all the test configurations were equally linear and indicated no obvious irregularities.

Comparison with Larger-Scale Tests

The characteristics of both the symmetrical wing alone and the cambered and twisted wing alone are summarized in figure 8, which shows the lift-curve slopes and the locations of the aerodynamic center as a function of Mach number. Also included in figure 8 are corresponding data up to 0.925 Mach number and at a Reynolds number of approximately 2 million from tests in the Ames 12-foot pressure wind tunnel (references 1 and 4). The comparison for the symmetrical wings is based upon tests using the same type of model and mounting; that is, semispan model on a flat reflection plate. In the case of the cambered and twisted wings the wind-tunnel model was full span and sting mounted;¹ whereas the wing-flow model again was semispan.

The comparison in figure 8 between wing-flow and wind-tunnel results for the symmetrical wing indicates fair agreement for the variation of lift-curve slope with Mach number up to the limit of the wind-tunnel tests. The pitching-moment-curve slopes, however, reveal a considerable discrepancy. The aerodynamic-center location as determined from the wing-flow tests would be about 18 percent of the mean aerodynamic chord forward of the position indicated by the wind-tunnel tests. The comparison for the cambered and twisted wing shows the wing-flow model had a lower lift-curve slope which decreased rather than increased with increasing Mach number. The pitching-moment characteristics show the same sizable differences, as in the case of the symmetrical wings.

Additional Tests

The noted discrepancies cast serious doubt on the validity of the wing-flow data on the test wings, particularly in regard to the pitching-moment characteristics.² Since quite satisfactory correlation between

¹The sting mount necessitated the addition of a fuselage; thus these results are for the wing-fuselage combination.

²The effects of aeroelasticity were considered but found to be within the experimental scatter of the measurements.

wing-flow data and data at higher Reynolds numbers from the Ames 12-foot pressure wind tunnel has been obtained in the case of a wing with an unswept plan form (reference 6) and in unreported tests of a triangular wing, it appears that the discrepancy on the test wings might be attributed to the extremely high sweep and/or the lower than ordinary Reynolds number of the tests which the limitations on the model size made necessary. One of the more likely factors was thought to be a boundary-layer drain spanwise along the wing which would be likely to be present on the test wings in view of their high sweepback and which would be aggravated if the low Reynolds number of the tests caused separation (and a resulting "tunnel" along which the boundary layer from the wing-flow test station could drain). Another possible source of error could have been the spanwise velocity gradients which existed on the wing-flow test station which, if they caused a change in spanwise loading, would, on a wing of such high sweep, show up as an appreciable longitudinal shift of the aerodynamic center. In an attempt to determine which of the foregoing factors might contribute to the anomalous results, the supplementary tests outlined below were performed on the symmetrical untwisted wing.

To determine the effect of the spanwise velocity gradient which existed at the wing-flow station, the test setup was duplicated on the side wall of the Ames 1- by 3-1/2-foot high-speed wind tunnel. The entire wing-flow balance was mounted on the outside of the tunnel, with the turntable flush with the inside of the tunnel wall and the semispan wing model projecting into the tunnel air stream. This gave a test configuration which duplicated in all essential respects the wing-flow setup with the exceptions that the spanwise velocity gradient was negligible and the ratio of boundary-layer-displacement thickness to model span was considerably larger. The results summarized in figure 9 show negligible change for pitching-moment-curve slope, checking the wing-flow data within the measurement accuracy limitations. The discrepancy therefore does not appear to be caused by spanwise velocity gradient.

While the model and balance were mounted in the tunnel, the effect of oscillation of the model on the test data was also determined. Tests were conducted at constant Mach number both by continuous recording of forces and moments while oscillating the model over the angle-of-attack range and by recording at various fixed angles of attack. There was no observable difference between the results of these two techniques.

To either eliminate or change any possible spanwise boundary-layer drain along the test wing, two model modifications were tested by the wing-flow technique. The first was the addition of a fuselage, which it was reasoned would place the model wing root well out of the test station boundary layer and thus reduce the tendency for spanwise drain. (See fig. 3(b).) The other modification tested was a boundary-layer fence placed 0.4 inch above the test-station surface where it would obstruct the spanwise drain of the boundary layer along the span of the model

wing. (See fig. 3(a).) Neither of these modifications resulted in significant changes in the pitching-moment data (fig. 9) so that no confirmation of the hypothesis as to boundary-layer drain was obtained.

The fact that low Reynolds number alone is not sufficient to account for the doubtful pitching-moment results is deducible from the fact that results of Ames 1- by 3-1/2-foot high-speed wind-tunnel tests (reference 3) of a full-span model of the symmetrical untwisted wing gave an extreme aft position of the aerodynamic center rather than an extreme forward position as in the wing-flow tests. The comparison of these various tests is presented in the following table:

Mach number	Wing-flow method		12-foot pressure wind tunnel		1- by 3-1/2-foot high-speed wind tunnel	
	Aerodynamic center ($\% \bar{c}$)	Reynolds number	Aerodynamic center ($\% \bar{c}$)	Reynolds number	Aerodynamic center ($\% \bar{c}$)	Reynolds number
0.6	25	0.55×10^6	42	2.35×10^6	54	0.42×10^6
.9	25.5	$.73 \times 10^6$	44	2.35×10^6	60	$.51 \times 10^6$
1.1	26	$.81 \times 10^6$	-	- - - -	74	$.53 \times 10^6$

That the discrepancies cannot be attributed to the semispan mounting alone is deducible from the fact that the 12-foot pressure wind tunnel has obtained good correlation on results of semispan and full-span 63° swept wings at a Reynolds number of the order of 2 million. Further verification of the semispan testing technique (at high Reynolds number) is contained in reference 7, where a comparison is presented of the data obtained from both semispan and full-span models of a 40° swept-back wing.

In view of the foregoing discussion no substantiated explanation can be presented of the cause of the discrepancy between the wing-flow pitching-moment characteristics and those presented in references 1 and 4. Therefore it can only be concluded that the wing-flow data on a wing of this plan form cannot be relied upon even qualitatively as an indication of trends.

CONCLUDING REMARKS

The data presented in this report indicate considerable discrepancy in the pitching-moment characteristics for a highly swept and tapered plan form as measured by the wing-flow method and by the larger-scale Ames 12-foot pressure wind tunnel. Attempts to account for the differences by modifying the wing-flow model configuration and technique were inconclusive.

It is therefore considered undesirable to attempt to determine the pitching-moment characteristics of highly swept-back wings at such small scale and at such low Reynolds number in the range of Mach numbers covered by this investigation. Similar conclusions for both the pitching moment and the drag due to lift characteristics have been expressed in NACA RM A9E09, 1949, resulting from an investigation of a model of a wing-body combination using the same plan form and tested at a similar scale in the Ames 1- by 3-1/2-foot high-speed wind tunnel.

Ames Aeronautical Laboratory,
National Advisory Committee for Aeronautics,
Moffett Field, Calif.

REFERENCES

1. Reynolds, Robert M., and Smith, Donald W.: Aerodynamic Study of a Wing-Fuselage Combination Employing a Wing Swept Back 63° .— Subsonic Mach and Reynolds Number Effects on the Characteristics of the Wing and on the Effectiveness of an Elevon. NACA RM A8D20, 1948.
2. Madden, Robert T.: Aerodynamic Study of a Wing-Fuselage Combination Employing a Wing Swept Back 63° .— Characteristics at a Mach Number of 1.53 Including Effect of Small Variations of Sweep. NACA RM A8J04, 1949.
3. Mas, Newton A.: Aerodynamic Study of a Wing-Fuselage Combination Employing a Wing Swept Back 63° .— Characteristics for Symmetrical Wing Sections at High Subsonic and Moderate Supersonic Mach Numbers. NACA RM A9E09, 1949.
4. Jones, J. Lloyd, and Demele, Fred A.: Aerodynamic Study of a Wing-Fuselage Combination Employing a Wing Swept Back 63° .— Characteristics Throughout the Subsonic Speed Range with the Wing Cambered and Twisted for a Uniform Load at a Lift Coefficient of 0.25. NACA RM A9D25, 1949.
5. Madden, Robert T.: Aerodynamic Study of a Wing-Fuselage Combination Employing a Wing Swept Back 63° .— Investigation at a Mach Number of 1.53 to Determine the Effects of Cambering and Twisting the Wing for Uniform Load at a Lift Coefficient of 0.25. NACA RM A9C07, 1949.
6. Rathert, George A., Jr., Hanson, Carl M., and Rolls, L. Stewart: Investigation of a Thin Straight Wing of Aspect Ratio 4 by the NACA Wing-Flow Method.— Lift and Pitching-Moment Characteristics of the Wing Alone. NACA RM A8L20, 1949.

7. Cahill, Jones F.: Comparison of Semispan Data Obtained in the Langley Two-Dimensional Low-Turbulence Pressure Tunnel and Full-Span Data Obtained in the Langley 19-Foot Pressure Tunnel for a Wing with 40° Sweepback of the 0.27-Chord Line. NACA RM L9B25a, 1949.

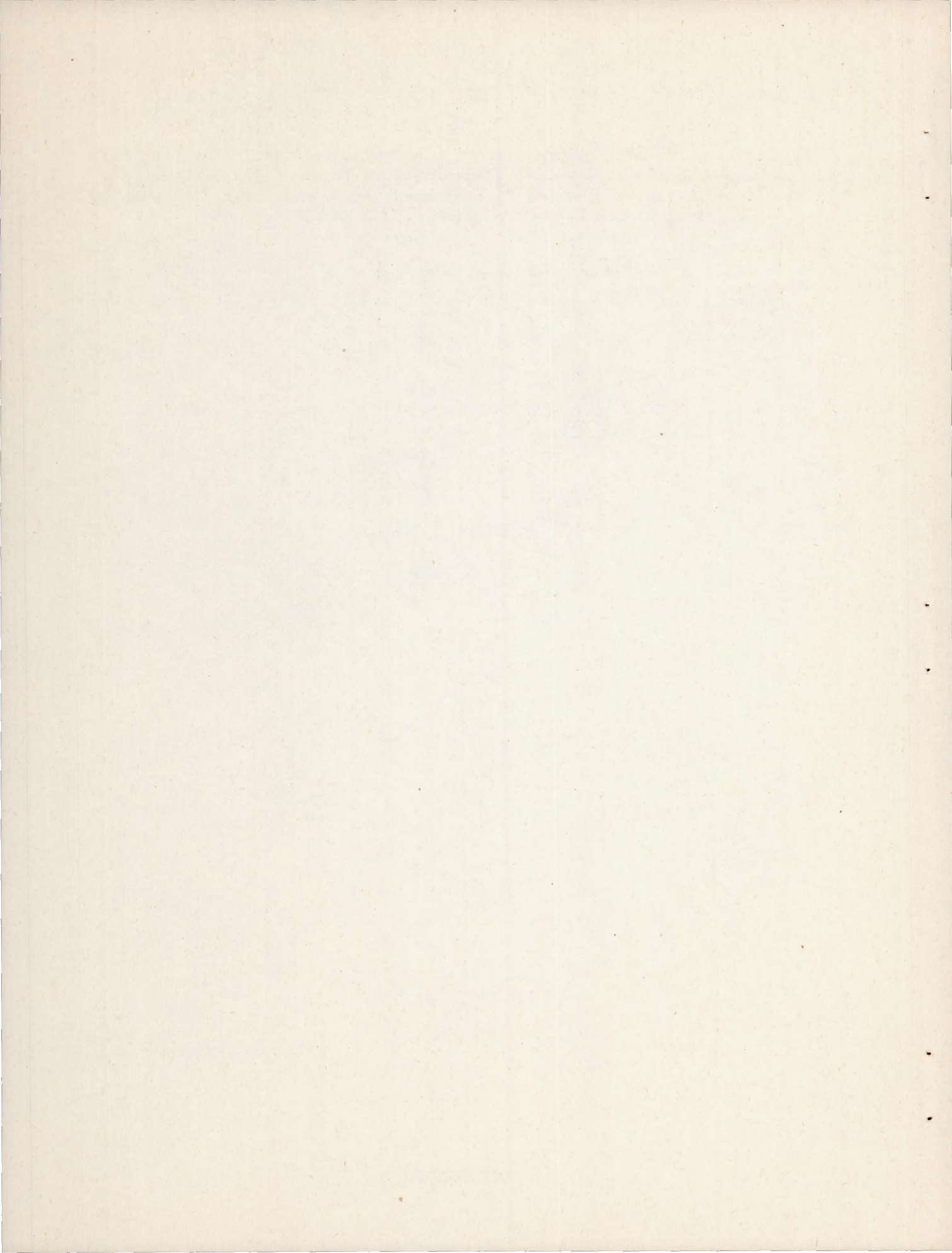

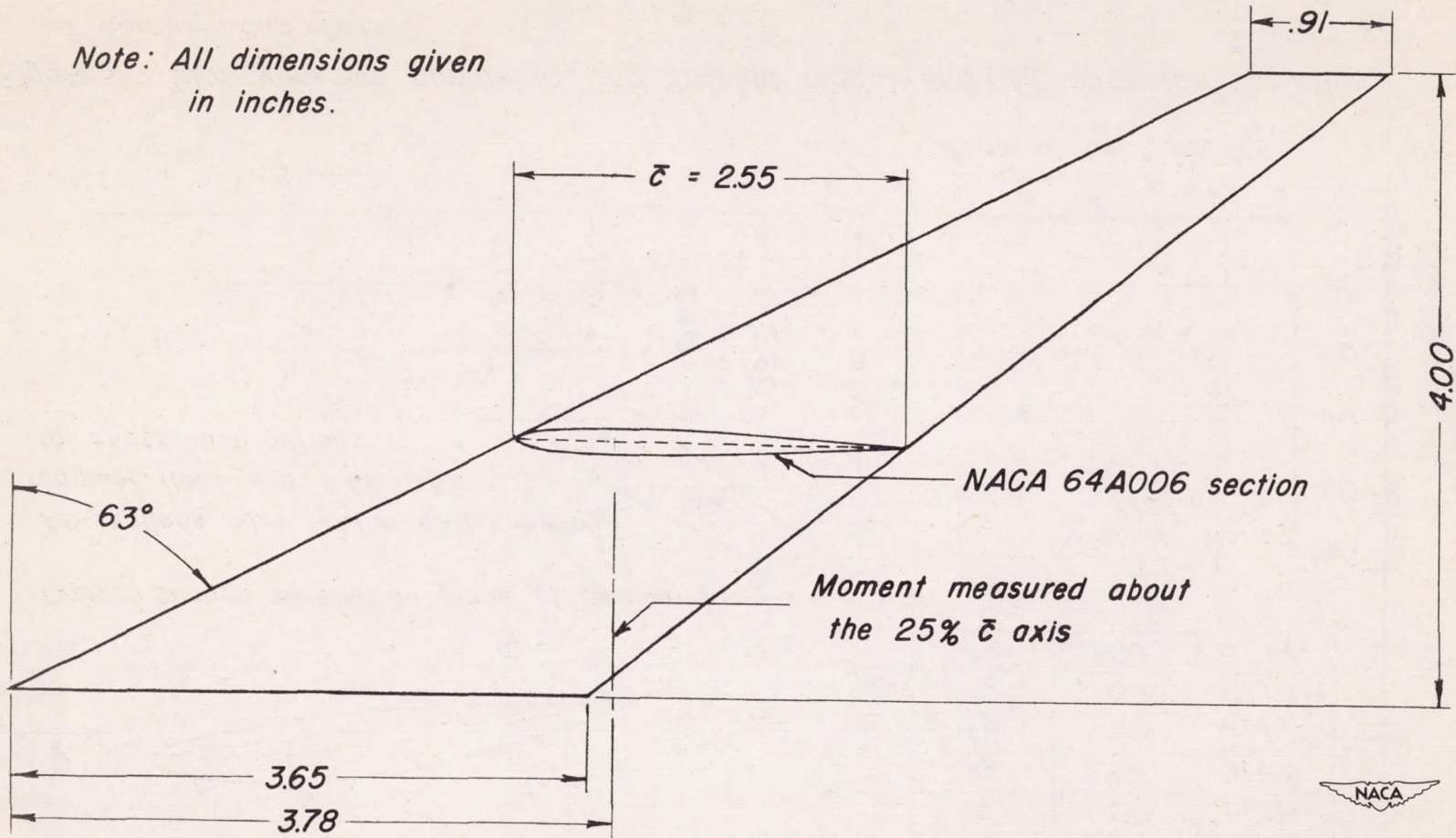
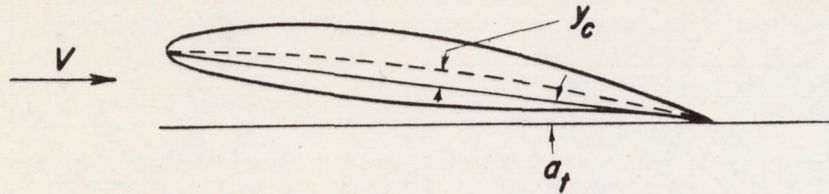

Figure 1.- Dimensional drawing of semispan of symmetrical untwisted wing showing basic plan form.

Spanwise camber distribution

Station	Percent semispan	Camber y_c/c
c_0	0	0
c_1	20	.0082
c_2	40	.0108
c_3	60	.0117
c_4	80	.0115
c_5	100	.0114

Note: All dimensions given in inches unless otherwise specified.



Typical section parallel to plane of symmetry

All sections have NACA $a=1.0$ mean-camber lines and 64A005 thickness distributions.

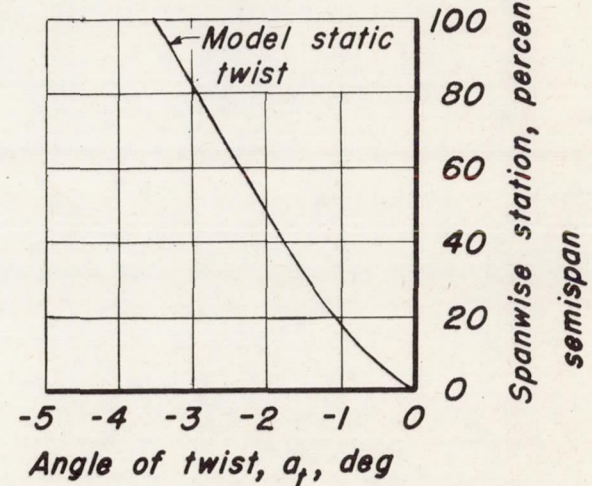
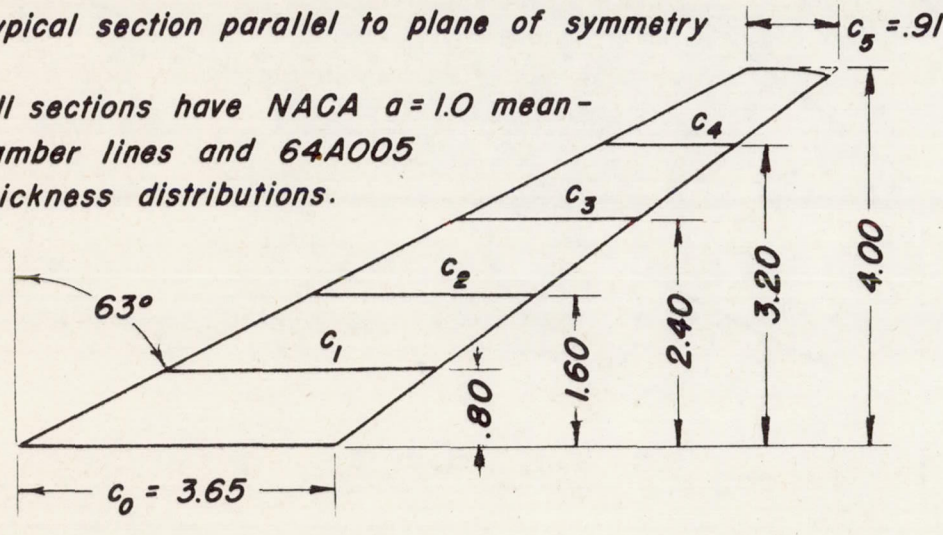
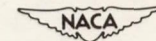
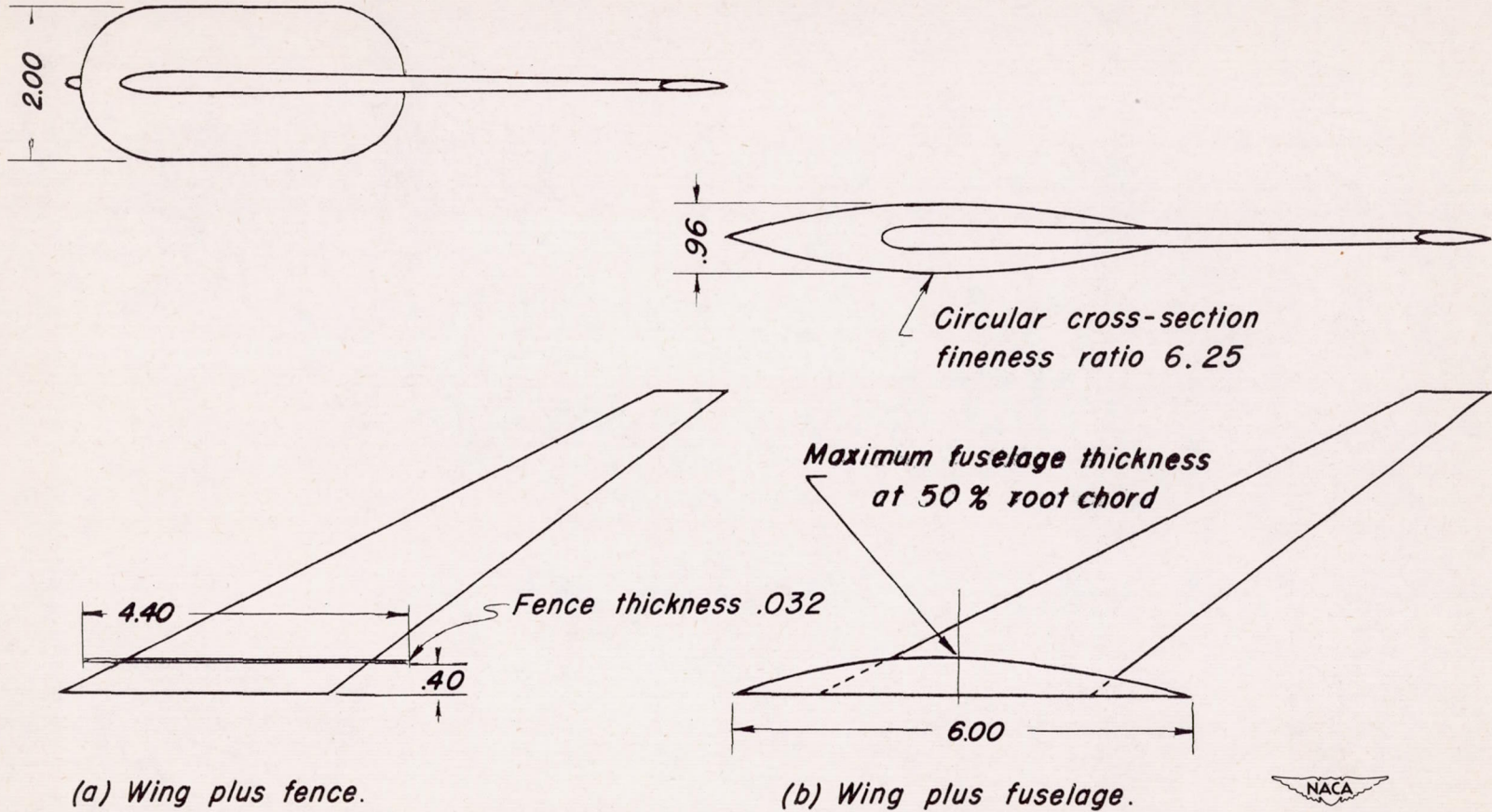

Figure 2.- Plan view of cambered and twisted model showing spanwise variation of camber and twist.



Note: All dimensions given in inches.



(a) Wing plus fence.

(b) Wing plus fuselage.



Figure 3.- Test-station boundary-layer-control fence and fuselage modification to original wing-alone symmetrical wing model.

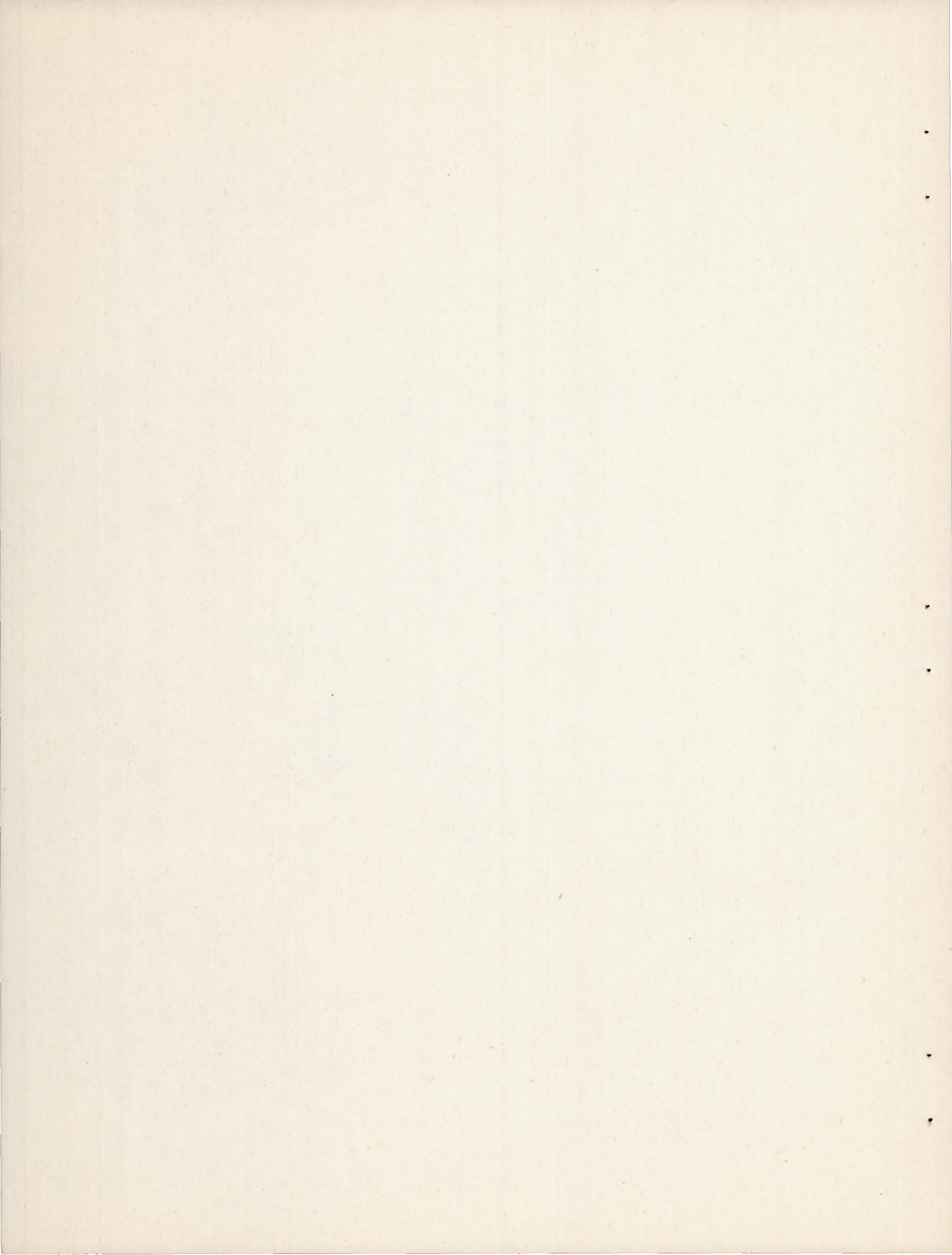

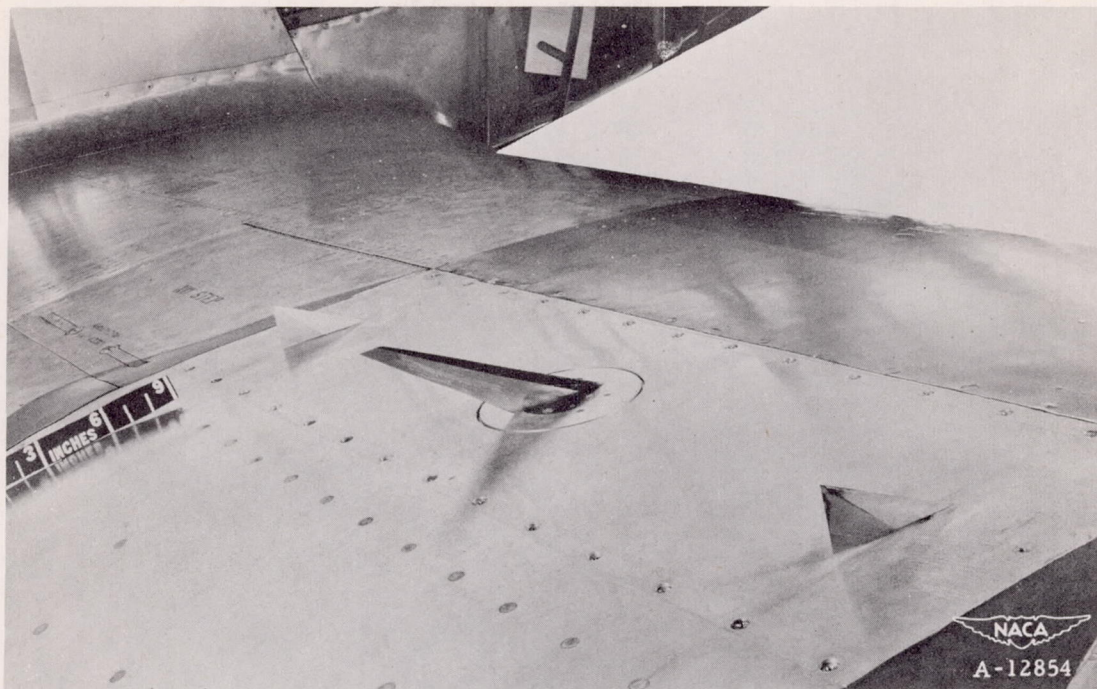

Figure 4.— General view of the wing-flow test station.

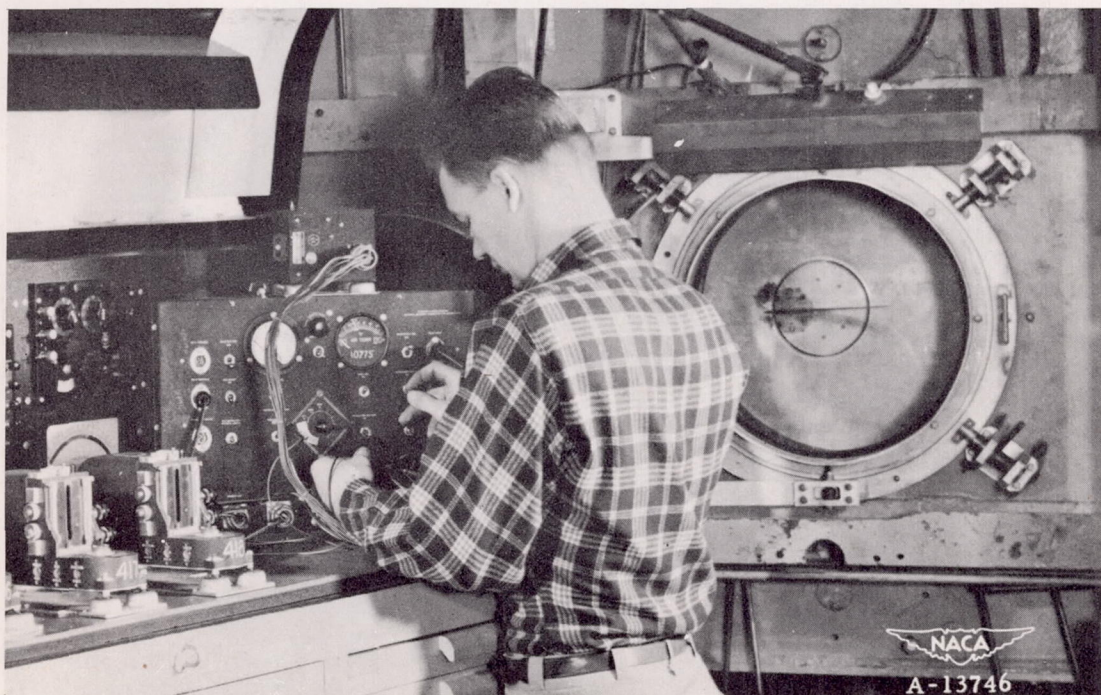
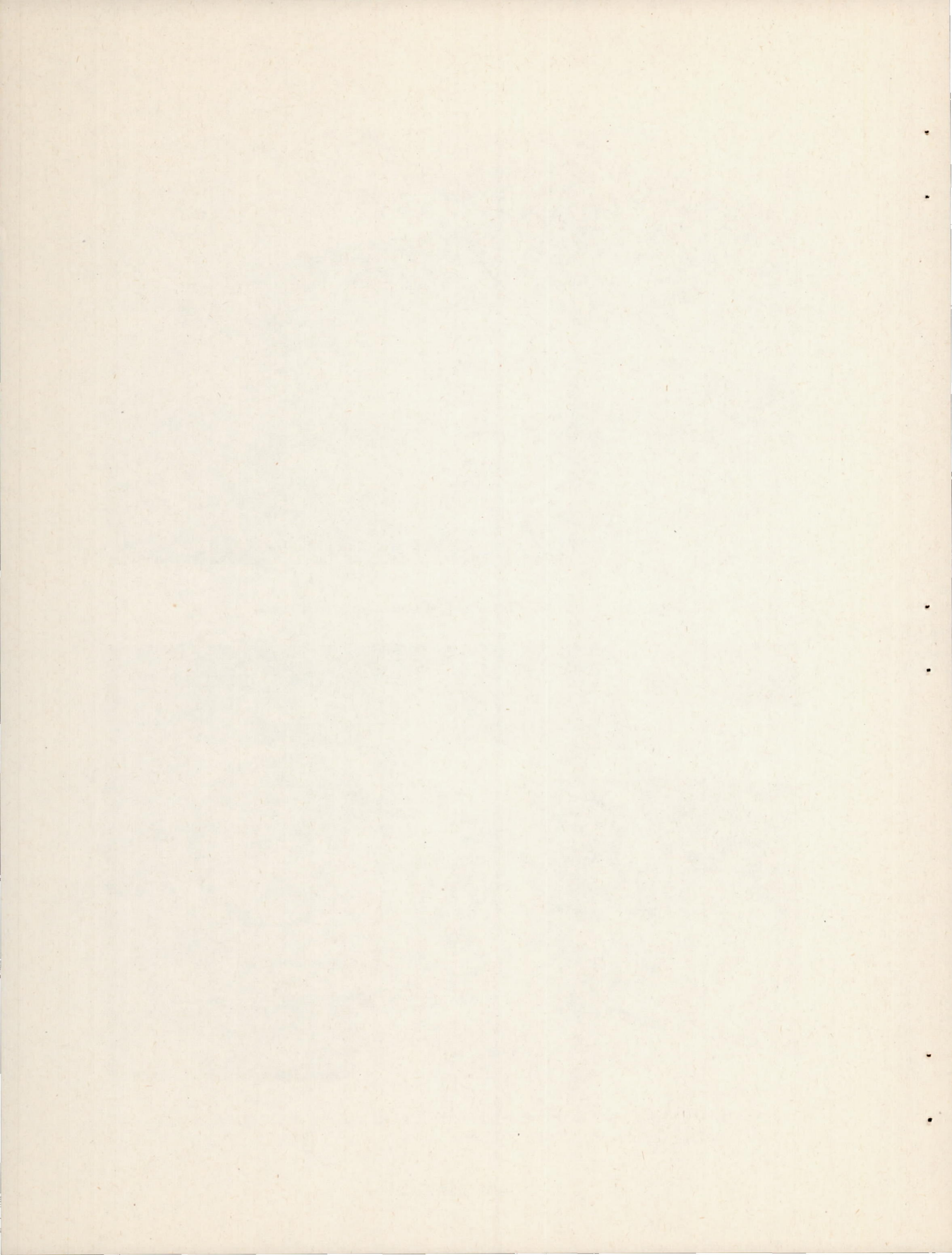
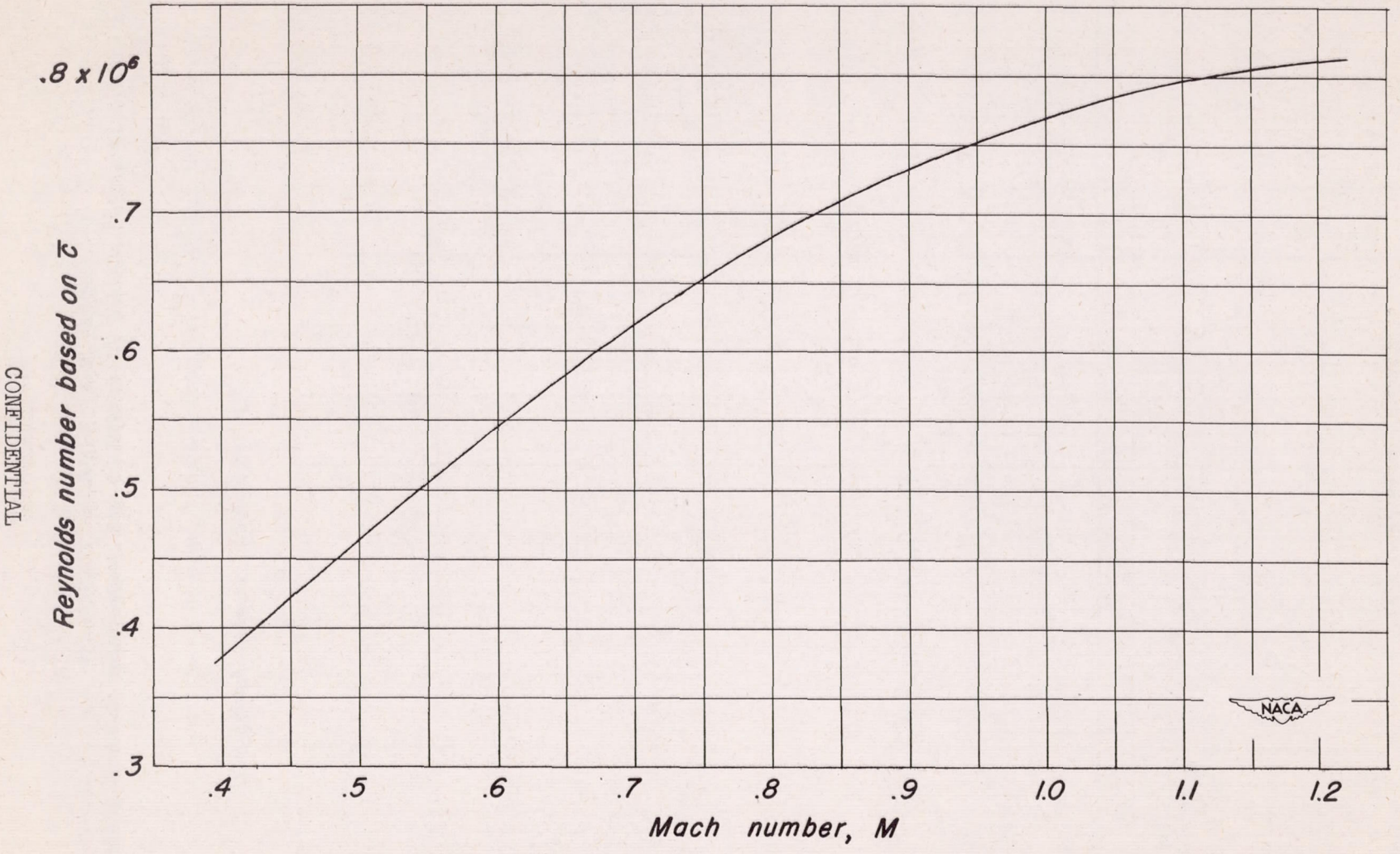

Figure 5.— Wing-flow balance and model mounted on wall of Ames 1- by 3-1/2-foot high-speed wind tunnel.





CONFIDENTIAL

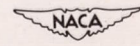
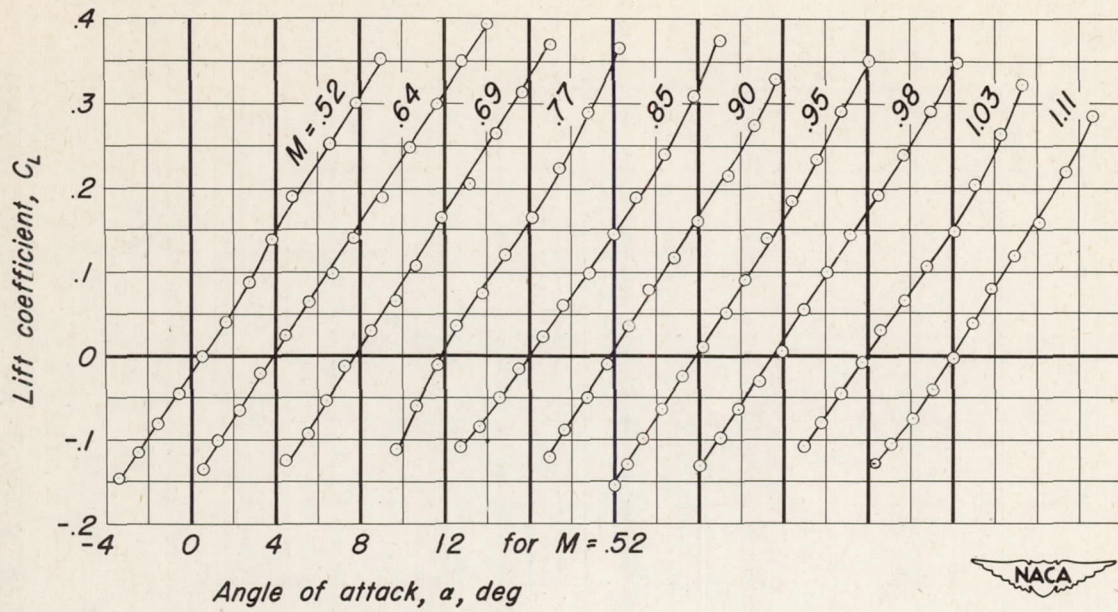
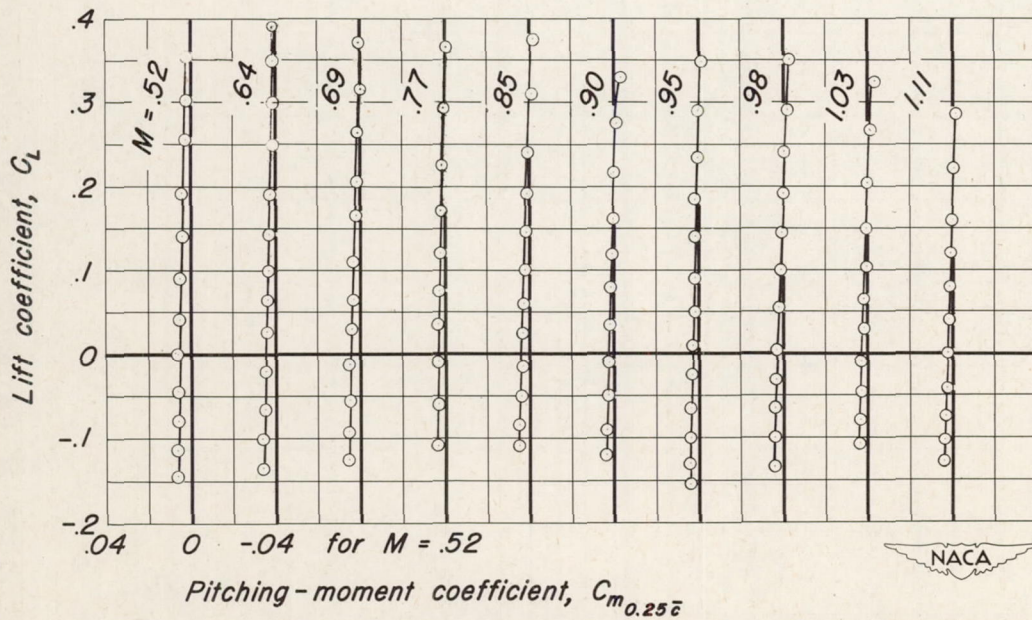

Figure 6.- Variation of Reynolds number with test-station Mach number for test configuration.



(a) Variation of lift coefficient with angle of attack.



(b) Variation of pitching-moment coefficient with lift coefficient.

Figure 7.-General aerodynamic characteristics at several values of Mach number for the symmetrical untwisted wing alone.

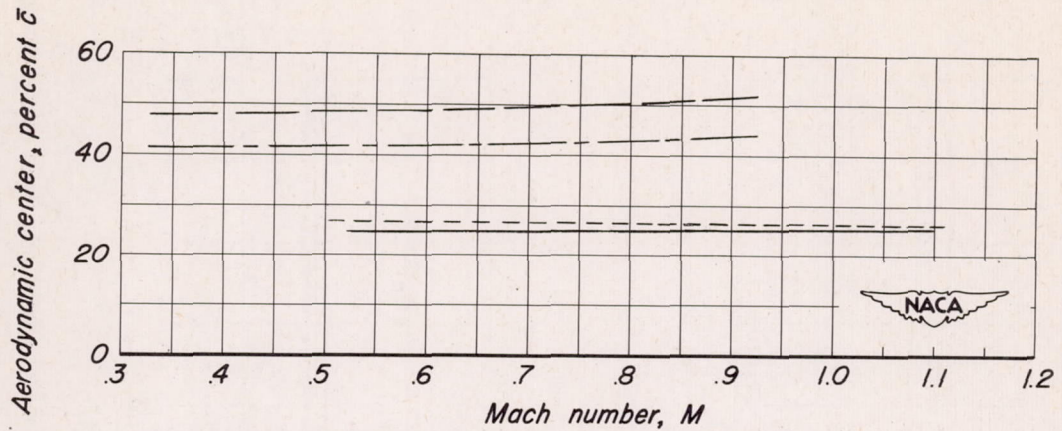

(a) Change in location of center of pressure with Mach number.

- Symmetrical wing, wing-flow method
- - - - Symmetrical wing, Ames 12-foot pressure wind tunnel, ref. 1
- - - - Cambered and twisted wing, wing-flow method
- Cambered and twisted wing, Ames 12-foot pressure wind tunnel, ref. 4

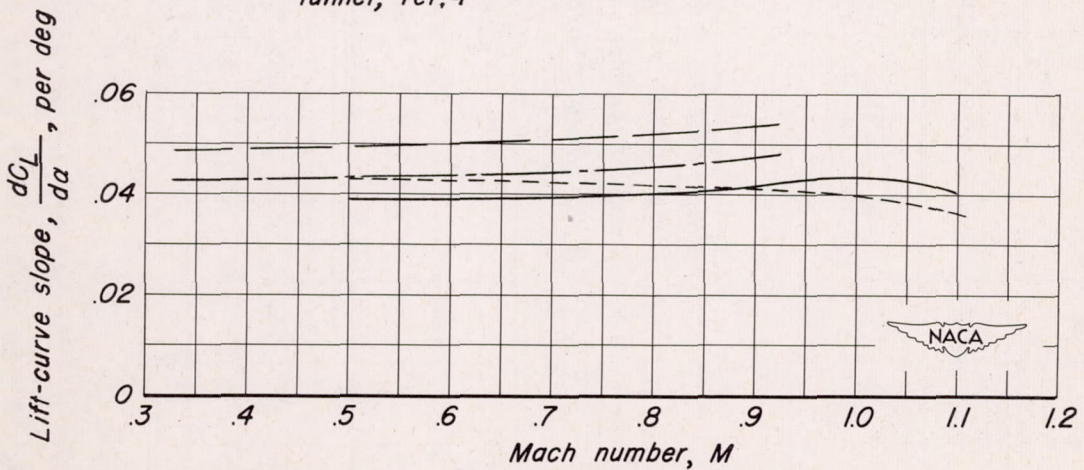

(b) Change in lift-curve slope with Mach number.

Figure 8.— Comparison between wing-flow data and data from the Ames 12-foot pressure wind tunnel for similar models.

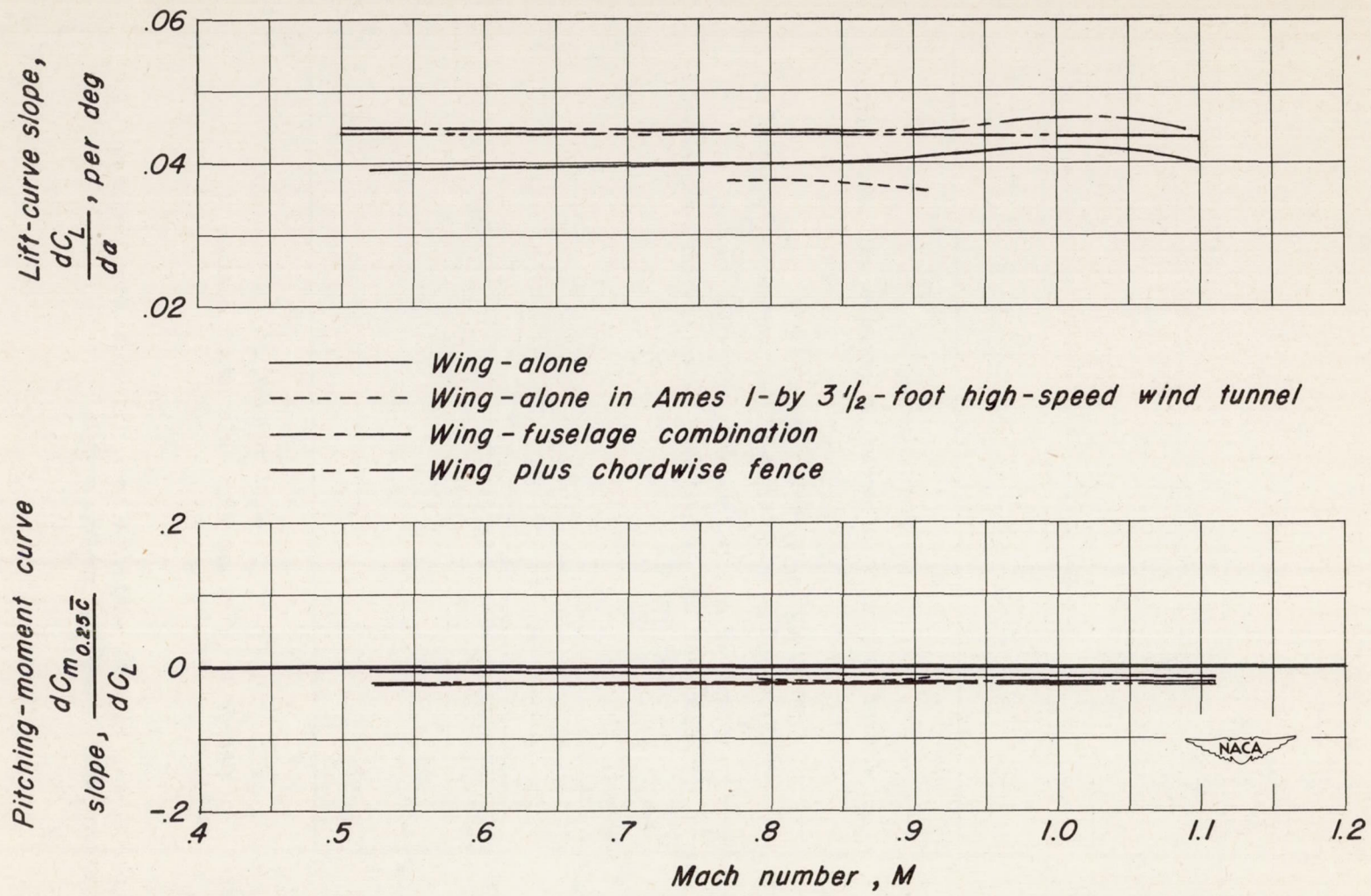

Figure 9.- Summary of the effect of various modifications to model configuration and test technique on the lift-curve slope and pitching-moment-curve slope. Symmetrical untwisted wing.