

RM E50H07

OCT 12 1950

C.2

NACA RM E50H07



RESEARCH MEMORANDUM

PERFORMANCE OF 4600-POUND-THRUST CENTRIFUGAL-FLOW-TYPE
TURBOJET ENGINE WITH WATER-ALCOHOL
INJECTION AT INLET

By Philip W. Glasser

Lewis Flight Propulsion Laboratory
Cleveland, Ohio

CLASSIFICATION CANCELLED

AL... Note R7 30274 Date 7/17/50

By MPH 7/31/50 Sec _____

CLASSIFIED DOCUMENT

This document contains classified information affecting the National Defense of the United States within the meaning of the Espionage Act, USC 50c31 and 52. Its transmission or the revelation of its contents in any manner to an unauthorized person is prohibited by law.

Information so classified may be imparted only to persons in the military and naval services of the United States, appropriate civilian officers and employees of the Federal Government who have a legitimate interest therein, and to United States citizens of known loyalty and discretion who of necessity must be informed thereof.

NATIONAL ADVISORY COMMITTEE FOR AERONAUTICS

WASHINGTON
October 9, 1950

~~CONFIDENTIAL~~



3 1176 01435 0095

1
NACA RM E50H07

NATIONAL ADVISORY COMMITTEE FOR AERONAUTICS

RESEARCH MEMORANDUM

PERFORMANCE OF 4600-POUND-THRUST CENTRIFUGAL-FLOW-TYPE

TURBOJET ENGINE WITH WATER-ALCOHOL

INJECTION AT INLET

By Philip W. Glasser

SUMMARY

1389

An experimental investigation of the effects of injecting a water-alcohol mixture of 2:1 at the compressor inlet of a centrifugal-flow-type turbojet engine was conducted in an altitude test chamber at static sea-level conditions and at an altitude of 20,000 feet with a flight Mach number of 0.78 with an engine operating at rated speed.

For a ratio of injected liquid to air flow of 0.05, an augmented thrust ratio of 1.16 was obtained at altitudes of both sea level and 20,000 feet. A further increase in the liquid-air ratio beyond 0.05 did not give a comparable increase in thrust. The augmentation was accompanied by an increase in the specific liquid consumption by a factor of 3.35 at sea level and 3.45 at an altitude of 20,000 feet.

INTRODUCTION

As part of a program undertaken to increase the thrust of turbojet engines by injecting a coolant at the compressor inlet (references 1 to 5), an investigation was conducted at the NACA Lewis laboratory to compare the effect of compressor-inlet water-alcohol injection on the performance of a centrifugal-flow-type turbojet engine at sea level and at a simulated-altitude flight condition.

The results presented herein indicate the effect of liquid injection on the over-all performance and on the pressures and the temperatures through the engine at static sea-level conditions and with a flight Mach number of 0.78 at an altitude of 20,000 feet.

CONFIDENTIAL

APPARATUS AND INSTRUMENTATION

Engine

The J33-A-23 turbojet engine used in this investigation had a static sea-level thrust rating of 4600 pounds at maximum engine speed (11,750 rpm) and limiting turbine-outlet temperature of 1700° R. When operating under these conditions with compressor-inlet liquid injection, the engine had a rated static sea-level thrust of 5400 pounds. The engine includes a double-entry centrifugal-flow compressor, 14 through-flow can-type combustors, a single-stage turbine, and a fixed-area exhaust nozzle. Over-all length of the engine is 107 inches; over-all diameter is $50\frac{1}{2}$ inches; and the weight is 1795 pounds.

The water-alcohol manifold and the nozzle assembly, which was standard equipment on this model engine, consisted of 14 nozzles equally spaced around both the front and rear compressor-inlet screens. A simple orifice-plate-type nozzle was used that had a capacity of 93.5 gallons per hour and a spray angle of $65^\circ \pm 10^\circ$ at 35 pounds per square inch with an oil having a Saybolt viscosity of 34 seconds at 100° F.

Altitude Chamber

The engine was installed in an altitude chamber 10 feet in diameter and 60 feet long (fig. 1). The engine was mounted on a thrust frame, which was connected through a linkage to a balance-pressure diaphragm-type thrust indicator. A cowl was mounted around the engine to prevent heated air, which circulated in the region of the tail pipe upstream of the bulkhead, from entering the engine inlet without first mixing with the incoming air. The tail pipe extended through the bulkhead, which separated the test section from the exhaust section. A flexible seal prevented recirculation of exhaust gases between the tail pipe and the bulkhead and permitted freedom of movement of the engine so as not to interfere with thrust readings obtained on the balance system.

Inlet- and exhaust pressures were controlled by means of butterfly valves located upstream and downstream of the chamber, as noted in figure 1. Temperature adjustments were made either by mixing refrigerated air at approximately 420° R with combustion air at approximately 540° R, or by heating a portion of the combustion air in a bank of electric heaters located in a bypass of the air supply line.

Instrumentation

Pressures and temperatures were recorded for several stations throughout the engine from the cowl inlet to the exhaust-nozzle outlet (fig. 2). Details of the pertinent instrumentation at each station are presented in figure 3. The cowl-inlet thermocouples (fig. 3(a)) were used in setting the inlet temperature. Temperatures measured at station 2 (fig. 3(b)) were used as a check on the cowl-inlet measurements and indicated the temperature distribution at the compressor inlet. Total-pressure probes installed on the inlet screens at station 2 (fig. 3(b)) were used in setting the engine-inlet pressure. Two static-pressure tubes located in the exhaust section of the test chamber (fig. 2) were used to set altitude pressure.

The fuel used, specification AN-F-32, was measured by a calibrated variable-area-orifice flowmeter. Calibrated rotameters were used to measure the individual rates of alcohol, specification AN-A-24, and water.

PROCEDURE

The investigation was conducted at both sea-level static pressure and a pressure altitude of 20,000 feet with a flight Mach number of 0.78. The engine was operated at rated speed, 11,750 rpm, and inlet total temperatures were maintained at 550° and 503° R at sea level and 20,000 feet, respectively. Data were obtained over a range of injected flow rates corresponding to liquid-air ratios up to 0.053 at sea level and 0.070 at an altitude of 20,000 feet.

At both altitudes, a water-alcohol ratio of 2:1 by volume was injected through the nozzles at the compressor inlet. This particular ratio had been selected so that constant engine speed could be maintained over a range of injection rates with a nearly constant throttle setting. The water used was de-ionized to retard deterioration of the engine components. The water and the alcohol were supplied separately from storage tanks through the rotameters to a mixing chamber. The mixture then entered the injection manifolds at the compressor inlet. The water and the alcohol systems were individually operated and the flow through each could be separately controlled.

The data obtained in this investigation were corrected for small deviations in the inlet temperature and pressure from the standard altitude values. The symbols and the method of calculating the performance parameters used in figures 4 to 9 are presented in appendixes A and B, respectively.

RESULTS AND DISCUSSION

The effect of injecting liquid at the compressor inlet on the engine performance is shown in figures 4 to 6, wherein compressor-outlet and turbine-outlet temperatures and pressures and engine air flow are shown as functions of the liquid-air ratio for flight conditions corresponding to static sea level and an altitude of 20,000 feet at a flight Mach number of 0.78. Increasing the liquid-air ratio resulted in a reduction in compressor-outlet and turbine-outlet temperatures and a rise in compressor pressure ratio, turbine-outlet total pressure, and air flow. An increase in liquid-air ratio above a value of about 0.05 had only a slight effect on each variable.

Evaporation of liquid during the compression process resulted in the reduction in compressor-outlet temperature and attendant rise in compressor pressure ratio. The reduction in compressor-outlet temperature accompanying an increase in liquid-air ratio to 0.05 amounted to 207° R at sea level as compared to 217° R at an altitude of 20,000 feet. The attendant increases in compressor pressure ratio were 9 and 7 percent, respectively. (See fig. 4.) Similarly, with the increase in liquid-air ratio to 0.05, the air flow (fig. 5) was raised 7 percent at sea level and 5 percent at an altitude of 20,000 feet. The smaller performance variation at an altitude of 20,000 feet than at sea level is attributed to a decrease in evaporative effectiveness as a result of the reduction in inlet temperature.

With an increase in liquid-air ratio to 0.05, the turbine-outlet temperature was reduced 90° R at sea level and 50° R at an altitude of 20,000 feet, reaching a minimum of 1700° R at both altitudes (fig. 6). The accompanying increase in turbine-outlet pressure at these conditions was 7 and 10 percent, respectively.

The increase in augmented net thrust and augmented net-thrust ratio (ratio of augmented thrust to unaugmented thrust) with liquid-air ratio is shown in figure 7. An increase in liquid-air ratio from 0 to 0.05 increased the sea-level thrust 690 pounds above its unaugmented value of 4320 pounds. Approximately half the difference between the unaugmented thrust and rated thrust is attributable to the high engine-inlet temperature. The augmented thrust ratio amounted to 1.16 at a liquid-air ratio of 0.05 for both sea-level and altitude flight conditions. Use of a variable-area exhaust nozzle, which would enable operation at limiting turbine-outlet temperature, would afford a slight additional thrust gain. The rate of increase in augmented thrust with liquid-air ratio diminished above a liquid-air ratio of 0.05.

1389

Similar increases in the augmented thrust ratio at the two flight conditions is the coincidental result of two different effects. The air-flow increase at sea level exceeded that at 20,000 feet (7 percent as compared with 5 percent); whereas the turbine-outlet pressure, of which the jet velocity is a function, increased more at altitude than at sea level in the ratio of 10 to 7 percent. The combination of these two increases resulted in the same increase in augmented thrust ratio in both cases.

The major portion of the thrust gain was contributed by the increase in mass flow through the engine, which was approximately equally divided between increased liquid consumption and increased air flow. Only about one-third of the net thrust increase was attributable to the increased jet velocity arising from the increased turbine-outlet pressure. The increase in jet velocity was computed from the turbine-outlet conditions shown in figure 6, with the assumption of expansion to ambient pressure. Thrust-augmentation results on a 4000-pound-thrust centrifugal-flow-type turbojet engine (reference 1) at sea level showed an augmented thrust ratio of 1.24 for a liquid-air ratio of 0.053 with a water-alcohol mixture of 2:1. On this engine, the increase in mass flow and jet velocity contributed equally to the increase in thrust.

The fuel flow remained constant as liquid was injected at the compressor inlet, as shown in figure 8, indicating that a mixture of water and alcohol of 2:1 was correct for constant-throttle engine operation with liquid injection. Because the fuel flow did remain constant, the total liquid consumption increased approximately linearly with the liquid-air ratio.

The specific liquid consumption, which is the total liquid consumption per pound of thrust, is presented in figure 9 as a function of liquid-air ratio. The specific liquid consumption increased approximately linearly with liquid-air ratio for both altitudes and reached a value of 4.0 at sea level and 4.7 at 20,000 feet for a liquid-air ratio of 0.05. The specific liquid consumption of the augmented engine at this liquid-air ratio is thus 3.35 and 3.45 times that of the unaugmented engine for altitudes of sea level and 20,000 feet, respectively.

SUMMARY OF RESULTS

The following results were obtained from the investigation conducted in an altitude test chamber of water-alcohol injection at the inlet of a centrifugal-flow turbojet engine.

~~CONFIDENTIAL~~

1. An augmented net thrust ratio of 1.16 was obtained at a liquid-air ratio of 0.05 at both sea-level static conditions with a compressor-inlet temperature of 550° R and for an altitude of 20,000 feet, with a compressor-inlet temperature of 503° R and a flight Mach number of 0.78. Increasing the liquid-air ratio beyond 0.05 did not result in a significant gain in thrust.

2. Increasing the liquid-air ratio to 0.05 increased the net-thrust specific liquid consumption by a factor of 3.35 at sea level and 3.45 at an altitude of 20,000 feet.

Lewis Flight Propulsion Laboratory,
National Advisory Committee for Aeronautics,
Cleveland, Ohio.

APPENDIX A

SYMBOLS

The following symbols were used in this report:

A	area, sq ft
F_j	jet thrust, lb
F_n	net thrust, lb
$F_{n,a}$	augmented net thrust, lb
g	acceleration due to gravity, 32.2 ft/sec ²
ΔH	total enthalpy minus static enthalpy, Btu/lb
J	mechanical equivalent of heat, 778 ft-lb/Btu
P	total pressure, lb/sq ft
p	static pressure, lb/sq ft
R	gas constant, 53.3 ft-lb/(lb)(°R)
T	total temperature, °R
t	static temperature, °R
V	velocity, ft/sec
W_a	air flow, lb/sec
W_f	fuel flow, lb/sec
W_g	gas flow, lb/sec
W_i	injected-liquid flow, lb/sec
γ	ratio of specific heats

Subscripts:

ind indicated

s seal

0 free-stream conditions

1-7 stations shown in figure 2

Prime denotes a quantity introduced by use of reference 6.

~~CONFIDENTIAL~~

APPENDIX B

METHOD OF CALCULATION

Air flow. - Temperatures recorded by a thermocouple ring at station 5 (fig. 3(e)) and pressures recorded by a rake about 1 diameter farther downstream at station 6 (fig. 3(f)) were used in the calculation of air flow. The temperatures and the pressures were arithmetically averaged to give total and static tail-pipe pressures (P_6, p_6) and an indicated tail-pipe total temperature $T_{5,ind}$. An average recovery factor of 0.8 was determined from thermocouple calibrations and therefore

$$(T_{5,ind} - t_5) = 0.8 (T_5 - t_5) \quad (B1)$$

The use of the air charts (reference 6) introduced a fictitious quantity t_5' , and required the assumption that

$$\frac{T_{5,ind}}{t_5'} = \frac{T_5}{t_5} = \left(\frac{P_6}{p_6}\right)^{\frac{\gamma-1}{\gamma}} \quad (B2)$$

and that

$$T_{5,ind} - t_5' \approx T_5 - t_5 \quad (B3)$$

The static temperature was then determined by combining equations (B1) and (B3) as follows:

$$t_5 = 0.2 T_{5,ind} + 0.8 t_5' \quad (B4)$$

When the tail-pipe static temperature had been calculated, the gas flow was determined from the equation

$$W_g = \frac{A_6 P_6}{R t_5} \sqrt{2gJ \Delta H_5} \quad (B5)$$

The enthalpy was obtained from reference 6. After the fuel and injected liquid flow were measured, the air flow was computed by,

$$W_a = W_g - W_f - W_l \quad (B6)$$

~~CONFIDENTIAL~~

The air flow as calculated herein employed values of γ and R for NACA standard air. The air flow was calculated for the highest injection rate investigated using values of γ and R , which considered the injected liquid. The air flow thus calculated was less than 2 percent lower than that calculated for standard air and the effect of change in R and γ was considered negligible.

Thrust. - The jet thrust F_j was the balance-frame indicated value plus a correction factor for the pressure differential across the seal at the rear bulkhead.

$$F_j = F_{j,ind} + A_s (P_1 - P_0) \quad (B7)$$

The inlet momentum of the air was subtracted from jet thrust to give net thrust:

$$F_n = F_j - \frac{W_a V_0}{g} \quad (B8)$$

where

$$V_0 = \sqrt{2gJ \Delta H_0} \quad (B9)$$

REFERENCES

1. Jones William L., and Engleman, Helmuth W.: Experimental Investigation of Thrust Augmentation of 4000-Pound-Thrust Centrifugal-Flow-Type Turbojet Engine by Injection of Water and Alcohol at Compressor Inlets. NACA RM E7J19, 1948.
2. Dietz, Robert O., and Fleming, William A.: Altitude-Wind-Tunnel Investigation of Thrust Augmentation of a Turbojet Engine. II - Performance with Water Injection at Compressor Inlet. NACA RM E7C12, 1947.
3. Hall, Eldon W., and Wilcox, E. Clinton: Theoretical Comparison of Several Methods of Thrust Augmentation for Turbojet Engines. NACA Rep. 992, 1950.
4. Shillito, Thomas B., and Harp, James L., Jr.: Effect of Inlet Temperature and Humidity on Thrust Augmentation of Turbojet Engine by Compressor-Inlet Injection. NACA RM E50D19, 1950.

5. Jones, William L., and Downman, Harry W.: Experimental Investigation of Thrust Augmentation of a 1600-Pound-Thrust Centrifugal-Flow-Type Turbojet Engine by Injection of Refrigerants at Compressor Inlets. NACA RM E7G23, 1947.
6. Amorosi, A.: Gas Turbine Gas Charts. Res. Memo. No. 6-44 (Navships 250-330-6), Bur. Ships, Navy Dept., 1944.

1389

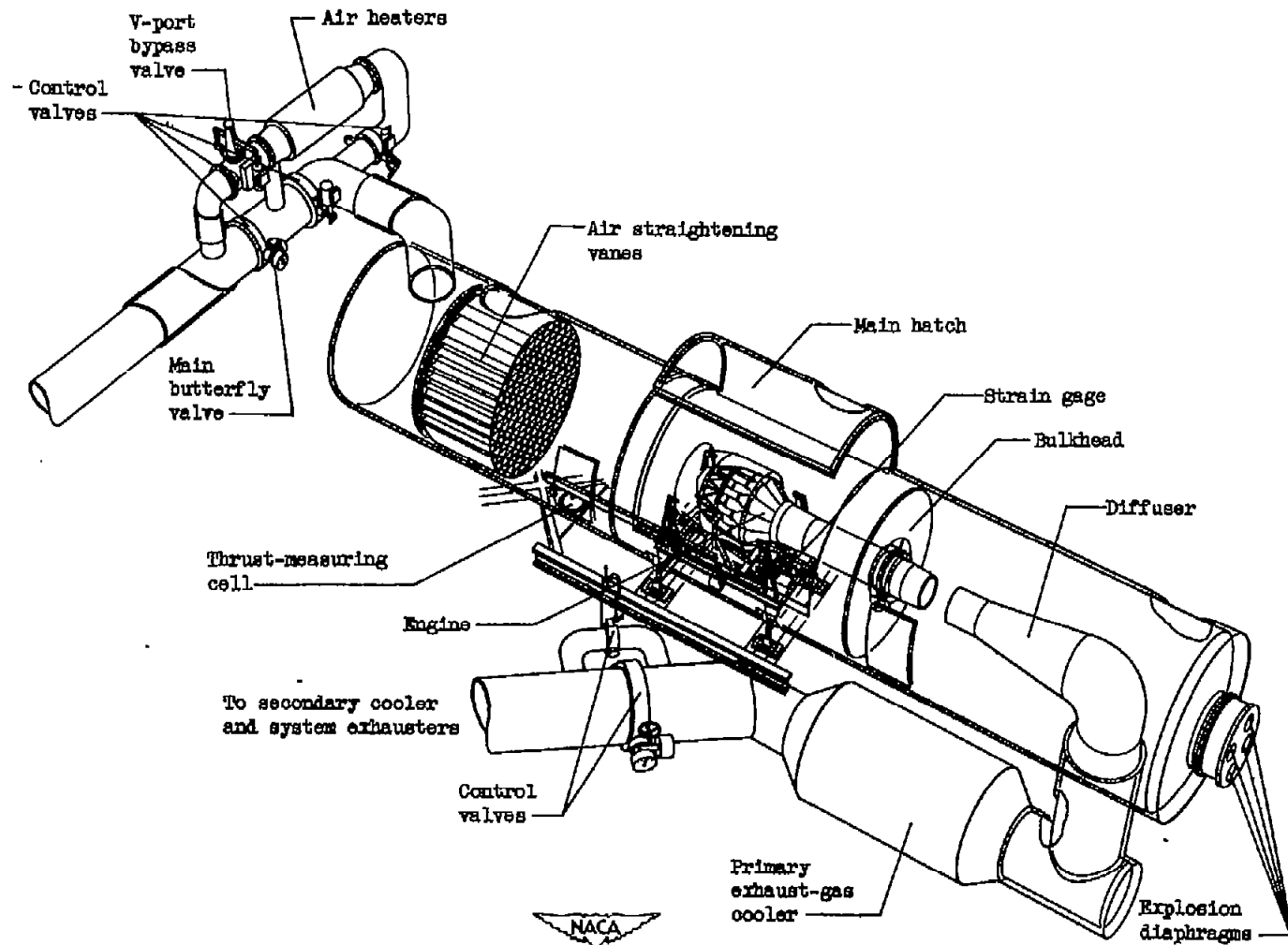

415-1844

Figure 1. - Altitude chamber with engine installed in test section.

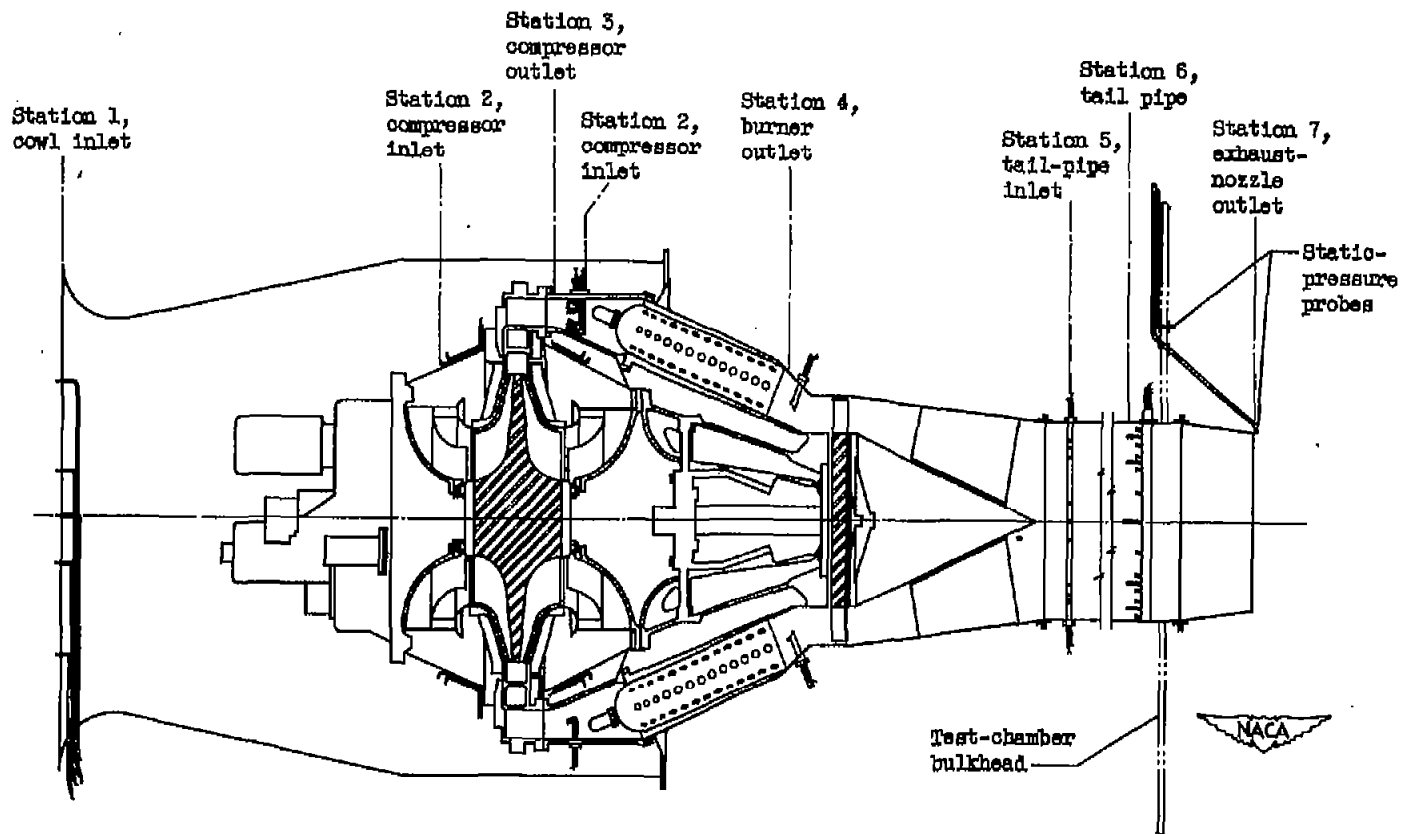
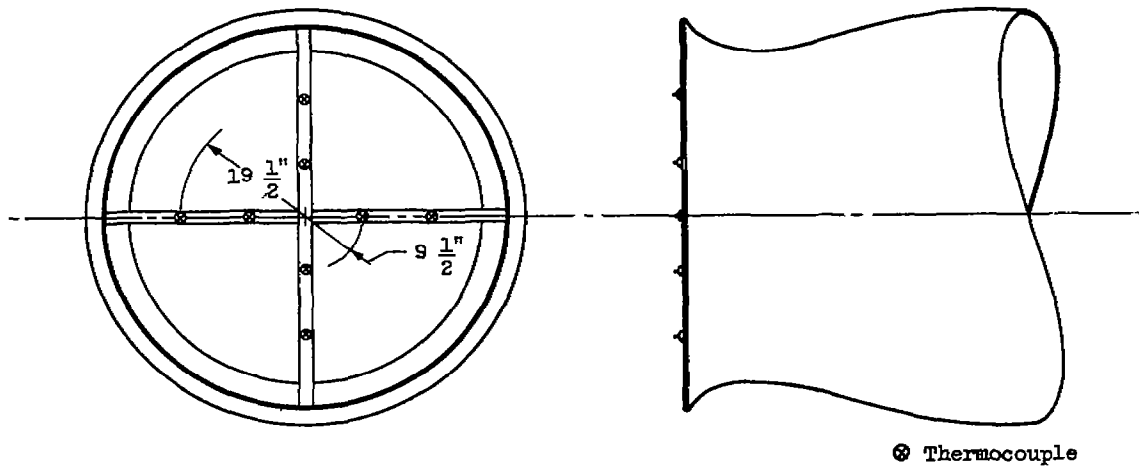
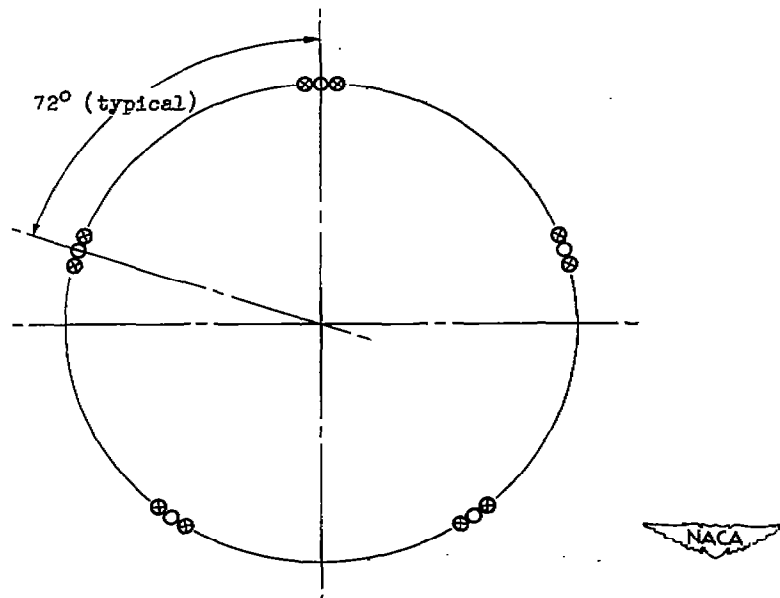

Figure 2. - Sectioned elevation view of turbojet engine showing stations at which instrumentation was installed.



(a) Station 1, cowl inlet.



○ Total-pressure probe

⊗ Thermocouple

(b) Station 2, compressor inlet; front and rear screens.

Figure 3. - Continued. Instrumentation at stations throughout engine.

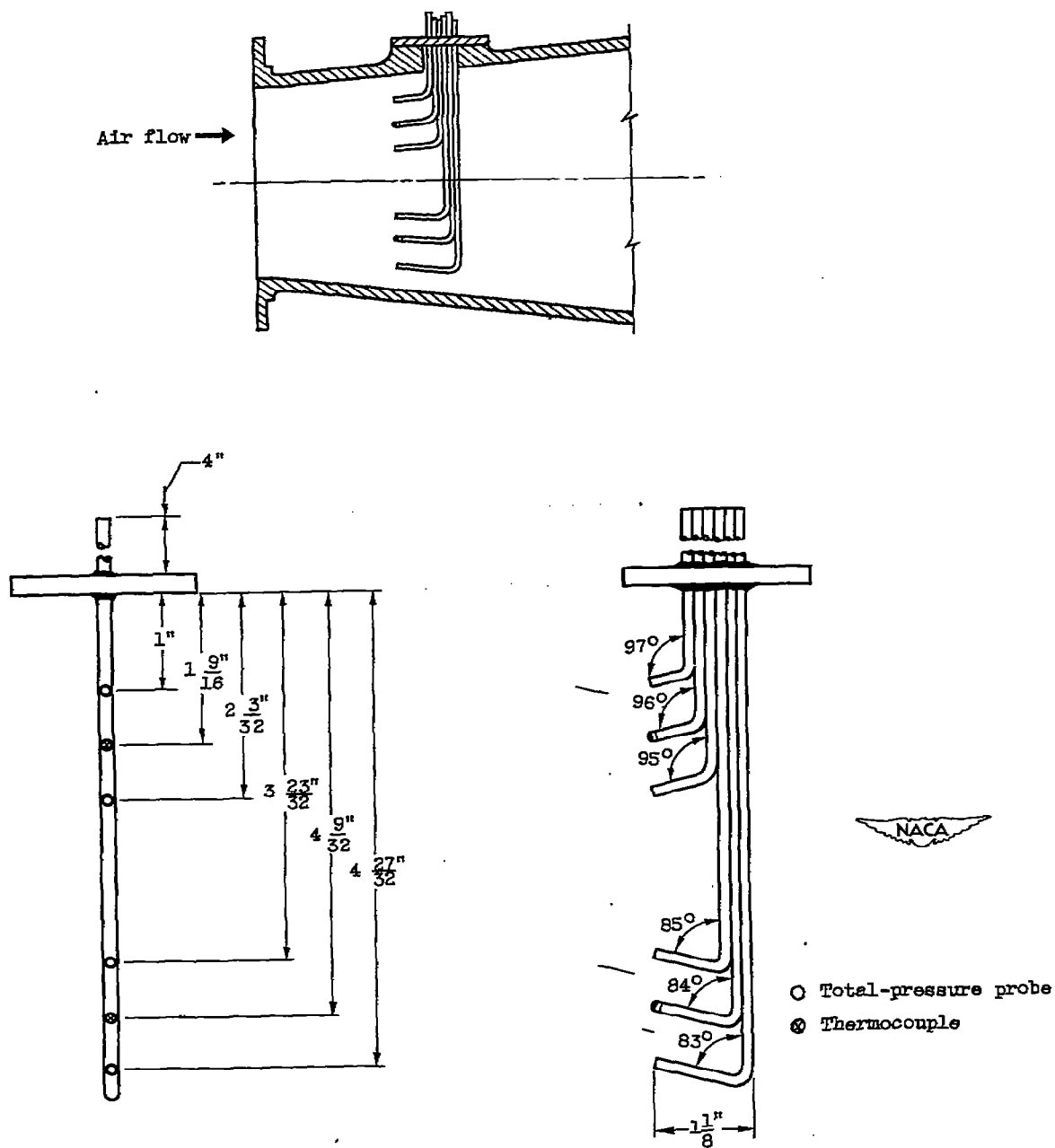

(c) Station 3, compressor outlet. Three rakes.

Figure 3. - Continued. Instrumentation at stations throughout engine.

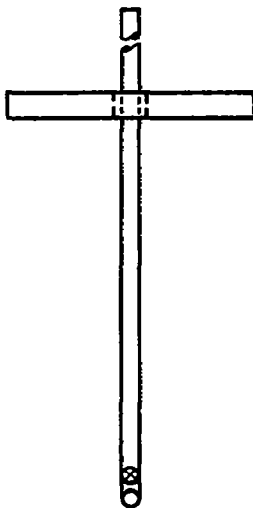
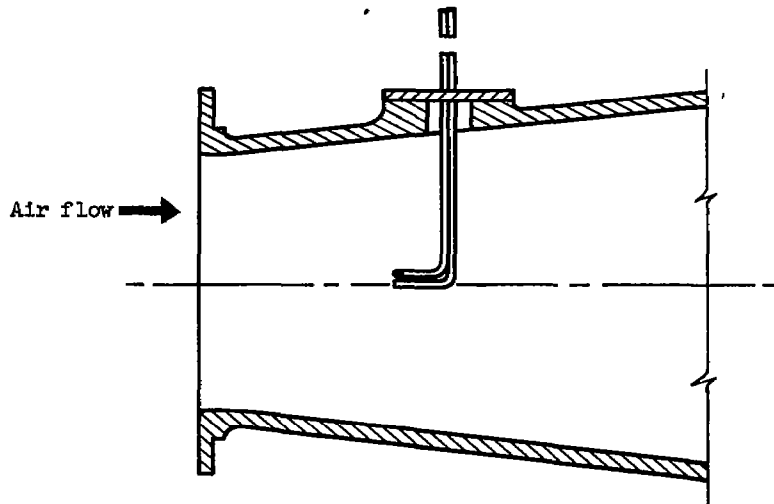

○ Total-pressure probe
 ⊗ Thermocouple

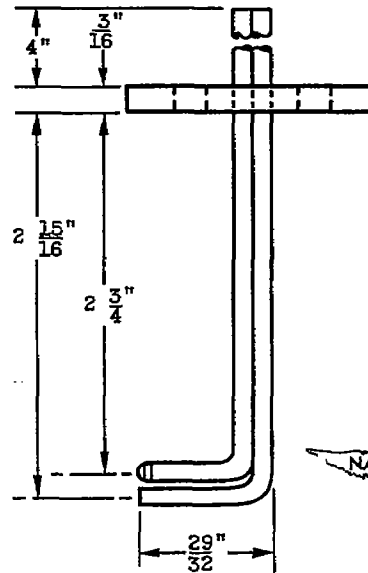

(d) Station 3, compressor outlet. Four rakes.

Figure 3. - Continued. Instrumentation at stations throughout engine.

3

1389

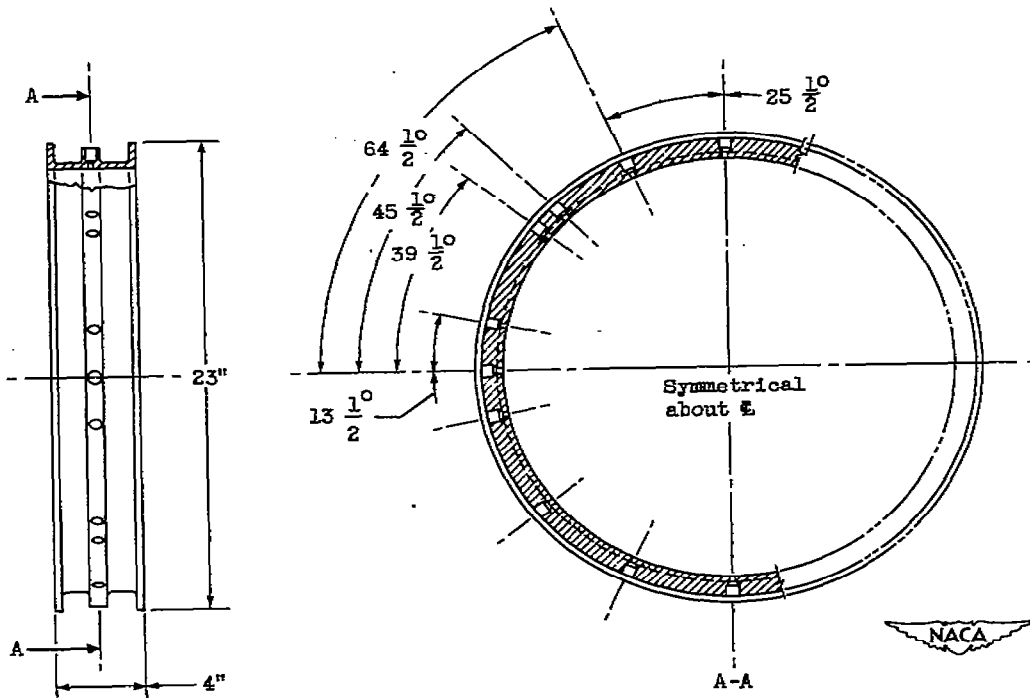
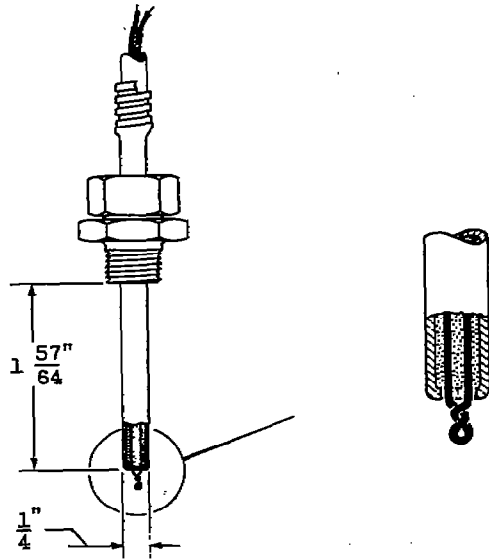

422-1559

(e) Station 5, tail-pipe inlet; thermocouple ring.

Figure 3. - Continued. Instrumentation at stations throughout engine.

~~CONFIDENTIAL~~

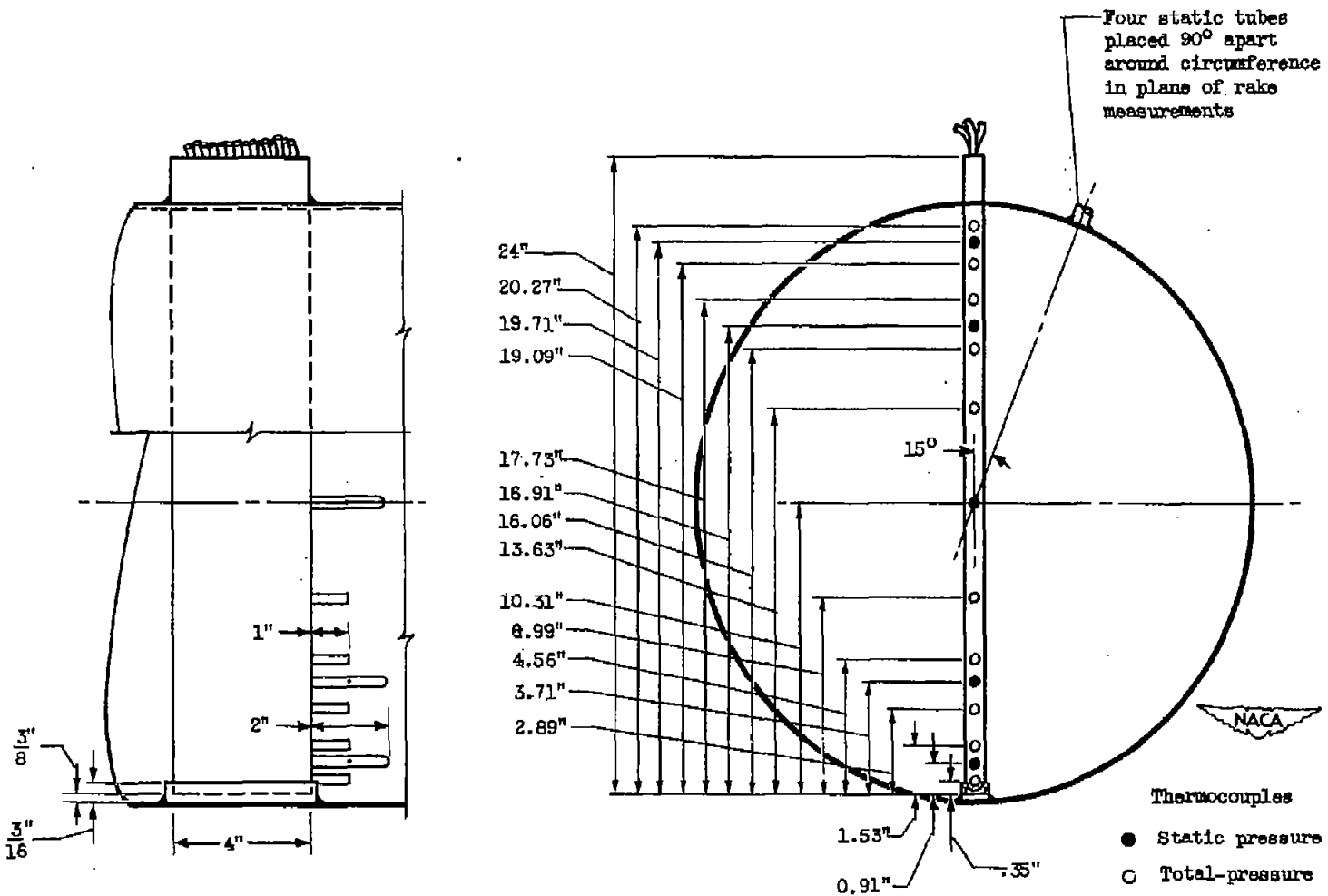

(f) Station 6, tail pipe; pressure rake.

Figure 3. - Concluded. Instrumentation at stations throughout engine.

1389

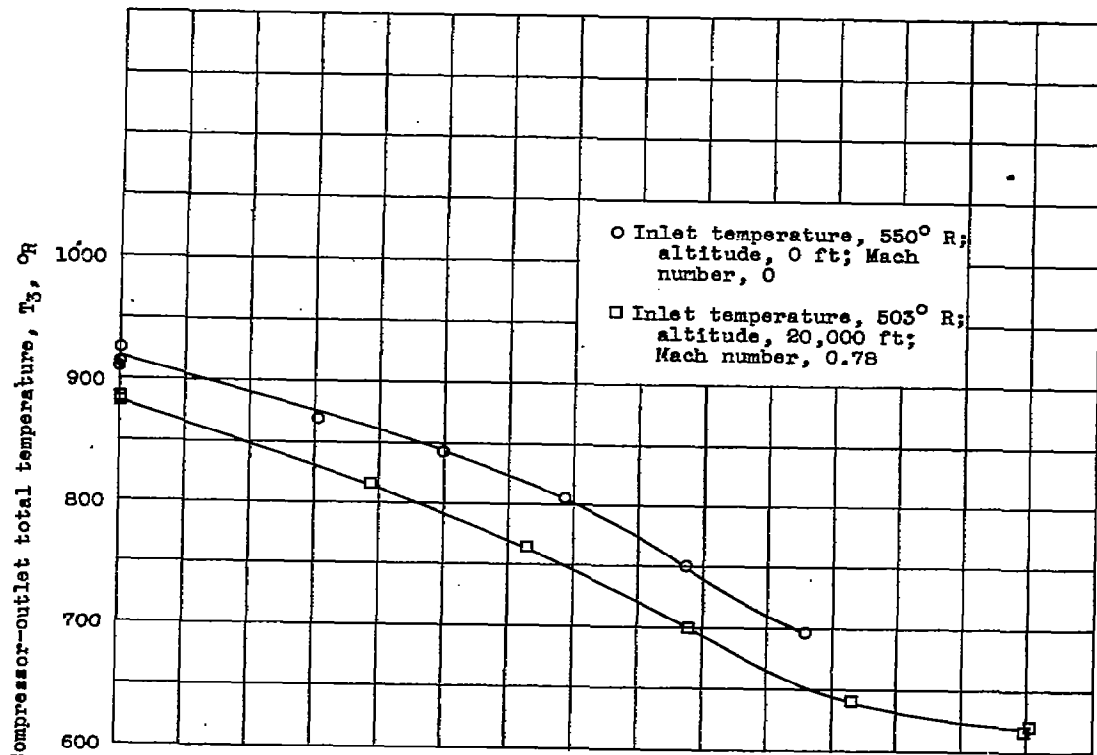

(a) Compressor-outlet total temperature.

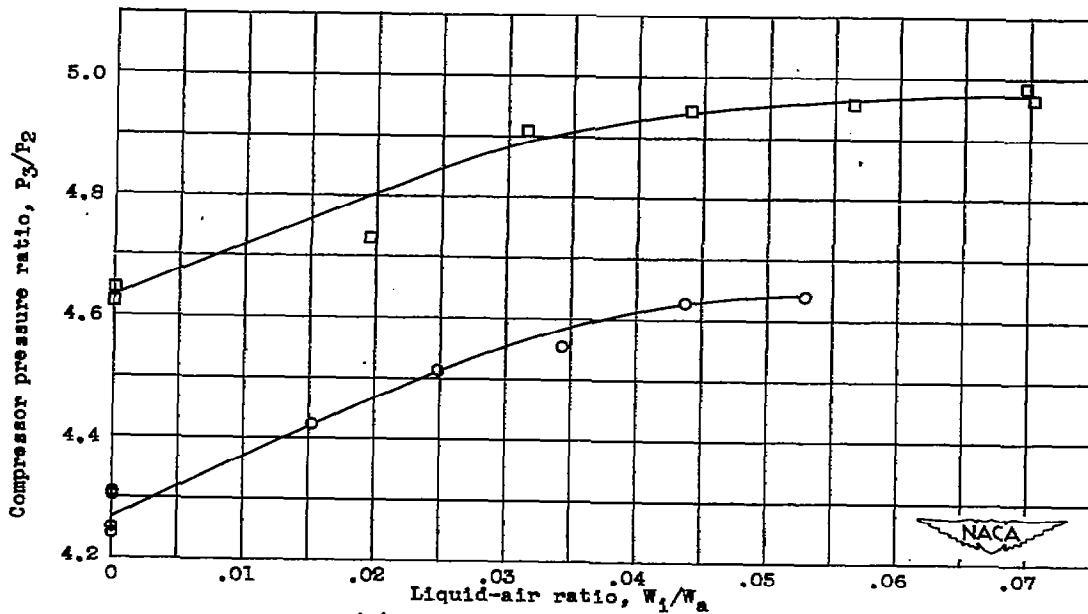

(b) Compressor pressure ratio.

Figure 4. - Compressor performance as function of liquid-air flow ratio. Rated engine speed, 11,750 rpm; water-alcohol ratio, 2:1.

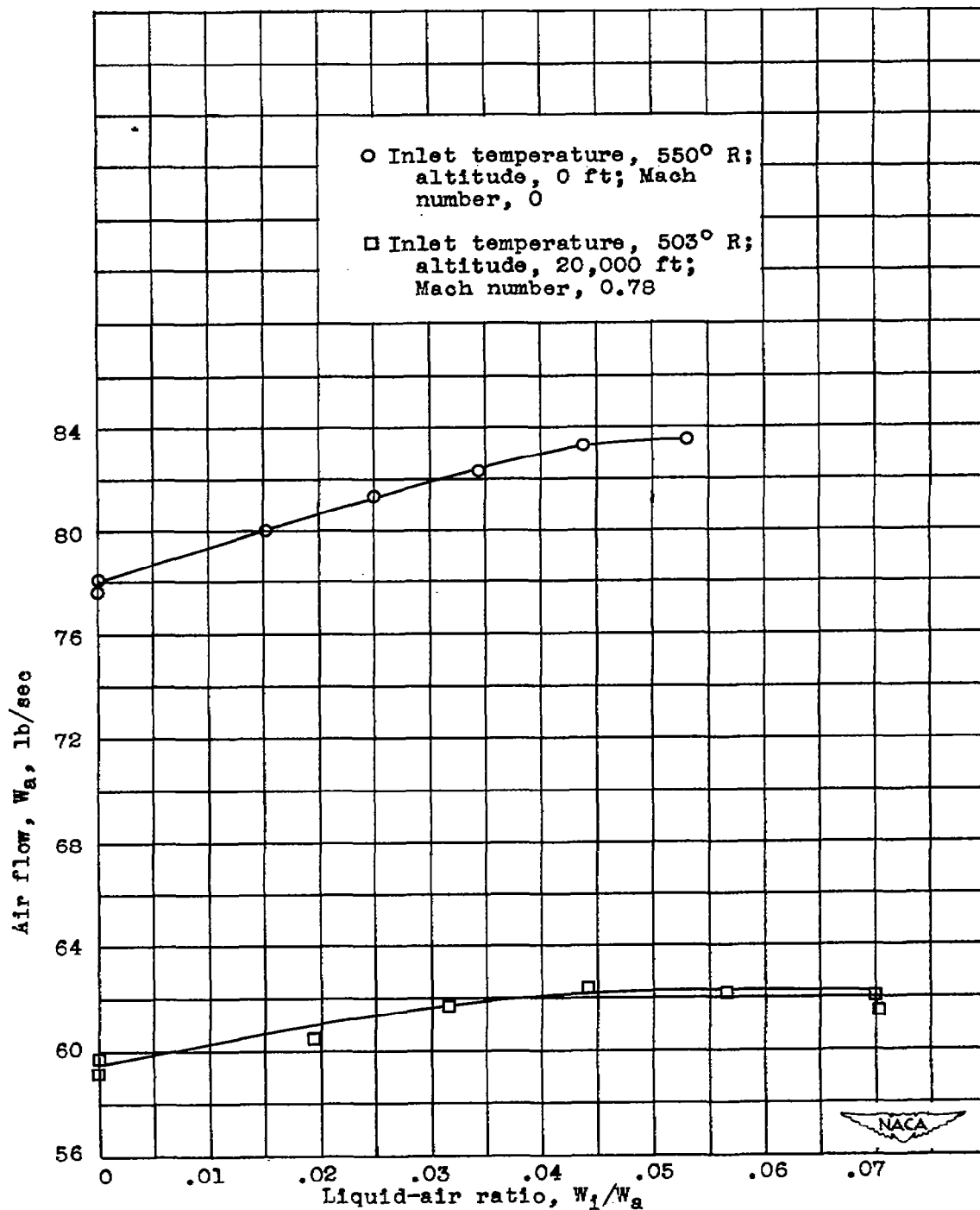

Figure 5. - Air flow as function of liquid-air ratio. Rated engine speed, 11,750; water-alcohol ratio, 2:1.

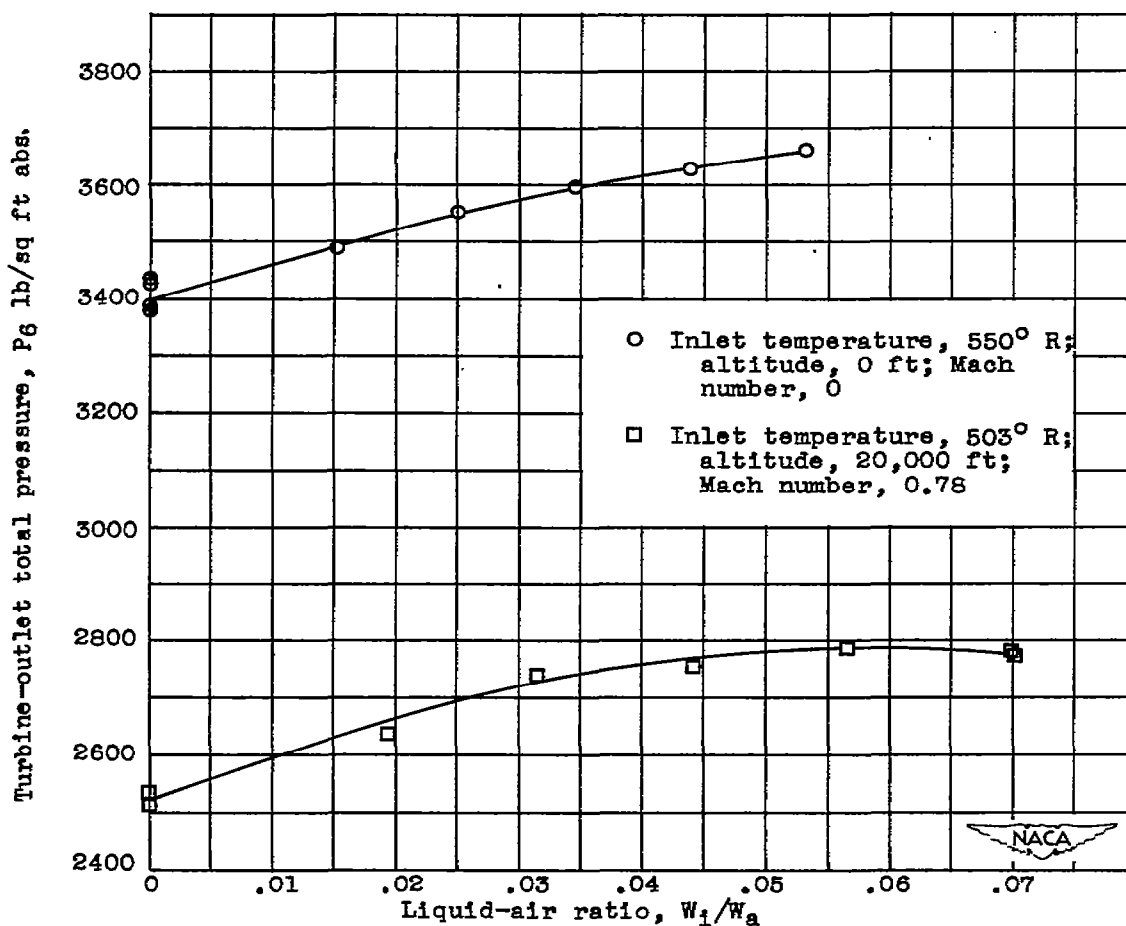
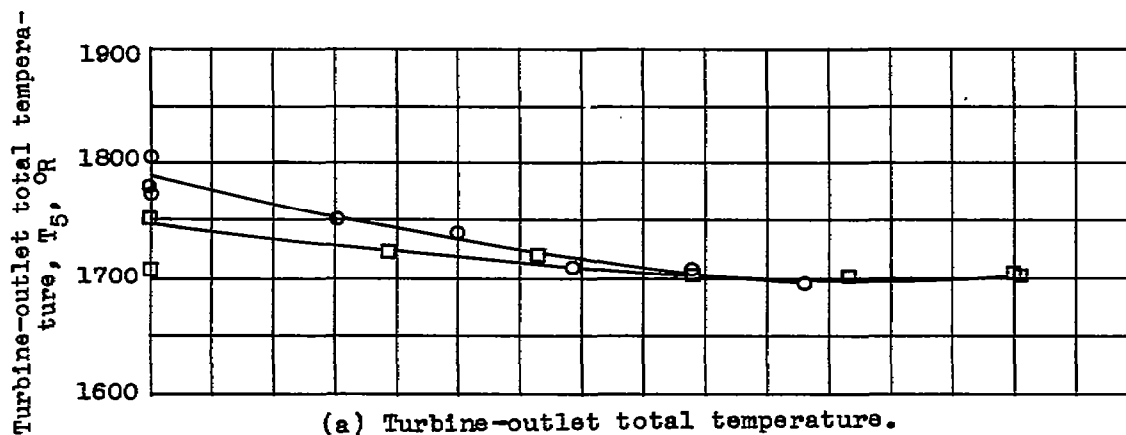
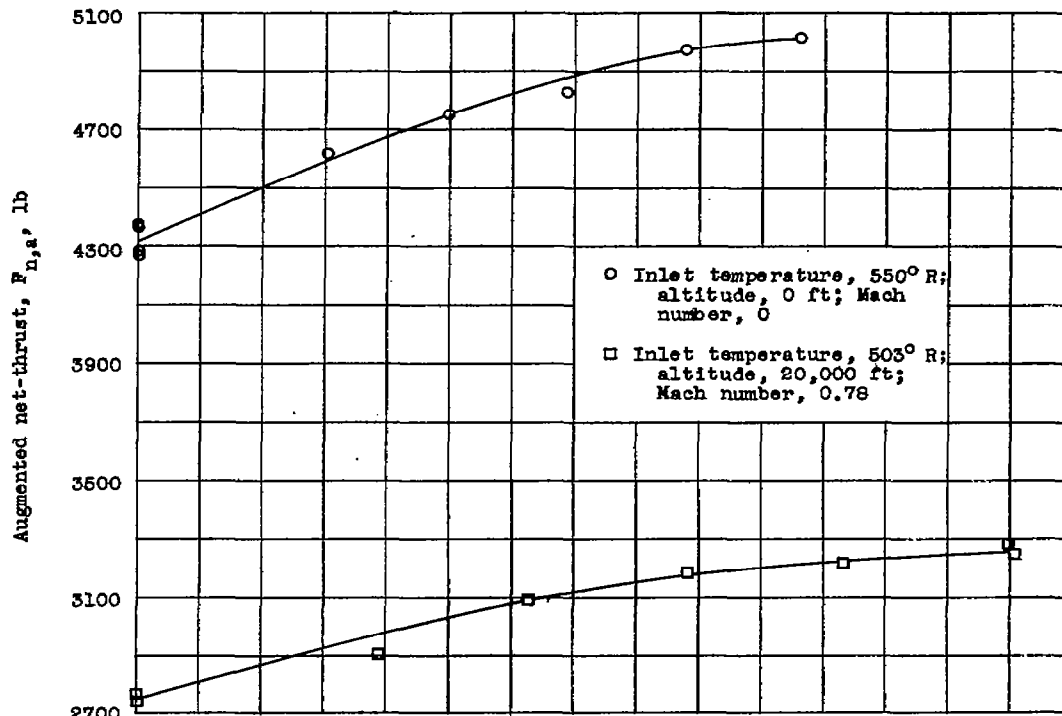
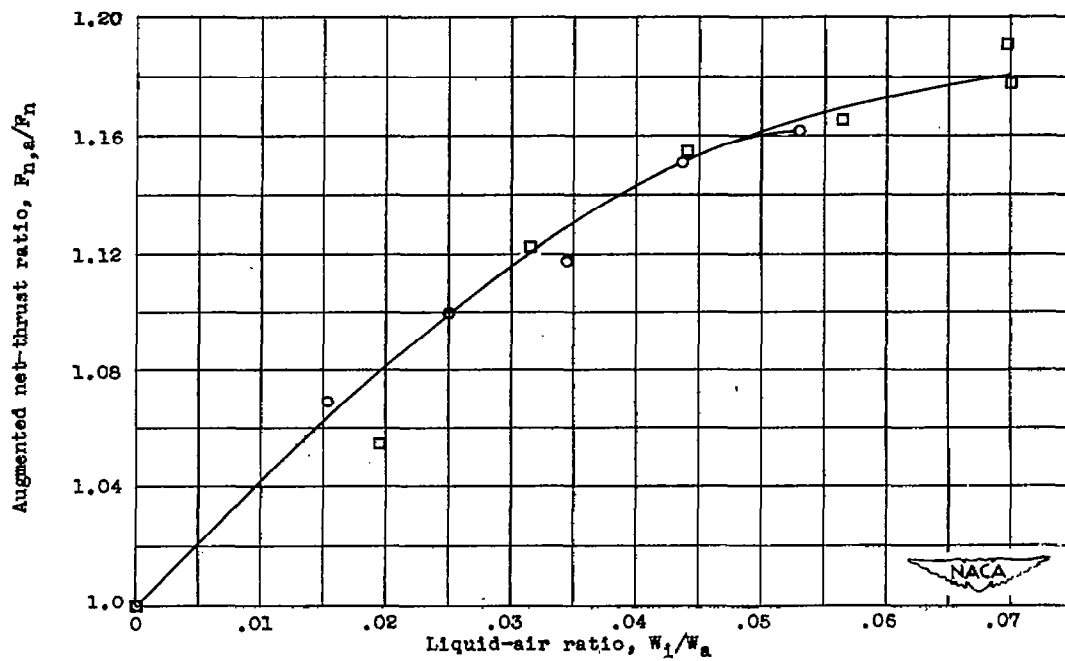

Figure 6. - Turbine-outlet total pressure and temperature as function of liquid-air ratio. Rated engine speed, 11,750; water-alcohol ratio, 2:1.



(a) Augmented net-thrust.



(b) Augmented net-thrust ratio.

Figure 7. - Thrust as function of liquid-air ratio. Rated engine speed, 11,750;
water-alcohol ratio, 2:1.

1389

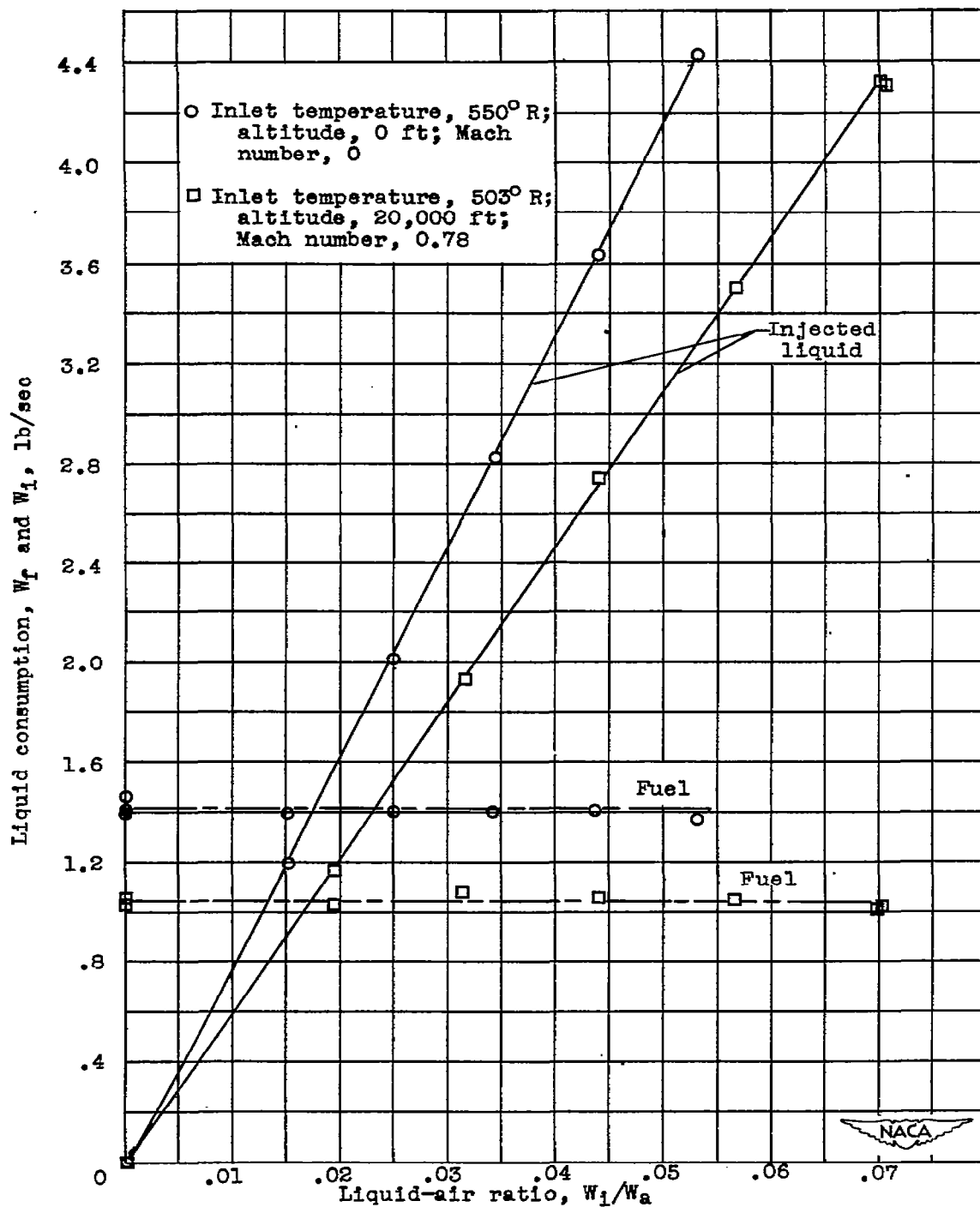

Figure 8. - Variation of fuel flow and injected liquid with liquid-air ratio. Rated engine speed, 11,750; water-alcohol ratio, 2:1.

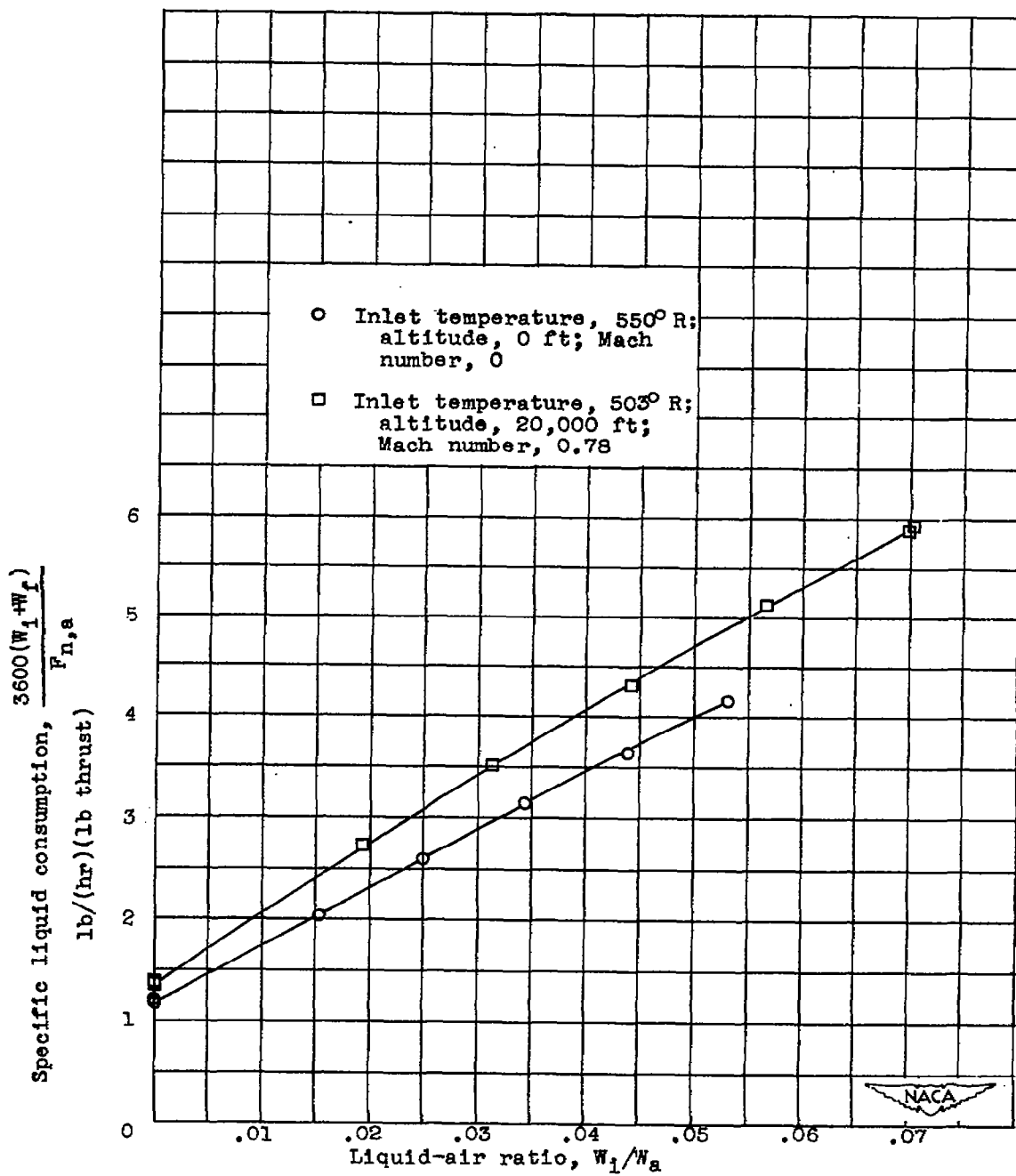

Figure 9. - Specific liquid consumption as function of liquid-air ratio. Rated engine speed, 11,750; water-alcohol ratio, 2:1.

NASA Technical Library



3 1176 01435 0095