

FILE COPY
NO. 9

RM L50D20

NACA RM L50D20

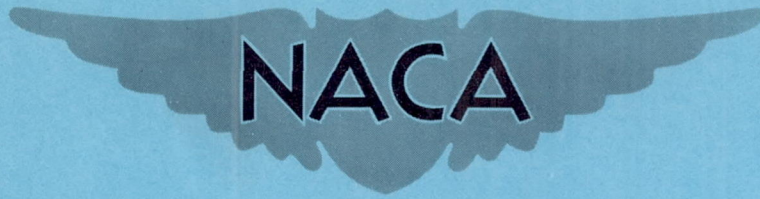

RESEARCH MEMORANDUM

FLIGHT INVESTIGATION OF THE AILERON CHARACTERISTICS OF
THE DOUGLAS D-558-I AIRPLANE (BuAero No. 37972) AT
MACH NUMBERS BETWEEN 0.6 AND 0.89

By Jim Rogers Thompson, William S. Roden,
and John M. Eggleston

Langley Aeronautical Laboratory
Langley Air Force Base, Va.

THIS DOCUMENT ON LOAN FROM THE ~~Langley~~

NATIONAL ADVISORY COMMITTEE FOR AERONAUTICS
LANGLEY AERONAUTICAL LABORATORY
LANGLEY FIELD, HAMPTON, VIRGINIA

RETURN TO THE ~~ADVISORS~~
REQUESTS FOR PUBLICATIONS SHOULD BE ADDRESSED
AS FOLLOWS:

NATIONAL ADVISORY COMMITTEE FOR AERONAUTICS
1512 H STREET, N. W.
WASHINGTON 25, D. C.

NATIONAL ADVISORY COMMITTEE FOR AERONAUTICS

WASHINGTON

May 26, 1950

NATIONAL ADVISORY COMMITTEE FOR AERONAUTICS

RESEARCH MEMORANDUM

FLIGHT INVESTIGATION OF THE AILERON CHARACTERISTICS OF
THE DOUGLAS D-558-I AIRPLANE (BuAero No. 37972) AT
MACH NUMBERS BETWEEN 0.6 AND 0.89

By Jim Rogers Thompson, William S. Roden,
and John M. Eggleston

SUMMARY

Abrupt, rudder-fixed aileron rolls have been made with the Douglas D-558-I airplane (BuAero No. 37972) at Mach numbers between 0.6 and 0.89. Rolls were made at aileron deflections between one-eighth and one-half the maximum available deflection. The results obtained indicate that the aileron effectiveness is independent of Mach number and deflection within the range investigated.

Limited information on the lateral trim and handling qualities of the airplane at high Mach numbers is presented.

INTRODUCTION

As a part of the NACA high-speed flight research program, measurements have been made of the aileron effectiveness of the Douglas D-558-I airplane BuAero No. 37972. Measurements of the directional and longitudinal stability and control characteristics of the D-558-I airplane, BuAero No. 37971, have been reported in references 1 and 2, respectively. The results presented in this paper were obtained during seven flights of the airplane at the NACA High-Speed Flight Research Station, Edwards Air Force Base, California, between May and December 1949.

SYMBOLS

p	rolling angular velocity, radians per second
b	wing span, feet
V	true airspeed, feet per second
M	Mach number
q_c	impact pressure, pounds per square foot
δ_a	change in total aileron deflection, degrees
h	pressure altitude, feet
	aileron wheel force, pounds
w	wing chord, feet

AIRPLANE

The Douglas D-558-I research airplane is a single-place low-wing monoplane powered by a General Electric TG-180 turbojet engine. Detailed specifications of the airplane are given in table I and a three-view drawing and photographs are presented as figures 1 and 2, respectively.

The ailerons are of the plain flap type and have a nominal maximum travel of ± 15 degrees. The contour of the ailerons is specified as a continuation of that of the airfoil; however, the ailerons of airplane No. 37972 are slightly warped. This warpage (measured with no load on the aileron) amounted to as much as 1° variation in the angle between the aileron-chord line and the wing-chord line at different positions along the span of each aileron.

As flown in the tests reported herein, the weight of the airplane at take-off was 10,557 pounds and the center of gravity was at 23.8 percent of the mean aerodynamic chord.

INSTRUMENTATION

Synchronized NACA instruments were used to record time histories of the following quantities:

- Airspeed
- Altitude
- Normal, longitudinal, and transverse accelerations
- Rolling angular velocity
- Aileron, elevator, and rudder positions
- Aileron, elevator, and rudder forces
- Stabilizer incidence
- Yaw angle

The airspeed head and the yaw vane were mounted on booms one chord length ahead of the right and left wing tips, respectively. The airspeed system of the airplane was calibrated by the low-altitude fly-by method and by the radar method of reference 3. All results presented in this paper are corrected for blocking at the airspeed head and for lag in the system.

TESTS

Results presented herein were obtained in abrupt rudder-fixed aileron rolls at various Mach numbers between 0.6 and 0.89. Most of the rolls were made at pressure altitudes of about 35,000 feet, although some were made as low as 15,000 feet. Rolls were made in each direction at approximately one-fourth and one-half the available aileron deflection. For most of the flights a mechanical stop was provided in the cockpit to enable the pilot to hold a constant aileron deflection until a constant value of rolling velocity was reached.

RESULTS AND DISCUSSION

Time histories of typical rolls are shown in figure 3. It may be seen in the time histories that a yawing oscillation is usually present. This condition is most apparent when the rolling velocity is increasing (for example fig. 3(a)) and in most cases damps out as the maximum rolling velocity is reached. A study of a number of rolls was made to determine the effects of yawing upon maximum rolling velocity, but no significant change in maximum rolling velocity was noted.

Aileron effectiveness.- The data obtained in each roll were reduced to the wing-tip helix angle $\frac{pb}{2V}$ and the corresponding change in total aileron deflection δ_a , the values of p and δ_a being taken as the difference between the conditions immediately before the abrupt aileron deflection and the time at which maximum rolling velocity was reached. The variation of the wing-tip helix angle $\frac{pb}{2V}$ with change in total aileron deflection δ_a is presented in figure 4. The Mach numbers of the rolls are indicated in the figure by different symbols. It is evident that the data presented in figure 4 are adequately faired by a straight line and that no systematic variation with Mach number is indicated.

The data are presented in figure 5 as the variation of aileron effectiveness $\frac{pb}{2V}/\delta_a$ with Mach number. In this figure different symbols are used to identify the altitude range in which each roll was made. This plot shows that within the apparently random scatter of the data, $\frac{pb}{2V}/\delta_a$ has a constant value of 0.0033 radian per degree throughout the Mach number range investigated and that the aileron effectiveness is apparently independent of the altitude, although the amount of data obtained at altitudes other than 30,000 to 35,000 feet is limited. Using the faired value of $\frac{pb}{2V}/\delta_a$ and extrapolating to full aileron deflection (± 15 degrees), the maximum value of $\frac{pb}{2V}$ obtainable with this airplane would be 0.099. It is interesting to note that for a full-aileron-deflection roll at a Mach number of 0.85 at 35,000 feet the maximum rolling velocity would be 6.63 radians per second or 1 complete revolution in 0.95 second if the extrapolation to full deflection is valid. Rolls were not made with more than one-half the available aileron deflection at any speed as, in the opinion of the pilot, the rolling velocities obtained at one-half deflection are at least as great as the maximum required for either test or military operation of the airplane.

Aileron forces.- The variation of wheel force measured at the point of maximum rolling velocity with total aileron deflection is given in figure 6. The rolls were made at 6 approximate values of indicated airspeed which are identified by different symbols. The slope of the force-deflection curves is positive and, with minor exceptions which are within the estimated uncertainty of the measurements, the force required at a given deflection increases with increase in the indicated airspeed. Examination of the time histories (fig. 3) shows that the wheel force decreases with time in each roll. Thus, the indicated value of force

at maximum rolling velocity depends to some extent on the time required to reach maximum rolling velocity as well as on the friction in the system. The friction in the aileron control system is of the order of ± 5 pounds.

The force data are presented in figure 7 as the variation of the wheel force divided by the impact pressure with total aileron deflection. By dividing the wheel force by the impact pressure q_c , the data were reduced (except for an apparently random scatter) to approximately a single line, indicating that the total aileron hinge-moment coefficient for a given deflection is independent of Mach number within the range investigated.

Lateral trim and handling characteristics at high Mach numbers.- In addition to the measurements of effectiveness and wheel force presented herein, some supplementary information on the lateral handling qualities of the airplane at high speeds has been obtained. A time history of a typical high-speed run is presented in figure 8 to illustrate the lateral handling qualities of the airplane. As the speed of the airplane is increased a right-wing heaviness becomes apparent to the pilot at about the same time as general buffeting of the airplane is encountered ($M \approx 0.85$; 16 seconds). As the speed is further increased the wing heaviness increases, a change in aileron trim force of about 7 pounds and a corresponding change in total aileron deflection of about one-half degree being required to trim in the case shown in figure 8 at a Mach number of about 0.88. The trim force and deflection for the wing-heaviness example quoted are typical, although in a few cases trim changes could not be detected on the recording instruments and were not noticeable to the pilot. The lateral unsteadiness of the airplane at high speeds is evident on the time history from the rapid variations of force and deflection applied by the pilot in attempting to trim. It is also evident from figure 8 that the airplane has a short-period rolling-yawing oscillation of small amplitude. In addition to the wing heaviness, pilots have reported an intermittent "wing dropping" which occurs above a Mach number of about 0.86. This sudden rolling of the airplane occurs in either direction and appears to be associated with the general lateral unsteadiness of the airplane at high Mach number.

The wing heaviness encountered in the D-558-I airplane is similar to that reported for the X-1 airplane in reference 4. In the X-1, the wing heaviness begins to be apparent at about $M = 0.85$ and appears to be associated with the abrupt reduction in aileron effectiveness which occurs as the Mach number is increased above 0.85. The results presented herein for the D-558-I airplane show that the aileron effectiveness does not decrease up to $M = 0.89$. It should be noted, however, that the effectiveness has not been investigated for small deflections.

A possible contributing cause of both the wing heaviness and wing dropping is the probable asymmetric location and movement of shock waves on the wing resulting from construction asymmetry.

CONCLUDING REMARKS

Results obtained in rudder-fixed aileron rolls of the Douglas D-558-I airplane (BuAero No. 37972) at Mach numbers between 0.6 and 0.89 indicated that within the range investigated the aileron effectiveness is independent of Mach number.

Langley Aeronautical Laboratory
National Advisory Committee for Aeronautics
Langley Air Force Base, Va.

REFERENCES

1. Williams, Walter C.: Flight Measurement of the Stability Characteristics of the Douglas D-558-1 Airplane (BuAero No. 37971) in Sideslips. NACA RM L8E14a, 1948.
2. Barlow, William H., and Lilly, Howard C.: Stability Results Obtained with Douglas D-558-1 Airplane (BuAero No. 37971) in Flight Up to a Mach Number of 0.89. NACA RM L8K03, 1948.
3. Zalovcik, John A.: A Radar Method of Calibrating Airspeed Installations on Airplanes in Maneuvers at High Altitudes and at Transonic and Supersonic Speeds. NACA TN 1979, November 1949.
4. Drake, Hubert M., McLaughlin, Milton D., and Goodman, Harold R.: Results Obtained during Accelerated Transonic Tests of the Bell XS-1 Airplane in Flights to a Mach Number of 0.92. NACA RM L8A05a, 1948.

TABLE I

PHYSICAL CHARACTERISTICS OF DOUGLAS D-558-I AIRPLANE

Wing:

Area, sq ft	150.7
Span, ft	25
Taper ratio	0.54
Aspect ratio	4.17
Root section	NACA 65-110
Tip section	NACA 65-110
Sweepback of 50-percent chord line	0
Geometric dihedral, deg	4.0
Incidence at root chord, deg	2.0
Geometric twist	0
Mean aerodynamic chord, ft	6.21

Ailerons:

Area aft hinge line (both ailerons), sq ft	7.94
Mean aerodynamic chord, ft	0.772
Span (one side), ft	5.19
Hinge-line location (percent c_w)	85

Horizontal tail:

Area, sq ft	35.98
Span, ft	12.25
Aspect ratio	4.17
Taper ratio	0.55
Tail length, from $0.25c_w$ to elevator hinge line, ft	16.34

Elevators:

Area aft of hinge line (both sides), sq ft	8.6
Span (one side), ft	5.91
Hinge location, percent horizontal-tail chord	75
Mean aerodynamic chord, ft	0.75

Vertical tail surface:

Area, sq ft	25.68
Span, ft	5.55
Aspect ratio	1.20
Taper ratio	0.56
Fin offset	0
Tail length, from $0.25c_w$ to rudder hinge line, ft	17.38
Dorsal-fin area, sq ft	9.08

TABLE I

PHYSICAL CHARACTERISTICS OF DOUGLAS D-558-I AIRPLANE - Concluded

Rudder:

Area aft of hinge line, sq ft	7.92
Span, ft	5.67
Mean aerodynamic chord, ft	1.44

Fuselage:

Fuselage length, ft	35.04
Fuselage depth (maximum), ft	4.0
Fuselage width (maximum), ft	4.0



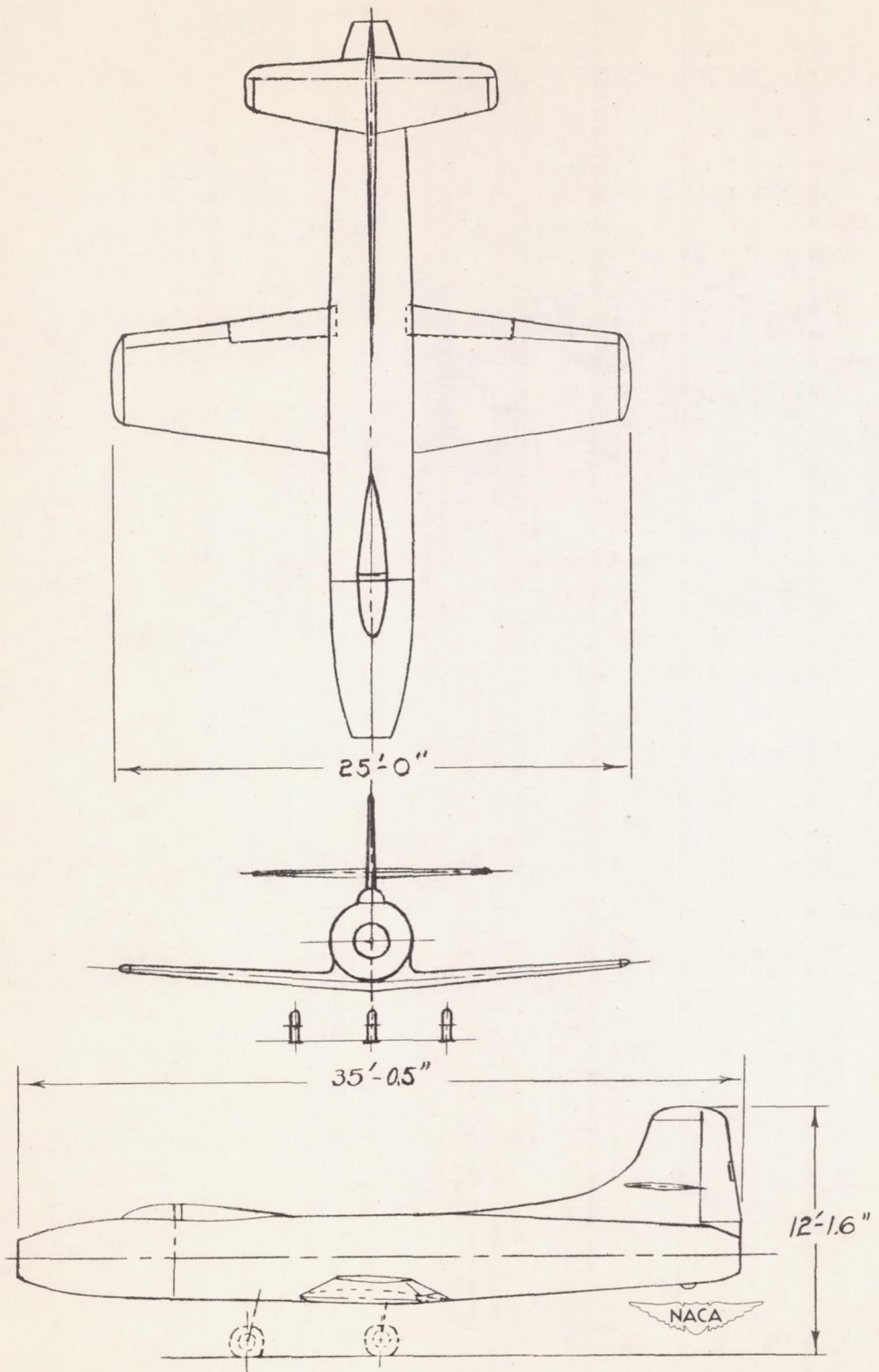
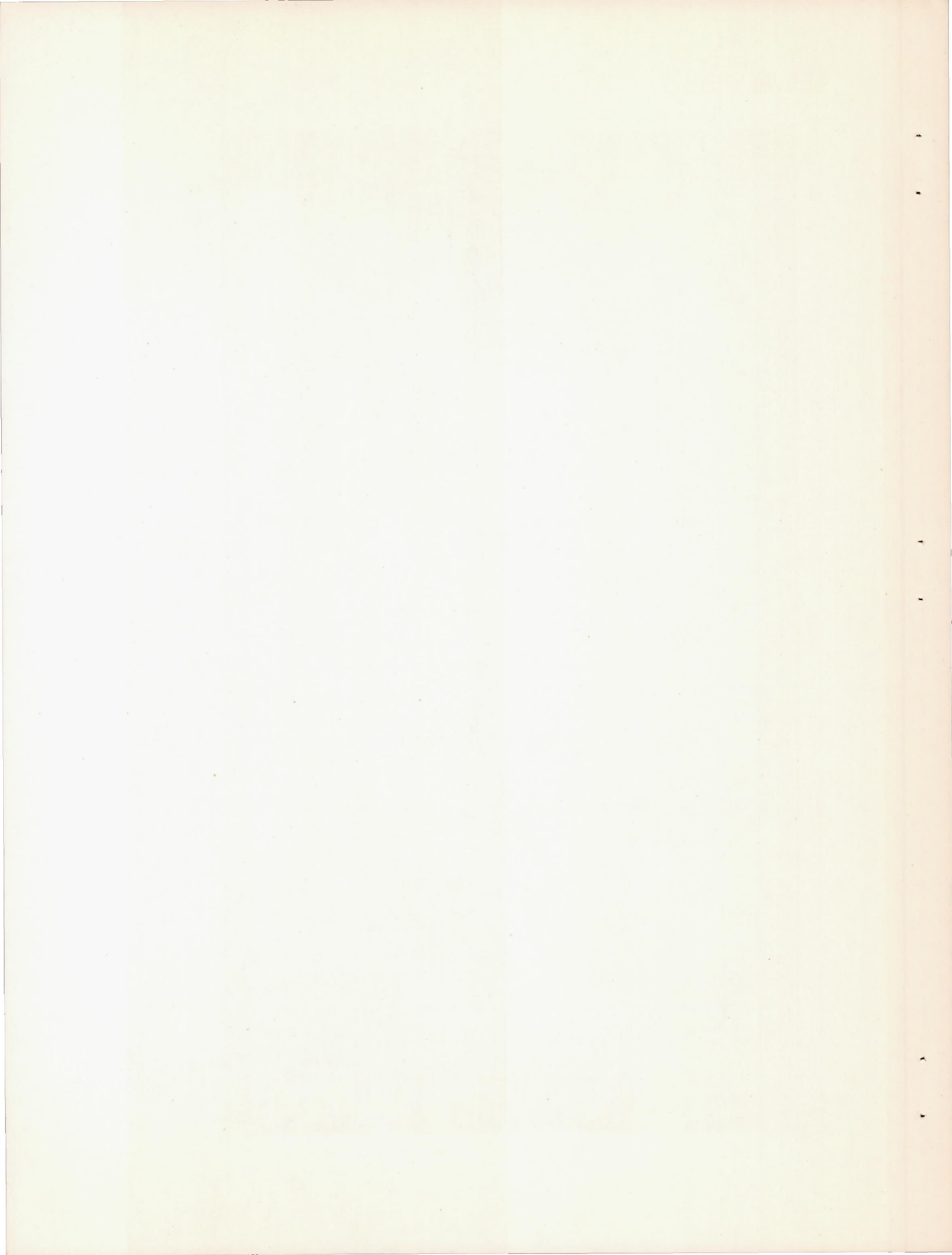
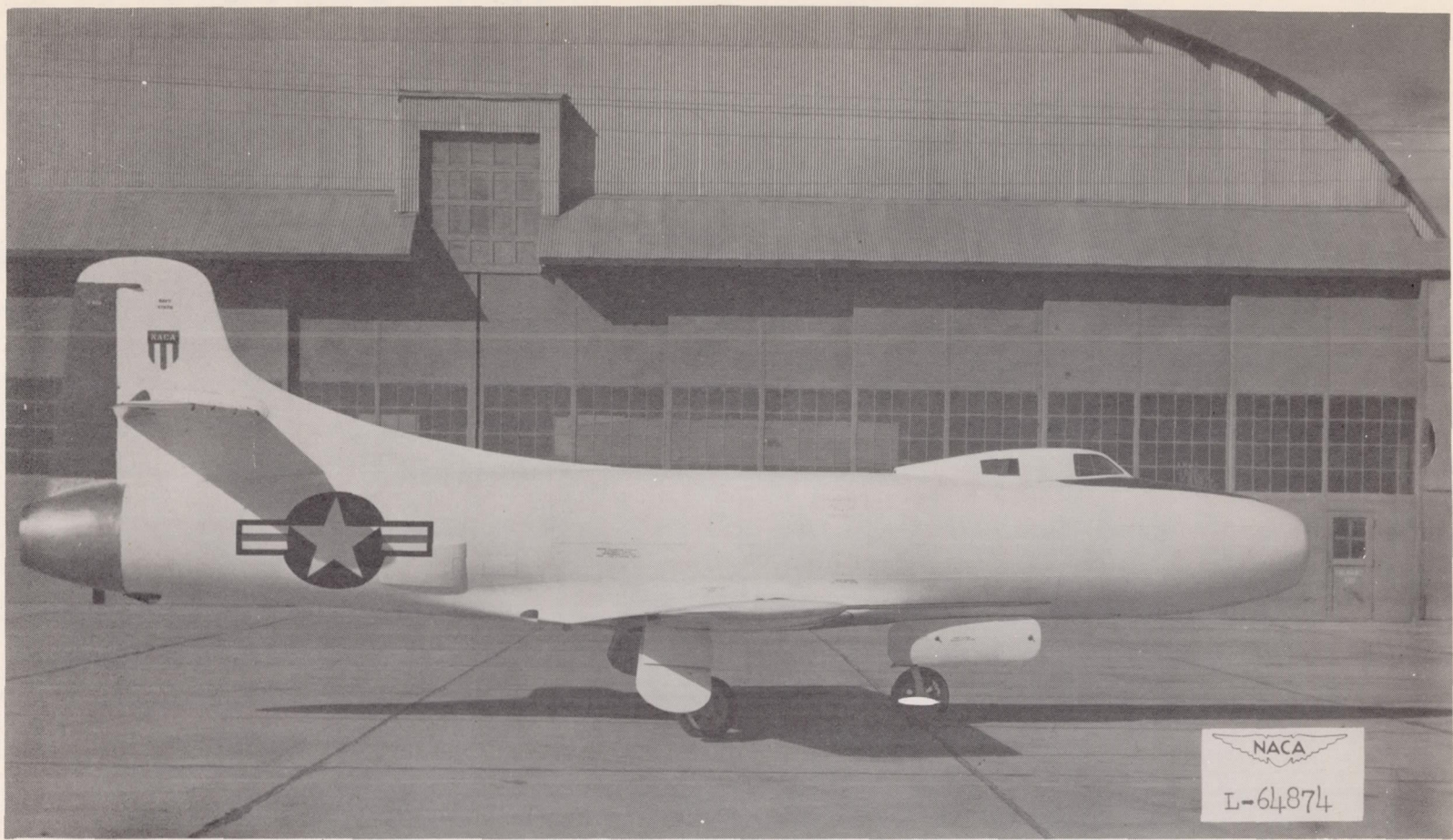

Figure 1.- Three-view drawing of the Douglas D-558-I airplane





(a) Sideview.

Figure 2.- Photographs of the Douglas D-558-I airplane.



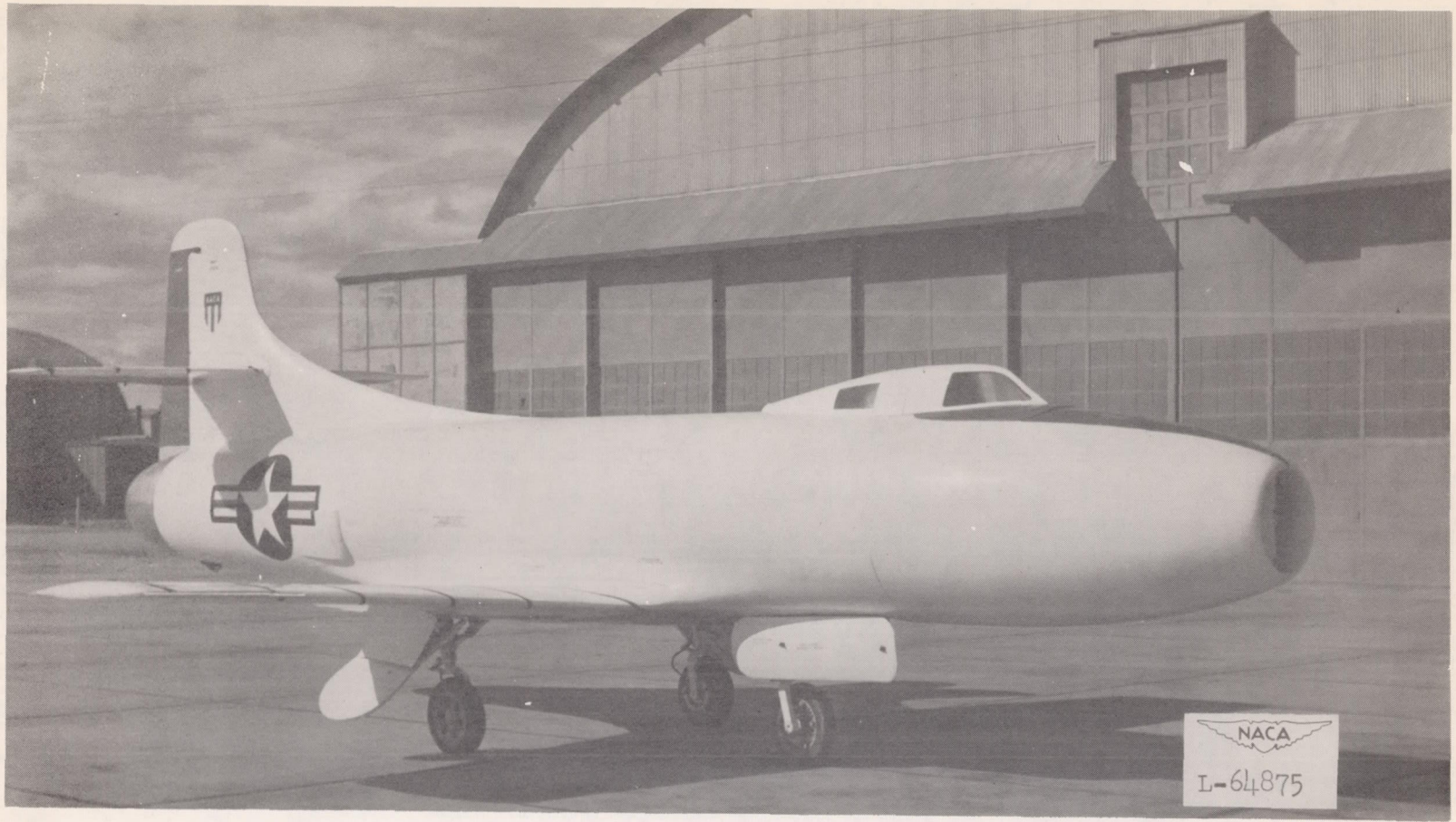

(b) Three-quarter front view.

Figure 2.- Continued.

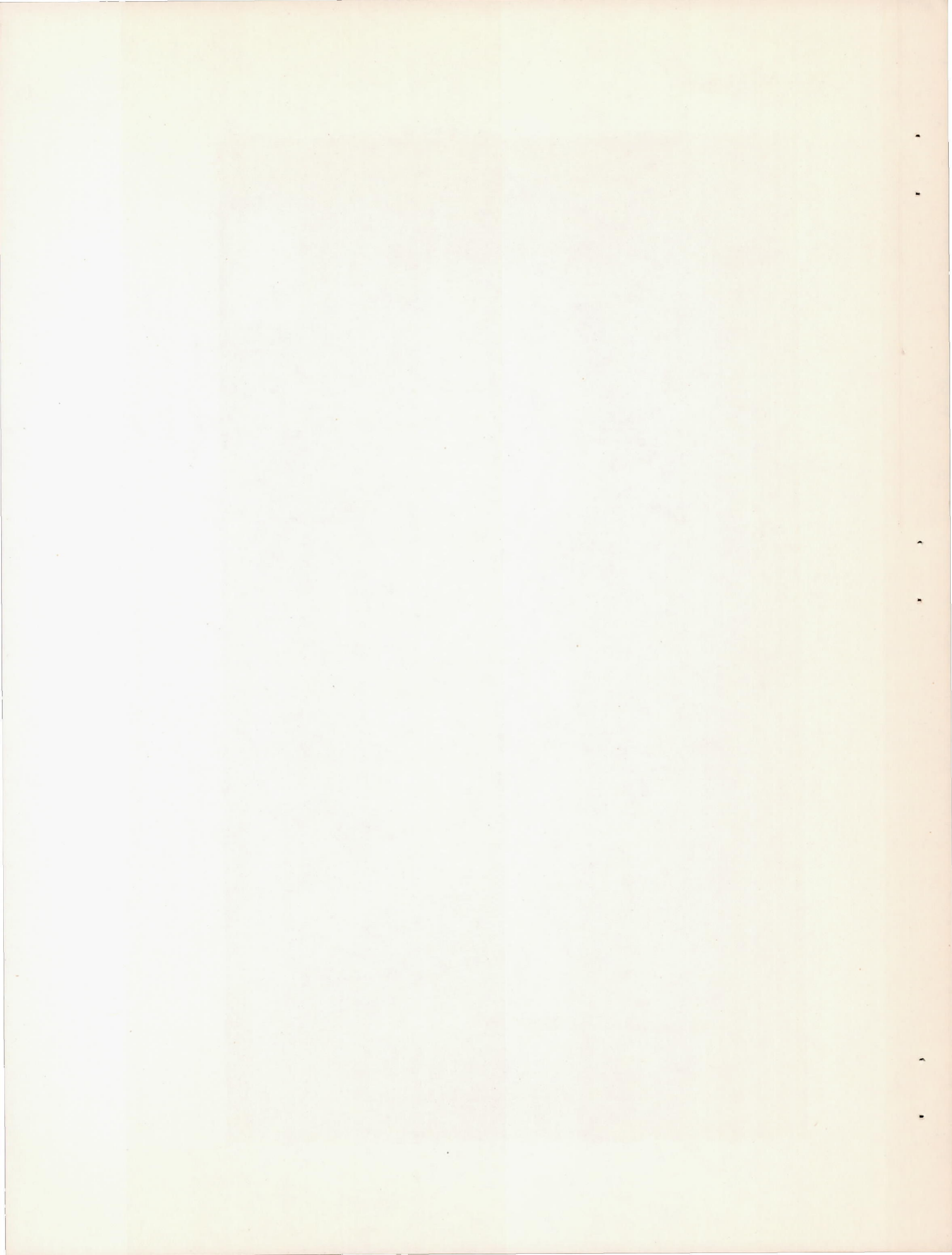

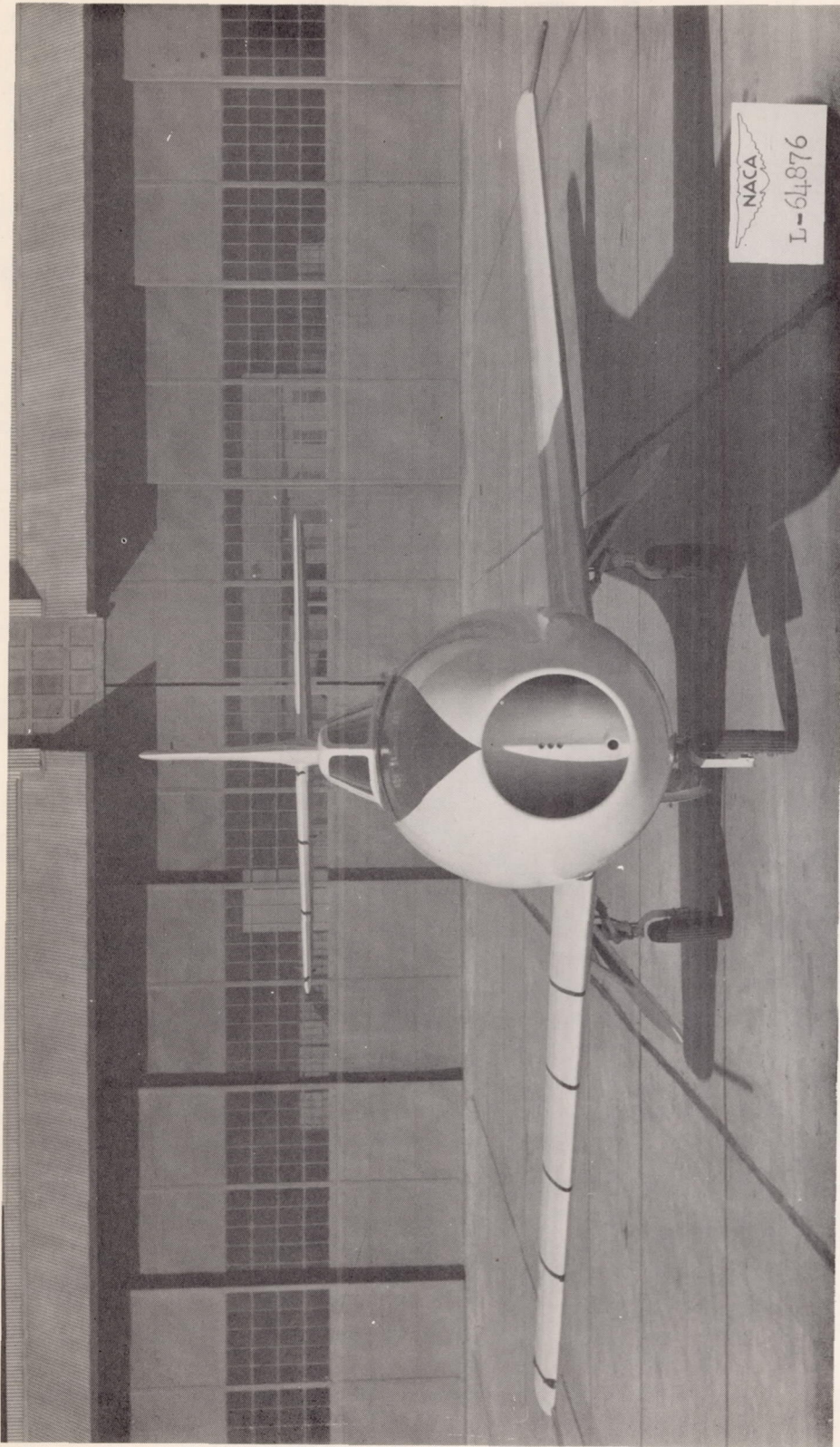

(c) Front view.

Figure 2.- Concluded.

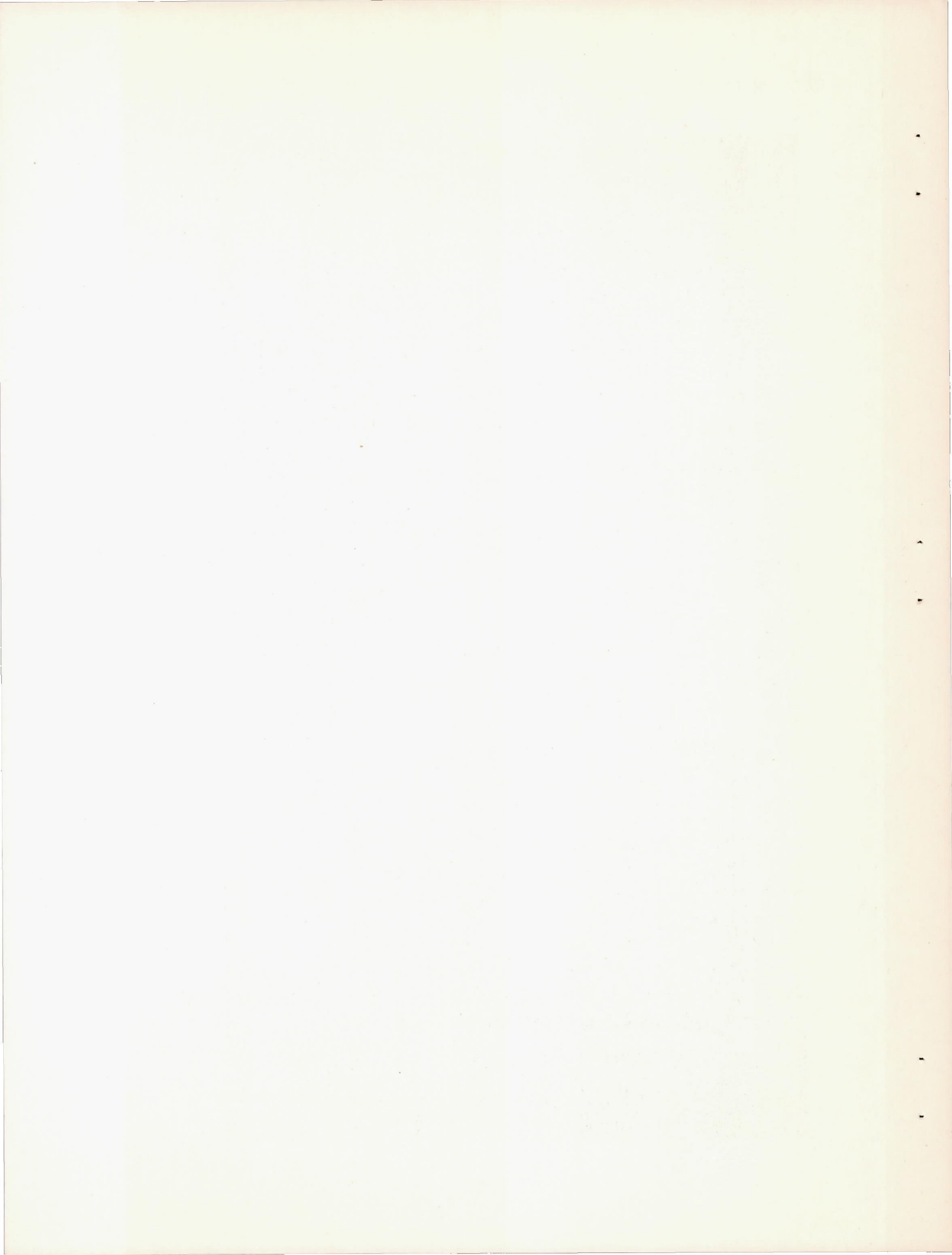

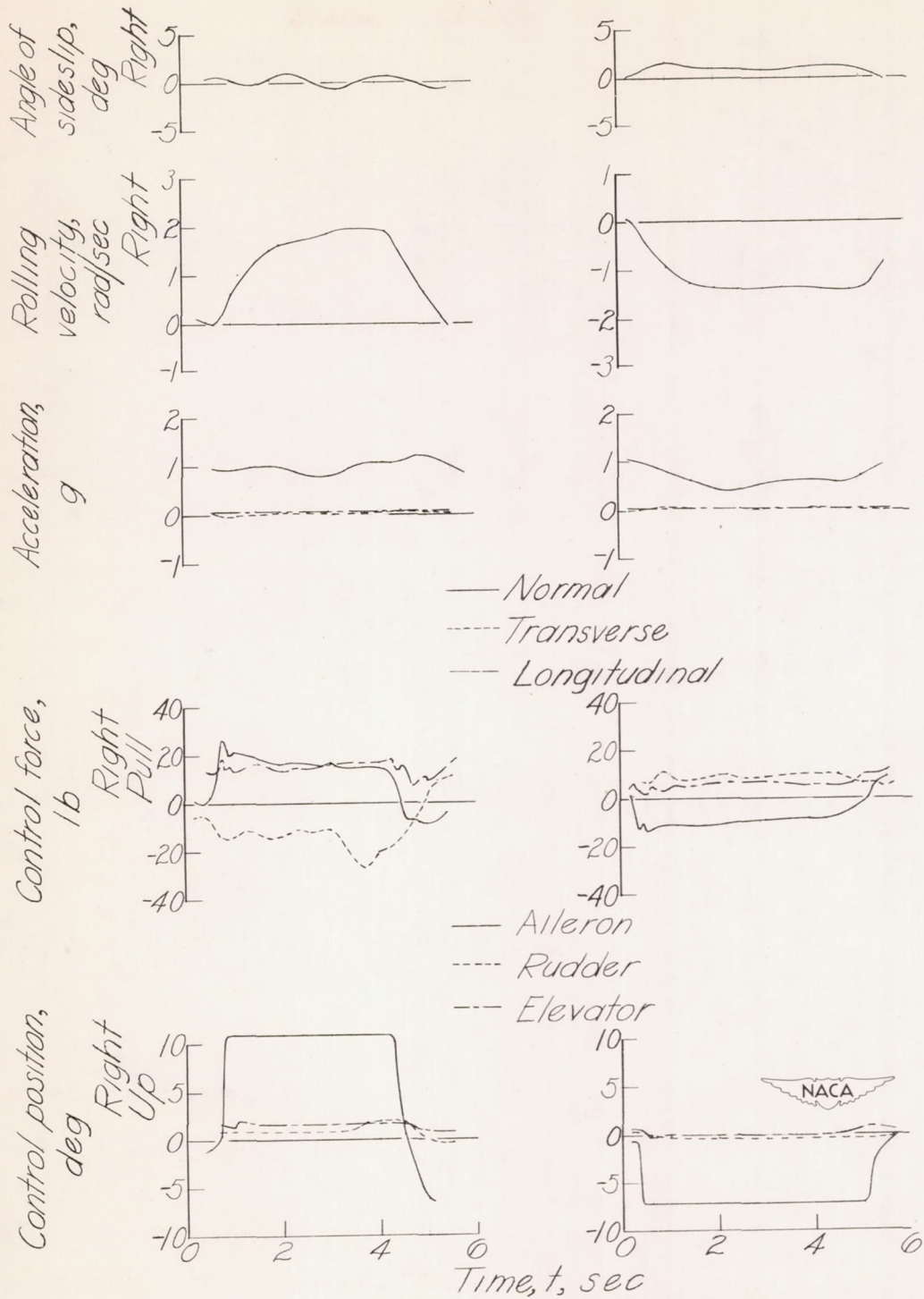

(a) $M=0.61$; $H=33,000$ ft.

(b) $M=0.71$; $H=32,000$ ft.

Figure 3.- Time histories of typical aileron rolls with the Douglas D-558-I airplane.

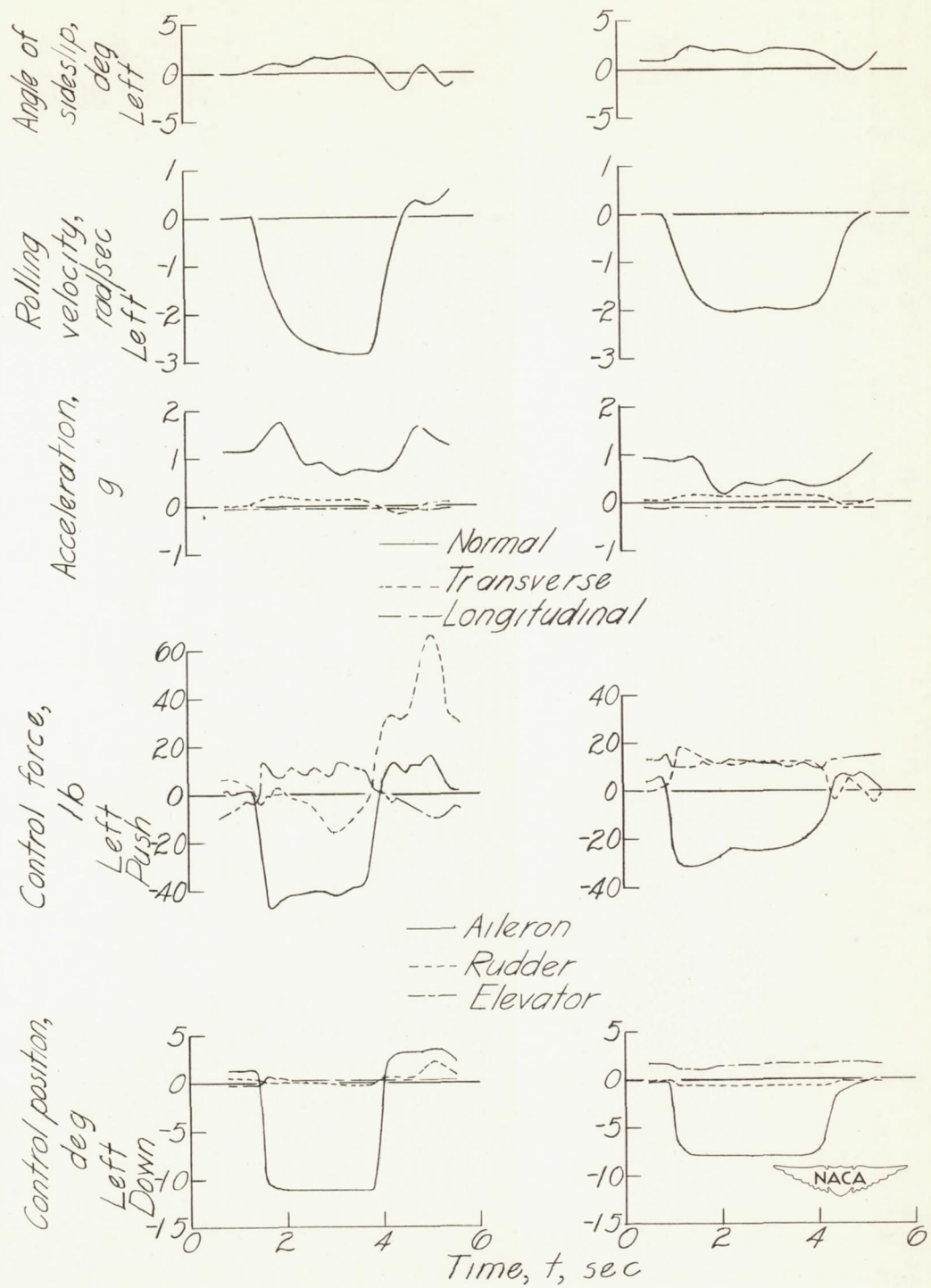

(c) $M=0.82$; $H=24,000$ ft

(d) $M=0.87$; $H=23,000$ ft

Figure 3.- Concluded.

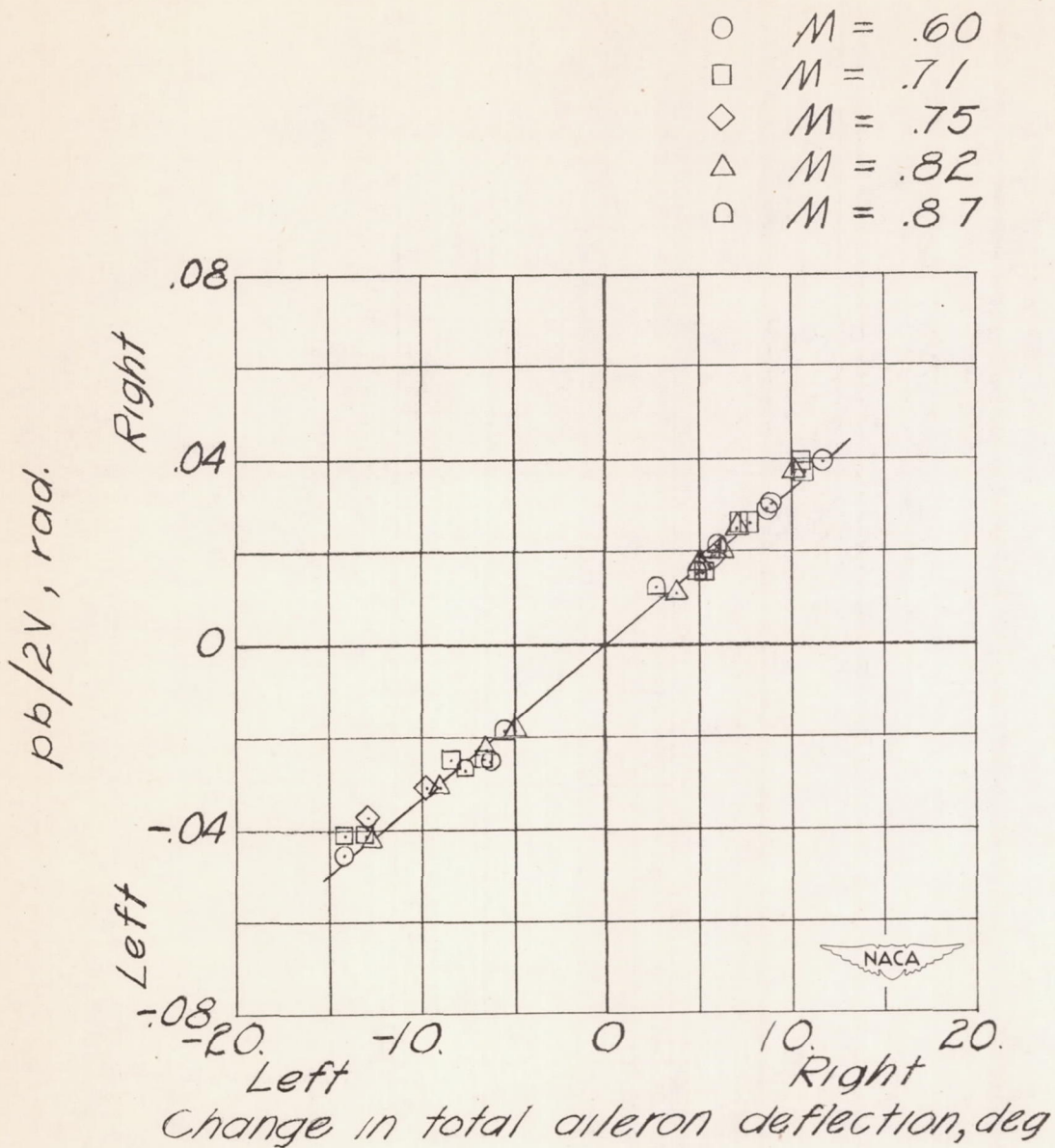

Figure 4.- Variation of wing-tip helix angle $\frac{pb}{2v}$ with change in total aileron deflection as measured in abrupt rudder-fixed aileron rolls.

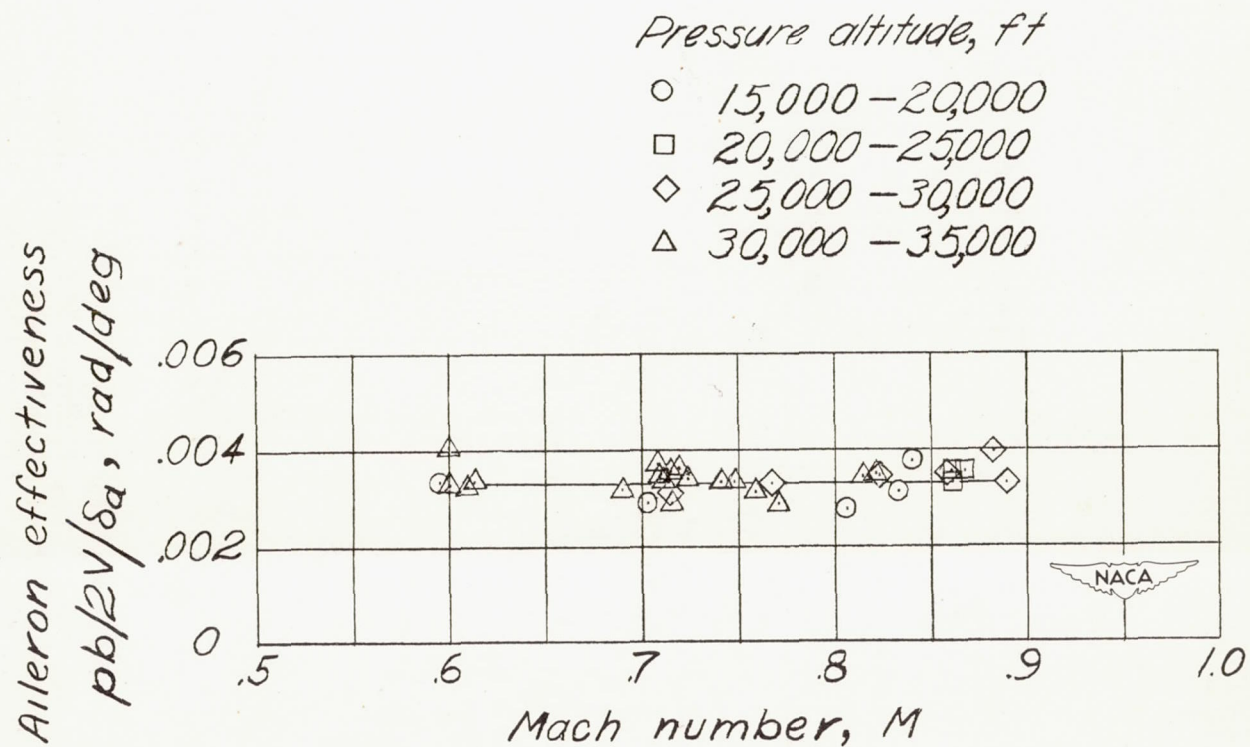

Figure 5.- Variation with Mach number of aileron effectiveness $\frac{pb}{2V}/\delta_a$ for the Douglas D-558-I airplane.

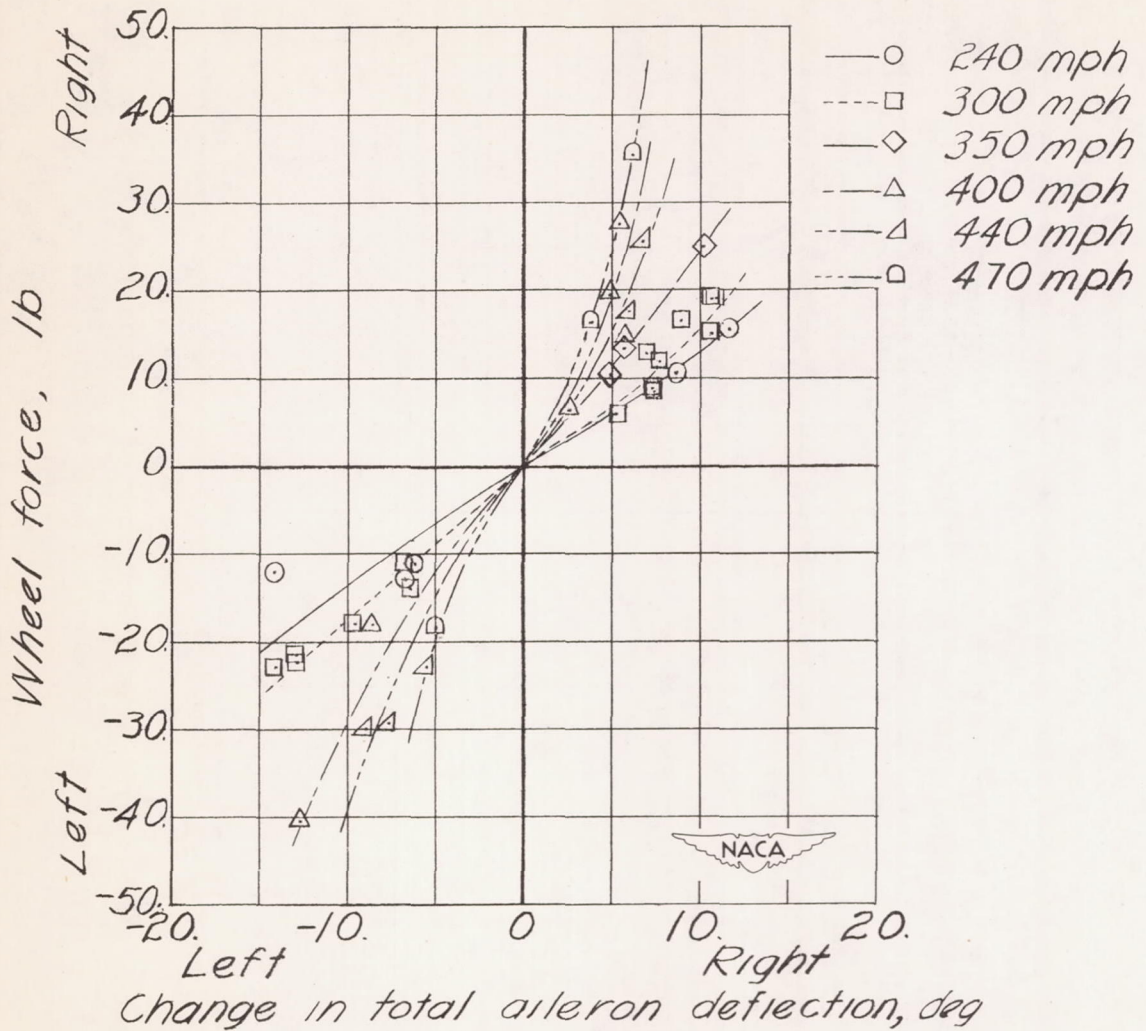

Figure 6.- Variation of wheel force with total aileron deflection for several indicated airspeeds.

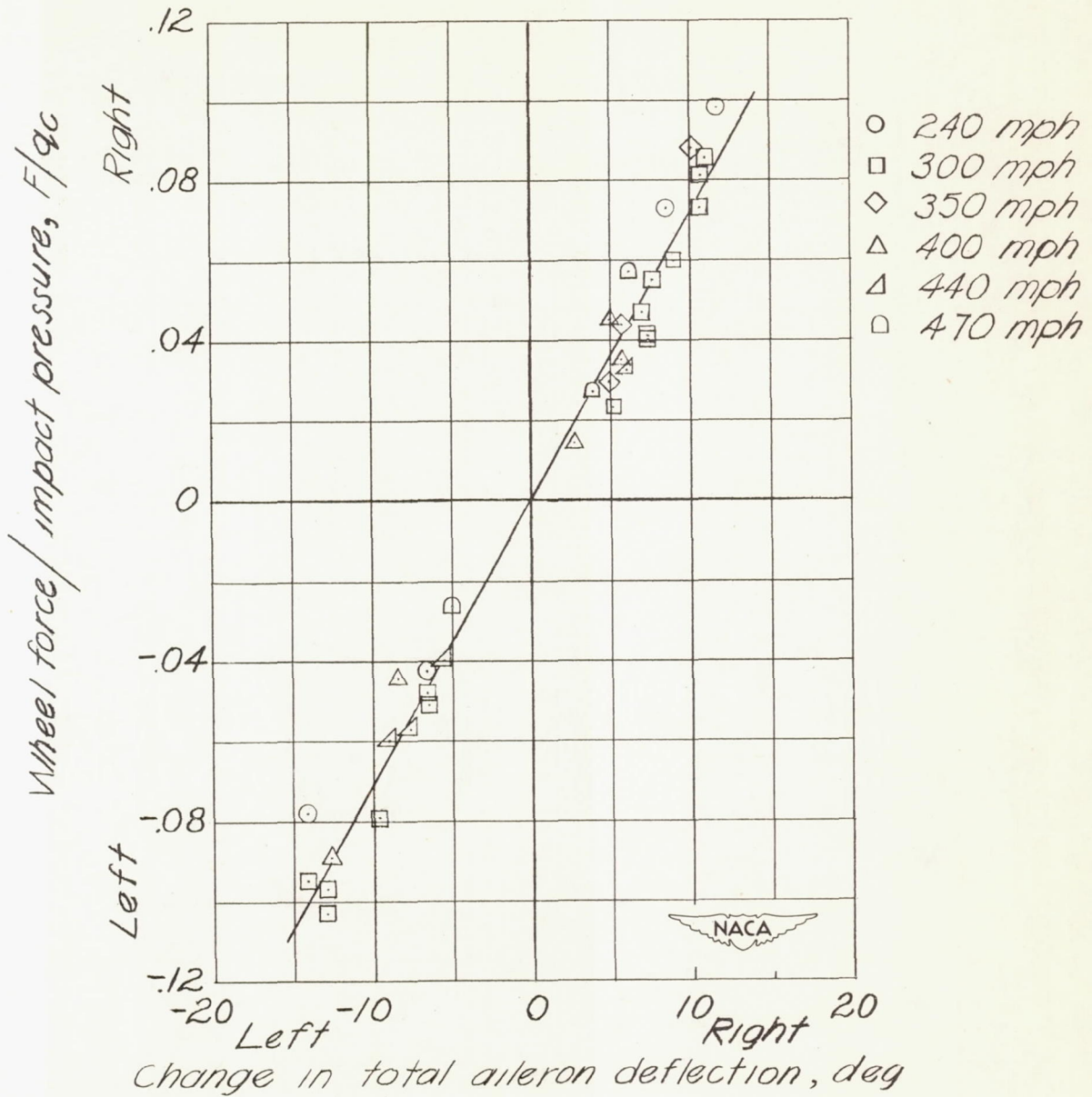

Figure 7.- Variation of wheel force divided by impact pressure with total aileron deflection.

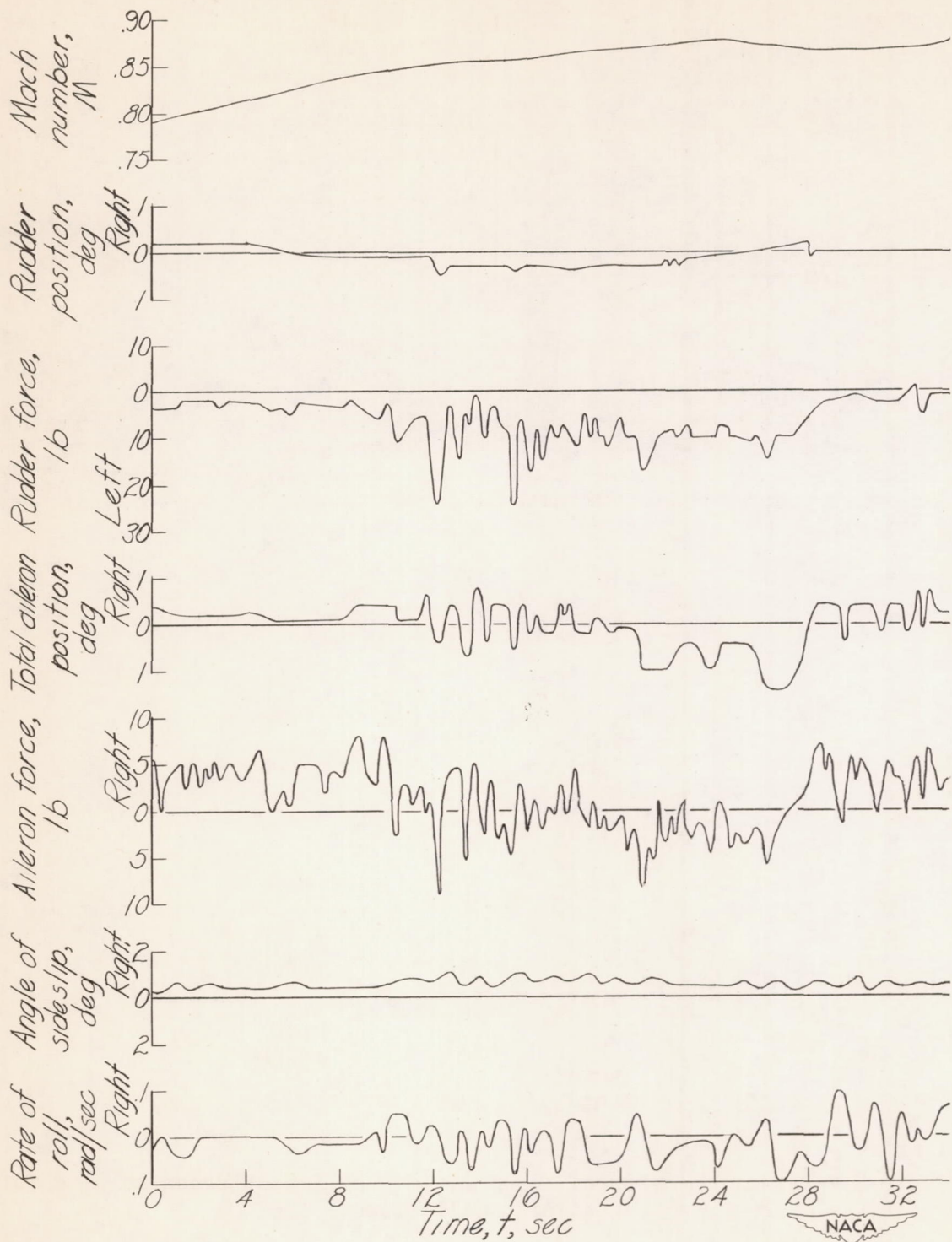

Figure 8.- Time history of a typical high-speed run of the D-558-I airplane, altitude 34,000 to 29,000 feet.