

RM L50I06a

NACA RM L50I06a



RESEARCH MEMORANDUM

DETERMINATION OF LONGITUDINAL STABILITY OF THE
BELL X-1 AIRPLANE FROM TRANSIENT RESPONSES

AT MACH NUMBERS UP TO 1.12 AT LIFT

COEFFICIENTS OF 0.3 AND 0.6

By Ellwyn E. Angle and Euclid C. Holleman

Langley Aeronautical Laboratory
Langley Air Force Base, Va.

NATIONAL ADVISORY COMMITTEE
FOR AERONAUTICS

WASHINGTON

November 7, 1950
Declassified September 17, 1958

NATIONAL ADVISORY COMMITTEE FOR AERONAUTICS

RESEARCH MEMORANDUM

DETERMINATION OF LONGITUDINAL STABILITY OF THE
BELL X-1 AIRPLANE FROM TRANSIENT RESPONSES

AT MACH NUMBERS UP TO 1.12 AT LIFT

COEFFICIENTS OF 0.3 AND 0.6

By Ellwyn E. Angle and Euclid C. Holleman

SUMMARY

A number of free-flight transient responses resulting from small stabilizer movements were obtained during flight tests of the Bell X-1 airplane (8-percent-thick wing and 6-percent-thick tail). Responses were analyzed to obtain a measure of the longitudinal stability characteristics of the airplane over the Mach number range from 0.72 to 1.12 at lift coefficients of 0.3 and 0.6.

The data presented indicate three significant features: (1) The damping varies greatly with Mach number, maximum damping occurring at Mach numbers of 0.82 and 1.08 and a minimum damping at about 0.93; (2) some uncertainty of damping between Mach numbers of 0.91 to 0.95 appears although good agreement with model tests exists throughout the Mach number range covered; and (3) the static stability of the airplane increases with Mach number to a Mach number of about 0.93 and decreases with further increasing Mach number. Data above a Mach number of 0.90 indicate some lift-coefficient effects. Agreement of the full-scale flight data and model data over the Mach number range is good.

INTRODUCTION

During the course of the flight tests of the Bell X-1 airplane a number of airplane responses to small stabilizer movements were obtained and have been analyzed using the transient-response analysis to determine the longitudinal-stability derivatives of the airplane. It may be pointed out that tests specific for the application of the transient-response analysis were not made, but existing data were selected for analysis after considering conditions such as fixed controls and constant Mach number and altitude.

Values for the damping derivatives and the static-stability derivatives have been obtained over a range of Mach numbers from 0.72 to 1.12 at lift coefficients of approximately 0.3 and 0.6.

The data presented are for the Bell X-1 airplane with an 8-percent-thick wing and a 6-percent-thick tail. A more complete investigation will be conducted on the Bell X-1 airplane with a 10-percent-thick wing and an 8-percent-thick tail under controlled conditions over as wide a range of Mach numbers and lift coefficients as possible.

SYMBOLS

V	forward velocity, feet per second
M	Mach number
q	pitching velocity, radians per second
I_y	mass moment of inertia about Y-axis, slug-feet ²
α	angle of attack, degrees or radians
$\dot{\alpha}$	rate of change of angle of attack, radians per second
g	acceleration due to gravity, 32.2 feet per second per second
q	dynamic pressure, pounds per square feet
c	mean geometric chord, feet
m	mass of airplane, slugs
S	wing area, square feet
S_t	horizontal-tail area, square feet
l_t	tail length, feet
δ_e	elevator deflection, degrees, trailing edge up is negative
ρ	air density, slugs per cubic foot
n	normal acceleration, g units
P	period of oscillation, seconds

H	pressure altitude, feet
t	time, seconds
$T_{1/2}$	time to damp to one-half amplitude, seconds
C_L	lift coefficient (Lift/qS)
$C_{L\alpha}$	rate of change of lift coefficient with angle of attack ($\partial C_L / \partial \alpha$)
C_{m_q}	rate of change of pitching-moment coefficient with pitching-velocity parameter, per degree $\left(\frac{\partial C_m}{\partial \frac{qc}{2V}} \right)$
$C_{m\alpha}$	rate of change of pitching-moment coefficient with angle of attack, per degree
i_t	stabilizer incidence, degrees
σ_1	amplitude of oscillation at $t = t_1$
σ_2	amplitude of oscillation at $t = t_2$
$\Delta t = t_2 - t_1$	
w	natural frequency of free oscillation, radians per second ($2\pi/P$)
$C_{m_{D\alpha}}$	rate of change of pitching-moment coefficient with rate-of-change-of-angle-of-attack parameter, per degree $\left(\frac{\partial C_m}{\partial \frac{d\alpha}{dt}} \right)$

AIRPLANE AND TEST PROCEDURES

Airplane

A three-view sketch of the Bell X-1 research airplane (8-percent-thick wing and 6-percent-thick tail) is presented as figure 1. The physical characteristics as used in the analysis are as follows:

m (empty)	230
S	130
S _t	26
l _t	13.3
c	4.81
I _y	12,350

The moment of inertia about the transverse axis was determined experimentally for an empty weight condition by oscillating the airplane as a single-degree-of-freedom system. An inertia correction was estimated for various weights corresponding to loaded conditions during power-on responses.

A more complete description of the airplane can be found in reference 1.

Instrumentation

Quantities measured necessary to the determination of the longitudinal-stability derivatives of the X-1 airplane are normal acceleration, air-speed, altitude, pitching velocity, angle of attack, and elevator and stabilizer positions. Standard NACA recording instruments were used and were synchronized with a common timer.

Test Procedure

The data presented were analyzed from flight test data obtained during climbs to maximum altitude covering an altitude range of 32,000 to 64,000 feet and a Mach number range from 0.72 to 1.12. The transient oscillations analyzed resulted from a change in stabilizer position necessary for airplane trim during altitude climbs. (The pilot made no attempt to maintain completely a constant elevator position as would be done in a specific program for obtaining transient oscillations.) In most instances the stabilizer was actuated for a change in position of approximately 1° (not from the same initial position) at a rate of 1.83 degrees per second.

Method of Analysis

In dynamic analysis several assumptions must be realized in applying the various expressions for determining the longitudinal-stability derivatives. A two-degree-of-freedom system is assumed involving constant values for the forward velocity, altitude, and control position during the transient subsidence which consists of two or more complete cycles. The expressions for the longitudinal-stability derivatives derived from

a two-degree-of-freedom system similar to the derivatives in reference 2 are as follows:

$$C_{m\alpha} = - \frac{I_y}{57.3qSc} \left[\left(\frac{2\pi}{P} \right)^2 + \left(\frac{0.693}{T_{1/2}} \right)^2 \right] \quad (1)$$

$$C_{mq} + C_{mD\alpha} = \frac{4I_y V}{57.3qSc^2} \left[\frac{0.693}{T_{1/2}} + \frac{57.3C_{L\alpha} qS}{2mV} \right] \quad (2)$$

The term $-\frac{C_{L\alpha} C_{mq} (Sc)^2}{8mI_y}$ is omitted from equation (1) since its numerical value is small compared with the frequency term $(2\pi/P)^2$.

The initial step in the analysis of a given transient oscillation is graphical in that the oscillation is enclosed in an envelope formed by lines connecting the peaks as shown in figure 2. The validity of the envelope as to its logarithmic approximation is established by plotting the magnitude of the envelope against time on the semilogarithmic graph paper. A straight-line variation is the necessary criterion. Once this criterion is satisfied, formulas (1) and (2) may be applied, with necessary substitutions, to determine the airplane longitudinal-stability derivatives.

ACCURACY

The accuracy of the data is indicated by the accuracies of the recording instruments as follows:

Angle of attack, α , degrees	± 0.2
Pitching velocity, q , radians per second	± 0.005
Normal acceleration, n ,	± 0.01

RESULTS AND DISCUSSION

Transient Responses

Presented in figure 3 are two representative transient oscillations following a small stabilizer disturbance for a high-subsonic Mach number ($M = 0.82$) and a supersonic Mach number ($M = 1.02$) at altitudes of 32,000 and 52,000 feet, respectively.

The subsonic oscillation is analyzed over the time interval between times 1.0 second and 3.25 seconds. The decay of the pitching-velocity trace over this time interval is shown to be logarithmic by figure 4. It can be seen that once the disturbance ends the elevator is maintained at a reasonably constant value, thus eliminating any appreciable effects of the elevator. The normal-acceleration trace indicates that the airplane was in an approximately level-flight condition.

The supersonic oscillation (fig. 3) is analyzed over the time interval 2.0 to 4.5 seconds. The decay of the pitching-velocity trace as to its logarithmic approximation is shown in figure 4. As in the high-subsonic case, the elevator motion after the initial disturbance ends is small, eliminating any appreciable elevator effects on the oscillation.

Longitudinal-Stability Derivatives

Damping in pitch $C_{mq} + C_{mD\alpha}$.-- The variation of the damping-in-pitch derivative expressed as $C_{mq} + C_{mD\alpha}$ with Mach number is presented in figure 5. Based on the assumptions made, the damping is a function of the damping derivative $C_{mq} + C_{mD\alpha}$ and the lift-curve slope $C_{L\alpha}$. The lift-curve slope as used in the reduction of the data to the damping derivative is obtained from unpublished full-scale flight data and its variation with Mach number is presented in figure 6.

This variation of lift-curve slope was used in preference to the values that could be obtained by plotting C_L against α for each transient response because of a malfunctioning of the angle-of-attack indicator during most of the transient responses used.

Between the Mach numbers 0.72 and 1.12 the damping has significant variations increasing from -0.19 at a Mach number of 0.72 to -0.36 at a Mach number of 0.82, decreasing then to a value of -0.14 at a Mach number of 0.92, and increasing again to -0.402 at a Mach number of 1.08. Minimum damping is indicated between the Mach numbers of 0.91 and 0.95. Above a Mach number of 1.08 the data indicate decreasing damping with increasing Mach number.

Some uncertainty was encountered in the reduction of the data over the Mach number range of 0.91 to 0.95. Presented in figure 7 are time histories of three transient oscillations in this range. Oscillations a and b are at a Mach number of 0.91 and differ only in altitude. Oscillation c begins at a Mach number of 0.95 and ends at a Mach number of 0.92. An attempt has been made to analyze these oscillations for the damping, and the values obtained are presented in figure 8. Two points above and below the Mach number range 0.91 to 0.95 taken from figure 5 are shown to indicate the order of magnitude of the variation.

By examination of the responses in figure 7 it can be seen that the oscillations are not entirely free of elevator movement after the disturbance. This could, and probably does, affect the damping to such an extent as to make the damping derivatives doubtful even though the elevator effectiveness is low. (See reference 3.) However, it is not probable that the elevator movement alone could cause such a large change in damping as indicated in figure 8, but it does provide an argument against the use of a simplified transient analysis in determining the damping derivatives from transient responses with appreciable elevator movement.

Static-stability derivative $C_{m\alpha}$. - It has been shown that the static stability of an airplane is a function of the natural frequency and the rate of decay of the free oscillation. These data obtained from the transient oscillations are reduced to the variation of airplane static stability with Mach number which is presented in figure 9. Between Mach numbers 0.90 and 0.95 there is a marked increase in $C_{m\alpha}$ that is a maximum at a Mach number of 0.92. At Mach numbers above 0.95 the data indicate gradual decreasing stability to a value of -0.034 at a Mach number of 1.12.

It should be noted that several points are calculated neglecting the rate of decay of the transient oscillation. Since $C_{m\alpha}$ is for the most part a function of the frequency, these points between the Mach numbers 0.90 and 0.95 are presented calculated from the frequency only rather than being omitted because of the uncertainty of the damping. Between Mach number 0.91 and Mach number 1.02 the data indicate an effect of lift coefficient on the airplane static stability - lower lift coefficients showing lower stability.

Comparison of Flight Data and Model Data

Damping in pitch $C_{mq} + C_{mD\alpha}$. - A comparison of the full-scale experimental data estimated from wind-tunnel tests at high-subsonic speeds (reference 4) and the data obtained from rocket-model tests at supersonic speeds (reference 2) is presented in figure 10. It should be noted that the rocket model is not of the X-1 airplane but is of a

somewhat similar configuration and is compared with the X-1 scaled to equivalent l_t/c in figure 11.

Good agreement exists between the flight data and model data over the entire Mach number range from 0.72 to 1.12. It can be seen that the estimated variation of damping between the Mach numbers 0.90 and 0.92 for a lift coefficient of approximately 0.3 is not indicative of any large changes in damping as characterized by the flight data at a lift coefficient of 0.6. It then appears that part of the uncertainty of the experimental damping may be attributed to lift-coefficient effects over the Mach number interval from 0.90 to 0.92 and near the maximum stability of the airplane.

Further investigation is to be conducted to determine more completely the damping characteristics of the Bell X-1 airplane.

Static-stability derivative $C_{m\alpha}$. - Presented in figure 12 is a comparison of the full-scale experimental data to the stability estimated from wind-tunnel data (reference 4) and the free-fall data (reference 5) at high-subsonic speeds. These reference data are corrected to a center-of-gravity position of 23.2 percent mean aerodynamic chord and pertain to the airplane with the 10-percent-thick wing. Good agreement exists between the full-scale data and the tunnel data to a Mach number of approximately 0.875 after which the airplane stability increases more rapidly than is indicated by the tunnel data. The discrepancy between the full-scale data and the free-fall data may in part be due to the model having a wing thickness of 10 percent as compared to a wing thickness of 8 percent for the full-scale airplane. Above a Mach number of 0.91 the flight data show good agreement with the free-fall data for a lift coefficient of about 0.3.

CONCLUDING REMARKS

From the analysis of the transient oscillations of the Bell X-1 airplane it was concluded that:

1. The damping characteristics have significant variations over the Mach number interval from 0.72 to 1.12. The over-all variation is between the values -0.19 to -0.402 with maximum damping of -0.36 and -0.402 at Mach numbers of 0.82 and 1.08, respectively. Minimum damping is indicated between the Mach numbers of 0.91 and 0.95.
2. The damping determined from full-scale flight data is in good agreement with model data.

3. Some uncertainty exists as to the changes in damping between Mach numbers of 0.91 and 0.95. Damping-derivative values change from -1.27 to 0.14 for a Mach number change of 0.91 to 0.95 at a lift coefficient of 0.6. Comparison of flight data and model data indicates a possible lift-coefficient effect.

4. The airplane static longitudinal stability increases to a maximum at a Mach number of 0.92 followed by a decrease with further increase in Mach number.

5. The stability determined from flight oscillations is in good agreement with model data.

Langley Aeronautical Laboratory
National Advisory Committee for Aeronautics
Langley Air Force Base, Va.

REFERENCES

1. Williams, Walter C., Forsyth, Charles M., and Brown, Beverly P.: General Handling-Qualities Results Obtained during Acceptance Flight Tests of the Bell XS-1 Airplane. NACA RM L8A09, 1948.
2. Gillis, Clarence L., Peck, Robert F., and Vitale, A. James: Preliminary Results from a Free-Flight Investigation at Transonic and Supersonic Speeds of the Longitudinal Stability and Control Characteristics of an Airplane Configuration with a Thin Straight Wing of Aspect Ratio 3. NACA RM L9K25a, 1950.
3. Drake, Hubert M., Carden, John R.: Elevator-Stabilizer Effectiveness and Trim of the X-1 Airplane to a Mach Number of 1.06. NACA RM L50G20, 1950.
4. Mattson, Axel T., Loving, Donald L.: Force, Static Longitudinal Stability, and Control Characteristics of a $\frac{1}{16}$ -Scale Model of the Bell XS-1 Transonic Research Airplane at High Mach Numbers. NACA RM L8A12, 1948.
5. Matthews, James T., Jr., and Mathews, Charles W.: Determination by the Free-Fall Method of the Longitudinal Stability and Control Characteristics of a $\frac{1}{4}$ -Scale Model of the Bell XS-1 Airplane at Transonic Speeds. NACA RM L8G29a, 1948.

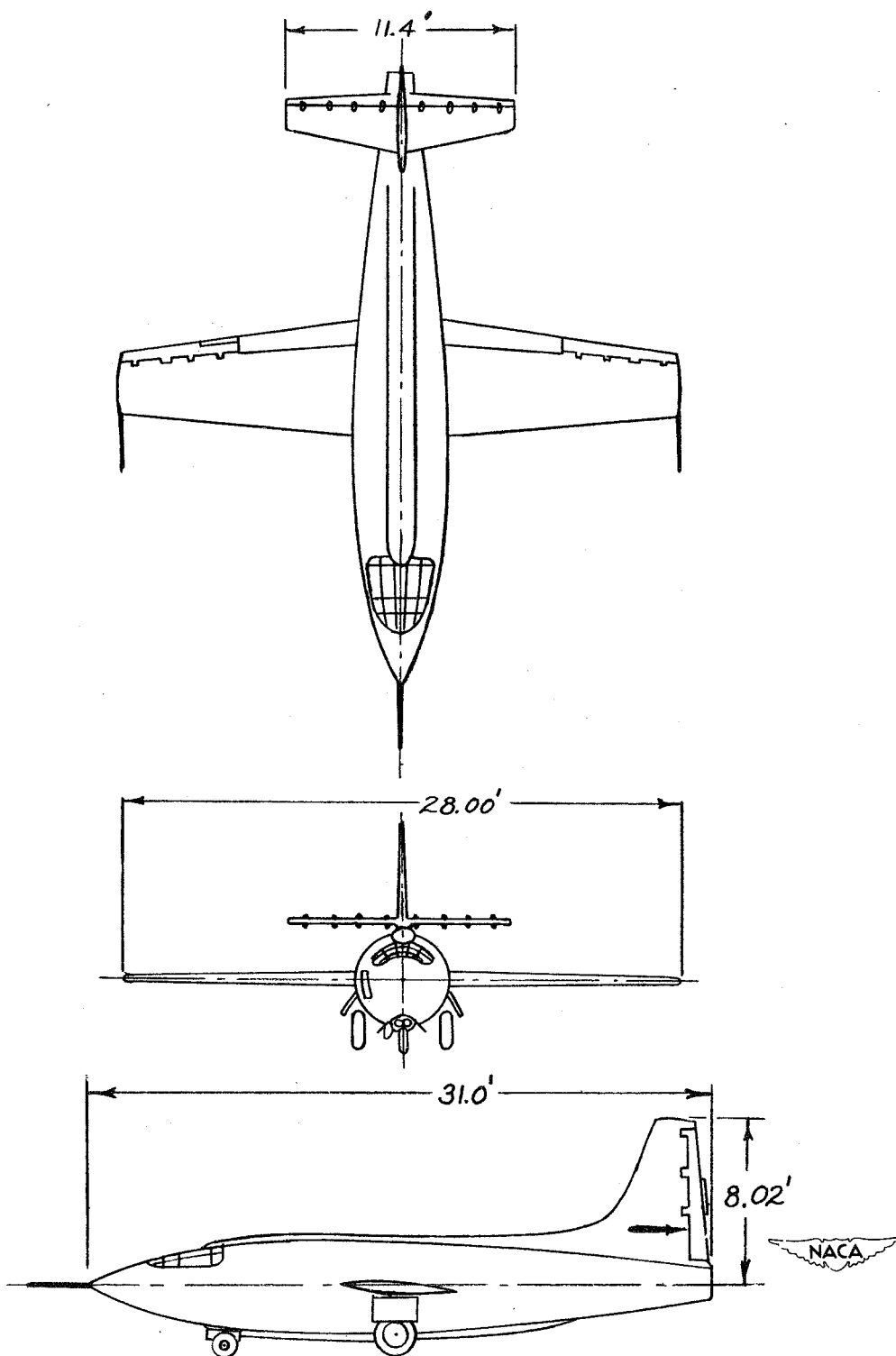

Figure 1.- Three-view drawing of the Bell X-1 airplane.

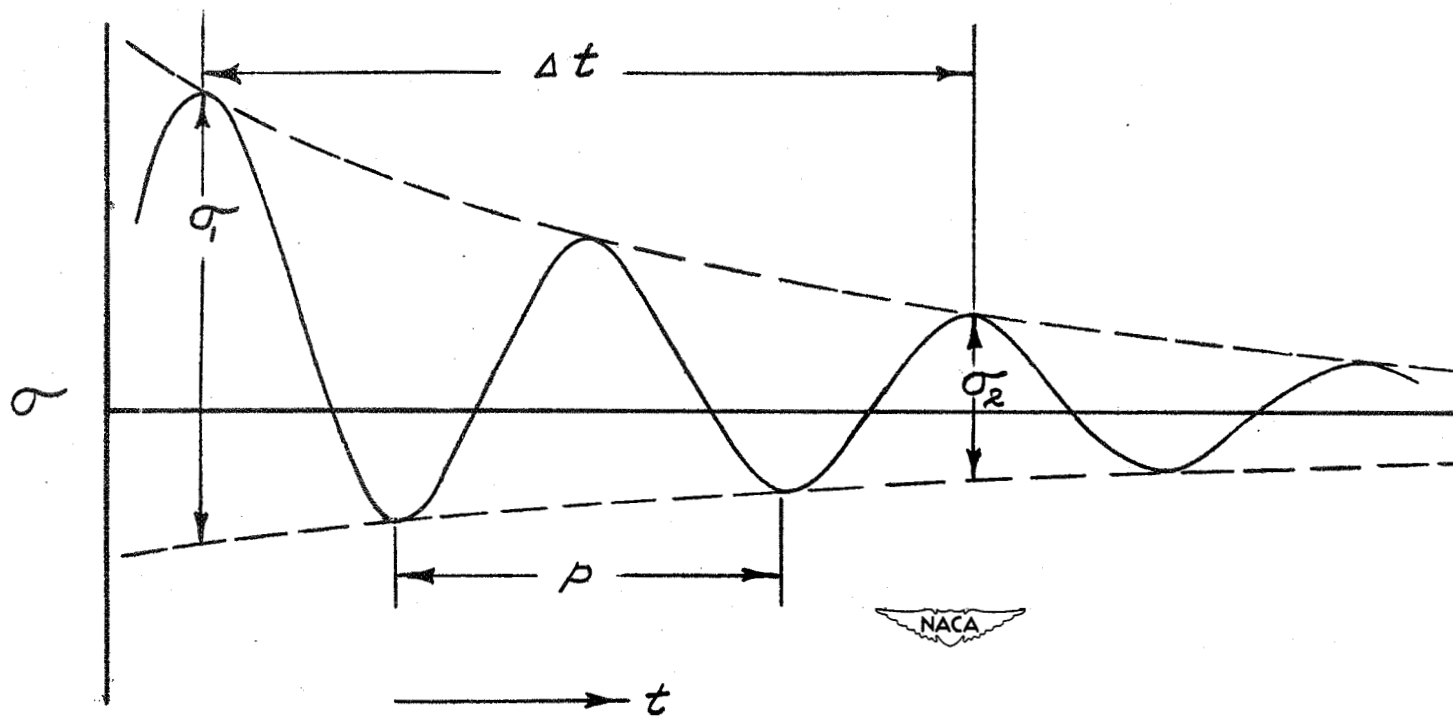
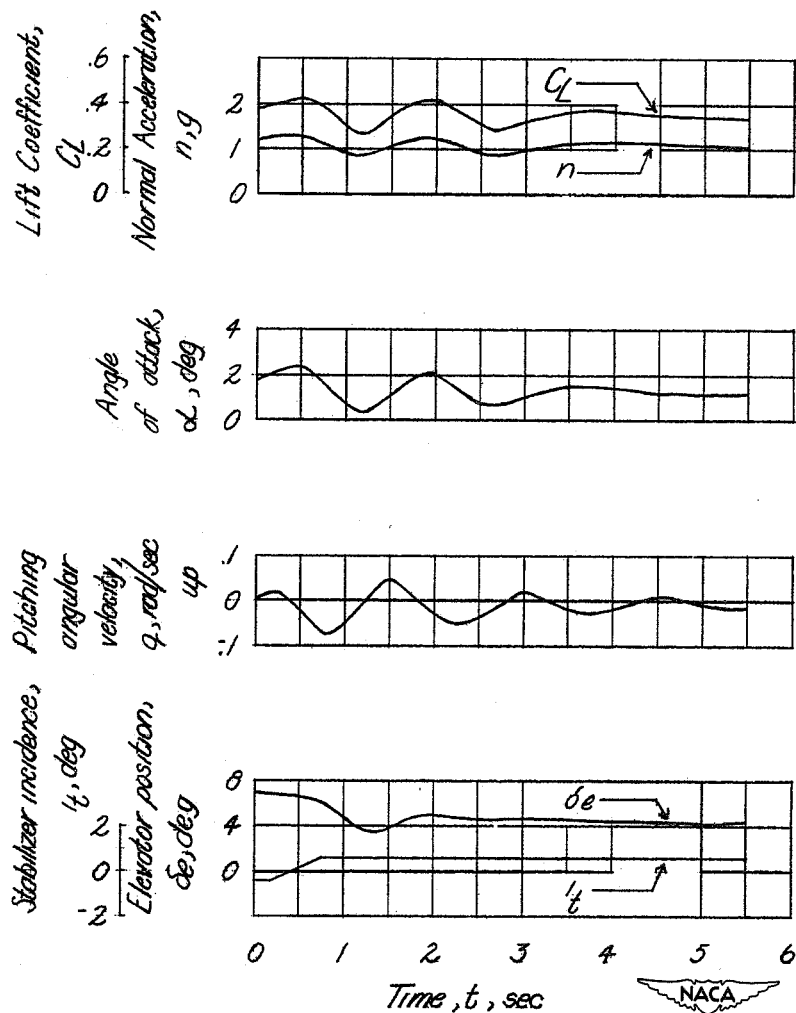
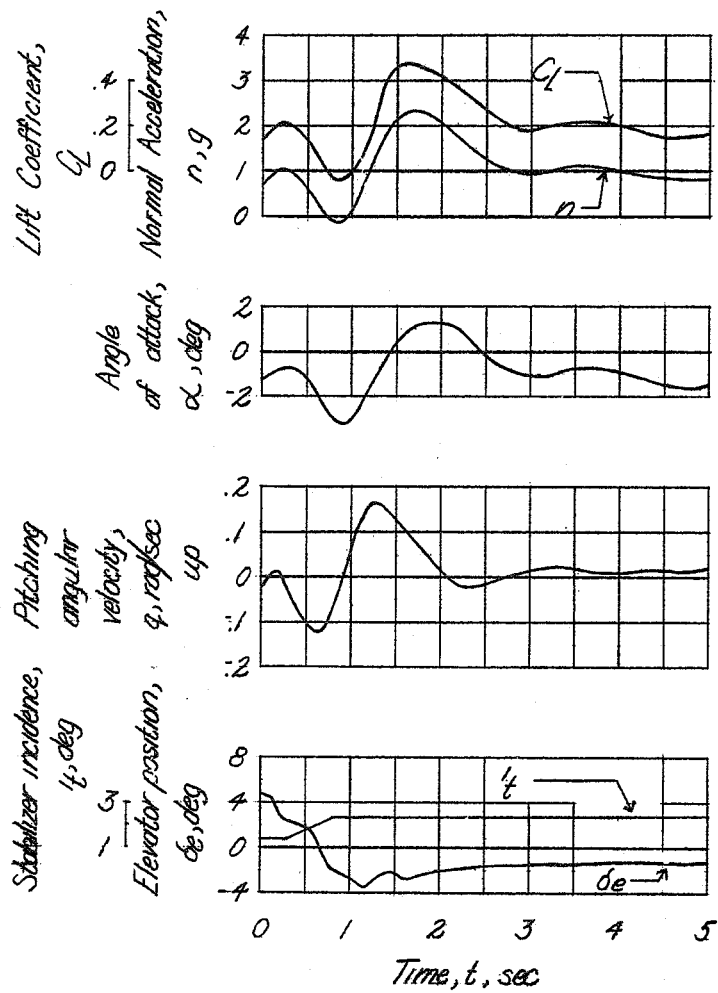

Figure 2.- Graphical approach to analysis of transient responses.



(a) Subsonic; $M \approx 0.825$; $H = 32,000$. (b) Supersonic; $M \approx 1.025$; $H = 52,000$.

Figure 3.- Time histories of typical transient oscillations.

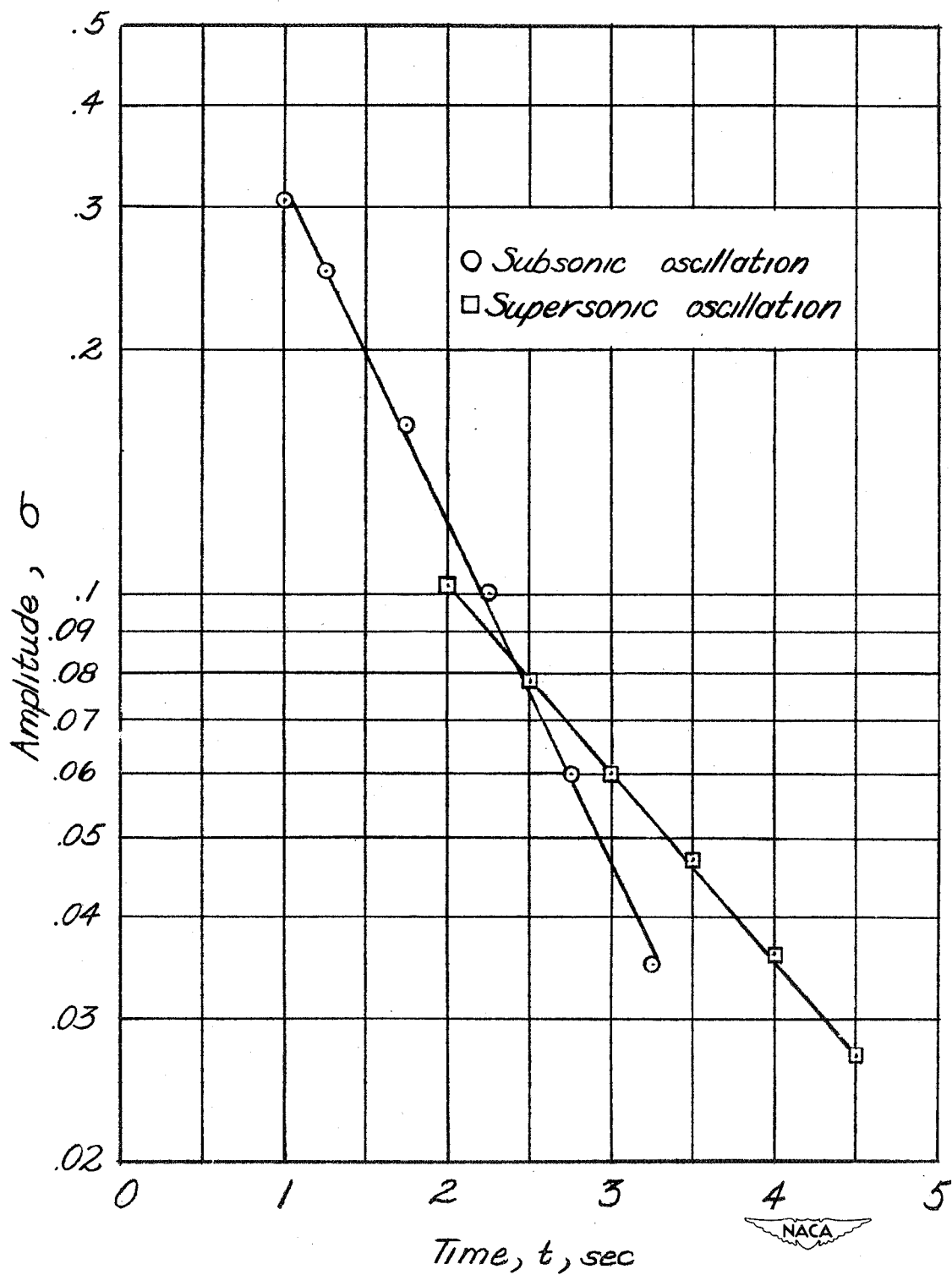

Figure 4.- Verification of the constructed envelope of exponential order.

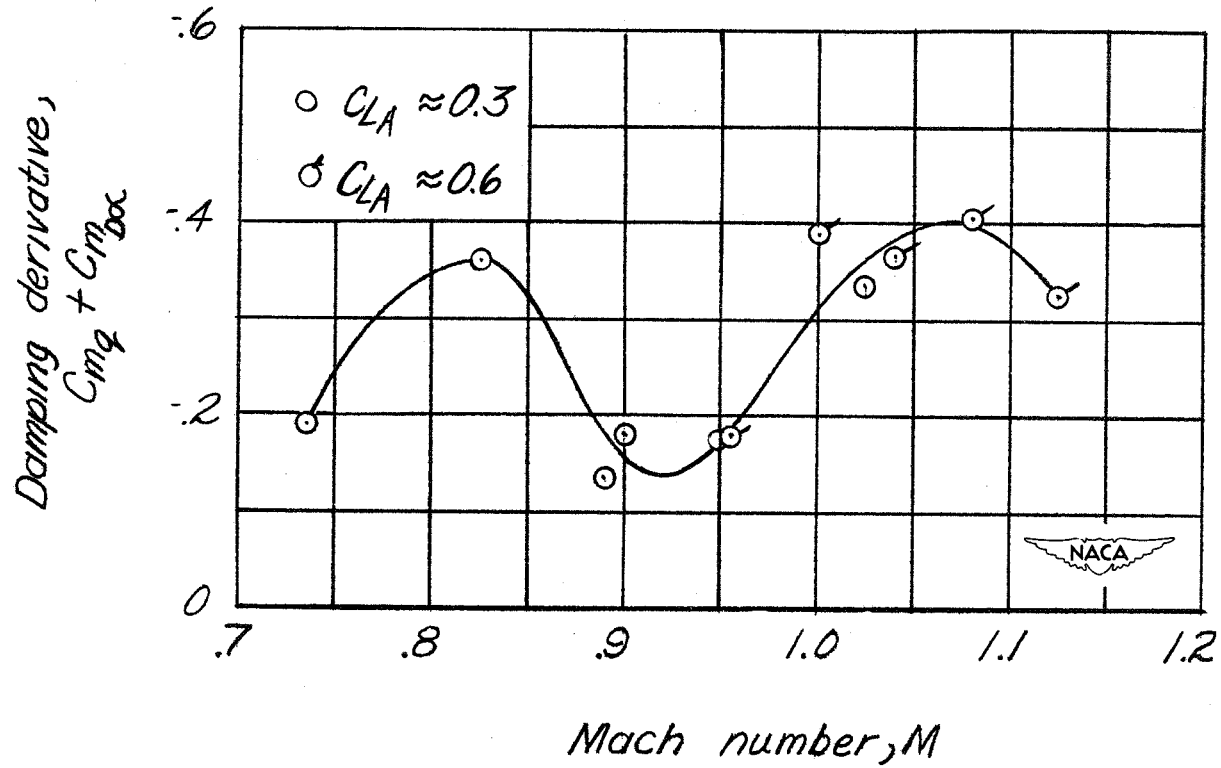

Figure 5.- Variation of damping with Mach number.

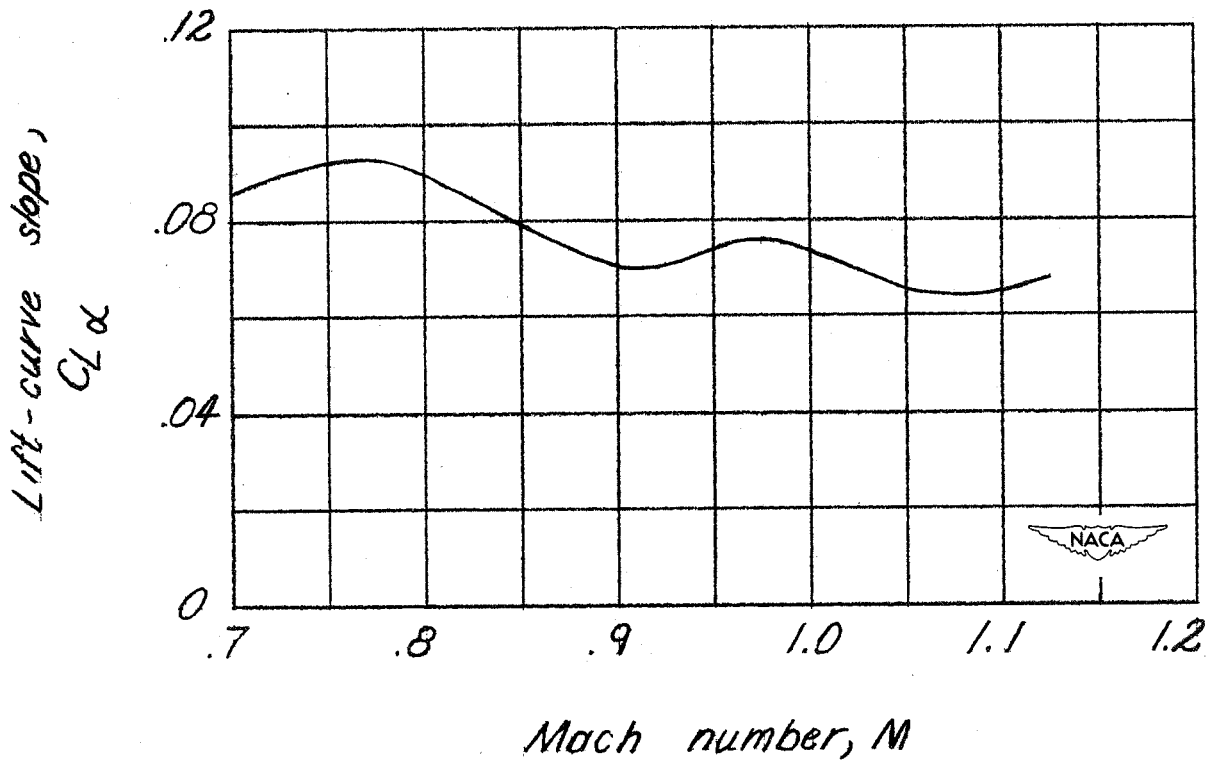
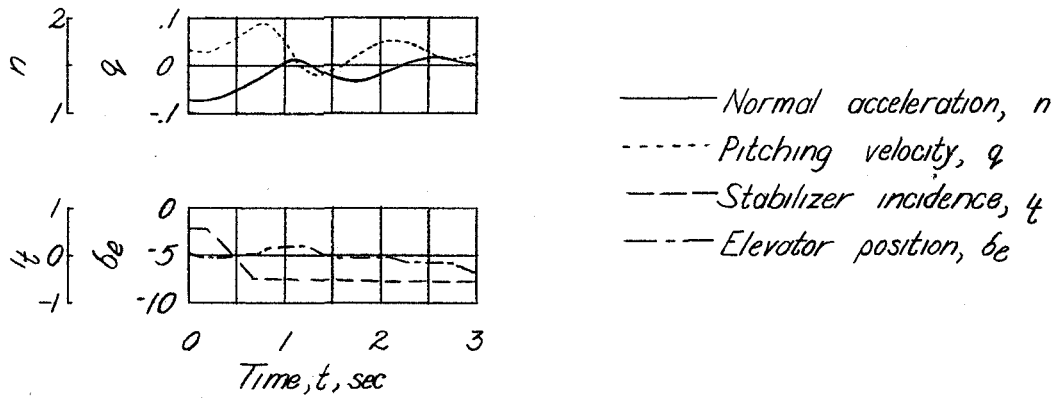
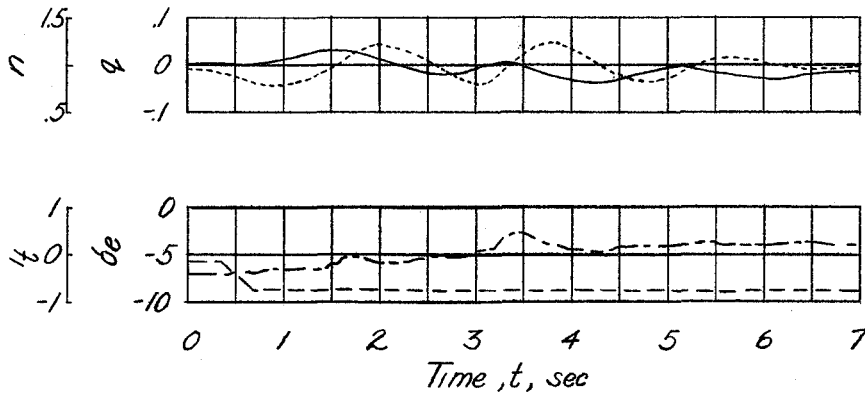

Figure 6.- Variation of lift-curve slope with Mach number.



(a) $M \approx 0.91$; $H = 45,000$.



(b) $M \approx 0.91$; $H = 55,000$.

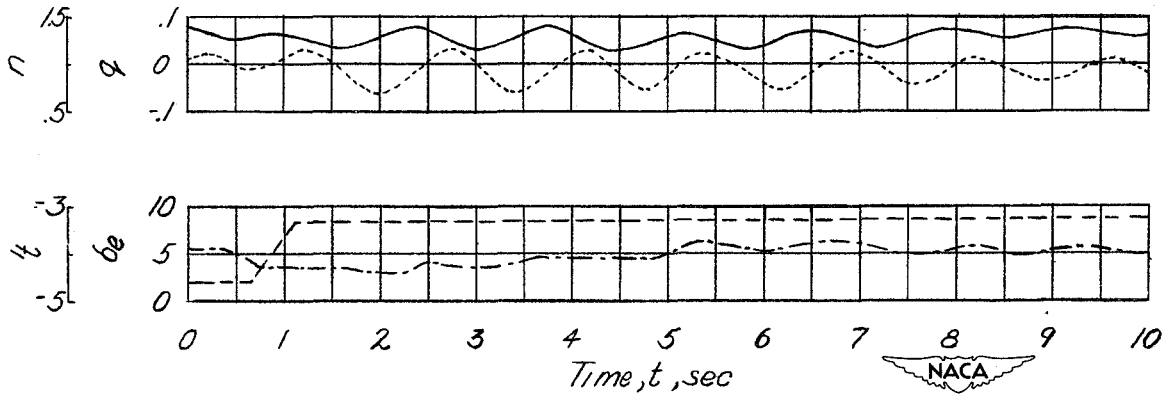

(c) $M \approx 0.95$ to 0.92 ; $H = 53,000$.

Figure 7.- Time histories of transient oscillations between Mach number 0.91 and 0.95 and lift coefficient of 0.6.

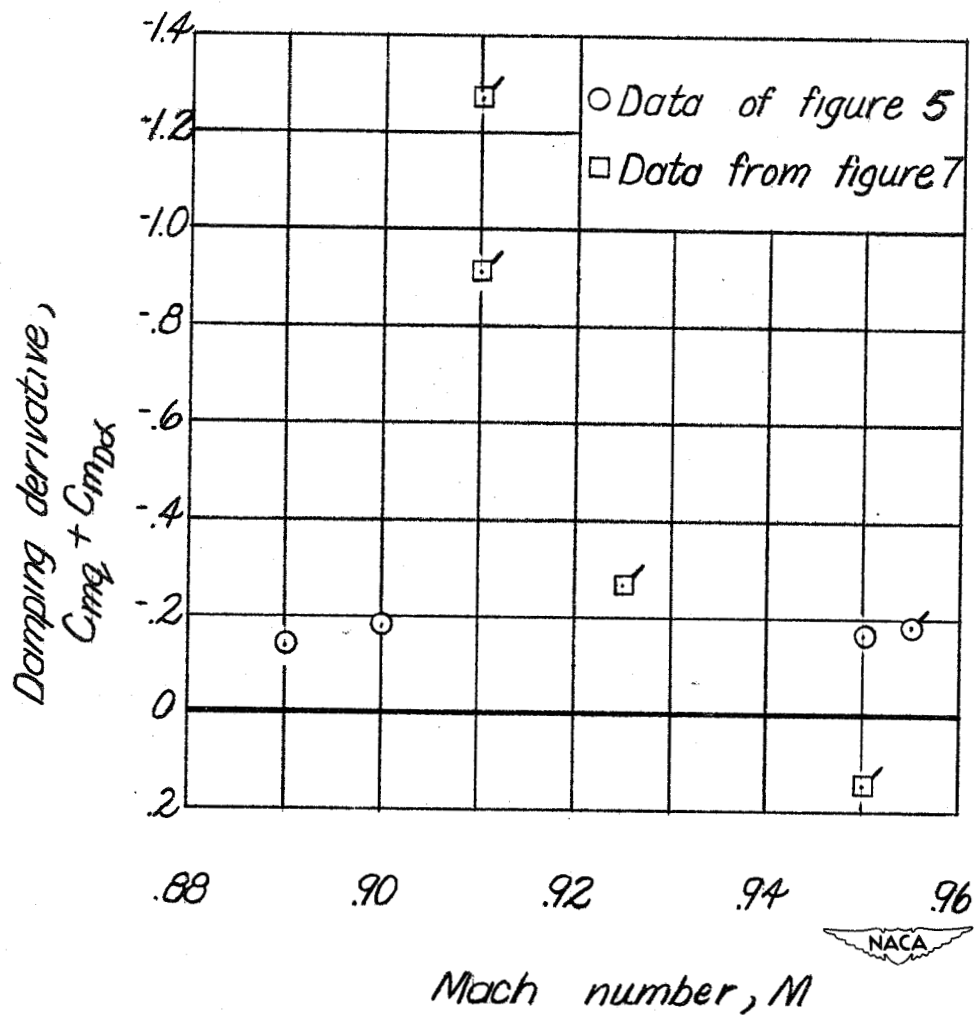

Figure 8.- Variation of damping derivative over range of uncertain damping.

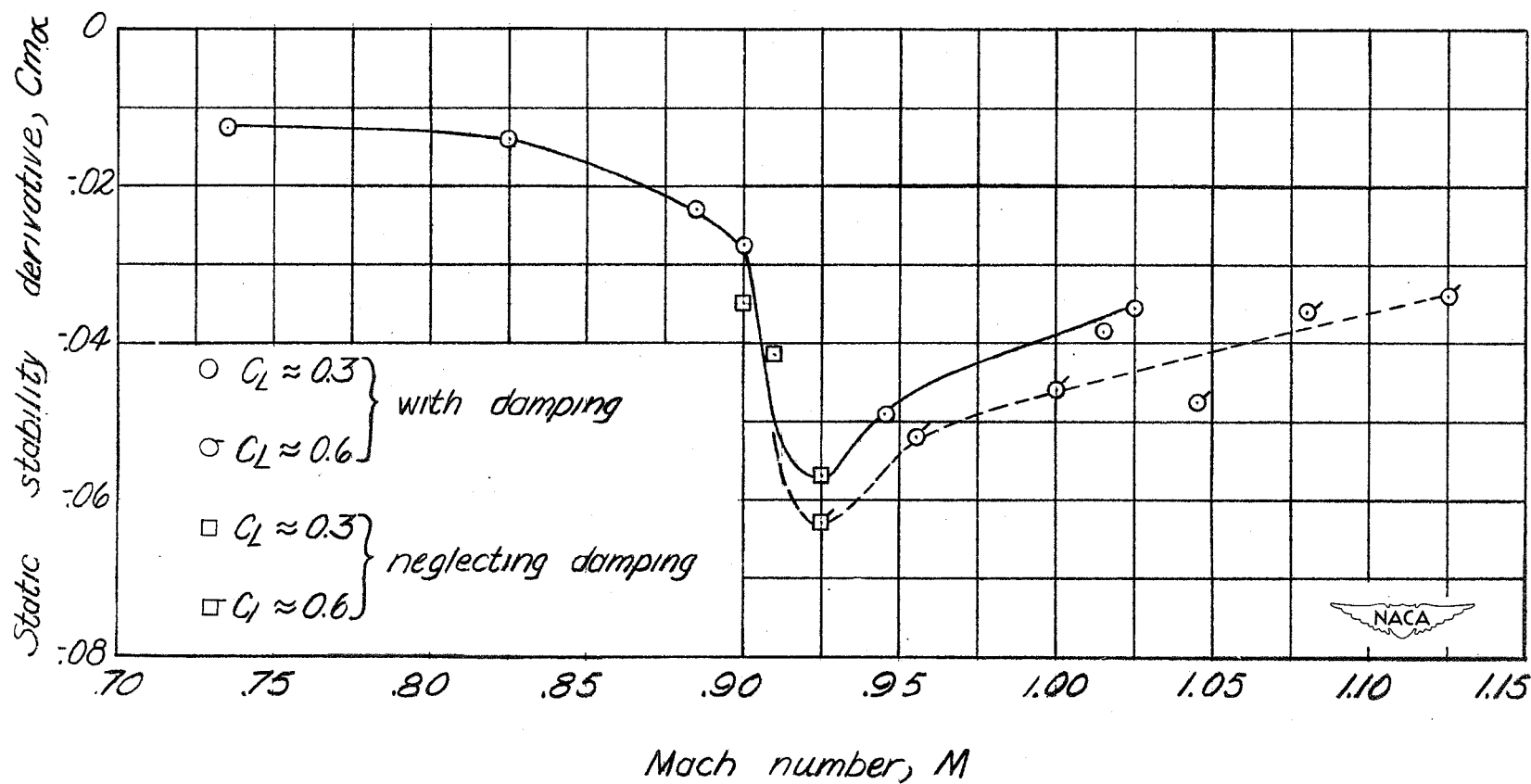

Figure 9.- Variation of static stability with Mach number as determined from transient oscillations.

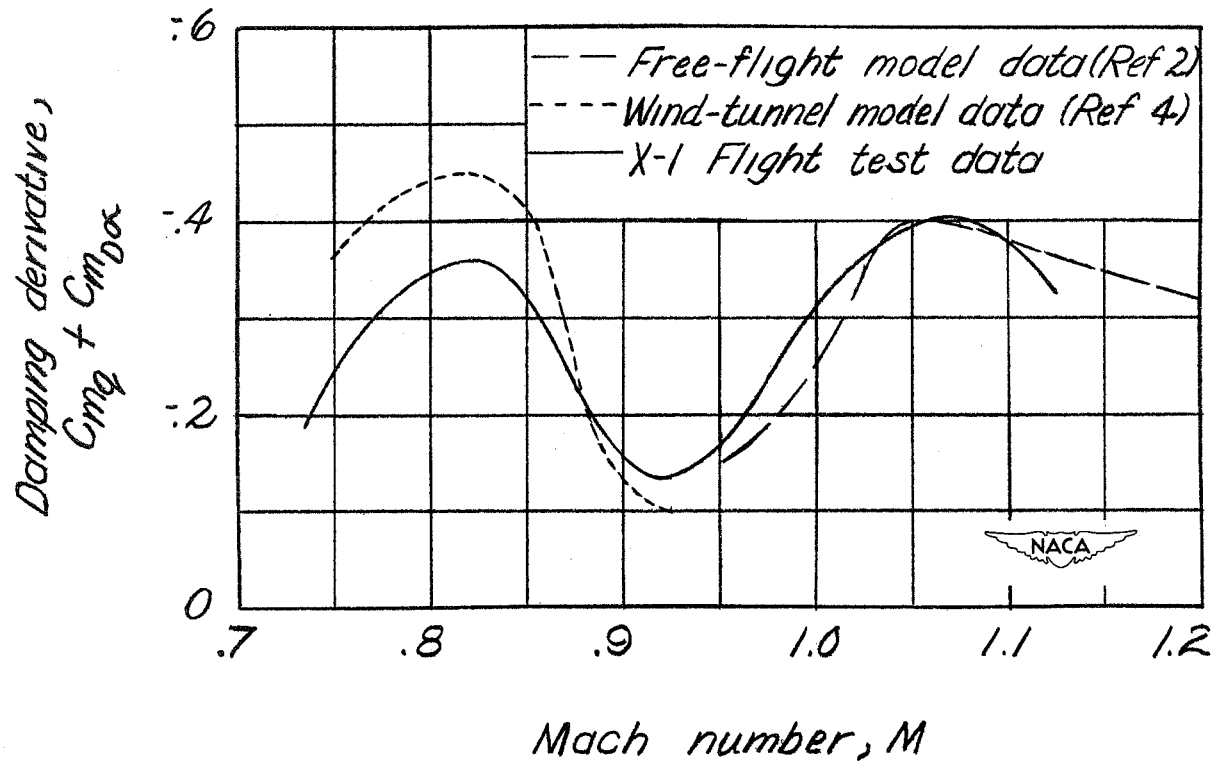

Figure 10.- Comparison of full-scale data with model data.

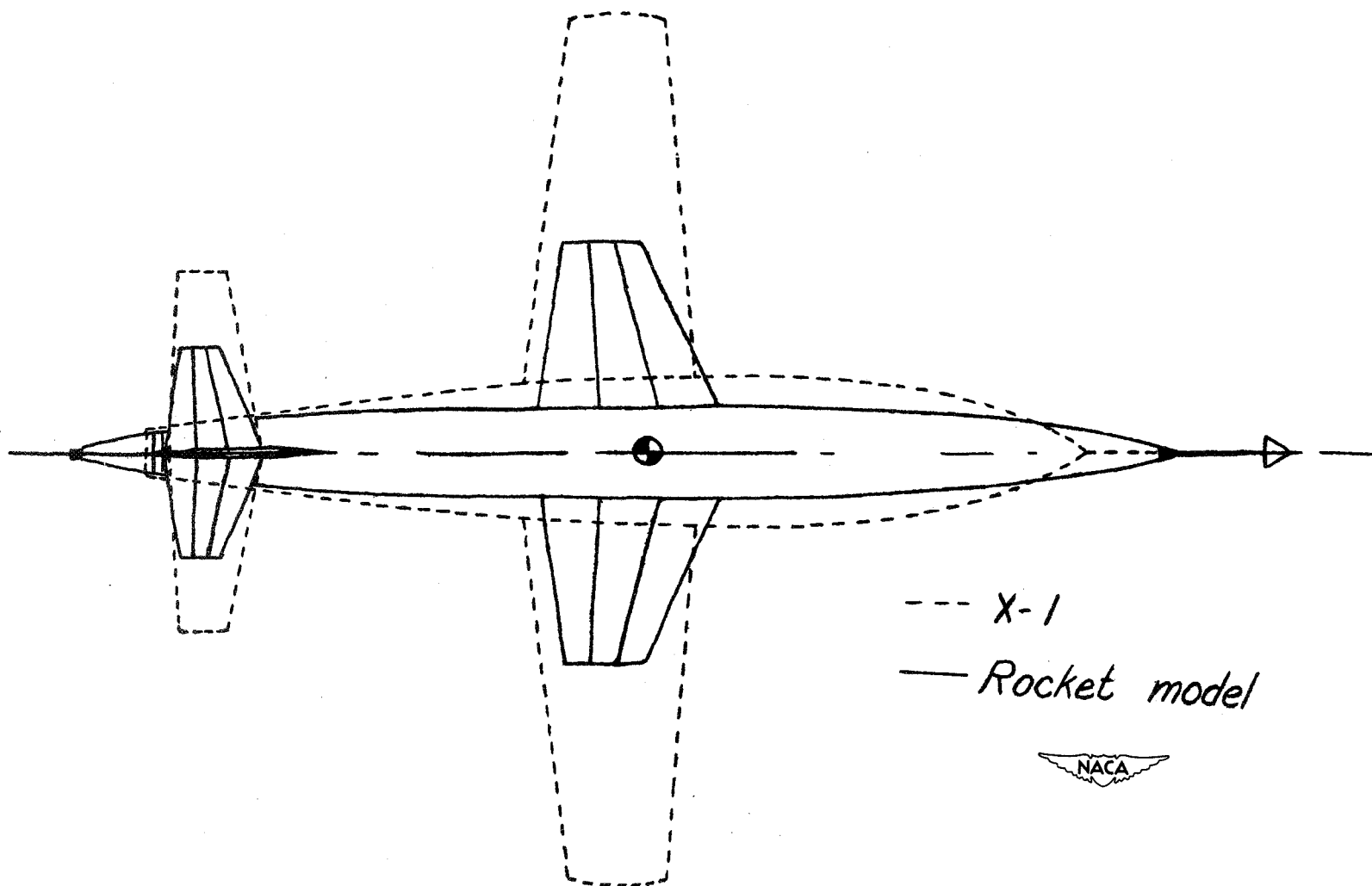

Figure 11.- Comparison of Bell X-1 airplane and missile for equivalent l_t/c .

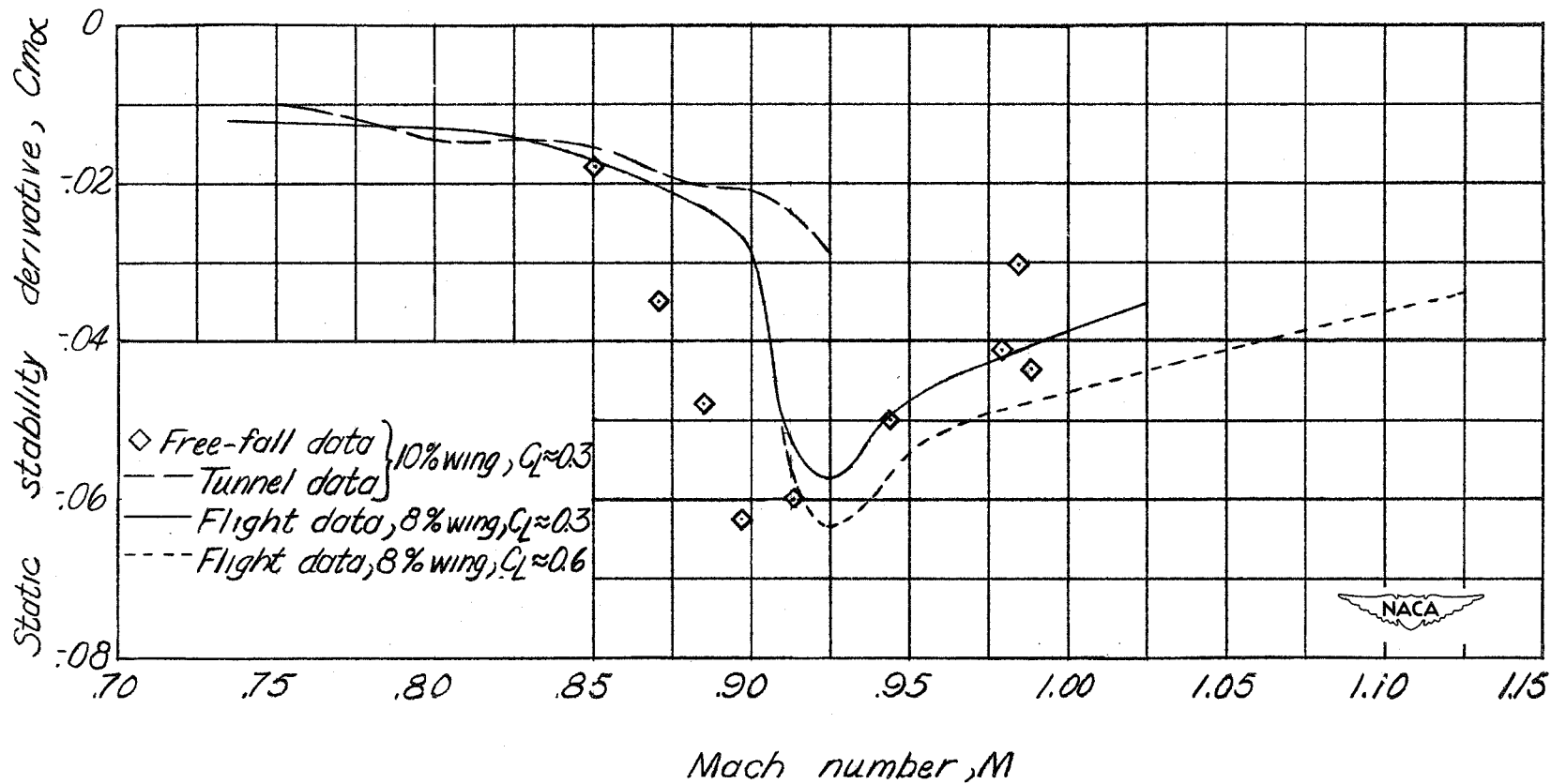

Figure 12.- Comparison of full-scale data with model data. Center of gravity at 23.0 percent mean aerodynamic chord.