

RM E50L12

NACA RM E50L12

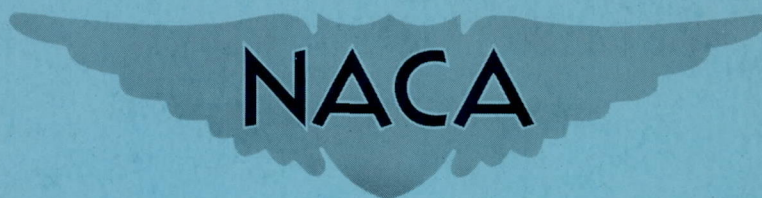

RESEARCH MEMORANDUM

AN ELECTROMAGNETIC FLOWMETER FOR ROCKET RESEARCH

By Leonard Jaffe, Bert A. Coss, and Donald R. Daykin

Lewis Flight Propulsion Laboratory
Cleveland, Ohio

NATIONAL ADVISORY COMMITTEE
FOR AERONAUTICS

WASHINGTON
March 6, 1951

100-100000-100000

NATIONAL ADVISORY COMMITTEE FOR AERONAUTICS

RESEARCH MEMORANDUM

AN ELECTROMAGNETIC FLOWMETER FOR ROCKET RESEARCH

By Leonard Jaffe, Bert A. Coss, and Donald R. Daykin

SUMMARY

A method of measuring instantaneous flow rates of liquid propellants for rocket research is presented. The instrument investigated utilizes the principle of electromagnetic induction.

An electromagnetic flowmeter was built, investigated, and satisfactorily placed in service to measure the rate of flow of an oxidant into a rocket.

The advantages of this electromagnetic flowmeter consist of (1) its linear calibration curve, which is independent of density and insensitive to the velocity profile; (2) an absence of appreciable lag, which makes it suitable for measurements of instantaneous velocity in rapidly pulsing systems; (3) the absence of any movable parts or restrictions in the flowmeter pipe; and (4) the bidirectional response of the instrument.

INTRODUCTION

The investigation of the pulsation phenomenon in rocket research has made necessary the measurement of instantaneous rates of flow of liquid propellants. None of the available equipment for measuring the rate of flow could meet the requirement of short response time necessary for the measurement of transients.

A short response time is not the only requirement that must be met by a practical instrument. Propellants and oxidants are generally hazardous. In most cases, these fluids are unstable, corrosive, and toxic, which means that the instrument must be capable of remote operation and the materials used in its construction must have both strength and resistance to corrosion.

On the basis of these requirements, a system that utilizes the electromotive force induced in a fluid moving through a magnetic field (reference 1) was investigated. In order to investigate this electromagnetic system of measuring flow, an experimental meter was built at the NACA Lewis laboratory and applied to rocket research.

PRINCIPLE OF INSTRUMENT

The principle of the electromagnetic flowmeter is similar to that of a dynamo or generator. The arrangement of the basic components of the meter is shown in figure 1. The magnet produces a magnetic field between the two magnet poles. As the fluid traverses the magnetic field, an electromotive force is induced in the fluid perpendicular to both the direction of the magnetic field and the direction of flow. This electromotive force is picked up by the electrodes; its magnitude is given by Faraday's law,

$$E = B l v \times 10^{-8}$$

where

E induced voltage

B magnetic flux density, (lines/sq in.)

l path over which induced voltage is integrated (in this case, l is equal to diameter of pipe in inches).

v velocity of fluid with respect to magnetic field, (in./sec)

Faraday's expression for the induced voltage exhibits no dependence on such variables as charge, conductivity, and specific inductive capacity. Thus, an electric field is assumed to exist whenever a medium is passed through a magnetic field. It may be shown, however, that the terminal voltage arising from this induced voltage is attenuated in a manner dependent on the nature of the medium. Mittlemann and Cushing in an unpublished work express this dependence in the form of an attenuation factor α :

$$\alpha = \frac{1}{\sqrt{1 + \left(\frac{2\pi\tau}{T}\right)^2}}$$

where

$\tau = \epsilon\epsilon_0/\sigma$ relaxation time of medium, (sec)

$T = 2\pi/\omega$ period of alternation of magnetic induction, (sec)

ϵ dielectric constant

- ϵ_0 permittivity of free space, (farads/m)
 σ electrical conductivity, (mhos/m)
 ω angular frequency, (sec^{-1})

Examination of the attenuation constant shows that the relaxation time must be short with respect to the period of alternation. For negligible attenuation of the signal in a given meter, with an alternating field of 400 cycles per second, the relaxation time must be less than 10^{-4} second.

Sample relaxation times are given in the following table:

Substance	Relaxation time, sec
Sulfuric acid, pure	7.0×10^{-10}
Methyl alcohol	4.0×10^{-7}
Water, pure	3.6×10^{-6}
Acetone	1.0×10^{-4}
Petroleum	4.0×10^3

There is reason to believe that liquids such as the petroleum oils can be sufficiently contaminated to give them acceptable relaxation times for electromagnetic flowmeter operation.

DESCRIPTION OF METER

A cross section of the experimental flowmeter and a photograph of the meter are shown in figures 2 and 3, respectively. The material of which the flow passage (B) is made must be an electrical insulator, nonmagnetic, chemically inert in the presence of rocket propellants, and strong enough structurally to withstand the high pressures encountered in this type of application. The tetrafluoroethylene polymer Teflon meets these requirements. Stainless-steel flanges (C) connect the flow-metering section and the pipe system into which the meter is inserted. Laminations of high-quality audio transformer steel are used for the magnetic structure (D) on which two coils are mounted. These coils, when connected in parallel and resonated with proper capacitance, produce a field in the gap between the poles of approximately 17,000 lines per square inch with an applied voltage of 300 volts at a frequency of 400 cycles per second.

Stainless-steel electrodes (A) project into the flow passage to tap off the induced electromotive force. Connections are made to these electrodes by conductors enclosed in a pair of steel conduits for each electrode, as shown in figure 3. Each pair of conduits forms a symmetrical electrical system with respect to the magnetic structure, thus minimizing any "noise" voltage that may be transformed from the magnet coils to the pickup leads. Because perfect symmetry cannot be achieved, any "noise" that is left is eliminated by an equal and opposite voltage derived from the 400-cycle-per-second power source. This procedure follows an impedance transformation through a push-pull cathode-follower circuit, which has a very high input impedance imposing a negligible load on the flow generator.

A block diagram of the electrical circuit is shown in figure 4. After amplification, the signal is applied to an oscilloscope and the waveform is recorded on film. The output waveform as recorded on film appears as a modulated carrier. The carrier frequency is determined by the frequency of the current used to energize the magnet and the modulation or amplitude of this carrier is proportional to the magnitude of flow.

In order to calibrate the flowmeter, a quantity of fluid is passed through the meter at a fixed rate and caught in a discharge weigh tank. The oscilloscope again can be set to give any desired calibration factor.

A response curve was plotted for flows from 0 to 2.5 pounds per second and the result was the linear curve shown in figure 5. Conditions of flow included in this plot vary from laminar to turbulent; the Reynolds number varies from 180 to 4500 on the lowest range of figure 5.

A test was made to determine the effect of a right-angle bend in the pipe at the entrance to the flow section. With the bend 10 diameters from the test section, no effects were recorded.

APPLICATION

In order to determine finally the adaptability of the electromagnetic flowmeter to rocket research, the meter was installed in the oxidant line to a rocket engine under test. Figure 6 shows a record of the flow of oxidant, nitric acid, into a pulsing rocket engine. At the top of the film strip appear timing markers that occur every 1/60 second and at the bottom the timing markers occur every 1/400 second.

As the rocket engine is started (point A), the flow begins to build up. At point B ignition takes place and the pressure in the combustion chamber abruptly rises, causing the flow to decrease rapidly. A study of the phase of the carrier wave and the 400-cycle-per-second timing marks reveals a phase reversal at point C. Previous to point B, the lower peak of the wave form occurs to the right of the lower timing marks and between points C and D the lower peak occurs to the left of the lower timing marks, which indicates the flow has actually reversed. Thus the phase of the carrier indicates direction of flow and the electromagnetic flowmeter is a bidirectional instrument.

The type of record now being obtained by combining the oxidant flow record with an indication of rocket-chamber pressure is shown in figure 7. The first strip is a record of a pulsing rocket engine and the second strip is a record of a smooth run on the same rocket engine. The lower trace in each case is the chamber pressure and the upper trace is the record of flow as indicated by the electromagnetic flowmeter. The phase relation between oxidant flow and chamber pressure can be determined from these films.

CONCLUDING REMARKS

The electromagnetic flowmeter has been successfully used in rocket research. Its instantaneous response, insensitivity to inlet conditions, and adaptability to rugged construction make this flowmeter a desirable instrument. The possibility of adding contaminants to fluids with relaxation times longer than 10^{-4} second suggests the universal adoption of the electromagnetic flowmeter in rocket research.

Future applications of the electromagnetic flowmeter to rocket research might include the measurement of instantaneous fuel-oxidant ratios and the investigation of high-altitude ignition problems. Because the output of the meter is electrical, it may be utilized in a servo-mechanism to control propellant flows with respect to flight variables.

Lewis Flight Propulsion Laboratory,
National Advisory Committee for Aeronautics,
Cleveland, Ohio,

REFERENCE

1. Kolin, Alexander: An Alternating Field Induction Flowmeter of High Sensitivity. Rev. Sci. Instr., vol. 16, no. 5, May 1945, pp. 109-116.

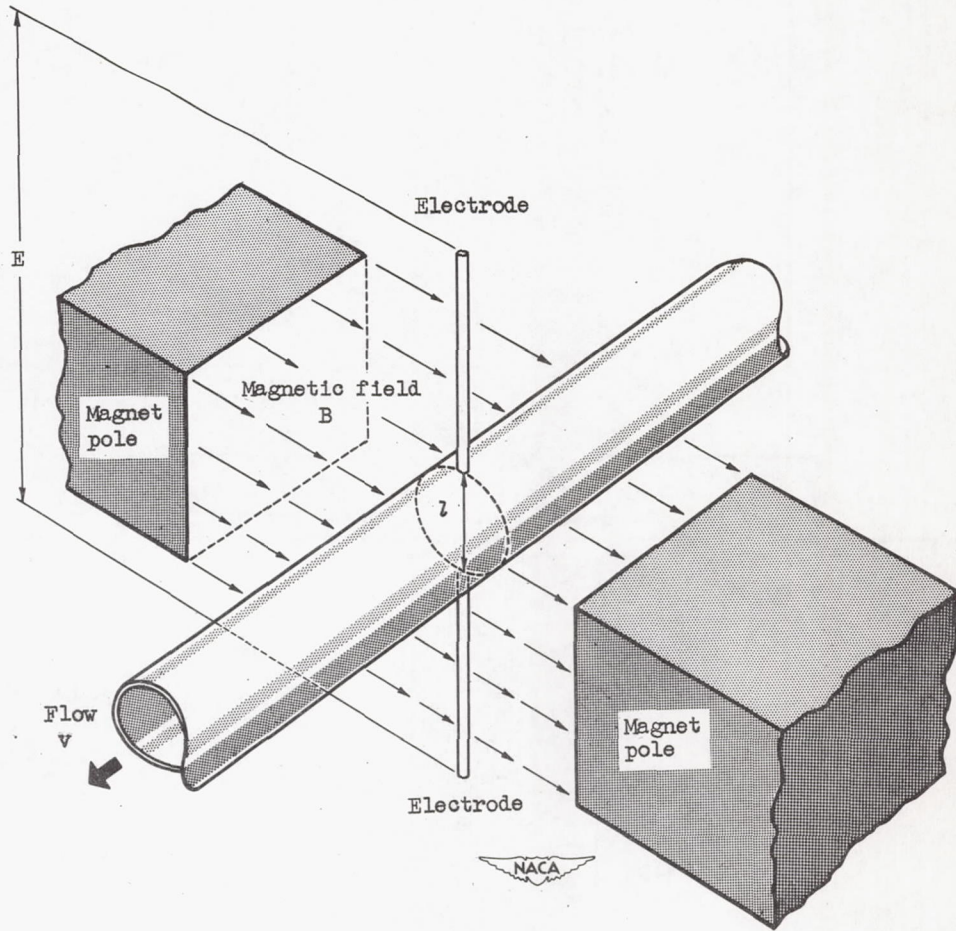

Figure 1. - Basic components of electromagnetic flowmeter.

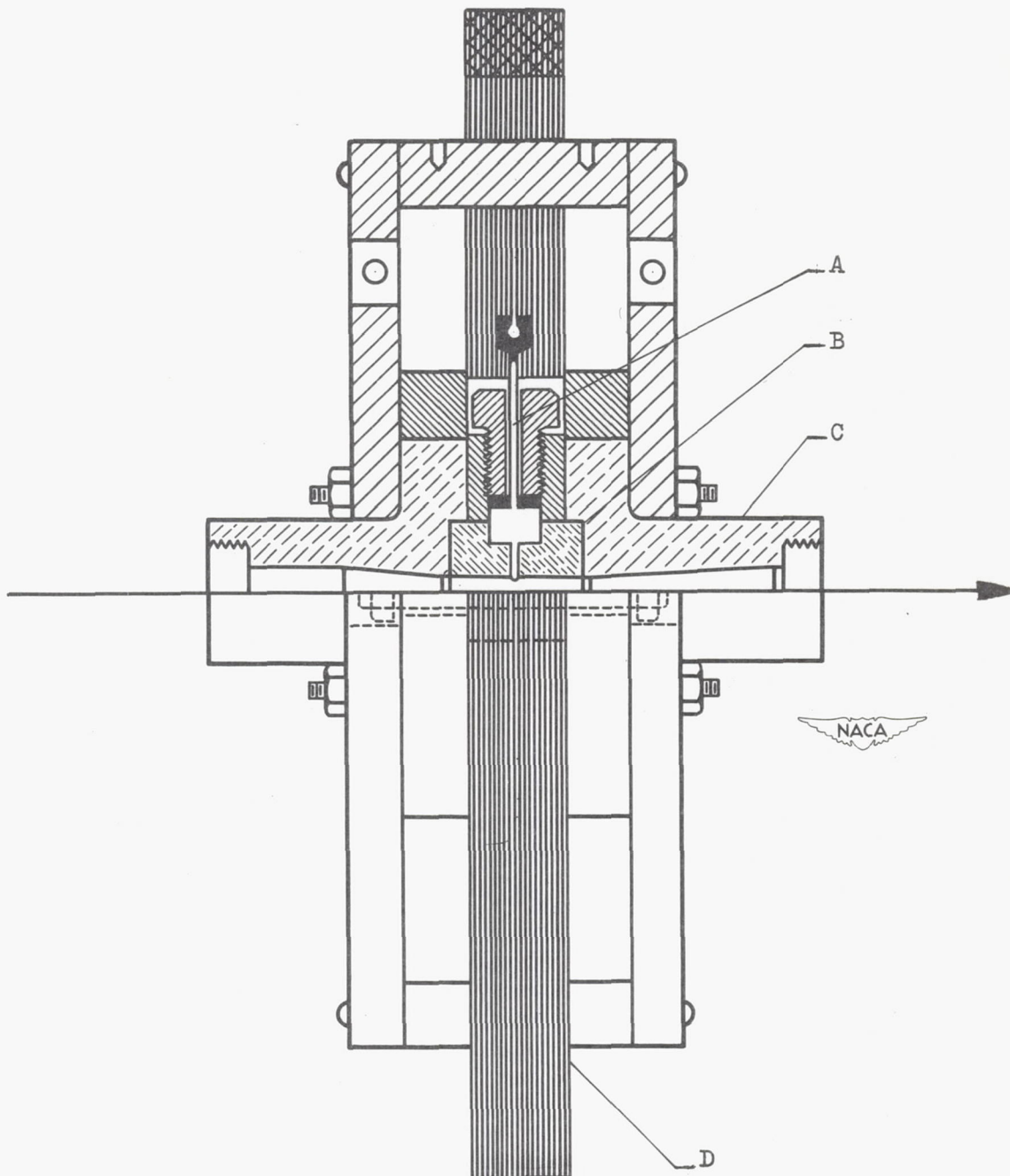

Figure 2. - Assembly of experimental electromagnetic flowmeter.

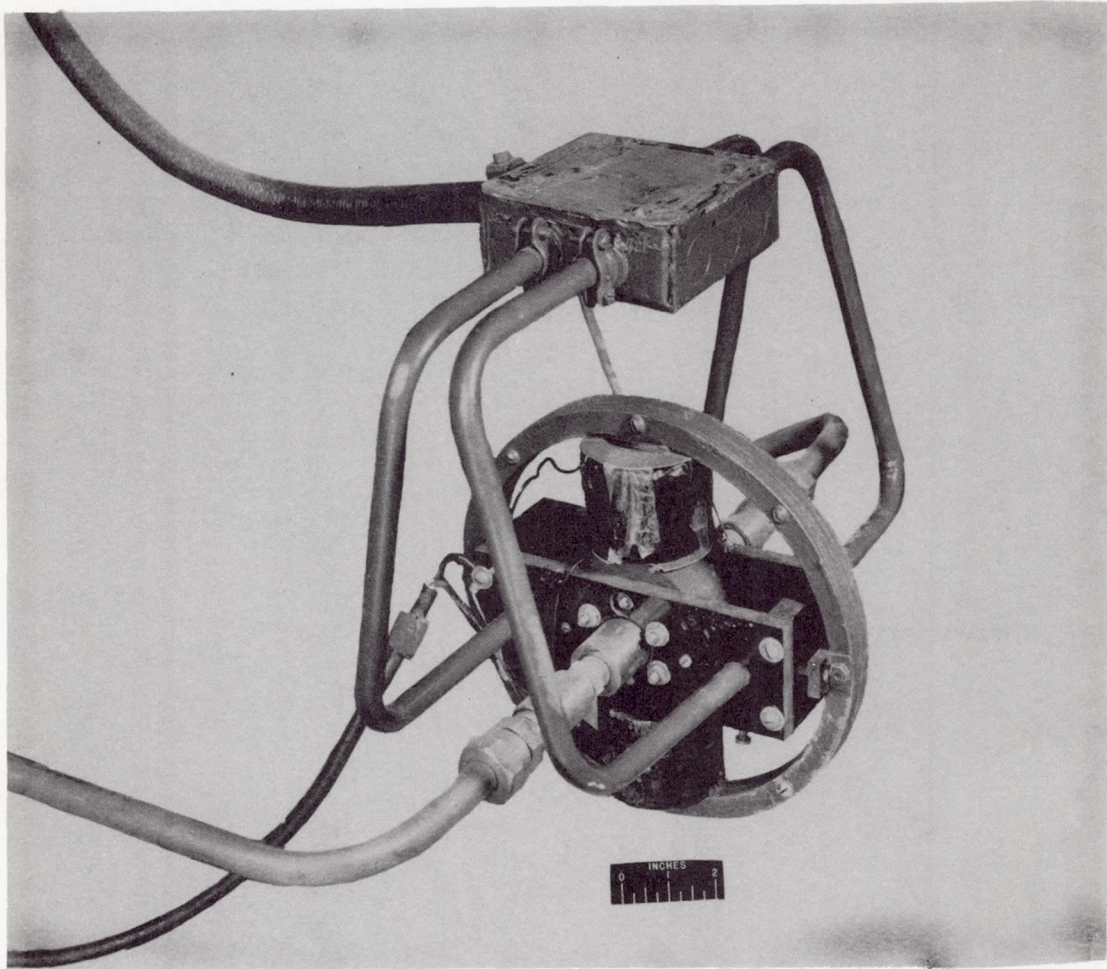
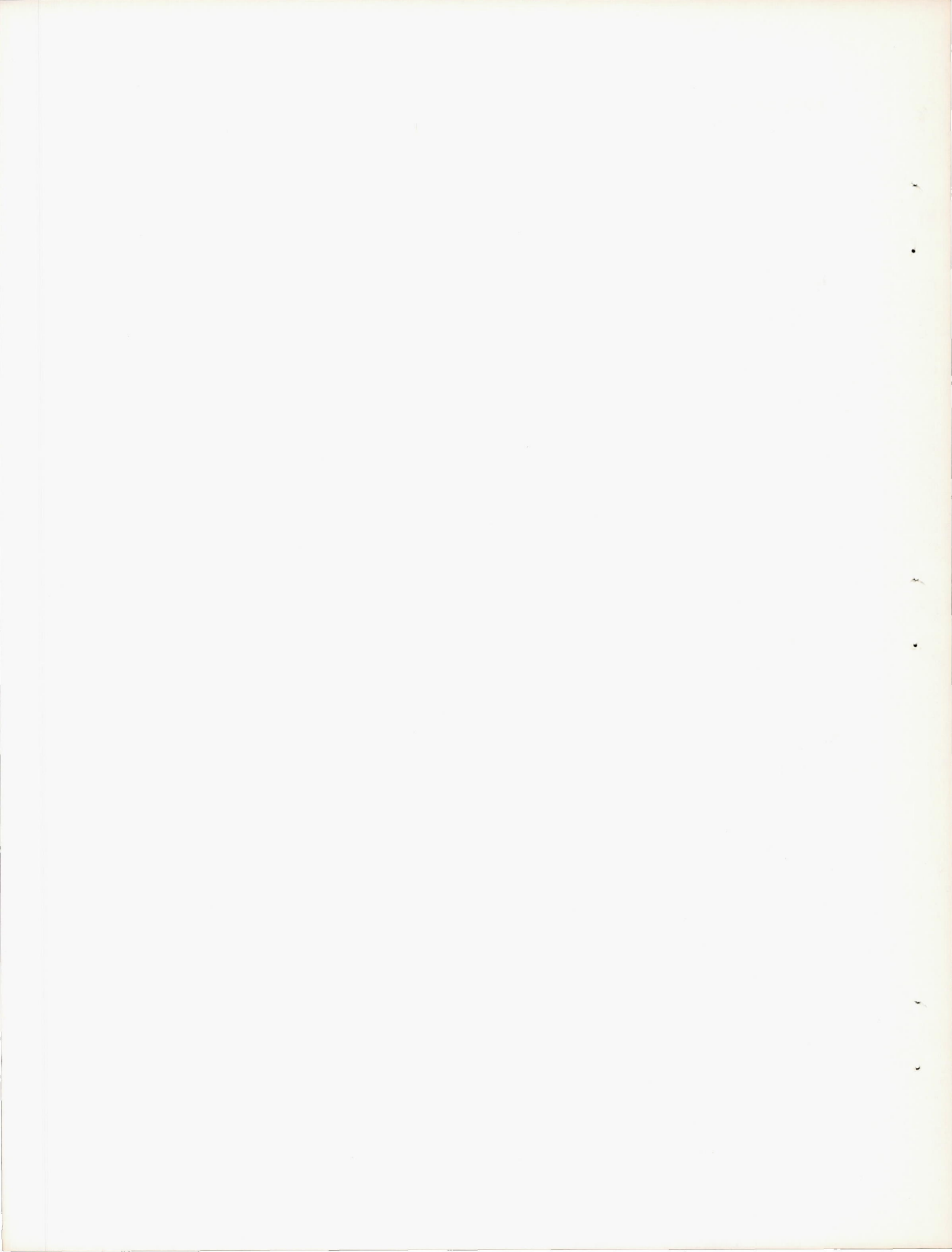

Figure 3. - Electromagnetic flowmeter.

C-25852



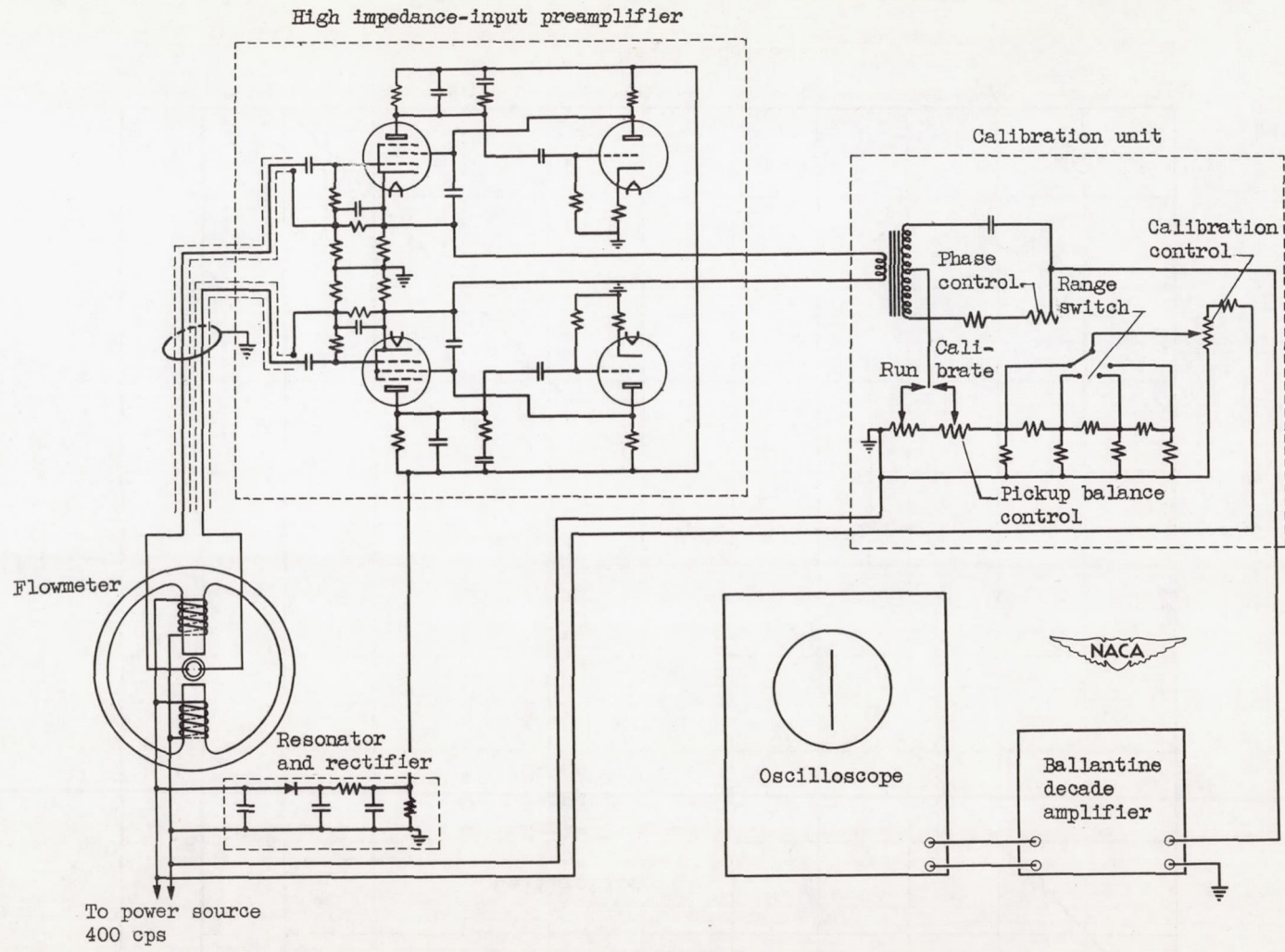

Figure 4. - Circuit diagram of electromagnetic flowmeter.

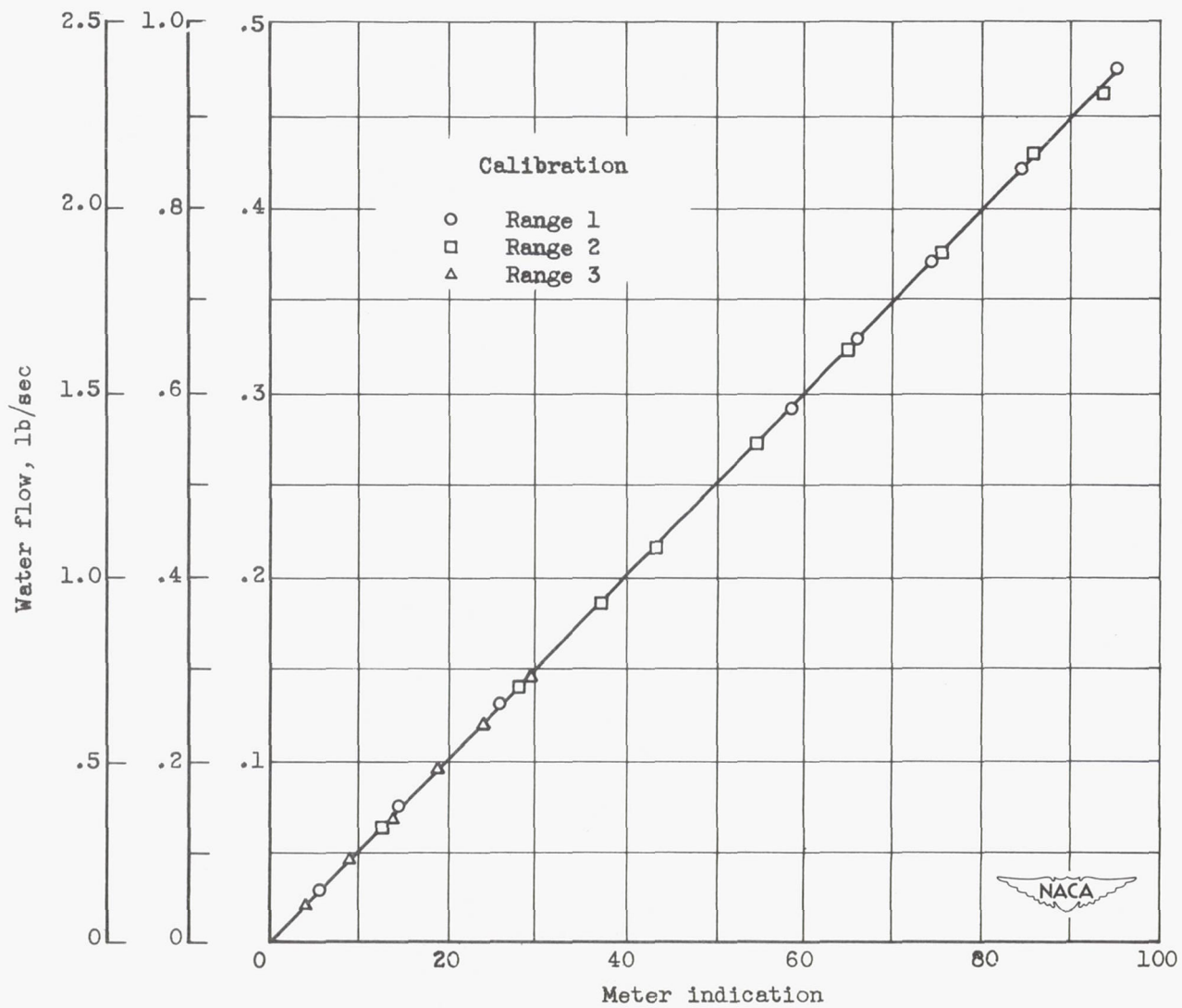

Figure 5. - Calibration curve of flowmeter.

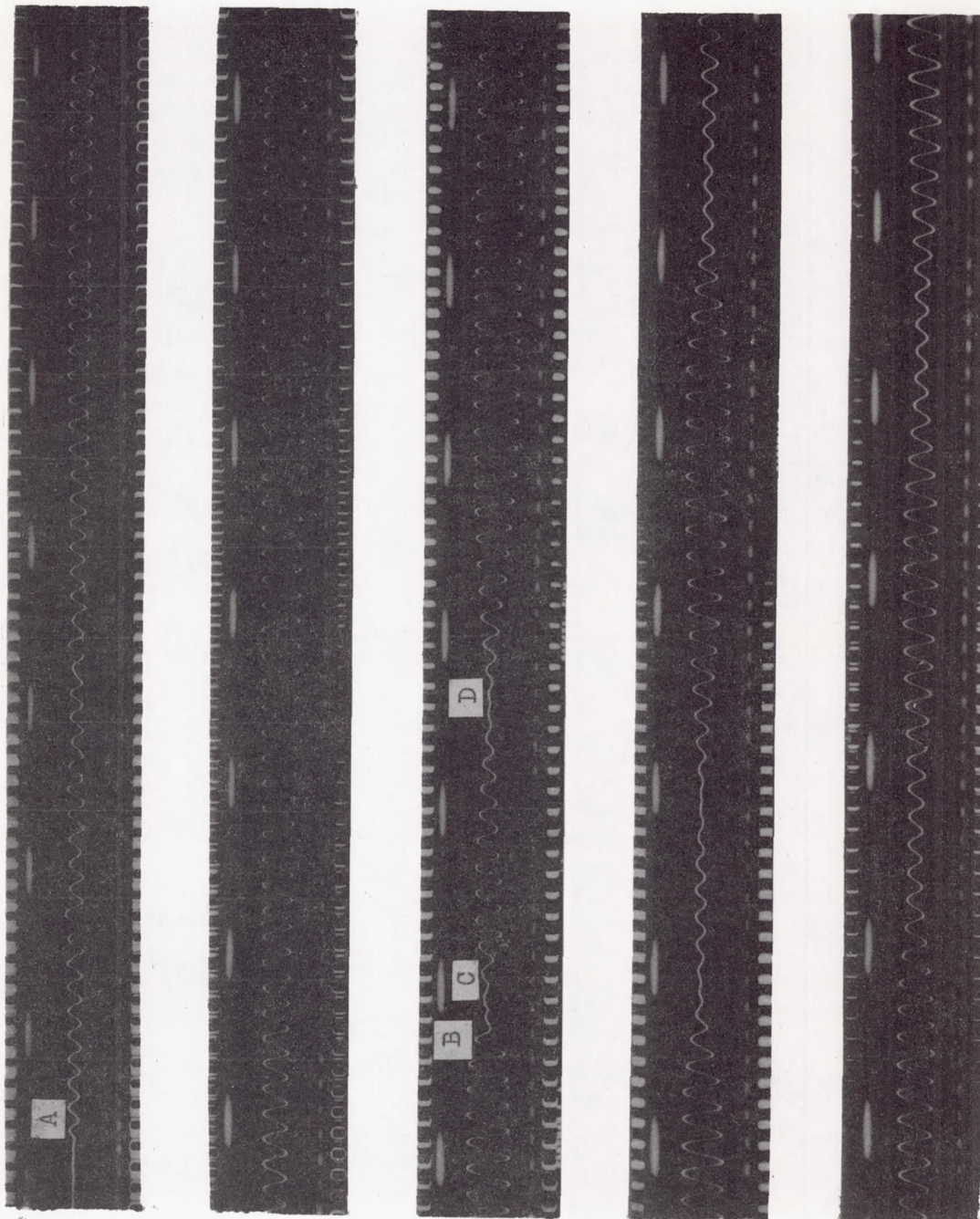
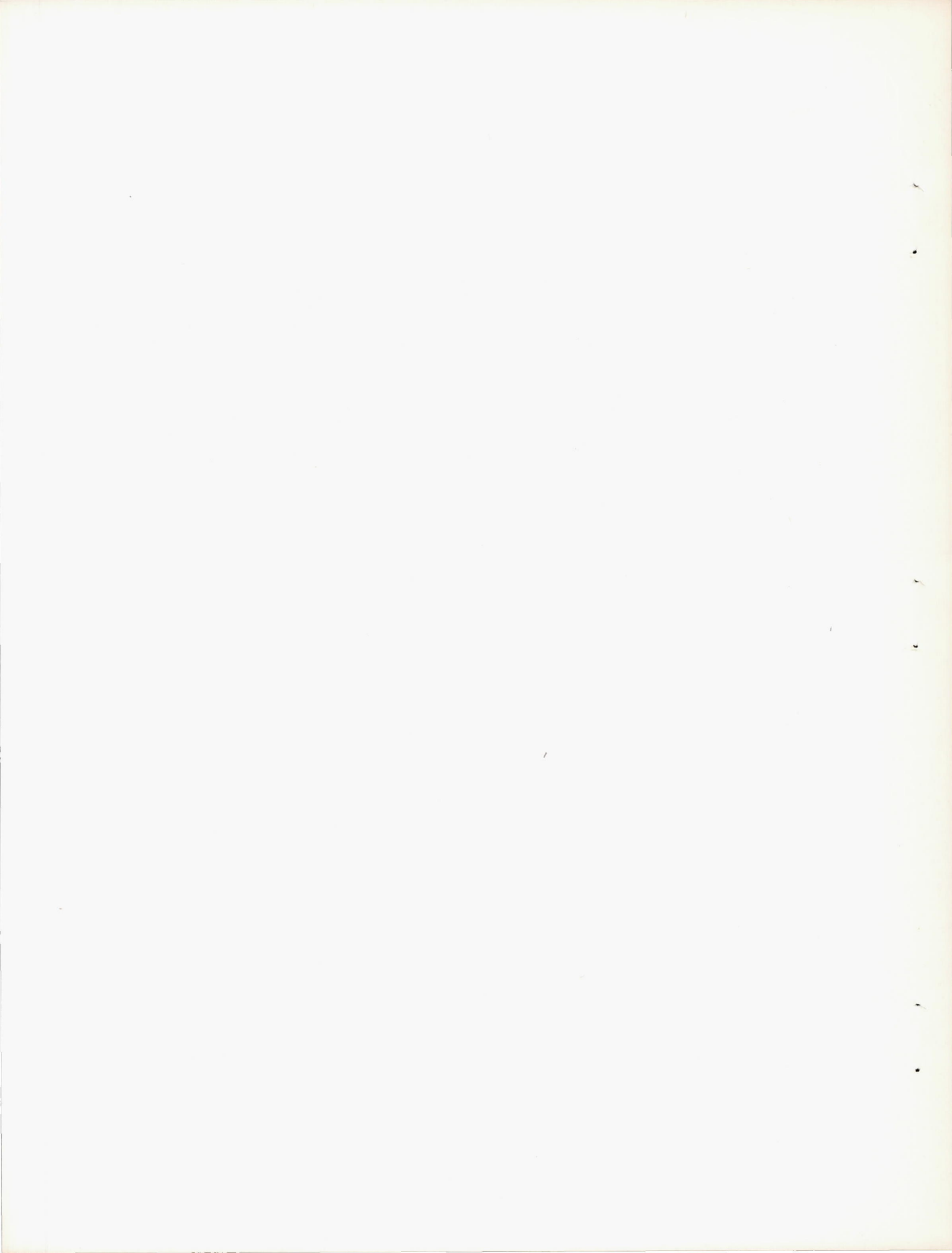
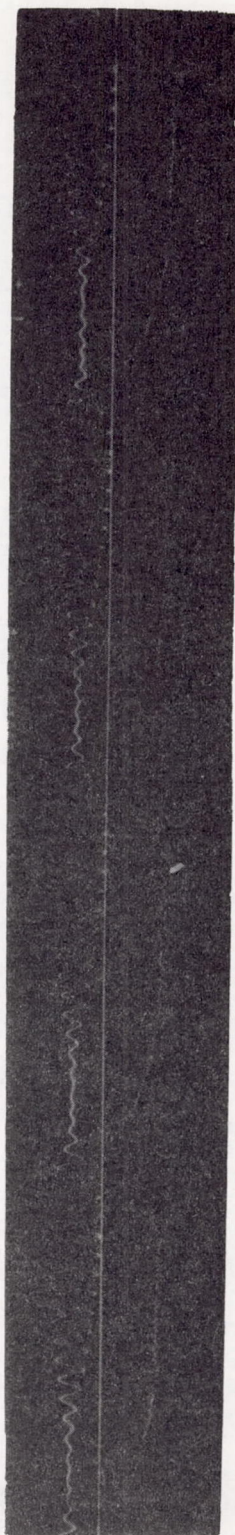

Figure 6. - Meter record of fuel flow to pulsing rocket.

NACA
C-26872





Pulsing rocket



Smooth running rocket

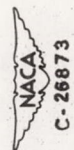

Figure 7. - Comparison of fuel flow and rocket-chamber pressure.