

11

TECHNICAL MEMORANDUMS

NATIONAL ADVISORY COMMITTEE FOR AERONAUTICS.

Library L.M.A.L.
copy 1

No. 282

RESULTS OF EXPERIMENTS WITH SLOTTED WINGS.

By G. Lachmann.

From "Zeitschrift für Flugtechnik und Motorluftschiffahrt,"
May 26, 1924.

FILE COPY

To be returned to
the files of the Langley
Memorial Aeronautical
Laboratory

October, 1924.



NATIONAL ADVISORY COMMITTEE FOR AERONAUTICS.

TECHNICAL MEMORANDUM NO. 282.

RESULTS OF EXPERIMENTS WITH SLOTTED WINGS.*

By G. Lachmann.

Since the first reports of experiments with slotted wings, which demonstrated the practical importance of this new wing form, very little has been published concerning its further development. During the last few years, however, much active research work with slotted wings has been done in England and Germany, both constructively and experimentally. Without doubt it was these investigations which led Handley Page, Ltd. to their very successful and practical employment of slotted wings. In the following pages, I will give some of the results which seem to me of general interest.

1. Effect of Index Value, V_l .

In wind tunnel tests of slotted wings, the effect of the index value V_l , was found to be of extraordinary importance. The investigations of Kumbruch** and Wieselsberger***, as well as those

* From "Zeitschrift für Flugtechnik und Motorluftschiffahrt," May 26, 1924, pp. 109-116.

Editor's Note. - This paper has been in the Editor's hands since November, 1923, but for various technical reasons, could not be published previously. The experimental results here given are, therefore, no longer new and have been partly superseded in more recent investigations. Some later results are yet to be published.

** Kumbruch, "Zeitschrift für Flugtechnik und Motorluftschiffahrt," 1919, Nos. 9 and 10.

*** Wieselsberger, "Ergebnisse der Aerodynamischen Versuchsanstalt zu Göttingen," I Lieferung, S.54.

made in England,* have already shown that the coefficient of maximum lift varies greatly with variations in the index values V_l , especially for thick, highly-cambered airfoils.

The dependence of the maximum lift on the index value V_l , was first clearly demonstrated in slotted wings by experiments with an airfoil of medium thickness 0/100 (Fig. 2). In these experiments, performed in English laboratories, very satisfactory values of C_{Lmax} were obtained. These values were

| Velocity of wind, V | | Index value V_l | C_{Lmax} with slot open | C_{Lmax} with slot closed |
|---------------------|----------|-------------------|---------------------------|-----------------------------|
| m/s | ft./sec. | | | |
| 10.7 | 35.1 | 1600 | 1.790 | 1.256 |
| 24.7 | 81.0 | 3660 | 1.886 | 1.266 |

The same wing section with a chord of 11.2 cm (4.4 in.) and a wind velocity of $V = 30$ m (98.4 ft.)/sec. (that is, $V_l = 3300$), gave a C_{Lmax} of only 1.32 in the large wind tunnel at Göttingen. This chord of 11.2 cm (4.4 in.) was not the one usually employed at Göttingen, but was chosen in this case for certain technical reasons.

A similar section was then constructed with a chord of 20 cm (7.87 in.) and tested at the usual Göttingen index value of $V_l = 6000$. The model had a span of 100 cm (39.37 in.) and, therefore, an aspect ratio of 5. In order to render the results more easily comparable with those of the English laboratory, they were converted, by means of Betz' formulas, to an aspect ratio of 6.

* Reports of the British Advisory Committee for Aeronautics, #415.

To determine a suitable slot section s , slot widths of 4.3 (.169), 4.6 (.181), 5 (.197), 5.3 (.209), 5.6 (.220), 5.8 (.228) and 6.5 mm (.256 in.) were investigated at the angles of incidence at which C_{Lmax} may occur. Table I gives the results. The most favorable width for the slots was found to be 4.6 mm with which a C_{Lmax} of 1.7 was obtained. With increasing width the maximum lift decreased, while the critical angle of attack increased. This phenomenon is probably due to an increase in the angle of attack of the auxiliary wing with respect to the direction of the air flow.

Table I.

Influence of slot width s on C_{Lmax} in an airfoil of section 0/100 ($V_l = 6000$).

| Width of slot s | | C_{Lmax} | Width of slot s | | C_{Lmax} |
|-------------------|------|------------|-------------------|------|------------|
| mm | in. | | mm | in. | |
| 4.3 | .169 | 1.66 | 5.6 | .220 | 1.49 |
| 4.6 | .181 | 1.70 | 5.8 | .228 | 1.46 |
| 5.0 | .197 | 1.60 | 6.5 | .256 | 1.44 |
| 5.3 | .209 | 1.45 | | | |

After determining the best width for the slot, a thorough test was made at the index value, $V_l = 6000$ both with the slot open and with it closed. The slot was closed by rotating the auxiliary wing. The results are shown in Fig. 1. The value of C_{Lmax} with closed slot is in conformity with the English result, but is somewhat below it when the slot is open.

In order to determine the extent of the effect of the index value V_l , the value of C_{Lmax} was further tested at wind speeds of 10 and 20 m (65.6 ft.)/sec., corresponding respectively to the index values V_l 2000 and 4000. In the first case we found $C_{Lmax} = 1.56$; in the second, 1.57. It is to be noted that these values differ considerably from those found on smaller models with an index value V_l 3300. This deviation from Reynolds law may be explained by the fact that one of the models had a rougher surface, with relation to its area, than the other. In fact, a considerable lessening of the effect of the slot was observed on roughening the models with a coating of emery powder. Similar phenomena were observed by Wieselsberger on wings of the usual type.

The same model was used for testing the variation of maximum lift in a turbulent current. Turbulence was induced by means of a wire netting made of 0.75 mm (.03 in.) wire with a mesh of 3 cm (1.18 in.). With this, it was found that C_{Lmax} dropped to 1.65. Previous tests of this kind with small models had shown that turbulence caused a decrease in wing resistance in the same way. This fact was already known as regards normal wing sections. In neither case, however, was there any increase in C_{Lmax} observed. The differences which still existed between the English and German data concerning the maximum lift of a slotted wing section of 0/100 had therefore to be attributed to other complicated influences which were difficult to determine.

These observations afforded the incentive for a still further

investigation of the effect of the index value V_l . Two wing sections were investigated, the above mentioned O/100 and a thin section, R.A.F.15. The former had a chord of 60 cm (23.6 in.), the latter of 64 cm (25.2 in.), with auxiliary wing, and were tested in a two-dimensional flow. The tests were carried out under conditions similar to those utilized by Kumbruch and later by Wieselsberger in their investigations on the effect of the index value, V_l in non-slotted wings. With a wind velocity of 40 m (131.2 ft.)/sec., index values were obtained which very closely approximated the values occurring in the actual process of landing. Hence, it was possible for the investigations of the effect of the index value to cover quite a large range.

Under the conditions mentioned, it was decided not to investigate two components of vertical lift, therefore only the total lift and drag were measured. According to the results, the displacement of the center of pressure is not especially affected by the index value, V_l . Special attention was paid to the investigation of the horizontal component and the strength of the wire.* Generally speaking, wind-tunnel tests are by no means ideal and might be improved in many points. In Germany, however, they are for the present the only available means of making such investigations. Tests made with very small index values, V_l , such as were

* The horizontal component arises from the fact that the wire is not suspended quite vertically.

formerly used at Teddington* with normal airfoils, are only of academic interest and might easily lead the constructor to erroneous conclusions.

Figs. 2, 3, and 4, show the airfoils tested and the manner of making the models. The wings of the small models in use at Göttingen were made of sheet metal covered with plaster of Paris. This was done for economy and also to facilitate the greatest possible accuracy. In order to give the sheet metal the strength required to withstand the air forces, it was reinforced by means of sheet-metal ribs and two spars of gas piping. The plaster was spread on rather thinly, as shown in the illustrations by the cross hatching.

The auxiliary wing of section O/100 was made rotatable, so that the width of the slots could be varied. In the R.A.F. 15, the auxiliary wing consisted of a bent piece of sheet metal and was rigidly attached to the main wing.

Results of Tests with Wing Section O/100.

Experiments were again made for the purpose of determining the best width of slot. Of the three widths tried (12.8 (.504), 16 (.63), and 18 mm (.709 in.)) the best results, as regards maximum lift, were obtained with a width of 16 mm (Table II). Subsequent experiments were therefore carried out with this width of slot.

* British Advisory Committee for Aeronautics Nos. 72, 110, 148, 450 656. Lately, a large V_L index value (24000) has been adopted at Teddington, as the writer had the opportunity of seeing for himself a short time ago. The tests were not carried out in a two-dimensional flow, however, but in a three-dimensional, with an aspect ratio 6.

Table II.

Effect of width of slot s on C_{Lmax} for wing
section 0/100 ($V_L = 24000$).

| Width of slot s | | C_{Lmax} |
|-------------------|------|------------|
| mm | in. | |
| 12.8 | .504 | 1.64 |
| 16.0 | .630 | 1.65 |
| 18.0 | .709 | 1.64 |

Fig. 5 gives the results of the test with open slot at a wind velocity of 40 m (131.2 ft.)/sec. The maximum value of C_L very closely approximates the English result. With regard to the values of C_D , it is to be noted generally that, in consequence of the deflection of the air current, there arises an induced drag, which, as is well known, is inherent in the kinetic energy of the air. A theoretical consideration, on the basis of the theory of sustaining wings, shows that this wing arrangement, with respect to the induced drag, corresponds to a wing with an aspect ratio of 4.4 in an airstream of infinite dimensions.

Previous check tests, however, demonstrated the desirability of employing an aspect ratio of 4.1. This difference probably has something to do with the formation of the boundary layer along the walls. An aspect ratio of 4.1 was therefore adopted for the experiments in question and the results were then adapted to a ratio of 6.

The polar curve which was plotted for the same wing section with a chord of 20 cm (7.87 in.) and a wind velocity of 30 m (98.4 ft.)/sec., is shown in Fig. 5 as a dash line. A comparison of the two curves shows that the drag of the larger surface exceeds that of the smaller up to 1.2. Further on, the two polar curves coincide, but the larger surface still has a somewhat greater lift.

The relation between slot effect and the index value V_l , was thoroughly investigated with values of V_l ranging from 6000 to 30000. In these experiments the model was placed at an angle of attack considerably below the maximum. As the test progressed, the angle of attack was increased slowly and steadily, until the lines of flow were loosened. This effect could be clearly observed on the lift balance.

The results of this test are plotted in Fig. 6, which shows that, when V_l is between 6000 and 23000, C_L remains nearly constant and only begins to decrease slightly when V_l exceeds 25000. The value of C_{Lmax} previously obtained with the small model (chord 20 cm = 7.87 in.) also with $V_l = 6000$, is rather smaller than the value obtained with the large wing. This deviation from the law of similitude is to be ascribed to the instability of the flow in the region of the critical angle of attack. The polar diagram in Fig. 7 gives the data obtained with the slot closed. As compared with the results of the small model test, the drag increases when C_L is below 1. The polar curve for the small model is plotted in dashes in the diagram.

The increase of drag, in spite of the high index value of V_L , which was also observed in the 0/100 wing section, does not agree with the data obtained from tests with normal wing sections, for which, with increasing index value in the region of small and average values of C_L , a decrease in the value of C_L was generally observed.

Any hollows left on the positive-pressure side of the airfoil after the slot was closed, were filled with plaster of Paris so that it corresponded to the airfoil shown in Fig. 4. The polar curve for this airfoil is plotted in diagram 7. It is similar to the polar curve of the Göttingen normal airfoil No. 385, which is itself fairly similar in shape to the airfoil under investigation.

With this airfoil tests were also made on the effect of the index value on the maximum lift. The curve obtained is the lower one in Fig. 6. The figures may, however, be rather too large throughout, owing to the method by which C_{Lmax} was determined. With this wing section it is apparently possible, by cautiously increasing the angle of attack, to retard the separation of the lines of flow. This phenomenon is probably the one described by Bairstow in "Applied Aerodynamics," Chapter VIII, "Dynamical Similarity and Scale Effects."

R.A.F.15.

The wing section illustrated in Fig. 3 was then tested at a wind velocity of 40 m (131.2 ft.)/sec. The polar curve is plotted in Fig. 8. The greatest value obtained for C_L was 1.38. The

The relatively high drag may be ascribed to the thinness of the auxiliary wing.

In the upper of the two lift curves plotted in Fig. 9, we see that there is a decided minimum value in the neighborhood of the index value $V_l = 20000$, while above and below this value, the curve has a decided tendency to rise. In the other lift curve, obtained by a test without an auxiliary wing, the same index value of V_l gives in the same neighborhood, a maximum lift, which decreases with smaller or larger index values of V_l . For $V_l = 20000$ the slot effect reaches a decided minimum, though the general course of the curve seems to argue in favor of increased slot efficiency for high index values. Unfortunately, owing to the structural weakness of the auxiliary wing, it was not possible to make the test at a wind velocity of 50 m (164 ft.)/sec.

The R.A.F.15 wing section tested with an index value of $V_l = 6000$ and without auxiliary wing, showed tolerable agreement with the law of similarity. The value of C_L for the test with a wing chord of 20 cm (7.87 in.) is derived from an earlier comparative test made in the Göttingen laboratory. The slight deviation may be explained on the ground previously mentioned. Fig. 8 gives the polar diagram for the R.A.F.15 wing section without auxiliary wing at a velocity of 40 m (131.2 ft.)/sec. This figure also gives the polar curve of the same section plotted as a result of the above-mentioned test at Göttingen, which was made with a wing chord of 20 cm (7.87 in.) and a wind velocity of 30 m (98.4 ft.)/sec.

The data were kindly placed at my disposal by the Göttingen Laboratory. They are in striking agreement as regards minimum drag and the general course of the polar curves, the only notable difference occurring in the negative and critical values of the angle of attack. For high values of V_l , C_{Lmax} is slightly larger, thus coinciding with the earlier Göttingen tests with thin wing sections.

This test gave a very fine demonstration of the accuracy of the method employed in testing large wings. Very important data were obtained, proving that the use of slots did not bring about a corresponding decrease of lift, as had been found by Wieselsberger and others in tests with thick wing sections. We assume that such a decrease of lift will be found in conjunction with large V_l values in most of the variable wing sections hitherto known, when the camber is greatly increased without the airflow on the side of negative pressure receiving an additional impulse from a secondary flow, as is the case in slotted wings.

2. Influence of Arrangement of Slots.

The Göttingen wing section No. 422, divided into three parts, which served principally for the first experiments on slotted wings, was chosen for this series of tests,* the object of which was to determine the effect of varying the positions of the slots, that is, to find what arrangement of slots would give the smallest coefficient of wing-section drag. The fundamental idea was, first, to find the effect of the arrangement of the separate slots on the
* Lachmann, "Experiments with Slotted Wings," Zeitschrift für Flugtechnik und Motorluftschiffahrt, June, 1921.

coefficient of lift, so that the slots could be placed only where they seemed to be required. Since each additional slot appeared to increase the wing section drag, it seemed obvious that the drag could be diminished by reducing the total space occupied by the slots.

The different slot arrangements tested are illustrated in Fig. 10. They were formed by partially filling up the basic wing section with plaster of Paris. In these tests it was found that about the same value of C_{Lmax} could be obtained with one full-length slot near the leading edge and another shorter one (about 20% of the span) in the center, as with three full-length slots.

When one center and one rear slot were tried, a noteworthy reduction in wing-section drag for small angles of attack occurred, as compared with the effect produced by the forward slot alone. The processes of flow which, in sections with only one slot, cause the sudden increase of drag in the region of small angles of attack, need to be further elucidated. It is certain that they are due entirely to the slot near the leading edge, whereas the slots located further to the rear diminish this increase in the value of drag or eliminate it altogether (Fig. 11).

As regards the lift, these tests proved that, in sections with more than one slot, the camber of the section must be simultaneously increased. Fig. 12 shows a rather thin section with two slots, making a three-part section. This arrangement gave a maximum lift of 2.28. The simplest way to obtain an increase of camber, on

the addition of a second slot, is to attach a flap to the trailing edge, running the whole length of the span and leaving^a nozzle-like slot between the middle section of the wing and the aileron. Fig. 13 gives the results of the tests of the R.A.F.15 wing section with a slot near the leading edge and a slotted aileron.*

From experiments made with various kinds of wing sections, we can, generally speaking, reckon the following increases of lift obtained by means of slots near the leading edge and slotted ailerons.**

| Kind of section | With slot near leading edge | With slotted aileron |
|-----------------|-----------------------------|----------------------|
| Thin | 50% | 40% |
| Medium | 40% | 30% |
| Thick | 35% | 25% |

Much better lift values have since been obtained with thick wings by means of a slot and ailerons. For instance, with a relatively thick wing section intended for a cantilever monoplane, the writer obtained a maximum C_L of 2.92¹ in the position of normal flight, without any increase in the coefficient of drag_x.

3. Reduction of Wing-Section Drag in Normal Flight.

After the question of lift came that of the reduction of wing section drag in normal flight, which is also a question of great

* Lecture by Handley Page on slotted wings, delivered at the International Air Congress, London, June, 1923.

** English data. The values of C_L are for surfaces with an auxiliary wing.

Error in translation of figure.

practical importance. It appears to be an unwritten law of practical aerodynamics that everything which tends to improve lift, increases drag at the same time. With slotted wing sections, it was soon seen to be impossible, when the lift coefficient was small, to reduce the drag to that of the corresponding basic section. Above a certain coefficient of lift, however, the coefficient of drag is smaller in slotted wings than in normal wings. The difference is about $C_D = 1$.

The next method employed for reducing wing-section drag in normal flight was to close the slot by rotating the auxiliary wing. This device was adopted on the English torpedo airplane "Hendley" by means of a hand-wheel and a spiral gear with automatic locking. It seems, however, not only in wind-tunnel tests, but also in bench and flight tests, that the irregularity still existing on the positive pressure side of the wing section, brings about an increase in the coefficient of drag and a corresponding loss of speed. The flight test was so arranged that one start was made with the slot open. In a second flight, the slot opening on the side of positive pressure was covered with plywood.

By reason of these experiments, the device was abandoned in favor of another arrangement in which the auxiliary wing no longer had a section similar to that of a Joukowsky wing, but consisted simply of a curved duralumin plate forming a lateral flap along the front of the main wing, being hinged to the forward spar by means of outriggers rotating about vertical axes.

As previously mentioned, a slot near the trailing edge has hardly any effect on the wing-section drag and therefore need not be provided with a closing device. The rotatable auxiliary wing has the further advantage, that in opening the slot, it balances the displacement of the center of pressure, thus rendering stabilizing fins unnecessary. Recently, with an improved type of rotatable auxiliary wing, the same conditions as to drag were obtained in normal flight, that is, with closed slot, as with the same wing section undivided.

A fundamentally different method of reducing drag in normal flight, when the slots cut the wing into several parts, is to rotate each separate surface in such a way as to change the wing into a multiplane. An example of this is given in Fig. 14, which illustrates how the two-slotted wing section shown in Fig. 12 can be transformed into a triplane. This is, of course, only practicable for very small airplanes, such as racing airplanes of very small span. It is a well-known fact, in high-speed aircraft, that the ratio of induced to total drag is relatively small.

4. Improvement of Control at Low Speeds.

The question of the control of an airplane at low speeds is closely connected with that of reduction of landing speed. The problem is not peculiar to slotted wings, but applies equally to all aircraft for which complete control in landing is necessary. It is also necessary for the safety of all commercial aircraft

landing at low speed. In landing, it has been found that the ailerons first lose their steering power. In order to increase the aileron efficiency, a slot was left between the ailerons and the wing. A series of tests were made with the model represented in Fig. 15. The results of these tests are plotted in Figs. 16 and 17. In Fig. 16 the measurements are taken with the ailerons set at an angle of 10° , the ailerons being with and without slot. The width of the slot was 3.5 mm (.138 in.). Fig. 17 shows the moments for an aileron deflection of 15° , both with and without slot. In the first form of slot its width was 3.5 mm as before. In the second form, the width of the slot was reduced to 2.5 mm (.098 in.). These figures show that when the angle of attack is positive, a greater moment can be obtained with slotted ailerons than with those of the usual type. The moments actually measured are plotted on the diagrams in function of the angle of attack. From the polar diagram in Fig. 18, it is evident that the drag was not affected by the aileron slot. It is a very important fact, and one which argues in favor of slotted ailerons, that with a maximum angle of attack $\alpha = 27^\circ$, no positive moment could be obtained with normal ailerons, though it was obtained with slotted ailerons. ("Positive" here denotes the direction of a moment which tends to right an airplane.) With the usual type of aileron, on the contrary, there was a reversal of the desired effect, which, in actual flight, might have caused the airplane to roll. Simultaneously with the measurement of the rolling moment, the moments arising from the motion of the ailerons about

the Z axis of the airplane were measured. The method employed, illustrated in Figs. 19 and 20, did not, however, prove entirely satisfactory, and therefore the results will not be published. Considered qualitatively, however, they confirm the already known fact that the operation of the ailerons, whether of the usual type or slotted, will introduce a negative moment of yaw, forcing the airplane to assume a curved line of flight and imparting a tendency to turn over. The appearance of the negative lateral moment through the deflection of the ailerons may be explained by the fact that, on the side on which the aileron is lowered, the angle of attack of the airfoil is increased, thereby bringing about a redistribution of the lift. On this side there is a greater lifting force, involving a greater induced drag. The appearance of this aileron moment was especially observed in the Rhön flights, on gliders having a large span. An effective remedy for this negative moment might be found in the application of differential ailerons.

The failure of non-slotted ailerons, in the region of the maximum angle of attack, is attributable to the increase in this angle on the side on which the aileron is lowered and the resulting deflection of the air flow. It appears probable that there is a connection between this phenomenon and the gradual loss of pressure on the elevator control in landing. If, for instance, the pilot counterbalances a lateral gust by operating the ailerons while flattening out at a high angle of attack, he may find himself in the condition of stalled flight. Should this occur, then, according to

Hopf's theory, the action of the elevator causes the axis of the airplane to rise, ^{but} it also causes a downward inclination of the axis of flight, together with increased falling speed.

For increased aileron efficiency, it was obvious that the opening of the front slot, at angles of attack above 10° to 12° with corresponding improvement in the lift-drag ratio, should depend upon aileron action. Portions of the auxiliary wing near the ends of the main wing were therefore connected with the ailerons in such a way that the lowering of an aileron would bring about the opening of the slot and vice versa. Systematic tests were carried out at Teddington* along these lines and showed that in this way a very effective increase of the moment of roll together with a reduction of the corresponding moment of yaw was possible within the range of large angles of attack. The tests were carried out on a biplane model with thin wing section (R.A.F.15). The ailerons had a width of 0.284 of the wing chord. The effect of the slot and the influence of the ailerons on the moment of roll were first tested separately and then in combination. At the maximum point, the slot effect was of the same order of magnitude as the influence of the ailerons, so that in combined action, the moment was nearly doubled. When the slot was opened, a positive moment of yaw was caused, so that the resulting moment of yaw was very small and even negative under certain conditions. This signified an increase in aileron efficiency.

At an angle of attack below 12° , a reduction of the moment of

* Aeronautical Research Committee: "Some Experiments on a Model Biplane having Slotted Wings," with particular reference to the improvement of lateral control at low speeds, by H. B. Irving, B.Sc. and A. S. Batson, B.Sc. - R. and M. No. 856, February, 1923.

roll was noted when the slot was open, but this effect was negligible as compared with the effect of the aileron. Furthermore, in the English results, it should be noted that the form of slot was apparently not very favorable since the increase of lift was only 26%. From the results of tests with slotted ailerons, it seems very probable that the efficiency of the device can be still further improved. We can easily see that the high speeds attainable with slotted wings are closely connected with the question of controllability at low speeds. If constant control is to be assured, the coefficients of the moments, with respect to the decrease in the dynamic pressure, must be reckoned as increasing, not linearly, but as their squares. For instance, if the landing speed is one-half the speed of normal flight, the coefficients of the moments must be multiplied by four, if the same degree of control is desired as before.

The technical data obtained by means of tests have been fully confirmed in actual flight. Therefore, all airplanes with slotted wings are to be constructed with slotted ailerons. The innovation has also been successfully applied to wings of normal section; for instance, to the Handley Page W.8 commercial biplane, and also to the newest type of single-seater pursuit airplanes used in the Swedish army, accompanied by a considerable reduction in the size of the ailerons.

The writer expresses his thanks to Handley Page, Ltd., Cricklewood, London, for their kind permission to publish the above data, the results of experiments made while in their service.

Translated in Paris Office, National Advisory Committee for Aeronautics.

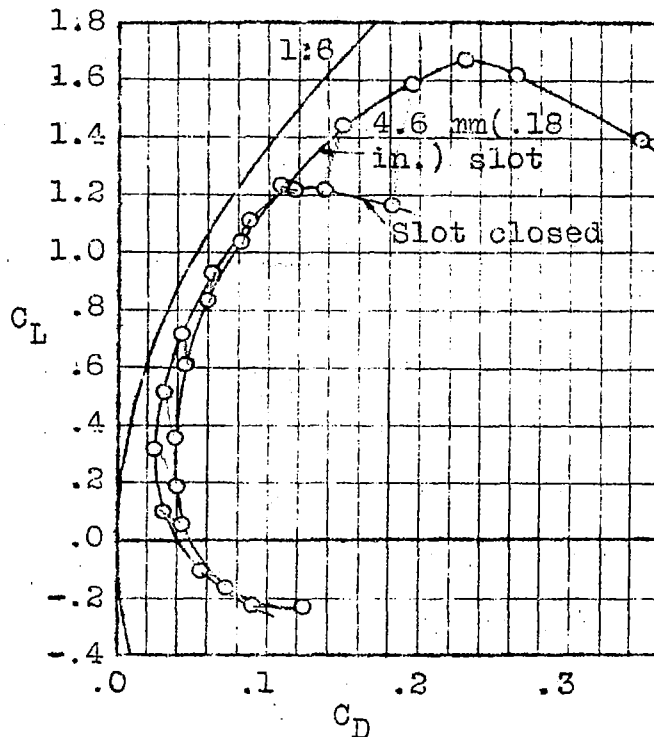
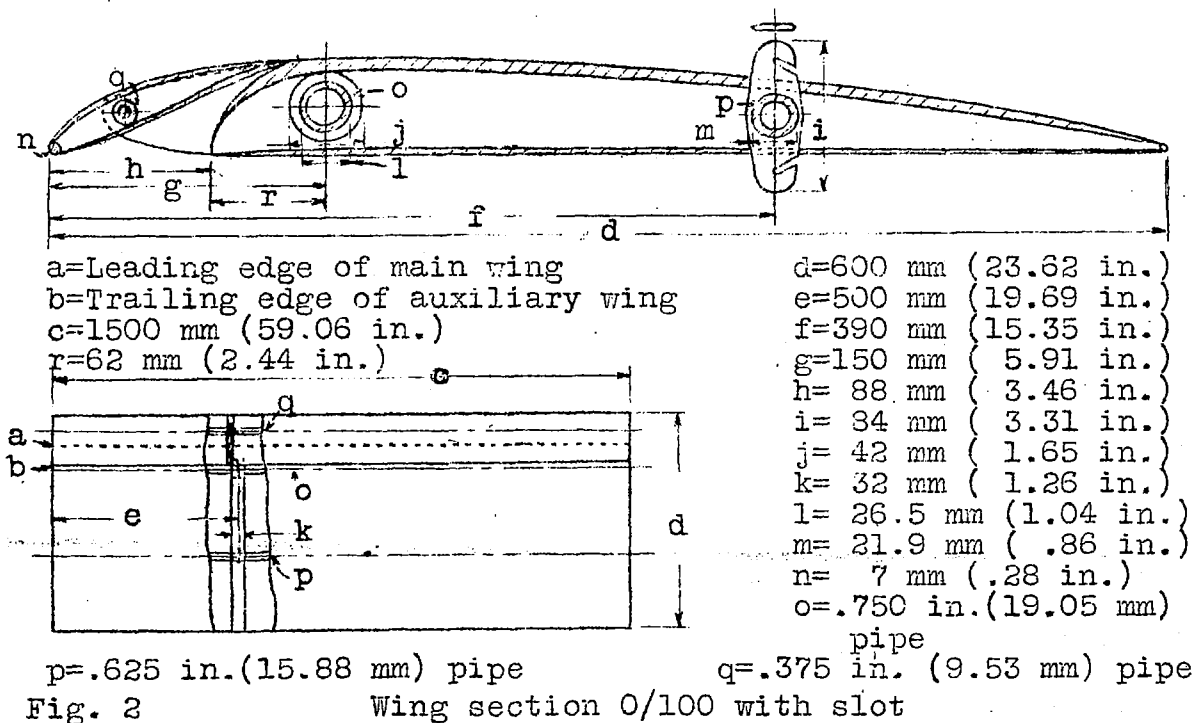
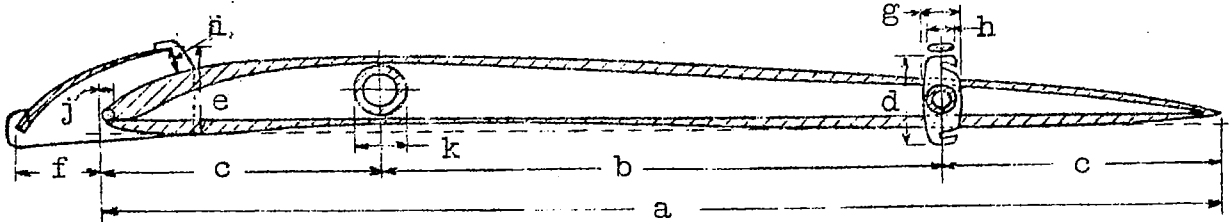

Fig. 1 Wing section O/100 (small model)





- a=600 mm (23.62 in.)
- b=300 mm (11.81 in.)
- c=150 mm (5.91 in.)
- d= 50 mm (1.97 in.)
- e= 47.6 mm (1.87 in.)
- f= 44 mm (1.73 in.)
- g= 21 mm (.83 in.)
- h= 15 mm (.59 in.)
- i= 14.6 mm (.57 in.)
- j= 7 mm (.28 in.)
- k= 26.5 mm (1.04 in.)

Fig. 3 Wing section R.A.F. 15 with auxiliary wing.

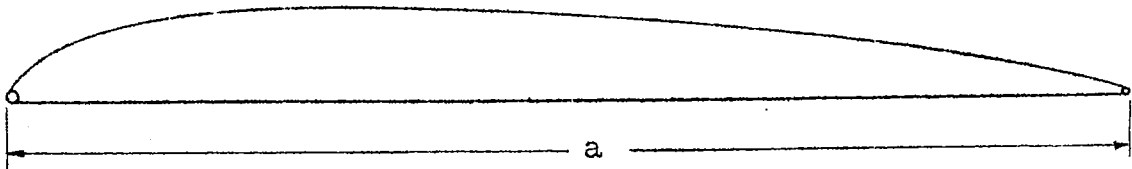

Fig. 4 Wing section O/100 without slots

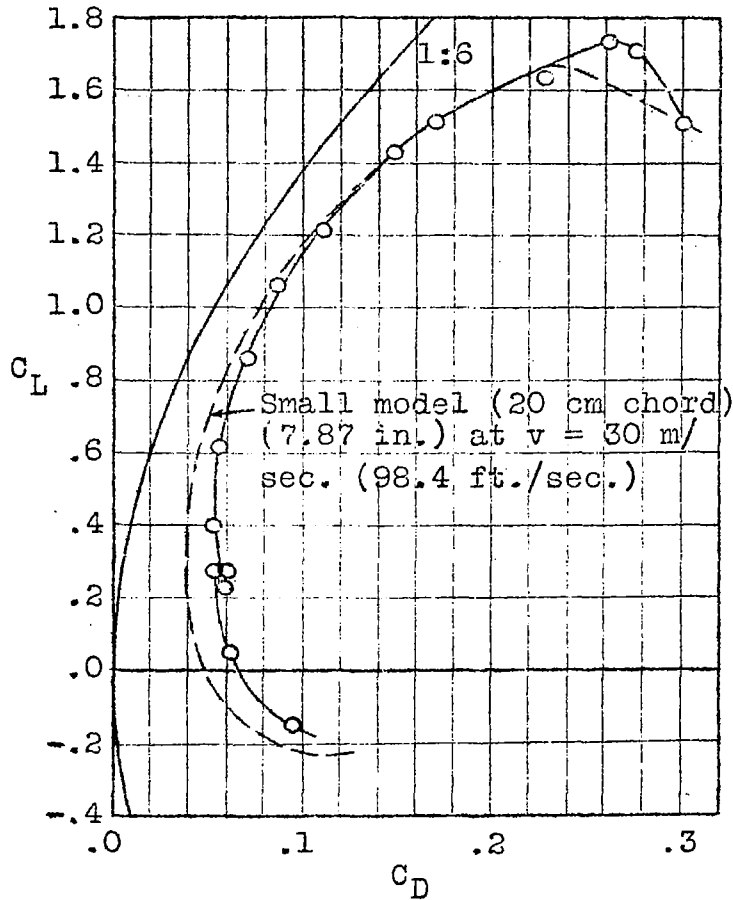

Fig. 5 Wing section O/100 (large model)

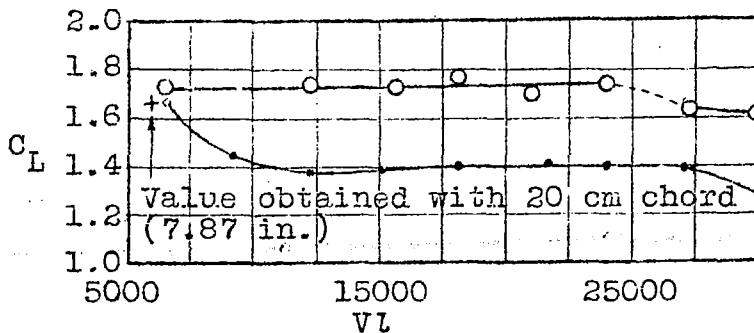

Fig. 6 Wing section O/100 with and without slot and with various index values, V_l

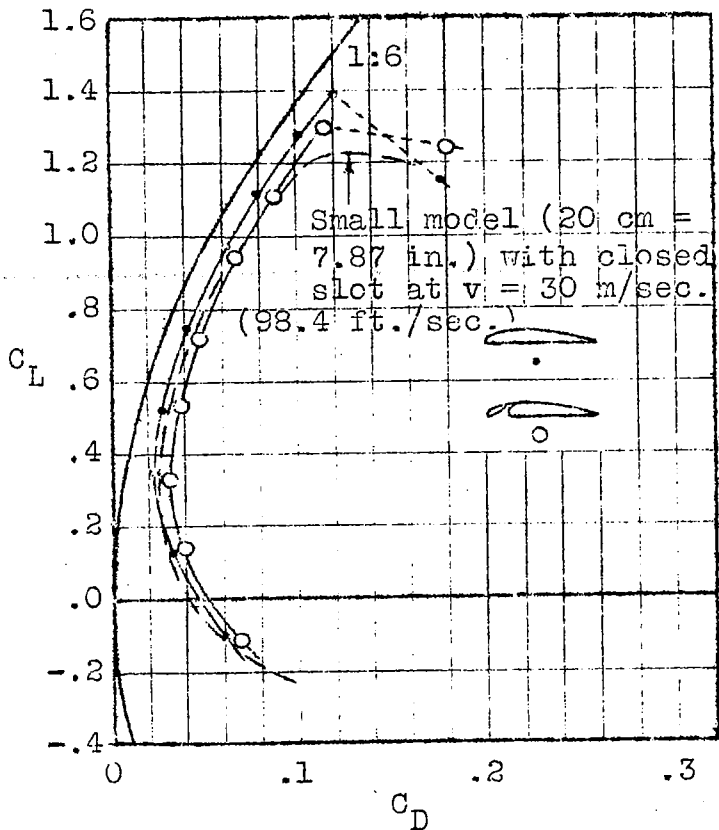

Fig. 7 Wing section O/100 (large model) with closed or stopped-up slot. $v = 40$ m/sec. (131.2 ft./sec.)

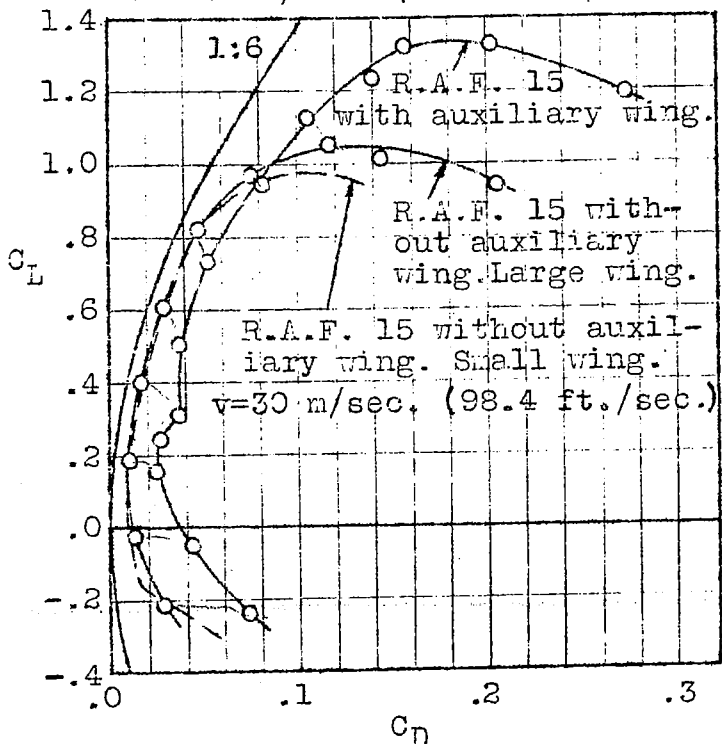

Fig. 8 R.A.F. 15 wing section with auxiliary wing (large model)

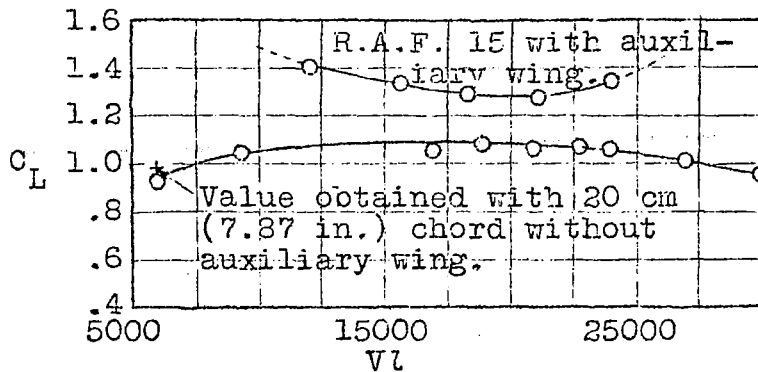

Fig. 9 R.A.F. 15 wing section with auxiliary wing tested at different values of V

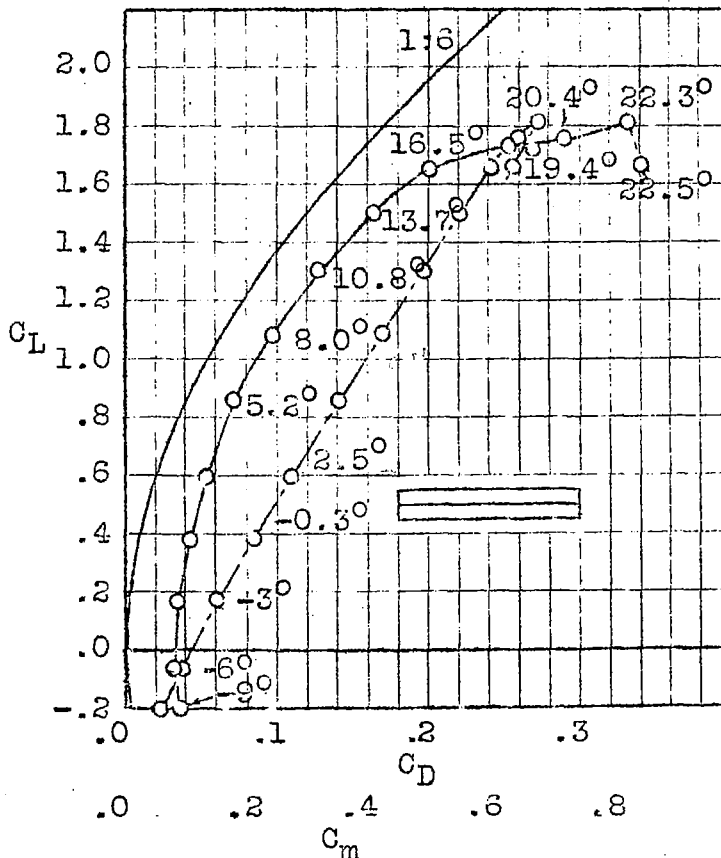

Fig. 11 Wing section No. 422 with center slot.

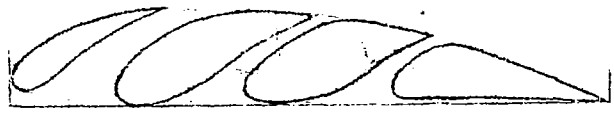
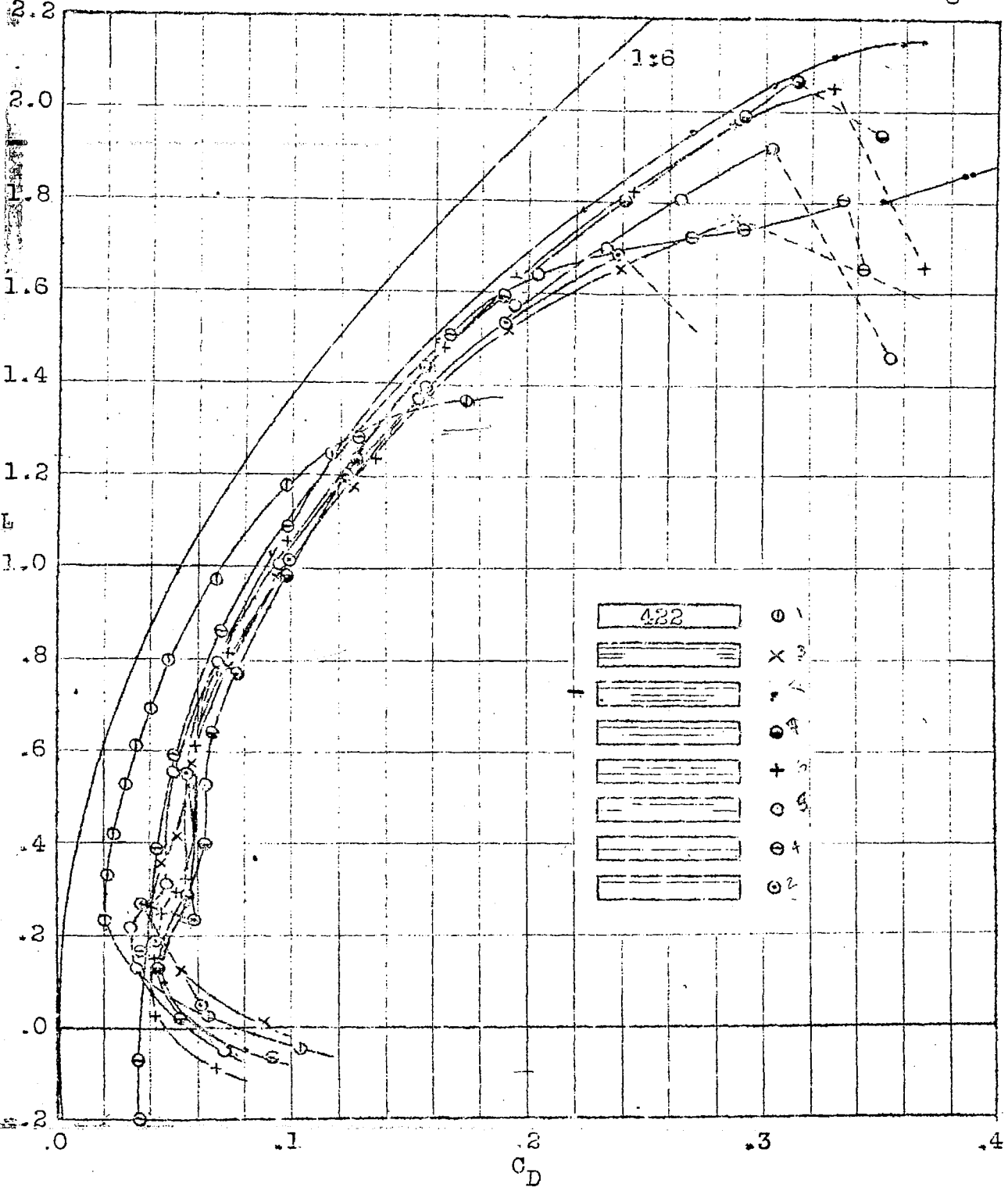
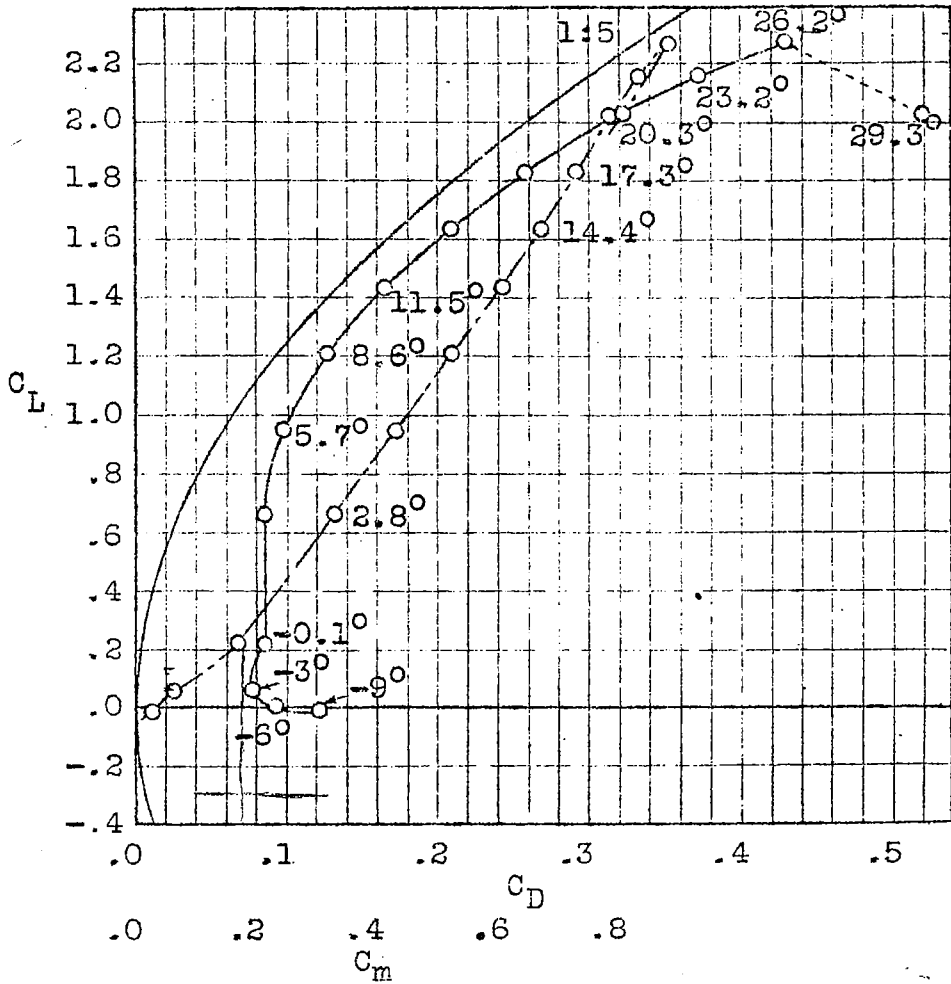

Fig. 10 Wing section No. 422 with different arrangements of slots



2.22

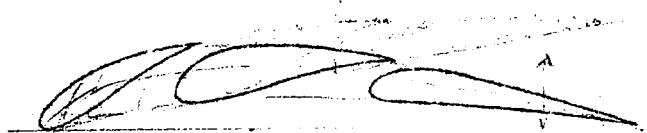

Fig. 12

Wing section with two slots.

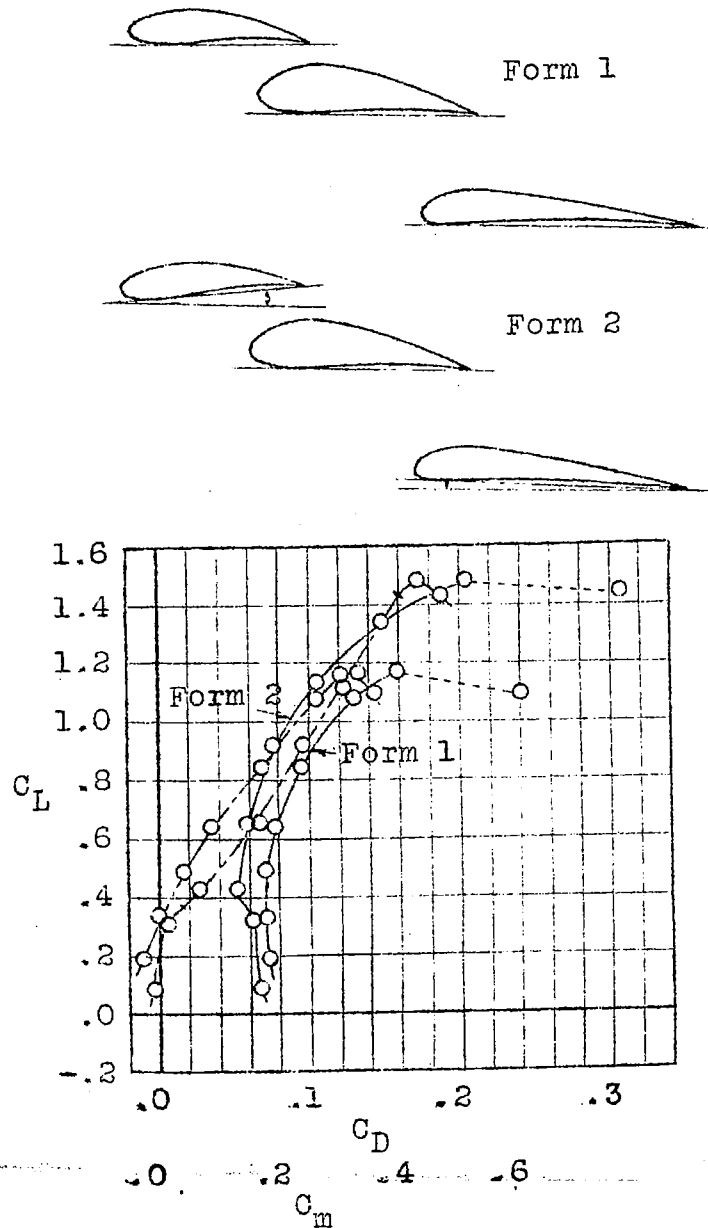

Fig. 14 Conversion of a two-slotted wing section into a staggered triplane

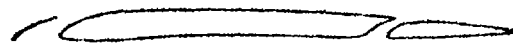
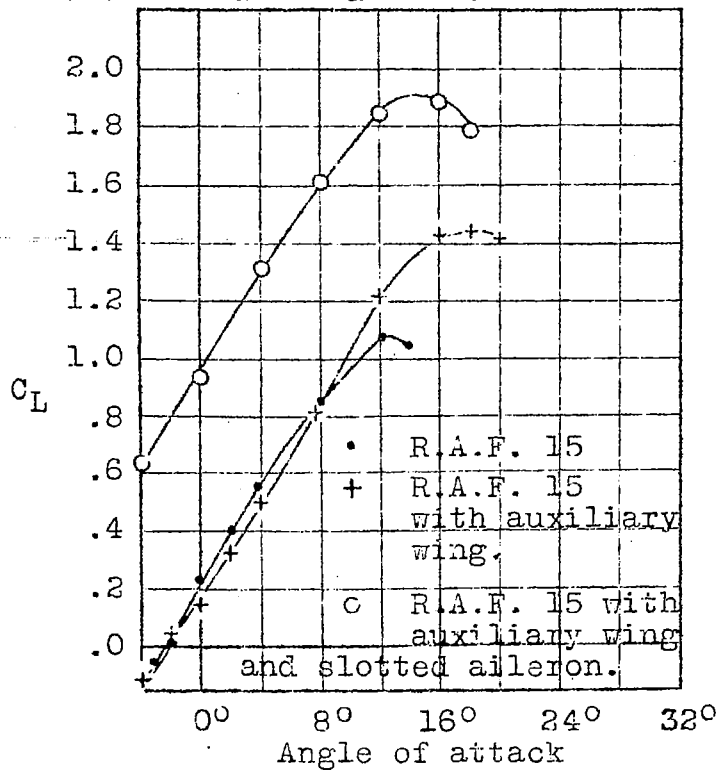

Fig. 13 R.A.F. 15 wing section with auxiliary wing and slotted ailerons.

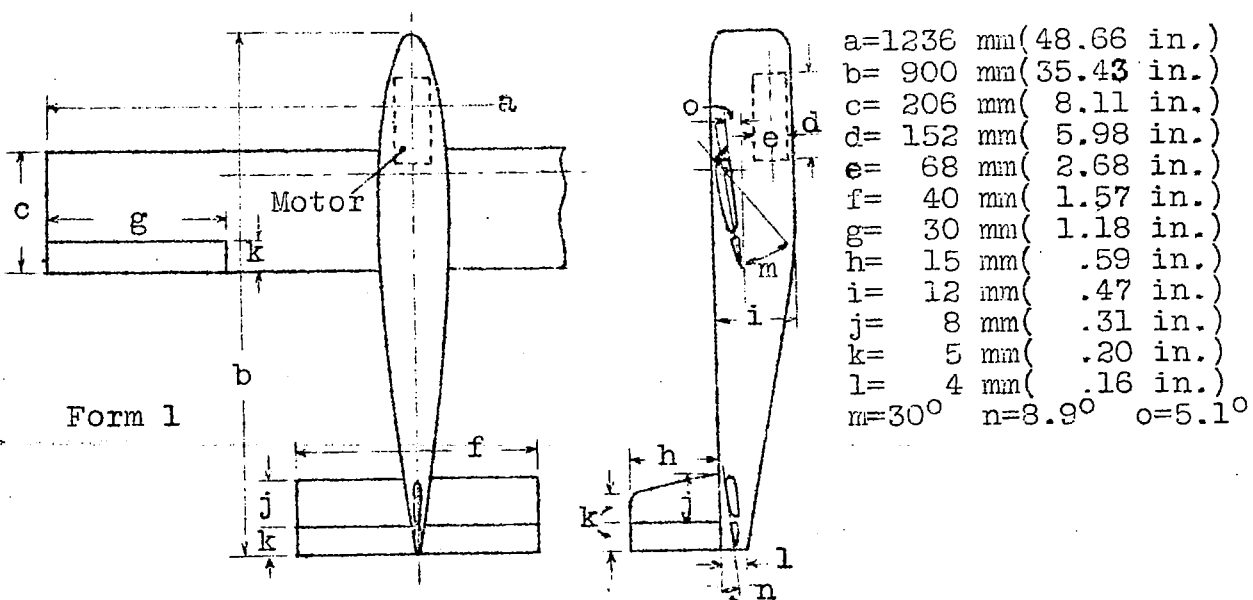

Fig. 15 Model for aileron test

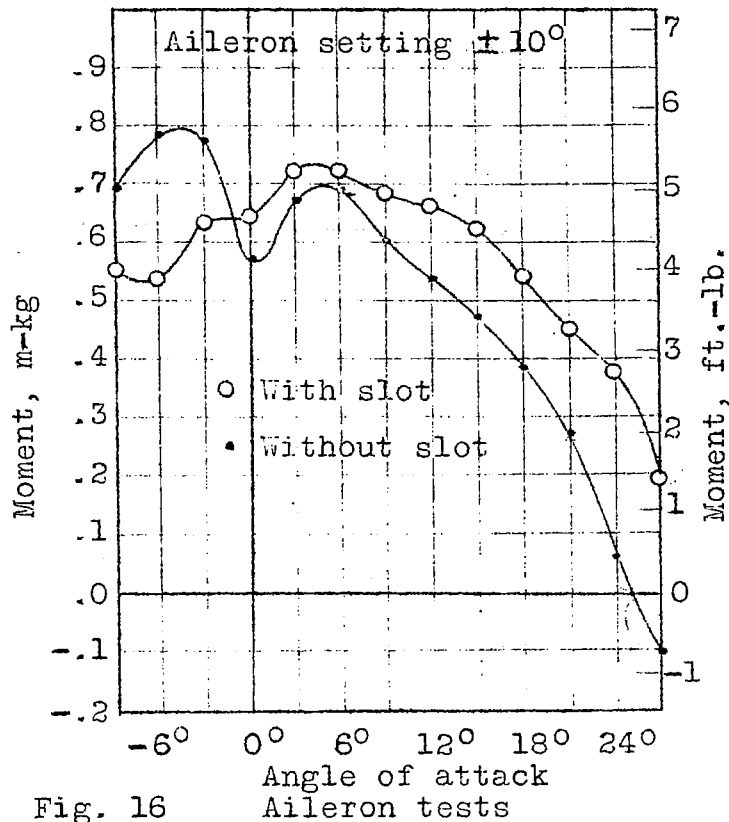

Fig. 16

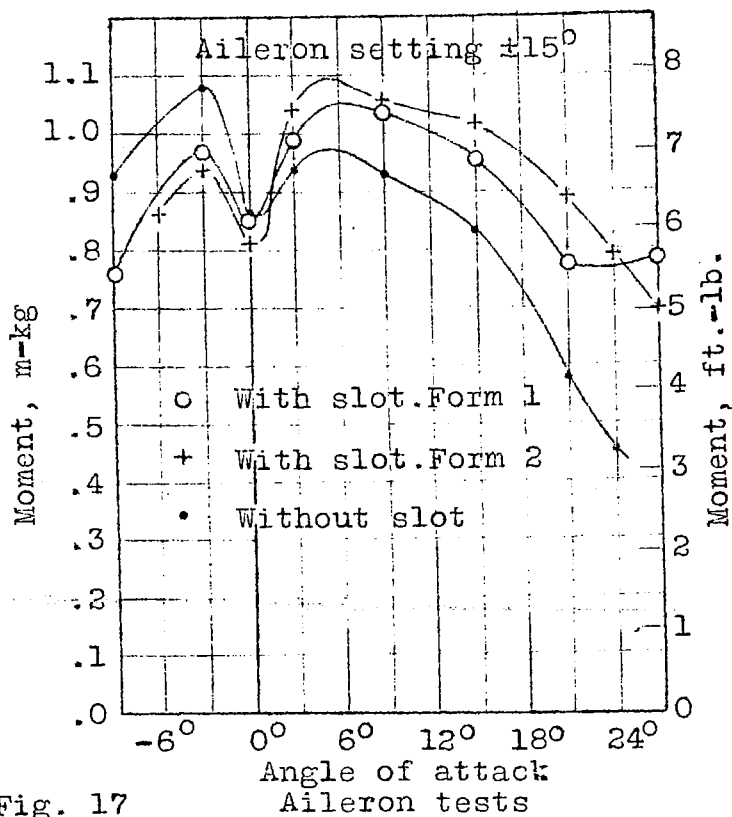

Fig. 17

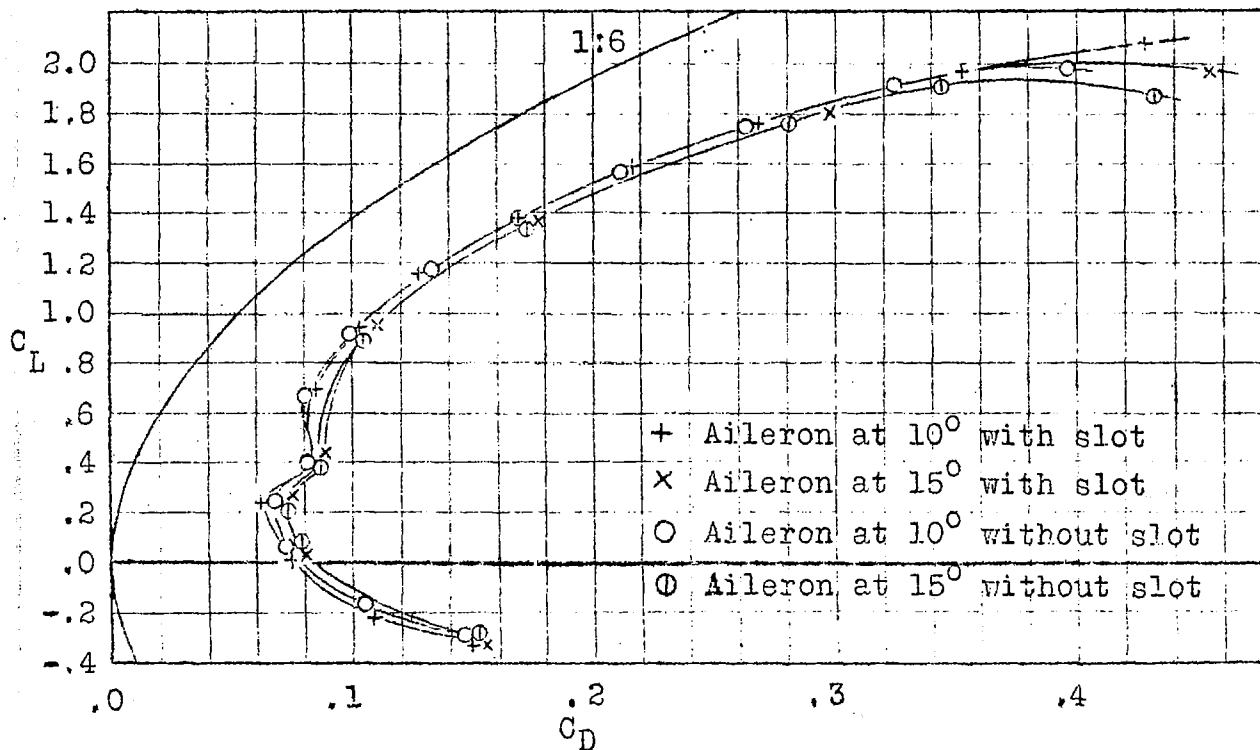

Fig. 18 Polar diagram at various angles of aileron setting.

NASA Technical Library



3 1176 01441 0287