

RESEARCH MEMORANDUM

LARGE-SCALE FLIGHT MEASUREMENTS OF ZERO-LIFT DRAG AT
MACH NUMBERS FROM 0.8 TO 1.6 OF A WING-BODY COMBINATION
HAVING AN UNSWEPT 4.5-PERCENT-THICK WING WITH
MODIFIED HEXAGONAL SECTIONS

By Eugene D. Schult

Langley Aeronautical Laboratory
Langley Field, Va.

NATIONAL ADVISORY COMMITTEE
FOR AERONAUTICS
WASHINGTON

March 23, 1951
Declassified February 10, 1956

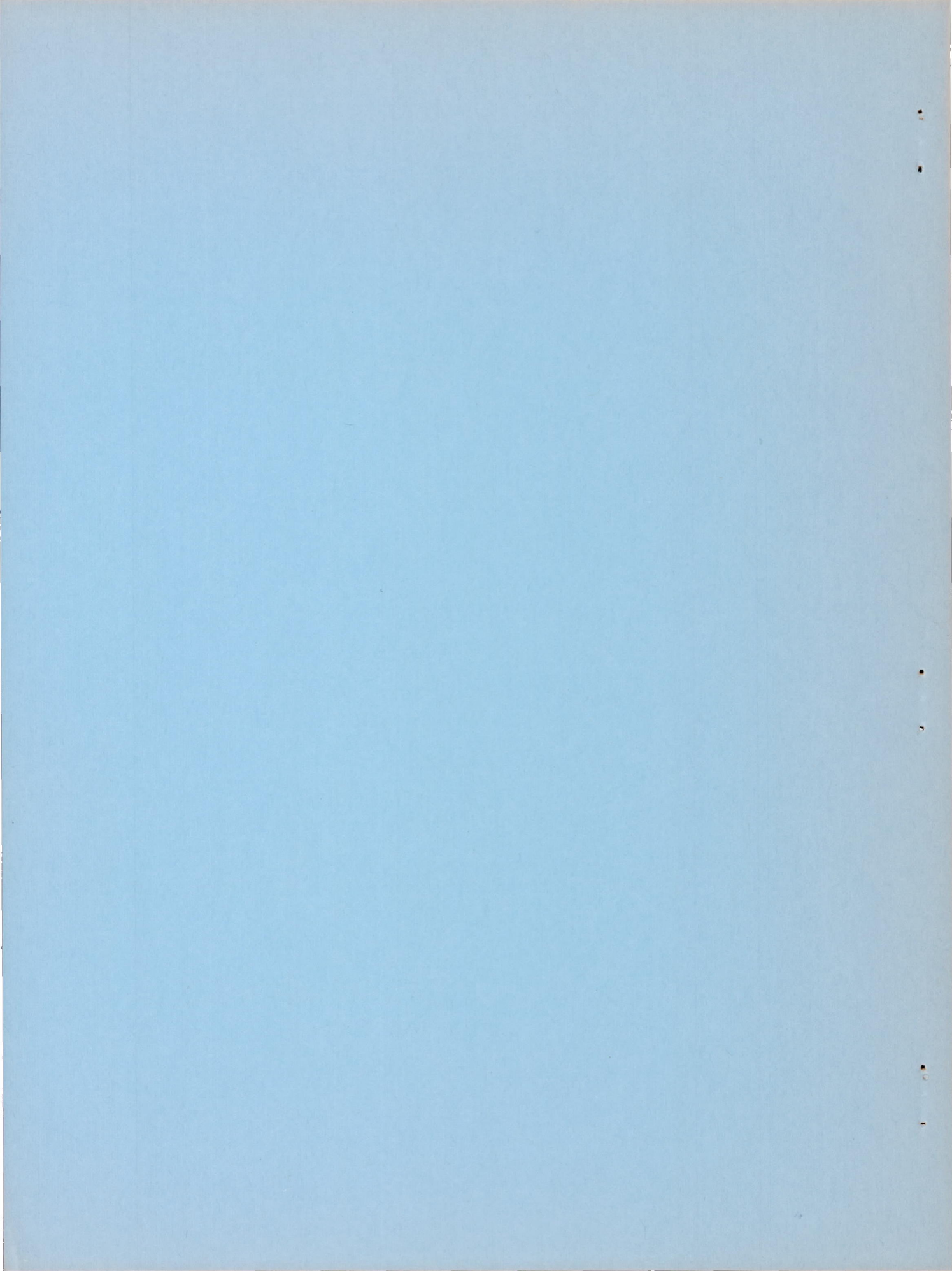

NATIONAL ADVISORY COMMITTEE FOR AERONAUTICS

RESEARCH MEMORANDUM

LARGE-SCALE FLIGHT MEASUREMENTS OF ZERO-LIFT DRAG AT
MACH NUMBERS FROM 0.8 TO 1.6 OF A WING-BODY COMBINATION
HAVING AN UNSWEPT 4.5-PERCENT-THICK WING WITH
MODIFIED HEXAGONAL SECTIONS

By Eugene D. Schult

SUMMARY

An investigation of zero-lift drag of a fin-stabilized wing-body combination was made from high-subsonic to supersonic speeds in the Reynolds number range from 8×10^6 to 24×10^6 . The wing was unswept about the 74.5-percent-chord line, had an aspect ratio of 3.04, a taper ratio of 0.394, and 4.5-percent-thick modified hexagonal airfoil sections. The parabolic-arc body had a fineness ratio of 10 and a frontal area equal to 6.06 percent of the wing-plan-form area.

The results indicate that the total drag coefficient of the winged configuration varied from a minimum value of 0.011 at $M = 0.80$ to a maximum value of 0.035 at $M = 1.03$. Above $M = 1.03$ the drag coefficient decreased approximately linearly to a value of 0.024 at $M = 1.60$, the maximum speed attained. Wing-plus-interference drag coefficients increased from 0.010 to 0.027 in the Mach number interval 0.90 to 0.98, then decreased to 0.013 at a Mach number of 1.60. Winged-body base pressure coefficients were approximately zero up to Mach number 1.2 except for a slight irregularity near Mach number 1.0; above Mach number 1.2 the coefficients became nearly constant at -0.035. The contribution of base drag to the drag of the winged configuration was of the order of 2 percent above Mach number 1.2.

INTRODUCTION

The current program on transonic research conducted by the Langley Pilotless Aircraft Research Division includes zero-lift drag studies of various large-scale rocket-propelled wing-body configurations. These tests, performed under free-flight conditions, are designed to provide

continuous measurements of total drag and base pressure during power-off deceleration from supersonic speeds. Previous results on two wing-body combinations employing 60° delta wings have been reported in references 1 and 2.

As a continuation of the program and because of interest in thin unswept wings, this paper reports the results of a test on a 4.5-percent-thick modified hexagonal section wing of aspect ratio 3.04 mounted on a body of fineness ratio 10.

The Reynolds number of the present test, referred to wing mean aerodynamic chord, varied from 8×10^6 to 24×10^6 . The Mach number range extended from 0.8 to 1.6.

MODELS AND TESTS

Figure 1 illustrates the general arrangement of the present wing-body test combination and shows a typical wing section as well as section details of the solid magnesium tail fins. The wing had an aspect ratio of 3.04, a taper ratio of 0.394, and zero sweep of the 74.5-percent-chord line. The wing sections were 4.5-percent-thick modified hexagonal profiles, and the tips were formed by revolution of the tip sections. Exposed wing area was 80 percent of the total wing area which was 15.26 square feet. Wing construction was of laminated spruce reinforced with dural inlays. The body had a fineness ratio of 10 and a frontal area equal to 6.06 percent of the total wing area. Its profile was formed by two parabolic arcs, each of which had their vertex at the 40-percent body station (maximum diameter). Body coordinates are listed in table I.

Also flown was a wingless body configuration similar to the winged body but having four stabilizing fins. Both models were covered with a polished lacquer finish. The models were propelled by 6.25-inch ABL Deacon rocket motors which had a nominal rated thrust of 5700 pounds for 3.5 seconds. Two photographs of the winged combination are shown in figure 2.

Velocity and acceleration data, obtained with Doppler radar, were reduced to drag coefficients by the method described in reference 3. NACA two-channel telemetering instrumentation provided continuous time histories of longitudinal deceleration and base pressure. These data were resolved into drag coefficients C_D (based on total wing area), base pressure coefficients C_{p_b} , and Mach number M , using radiosonde measurements of ambient atmospheric conditions at the altitude of the test model during flight. Trajectory measurements were obtained with SCR 584 radar.

A detail of the installation of the pressure orifice at the base of the body is given in figure 3.

Reynolds number R is presented as a function of Mach number in figure 4 for the winged body and for the wingless bodies.

Accuracy

The errors in the test results are estimated to be within the following limits:

Mach number	±0.005
Drag coefficient based on total wing area	±0.0005
	±0.005 at $M = 1.6$
Base pressure coefficient	±0.01 at $M = 1.2$
	±0.03 at $M = 0.9$

The aforementioned errors in base pressure coefficient and drag coefficient are mainly of systematic nature; consequently, the trends and variations shown in the data are affected by these errors to only a minor degree.

RESULTS AND DISCUSSION

The present test results are summarized in figure 5 as plots of total drag coefficient, wing-plus-interference drag coefficient, and base pressure coefficient presented as functions of Mach number. Drag coefficients are based on total wing area (15.26 sq ft).

Total Drag

Total drag coefficients reduced from both Doppler radar and telemetered data are shown in figure 5(a) for the test configurations. Also shown is the variation of base drag coefficients obtained from base pressure coefficients presented later in this paper.

The results indicate that the total drag coefficient of the winged configuration varied from a minimum value of 0.011 at $M = 0.80$ to a maximum value of 0.035 at $M = 1.03$. Above $M = 1.03$ the drag coefficient decreased almost linearly to a value of 0.024 at $M = 1.60$. A close examination of the test points at transonic speeds reveals an abrupt "dip" in telemetered measurements at $M = 0.96$; an enlargement of this unique point is presented in figure 6 as a continuous time history of the drag and Mach number. This peculiarity has occurred at

approximately the same Mach number in tests of similar wing-body configurations reported in references 1 and 2. A slight increase in total drag indicated at $M = 1.19$ (fig. 5(a)) can be associated with a similar rise in base drag at this Mach number.

The drag coefficients of the lacquered wingless body with four stabilizing fins are shown in figure 5(a) as a curve faired from Doppler and telemeter test points. These points were generally in better agreement than the points shown for the winged body but have been omitted here for clarity. The drag coefficients of an identical wingless configuration reported in reference 1 are also included in figure 5(a) but modified slightly to account for an error noted in the reduction of telemetered data. The reference model was finished with a preparation of zinc stearate and plastic glue. Of the two finishes the polished lacquer was smoother and the results indicate that it had slightly less drag throughout the Mach number range.

Body base drag coefficients shown for the lacquered configurations were calculated from base edge-pressure data. It was assumed that the differences in pressure across the base were small and for this test would have little effect on the over-all drag coefficients of the combination. Winged-body base drag coefficients were small, never exceeding 2 percent of the total drag over the Mach number range.

Wing-Plus-Interference Drag

The wing-plus-interference drag coefficient curve shown in figure 5(b) represents the increment between the drag of the winged configuration and the drag of the lacquered wingless configuration (less the drag of two fins). The drag of two fins was obtained from unpublished experimental results which show coefficients, based on total wing area, increasing from 0.0013 at high-subsonic speeds to 0.0016 at Mach number 1, then decreasing to 0.0015 at supersonic speeds.

The results indicate that the wing-plus-interference drag coefficients increase from 0.010 at $M = 0.9$ to 0.027 at $M = 0.98$, then decrease to 0.013 at $M = 1.60$.

Also shown in figure 5(b) are calculated values of wing drag coefficient, which are summations of calculated pressure and friction drag of the exposed wing surfaces referred to total included wing area. The approximate pressure drag was determined from the theory of reference 4 by assuming the body to form a reflection plane at the wing root and neglecting the small degree of sweep of the plan form. The friction drag was obtained from theory (reference 5) which accounts for the effect of compressibility and assumes turbulent boundary-layer flow

from the wing leading edge. The calculated results indicate the interference drag to be of small magnitude at supersonic speeds.

Base Pressure

The variation of base pressure with Mach number is given in figure 5(c) for the winged body and the two wingless bodies through the same range of Reynolds numbers (fig. 4). The coefficients for the wingless bodies agreed throughout the Mach number range. Winged-body base pressure coefficients were approximately zero up to a Mach number of 1.2 except for a slight irregularity near Mach number 1.0; above Mach number 1.2 the coefficients became nearly constant at -0.035 .

CONCLUDING REMARKS

A free-flight investigation of zero-lift drag of a tapered, unswept, 4.5-percent-thick wing of aspect ratio 3.04 was made at high Reynolds numbers for the Mach number range from 0.8 to 1.6. Total winged-body drag coefficient increased from 0.011 at $M = 0.8$ to 0.035 at $M = 1.03$ then decreased to 0.024 at $M = 1.6$. Wing-plus-interference drag coefficients varied from 0.010 to 0.027 in the Mach number interval 0.90 to 0.98, then decreased to 0.013 at $M = 1.6$. The base pressure coefficients for the winged configuration were approximately zero up to a Mach number of 1.2 except for slight variations near Mach number 1.0; above Mach number 1.2 the coefficients became nearly constant at -0.035 . The base drag constituted approximately 2 percent of the over-all drag of the winged configuration above a Mach number of 1.2.

Langley Aeronautical Laboratory
National Advisory Committee for Aeronautics
Langley Field, Va.

REFERENCES

1. Nelson, Robert L.: Large-Scale Flight Measurements of Zero-Lift Drag at Mach Numbers from 0.86 to 1.5 of a Wing-Body Combination Having a 60° Triangular Wing with NACA 65A003 Sections. NACA RM L50D26, 1950.
2. Schult, Eugene D.: Comparison of Large-Scale Flight Measurements of Zero-Lift Drag at Mach Numbers from 0.9 to 1.7 of Two Wing-Body Combinations Having Similar 60° Triangular Wings with NACA 65A003 Sections. NACA RM L50I22, 1950.
3. Morrow, John D., and Katz, Ellis: Flight Investigation at Mach Numbers from 0.6 to 1.7 to Determine Drag and Base Pressures on a Blunt-Trailing-Edge Airfoil and Drag of Diamond and Circular-Arc Airfoils at Zero Lift. NACA RM L50E19a, 1950.
4. Nielsen, Jack N.: Effect of Aspect Ratio and Taper on the Pressure Drag at Supersonic Speeds of Unswept Wings at Zero Lift. NACA TN 1487, 1947.
5. Van Driest, E. R.: Turbulent Boundary Layer for Compressible Fluids on an Insulated Flat Plate. Rep. No. AL-958, North American Aviation, Inc., Sept. 15, 1949.

TABLE I
BODY COORDINATES

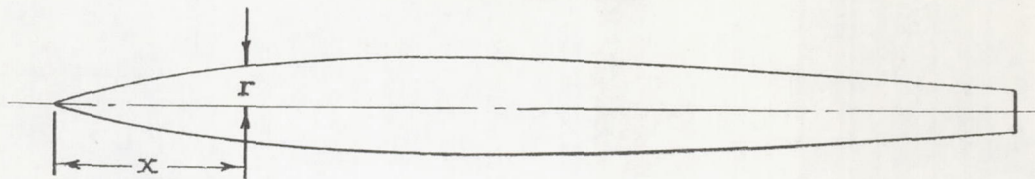

Body Coordinates In Inches

130-inch parabolic body			
x	r	x	r
0	0	54.60	6.496
.78	.194	62.40	6.442
1.17	.289	70.20	6.322
1.95	.478	78.00	6.137
3.90	.938	85.80	5.886
7.80	1.804	93.60	5.570
11.70	2.596	101.40	5.188
15.60	3.315	109.20	4.742
23.40	4.534	117.00	4.229
31.20	5.460	124.80	3.652
39.00	6.094	130.00	3.230
46.80	6.435		

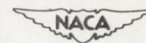

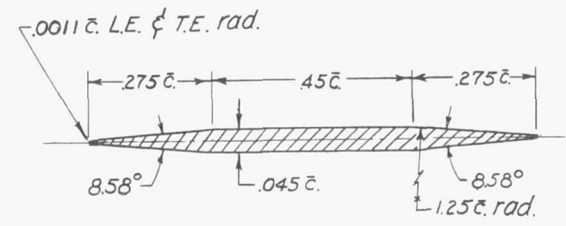
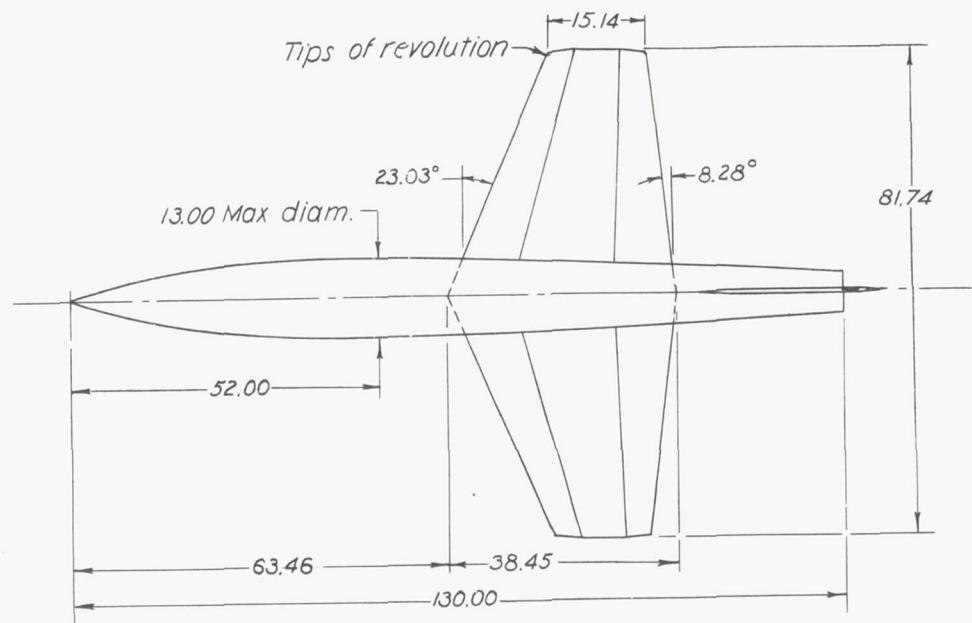

Streamwise wing profile expressed in percent chord

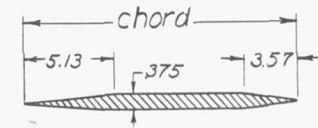

Typical streamwise fin section

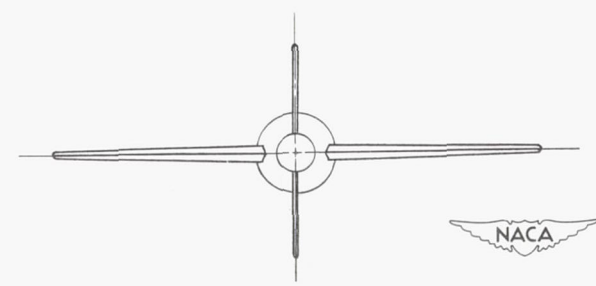
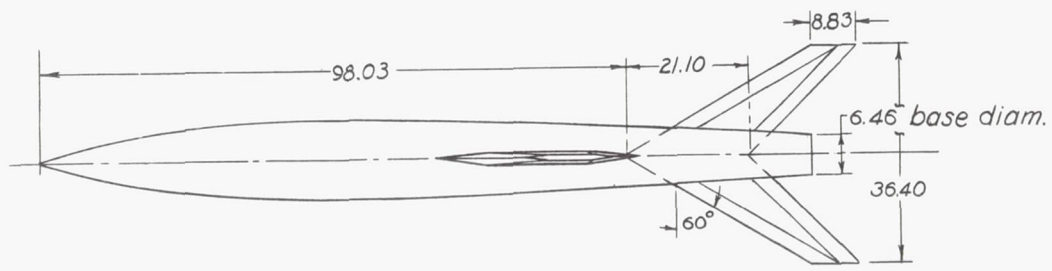

Figure 1.- Geometric arrangement of the test configuration. Dimensions are in inches except as noted.

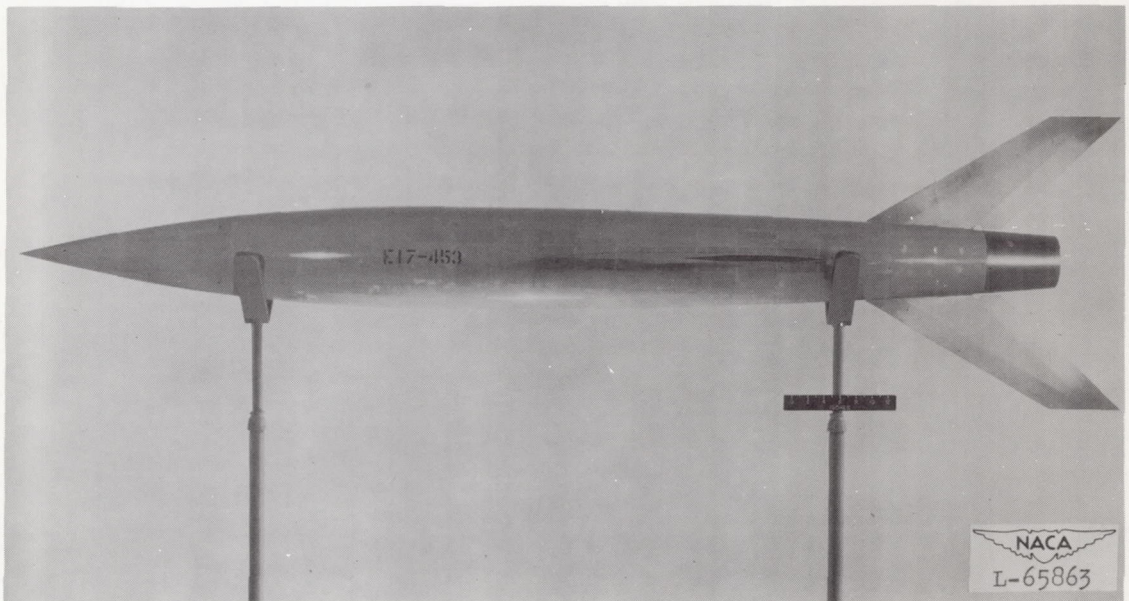
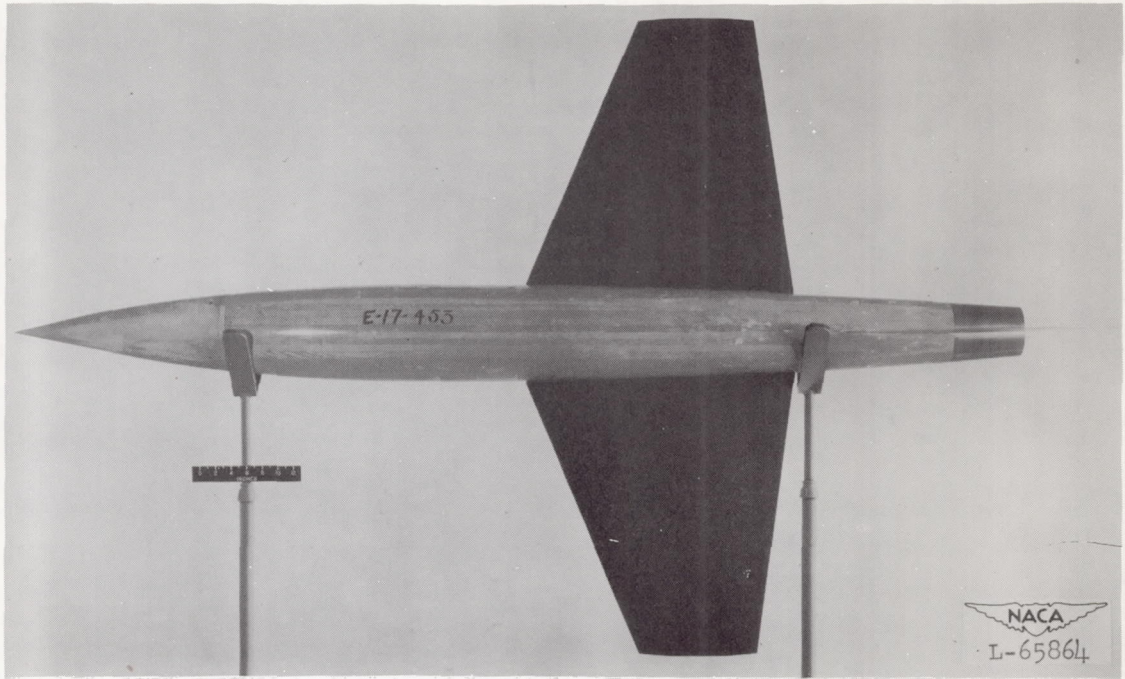
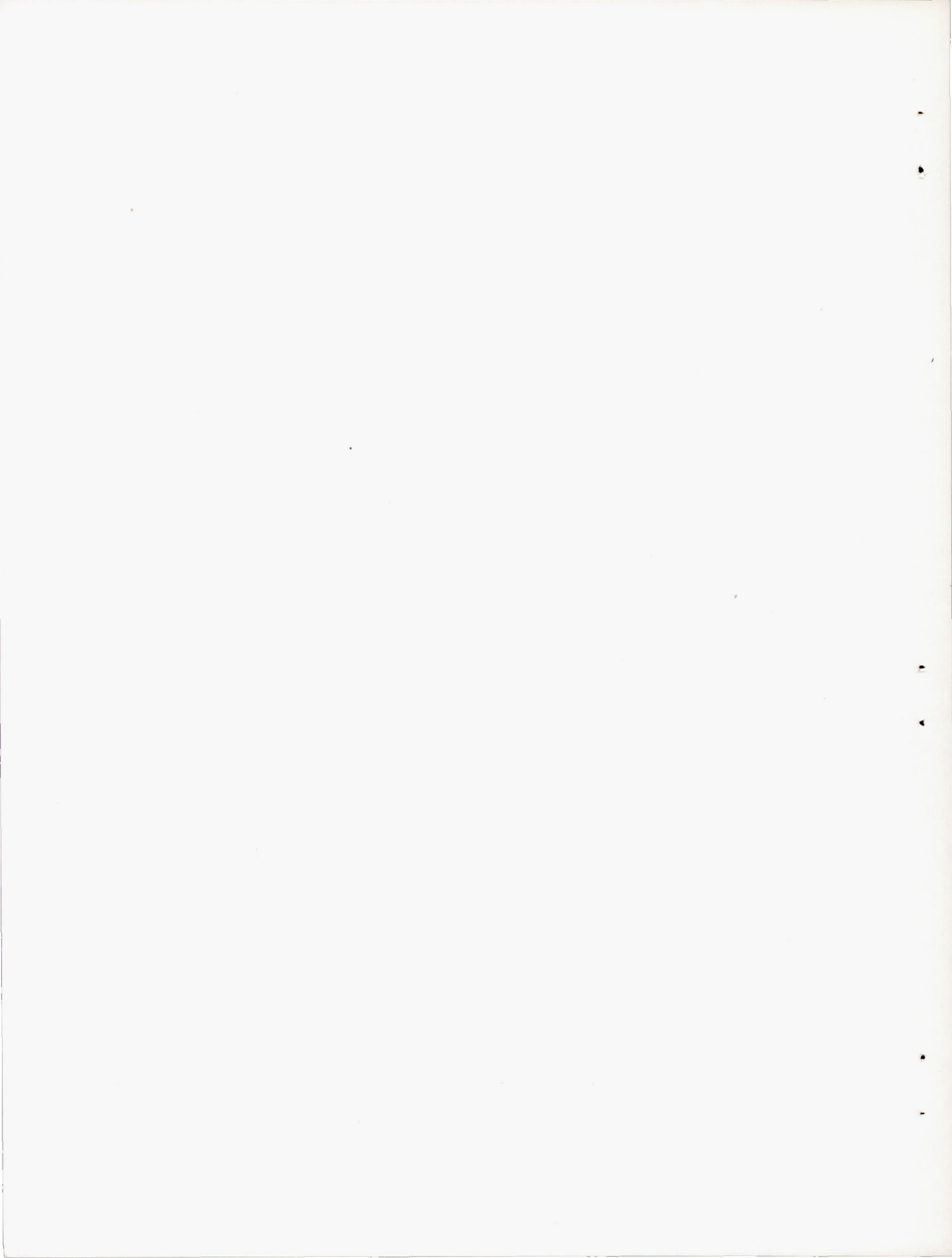
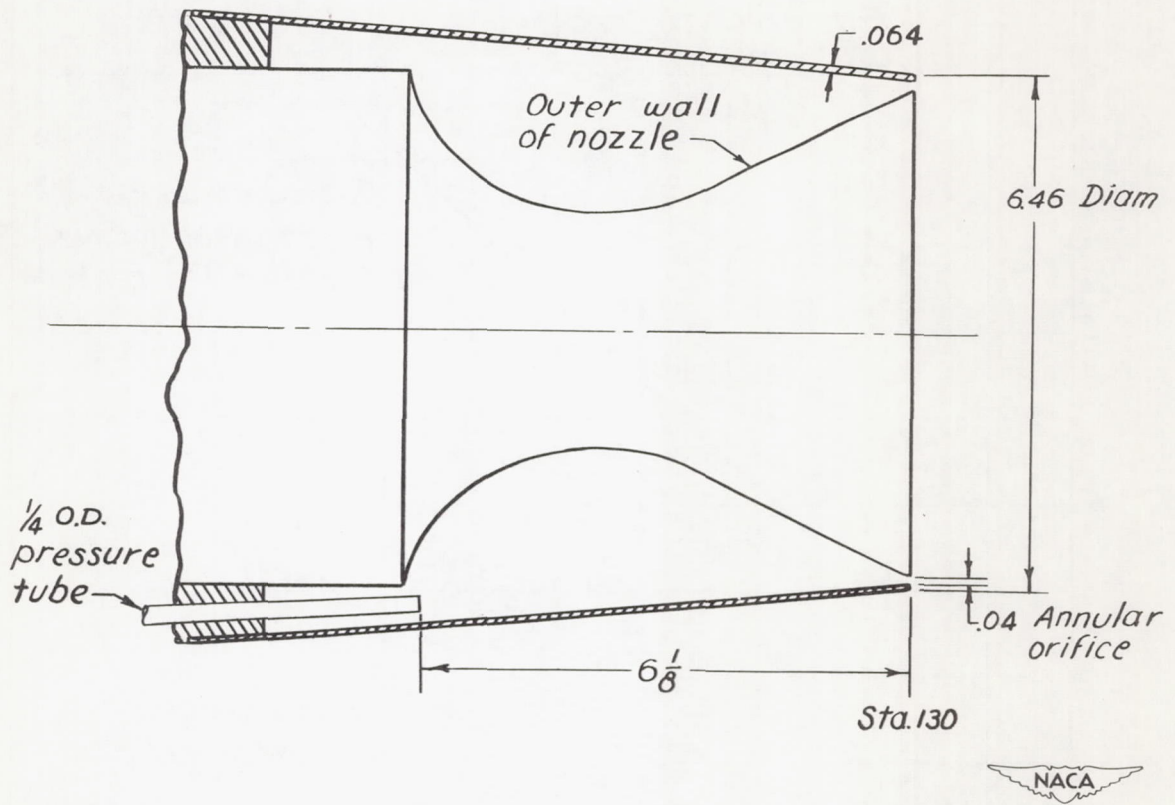

Figure 2.- Test configuration.





Dimensions are in inches

Figure 3.- Base pressure tube installation.

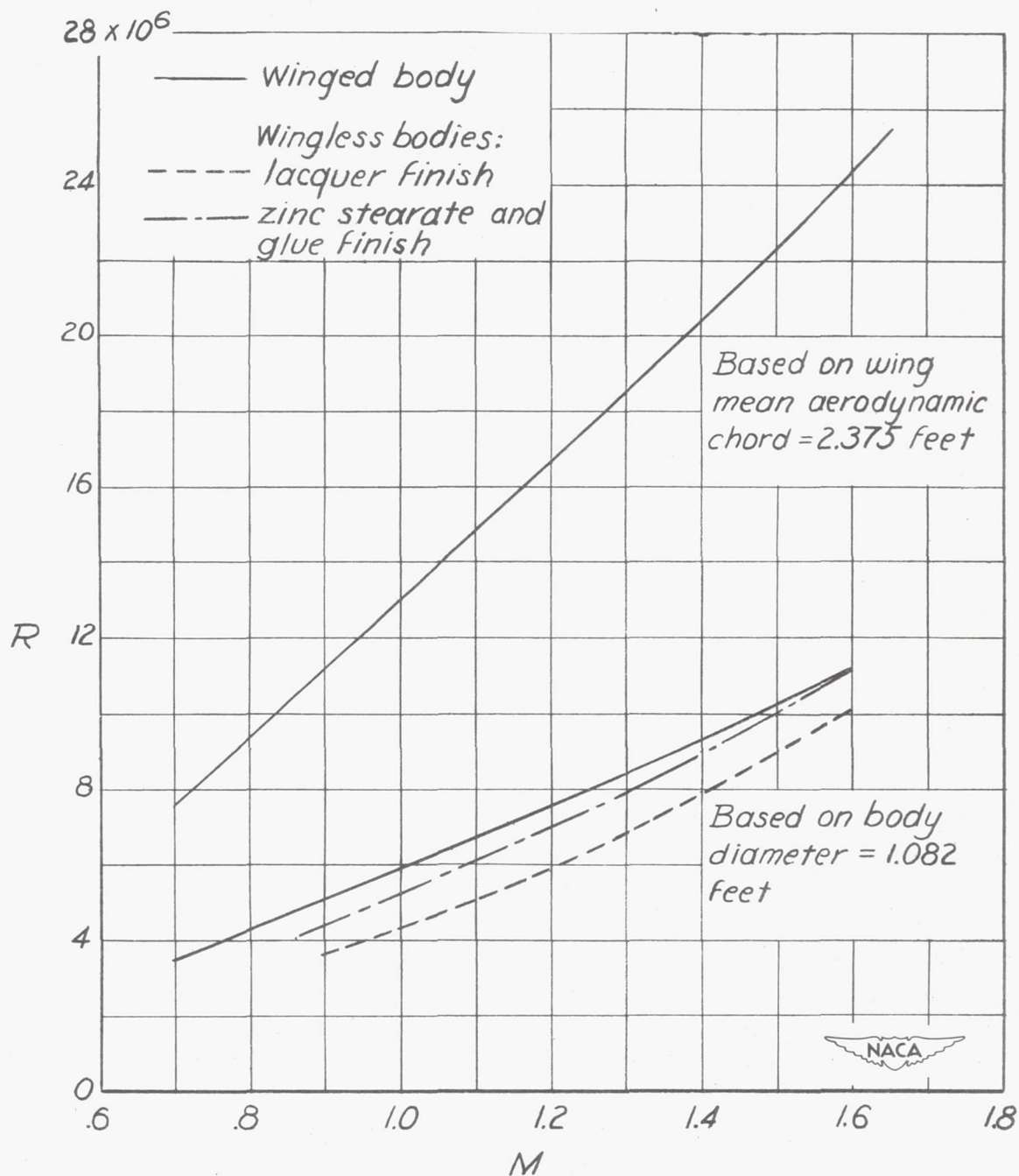
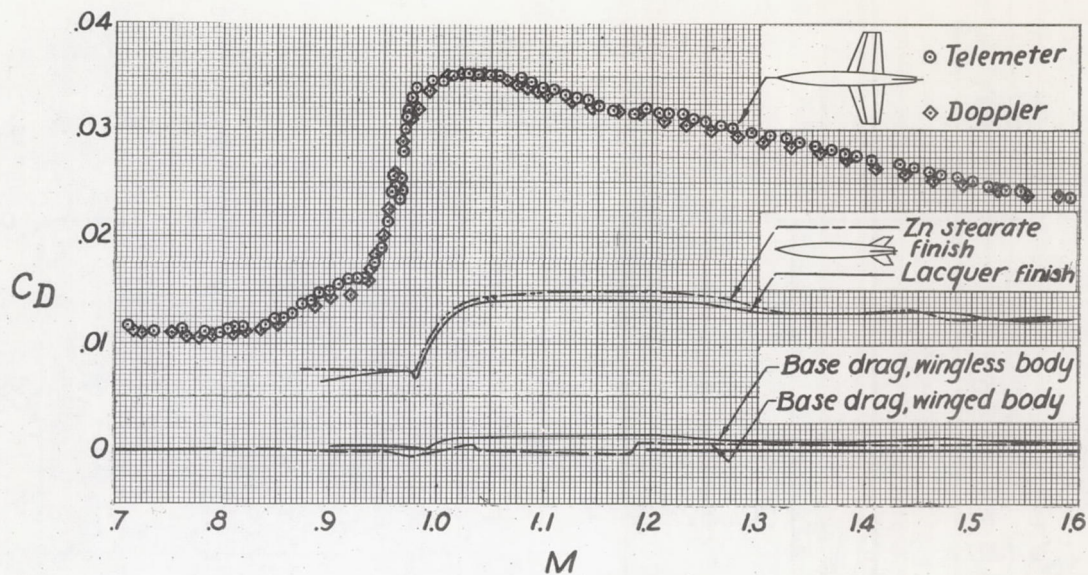
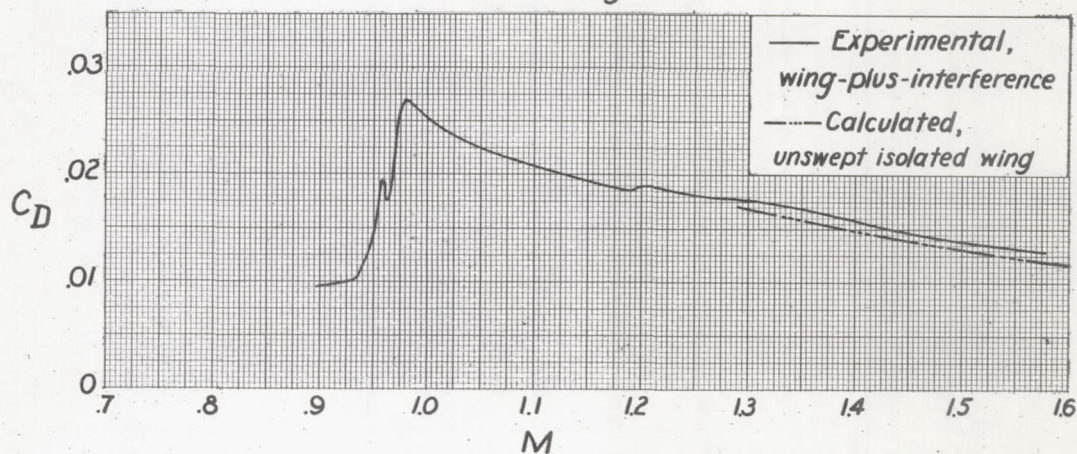

Figure 4.- Variation of Reynolds number with Mach number.



(a) Basic drag data.



(b) Wing-plus-interference drag.

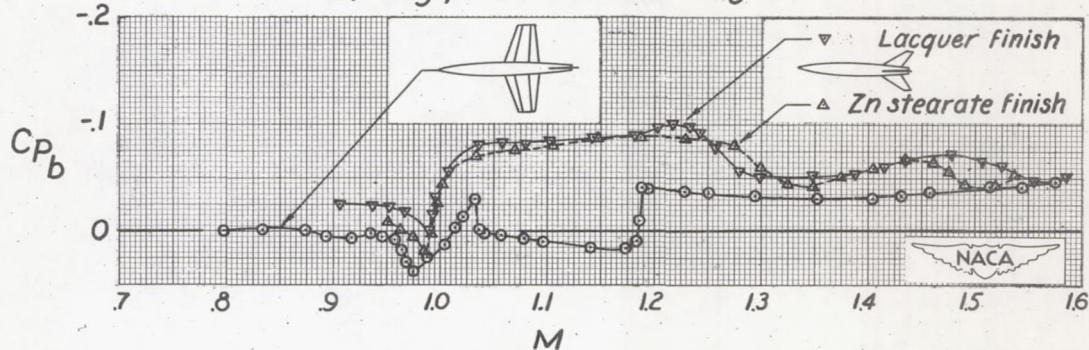

(c) Base pressure coefficient.

Figure 5.- Test results. Drag coefficients are based on total wing area.

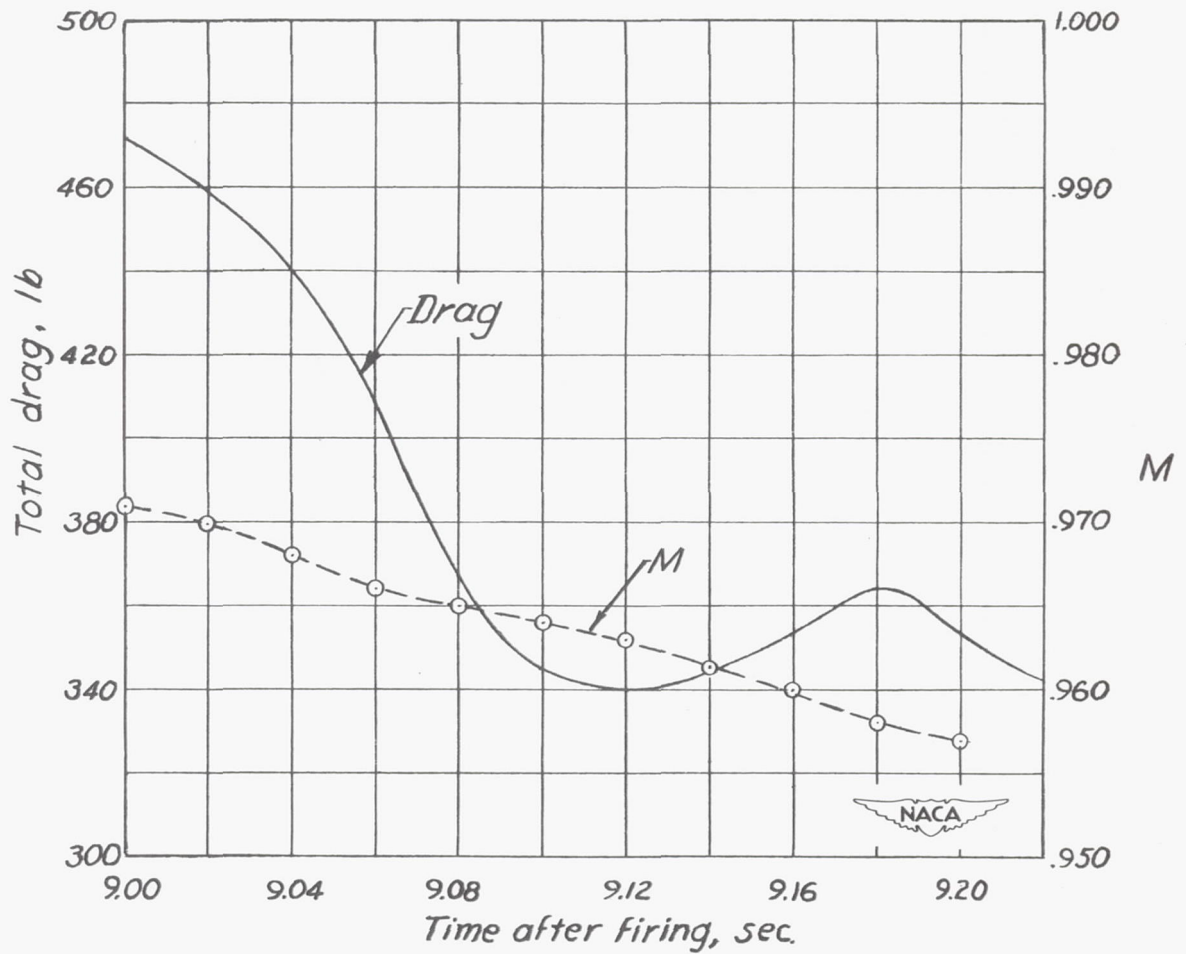

Figure 6.- Characteristics of the drag variation in pounds over the Mach number range 0.96 to 0.97.