

RESEARCH MEMORANDUM

INSTRUMENTATION FOR RECORDING TRANSIENT PERFORMANCE OF
GAS-TURBINE ENGINES AND CONTROL SYSTEMS

By Gene J. Delio and Glennon V. Schwent

Lewis Flight Propulsion Laboratory
Cleveland, Ohio

NATIONAL ADVISORY COMMITTEE
FOR AERONAUTICS

June 27, 1951

NATIONAL ADVISORY COMMITTEE FOR AERONAUTICS
RESEARCH MEMORANDUMINSTRUMENTATION FOR RECORDING TRANSIENT PERFORMANCE OF GAS-
TURBINE ENGINES AND CONTROL SYSTEMS

By Gene J. Delio and Glennon V. Schwent

SUMMARY

Design features are presented for the instrumentation used in a study of the transient performance of gas-turbine engines and control systems. The dynamic characteristics of the instrumentation are discussed and examples are given of typical data on the acceleration of a controlled and an uncontrolled engine.

INTRODUCTION

The measurement and the recording of the transient behavior of gas-turbine engines have become increasingly important in many fields of research. Accurate measurement of engine transient performance is especially important in the field of automatic-controls research in order to provide the knowledge of engine dynamic characteristics necessary for control synthesis. Accurate measurements are also needed in the study of control-system behavior and in the determination of such engine transient limitations as compressor stall and burner blow-out. The engine transients encountered in this work can be accurately recorded only with instruments possessing good dynamic response. The technique of recording engine transient performance with a photopanel and a motion-picture camera is inadequate because of the poor response characteristics of the instruments and because considerable labor is required to transcribe the data from the film into the usable form. The data recorded on film are, furthermore, not immediately available for study, a disadvantage that is important in large test facilities, such as an altitude wind tunnel. Special instrumentation and recording methods have accordingly been developed at the NACA Lewis laboratory as a necessary part of control-systems research.

The problem of recording engine transients has several aspects: First, a recording system is needed that is capable of inking wave forms of transients directly on a moving paper chart and that possesses linear phase shift together with flat frequency response; second,

sensing elements must be designed that can convert all engine variables into electrical signals and that possess good dynamic response; and third, a recording technique must be developed that permits the use of signal amplification about any desired operating point. In engine-controls study, such rapidly changing quantities as fuel-valve position, exhaust-nozzle area, compressor-discharge pressure, turbine-outlet temperature, fuel flow, and engine thrust must be simultaneously recorded, and the record should be immediately available for inspection. A discussion of the problems encountered in recording gas-turbine engine and control transients is presented herein as well as a description of the equipment used in this field of research at the Lewis laboratory. The discussion is presented in four parts: recording and amplifying equipment, sensing-element design, recording technique, and illustrative data.

ESSENTIAL FEATURES OF AMPLIFIERS AND RECORDERS

In the complete recording system, the amplifier, the recorder, and the sensor must be so selected that the system produces an accurate record. The amplifier and the recorder units are common to the recording of all engine parameters; therefore their input impedance, frequency response, and sensitivity must be determined before the sensing elements can be designed.

The amplifier-recorder combinations are commercially available equipment possessing essentially flat frequency response up to 100 cycles per second. Each recorder has an associated amplifier that is frequency-compensated to reproduce accurately both transient and steady-state signals. The frequency range is sufficient for analyses of current gas-turbine engine transients. One of the multichannel installations used at the Lewis laboratory altitude wind tunnel is shown in figure 1.

Amplifiers

Two basic types of amplifier are used to drive the recorders, a direct-coupled amplifier and a strain amplifier. The direct-coupled amplifier produces output power to drive the recorders, and the output power is proportional to input voltages representing either static or dynamic conditions. The strain amplifier produces power proportional to a resistance bridge unbalance (micro-ohm/ohm) and is applicable for use with any resistance sensitive pickup. Thus the strain amplifier can be used to record pressures, forces,

and so forth, which are either static or dynamic, provided the equipment is calibrated in terms of the particular pickup used.

The input to the strain amplifier consists of bonded strain gages applied in a Wheatstone bridge circuit in which the bridge is balanced when the strain gages are unstrained. The strain amplifier measures the unbalance of a bridge having four active strain gages. At maximum sensitivity, the strain amplifier produces one-millimeter pen deflection at the recorder for a strain of $2\frac{1}{2}$ micro-inches per inch strain at the bridge.

The input to the direct-coupled amplifier consists of voltages produced by thermocouples, direct-current tachometers, potentiometers, and so forth. At maximum sensitivity, the direct-coupled amplifier produces one-millimeter pen deflection for every millivolt input.

The requirements of recording technique, described later, necessitate the balancing of the inputs to both amplifiers about any operating point; that is, the signal level at the beginning of each transient recording must be zero. Incorporated in the strain amplifier are resistance and phase balancing controls. In the direct-coupled amplifiers, however, amplification of small voltage changes about large input voltages is necessary; therefore external balancing circuits are used to reduce the input level. The measured over-all drift of both amplifier-recorder combinations is less than 1 millimeter pen deflection per hour.

The high-gain amplifiers used in the recording of engine transients require a constant voltage power supply. Although the power-supply regulators in the amplifiers compensate for long-period drifts in the power supply lines, they do not effectively block the high-frequency transients introduced by the switching of electrical loads. In order to block the high-frequency power line transients, a motor-generator set with a large rotating mass is used as a low-pass filter. This combination of the motor-generator set and the regulators in the amplifiers insures a constant voltage power supply.

Recorders

The recorders incorporate electrodynamic direct-inking pens capable of inking transients on a moving paper chart. The moving-coil pen, energized by a frequency compensated amplifier, writes with good fidelity from direct current up to 100 cycles per second. The pen unit is compact enough to permit placing several units side by side so

that multichannel recording is possible. This arrangement permits study of the transients at the time of occurrence, comparison of several engine variables recorded on a common time base, reproducibility of records, and variation of chart speeds.

Difficulties encountered in reproducing engine operating conditions on succeeding days make imperative the immediate inspection of a recording so that a repeat test may be run immediately if the recording equipment is improperly adjusted. Also, trial tests are necessary to determine if the balancing and sensitivity adjustments give large enough pen deflections without exceeding scale limits. This last need for direct inking is particularly important because the sensitivities and balance must be readjusted for nearly every new test condition. Not only is the facility operating time thus minimized, but also, in controls development, the results of a previous test can be immediately analyzed, and any necessary changes in control design may be incorporated prior to the next test.

Some engine variables are dependent on the instantaneous values of other variables; for example, compressor-discharge total pressure depends on the instantaneous values of fuel flow, speed, ram pressure, and exhaust-nozzle area. Also, some variables in a controlled engine depend on the time history of other variables; for example, engine speed depends on the time history of fuel flow, ram pressure, and altitude. The multichannel recorder used can make simultaneous records of 6 variables with a common time base on one chart; because simultaneous recording of up to 18 variables is required, three 6-channel recorders are used. Time-marker pens are installed in each multiple-channel unit and are energized from an identical source to correlate the three recorders and provide a common time base for all channels.

DESIGN FEATURES OF SENSING ELEMENTS

The dynamic characteristics of a complete sensing system depend upon the individual characteristics of the sensing element, amplifier, and recorder. The sensing element is defined as the complete transducer, which converts sampled energy at the engine (for example, pressure) to electrical energy at the input of the amplifier located in the control room. The sensing element must be designed with consideration of the characteristics of the recorder and the amplifier if an accurate record of the transient is to be achieved. The requirements of a sensing element are that the output (voltage) be linear with respect to the input (temperature, pressure, position, or velocity), that it have good dynamic response, and that its power sensitivity be great enough to give full-scale deflection on the recorder when the transient is imposed.

Pressure-Sensing Element

Many types of pressure sensor are commercially available. The type selected incorporates a bellows mechanically connected to a bonded strain-gage bridge having four active strain gages. This choice was made to utilize the high gain of the strain amplifier.

A high sensitivity is required of pressure-sensing elements because of the wide range of pressures that are encountered. For example, a pressure sensor giving full-scale signal at sea level will give only approximately 10 percent of full-scale signal at an altitude of 50,000 feet. Moreover, it is usually desired to make a full-scale recording of a transient that varies over a small percentage of the static-pressure differential on the sensor. Consequently, in order to record engine transients at altitude, it is frequently necessary to use much less than 1 percent of the rated range of the sensor.

The very high sensitivity required of pressure sensors introduces two problems: The mechanical vibration from the engine is transmitted through the sensor and creates a noise signal in the sensor output that makes the transient signal less readable; and, furthermore, the sensitivity is high enough that the sensor will detect distortion resulting from the pneumatic transient response of the sensor with its connecting tubing.

Vibration isolation. - The pressure sensor must be mounted close to the engine to avoid distortion resulting from long pressure tubes. If, however, the sensor is mounted near the engine, the mechanical vibration from the engine can be transmitted through the sensor mount to the sensor and then to the sensor output, where it appears as electrical noise. For pressure changes of 1 percent of the sensor range, engine operation produces vibration of sufficient magnitude to lower the signal to a noise ratio below 1. Because electrical filtering of the sensor output cannot filter the low vibrational frequencies without distorting the signal, the only alternative is to provide vibration isolation of the pressure sensors.

For maximum vibration isolation, the sensor mount must possess the lowest possible natural frequency. The natural frequency varies inversely as the square root of the static deflection. This low natural frequency, or large static deflection, is obtained by the type of mounting illustrated in figure 2. The pressure sensors are suspended by springs inside holes cut in a large steel plate. The steel plate, 3/8 inch thick, is suspended by elastic shock cords that are fastened to a frame mounted on the engine test bed. The plate is oriented to give the least vibrational amplitude parallel to its

surface. The pressure sensors are so oriented that the most sensitive plane of the sensor is parallel to the plane of the plate. This installation has sufficiently low transmissibility that the vibrational effects introduced by normal engine operation become apparent only at the highest gain setting of the recording system.

Pneumatic transient characteristics. - The second problem occurring in the design of a pressure-sensing element is the necessity for avoiding distortion due to the pneumatic characteristics. The distortion is minimized by choosing a pressure-sensor volume that is as small as possible, and tube dimensions that produce the highest undamped natural frequency and desired damping ratio. The principle of this design is given in reference 1. According to reference 1, the transfer function of the tube and reservoir volume (assuming a lumped-constant system) is shown to be a function of system dimensions and gas conditions. The transfer function is defined as the ratio of the Laplace transform of the pressure response in the pressure reservoir to the Laplace transform of the pressure disturbance at the mouth of the tube. The transfer function is

$$\frac{P_c(s)}{P_d(s)} = \frac{1}{\frac{s^2}{\omega_0^2} + 2 \frac{\zeta}{\omega_0} s + 1} \quad (1)$$

where the undamped natural frequency is

$$\omega_0 = \sqrt{\frac{\pi r^2 \gamma g R T_0}{LV}} \quad (2)$$

and the damping ratio is

$$\zeta = \frac{4r}{P_0 r^3} \sqrt{\frac{VLgRT_0}{\pi \gamma}} \quad (3)$$

The symbols are defined in the appendix.

2139

Because the problems of vibration consideration and equipment installation require the use of tubing 5 to 14 feet in length, the lumped-constant assumption of reference 1 is not completely valid. Use is made, however, of the test technique described therein and of equations (2) and (3) herein to arrive, by experiment, at the proper tube dimensions. Equations (2) and (3) describe the variation of the coefficients of the transfer function with operating pressure and temperature.

The complete pressure-sensing system (length of tubing, pressure sensor, amplifier, and recorder) was bench-tested by introducing a square-wave pressure disturbance at the mouth of the tube. The response was noted on the recorder. Different tube radii were used until the desired response was achieved. The effect of varying tube radii is shown in figure 3.

The tube radius is varied to achieve a damping ratio slightly less than critical (a condition approached most closely by fig. 3(b)) at bench atmospheric conditions. The pressures and the temperatures in the engine differ from bench conditions and vary with engine speed and altitude. The tube radius arrived at by bench tests is therefore changed according to equation (3) to yield the bench damping ratio at the operating conditions of minimum temperature and maximum pressure anticipated during engine operation. As seen from equation (3), the design conditions corresponding to minimum temperature and maximum pressure insure that the damping ratio never drop below the design value.

At sea-level conditions, the slowest of the pressure sensors has a flat response from 0 to 8 cycles per second. As the pressure level drops, the damping ratio increases and the response rate of the instrument decreases. As the altitude increases and the pressure level drops, however, the engine response rate decreases accordingly. The relative time responses of the instrument and the engine thus remain approximately the same over a range of altitude.

Sensitivity. - Because the range of the pressure sensors used depends on the parameter being measured, the over-all sensitivities of the various pressure-sensing systems differ (fig. 4). The maximum sensitivity of the strain amplifier-recorder combination using four active gages is 0.4-millimeter pen deflection per microinch per inch of strain. The maximum over-all sensitivity of the least sensitive pressure-sensing system is 7 millimeters pen deflection per inch of mercury (fig. 4(a)). The maximum sensitivity achieved is 1 millimeter pen deflection per 0.01 inch of mercury.

Speed-Sensing Element

Sensitivity. - A small direct-current motor, coupled directly to the compressor shaft, is used as a generator to convert speed into an electrical signal. The two-pole direct-current motor has a permanent magnet field and is rated at a speed of 11,000 rpm at 12 volts. As a generator, the output is approximately 1 millivolt per rpm. The output was found to be linear when coupled to a direct-coupled amplifier having an input impedance of 7 megohms. The over-all sensitivity of the speed-sensing system is 1-millimeter pen displacement per rpm (fig. 4(b)).

Filter. - The use of a direct-current generator requires a low-pass filter to remove the commutator ripple. In the filter design, a compromise is necessary because the filter affects both the noise (commutator ripple) and the engine-speed signal. A filter having an undamped natural frequency of 8 cycles per second and a damping ratio of 0.6 allows a sufficiently wide pass band for the signal and provides the necessary filtering of the commutator ripple. The response of the speed-sensing system (d-c. amplifier, recorder, and filter) is illustrated in figure 5. The disturbances are steps in voltages corresponding to speed changes of 100 rpm.

Temperature-Sensing Element

The successful application of thermocouples for sensing transient temperatures in a gas stream requires the solution of two problems: The first problem is caused by insufficient sensitivity; the second, and major problem, concerns the dynamic characteristics of the thermocouple.

Sensitivity. - Two techniques are used to increase the sensitivity. A choice of thermocouple metals is first made to obtain high thermoelectric power (mv/°F) and the sensitivity is then further increased by the series connection of several thermocouples. The thermocouple output is directly coupled to a direct-coupled amplifier having a gain of 1000.

The sensitivity of a chromel-constantan thermocouple, at the temperature of the exhaust gas in an engine, is approximately 4.4 millivolts per 100° F. Series connection of several thermocouples multiplies the sensitivity and has the added advantage of averaging the temperature sensed at each thermocouple. This averaging is necessary because random fluctuations of the order of 100° F have been noted at one thermocouple when measuring turbine-discharge temperature.

2139

As an example, five thermocouples are circumferentially arranged and series-connected to sense average turbine-discharge temperature. The sensitivity, or thermoelectric power, of this combination is 22 millivolts per 100° F. The maximum over-all sensitivity of the temperature-sensing system then is 0.22-millimeter pen deflection per °F (fig. 4(c)).

Transient behavior. - The time lag of a thermocouple varies with mass flow, thermocouple mass, and geometric configuration. An annealed, butt-weld, loop-type configuration is used. The smallest gage wire that has an acceptable life expectancy for engine research purposes was found to be No. 24 gage. This thermocouple design produced a measured response time of less than 1/4 second at maximum engine mass flow at sea level.

Flow-Rate-Sensing Element

Fuel flow is measured by using a differential pressure sensor to record the pressure drop across an orifice. At high altitudes, the maximum engine fuel flow is only 10 percent of the sea-level maximum. Because the pressure drop varies as the square of the flow, a fixed orifice produces a pressure drop at altitude that is only 1 percent of the sea-level pressure drop. A variable-area orifice is therefore used to utilize the full range of the differential pressure sensor at all altitudes.

Noise. - Because the pressure sensor senses the instantaneous differences of two large pressures, extreme care is necessary to reduce the noise introduced by the turbulence and the vibration of connecting tubing. Pipe taps are located in enlarged sections on both sides of the orifice, as shown in the following sketch:

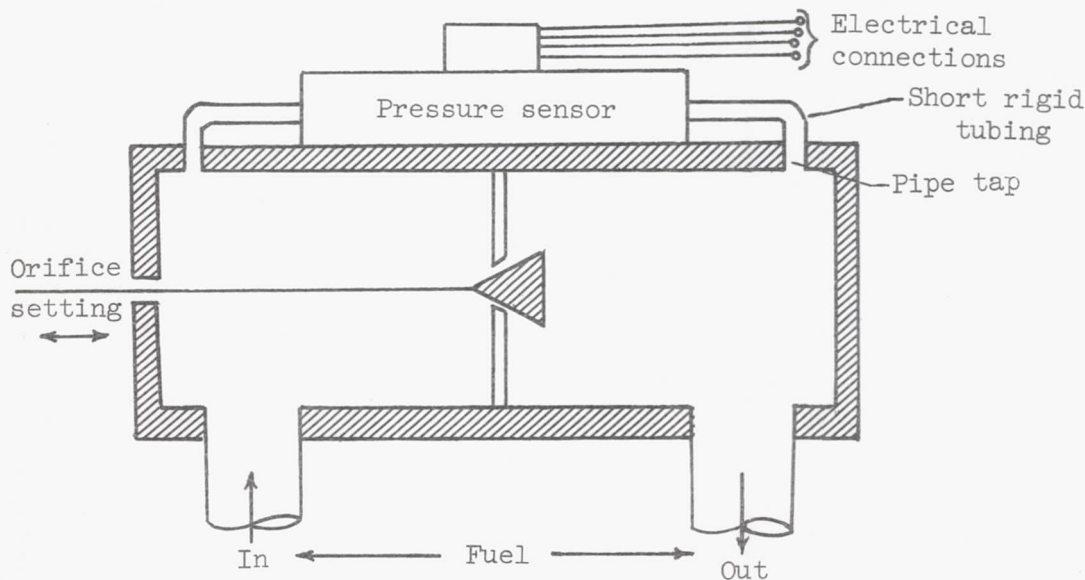

The taps are located in regions of low turbulence and measure only the pressure loss due to throttling. The pressure sensor is firmly mounted on the variable-orifice housing and is connected to the housing with short, rigid tubing. When the noise level is reduced to a practical minimum, the signal-to-noise ratio is increased by varying the area to operate the pressure sensor near its maximum rating.

Dynamics and sensitivity. - The dynamic behavior of the fuel-flow sensing system does not readily lend itself to analysis. An indication of the dynamic behavior can be obtained by noting the correlation between traces of fuel-valve position and fuel flow in figure 6. This figure is a record of six engine variables during unstable control operation. For this case, the control manipulates the independent variable (fuel flow) by positioning the fuel valve as a function of speed error.

The over-all sensitivity of the fuel-flow-sensing system depends on the area of the orifice. For maximum sensitivity, the orifice is adjusted to operate the pressure sensor near its maximum rating for the largest flow anticipated during the engine transient under investigation. Although the differential pressure varies as the square of the flow, linearity may be assumed for changes of flow that are small relative to the steady-state flow. For large flow changes, the nonlinearity of the instrument must be considered.

Thrust-Sensing Element

Installation. - Transient thrust is indicated by measuring the change in stress in the engine mount. Strain gages were bonded to the two cantilever engine supports, as shown in figure 7. The third support at the front of the engine has swivel connections so that all horizontal components of force are transmitted to the two cantilever mounts. The four strain gages (two on each cantilever mount) were connected in a bridge in a sequence that canceled stress signals due to engine yaw or roll. This bridge arrangement is also shown in figure 7.

Sensitivity and dynamic response. - The sensitivity of the thrust sensor is proportional to the strain in the cantilever mounts produced by the thrust. High sensitivity can be achieved by using highly stressed mounts. The mounts used were designed so that a thrust of 5000 pounds produced a stress in the cantilever supports of 15,000 pounds per square inch. This force caused a strain at the strain-gage locations of 500 microinches per inch. At maximum sensitivity, the strain amplifier produces a pen deflection of 1 millimeter per

$2\frac{1}{2}$ microinches per inch strain. Thus the maximum sensitivity of the complete thrust-sensing element is 25 pounds of thrust per millimeter of pen deflection.

The minimum amplitude of signals that can be recorded is limited by the amplitude and the frequency of vibration of the engine mount. This frequency is too low to be filtered without distorting the thrust signal. At high engine speeds, the amplitude of vibration was found to be so high that the readability of the record for small thrust increments was decreased. The sensitivity of the thrust-recording equipment varies with the stress of the engine mount, and the frequency of engine-mount vibration varies inversely with the stress of the engine mount; therefore, a compromise mount stress of 15,000 pounds per square inch was necessary.

Position-Sensing Elements

All mechanical motions, such as those associated with fuel-valve position, exhaust-nozzle area, and throttle-lever positions, are converted to electrical signals with mechanically coupled potentiometers. The over-all sensitivity of the position sensor is determined by the arbitrary magnitude of the direct-current voltage applied across the potentiometer, and the dynamic response is limited by the response of the amplifier-recorder combination (fig. 4(d)).

RECORDING TECHNIQUE

In the design of the recording system, the prime objectives are: sufficient sensitivity, linearity, good dynamic response, and very slow drifts. In order to accomplish these objectives, the steady-state calibration is sacrificed. Thus, the recording system is used to obtain only the correct form of the transient. The absolute values of the variables are obtained from steady-state instrumentation. The combination of this recording system with steady-state instrumentation necessitates a technique of sensitivity and calibration adjustments for the instrumentation used to record engine transients during the progress of engine testing.

Sensitivity Adjustment

The greatest accuracy in reading the records is obtained when the full chart width is used for each transient recording. In order to utilize the full chart width, the engine is operated in steady

state at one extreme condition of the expected transient, and the signal input is balanced to position the recording pen at one edge of the chart. Trial transients are run and the sensitivity is adjusted until the full width of the chart is traversed during the transient.

The need for trial transients in adjusting the sensitivity is illustrated in figure 8. This figure is a recording of six engine variables obtained during a controlled acceleration. The engine control measures speed and adjusts the fuel-valve position. Inspection of the figure shows an overshoot in fuel-valve position, compressor-discharge total pressure, and turbine-outlet temperature. Proper adjustment of the sensitivity is possible only by use of trial transients.

Calibration

Generally, two different methods of calibration are used, depending upon the type of transient involved. For a transient in which the initial and final steady-state values differ, calibration is obtained by using values from conventional steady-state instrumentation. For a transient in which the initial and final values are essentially the same, a calibration is obtained by noting the steady-state values for two different engine conditions while maintaining the gain settings constant. The channel is then calibrated by use of the sensitivity and the initial steady-state values.

Operating Procedure

The operating procedure used in obtaining the recording shown in figure 8 is as follows: The engine and tunnel conditions were adjusted to the initial condition of the proposed transient, and the recording channels were adjusted to position the recording pens near the edges of their respective charts. A trial run of the proposed transient was made and the sensitivities of the channels were individually adjusted to give the desired deflection. The record obtained with the final adjustment was retained for analysis and is presented as figure 8.

After the engine has been allowed to reach equilibrium at the initial conditions and prior to the proposed transient, data from the steady-state instrumentation are recorded. Immediately following the transient, readings from the steady-state instrumentation are again taken, thereby providing calibration for each channel. The steady-state instruments needed are grouped on a panel and photographed before and after each desired transient.

EXPERIMENTAL DATA

The controlled and uncontrolled engine dynamic behavior may be analyzed with the instrumentation and the recording technique outlined in this report. The study of records of engine transients, such as those shown in figure 8, which was obtained during the controlled acceleration of a turbojet engine, will yield information of the following type: control gain, peak values of various engine parameters, engine acceleration time, degree of control stability, instantaneous relations among various engine parameters, and presence of compressor stall and burner blow-out. Following are some typical results obtained in the recording of turbojet-engine transients under altitude conditions.

Compressor Stall

An analysis of the condition under which compressor stall was encountered in an axial-flow jet engine may be made using the data presented in figure 9. In this case, compressor stall occurred during acceleration. Inspection of figure 9 will show that the fuel valve responded correctly to a change in speed setting introduced into the engine control. The fuel flow, turbine-outlet temperature, and compressor-discharge total pressure increased with the increase in fuel-valve position. The engine began to accelerate to a higher speed and reached a condition where the compressor-discharge total pressure reached the stall pressure for the existing engine speed. Stall occurred where the compressor-discharge total pressure fell quickly, and the engine acceleration was greatly reduced. The turbine-outlet temperature increased rapidly at stall until the over-temperature damaged the thermocouples. As indicated by the traces, the stall indicated by the turbine-outlet temperature was about 1/25 second later than the stall indicated by the compressor-discharge total pressure.

Following the initiation of stall, a condition of surge at a lower compressor-discharge pressure was established. The frequency of pressure fluctuation, 55 cycles per second, is correct, but the amplitude of surge is regarded as incorrect because the surge frequency is above the design frequency range of the pressure-sensing system.

Control Instability and Burner Blow-out

An illustration of the type of record obtained with an unstable control system is given in figure 6. The figure also shows a record of burner blow-out. Shown are six important engine variables together

with an event marker trace that provides an accurate time scale. These records show that the engine control opened the fuel valve gradually until an unstable condition was reached and an oscillation of all variables except nozzle area occurred.

During the last three cycles, a condition of burner blow-out was approached, which is thought to be the cause of the flattening of the wave forms for the fuel-valve position and the compressor-discharge pressure. It is possible that the flame traveled through the turbine into the exhaust nozzle and then back into the combustion chamber after the compressor-discharge pressure had dropped. On the last cycle, the flame front traveled out through the exhaust nozzle, resulting in burner blow-out.

CONCLUDING REMARKS

The type of instrumentation described in this report has made possible accurate determination of engine variables during transient engine operation. It has also given a quantitative evaluation of engine dynamic behavior during acceleration, compressor stall, and burner blow-out. Furthermore, it has proven to be a useful development tool for control designers because the results of each control modification can be immediately observed.

Lewis Flight Propulsion Laboratory,
National Advisory Committee for Aeronautics,
Cleveland, Ohio.

APPENDIX - SYMBOLS

The following symbols are used in this report:

E	volts
g	gravitational constant, ft/sec ²
L	length of tube, ft
N	engine speed, rpm
P	absolute pressure, lb/sq ft
P _c (s)	Laplace transform of pressure change in reservoir
P _d (s)	Laplace transform of pressure disturbance
p	time derivative, d/dt
p ₀	initial steady-state absolute pressure, lb/sq ft
R	gas constant, ft-lb/(lb)(°R)
r	radius of tube, ft
s	complex variable
T ₀	initial steady-state absolute temperature, °R
T ₆	turbine-outlet temperature, °F
V	volume of pressure sensor reservoir, cu ft
x	pen displacement, mm
γ	ratio of specific heats
ε	strain, microin./in.
ζ	damping ratio
θ	fuel valve position, deg

ω_0 undamped natural frequency, radians/sec

REFERENCE

1. Delio, Gene J., Schwent, Glenmon V., and Cesaro, Richard S.:
Transient Behavior of Lumped-Constant Systems for Sensing Gas
Pressures. NACA TN 1988, 1949.

2139

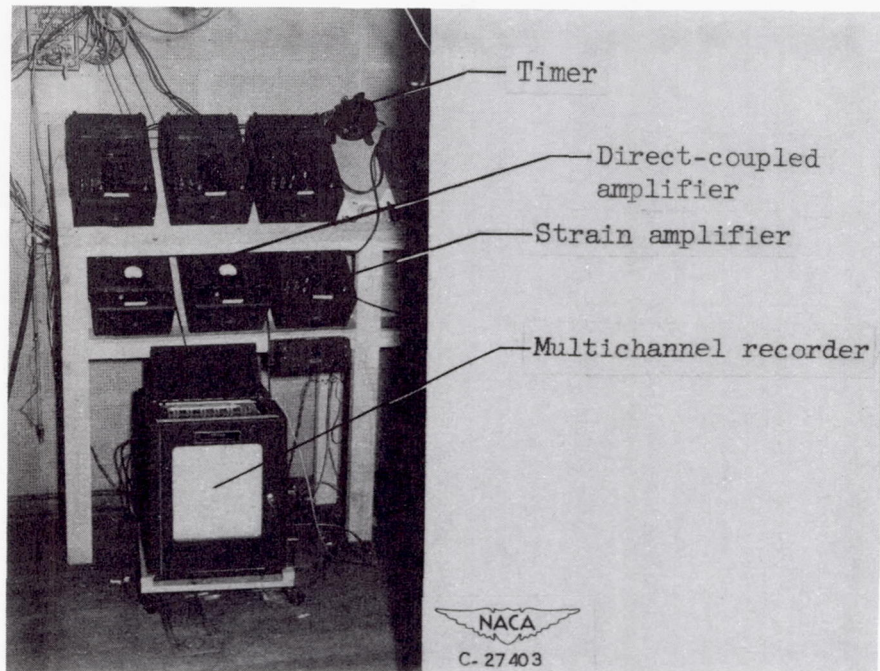
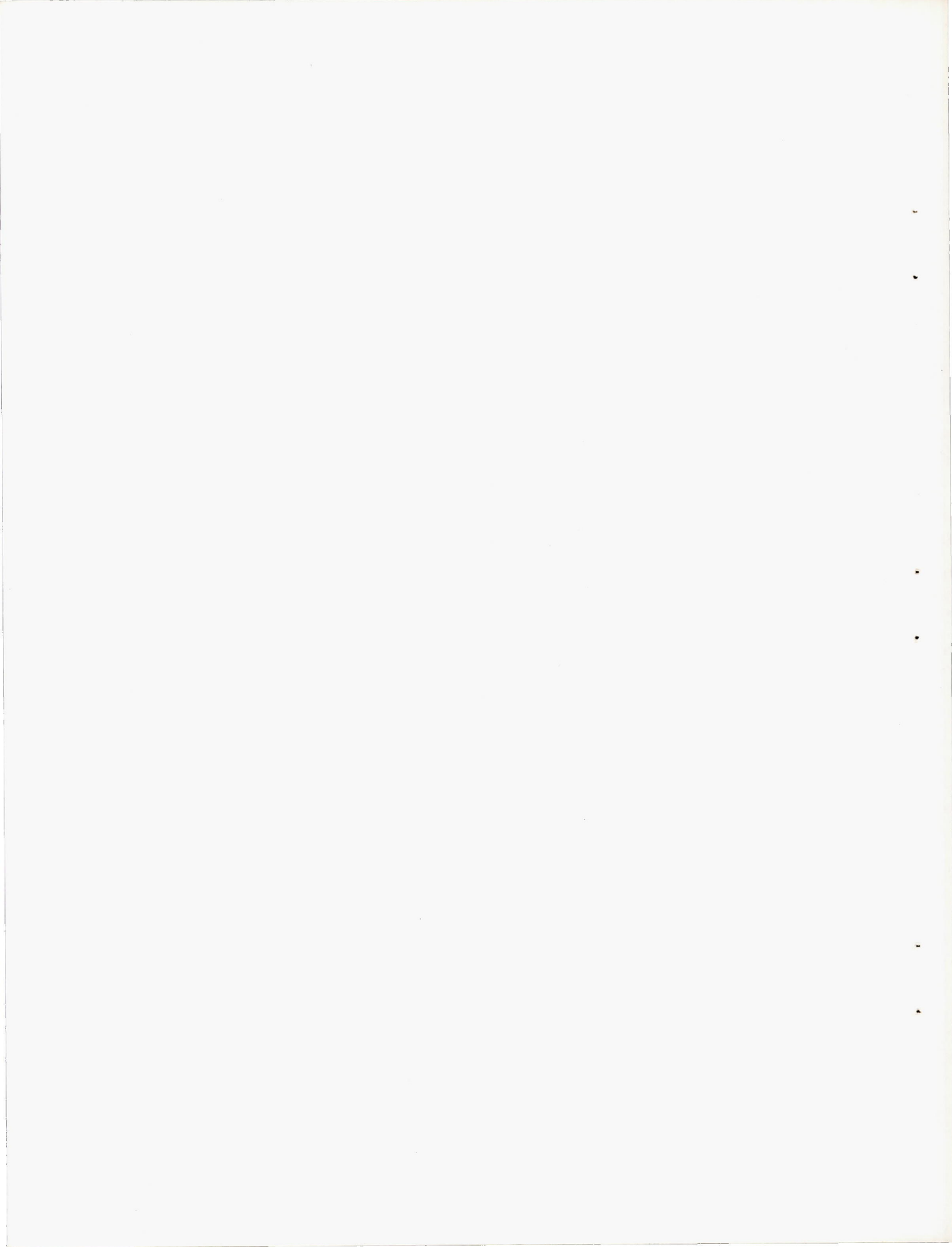

Figure 1. - Recording oscillograph with six amplifiers.



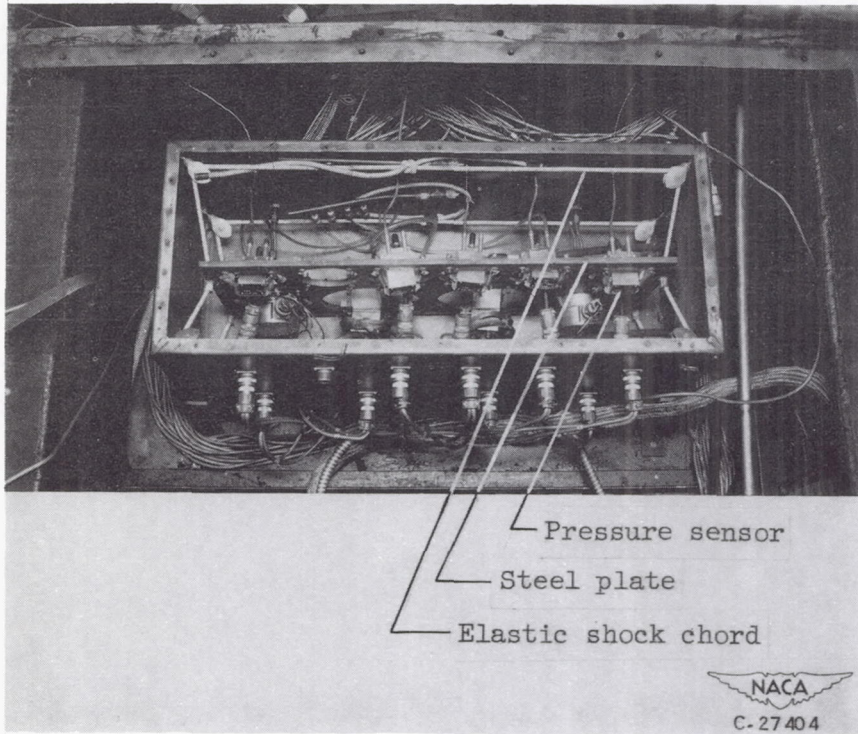
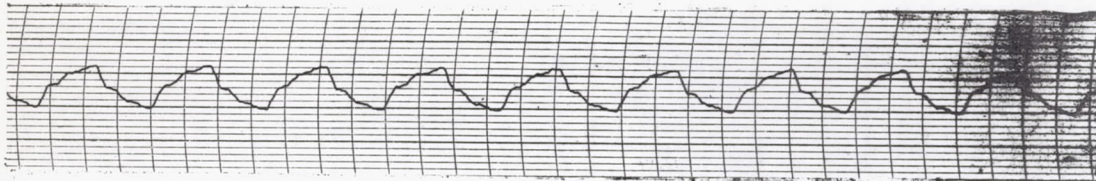
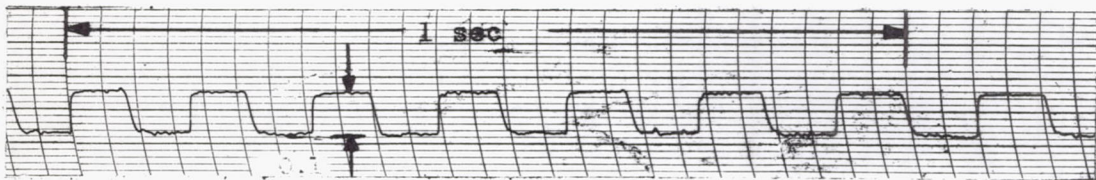

Figure 2. - Mounts to isolate pressure sensors from mechanical vibration.

2139



(a) Pressure sensor, greatly overdamped; tube length, 6 feet; tube radius, 0.024 inch.



0.1 in. Hg

(b) Pressure sensor, correctly damped; tube length, 6 feet; tube radius, 0.031 inch.

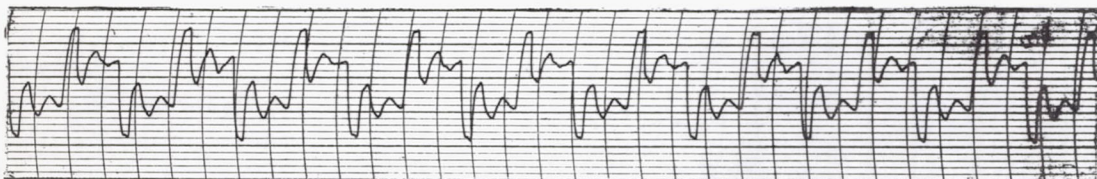

(c) Pressure sensor, underdamped; tube length, 6 feet; tube radius, 0.052 inch.



Figure 3. - Illustrations of effect of varying tube radii on damping ratio of pressure sensor; tube length and reservoir volume constant.

2139

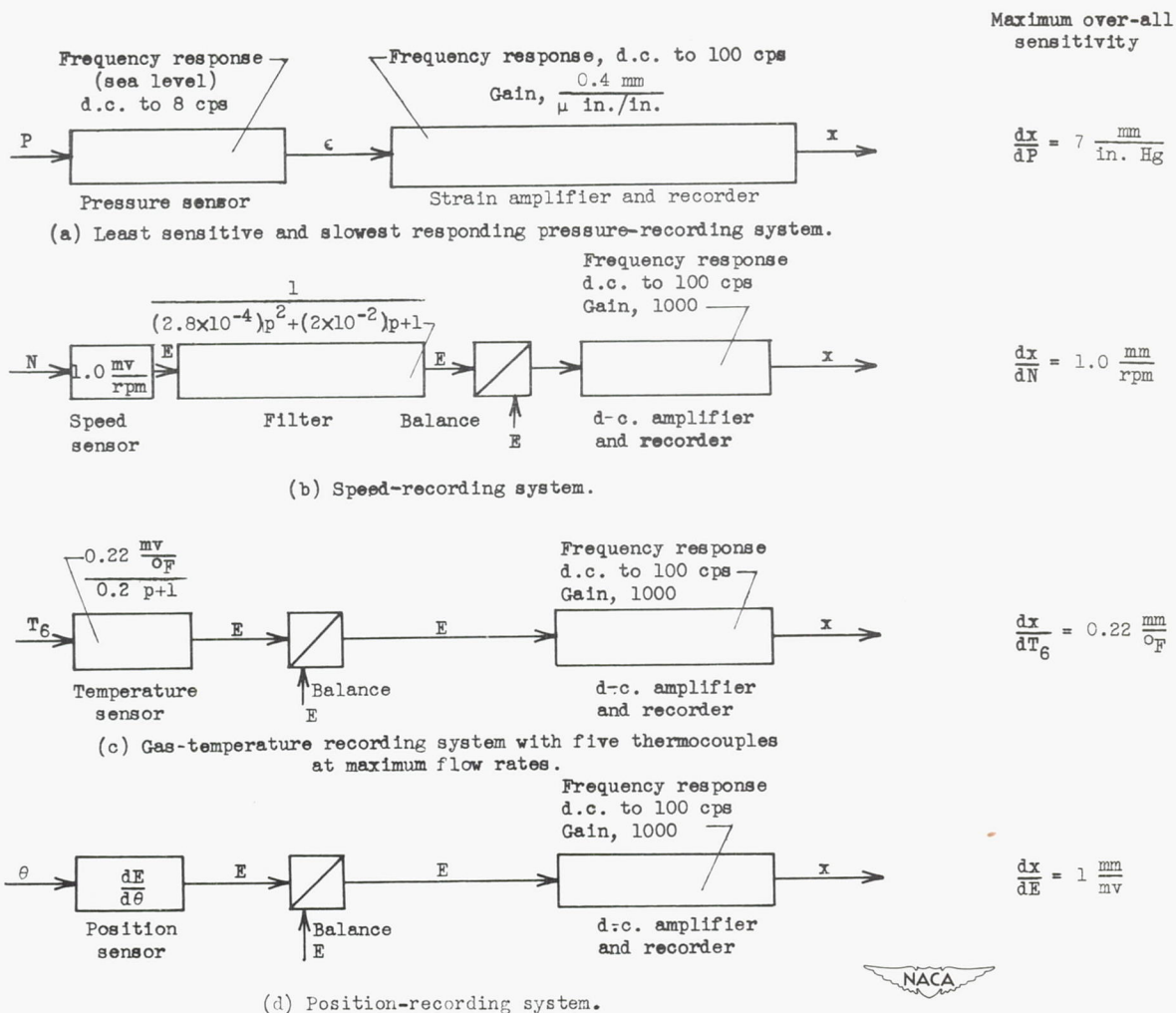

Figure 4. - Block diagrams showing component lags and gains of basic sensing systems.



2139

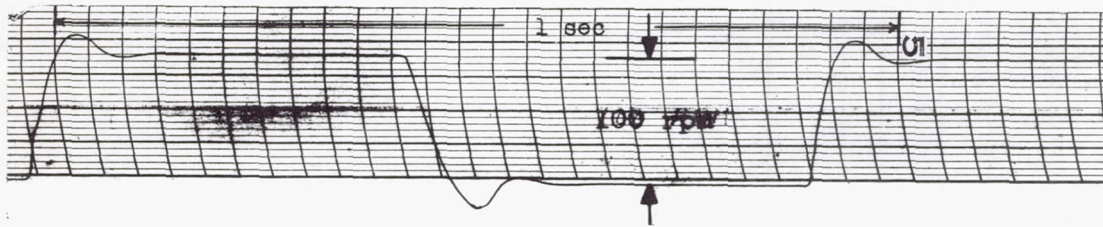

Figure 5. - Response of speed-sensing system to voltage disturbances corresponding to 100 rpm. Damping ratio, 0.6.

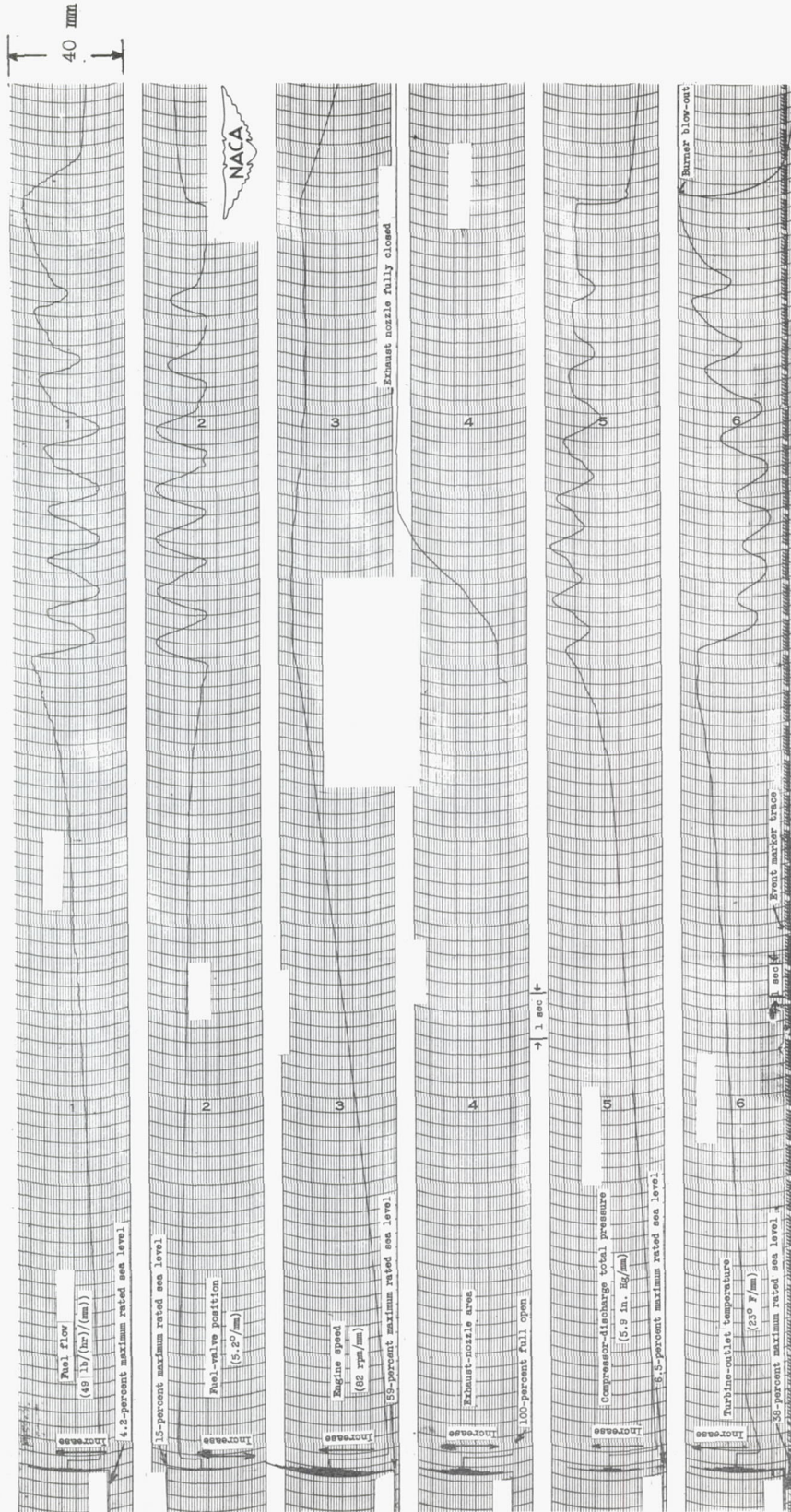

Figure 6. - Time record of variables in turbojet engine during instability resulting from improper control.

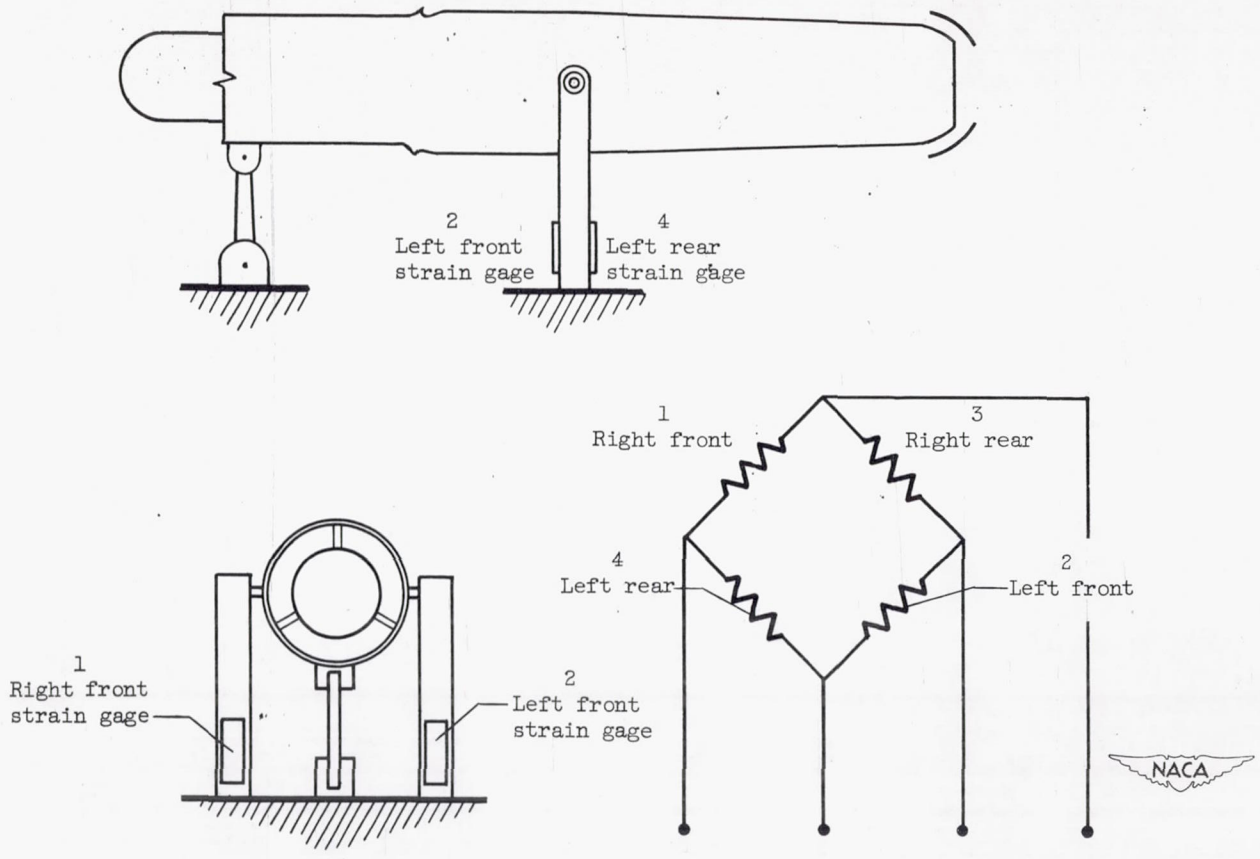

Figure 7. - Sketch showing method of mounting engine and location of strain gages for thrust-change measurements.

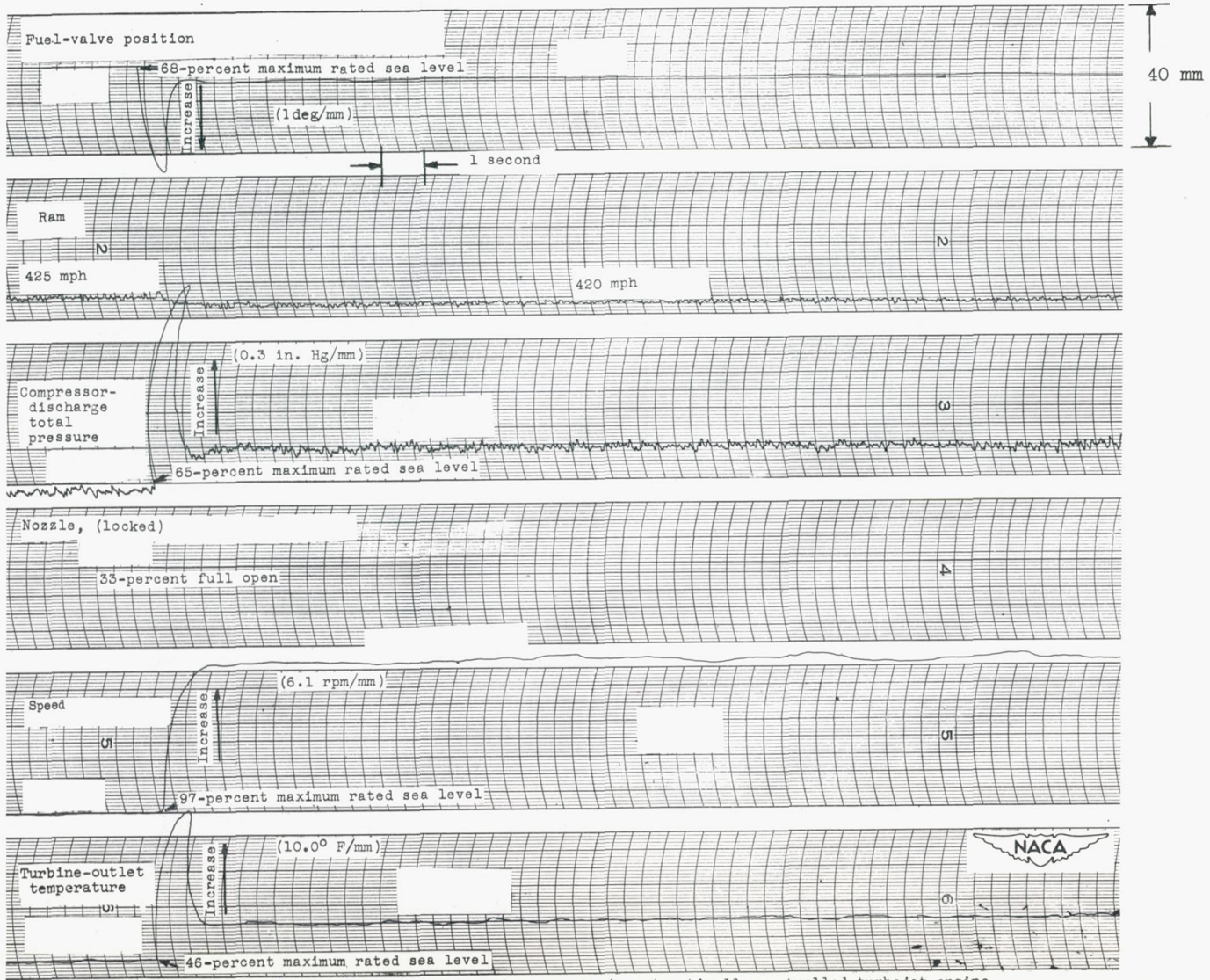

Figure 8. - Sample recording of transient events in automatically controlled turbojet engine.

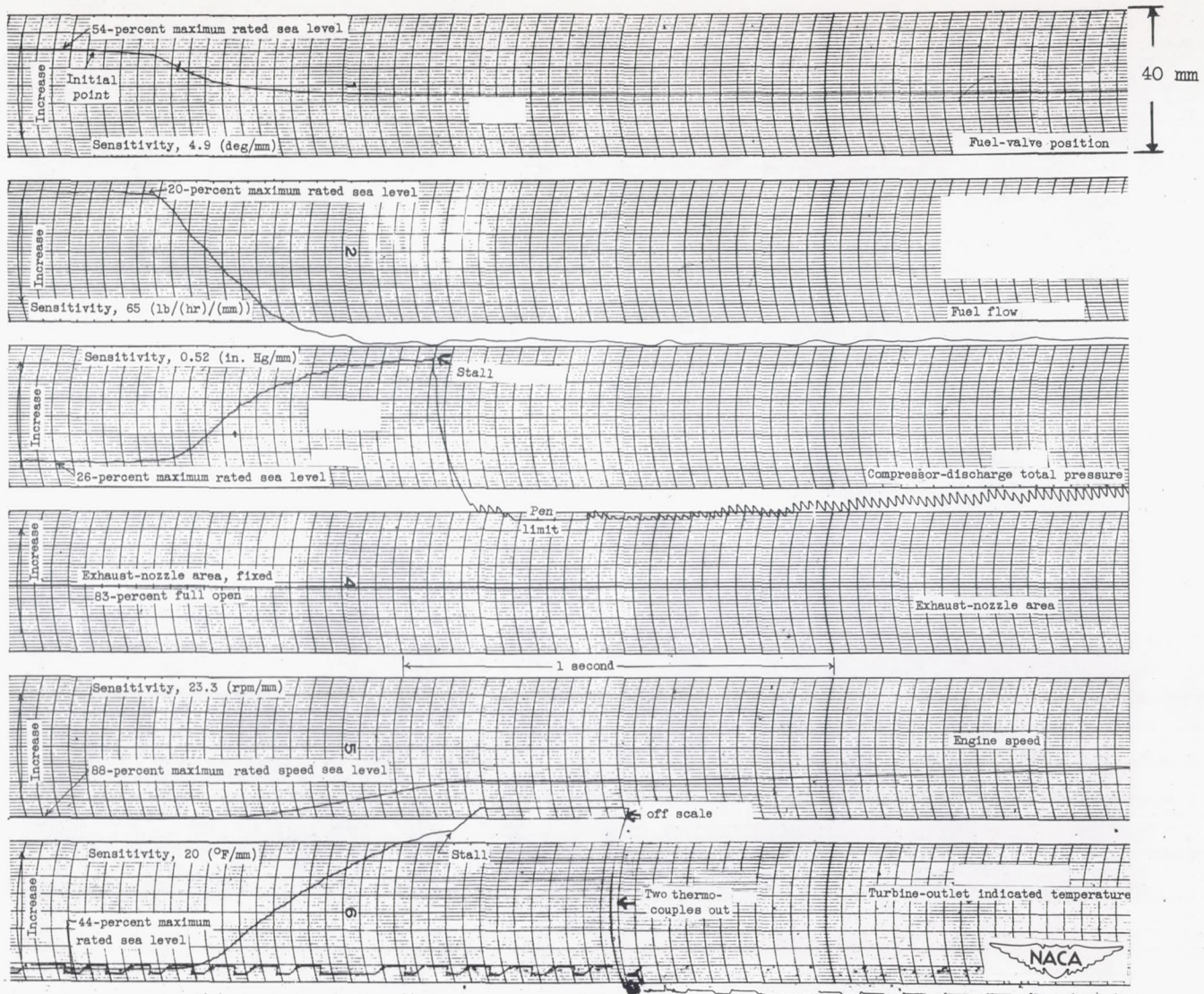

Figure 9. - Time record of several variables during compressor stall in turbojet engine.