

~~SECURITY INFORMATION~~

~~CONFIDENTIAL~~

A. W. Sells

NACA RM A51J18

C-3

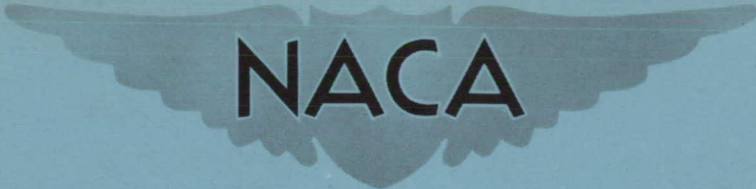

RESEARCH MEMORANDUM

CLASSIFICATION CHANGED TO Unclassified
BY AUTHORITY OF NASA Bull. #114
ON 1/24/67 OF SEC

THE EFFECTIVENESS OF WING VORTEX GENERATORS IN IMPROVING THE
MANEUVERING CHARACTERISTICS OF A SWEEPED-WING
AIRPLANE AT TRANSONIC SPEEDS

By Norman M. McFadden, George A. Rathert, Jr.,
and Richard S. Bray

Ames Aeronautical Laboratory
Moffett Field, Calif.

ENGINEERING DEPT. LIBRARY
CHANCE-VOUGHT AIRCRAFT
DALLAS, TEXAS

CLASSIFIED DOCUMENT

This material contains information affecting the National Defense of the United States within the meaning of the espionage laws, Title 18, U.S.C., and Executive Order 12958, the transmission or revelation of which in any manner to unauthorized person is prohibited by law.

NATIONAL ADVISORY COMMITTEE FOR AERONAUTICS

WASHINGTON

February 28, 1952

~~CONFIDENTIAL~~

RM A51J18

NATIONAL ADVISORY COMMITTEE FOR AERONAUTICS

RESEARCH MEMORANDUM

THE EFFECTIVENESS OF WING VORTEX GENERATORS IN IMPROVING THE
MANEUVERING CHARACTERISTICS OF A SWEEP-WING
AIRPLANE AT TRANSONIC SPEEDS

By Norman M. McFadden, George A. Rathert, Jr.,
and Richard S. Bray

SUMMARY

Several modifications intended to alleviate the effects of shock-induced flow separation have been flight tested at transonic speeds and high altitudes on a swept-wing fighter airplane.

The effects of the modifications on the pitch-up and wing-dropping problems and the buffet boundary, aileron effectiveness, and airplane drag were investigated. Vortex generators were found to be effective in both the wing-dropping and pitch-up problems. The rapid increase in aileron stick force and angle required to hold the wings level above a Mach number of 0.92 was generally reduced and practically eliminated for lg flight with an arrangement of vortex generators at 35-percent chord. The airplane normal-force coefficient at which a loss in lift on the outer portion of the wing caused a longitudinal instability was raised an average of 0.13 in the range of Mach numbers from 0.90 to 0.94 by an arrangement of vortex generators at 15-percent chord. The airplane drag coefficient penalty incurred was negligible with the arrangement at 35 percent of the wing chord, and was 0.0015 at cruising Mach numbers with the arrangement at 15 percent of the wing chord. The drag due to lift was not appreciably affected by either configuration at Mach numbers of 0.82 and 0.86.

Results of limited tests up to a Mach number of 0.94 with multiple boundary-layer fences and with the outer two segments of the wing leading-edge slats extended are presented for comparison.

INTRODUCTION

Flight experience with the F-86A and other swept-wing airplanes, including that described in references 1 and 2, has focussed attention on three problems which affect operation at transonic speeds: buffeting, wing dropping, and the pitch-up at high lift coefficients. The wing-dropping tendency is evident as a rapid increase in the amount of aileron control required to maintain lateral balance while the pitch-up is a longitudinal instability resulting in an uncontrollable nosing-up tendency. Each of these problems has been linked to varying extent with the effects of shock-induced separated flow over the wing.

The NACA is now studying a number of modifications intended to reduce the effects of the flow separation. It has been shown in reference 3 that vortex generators, a development of the United Aircraft Corporation, are effective devices for controlling flow separation. The vortex generators are small wings placed perpendicular to a surface in a flow field in such a manner as to create vortices with their axes alined in the flow direction. Vortex generators of the proper size and arrangement thus provide an intermixing of the retarded flow in the boundary layer with the higher energy flow farther from the surface and, hence, tend to delay separation. The application of vortex generators to shock-induced flow separation is discussed in references 4 and 5. Reference 6 presents results of flight tests of a vortex-generator arrangement on a straight-wing airplane.

The results presented herein are a summary of the information obtained to date with vortex-generator arrangements on a North American F-86A airplane. Also included for comparison purposes are data obtained with multiple boundary-layer fences and with the outer two segments of the wing leading-edge slats extended.

NOTATION

- A aspect ratio
- A_N acceleration normal to airplane body axis (A_N of 1 = $1g$)
- A_L acceleration along airplane body axis, positive when increasing forward velocity.
- C_D airplane drag coefficient ($C_c \cos \alpha + C_N \sin \alpha$)
- C_{D0} drag coefficient at $C_L = 0$

- C_L airplane lift coefficient ($C_N \cos \alpha - C_c \sin \alpha$)
- C_N airplane normal-force coefficient $\left(\frac{WA_N}{qS} \right)$
- C_c airplane chord-force coefficient $\left(\frac{F_N - WA_L}{qS} \right)$
- $C_{l_{\delta_a}}$ rolling-moment coefficient per degree total aileron angle
- $C_{m_{w+f}}$ pitching-moment coefficient of wing-fuselage about $0.25\bar{c}$, $\left(\frac{m}{qS\bar{c}} \right)$
- D total airplane drag, pounds
- F_N net thrust, pounds
- M free-stream Mach number
- S wing area, square feet
- W airplane weight, pounds
- \bar{c} mean aerodynamic chord, feet
- g acceleration due to gravity, 32.2 feet per second squared
- m wing-fuselage pitching moment, foot-pounds
- q free-stream dynamic pressure, pounds per square foot
- α airplane angle of attack, degrees
- δ_{a_R} right aileron angle, degrees, positive down
- δ_{a_L} left aileron angle, degrees, positive down
- δ_{a_T} total aileron angle, degrees, $\left(\delta_{a_L} - \delta_{a_R} \right)$
- $\delta_{a_{av}}$ average aileron angle, degrees, $\left(\frac{\delta_{a_R} + \delta_{a_L}}{2} \right)$

EQUIPMENT AND TESTS

Basic Airplanes and Instruments

The test airplane (fig. 1) was a North American F-86A-5, USAF No. 48-291, with the standard elevator bungee and bobweight removed. These modifications affect only the stick force apparent to the pilot and do not change the elevator hinge moments. Pertinent dimensions are given in table I and in the two-view drawing (fig. 2).

Standard NACA instruments and an oscillograph were used to record the indicated airspeed, altitude, normal and longitudinal accelerations, pitching, rolling, and yawing velocities, control-surface positions, strain-gage outputs, angle of attack, and angle of sideslip. The recordings of the data were synchronized at 1/10-second intervals by a single timing circuit. The true Mach number was obtained from the nose-boom airspeed system using the calibration described in reference 7. The pitching-moment coefficients for the wing-fuselage combination were computed from horizontal tail loads measured by electrical strain gages on the three clevis fittings supporting the adjustable stabilizer and were corrected for the effects of pitching acceleration and inertia loads. The elevator hinge moments were measured by electrical strain gages on the elevator torque tube just inboard of each elevator. The technique used to determine the airplane drag is discussed in the appendix.

Modifications

Locked slats.- The normally free-floating wing leading-edge slats were locked and sealed at the spanwise and chordwise slat joints in all modified configurations. This condition was evaluated, therefore, as a separate modification. The slats were clamped to the basic wing by four bolts in the trailing edge of each of the spanwise segments shown in figure 2 and the joints were sealed with scotch tape.

Vortex generators.- Results are presented for two arrangements of vortex generators designated as configurations A and B. Configuration A was set at the trailing edge of the slats, approximately 15-percent chord, over the outer half of the wing. Dimensions and photographs are shown in figure 3. Configuration B consisted of an arrangement of larger generators in a more rearward location, 35-percent chord, as shown in figure 4. In both cases the angle of incidence of the generators with respect to the free stream was set at about 20° , nose outboard, resulting in an average angle of attack for the generators of approximately 15° , as estimated from tuft photographs. The generators were mounted parallel to one another rather than in alternate pairs as recommended in

reference 3 since unpublished data from a low-speed wind tunnel have shown the parallel arrangement to be more effective on a swept wing. The arrangement used creates vortices with a direction of rotation such as to oppose the outboard flow within the boundary-layer on the swept wing.

Boundary-layer fences.- For comparative purposes a limited amount of data are presented for the multiple boundary-layer-fence configuration shown in figure 5. The fences were basically 5 inches high and extended from the 18-percent-chord point on the lower surface around the leading edge to the 63-percent-chord point on the upper surface. The fences were placed at 36, 53, and 71 percent of the semispan.

Wing-tip-slat extension.- This modification consisted of locking the two outer segments of the leading-edge slats on each wing in the 2/3 extended position. The inner two segments were locked closed. The gap between the extended slats and the wing was left open. Two photographs showing the relative positions of the extended slats and the wing are presented in figure 6. Dimensions are given in table I.

Tests

The tests included measurements of the effects of the modifications on the buffet boundary, the pitch-up (longitudinal instability), wing-dropping tendency, aileron effectiveness, and airplane drag. The following average test conditions were maintained: altitude, 35,000 feet; wing loading, 43.4 pounds per square foot; and center-of-gravity position, 22.5 percent of the wing mean aerodynamic chord. The Reynolds number, based on \bar{c} , varied from 15,500,000 at a Mach number of 0.80 to 19,400,000 at a Mach number of 1.00.

The buffet boundaries were determined from gradual wings-level pull-ups and from pitch-up runs. The maneuvers used to investigate the pitch-up consisted of wind-up, or continuously tightening, turns at constant Mach number up to the actual instability. The wing-dropping tendency was measured in terms of the aileron angle and stick force required to maintain zero rolling velocity in two types of dives at normal-force coefficients below 0.20 up to a Mach number of about 1.00. In the first type, ailerons were used only as required to maintain wings level and no rudder pedal force was applied. In the second type, both aileron and rudder with 300 pounds pedal force were used to maintain as much steady sideslip as possible. The aileron effectiveness (the variation of rolling moment with aileron angle) was computed directly from measurements of the rolling acceleration at zero rolling velocity in the manner suggested in reference 8. The airplane drag was determined from measurements of the tail-pipe total pressure and acceleration forces acting on

the airplane in constant-speed runs as shown in the appendix. In order to check the accuracy of the method of evaluating the thrust, where possible data were obtained at three different power settings at each speed.

One point concerning the test program deserves extra consideration in interpreting the results. Since a flow-separation phenomenon is involved, a number of factors other than the parameters actually discussed affect the test comparisons, particularly pitching velocity, rate of control movement, and wing surface condition. Such factors, especially those involving pilot technique, have been held as constant as practicable in making the comparisons shown.

RESULTS AND DISCUSSION

Buffet Boundary

The buffet boundaries for the production airplane and two modified configurations are shown in figure 7. The criterion used, buffeting accelerations of the order of $\pm 0.03g$ at the center of gravity, is explained in reference 9. The largest change in the buffet boundary was obtained by locking the slats, presumably because this eliminated the 48-cycle-per-second vibration of the slats which predominates in the buffeting characteristics of the production airplane, noted in reference 1.

As figure 7 shows, however, vortex-generator configuration A gave some further improvement. This is attributed to an effective reduction in the extent of separated flow on the wing which may be seen by examining figures 8 and 9. The changes in the aileron floating angle caused by the vortex generators are shown in figure 8. The tuft photographs in figure 9 indicate, by the obvious differences in tuft behavior before and after the abrupt up-floating tendency, that the amount of aileron floating angle is a good indication of the intensity of separated flow on the wing. The data in figure 8 show that the sharp upward break in floating angle with increasing normal-force coefficient is postponed to higher normal-force coefficients by the vortex generators, and the floating angle is appreciably less at the normal-force coefficients noted on the figure where buffeting appears on the original configuration.

It is difficult to assess the importance of the magnitude of the changes shown in figure 7 since the increase in buffet intensity with penetration beyond the buffet boundary remains comparatively low at the altitude of the tests even on the production airplane. In the opinion of the NACA pilots the maneuverability is limited by the pitch-up problem rather than buffeting.

Pitch-Up

Within the buffeting region the maneuverability is limited between Mach numbers of 0.75 and 0.94 by a reversal of the variation of elevator stick force and position with normal acceleration which makes it difficult to attain higher accelerations without "overshooting" or inadvertently pitching up to a stall. The investigation reported in reference 10 has shown that an abrupt reduction in the stability of the wing-fuselage combination caused by loss of lift on the outer portion of the wing is responsible. The flow separation near the wing tips and the resulting inboard and, consequently, forward shift of the center of pressure are documented in reference 10.

The effect of vortex-generator configuration A on the wing-fuselage pitching-moment characteristics at four Mach numbers is presented in figure 10. The comparison is made with the slats-locked, wing-sealed configuration rather than the production airplane since more suitable data are available and since that modification had little effect on the pitch-up characteristics. The vortex generators delay the unstable break in the wing-fuselage pitching-moment curves to higher normal-force coefficients at Mach numbers of 0.91 and 0.93, the greatest increase being from a normal-force coefficient of 0.31 to 0.45 at a Mach number of 0.91.

The extension due to the vortex generators of the range of normal acceleration for which the control characteristics were satisfactory at 35,000 feet altitude is shown in figure 11. Figure 11(a) shows the increase in elevator hinge moment required for balance at high accelerations. Hinge moments rather than the more familiar stick forces are presented to exclude the effects of the power-boost system and control linkages. The changes in the corresponding variations of elevator angle with normal acceleration are presented in figure 11(b).

The effectiveness of the vortex generators in improving the wing-fuselage stability characteristics is compared with that of the multiple boundary-layer fences in figure 12. At a Mach number of 0.93 the normal-force coefficient for the change in stability is 0.30 for the locked-slat configuration, 0.43 with the vortex-generator arrangement, and 0.53 with the fences. Figure 12 is shown primarily to indicate that further improvement is possible by modifying the flow characteristics, since the vortex-generator configuration used is obviously not necessarily an optimum.

The limits of the Mach number range wherein the vortex generators are effective are brought out more clearly by figure 13, which summarizes the effect of Mach number on the normal-force coefficient for the change in stability of the wing-fuselage combination. As noted in the figure

and discussed in reference 10, above a Mach number of 0.95 no abrupt changes in stability have been encountered up to a normal-force coefficient of 0.70, the test limit. The effectiveness of the vortex generators is significant only between Mach numbers of 0.88 and 0.94 where buffeting and separated flow appear at considerably lower normal-force coefficients than at low speed. It is believed, on the basis of the aileron floating characteristics (fig. 8), and observations of motion pictures of tuft behavior, that shock-induced trailing-edge flow separation is the predominant factor changing the characteristics of the wing in this Mach number range and that some form of leading-edge flow separation occurs at the lower speeds where the vortex generators are relatively ineffective.

Additional evidence supporting this belief is supplied by the effect of a modification to the flow conditions at the leading edge, the extension of the outer two segments of the wing leading-edge slats. As shown in figure 14 by the wing-fuselage pitching-moment characteristics, at a Mach number of 0.80 the slat extension effectively eliminates the abrupt reduction in stability and produces a stable stall. At a Mach number of 0.92 where the vortex generators are effective, the slat extension is completely ineffective, actually reducing the normal-force coefficient at which the instability appears.

Figure 13 serves as a summary of the improvement in maneuvering acceleration provided by the vortex generators and the fences. At the test altitude of 35,000 feet the increase is from a normal acceleration of 2.0g's to 2.9g's at a Mach number of 0.91. The computed lines added to the figure are for constant normal acceleration at 20,000 feet and indicate, assuming no aeroelastic effects, an increase from 4.0g's to 5.7g's.

It should be emphasized that the data in figure 13 indicate only an increase in the useful range of normal-force coefficient or acceleration. Reference to the individual pitching-moment characteristics (figs. 10 and 12) shows that although the vortex generators and boundary-layer fences delay the pitch-up to higher normal-force coefficients or higher accelerations, they neither eliminate nor alleviate the intensity of the pitch-up and, hence, do not lessen the danger of this characteristic if the acceleration attained is close to the maximum design acceleration.

Vortex-generator configuration B, the larger and more rearward arrangement, was developed and tested to increase the alleviation of the wing-dropping tendency and the effects on the pitch-up characteristics were not documented. As a matter of interest, however, the pilot impressions were reviewed and indicate that configuration B probably was appreciably less effective in improving the pitch-up characteristics than configuration A. Also, in view of the obvious superiority of the

fences indicated by figure 13, reference is made to their prohibitive effect on performance discussed in a following section.

Wing Dropping

The wing-dropping tendency on the test airplane is made evident by a rapid increase in the amount of aileron deflection and force required to hold the wings level at high subsonic Mach numbers. It appears that this tendency is due to the shock-induced separation on the wing causing a decrease in aileron effectiveness and an increase in the rolling moment due to sideslip which must be trimmed by the ailerons (references 2 and 11). On this basis vortex generators might be expected to alleviate the wing-dropping tendency either by increasing the effectiveness of the aileron control or by reducing the asymmetry of the separated flow induced by sideslip.

It is difficult to obtain repeatable quantitative data with regard to the wing heaviness of an airplane unless the manner of making the maneuver is closely controlled. The most significant variables are the use of aileron control and the sideslip. The use of ailerons is important because the aileron characteristics are nonlinear in the Mach number range under consideration. For some conditions there is a reversal of aileron effectiveness at small aileron angles and the wing dropping can be checked by applying opposite aileron (right rolling velocity produced by left aileron deflection). An example of this is shown in figure 15 by comparison of the time histories of rolling velocity and aileron angle (rudder position being held fixed and sideslip varying less than $\pm 1/4^\circ$). It is apparent that rolling velocity is in the opposite direction to the applied aileron angle through several reversals of direction. Therefore in the range of this reversal the pilot can either, by attempting to operate the ailerons in the normal sense, make a mild wing dropping seem much more severe, or, by operating the ailerons in the reversed sense, check the wing dropping altogether at small sideslip angles. The steady-state wing-dropping data (fig. 16), from which the modifications are evaluated, are for the ailerons deflected in the normal sense at angles beyond that at which the reversed effectiveness exists.

The sideslip is an important variable because even small amounts of sideslip, to which the pilot is relatively insensitive, affect the probability of the occurrence of the wing dropping, the direction of the roll, and the Mach number at which it occurs (0.92 to 0.96 Mach number on the test airplane). In view of this, the effect of the vortex generators was measured for the extreme sideslipping conditions of 300-pounds right and left rudder-pedal force as well as for the normal condition of low-lift wings-level dives with no rudder-pedal force.

These conditions represent the extremes in sideslip resulting from likely differences in built-in asymmetry, pilot technique, and manner of entry into the dive.

The variations of aileron position, stick force, and sideslip angle with Mach number are presented in figure 16 for the production airplane and for the vortex generator configurations A and B at lift coefficients corresponding to level flight.¹ Due to the variable effects of the flight conditions just discussed, the changes in Mach number for the wing dropping are not considered to be significant and the modifications are evaluated on the basis of the relative amounts of aileron stick force and position required to maintain lateral balance.

A comparison between figures 16(a) and 16(b) shows that vortex-generator configuration A reduced the wing-dropping tendency in the no-pedal-force case. The maximum aileron angle required was reduced from 13° to 1.5° and the stick force from 9.5 pounds to 4.0 pounds; however, the wing-dropping tendency was not significantly reduced under the extreme sideslipping conditions.

Further alleviation of the wing-dropping tendency was obtained by changing to larger generators mounted farther back on the wing at the 35-percent-chord point, configuration B. Comparison of figures 16(a) and 16(c) shows that the wing-dropping tendency in the wings-level no-pedal-force dive was practically eliminated. For the dive with 300-pounds right pedal force, the maximum aileron angle was reduced from 13° to 4.5° and the stick force from 13.5 pounds to 3 pounds.

Figure 16 presented data for the lift-coefficient range corresponding to level-flight values (0.05 to 0.15). Some indication that the improvement provided by the vortex generators may not be as satisfactory at higher lift coefficients is shown by the time history in figure 17. In this one circumstance, a pull-out from a high-speed dive in which a lift coefficient of approximately 0.3 was achieved at maximum sideslip angle required 9.6° total aileron angle and 7-pounds stick force for lateral balance even with vortex-generator configuration B installed. These values are of the same order as those shown in figure 16(a) for the wing dropping of the production airplane at level-flight lift coefficients.

¹The data for the production airplane (fig. 16(a)) are for the normal condition of slats operative and unsealed. The slats were locked and sealed with the vortex generators installed. A separate evaluation of the effect of sealing the slats indicated a minor effect on the Mach number at which wing dropping occurred but no effect on the magnitude of the aileron angle and force required for trim, the bases for evaluating the modifications.

It was not possible to determine how much of the improvement due to the vortex generators was caused by an increase in aileron effectiveness and how much was due to a decrease in the out-of-trim rolling moment. The limited data relative to $C_{l\delta_a}$, which were obtained by the method of reference 8, are shown in figure 18. The data cannot be used to compare the aileron effectiveness of the two configurations because of the aforementioned nonlinearity in aileron effectiveness with aileron deflection. The figure does show, however, that there is still a marked reduction in aileron effectiveness at 0.96 Mach number with the vortex generators installed despite the fact that this configuration provided a definite improvement in the wing-dropping characteristics.

Although data are not presented herein to show their effects on the wing-dropping characteristics, it is of interest to note that the boundary-layer fences and wing-tip slat extension had a negligible effect on this problem.

A warning note is justified with regard to attempts to apply vortex generators to other airplanes to decrease the high Mach number wing-dropping tendency. It is apparent that the unsymmetrical separation causing the out-of-trim rolling moment may be so severe that the vortex generators will fail to relieve the condition. It is suggested that this dissymmetry should first be minimized by adjustments in the directional trim of the airplane until it is possible to make the airplane become wing heavy in either direction by use of the rudder. In such a case the present test results then indicate that the vortex generators are likely to be sufficiently effective to cope with inadvertent deviations in sideslip introduced by the pilot due to manner of entry into the dive or maneuver.

Performance

The changes in airplane drag caused by the vortex generators are shown in figures 19 and 20. Figure 19, the variation with Mach number of the drag coefficient at a lift coefficient of 0.15, indicates that the increase in minimum drag coefficient caused by configuration A is 0.0015 at Mach numbers in the normal cruising range and 0.0025 at supersonic speeds. The effects on the drag coefficient caused by vortex-generator configuration B, the more rearward arrangement, are negligible at all speeds.

The groups of test points in figure 19 near Mach numbers of 0.70, 0.81, 0.86, and 0.91 were obtained for engine power settings varying from 70- to 100-percent full power in each group. The small amount of scatter in the computed drag coefficient is an indication that the

thrust calculations are sufficiently accurate to justify a comparison of drag-coefficient increments of the order of 0.0010 at those Mach numbers.

The variations of drag coefficient with lift coefficient at Mach numbers of 0.82 and 0.86 are presented in figure 20. The fairings shown, the true parabolas best fitted to the available test points, indicate that there is no appreciable effect on the drag due to lift up to a lift coefficient of about 0.4. The "Oswald efficiency factor" for a symmetrical wing,

$$e = \frac{C_L^2}{\pi A (C_D - C_{D0})}$$

has a value of approximately 0.6 at both Mach numbers in all configurations.

Although drag measurements were not obtained, it must be noted that the large boundary-layer fences which were the most effective in dealing with the pitch-up problem resulted in noticeable reductions in rate of climb (below 0.88 Mach number) and in maximum speed. The maximum altitude attainable was reduced about 5,500 feet by the fences; whereas no reduction had been noted with the vortex-generator arrangements.

CONCLUDING REMARKS

Measurements of the effects of vortex generators on the stability, control, and performance characteristics of a swept-wing airplane at transonic speeds have indicated:

1. The wing-dropping tendency above a Mach number of 0.92 was alleviated appreciably in sideslipping flight and practically eliminated in normal low-lift, wings-level dives by an arrangement at 35-percent chord. The tendency was still encountered in sideslipping flight in a pull-out at a normal-force coefficient of 0.25, however.
2. Between Mach numbers of 0.90 and 0.94, the normal-force coefficient at which separated flow on the wing tips produced a pitch-up, or longitudinal instability, was raised an average of 0.13 by an arrangement at 15-percent chord.
3. The drag penalty incurred was negligible with the arrangement of vortex generators at 35 percent of the wing chord and was about 0.0015 at cruising Mach numbers with the arrangement at 15 percent of the wing chord. The drag due to lift was not appreciably affected by either configuration at Mach numbers of 0.82 and 0.86.

Limited tests of two other modifications were significant in two respects. Large multiple boundary-layer fences were more effective than vortex generators in delaying the pitch-up between Mach numbers of 0.88 and 0.94 but caused a reduction in performance. The extension of the outer two segments of the wing leading-edge slats was effective in alleviating the pitch-up at a Mach number of 0.80 but was completely ineffective at a Mach number of 0.92.

Ames Aeronautical Laboratory
National Advisory Committee for Aeronautics
Moffett Field, Calif.

APPENDIX

THE DETERMINATION OF DRAG

The drag as presented in this report was determined from the following equation

$$D = W(A_N \sin \alpha - A_L \cos \alpha) + F_N \cos \alpha$$

where

- D drag of airplane, pounds
 W weight of airplane, pounds
 A_N normal acceleration factor
 A_L longitudinal acceleration factor
 α angle of attack, degrees
 F_N net thrust, pounds

The weight of the airplane was determined from take-off weight and the amount of fuel used between the take-off and the time of the run. The longitudinal acceleration was measured by an accelerometer which is sensitive to 0.0025g. The angle of attack was obtained from the normal-force-curve slope for this airplane, measured during previous tests.

The gross thrust was calculated from the following isentropic relationships which were derived from reference 12:

$$\begin{aligned} \frac{F_g}{P_c A} &= \frac{2\gamma}{\gamma-1} \left[\left(\frac{P_T}{P_j} \right)^{\frac{\gamma-1}{\gamma}} - 1 \right] \text{ for } \frac{P_T}{P_j} < \left(\frac{\gamma+1}{2} \right)^{\frac{\gamma}{\gamma-1}} \\ &= \left[\frac{2P_T}{P_j} \left(\frac{2}{\gamma+1} \right)^{\frac{1}{\gamma-1}} - 1 \right] \text{ for } \frac{P_T}{P_j} \geq \left(\frac{\gamma+1}{2} \right)^{\frac{\gamma}{\gamma-1}} \end{aligned}$$

where

- P_T tail-pipe total pressure, pounds per square foot
 P_0 free-stream static pressure, pounds per square foot
 P_j tail-pipe static pressure, pounds per square foot
 γ ratio of specific heats (assuming $\gamma = 1.33$ at the tail-pipe exit)
 F_g gross thrust, pounds
 A tail-pipe area, square feet

The total pressure in the tail pipe was measured by a single total-pressure probe mounted in the jet-engine tail pipe and a uniform distribution of temperature and pressure in the tail pipe was assumed. It was also assumed that the static pressure in the tail-pipe exit was equal to free-stream static pressure and that there were no nozzle losses.

The net thrust used in the drag equations was obtained from

$$F_N = F_g - \frac{W_a}{g} V$$

where

- W_a weight of air through engine, pounds per second
 g acceleration due to gravity, feet per second squared
 V airplane velocity, feet per second

Because no station on the airplane was instrumented sufficiently to determine rate of air flow through the engine directly, it was necessary for this investigation to estimate the air flow from an altitude wind-tunnel test (reference 13) of an engine of the same type. It was assumed that the loss in total pressure at the face of the compressor inlet was 5 percent of the free-stream dynamic pressure.

REFERENCES

1. Rathert, George A., Jr., Ziff, Howard L., and Cooper, George E.: Preliminary Flight Investigation of the Maneuvering Accelerations and Buffet Boundary of a 35° Swept-Wing Airplane at High Altitude and Transonic Speeds. NACA RM A50L04, 1951.
2. Rathert, George A., Jr., Rolls, L. Stewart, Winograd, Lee, and Cooper, George E.: Preliminary Flight Investigation of the Wing-Dropping Tendency and Lateral-Control Characteristics of a 35° Swept-Wing Airplane at Transonic Mach Numbers. NACA RM A50H03, 1950.
3. Taylor, H. D.: Design Criteria for and Applications of the Vortex Generator Mixing Principle. United Aircraft Corp., Res. Dept. M-15038-1, Feb. 16, 1948.
4. Donaldson, Coleman duP.: Investigation of a Simple Device for Preventing Separation Due to Shock and Boundary-Layer Interaction. NACA RM L50B02a, 1950.
5. Lina, Lindsay J., and Reed, Wilmer H., III.: A Preliminary Flight Investigation of the Effects of Vortex Generators on Separation Due to Shock. NACA RM L50J02, 1950.
6. Beeler, De E., Bellman, Donald R., and Griffith, John H.: Flight Determination of the Effects of Wing Vortex Generators on the Aerodynamic Characteristics of the D-558-I Airplane. NACA RM L51A23, 1951.
7. Thompson, Jim Rogers, Bray, Richard S., and Cooper, George E.: Flight Calibration of Four Airspeed Systems on a Swept-Wing Airplane at Mach Numbers Up to 1.04 by the NACA Radar-Phototheodolite Method. NACA RM A50H24, 1950.
8. Anderson, Seth B., Ernst, Edward A., and Van Dyke, Rudolph D., Jr.: Flight Measurements of the Wing-Dropping Tendency of a Straight-Wing Jet Airplane at High Subsonic Mach Numbers. NACA RM A51B28, 1951.
9. Gadeberg, Burnett L., and Ziff, Howard L.: Flight Determined Buffet Boundaries of Ten Airplanes and Comparisons with Five Buffeting Criteria. NACA RM A50I27, 1951.

10. Anderson, Seth B., and Bray, Richard S.: A Flight Evaluation of the Longitudinal Stability Characteristics Associated With the Pitch-Up of a Swept-Wing Airplane in Maneuvering Flight at Transonic Speeds: NACA RM A51112, 1951.
11. Purser, Paul E.: Notes on Low-Lift Buffeting and Wing Dropping at Mach Numbers Near 1. NACA RM L51A30, 1951.
12. Coleman, Robert V., and Cochran, John T.: Phase II Flight Tests of the XF-91 Airplane, USAF No. 46-680. AMC, Flight Test Div. Memo Rept., Serial MCRFT-2272, 1950.
13. Conrad, E. William, and Sobolewski, Adam E.: Altitude-Wind-Tunnel Investigation of J47 Turbojet-Engine Performance. NACA RM E9G09, 1949.

TABLE I.- DIMENSIONS OF TEST AIRPLANE

Wing	
Area	287.9 sq ft
Span	37.1 ft
Aspect ratio	4.79
Taper ratio	0.51
Dihedral	3°
Sweepback of 0.25 chord line	35°14'
Aerodynamic and geometric twist (washout)	2°
Root airfoil section (normal to 0.25 chord line)	NACA 0012-64 (modified)
Tip airfoil section (normal to 0.25 chord line)	NACA 0011-64 (modified)
Mean aerodynamic chord (wing station 98.7 in.)	8.09 ft
Outer two segments of leading-edge slats (one side only)	
Span (along trailing edge of slat)	9.0 ft
Area	9.75 sq ft
Chord, perpendicular to trailing edge of slat, (constant)	1.08 ft
Ailerons	
Area, each	18.6 sq ft
Span	9.18 ft
Chord, average	2.03 ft
Deflection, maximum	14° up, 14° down
Boost	hydraulic
Aerodynamic balance	curtain sealed, paddle balance
Inboard end at	51.6% b/2
Horizontal tail	
Area	35.0 sq ft
Span	12.8 ft
Aspect ratio	4.65
Taper ratio	0.45
Sweepback of 0.25 chord line	34°35'
Airfoil section (parallel to center line)	NACA 0010-64
Deflection, maximum	1° stabilizer nose up, 10° down
Mean aerodynamic chord (horizontal-tail station 33.54 in.)	2.89 ft

TABLE I.- CONCLUDED

Elevators	
Area (both sides)	10.1 sq ft
Span (each)	5.8 ft
Deflection, maximum	35° up, 17.5° down
Boost	hydraulic
Vertical tail	
Area, total	34.4 sq ft
Span	7.5 ft
Aspect ratio	1.74
Taper ratio	0.36
Sweepback of 0.25 chord line	35°0'
Rudder	
Area	8.1 sq ft
Span	6.6 ft
Chord, average	1.23 ft
Deflection, maximum	24.8° right, 25° left



Page intentionally left blank

Page intentionally left blank

~~CONFIDENTIAL~~

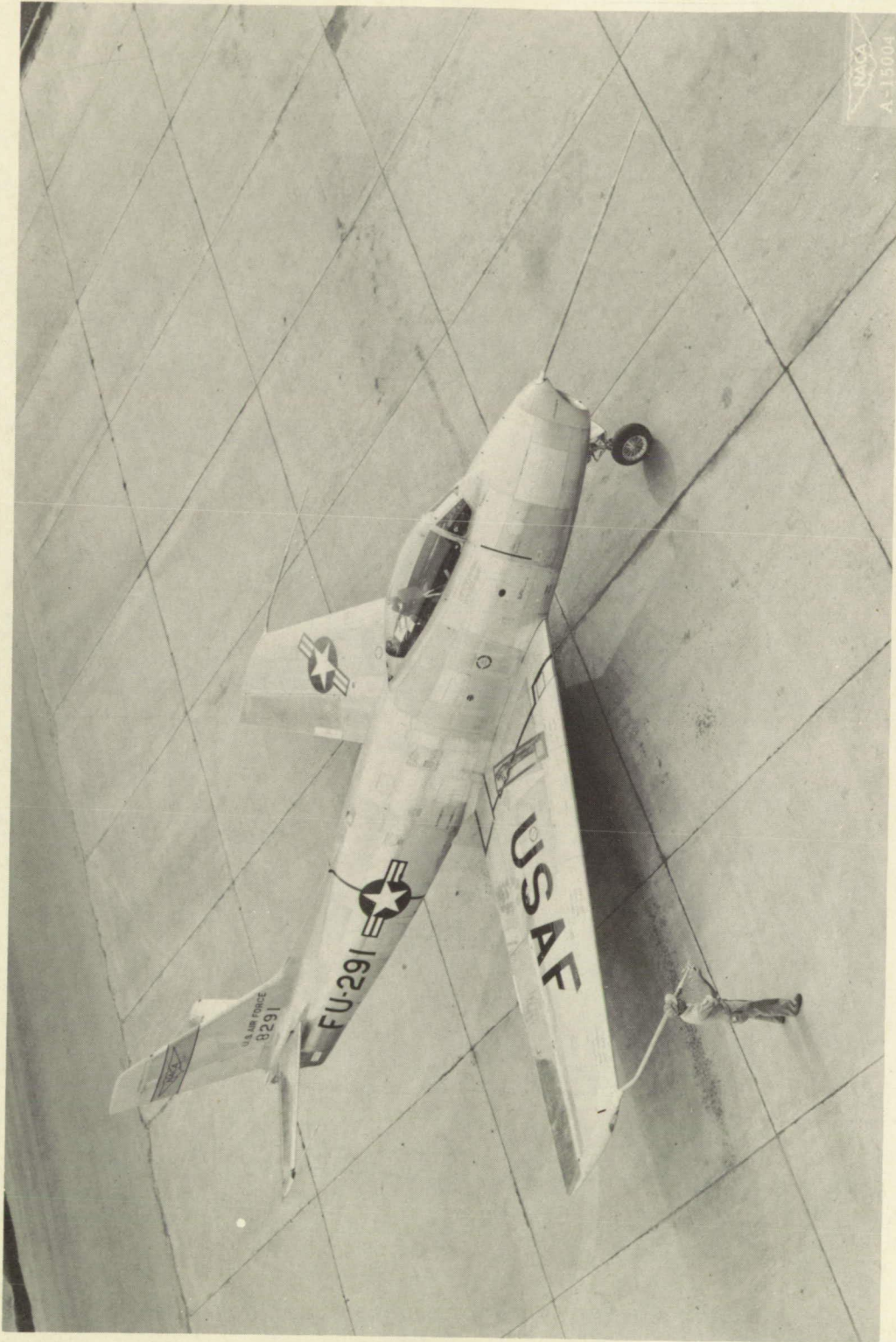

Figure 1.- The test airplane.

~~CONFIDENTIAL~~

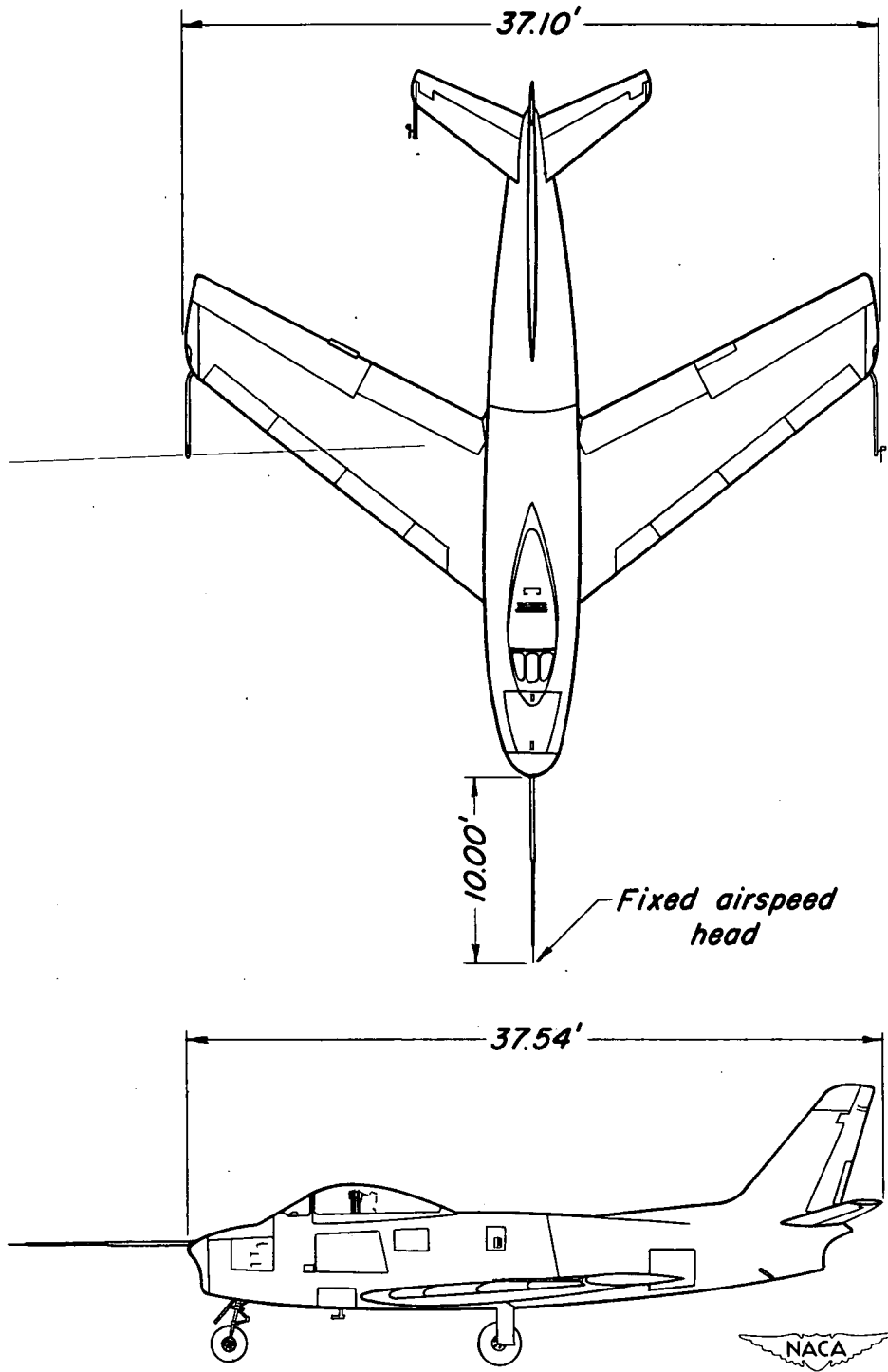
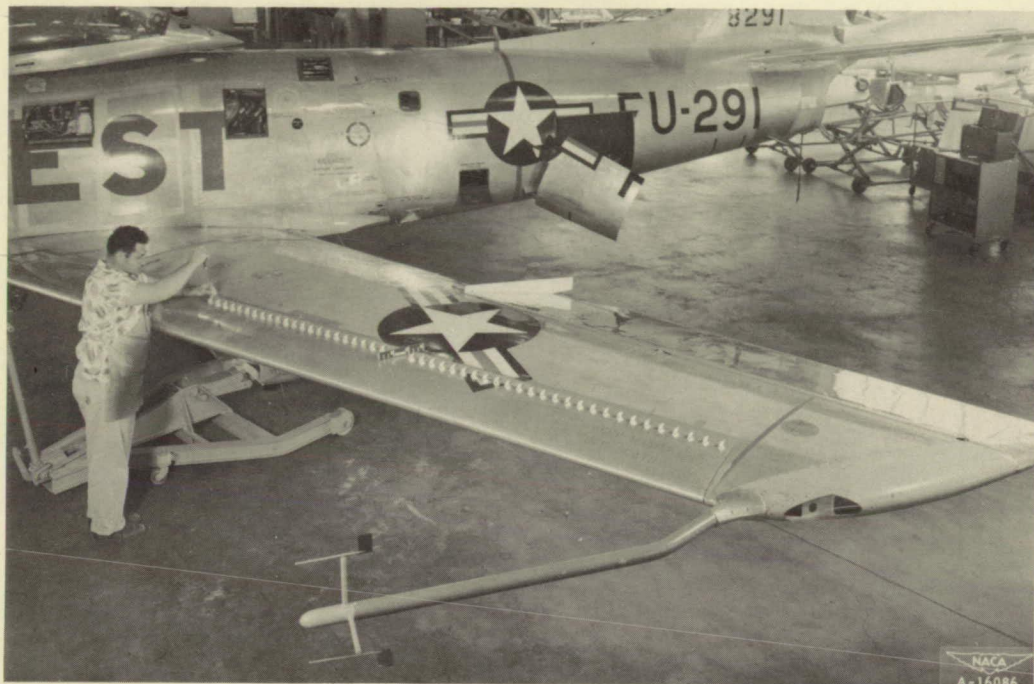
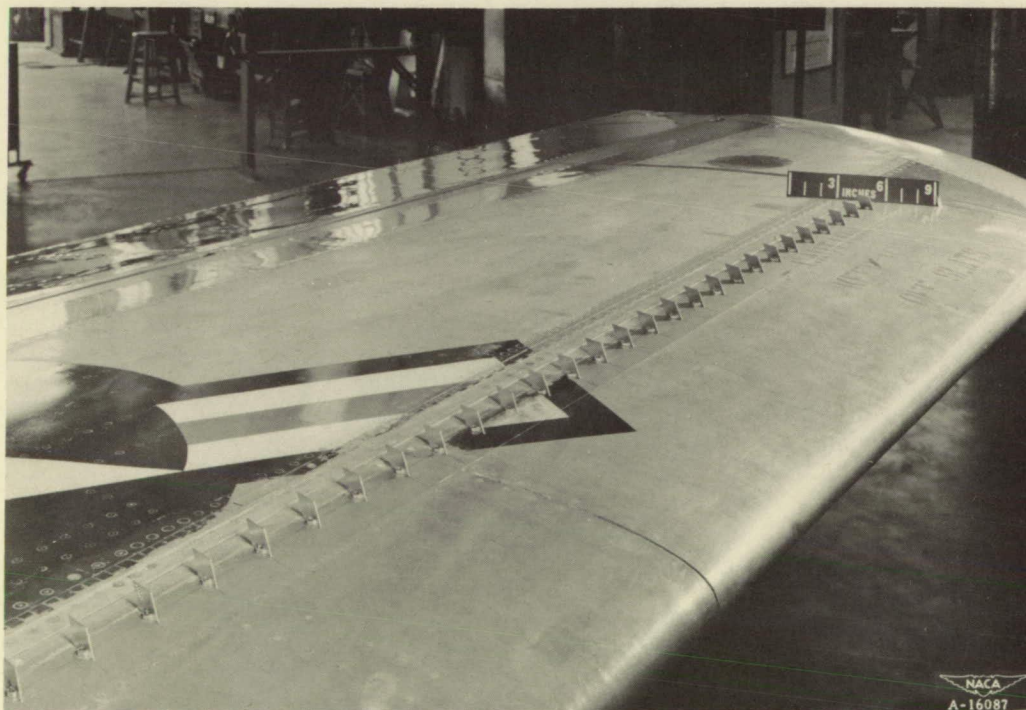

Figure 2.-Two-view drawing of test airplane.



(a) General view.



(b) Detail.

Figure 3.- Vortex-generator configuration A.

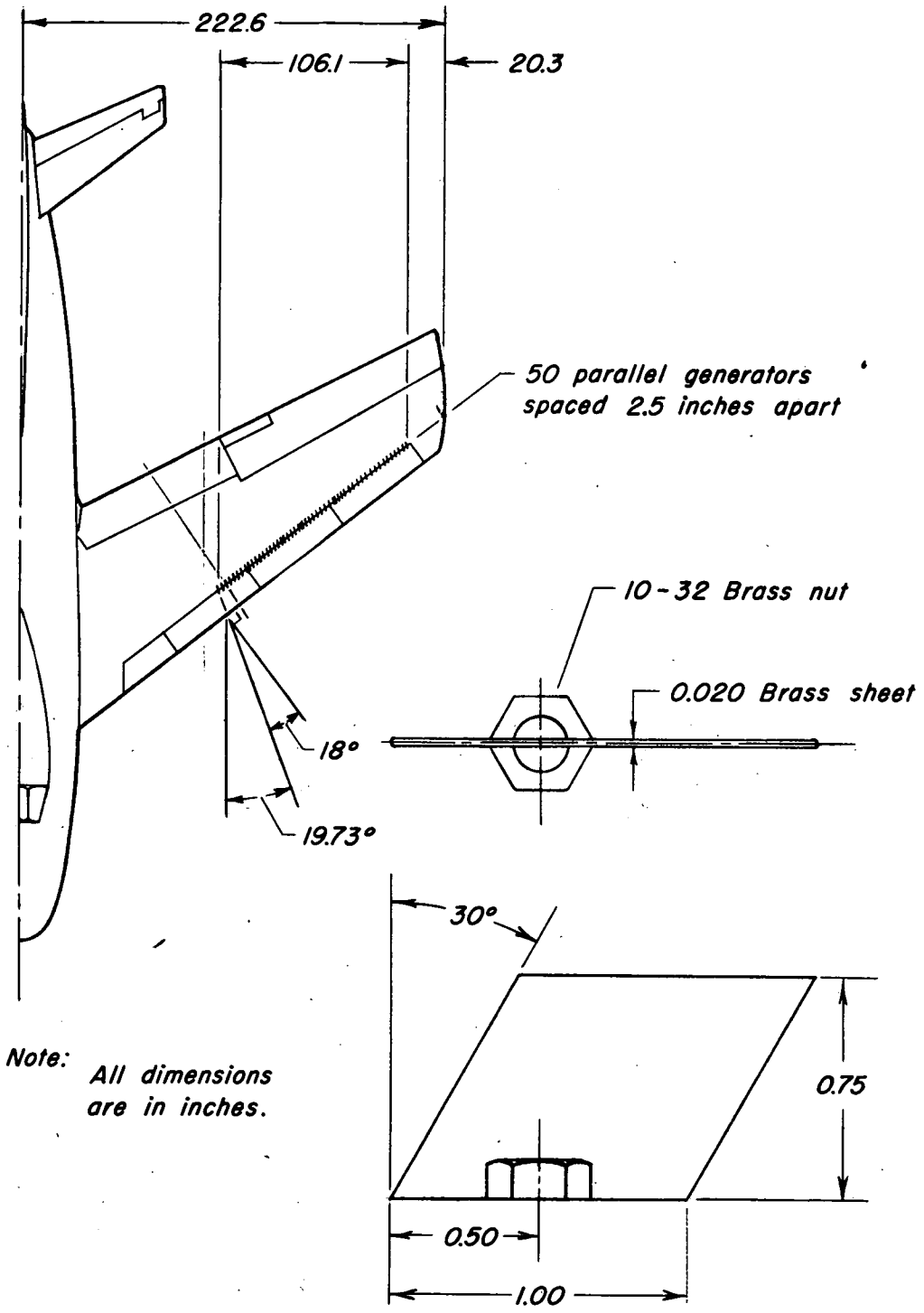

Note: All dimensions are in inches.



(c) Dimensions.
Figure 3.- Concluded.

~~CONFIDENTIAL~~



(a) Detail.

Figure 4.- Vortex-generator configuration B.

~~CONFIDENTIAL~~

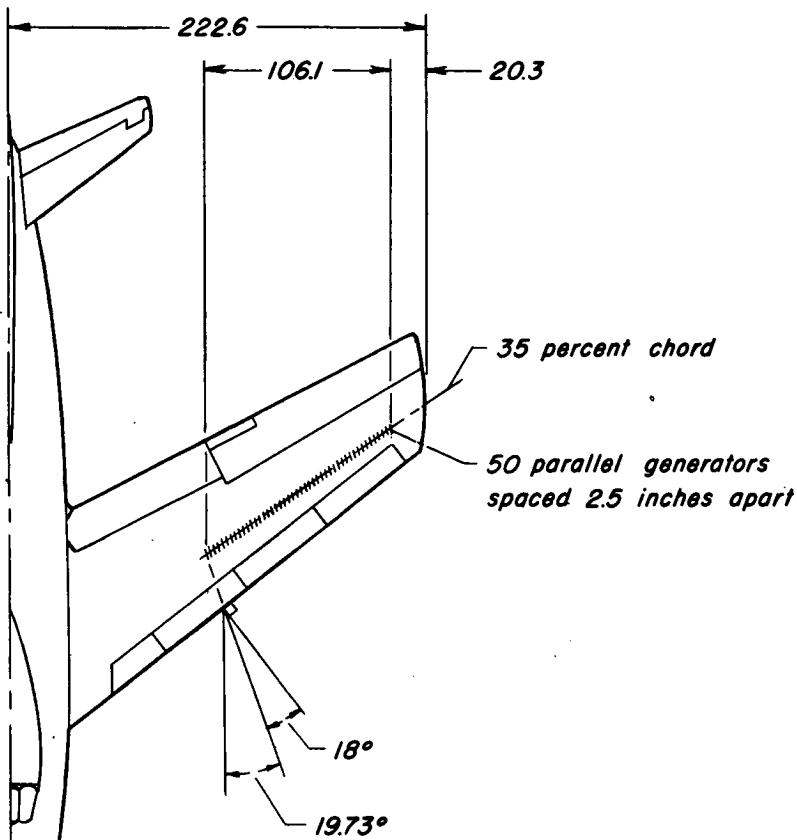

Note: All dimensions are in inches.

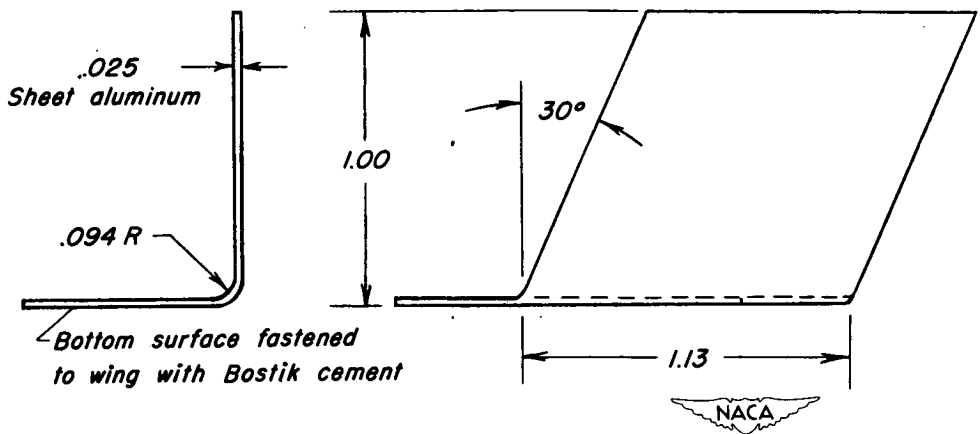

(b) Dimensions.

Figure 4.- Concluded.



(a) General view.

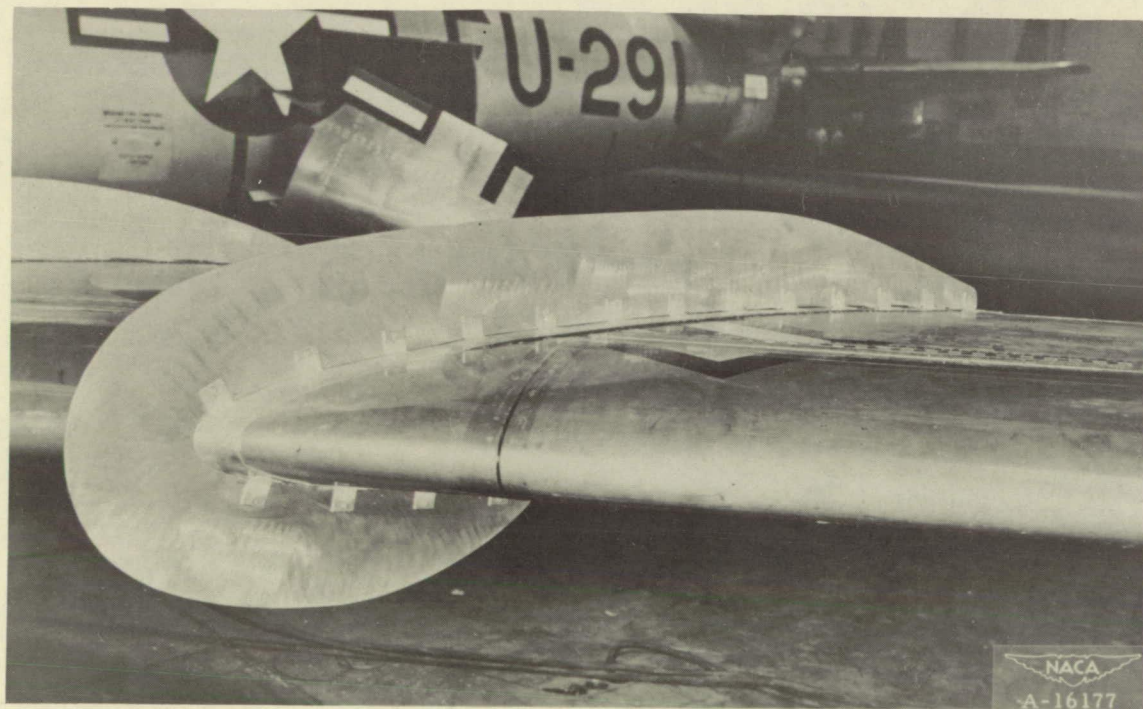

(b) Detail.

Figure 5.- The multiple boundary-layer-fence installation.

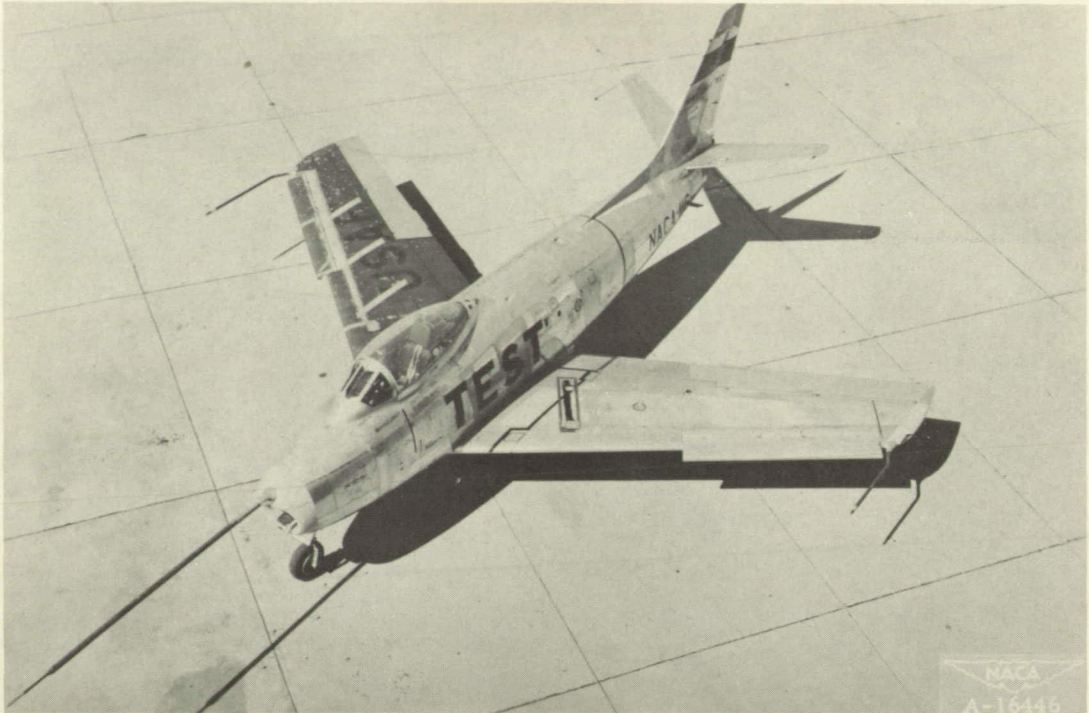

(a) General view.

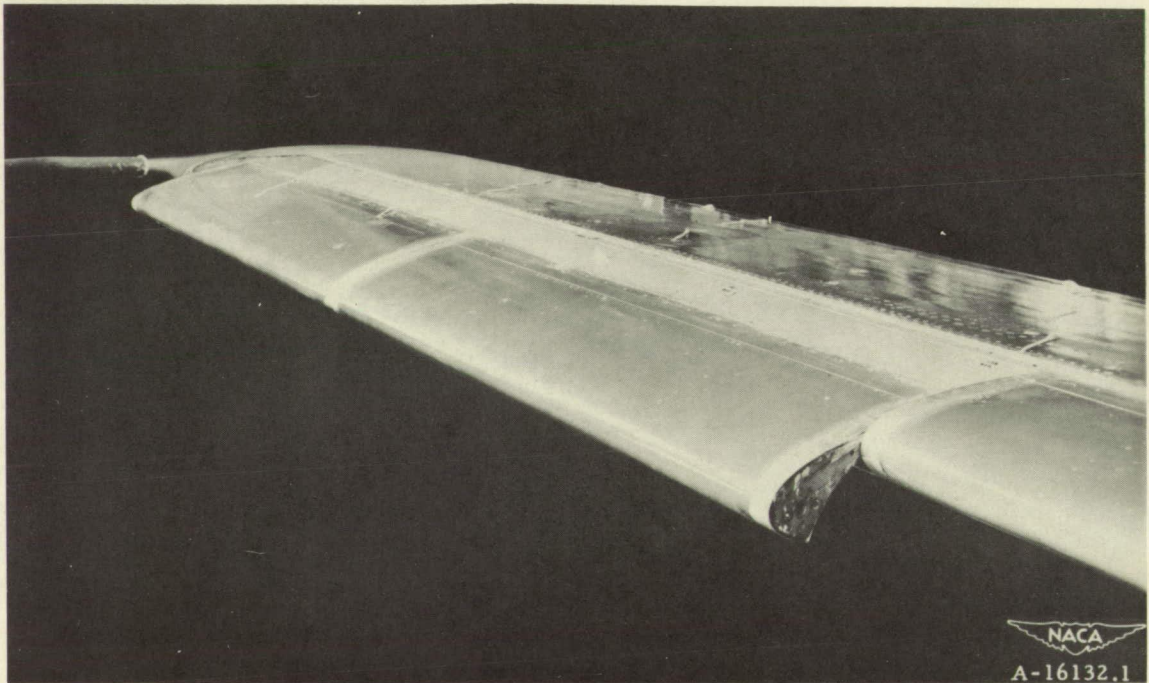

(b) Detail.

Figure 6.- The extended wing-tip leading-edge slat modification.

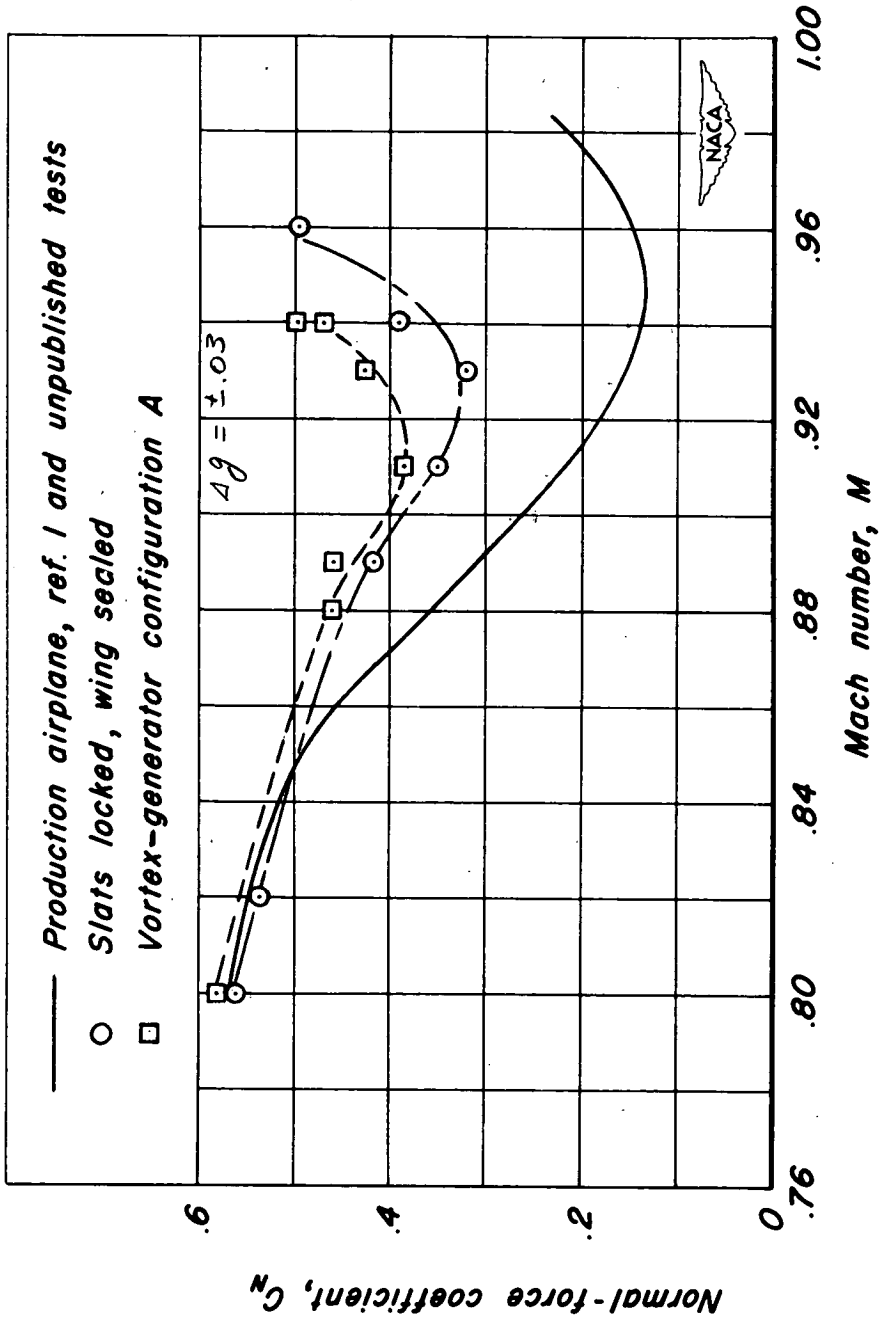

Figure 7.- The effects of the slats-locked and vortex-generator modifications on the buffet boundary.

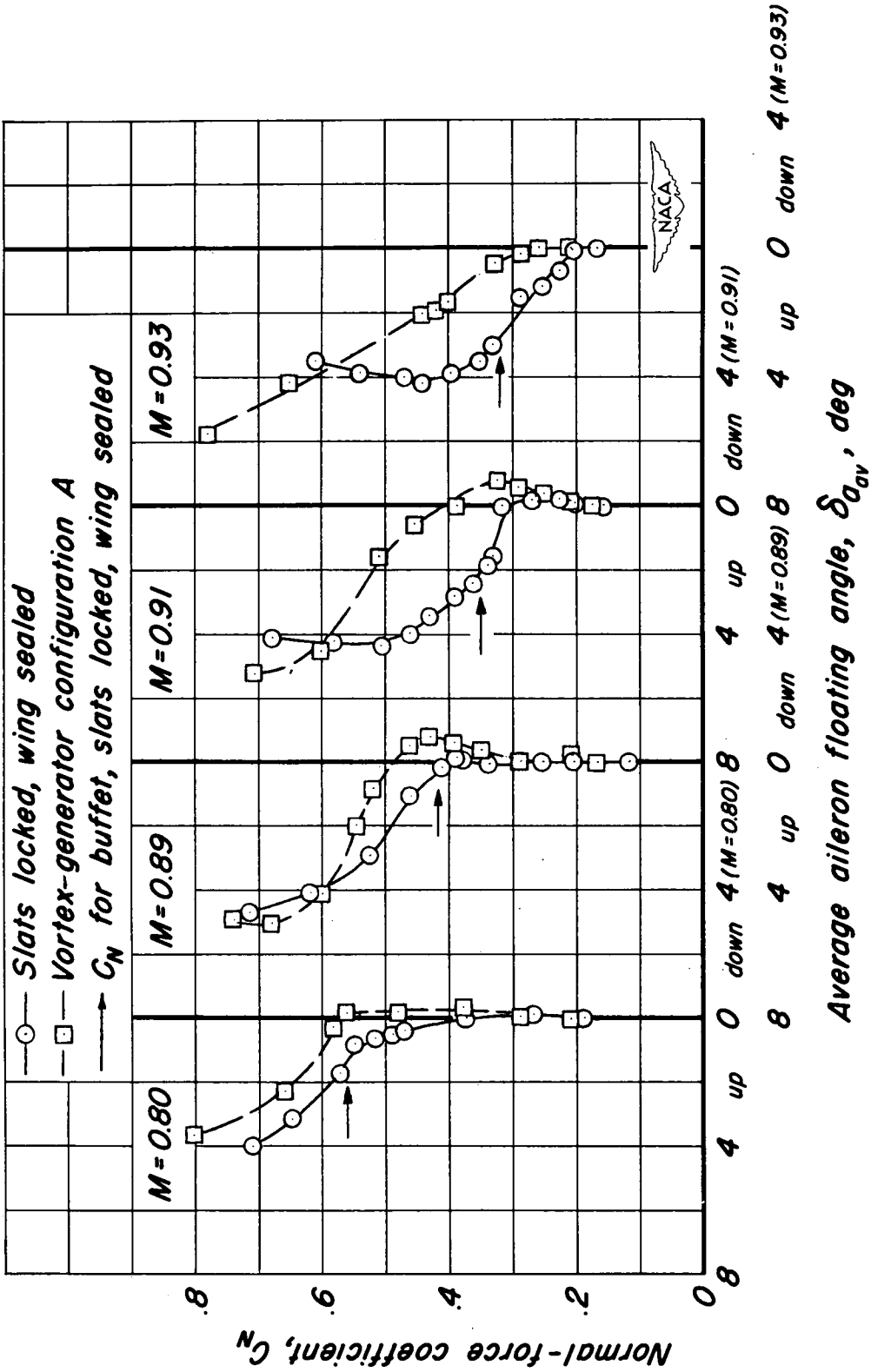
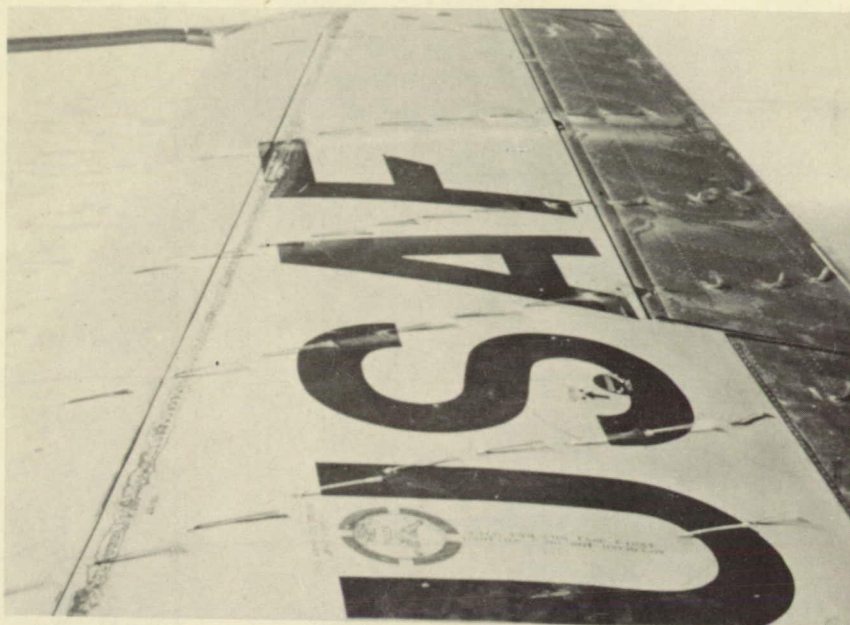

Figure 8.—The effect of vortex-generator configuration A on the variation of aileron floating angle with normal-force coefficient at four Mach numbers.



(a) $C_N = 0.26$, $\delta_{aav} = 0.3^\circ$ down.



(b) $C_N = 0.52$, $\delta_{aav} = 4.2^\circ$ up.

Figure 9.- Wing-surface tuft behavior at a Mach number of 0.91 before and after the abrupt change in aileron floating angle.

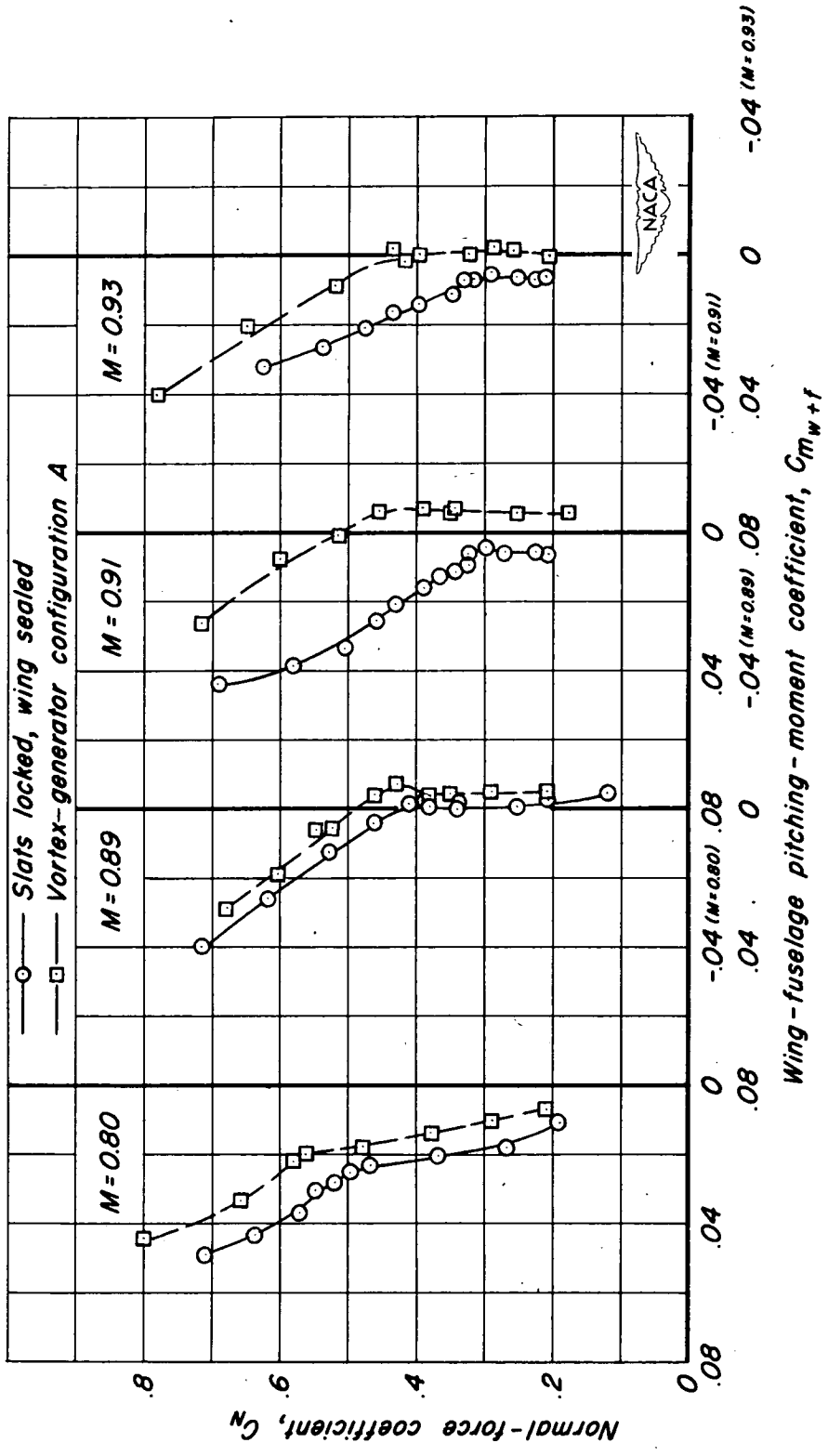
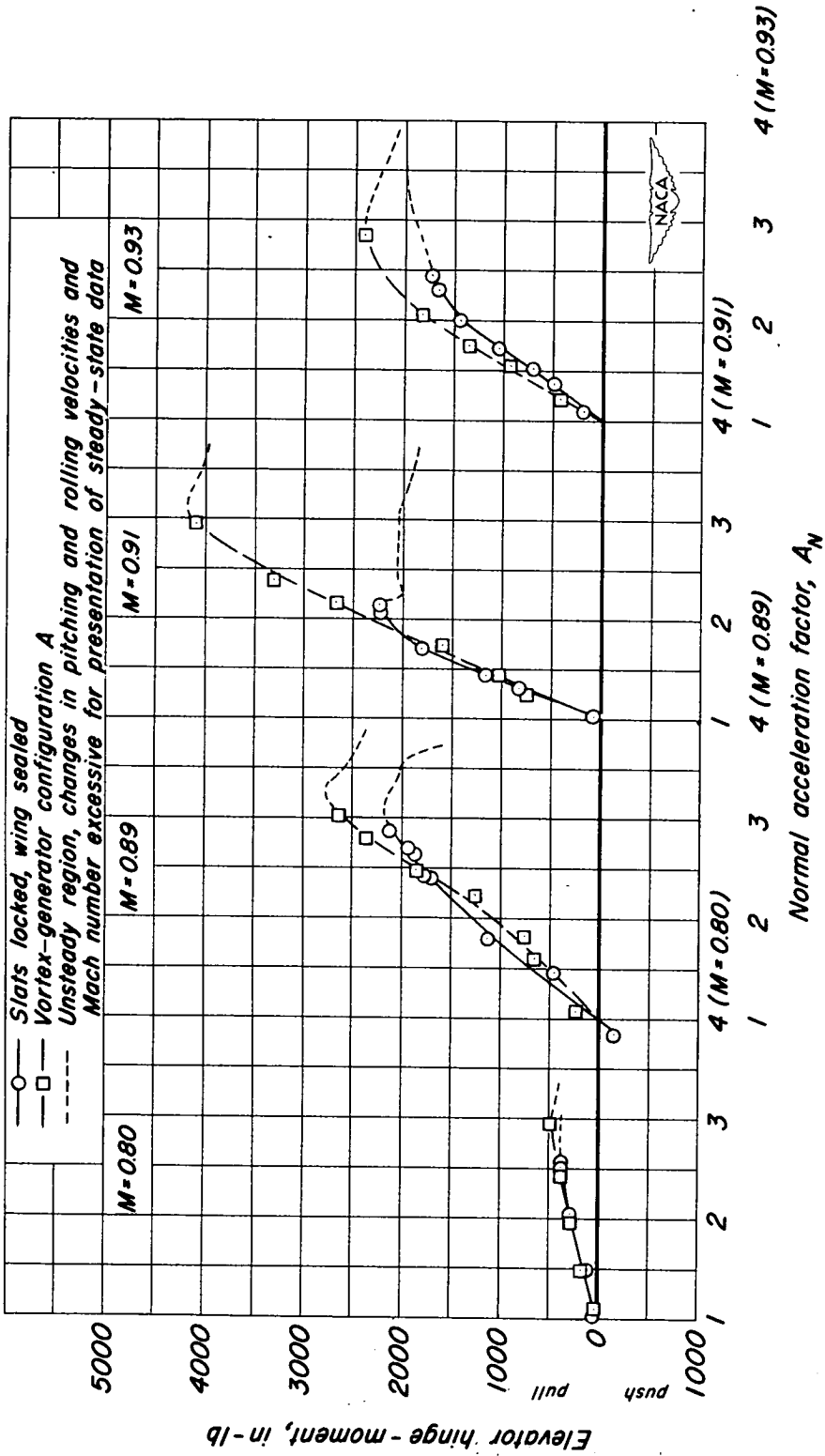
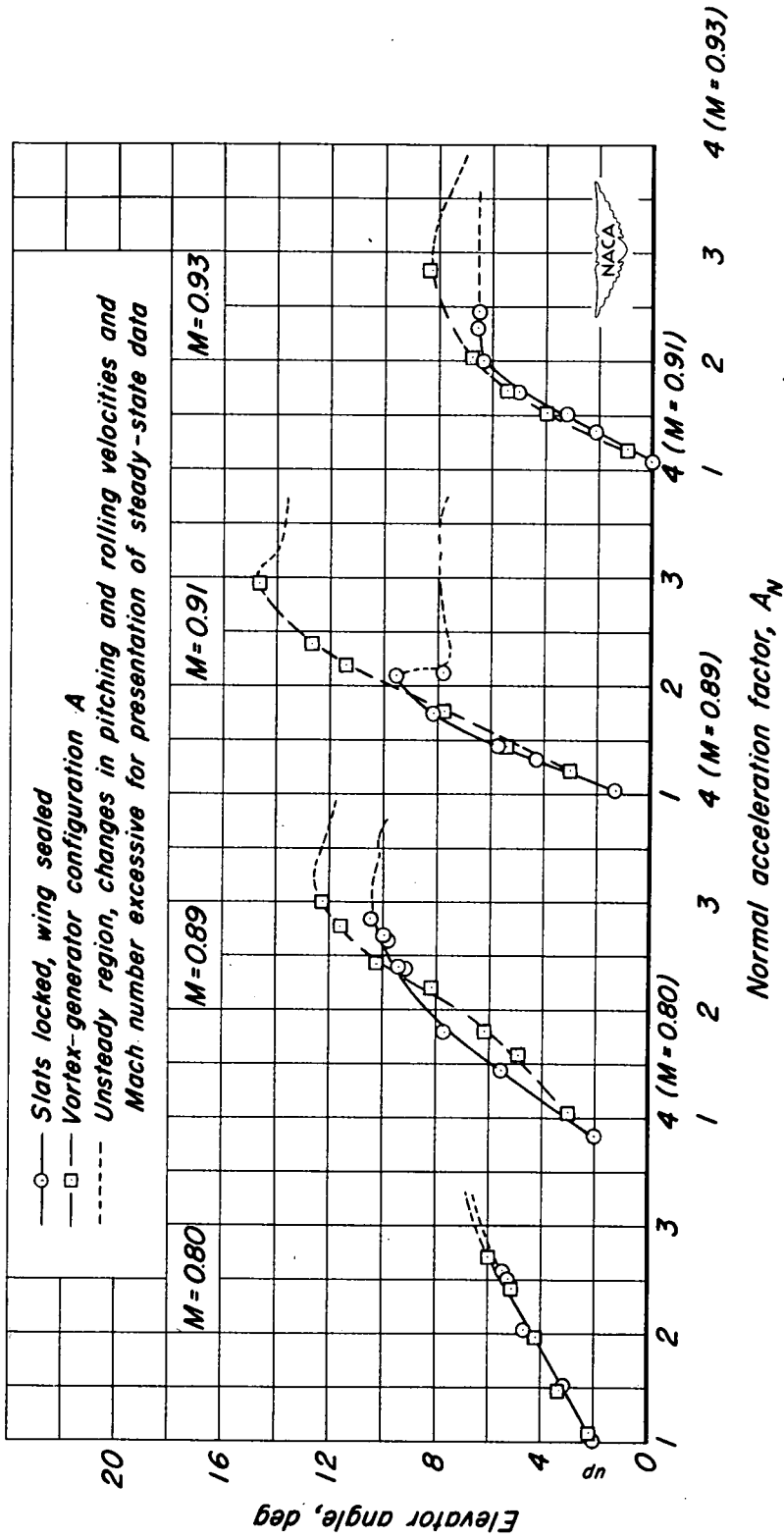

Figure 10.—The effect of vortex-generator configuration A on the pitching-moment characteristics of the wing-fuselage combination at four Mach numbers.



(a) Variation of elevator hinge-moment with normal acceleration factor.

Figure 11.- The effect of vortex generators on the longitudinal control characteristics in maneuvering flight at four Mach numbers at 35,000 feet altitude.



(b) Variation of elevator angle with normal acceleration factor.

Figure 11.- Concluded.

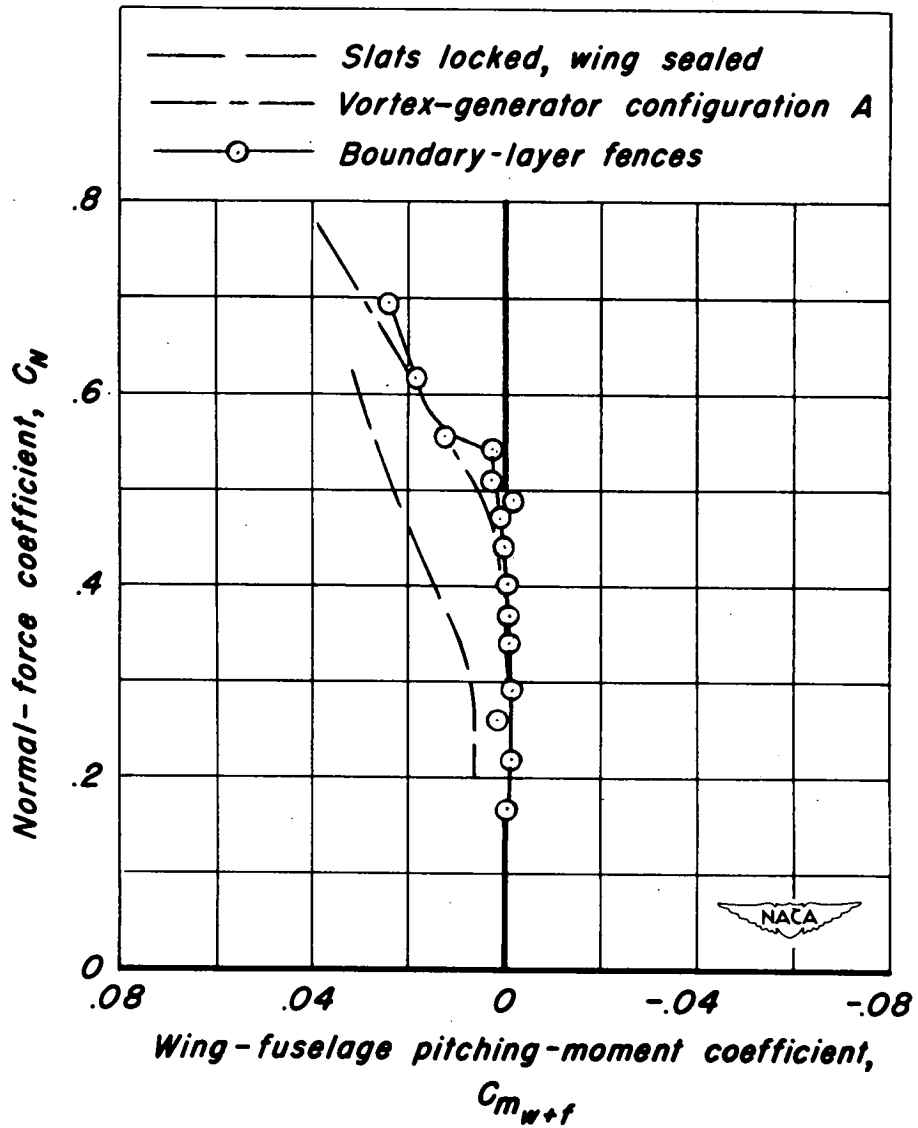

Figure 12.- A comparison of the effects of the vortex generators and the boundary-layer fences on the wing-fuselage pitching-moment characteristics at a Mach number of 0.93.

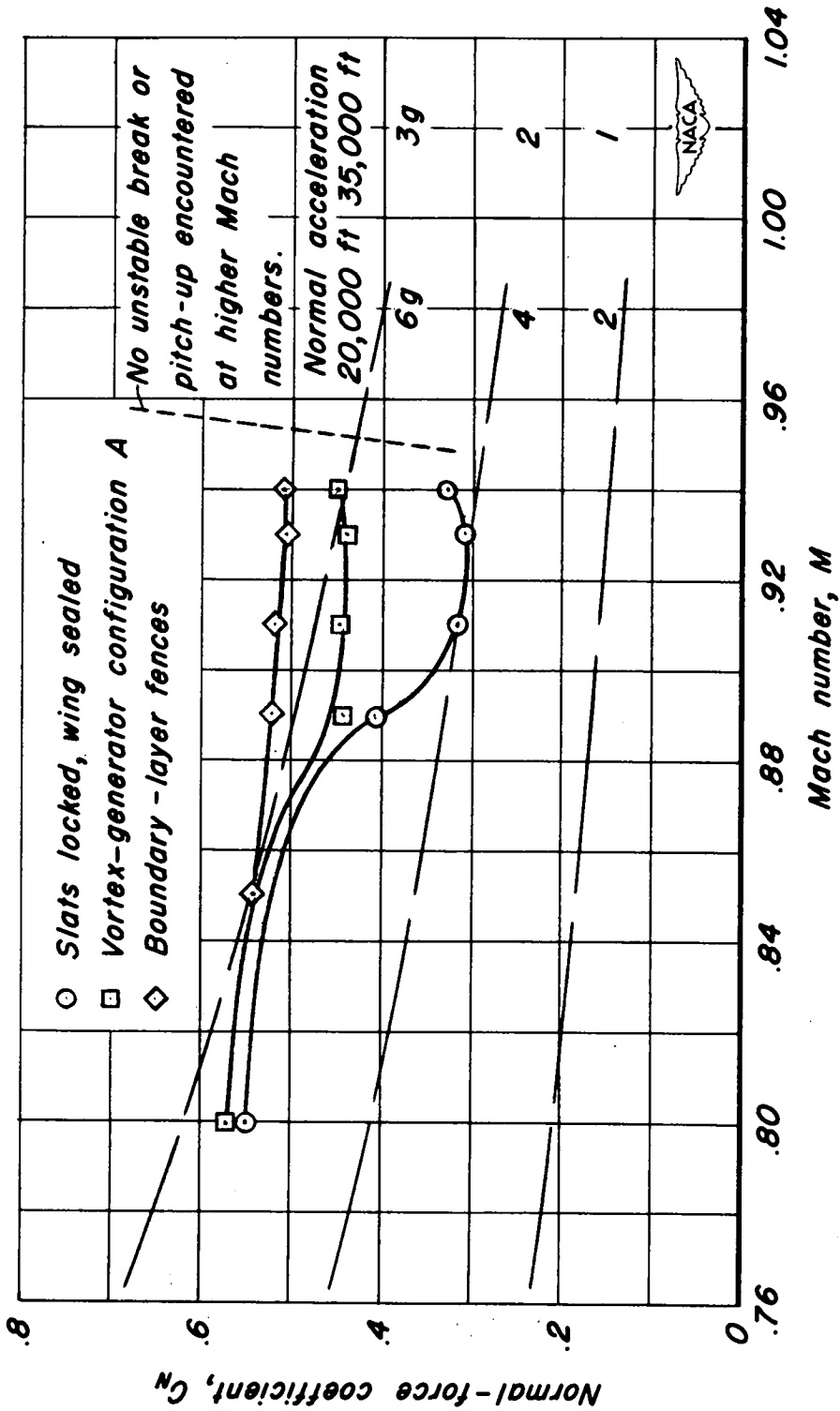

Figure 13.- The effect of Mach number on the normal-force coefficient for the change in stability of the wing-fuselage combination.

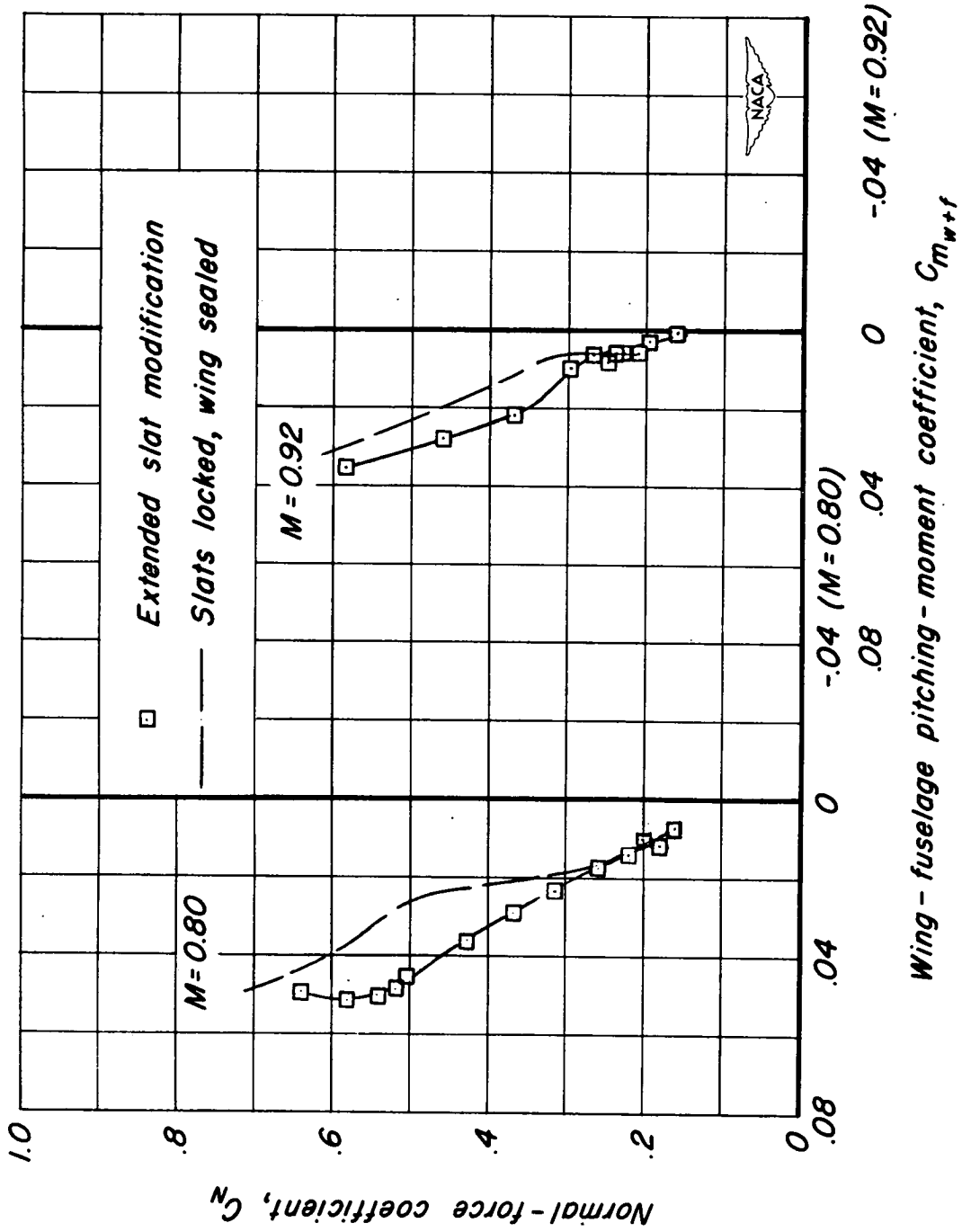

Figure 14.- The effect on the wing-fuselage pitching-moment characteristics of extending the outer two segments of the wing leading edge slats.

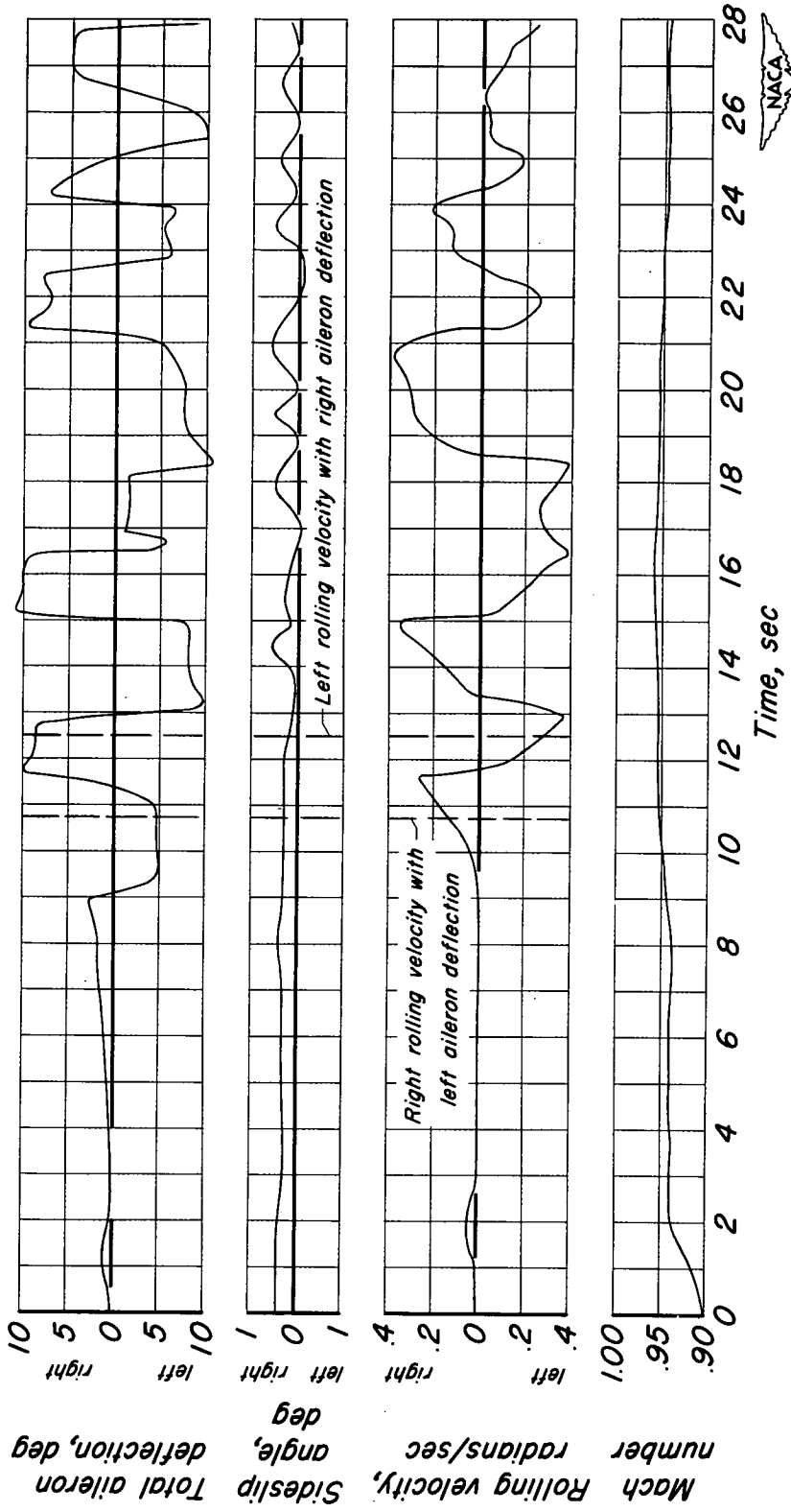
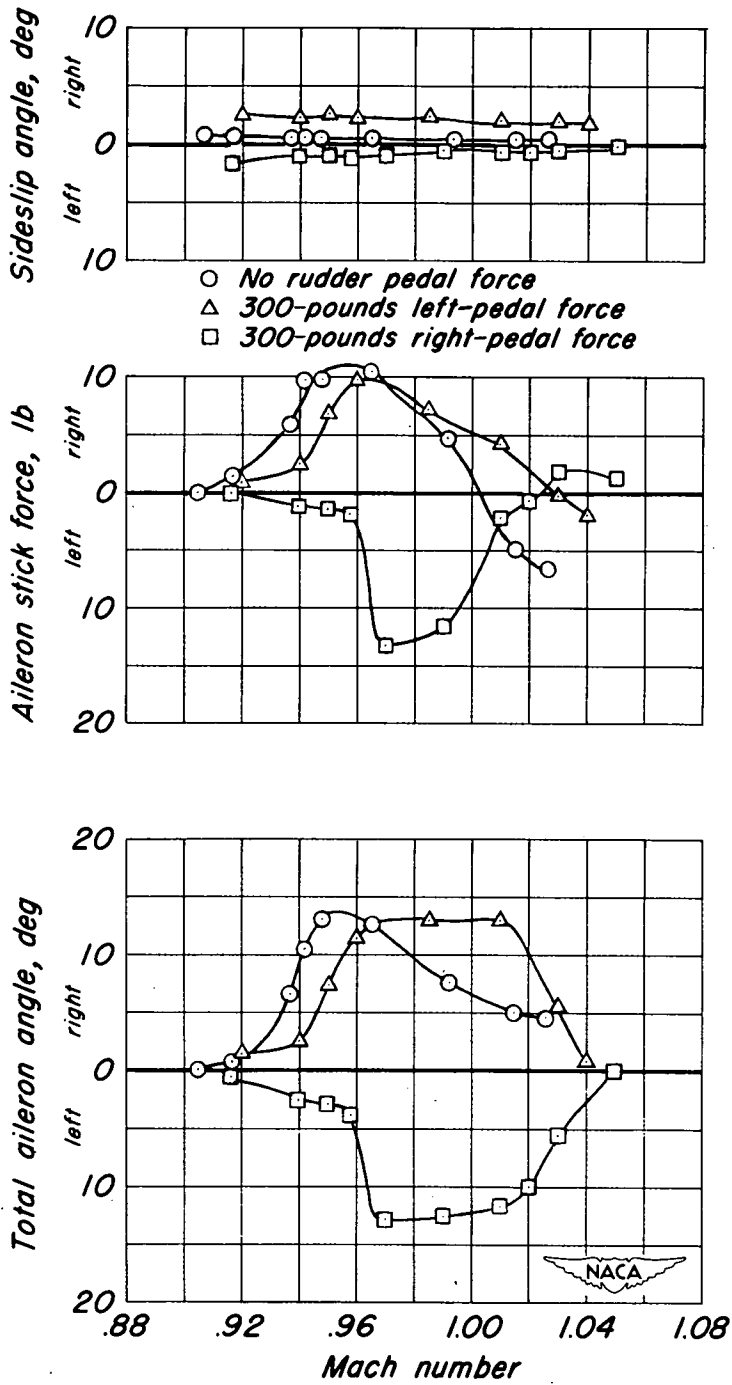
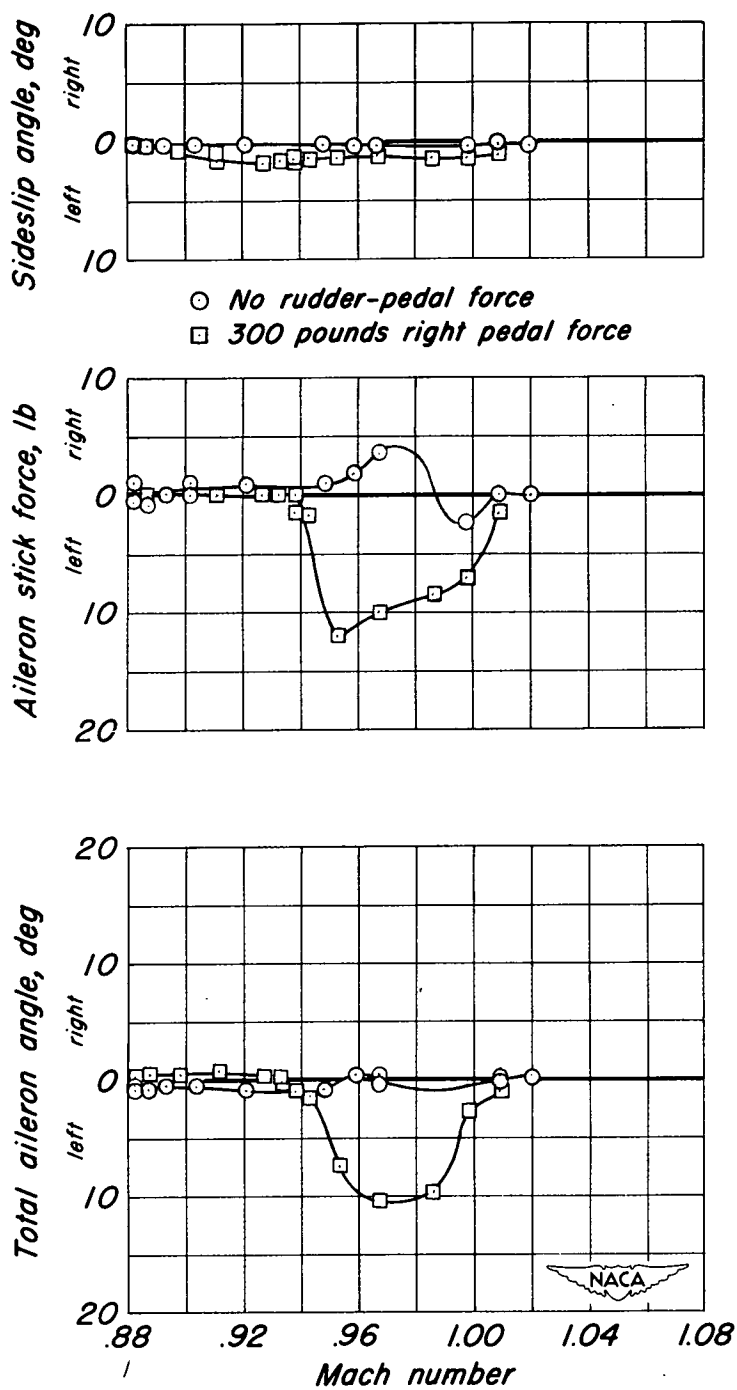

Figure 15. - Time history of reversal of aileron effectiveness, rudder fixed.



(a) Production airplane.

Figure 16.- The wing-dropping tendency at 35,000-foot altitude and three conditions of sideslip.



(b) Vortex-generator configuration A.

Figure 16.-Continued.

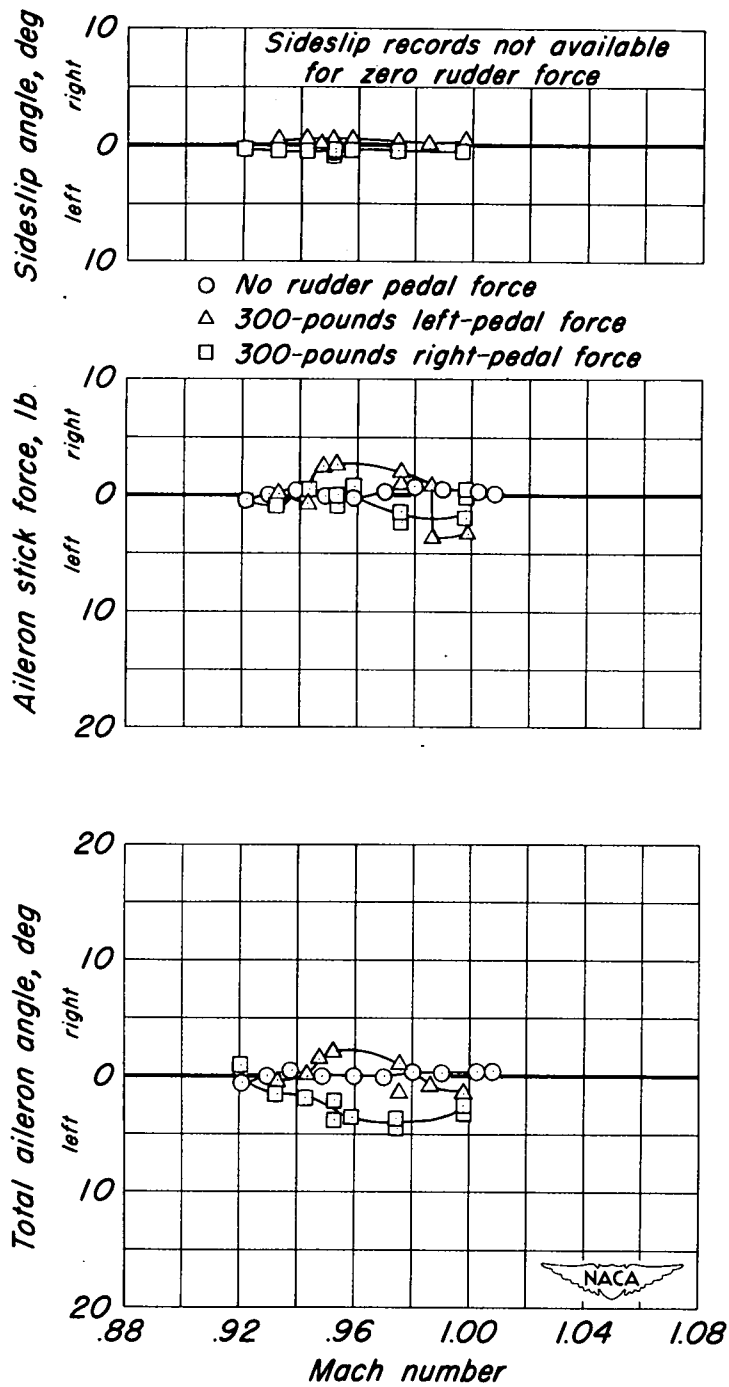

20

(c) Vortex-generator configuration B.

Figure 16.- Concluded.

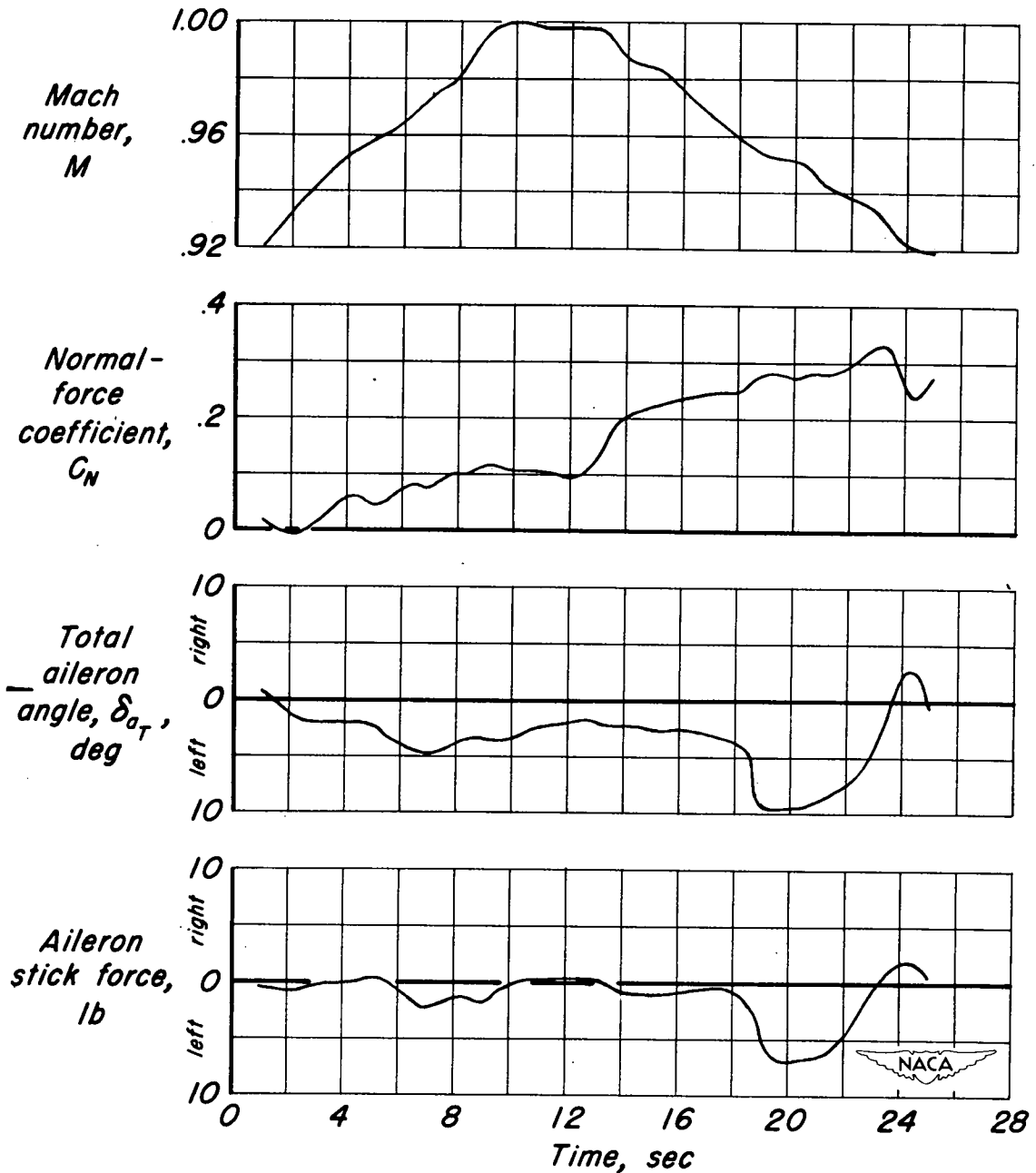

Figure 17.-Time history of wing-dropping tendency encountered in a pull-out at 35,000 feet altitude from a high-speed dive. Vortex-generator configuration B. 300 pounds right rudder pedal force, 0.2° to 0.8° left sideslip.

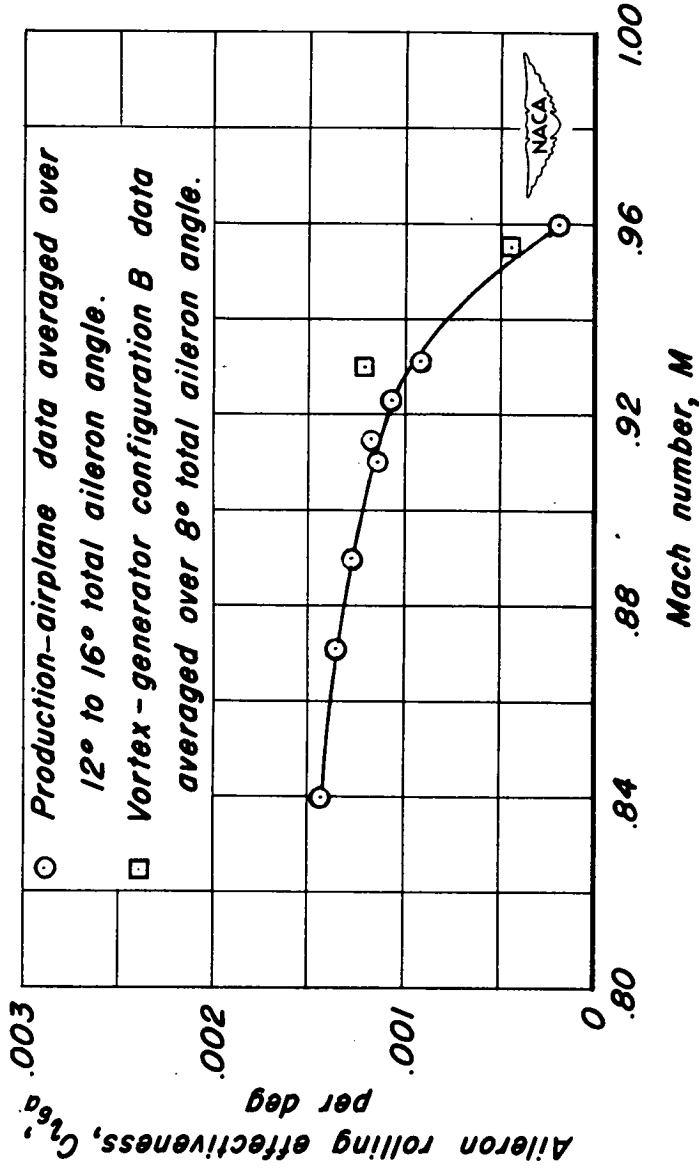

Figure 18.- The effect of vortex-generator configuration B on the aileron rolling effectiveness at two Mach numbers.

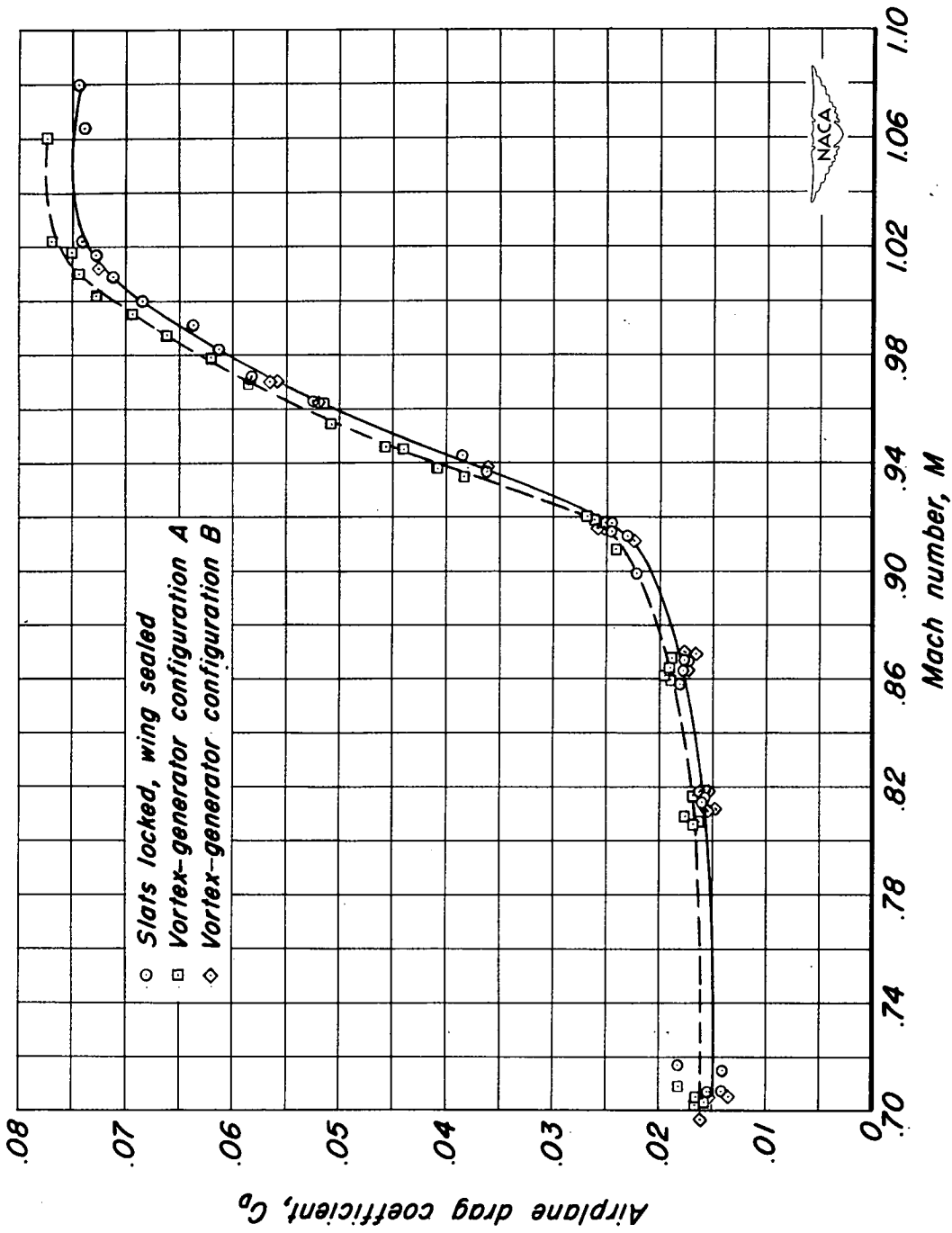

Figure 19.- The effect of vortex generators on the airplane drag coefficient at a lift coefficient of 0.15.

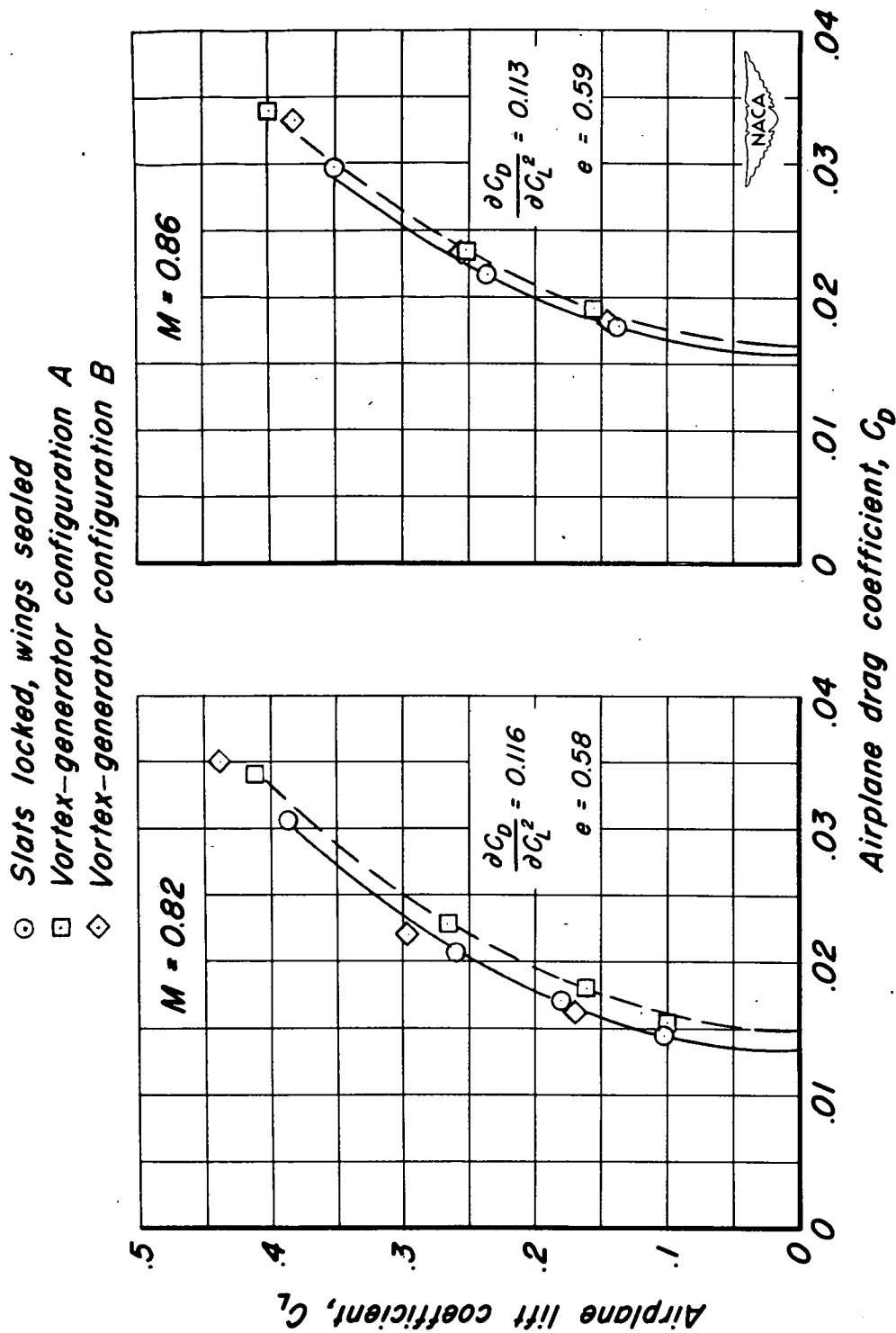

Figure 20.- The effect of the vortex generators on the variation of airplane drag coefficient with lift coefficient at two Mach numbers in the normal cruising range.