

~~CONFIDENTIAL~~
UNCLASSIFIED

C. 2
Copy ~~6~~
RM E51J24-21.B.

NACA RM E51J24

FEB 25 1952

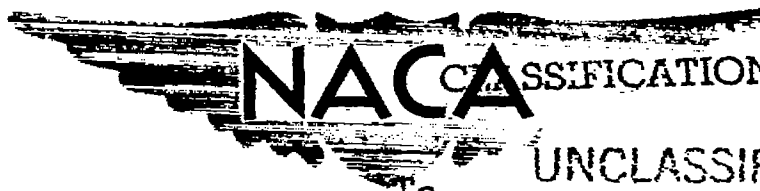

CLASSIFICATION CHANGED

To UNCLASSIFIED

RESEARCH MEMORANDUM

By authority of *ASTAR* Date *3-31-71*
V.9, No. 1 *llm*
8-1-71

EFFECT OF DESIGN CHANGES AND OPERATING CONDITIONS ON
COMBUSTION AND OPERATIONAL PERFORMANCE OF A
28-INCH DIAMETER RAM-JET ENGINE

By T. B. Shillito and Shigeo Nakanishi

Lewis Flight Propulsion Laboratory
Cleveland, Ohio

FOR REFERENCE

NOFORM

NOT TO BE TAKEN FROM THIS ROOM AVAILABLE FROM NASA TO U. S. GOV'T. AGENCIES
AND U. S. GOV'T. CONTRACTORS ONLY

CLASSIFIED DOCUMENT

This material contains information affecting the National Defense of the United States within the meaning of the espionage laws, Title 18, U.S.C., Secs. 793 and 794, the transmission or revelation of which in any manner to unauthorized person is prohibited by law.

NATIONAL ADVISORY COMMITTEE
FOR AERONAUTICS

WASHINGTON

February 13, 1952

~~CONFIDENTIAL~~
UNCLASSIFIED

NACA LIBRARY
LANGLEY AERONAUTICAL LABORATORY
Langley Field, Va.



NATIONAL ADVISORY COMMITTEE FOR AERONAUTICS

RESEARCH MEMORANDUM

EFFECT OF DESIGN CHANGES AND OPERATING CONDITIONS ON

COMBUSTION AND OPERATIONAL PERFORMANCE OF A
CLASSIFICATION CHANGED
 28-INCH DIAMETER RAM-JET ENGINE

By T. B. Shillito and Shigeo Nakanishi

UNCLASSIFIED

SUMMARY

By authority of *CSAR* Date *3-31-71*
V. 9, No. 1 *blm 8-4-71*

An investigation of the altitude performance of a 28-inch diameter ram-jet engine was conducted with a direct-connect system in an altitude test chamber at the NACA Lewis laboratory. Most of the investigation was for operation at a simulated Mach number of 2.0 at altitudes above the tropopause (250° F inlet temperature). Configurations investigated with normal heptane as the fuel included flame holders with blocked areas of 40.5 to 62.0 percent of the combustion-chamber area and gutter widths of 1.0 to 2.5 inches, exhaust nozzles with throat areas of 55 and 65 percent of the combustion-chamber area, and combustion chambers equipped with a center pilot burner. Runs were also made at inlet temperatures of 150° and 350° F and with Diesel fuel.

For the configurations without a pilot burner, the limits of combustion were significantly affected by fuel-air distribution and the width of the flame-holder gutters. When locally rich zones of fuel-air distribution were provided, the lean limits of combustion were improved, and when the gutter width was increased, both the lean and rich limits of combustion were improved. The effects of flame-holder geometry on combustion efficiency were small. When a pilot flame was provided, the lean limit of combustion was improved but the combustion efficiency was not improved. At over-all fuel-air ratios near stoichiometric, combustion efficiencies were nearly equal for combustion chambers equipped with the 55- and 65-percent exhaust nozzles, but the decrease in combustion efficiency with the decrease in fuel-air ratio was more pronounced for the 65-percent nozzle. Diesel fuel and normal heptane had about the same lean limits of combustion but lower combustion efficiencies were obtained with Diesel fuel. With the increase in inlet temperature, both the limits of combustion and combustion efficiency were improved.

INTRODUCTION

An investigation of the altitude performance of a 28-inch diameter ram-jet engine was conducted with a direct-connect system in a 10-foot

~~UNCLASSIFIED~~
UNCLASSIFIED

AVAILABLE FROM NASA TO U. S. GOV'T. AGENCIES
 AND U. S. GOV'T. CONTRACTORS ONLY

NOFORM

diameter altitude test chamber at the NACA Lewis laboratory. This engine is being developed by the Marquardt Aircraft Company for use in a Grumman Aircraft Engineering Corporation test vehicle as part of a Navy guided-missile project.

The missile is to be launched by a rocket booster and is to climb under its own power to a cruising altitude of 50,000 feet. The missile-control systems are designed to maintain a Mach number of 2.0 during the climb and cruise conditions. In order to satisfy the proposed missile-flight plan the engine must operate over an estimated range of fuel-air ratios from 0.03 to 0.06. The estimated range of operable fuel-air ratios was based upon the engine-thrust requirements dictated by the flight plan and anticipated combustion efficiencies varying in a uniform manner from 70 percent at a fuel-air ratio of 0.030 to a peak value of 94 percent at a fuel-air ratio of 0.052 and then decreasing to 91 percent at a fuel-air ratio of 0.060.

Investigations of engine performance at simulated altitudes from sea level to approximately 30,000 feet were conducted by the manufacturer. Investigations of engine performance in the high-altitude range of the flight plan were conducted at the NACA Lewis laboratory and included a range of simulated altitudes from 37,000 to over 55,000 feet. Results of these investigations are presented in references 1 to 4.

The purpose of this report is to summarize the principal results obtained in the NACA program and to show the effects of various operating conditions, geometrical variables, and type of fuel on combustion and engine performance. Information is presented to show the effects of fuel distribution on limits of combustion and combustion efficiency. The effects of flame-holder geometry on combustion performance are shown for gutter widths ranging from 1.0 to 2.5 inches and for blocked areas ranging from 40.5 to 62.0 percent of the combustion-chamber area. Operation of a configuration incorporating a pilot burner is compared with that for a typical configuration without a pilot burner. Performance of the engine with exhaust-nozzle throat areas of 55.0 and 65.0 percent of the combustion-chamber area is presented to show gross effects on engine performance as well as to illustrate the effects of combustion-chamber-inlet velocity on limits of combustion and combustion efficiency. Limits of combustion and combustion efficiency obtained with two fuels, normal heptane and high-speed Diesel fuel, are compared in order to illustrate the necessity of fitting the design of the combustion chamber to the volatility of the fuel being used. The effects of inlet temperature on combustion are shown over a range from 150° to 350° F.

APPARATUS

Description of Engine

A schematic diagram of the test engine is shown in figure 1. The inner body contours, including the supersonic diffuser cone, and the inside contours of the outer shell aft of the lip station correspond to those of the flight engine. The bellmouth convergent-divergent inlet nozzle surrounding the cone accelerated the inlet air from stagnation conditions in the test chamber to a Mach number of about 1.6 at the lip station, which is the Mach number expected at this station in the actual engine at a flight Mach number of 2.0. Four longerons spaced 90° apart and extending from about 4 inches aft of the lip station to the aft end of the inner body supported the inner body on the outer shell and formed a four-channel subsonic diffuser. The constant-area combustion chamber, which was water-jacketed, had an inside diameter of 28 inches. The fuel-injection systems, flame holders, pilot burner, exhaust nozzles, and combustion-chamber length are described in the following sections.

Combustion-Chamber Configurations

Configuration 1: Fixed-orifice fuel nozzles. - The essential features of configuration 1 are shown in figure 2 and are described in detail in reference 1. Fuel was injected at a station approximately 40 inches upstream of the aft end of the inner body through commercially available flat-spray fuel nozzles. The fuel nozzles, which were directed both upstream and downstream were mounted in four circular-arc manifold segments. The segmented construction of the fuel manifolds was necessary because of the presence of the inner-body support longerons. The radial location of the fuel nozzles with respect to the engine center line was 12.3 inches. Radii of the outer shell and inner body at the fuel injection station were 14.0 and approximately 7.9 inches, respectively.

The flame holder, which is shown in figure 2(b), was made of four annular-ring V-type gutters 1 inch wide at the open end and mounted at the aft end of the inner body. The gutter rings were longitudinally staggered and were interconnected by radial plates mounted parallel to the direction of flow and by radial V-gutter struts. The flame holder incorporated flight-engine type cylindrical ignition flare cases and also a separate spark-plug ignitor box provided expressly for starts during the altitude-test-chamber investigation. The projected blocked area of the flame holder was 42 percent of the cross-sectional area of the combustion chamber.

The combustion chamber was 46 inches long. The convergent-divergent exhaust nozzle had a throat area which was 55 percent of the combustion-chamber area.

Configuration 2: Spring-loaded fuel nozzles. - The flame holder, combustion-chamber length, and exit nozzle for configuration 2 were the same as for configuration 1. A double-manifold fuel-injection system was used and is illustrated in figure 3. One set of four manifold segments was located at the same longitudinal station as for the fuel manifold of configuration 1 and an additional set of four segments was located approximately 10 inches downstream. Both manifolds were equipped with pintle-type spring-loaded fuel nozzles directed upstream only. Details of these nozzles are given in reference 1. The radial locations of the fuel nozzles in the upstream and downstream manifolds were 10.0 and 12.3 inches, respectively.

Configuration 3: Flame-holder geometry variation. - The fuel-injection system, combustion-chamber length, and exit nozzle for configuration 3 were the same as for configuration 2. Ten different flame holders were used and are designated configurations 3a to 3j. The general type of construction of these flame holders was the same as for the flame holder used for configurations 1 and 2. Principal design features of these flame holders are given in the following table:

Configuration	Gutter width (in.)	Blocked area (percent)	Number of annular rings
3a ^a	1.00	42.0	4
3b	1.00	55.0	6
3c	2.00	45.0	2
3d	1.50	40.5	3
3e	2.00	60.0	3
3f	1.20	58.0	5
3g	1.38	62.0	5
3h	1.00	48.7	5
3i	1.40	55.0	4
3j	2.50	60.0	2

^aIdentical to configuration 2.

Further details of the construction of these flame holders may be found in reference 2. The structural requirements involved in the construction of these flame holders made it difficult to control precisely the blocked area resulting from the use of a given gutter width. The characteristics of each flame holder were plotted on coordinates of gutter width and blocked area as shown in figure 4. In an attempt to give

families of varying gutter width at constant blocked area or of varying blocked area at constant gutter width, the points representing the flame holders were arbitrarily grouped by cross-hatched bands.

Configuration 4: Pilot burner. - A schematic diagram of configuration 4 is shown in figure 5. The aft end of the inner body for this configuration, instead of tapering to a point as for configurations 1 to 3, terminated bluntly for accommodation of a can-type pilot burner. The flame holders were mounted in the plane of the pilot-burner discharge. A disassembled view of the aft end of the inner body, pilot burner, and flame holder is shown in figure 6. The pilot burner consisted of a swirl plate and a basket-type skirt. The pilot-burner skirt was notched in four places on the downstream end to receive small radial gutter elements which interconnected the pilot burner and flame holder.

The construction of the flame holders used with the pilot burner was similar to the construction of the flame holders for configurations 1 to 3. The flame holder for configuration 4a had four 1.38-inch longitudinally staggered annular-V gutters and a blocked area of 54.0 percent of the combustion-chamber area. The flame holder for configuration 4b had two 2.00-inch gutters and a blocked area of 45.0 percent.

Fuel was injected at a station approximately 32 inches upstream of the flame holder through spring-loaded fuel nozzles spraying upstream from two concentric manifolds (fig. 5). Each manifold was composed of four circular arcs as described for configuration 1 to 3. Radial locations of the inner and outer ring of fuel nozzles were 9.0 and 12.3 inches, respectively. Radii of the inner body and outer shell in the plane of the fuel-nozzle discharge were 7.3 and 14.0 inches, respectively.

The exit nozzle was the same as for configurations 1 to 3. The length of the combustion chamber was 57 inches. Further details of the fuel-injection system, pilot burner, and flame holders may be found in reference 3.

Configuration 5: Increased exhaust-nozzle throat area. - The fuel-injection system, pilot burner, flame holder, and combustion-chamber length were the same for configuration 5 as for configuration 4b. The exhaust-nozzle throat area was 65 percent of the combustion-chamber area. A complete description of configuration 5 may be found in reference 4.

Instrumentation

Detailed descriptions of the instrumentation for the various combustion-chamber configurations described may be found in the

appropriate references 1 to 4. General descriptions of location and type of measurement in the engine which are pertinent to this report are as follows (station numbers correspond to those on fig. 1):

Location	Station	Type of measurement
Bellmouth inlet	0	Total pressure and temperature
Combustion-chamber inlet	2	Total and static pressure
Combustion-chamber exit	4	Total pressure
Exhaust-nozzle throat	5	Wall- and stream-static pressure

Fuel flow was measured with a calibrated adjustable-orifice meter and air flow was determined from a calibration of the choked-bellmouth-inlet nozzle of the engine.

Installation in Altitude Chamber

A schematic diagram of the engine mounted in the altitude test chamber is shown in figure 7. A forward baffle attached to the engine by means of a flexible seal isolated the inlet-air supply from the low-pressure compartment provided for the engine exhaust. A rear baffle surrounding the engine near the exhaust nozzle prevented recirculation of the hot exhaust gases around the engine. Other details of the installation are given in reference 1.

PROCEDURE

Most of the investigation reported herein was for a simulated flight Mach number of 2.0 at NACA standard altitudes above the tropopause. This required preheating the inlet air to 250° F from a normal supply temperature of about 80° F, which was accomplished by mixing the products of combustion from an air heater with the inlet-air supply. The effect of the combustion-heater contamination of the charge air on engine performance is not known but probably is small.

With the heater in operation, the engine was started and the exhaust pressure was then reduced to a value below that required to choke the exhaust nozzle. The exhaust nozzle remained choked for all runs, as is the case for the flight engine, thereby making flow conditions in the combustion chamber independent of the facility exhaust pressure.

In order to simulate a specific altitude for the steady-burning runs at an inlet temperature of 250° F the stagnation pressure at the bellmouth inlet was set to a value corresponding to that behind the oblique shock off the supersonic-diffuser cone of the flight engine.

The engine air flow was determined by the bellmouth-inlet pressure setting and, for the runs at an inlet temperature of 250° F, corresponded to the air flow for supercritical operation of the actual engine at a flight Mach number of 2.0; there were no provisions on the test engine for subcritical air flow spillover simulation. The range of simulated altitudes covered in the preceding manner during the investigation was from 37,000 to over 55,000 feet. Specific altitudes investigated for any particular configuration may be found in references 1 to 4.

Runs were made at inlet temperatures of 150°, 250°, and 350° F with configuration 5. Because the geometry of the bellmouth inlet was set to simulate operation at a flight Mach number of 2.0, rigorous simulation of operating Mach numbers and altitudes corresponding to inlet temperatures of 150° and 350° F was not possible. Consequently, the air flows for 150° and 350° F were set to correspond with those at 250° F to provide similar average conditions at the combustion-chamber inlet for all three inlet temperatures.

With the simulated altitude or air flow set, the fuel-air ratio was varied in small increments and data were taken at stabilized-burning conditions. The fuel-air ratio range covered was generally from lean blow-out to rich blow-out or, if rich blow-out did not occur, to some fuel-air ratio above 0.07. Blow-out was detected by the change in sound level, observation of blow-out through a periscope viewing the discharge of the engine, and automatic fuel-flow cut-off through action of a photoelectric flame-sensing element attached to the combustion chamber.

For the single-manifold fuel-injection system of configuration 1, all runs were made with equal fuel pressures applied to all nozzles. For the double-manifold fuel-injection systems of configurations 2 to 5, three different methods of fuel injection were used:

(1) Uniform injection: The injection is at equal fuel pressures through all nozzles in both inner and outer manifolds. All of the configurations 2 to 5 were operated with uniform injection.

(2) Quadrant injection: The injection is at equal fuel pressures through nozzles in inner- and outer-manifold segments located in only two diametrically opposite quadrants. Quadrant injection data were obtained only with configuration 2. Quadrant injection was used in order to improve the lean limits of combustion (over those obtainable with uniform injection) by creation of locally rich fuel-air ratios at low over-all fuel-air ratios.

(3) Annular injection: The injection is at equal fuel pressures through nozzles in inner manifold only. Annular injection was used with some of the more promising configurations in order to improve the

lean limits of combustion by local fuel-air enrichment and was used in preference to quadrant injection because the predominant sheltered areas provided by the flame holders were annular rings.

Performance of all the configurations was investigated with commercial-grade normal heptane. In addition, several runs were made with configuration 5 using high-speed Diesel fuel (U.S. Army Specification 2-102C, Amendment 3). Comparative properties of these two fuels may be found in reference 4.

Combustion efficiencies were calculated by the methods outlined in detail in references 1 and 2. The methods used to calculate combustion efficiency involved the assumptions that ideal one-dimensional choked flow existed in the plane of the exhaust-nozzle throat and that the gas temperature was uniform across the stream. (The symbols and station locations used throughout the report are defined in the appendix.)

DISCUSSION OF RESULTS

For the data presented in this report fuel-air ratio, combustion-chamber-inlet Mach number and, at constant simulated altitude, combustion-chamber-inlet and -exit pressures were functionally related for a given configuration. The interrelation of these variables resulted from the conditions necessary for continuity of flow through the choked exhaust nozzle. For the configurations employing the 55-percent exhaust nozzle (configurations 1 to 4) the combustion-chamber-inlet Mach number generally varied from approximately 0.23 at a fuel-air ratio of 0.03 to a value of 0.14 at fuel-air ratios of 0.06 and greater. At a simulated altitude of 50,000 feet and a fuel-air ratio of 0.07 the combustion-chamber-exit total pressure was approximately 1600 pounds per square foot and decreased to approximately 1000 pounds per square foot at a fuel-air ratio of 0.03. At a given fuel-air ratio the combustion-chamber-exit pressure was approximately proportional to the static pressure at the altitude simulated; departures from this proportionality resulted from variations of combustion efficiency at constant fuel-air ratio. Specific conditions of operation for the configurations discussed in the following sections may be found in references 1 to 4.

Performance of Configuration 1

The altitude limits of combustion, over-all exhaust-nozzle pressure ratio, and combustion efficiency obtained with configuration 1 are shown in figure 8 as a function of fuel-air ratio.

The limits of combustion (fig. 8(a)) are composed of two parts, a lean limit and a rich limit. Each limit defines the highest altitude

for which stable combustion could be obtained at a given fuel-air ratio, and the area bounded by the curves represents the range of operable fuel-air ratios. Above a simulated altitude of 40,000 feet the operable range of fuel-air ratios was narrow and at a simulated altitude of 50,000 feet, the cruising altitude of the missile, operation could not be obtained at any fuel-air ratio.

The ratio of combustion-chamber-exit total pressure to simulated-altitude static pressure (exhaust-nozzle pressure ratio) is shown in figure 8(b). This pressure ratio is a measure of the effective jet thrust and at a given altitude increased with fuel-air ratio continuously to the rich limit of combustion. At a given fuel-air ratio, the pressure ratio decreased slightly with increasing altitude; this decrease is a reflection of decreasing combustion efficiency with increasing altitude.

At a given simulated altitude, combustion efficiency (fig. 8(c)) first increased with fuel-air ratio until a peak value was reached at a fuel-air ratio of approximately 0.047 and then decreased with further increases in fuel-air ratio. Peak combustion-efficiency values of 88, 82, and 77 percent were obtained at simulated altitudes of 37,000, 40,000, and 45,000 feet, respectively. At a constant fuel-air ratio combustion efficiency decreased with increasing altitude, primarily as a result of the decreasing level of pressure at which combustion occurred.

Configuration 1 was obviously unsatisfactory because of the very limited range of operation above an altitude of 40,000 feet. Improvements in combustion efficiency were also desired. Two methods were used in an effort to improve the limits of combustion and combustion efficiency: (1) changing the fuel distribution, and (2) changing the flame-holder geometry.

Effect of Fuel Distribution

In order to insure stable combustion, a fuel-air ratio near stoichiometric must be provided in the vicinity of the sheltered regions of the flame holder. A uniform distribution of fuel at over-all fuel-air ratios near stoichiometric and localized regions of near-stoichiometric mixtures at lean over-all fuel-air ratios are required to maintain conditions satisfactory for stable combustion. The double-manifold fuel-injection system shown schematically in figure 9(a) was used to improve the fuel-air distribution over the distribution obtained with configuration 1. Photographs of combustion (figs. 9(b) to 9(d)), taken through the periscope viewing the discharge of the engine, show the location of burning for the types of injection used with the double-manifold system. With uniform injection (fig. 9(b))

the flame intensity, as shown by the light and dark areas, did not vary greatly across the combustion chamber. The light areas shown in figures 9(c) and 9(d) illustrate clearly that with quadrant injection most of the combustion occurred in the zones following the quadrants in which fuel was injected and that with annular injection combustion was confined primarily to a core in the center of the combustion chamber.

Comparison of performance with uniform and quadrant injection. - The limits of combustion, over-all exhaust-nozzle pressure ratio, and combustion efficiency obtained with configuration 2 are shown in figure 10. Both uniform and quadrant fuel injection were used. The limits of combustion for uniform injection (fig. 10(a)) were shifted to a region of fuel-air ratios richer than the ratios obtained with configuration 1. For example, at a simulated altitude of 40,000 feet, lean blow-out occurred at a fuel-air ratio of 0.044 for configuration 2 compared with 0.035 for configuration 1. This shift of limits to higher fuel-air ratios is a logical result of the more uniform distribution of fuel with the double-manifold fuel-injection system which, for any over-all fuel-air ratio, gave lower local fuel-air ratios than those obtained with the single-manifold system.

The use of quadrant injection resulted in very pronounced improvements in the lean limits of combustion. For example, between altitudes of 40,000 and 45,000 feet the lean limit of combustion was reduced from a fuel-air ratio of approximately 0.045 for uniform injection to 0.030 for quadrant injection. Concentration of the fuel in only two of the four quadrants maintained high local fuel-air ratios and improved flame stabilization at low over-all fuel-air ratios.

The behavior of the over-all exhaust-nozzle pressure ratio for configuration 2 (fig. 10(b)) was similar to the behavior obtained for configuration 1. Higher combustion efficiencies obtained with configuration 2, however, resulted in exhaust-nozzle pressure ratios which were high enough so that the supersonic diffuser could be expected to operate critically (that is, with a normal shock at the lip station). The diffuser critical points, which are shown in figure 10(b) and subsequent figures, were estimated on the basis of an oblique shock generated by a 20° half-angle cone, an ideal normal shock at the average inlet Mach number of the flight engine (at a flight Mach number of 2.0), a total pressure ratio of 0.93 in the subsonic diffuser, and the combustion-chamber pressure ratios obtained during operation in the altitude test chamber. When the fuel-air ratio is increased above the critical values in the actual flight engine, either slightly increasing or some degree of decreasing exhaust-nozzle pressure ratios would result, depending on the pressure-recovery characteristics of the supersonic diffuser when operating subcritically.

Peak values of combustion efficiency at comparable simulated altitudes were higher and occurred at higher fuel-air ratios for configuration 2 with uniform injection than the peak values of combustion

2587

efficiency obtained with configuration 1. At 40,000 feet the combustion efficiency for uniform injection was 97 percent at a fuel-air ratio of 0.054 (fig. 10(c)) and decreased sharply to a value of 83 percent at a fuel-air ratio of 0.044. Combustion efficiencies obtained with quadrant injection blended with a general trend of sharply decreasing combustion efficiency with decreasing fuel-air ratio. This trend was apparent in the performance obtained for both configurations 1 and 2.

Comparison of limits of combustion for quadrant and annular injection. - Improvements in the lean limit of combustion obtained with both quadrant and annular injection are shown in figure 11 for configuration 3b. Although the data obtained were limited the results show that at an altitude of 45,000 feet the improvement in the lean limit of combustion was about the same for both quadrant and annular injection.

Because the limits of combustion for configuration 3b were similar for both quadrant and annular injection, annular injection was used for all subsequent configurations. Annular injection was felt to be a more logical method because the predominant sheltered areas provided by the flame holders were annular rings.

As has been shown in the previous sections, fuel distribution had a very important effect on the lean limits of combustion. The creation of localized zones of near-stoichiometric fuel-air ratio resulted in pronounced improvements over the lean limits of combustion obtained with uniform injection. The maximum combustion efficiencies obtained with rich zone injection were lower and occurred at lower over-all fuel-air ratios than those obtained with uniform injection. The method of injection, however, was not entirely responsible for the lower combustion efficiencies obtained with rich-zone injection inasmuch as the operating conditions were less favorable for combustion at the lower over-all fuel-air ratios where rich-zone injection was used.

Effect of Flame-Holder Geometry

Flame-holder geometry was varied as an alternative method of improving the limits of combustion and combustion efficiency. Configurations 3a to 3j were used in the investigation of the effects of flame-holder geometry.

Effect of gutter width on limits of combustion. - The theory of burning in the wake of bluff bodies (reference 5) states that continuous ignition occurs as a result of transfer of hot gases from recirculating eddies or vortices immediately downstream of the bluff body into the boundary region of relatively cold fuel-air mixtures. The temperature of the boundary mixture increases as the flow proceeds downstream until the appropriate ignition temperature is reached. From a balance

between the heat supply rate required for ignition in the boundary zone and the rate of heat flow from the eddy region, it can be shown that for a given fuel-air distribution, inlet-air pressure, and inlet-air temperature the fuel-air ratio at which blow-out occurs is a function of the width of the bluff body or gutter and the mixture velocity past the body.

In the investigation of the effects of flame-holder geometry, the throat area of the choked exhaust nozzle was not varied and the inlet-air temperature was held constant so that the velocity past the flame holder was a function only of the gutter width and blocked area for data obtained at constant fuel-air ratio and pressure. The effects of gutter width and blocked area were manifest only as attendant effects on combustion efficiency, which are subsequently shown to be small, and an undefinable effect of decreased flow area in the case of blocked area. Thus, in order to adapt the previously discussed theory to the data obtained, the fuel-air ratio at which blow-out occurred was plotted against flame-holder gutter width. The results obtained are shown in figure 12.

The three curves shown in figure 12 define the rich and lean limits of combustion with uniform injection and the lean limits of combustion for annular injection, all for a combustion-chamber exit pressure of 1400 pounds per square foot absolute. Each of the points defining a given curve is for a different flame holder, its gutter width being the geometrical variable of interest. The fuel-air ratio defining the limits of combustion increased for uniform rich blow-out and decreased for uniform and annular lean blow-out as gutter width increased. Thus, the improvement of the operable range of fuel-air ratios with increasing gutter width is in apparent qualitative agreement with the previously discussed theory. A combination of wide gutter width and locally rich fuel-air ratios yielded the best lean limits of combustion.

Effect of blocked area and gutter width on combustion efficiency.

The effect of flame-holder blocked area on combustion efficiency for a fuel-air ratio of 0.05 and a combustion-chamber-exit pressure of 1800 pounds per square foot absolute is shown in figure 13. Three curves are shown and are for families of flame holders with gutter widths of 1.00, 1.38 to 1.50, and 2.00 inches. These curves were obtained by cross-plotting from faired curves for each flame holder involved. Only two flame holders with 2.00-inch gutter width were investigated and the curve shown for this family of flame holders was drawn to conform to the trend for the 1.38- to 1.50-inch gutter-width family. The effect of blocked area on combustion efficiency was small for all three families of flame holders; two of the constant-gutter-width families indicate a slight increase in combustion efficiency and the third a slight decrease in combustion efficiency with increasing blocked area.

The effect of flame-holder gutter width on combustion efficiency for a fuel-air ratio of 0.05 and a combustion-chamber-exit pressure of 1800 pounds per square foot absolute is shown in figure 14. Curves are shown for two families of flame holders, one with blocked areas from 60.0 to 62.0 percent and the other with blocked areas from 40.5 to 45.0 percent. The effect of gutter width on combustion efficiency for both of the constant blocked-area flame-holder families was small.

The effects of flame-holder blocked area and gutter width on combustion efficiency, which are shown in figures 13 and 14, are typical of the results obtained and presented in more detail in reference 2. The effects of both geometrical variables were relatively small over the range of combustion-chamber operating conditions for which comparisons were possible. An additional variable which could not be isolated as flame-holder geometry varied was the distribution of blocked area relative to the fixed fuel-air distribution pattern. Inasmuch as the over-all changes in combustion efficiency were small for relatively large changes in geometry and the trends did not follow an entirely consistent pattern (see reference 2), it is probable that the distribution of blocked-area had as important an effect on combustion efficiency as either blocked area or gutter width.

Effect of Pilot Flame

Past experience with combustion chambers for tail-pipe-burner and ram-jet application has shown that the presence of a pilot flame helps to stabilize combustion at low fuel-air ratios. Investigation of the pilot-burner configurations was directed toward improvement of the range of operation obtained with configurations without a pilot burner.

Comparative performance of configurations with and without pilot burner. - A comparison of the altitude limits of combustion and the over-all exhaust-nozzle pressure ratio is shown in figure 15 for configurations 4a and 3j. Of the pilot-burner configurations investigated, configuration 4a had the best lean limits of combustion. Configuration 3j was chosen for the comparison because it had the best lean limits of combustion for all the configurations without pilot burner.

The lean limits of combustion obtained with annular injection are shown in figure 15(a) for configurations 4a and 3j. The lean limit obtained with the pilot-burner configuration was better than the lean limit obtained with the configuration without pilot burner by approximately 0.01 in fuel-air ratio over the range of altitudes for which a comparison was possible. This lean limit improvement obtained by providing a pilot flame is particularly significant because configuration 3j was, with respect to combustion limits, the best configuration found in the investigation of flame-holder geometry.

A comparison of over-all exhaust-nozzle pressure ratios for the configurations with and without pilot burner at a simulated altitude of 50,000 feet is shown in figure 15(b). The over-all exhaust-nozzle pressure ratio at the critical-diffuser point was 6.0 for both configurations. At over-all exhaust-nozzle pressure ratios below the critical value, the fuel-air ratio with uniform injection was higher for the configuration with a pilot burner than for the configuration without a pilot burner, and with annular injection the fuel-air ratio was lower for the configuration with a pilot burner than for the configuration without a pilot burner. Thus, combustion efficiencies for the configuration with a pilot burner were lower with uniform injection and somewhat higher with annular injection than those for the configuration without a pilot burner at all fuel-air ratios below the critical point. The minimum operable exhaust-nozzle pressure ratios, which occurred at the fuel-air ratios corresponding to the lean limits of combustion, were 3.3 and 3.6 for the configurations with and without a pilot burner, respectively.

Effect of Exhaust-Nozzle Geometry

Performance of the engine equipped with an exhaust nozzle having a throat area of 65 percent of the combustion-chamber area was determined because the engine manufacturer's estimates of thrust based upon use of a 55-percent exhaust nozzle indicated that a marginal condition might exist immediately following termination of the rocket boost. The larger exhaust-nozzle throat area gave higher thrust than the 55-percent nozzle for a given exhaust-nozzle pressure ratio, but at the same time imposed a higher velocity and a lower pressure on the combustion chamber at a given fuel-air ratio and simulated altitude.

Comparison of jet-thrust coefficients for 55- and 65-percent exhaust nozzles. - Jet-thrust coefficients for the 55- and 65-percent exhaust nozzles are presented in figure 16(a) as a function of fuel-air ratio for a simulated altitude of 45,000 feet. These thrust coefficients were estimated with the assumption that 97 percent of the ideal one-dimensional value of $pA(1+\gamma M^2)$ was available at the nozzle exit for each nozzle. Design nozzle-exit areas of 79 and 93 percent of the combustion-chamber area were used in the thrust-coefficient calculations for the 55- and 65-percent nozzles, respectively.

The thrust coefficient increased with fuel-air ratio for both nozzles. The inlet diffuser was critical for the 55-percent nozzle at a fuel-air ratio of 0.055 and the thrust coefficient was 1.29. For the 65-percent nozzle the highest attainable combustion-chamber temperature rise was reached at a fuel-air ratio of 0.073 and this occurred before the diffuser was critical. At this fuel-air ratio of 0.073 the peak thrust coefficient for the 65-percent-nozzle engine was

1.32, a very small improvement over the critical-diffuser value of 1.29 obtained with the 55-percent nozzle. For a given thrust coefficient the required fuel-air ratio was from 20 to 40 percent greater for the 65-percent than for the 55-percent nozzle. Thus, cruise operation would be seriously compromised by use of the 65-percent nozzle.

Effect of increased combustion-chamber-inlet Mach number on combustion. - At a given temperature rise across the combustion chamber the combustion-chamber-inlet Mach numbers were theoretically about 18 percent higher for the 65-percent exhaust nozzle than for the 55-percent nozzle. These higher Mach numbers (or velocities) resulted in differences in both the limits of combustion and combustion efficiencies obtained with the two nozzles.

A comparison of the limits of combustion obtained with the 65- and 55-percent nozzles is shown in figure 16(b). The curves shown in figure 16(b) define the lowest combustion-chamber-exit total pressure for which stable combustion could be maintained at a given fuel-air ratio. For combustion-chamber-exit pressures greater than 800 pounds per square foot, the lean and rich limits of combustion for the 65-percent nozzle occurred at lower fuel-air ratios than the limits of combustion for the 55-percent nozzle. According to the basic theory, which was discussed previously in presenting the effects of flame-holder geometry on limits of combustion, the fuel-air ratios defining the lean limits of combustion for the 65-percent nozzle would be expected to increase over those ratios obtained with the 55-percent nozzle and the fuel-air ratios defining the rich limits would be expected to decrease according to some function of the increased combustion-chamber-inlet Mach numbers associated with the 65-percent nozzle. The poorer rich limit obtained with the 65-percent nozzle is in accord with the theory, but the better lean limits obtained for both uniform and annular injection with the 65-percent nozzle apparently contradict the theory. Apparently the higher velocities associated with the 65-percent nozzle reduced the penetration of the fuel sprayed into the air stream so that rich zones of fuel-air ratio beneficial to the lean limits of combustion were more effectively preserved in the flow stream down to the flame holder.

A comparison of combustion efficiencies obtained with the 65- and 55-percent nozzle is shown in figure 16(c). The curve for the 65-percent nozzle is for a simulated altitude of 45,000 feet; the curve for the 55-percent nozzle was obtained by cross-plotting so that at every fuel-air ratio the combustion-chamber-exit pressure was equal to that obtained for the 65-percent nozzle. Thus, at a given fuel-air ratio, differences in combustion efficiency shown are attributable to differences in combustion-chamber-inlet Mach number and attendant effects.

Combustion efficiencies obtained with uniform injection were equal for both nozzles at a fuel-air ratio of 0.076. Between fuel-air ratios of 0.062 and 0.076 the combustion efficiencies obtained with the 65-percent nozzle were slightly lower than those obtained with the 55-percent nozzle. As fuel-air ratio was reduced below 0.062 the deterioration of combustion efficiency with decreasing fuel-air ratio became progressively more pronounced for the 65-percent nozzle. Thus, as fuel-air ratio was reduced combustion efficiency became more sensitive to the higher combustion-chamber-inlet Mach numbers associated with the 65-percent nozzle.

Effect of Fuel Volatility

High-speed Diesel fuel was used to determine the effect of fuel volatility on combustion performance because availability might necessitate the use of a fuel other than the design fuel, heptane. The Diesel fuel used in the investigation had a 50-percent distillation point of 509° F compared with 206° F for normal heptane.

The performance of the engine when operated with Diesel fuel was found, after brief running, to be unsatisfactory and as a result only limited data were obtained. The results, however, when compared with those obtained with normal heptane, illustrated some of the basic combustion-chamber design changes required for satisfactory utilization of Diesel fuel.

Comparison of limits of combustion for Diesel fuel and normal heptane. - A comparison of the uniform-injection lean limits of combustion for configuration 5 obtained with Diesel fuel and normal heptane is shown in figure 17(a). The limits were slightly better for Diesel fuel above an altitude of 50,000 feet and slightly better for normal heptane below an altitude of 50,000 feet. Despite the fact that no physical changes were made to adapt the engine to the less volatile Diesel fuel, the quantity of fuel vaporized provided a flame-stabilizing fuel-air mixture at the flame holder which was as good as that obtained for heptane.

Comparison of combustion efficiencies for Diesel fuel and normal heptane. - A comparison of combustion efficiencies obtained with uniform injection for Diesel fuel and normal heptane is presented in figure 17(b). The curves shown are for a simulated altitude of 45,000 feet. Over the range of fuel-air ratios investigated, the combustion efficiency obtained with Diesel fuel was 10 to 20 percentage points lower than that obtained with heptane. The combustion efficiency obtained with Diesel fuel increased only slightly, from 38 to 44 percent, as fuel-air ratio increased from 0.040 to 0.056. For normal heptane the combustion efficiency increased from 48 to 66 percent

2387

for the same increase in fuel-air ratio. The nearly constant and low combustion efficiency obtained for Diesel fuel over the complete range of fuel-air ratios investigated indicates that a large percentage of the total combustion taking place was confined to the wake regions immediately following the flame-holder gutters. Combustion in these regions was apparently similar for both Diesel fuel and normal heptane as evidenced by similarity of the limits of combustion (fig. 17(a)). The better vaporization characteristics of heptane permitted better combustion as the mixture progressed down the combustion chamber, resulting in higher combustion efficiencies and progressively improving combustion efficiencies with increasing fuel-air ratio. Longer vaporization times (greater distance between point of injection and flame holder) and higher injection pressures for better fuel atomization probably would have improved the combustion efficiencies obtained with Diesel fuel.

Effect of Combustion-Chamber-Inlet Temperature

For engine operation at off-design flight Mach numbers and on non-standard days the combustion-chamber-inlet temperature would deviate from 250° F, the value corresponding to a flight Mach number of 2.0 above the tropopause. The effects of variations in inlet temperature on combustion were determined by runs with configuration 5 at inlet temperatures of 150°, 250°, and 350° F. The results obtained are subject to a correction for charge-air contamination by the combustion heater which varied with inlet temperature. As was previously stated, however, the effects of contamination on engine combustion were probably small over the range of combustion-heater fuel-air ratios used (0.001 to 0.004).

Combustion efficiency. - The effect of temperature on combustion efficiency is shown in figure 18 for uniform injection. Curves are shown for a fuel-air ratio of 0.065 at a combustion-chamber-exit pressure of 1400 pounds per square foot and for a fuel-air ratio of 0.040 at a combustion-chamber-exit pressure of 1000 pounds per square foot. Combustion efficiency increased with inlet temperature for both the high and low fuel-air ratio conditions. For an increase in temperature from 150° to 350° F the combustion efficiency increased from 41 to 50 percent with a fuel-air ratio of 0.040 and from 70 to 90 percent with a fuel-air ratio of 0.065.

Limits of combustion. - The effect of temperature on the limits of combustion is shown in figure 19. These limits define the lowest combustion-chamber-exit pressure for which stable combustion could be maintained at a given fuel-air ratio. Sets of curves for inlet temperatures of 150°, 250°, and 350° F are shown for uniform and annular injection. In general, for both types of injection, the stable

operating pressure at a given fuel-air ratio decreased as inlet temperature increased. A departure from this trend occurred in the region of fuel-air ratios between 0.050 and 0.056 where the minimum operating pressure for 150° F became lower than that for either 250° or 350° F. At a given combustion-chamber-exit pressure the stable operating range of fuel-air ratios increased as inlet temperature was raised.

CONCLUDING REMARKS

In an altitude test-chamber investigation of the performance of a 28-inch diameter ram-jet engine, the original configuration was found to be unsatisfactory from the standpoint of inadequate combustion limits. Variation in the combustion-chamber features resulted in a design that, although not completely satisfactory with respect to combustion efficiency, would operate over a range of fuel-air ratios greater than that required by the proposed flight plan.

Fuel distribution and flame-holder geometry significantly affected limits of combustion but did not affect combustion efficiency. Use of a double-manifold fuel-injection system in place of the original single-manifold system improved the rich limits of combustion by distributing the fuel more uniformly at high fuel-air ratios and improved the lean limits of combustion by permitting maintenance of locally rich fuel-air ratios at low over-all fuel-air ratios. The primary factor in flame-holder geometry affecting limits of combustion was gutter width. In general, wider gutters improved both the rich and lean limits of combustion. Combustion efficiency was relatively independent of flame-holder geometry over a wide range of blocked areas and gutter widths.

The presence of a pilot burner aided in stabilizing combustion at the lean over-all fuel-air ratios by providing a small but constantly burning region of approximately stoichiometric mixture. The effect of the pilot burner on combustion efficiency was small, however, inasmuch as the pilot flame served primarily as an igniting and combustion stabilizing mechanism and did not contribute to completeness of combustion after continuous ignition had been achieved.

The imposition of high combustion-chamber-inlet Mach numbers by the use of an exhaust nozzle throat area larger than the original (65- and 55-percent of the combustion-chamber area, respectively) resulted in better lean limits but poorer rich limits of combustion. These effects on the limits of combustion were attributed to the reduction in the spreading of the conical fuel spray pattern, which preserved a stratum of rich mixture in the flow stream down to the flame holder. Combustion efficiency at high fuel-air ratios was insensitive to the higher combustion-chamber-inlet Mach numbers but

became progressively more sensitive to the higher Mach numbers and decreased more rapidly for the large exhaust nozzle as fuel-air ratio was reduced.

2587
Lean limits of combustion obtained with both low-volatility Diesel fuel and high-volatility commercial-grade normal heptane were similar. The quantity of Diesel fuel vaporized apparently provided a flame-stabilizing fuel-air mixture at the flame holder which was as good as that obtained with heptane. Combustion efficiencies obtained with the lower volatility Diesel fuel were, however, lower than those obtained with normal heptane because of the lower vaporization rate of Diesel fuel.

In general, the limits of combustion and combustion efficiency were improved as combustion-chamber-inlet temperature was increased. The increasing rate of fuel vaporization with increasing inlet temperature resulted in better flame-stabilizing mixtures at the flame holder and an accelerated over-all combustion process.

Lewis Flight Propulsion Laboratory
National Advisory Committee for Aeronautics
Cleveland, Ohio.

APPENDIX - SYMBOLS

The following symbols are used throughout this report:

- A area, sq ft
- C_T jet-thrust coefficient, $\frac{\gamma_6 p_6 A_6 M_6^2 + A_6 (p_6 - p_a)}{q A_4}$
- M Mach number
- P total pressure, lb/sq ft absolute
- p static pressure, lb/sq ft absolute
- q simulated free-stream dynamic pressure, $\frac{\gamma_a p_a M_a^2}{2}$, lb/sq ft absolute
- γ ratio of specific heats
- η combustion efficiency

Subscripts and stations:

- a ambient or free-stream conditions at altitude which is simulated
- 0 test-engine bellmouth inlet
- 1 lip station
- 2 combustion-chamber inlet
- 4 combustion-chamber exit
- 5 exhaust-nozzle throat
- 6 exhaust-nozzle exit

REFERENCES

1. Jones, W. L., Shillito, T. B., and Henzel, J. G., Jr.: Altitude-Test-Chamber Investigation of Performance of a 28-Inch Ram-Jet Engine. I - Combustion and Operational Performance of Four Combustion-Chamber Configurations. NACA RM E50F16, 1950.
2. Shillito, T. B., Jones, W. L., and Kahn, R. W.: Altitude-Test-Chamber Investigation of Performance of a 28-Inch Ram-Jet Engine. II - Effects of Gutter Width and Blocked Area on Operating Range and Combustion Efficiency. NACA RM E50H21, 1950.

- 2387
3. Shillito, Thomas B., Younger, George G., and Henzel, James G., Jr.:
Altitude-Test-Chamber Investigation of Performance of a 28-Inch
Ram-Jet Engine. III - Combustion and Operational Performance of
Three Flame Holders with a Center Pilot Burner. NACA RM E50J20,
1950.
 4. Kahn, Robert W., Nakanishi, Shigeo, and Harp, James L., Jr.:
Altitude-Test-Chamber Investigation of Performance of a 28-Inch Ram-Jet
Engine. IV - Effect of Inlet-Air Temperature, Combustion-Chamber-
Inlet Mach Number, and Fuel Volatility on Combustion Performance.
NACA RM E51D11, 1951.
 5. Williams, Glenn C.: Basic Studies on Flame Stabilization. Jour.
Aero. Sci., vol. 16, no. 12, Dec. 1949, pp. 714-722.

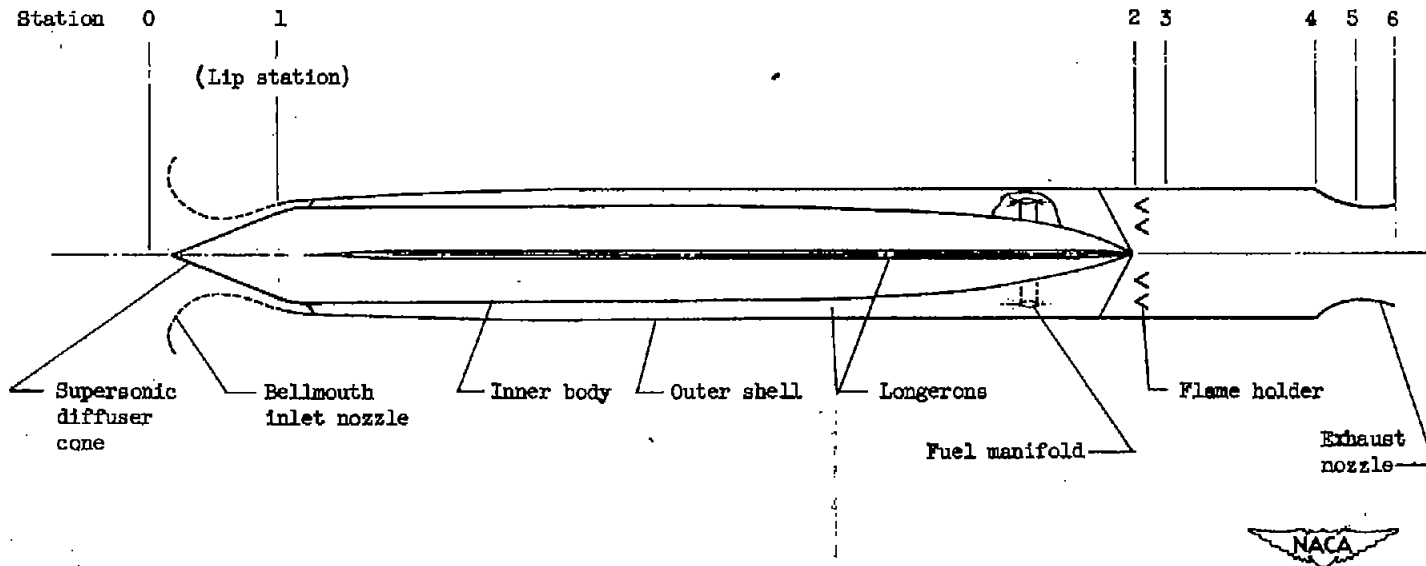
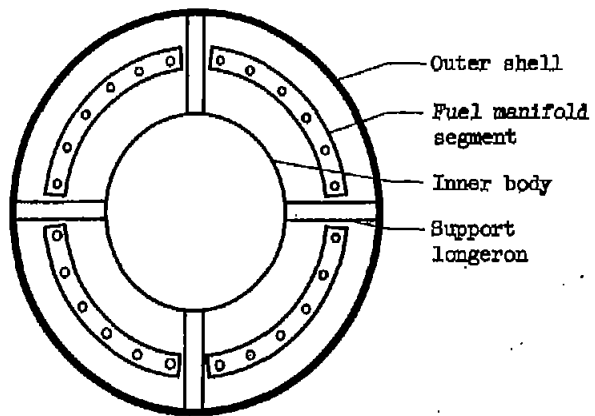

Figure 1. - Schematic diagram of 28-inch diameter ram-jet engine.



Section A-A

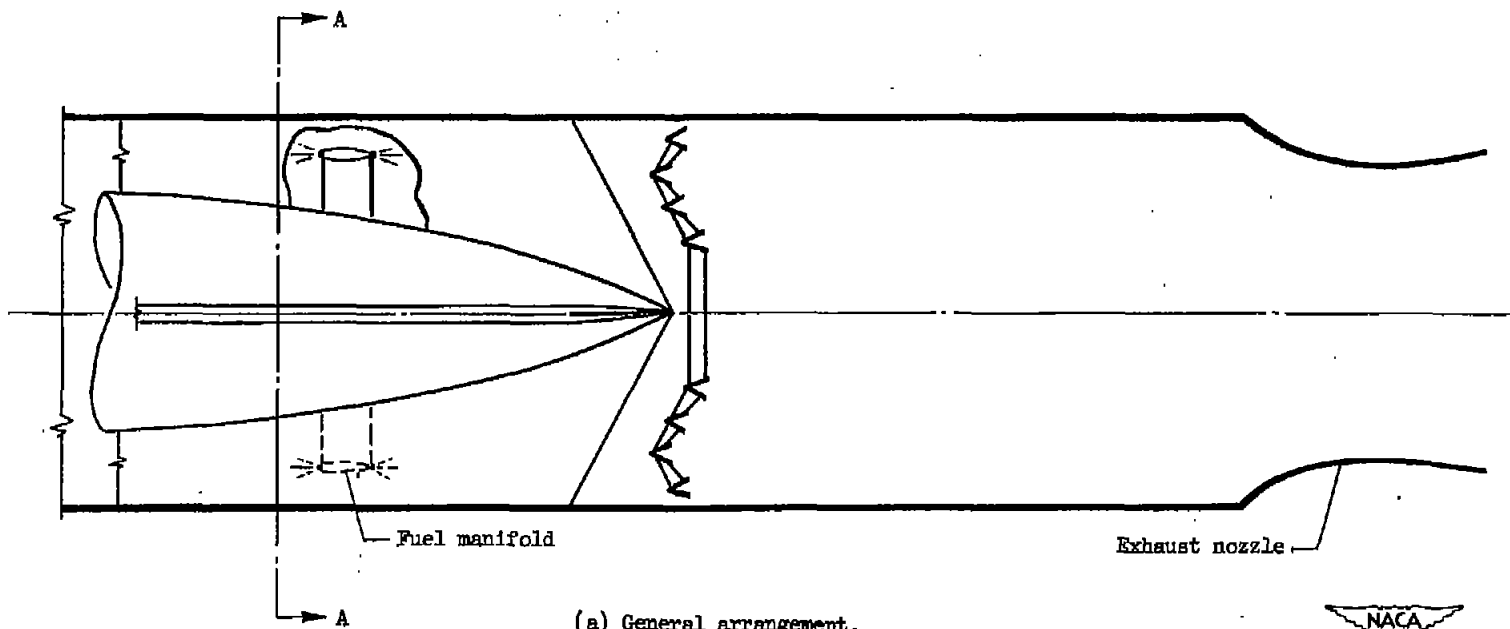
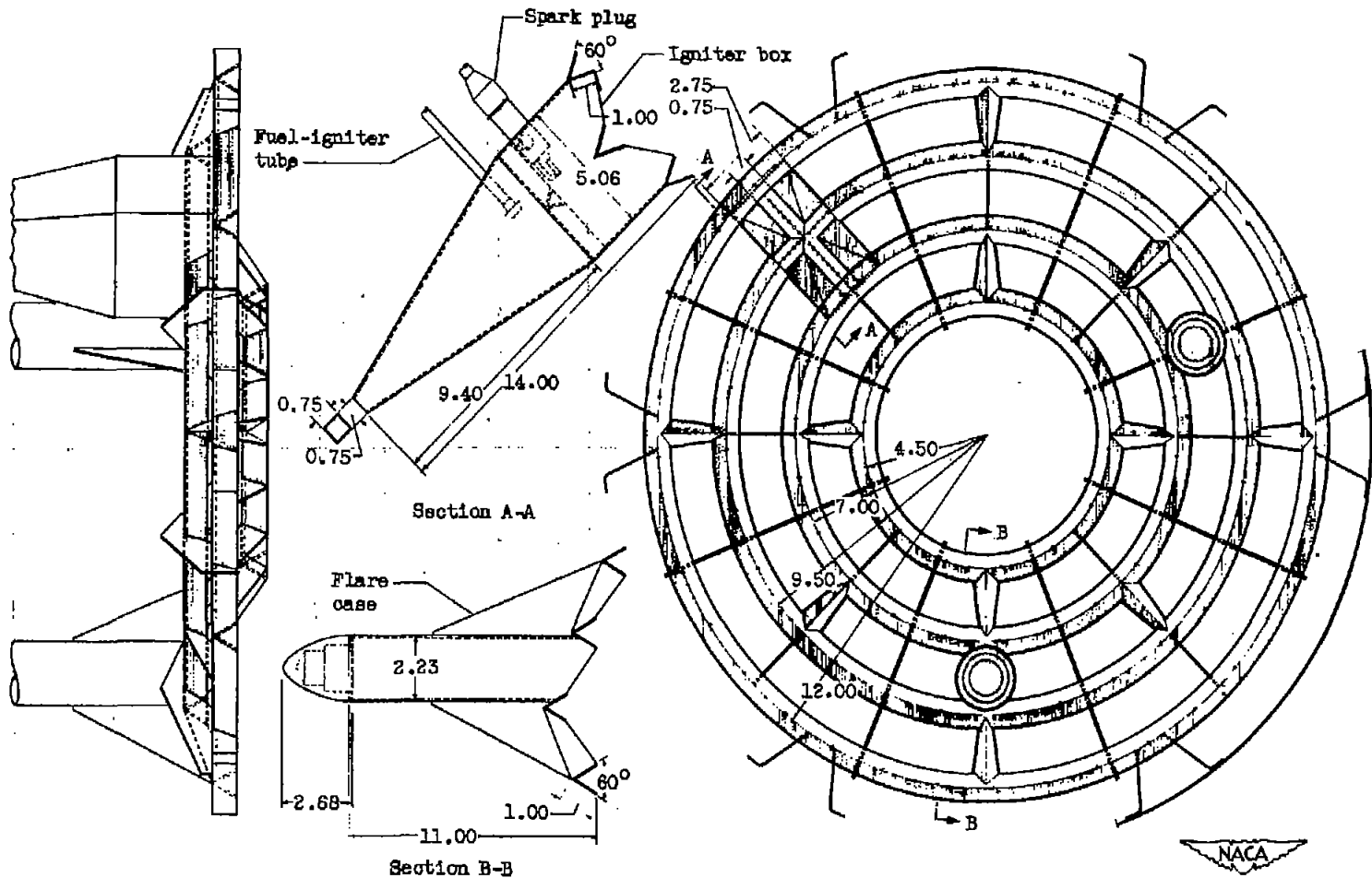

Figure 2. - Schematic diagram of combustion chamber for configuration 1.





(b) Schematic diagram of flame holder for configuration 1; gutter width, 1 inch; blocked area, 42 percent. (All dimensions in inches unless otherwise indicated.)

Figure 2. - Concluded. Schematic diagram of combustion chamber for configuration 1.

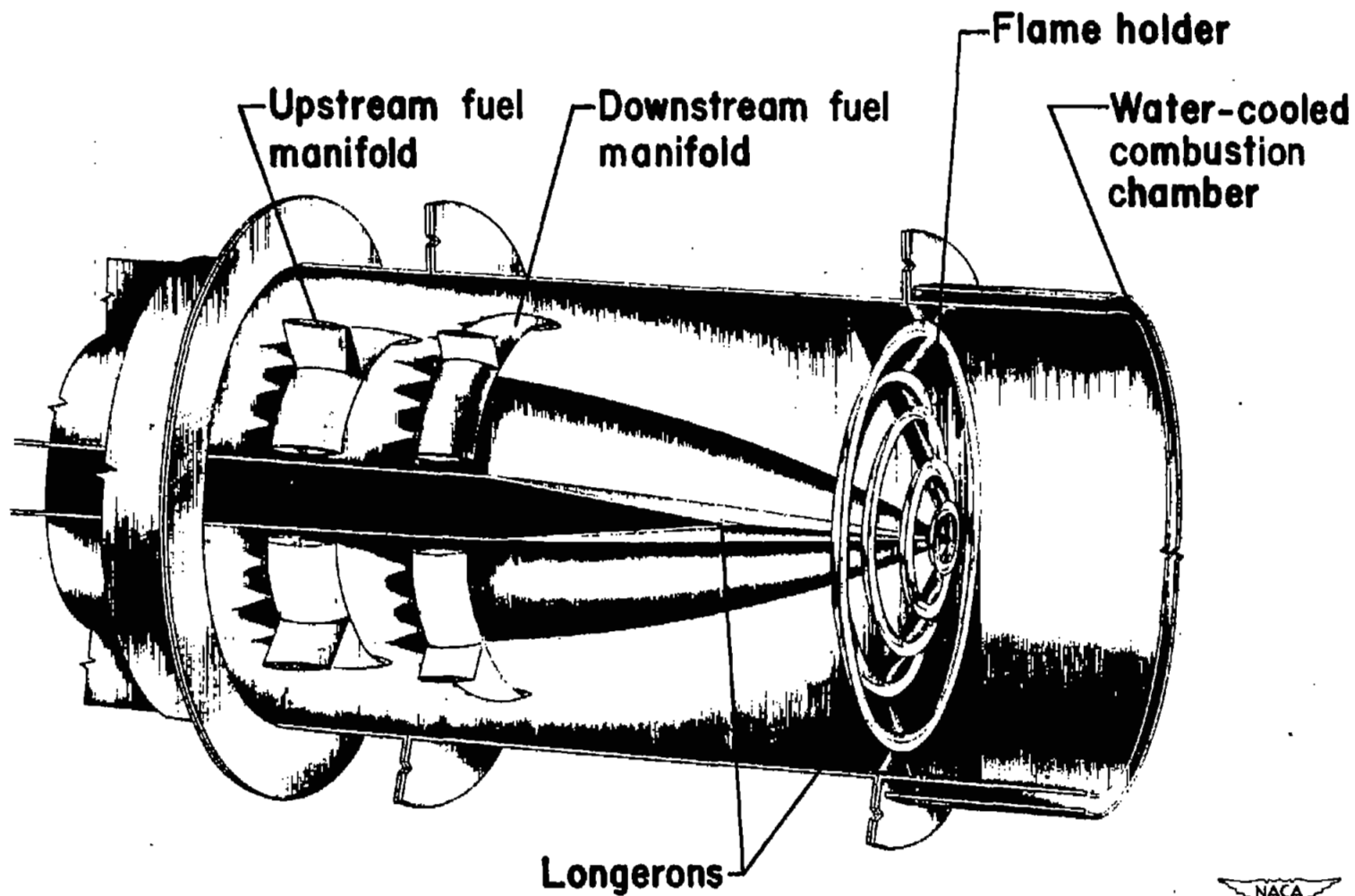

Figure 3. - Arrangement of fuel-injection system, flame holder, and combustion chamber for configurations 2 and 3.



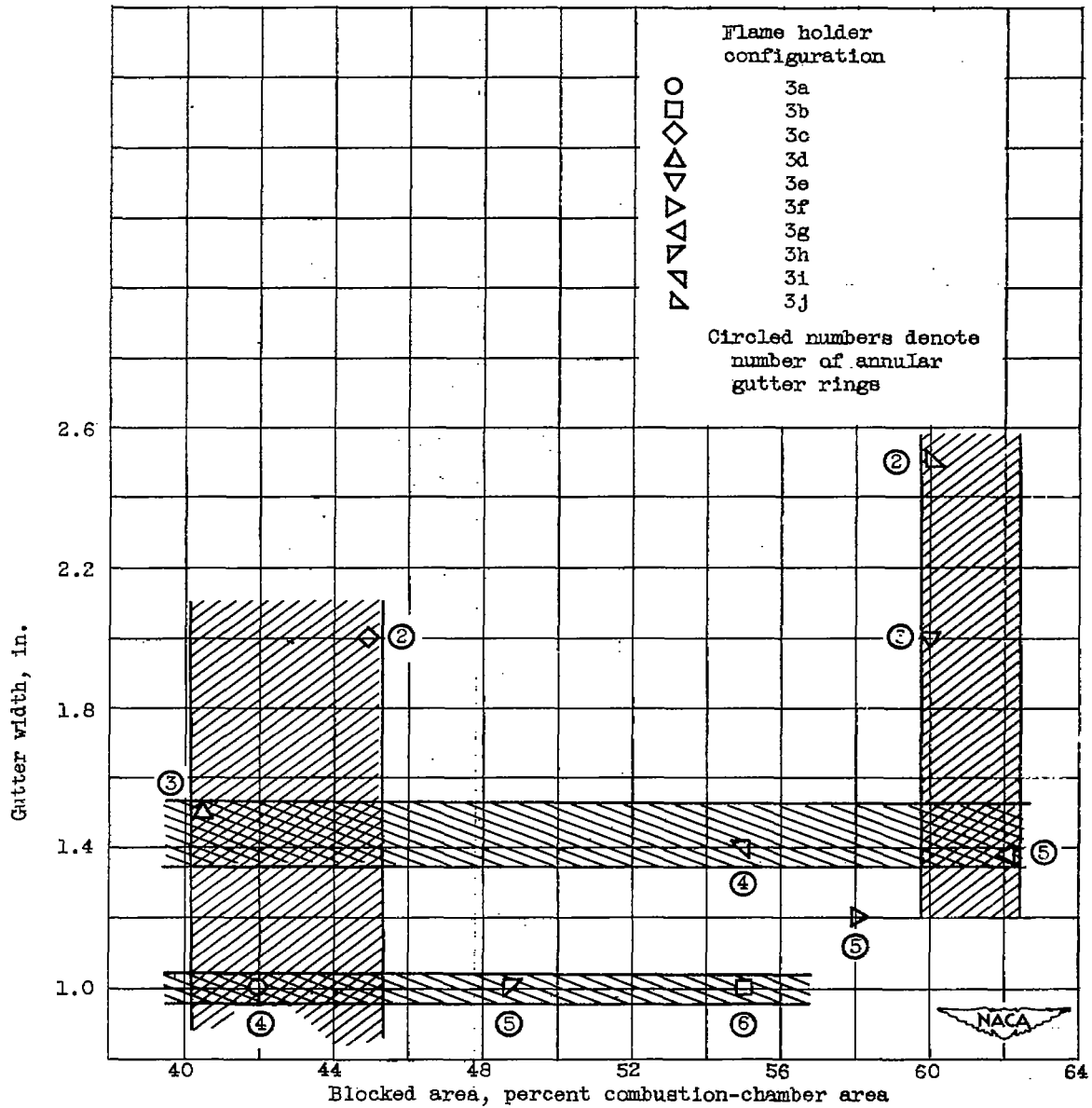

Figure 4. - Gutter width against blocked area of flame holders used in configuration 3.

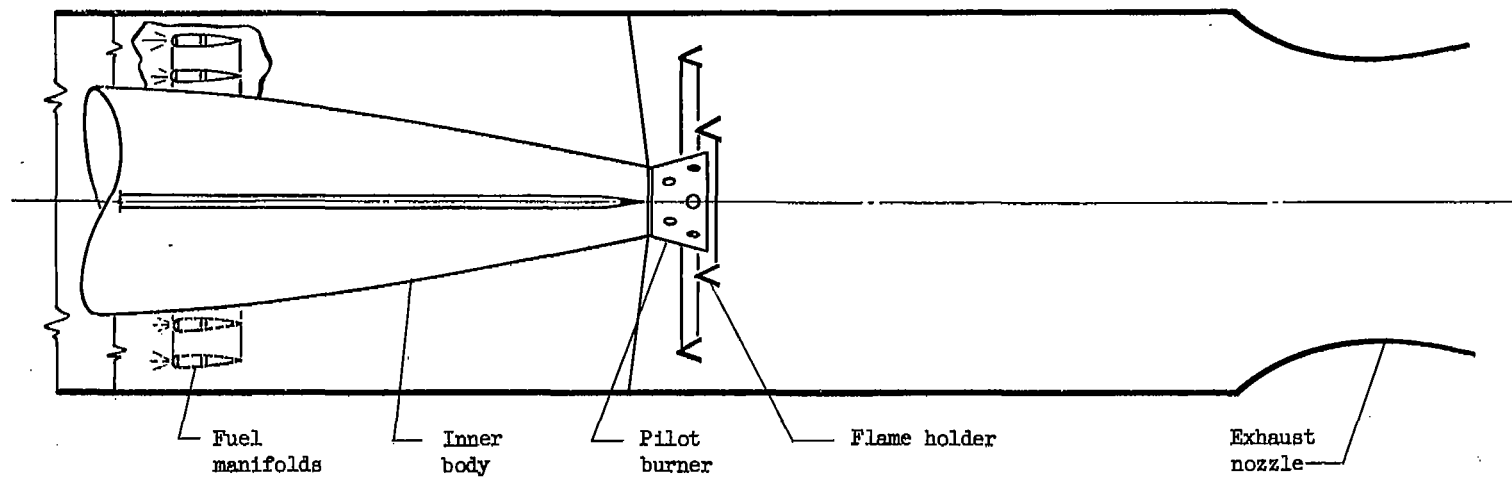

Figure 5. - Schematic diagram of combustion chamber for configuration 4.



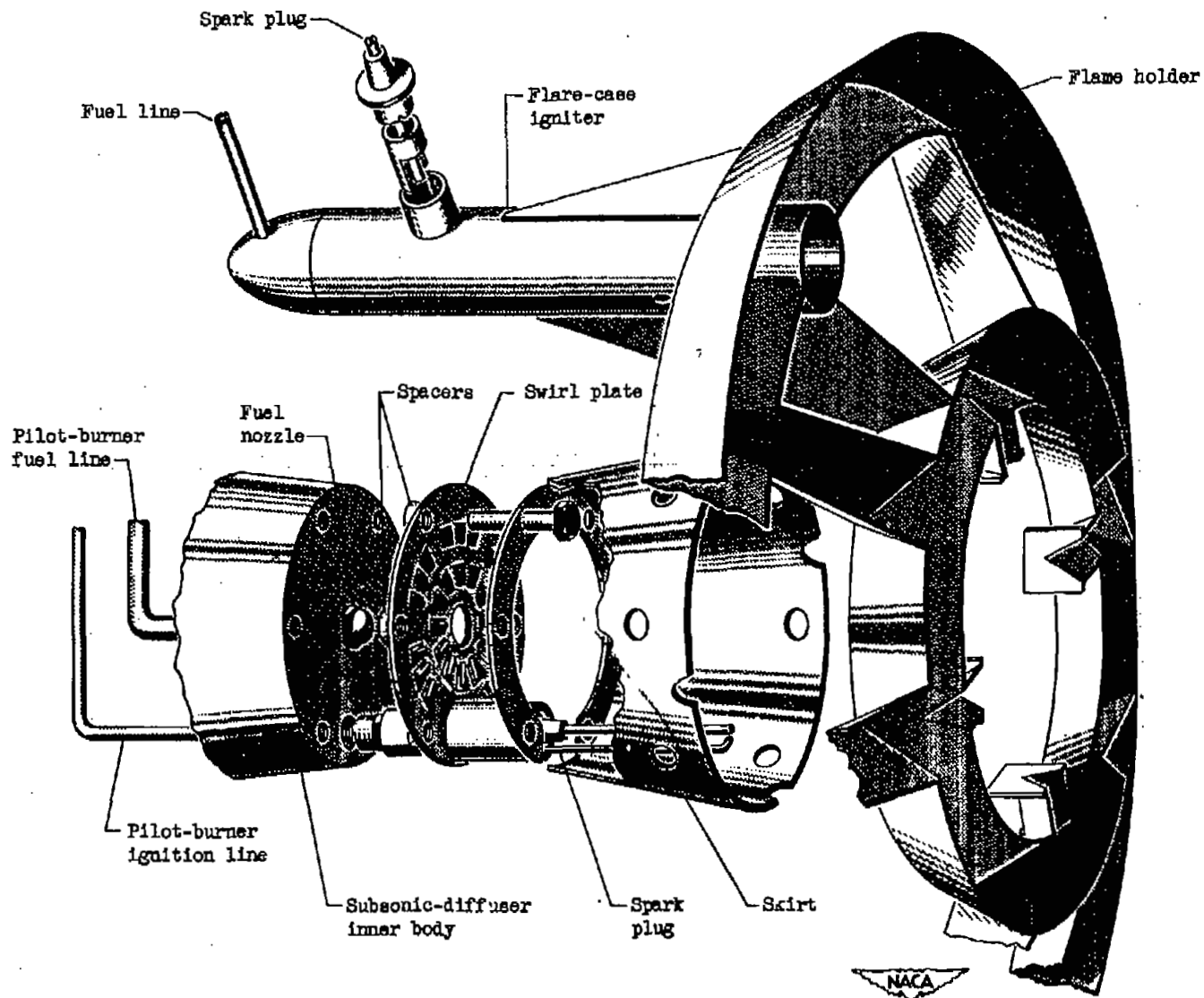

Figure 6. - Disassembled view of pilot burner and flame-holder assembly for configurations 4 and 5.

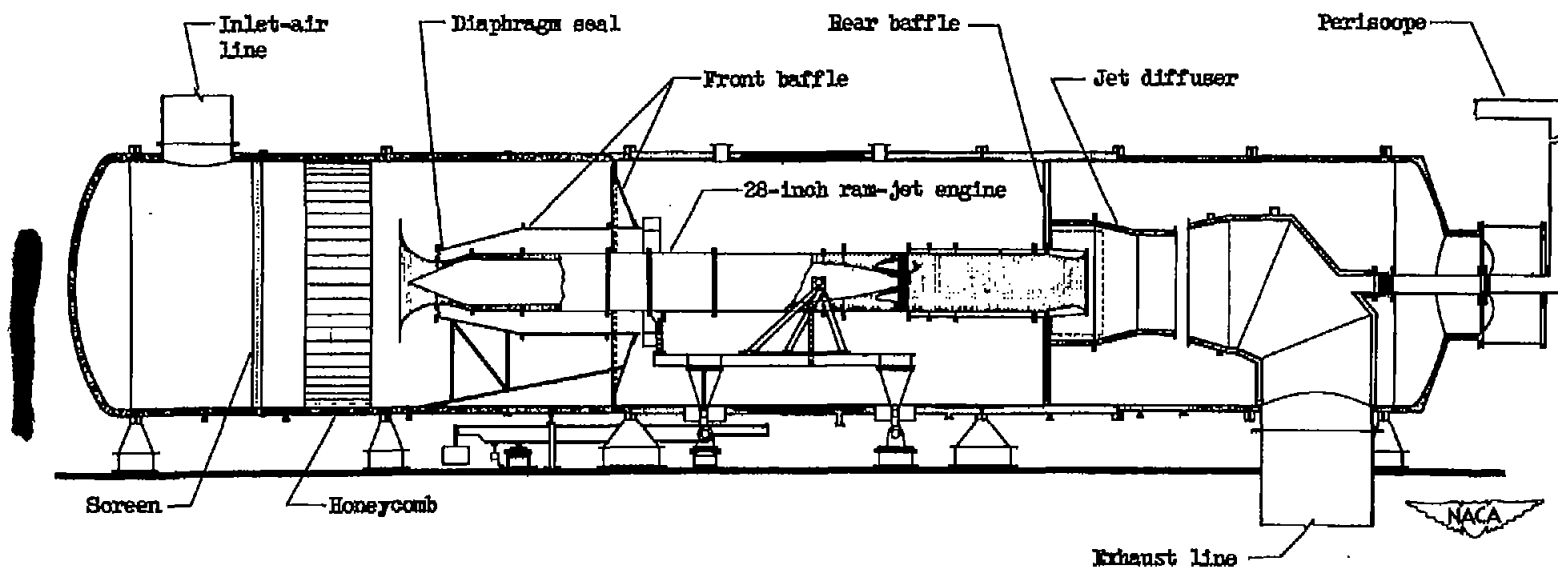
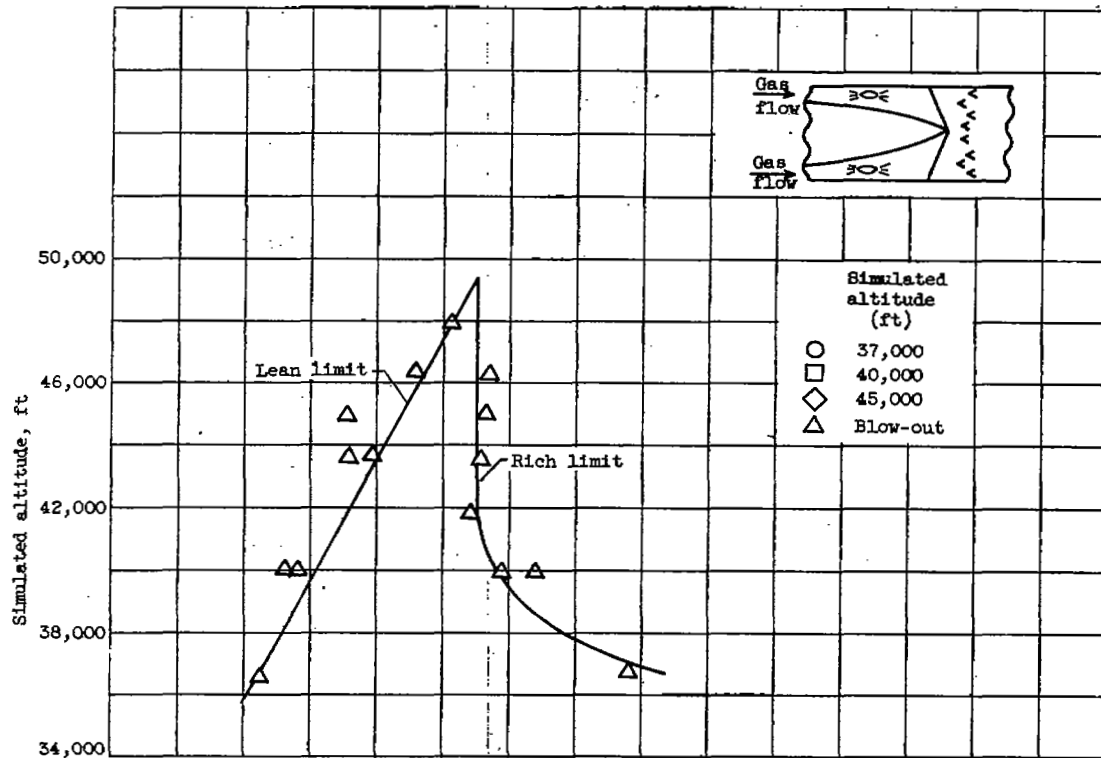
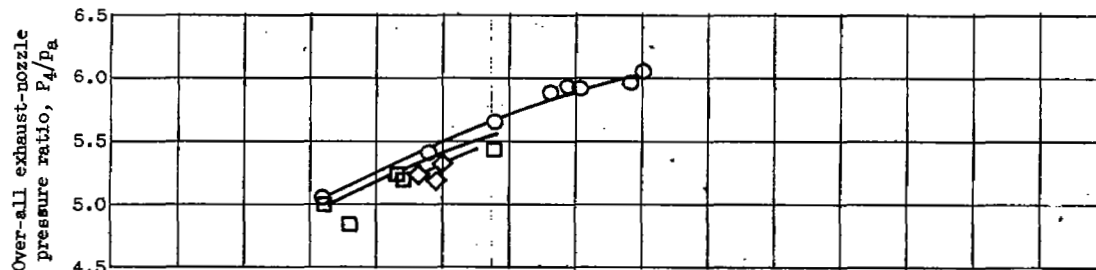

Figure 7. - Schematic diagram of 28-inch ram-jet engine installed in 10-foot altitude test chamber.



(a) Limits of combustion.



(b) Over-all exhaust-nozzle pressure ratio.

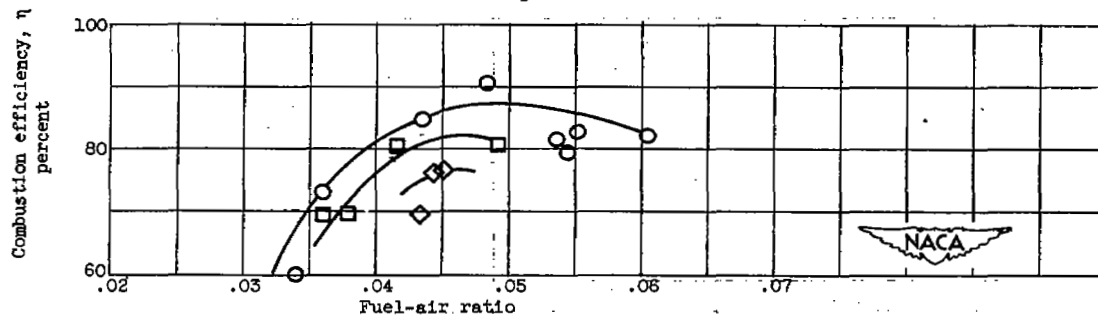

(c) Combustion efficiency.

Figure 8. - Altitude limits of combustion, over-all exhaust-nozzle pressure ratio, and combustion efficiency for configuration 1.

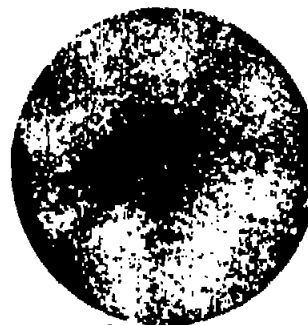
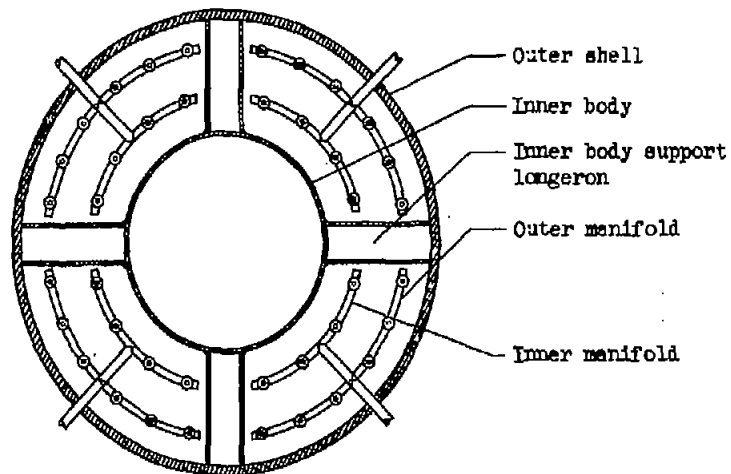

(a) Schematic cross section of double-manifold fuel-injection system.

(b) Photograph of combustion with uniform injection.

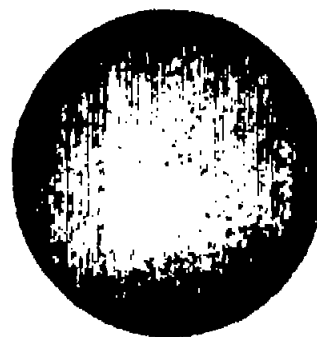

(c) Photograph of combustion with quadrant injection.

(d) Photograph of combustion with annular injection.

Figure 9. - Schematic cross section of double-manifold fuel-injection system and typical photographs of combustion obtained.

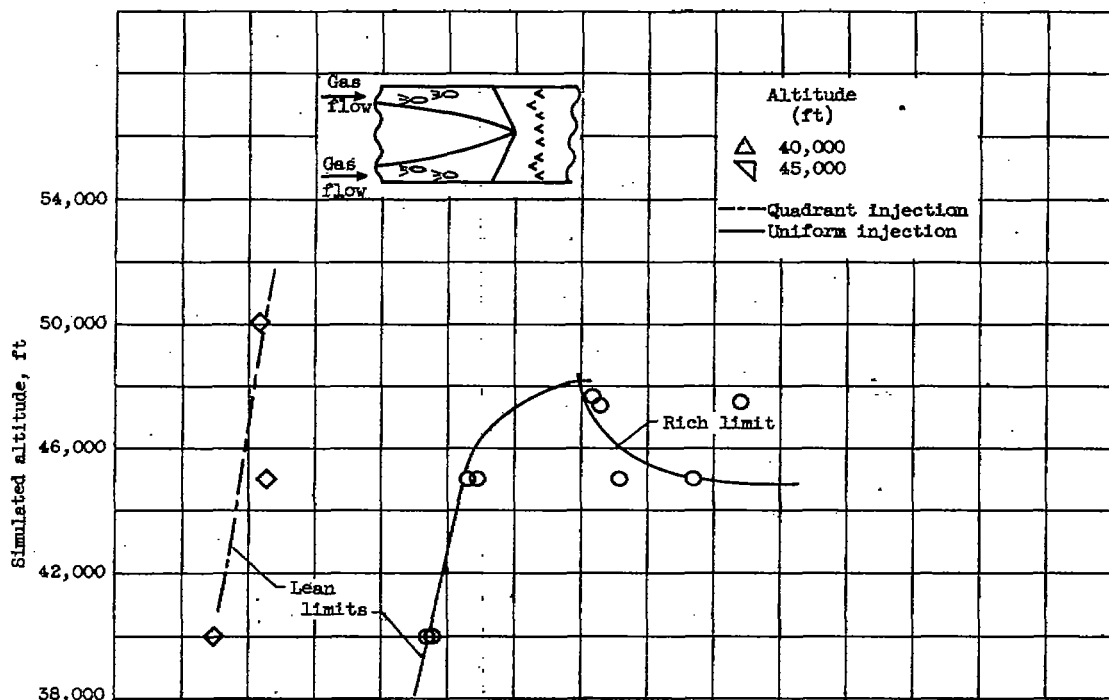

(a) Limits of combustion.

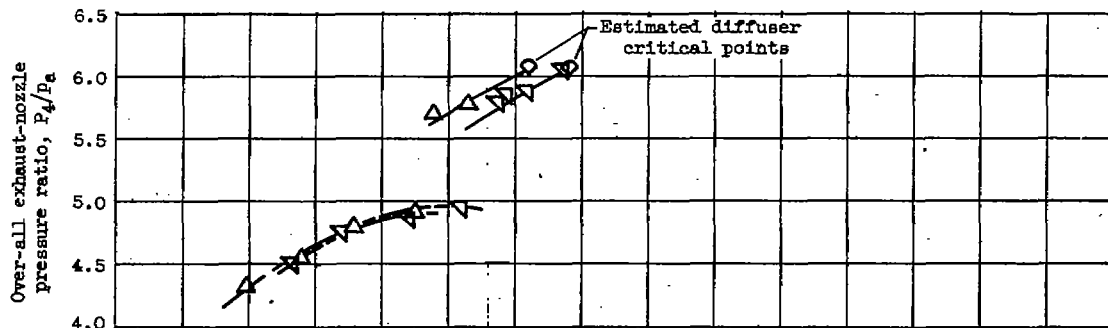

(b) Over-all exhaust-nozzle pressure ratio.

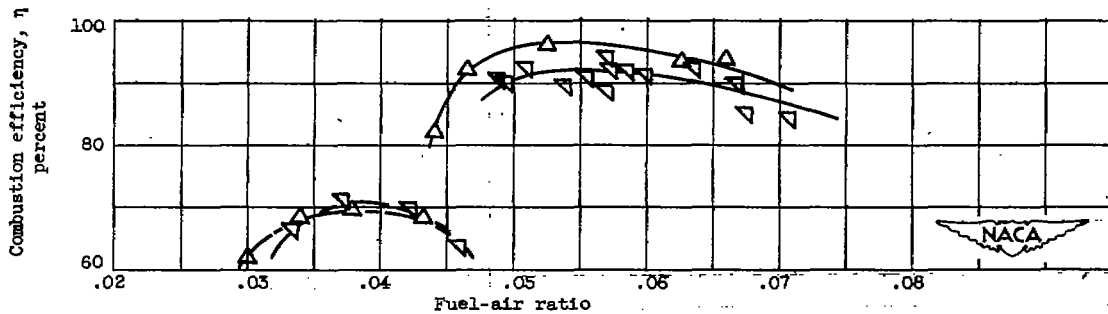

(c) Combustion efficiency.

Figure 10. - Altitude limits of combustion, over-all exhaust-nozzle pressure ratio, and combustion efficiency for configuration 2.

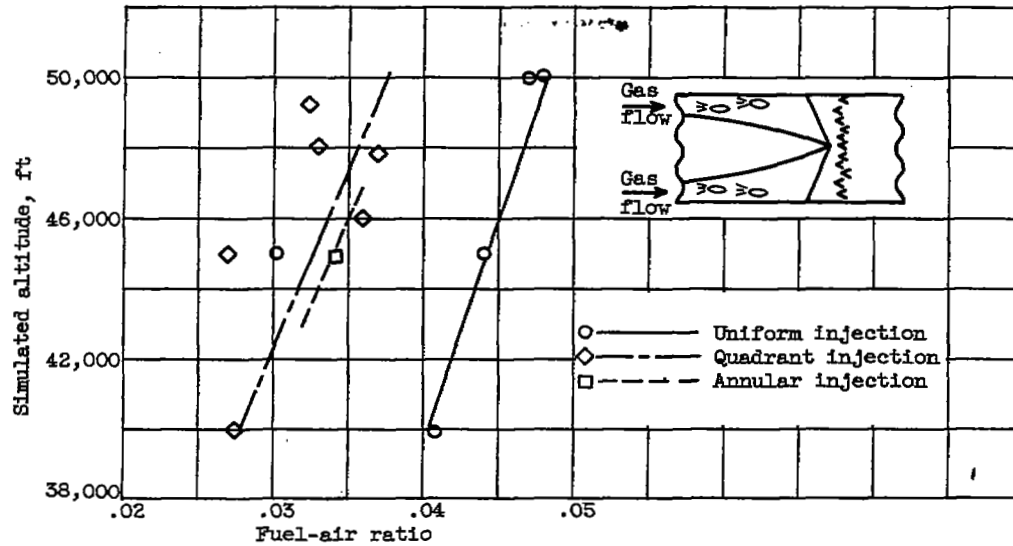

Figure 11. - Comparison of lean limits of combustion obtained with uniform, quadrant, and annular injection for configuration 3(b).

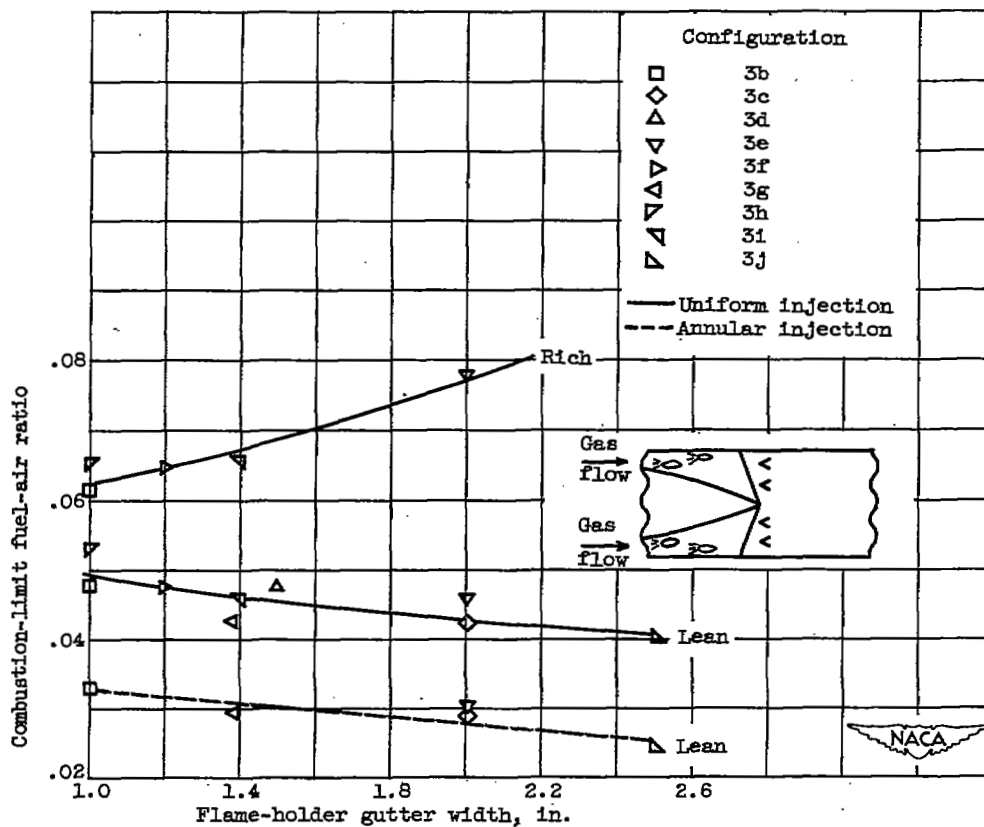

Figure 12. - Effect of flame-holder gutter width on limits of combustion. Combustion-chamber-exit pressure, 1400 pounds per square foot absolute.

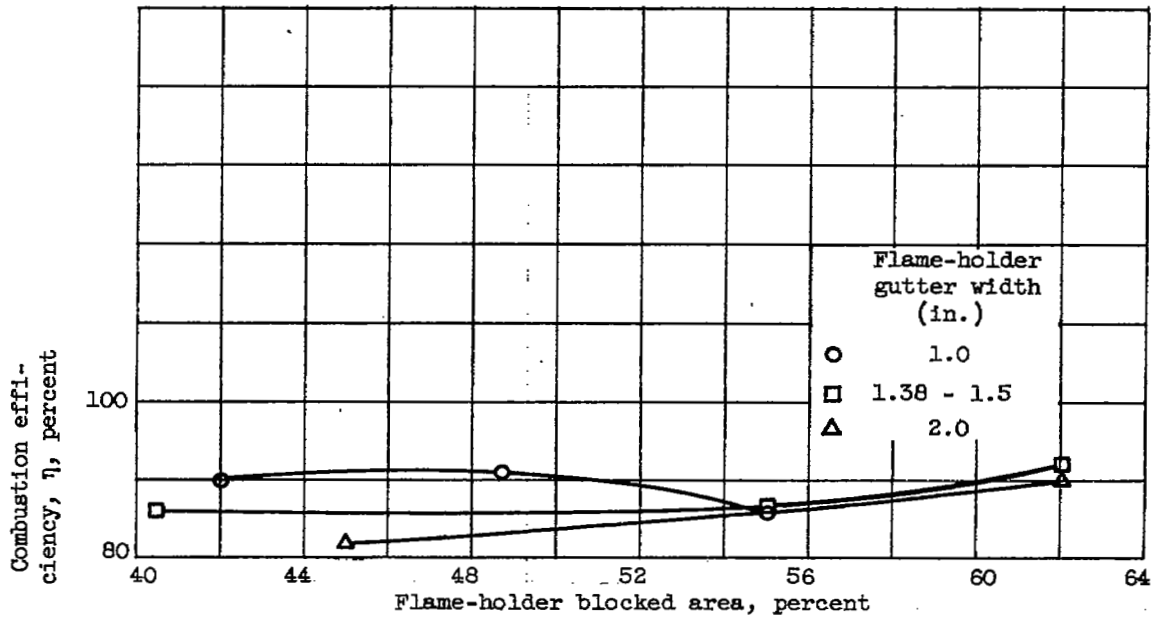

Figure 13. - Effect of flame-holder blocked area on combustion efficiency for configuration 3. Fuel air ratio, 0.050; uniform injection. Combustion-chamber-exit pressure, 1800 pounds per square foot absolute.

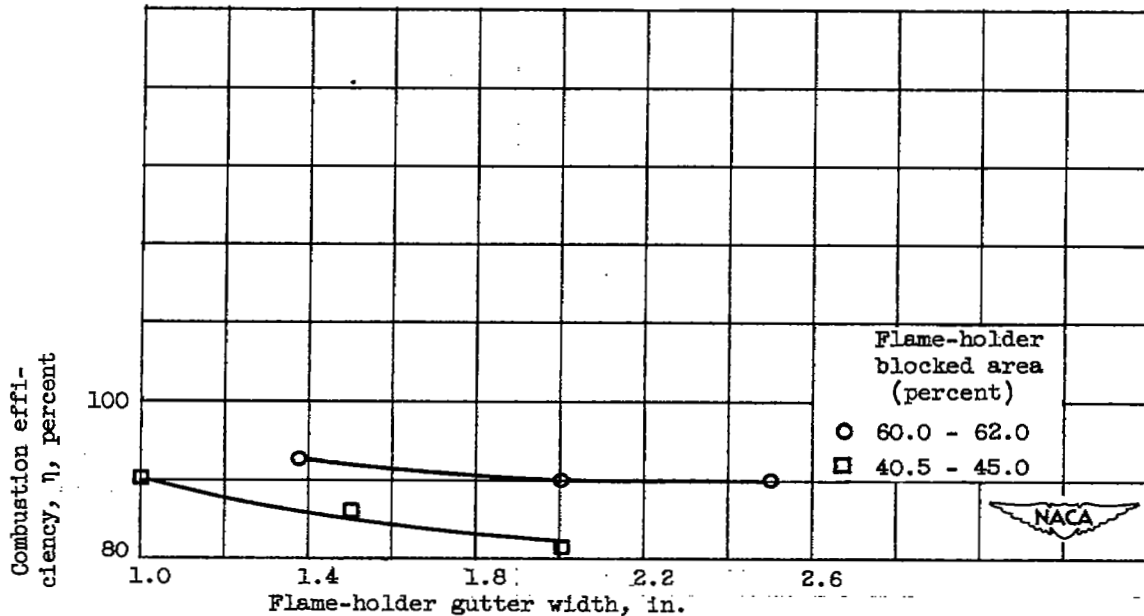
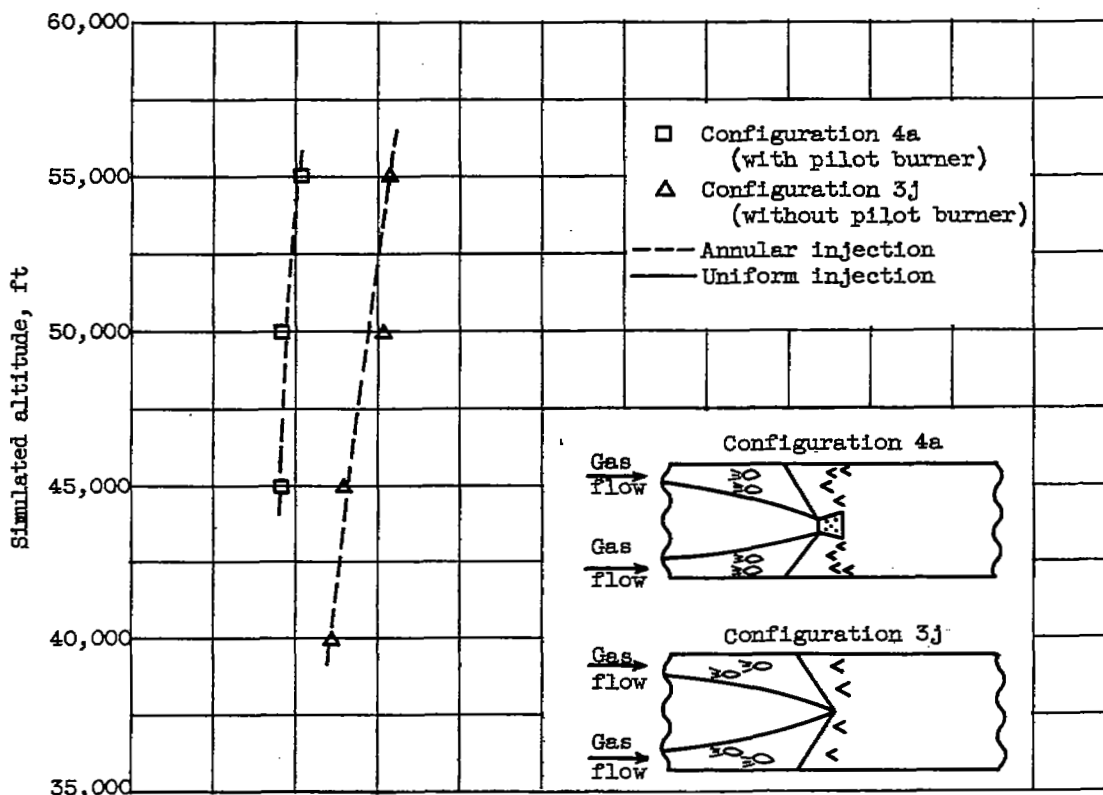
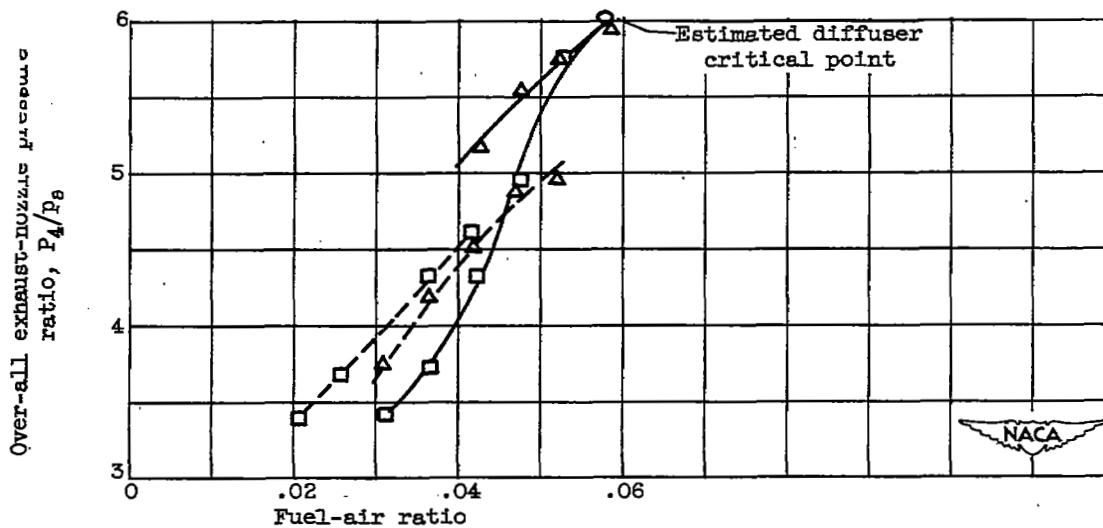

Figure 14. - Effect of flame-holder gutter width on combustion efficiency for configuration 3. Fuel-air ratio, 0.050; uniform injection. Combustion-chamber-exit pressure, 1800 pounds per square foot absolute.



(a) Lean limits of combustion.



(b) Over-all exhaust-nozzle pressure ratio; simulated altitude, 50,000 feet.

Figure 15. - Comparison of lean limits of combustion and over-all exhaust-nozzle pressure ratio for configurations with and without pilot burner.

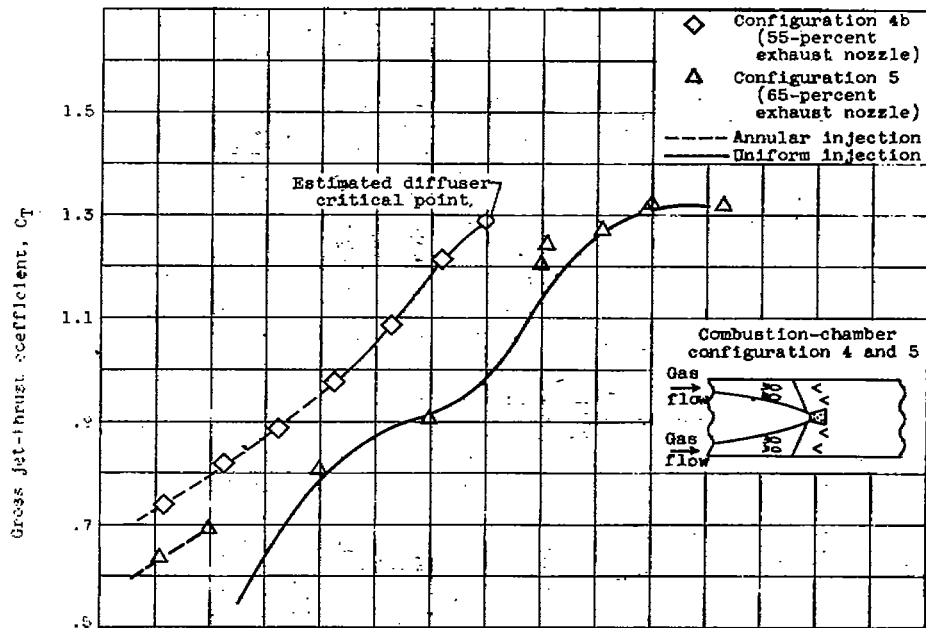

(a) Gross jet-thrust coefficient; simulated altitude, 45,000 feet.

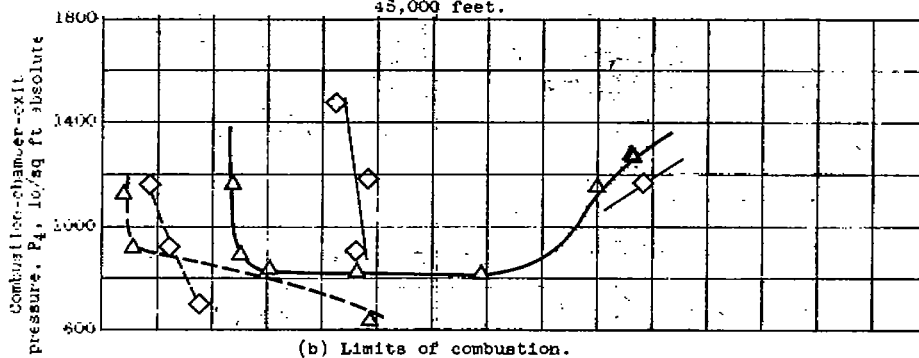

(b) Limits of combustion.

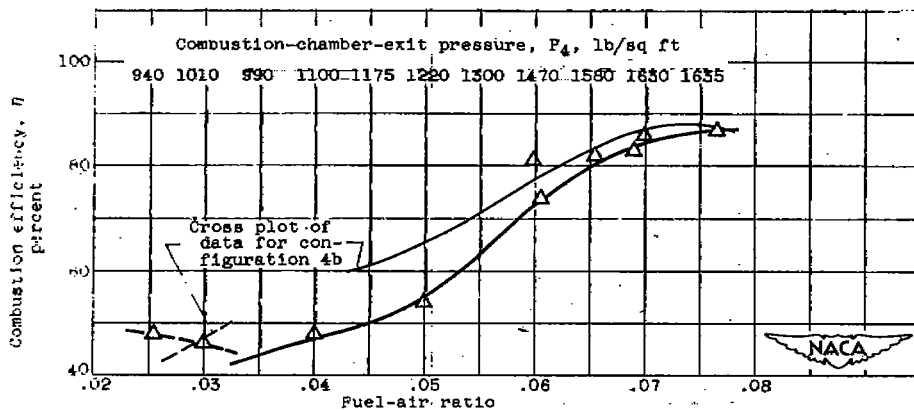

(c) Combustion efficiency; simulated altitude, 45,000 feet.

Figure 16. - Comparison of gross jet-thrust coefficient, limits of combustion, and combustion efficiency for configurations with exhaust nozzles having throat areas of 55 and 65 percent of combustion-chamber area.

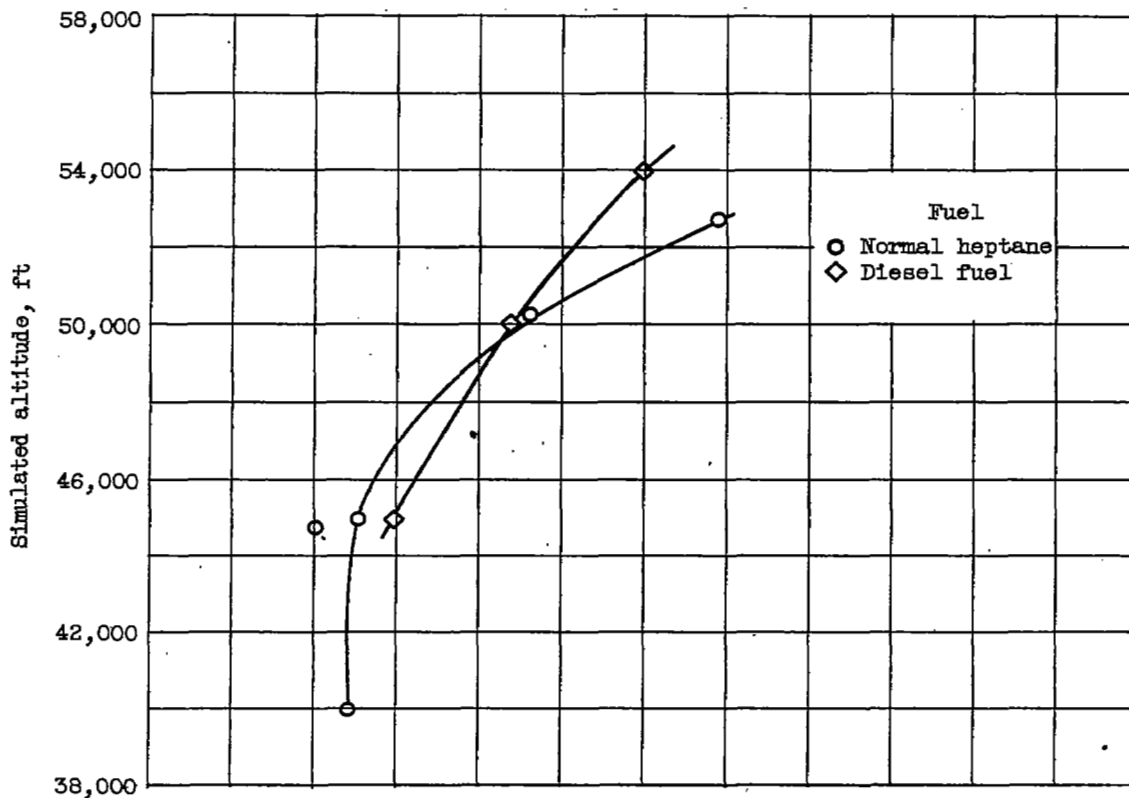

(a) Limits of combustion.

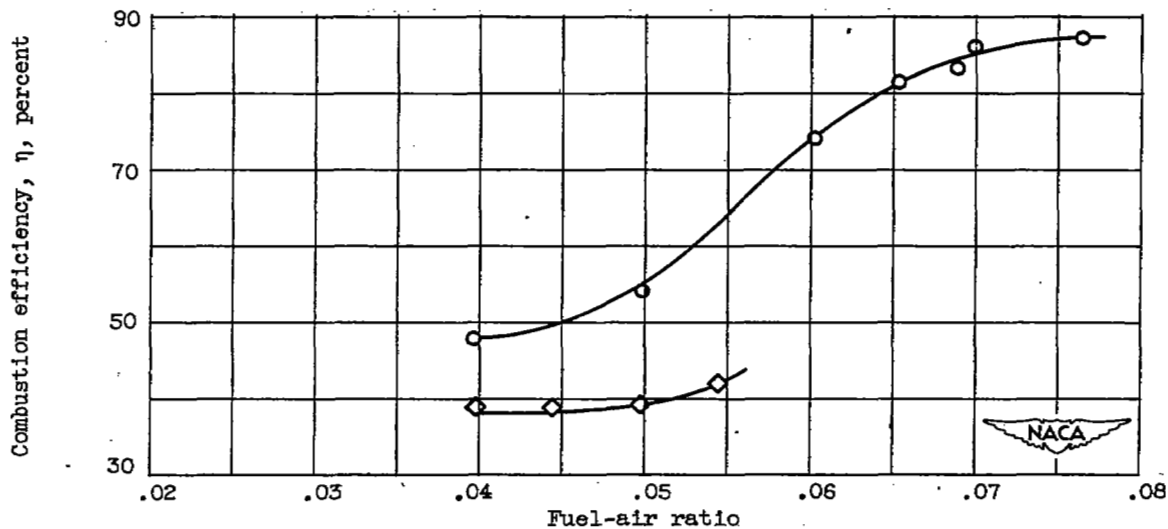

(b) Combustion efficiency; simulated altitude, 45,000 feet.

Figure 17. - Comparison of limits of combustion and combustion efficiency obtained with Diesel fuel and normal heptane for configuration 5. Uniform injection.

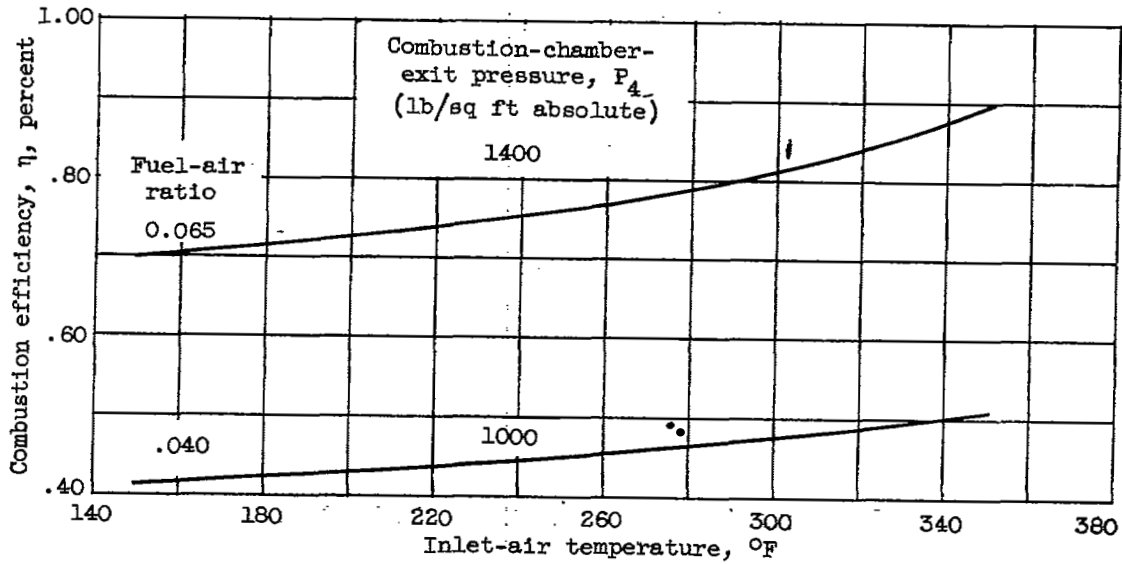

Figure 18. - Effect of inlet-air temperature on combustion efficiency for configuration 5. Uniform injection.

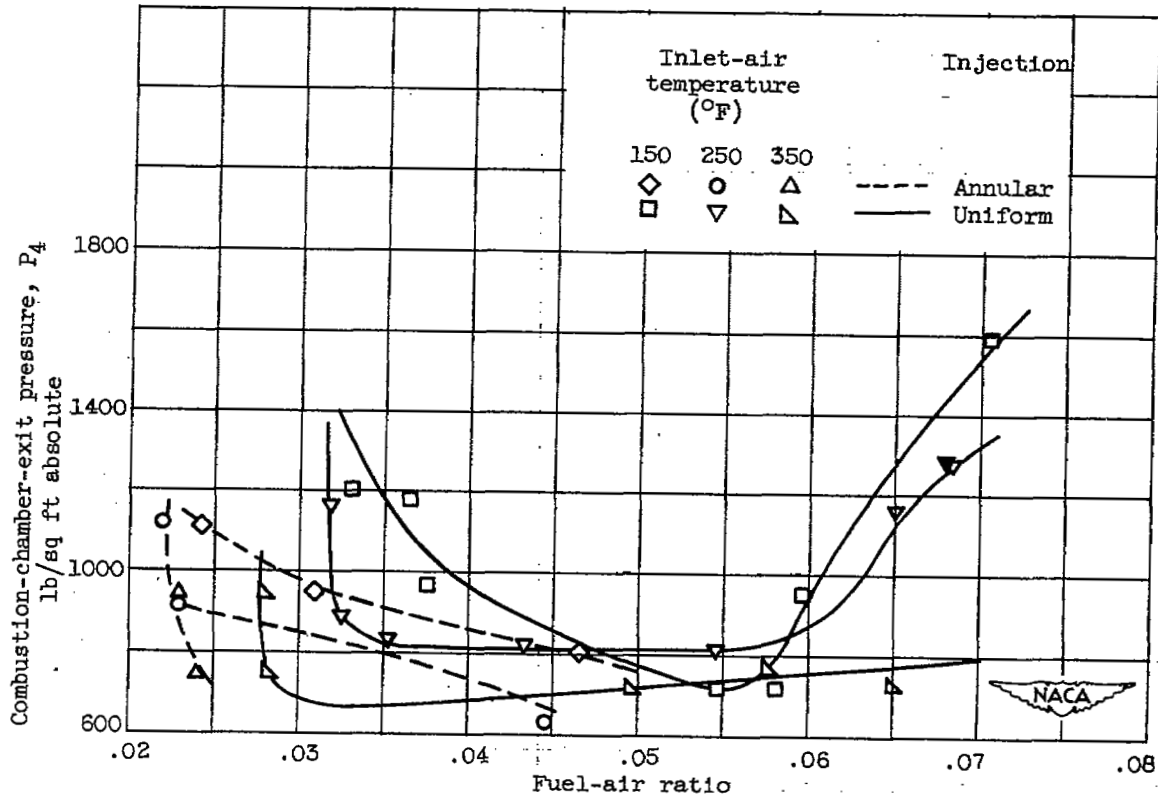

Figure 19. - Effect of inlet-air temperature on limits of combustion for configuration 5.

SECURITY INFORMATION



3 1176 01434 9717

UNCLASSIFIED

UNCLASSIFIED

