



RESEARCH MEMORANDUM

SOME EFFECTS OF A SONIC JET EXHAUST ON THE LOADING
OVER A YAWED FIN AT A MACH NUMBER OF 3.03

By John E. Hatch, Jr., and William M. Savelle

Langley Aeronautical Laboratory
Langley Field, Va.

NATIONAL ADVISORY COMMITTEE
FOR AERONAUTICS
WASHINGTON

January 27, 1953
Declassified June 24, 1958

NATIONAL ADVISORY COMMITTEE FOR AERONAUTICS

RESEARCH MEMORANDUM

SOME EFFECTS OF A SONIC JET EXHAUST ON THE LOADING
OVER A YAWED FIN AT A MACH NUMBER OF 3.03

By John E. Hatch, Jr., and William M. Savelle

SUMMARY

A preliminary experimental investigation has been made at a Mach number of 3.03 to determine the effects of a sonic jet exhaust on the loading over a yawed fin which overhangs the jet exit.

Pressure data for one spanwise fin station combined with schlieren photographs of the jet-exhaust flow indicated that up to an angle of yaw of 4° the loading on a rudder located over the aft 25 percent of the fin would reverse in sign as the jet-to-stream pressure ratio increased from the value for the no-flow condition to a value of 35. For the no-flow condition the loading would cause a rudder to aline itself with the free stream, but for jet-to-stream pressure ratios of 11 to 35 the loading would cause the rudder to turn into the free stream.

The effects of the jet exhaust in causing rudder reversal diminished with increasing angle of yaw above 4° until at $\psi = 8^\circ$ even the highest pressure ratios caused no rudder load reversal.

INTRODUCTION

Unpublished flight-test data obtained from the Douglas D-558-II airplane flown at Mach numbers above 1.1 at small angles of yaw have shown that the rudder hinge-moment coefficient reverses between power-off and power-on flight. For example, at a free-stream Mach number of 1.7 and an altitude of 60,000 feet, a rudder hinge-moment coefficient of -0.001 occurred for power-off flight, whereas for power-on flight a value of +0.012 was realized.

Jet-to-stream static-pressure ratios for which rudder hinge-moment reversal occurred on the D-558-II are shown in the following table:

Flight Mach number	Jet-exit Mach number	Altitude, ft	p_j/p_s
1.7	2.7	60,000	9
		76,000	20

At these high jet-to-stream pressure ratios it was believed that disturbances at the jet exit caused an unsymmetrical loading on the rudder which resulted in the reversal in rudder hinge-moment coefficient between power-off and power-on flight when the aircraft was in a yawed attitude.

In an attempt to demonstrate experimentally the type of loading which might develop at supersonic speeds on control surfaces placed near a jet exit, the present investigation was undertaken by the Gas Dynamics Branch of the Langley Laboratory. It should be pointed out that neither the model configuration nor the test conditions are the same as for the D-558-II airplane. The results of the present investigation, therefore, only serve to demonstrate an effect of a jet exhaust on the loading over a tail fin in a supersonic stream.

SYMBOLS

M	Mach number
p	static pressure
q	free-stream dynamic pressure
$\frac{\Delta p}{q}$	pressure coefficient, $\frac{p_l - p_s}{q}$
ψ	yaw angle

Subscripts:

s	in free stream
j	at jet exit
l	local value

APPARATUS

Figure 1 shows the model used in the investigation. The model was supported on the center line of a Mach number 3.03 blowdown jet by means of the two hollow struts. A fin was attached to the body of revolution in such a way as to overhang the jet exit.

Compressed air was supplied to the model through the hollow supporting struts and exhausted at a Mach number of 1.0 through the jet exit into the supersonic stream.

The model was yawed relative to the stream in increments of 2° up to an angle of yaw of 8° and the jet-to-stream static-pressure ratio was varied from the value for the no-flow condition to a value of 35 at each test angle of yaw.

As the jet-to-stream pressure ratio was varied the static pressures were measured at the station shown in figure 1. Pressure orifices were located on only one side of the fin; therefore, the model was yawed at positive and negative angles in order to simulate loading on the upstream and downstream side of the fin for any one angle of yaw.

The Reynolds number of the tests was 1.39×10^6 per inch.

PRECISION OF DATA

The estimated precision of the experimental data is given in the following table:

M_s	± 0.015
p_s , lb/sq in.	± 0.015
p_j , lb/sq in.	± 0.25
$\Delta p/q$	± 0.002
ψ , deg	± 0.10

As shown in figure 1, the fin lay in the plane of the hollow struts, and therefore the pressure measurements over the fin might have been affected by the wake behind the strut. The pressure measurements of the present tests were made 2 chord lengths behind the strut and approximately 0.20 strut semispans from the body center line. Reference 1 shows that the effects of the wake on static pressure and Mach number distribution were small at a corresponding station behind a rectangular wing at $M = 2.41$. It is not believed, therefore, that the wake behind the strut had any serious effects on the pressure measurements on the fin.

RESULTS AND DISCUSSION

In the discussion to follow a rudder will be assumed to occupy the aft 25 percent of the fin.

Figure 2(a) shows a typical flow pattern of a yawed jet exhausting at a high pressure ratio into a free stream of Mach number 3.03. On the lee side of the body the boundary layer thickens and separates upstream of the jet exit; the shock wave at the exit becomes a lambda shock with one leg forming upstream in the lower pressure region and one leg remaining at the lip of the exit. The formation of the lambda shock results in an unsymmetrical shock pattern surrounding the exit. If a fin is placed in the unsymmetrical flow field surrounding the exit (fig. 2(b)) the external shock wave at the jet exit will also move into the low-pressure region created on the lee side of the fin; whereas on the upstream or high-pressure side of the fin there will be no such movement of the shock wave from the jet exit. The movement of the shock wave onto the lee side of the fin results in higher pressures on the rudder surface behind the shock wave than exist on the corresponding area of the upstream side of the rudder, which would cause the rudder to turn into the free stream.

For the no-jet-flow condition no such strong external shock with its resulting high pressure is formed at the jet exit. The absence of the high pressures from the lee side of the rudder permits the rudder to align itself with the free stream.

The data for pressure distribution over the fin, obtained at the station indicated in figure 1, tend to substantiate the above reasoning as to how a jet exhaust can result in a reversal of rudder loading.

Pressure-distribution curves for the fin as the angle of yaw was varied from 2° to 8° are presented in figure 3. As the jet-to-stream pressure ratio is increased from the value for no jet flow to a value of 35, the development of the loading over the fin may be followed at each angle of yaw.

At 2° and 4° angle of yaw the pressure-distribution curves for the no-flow condition indicate that a rudder would tend to align itself with the free stream, but as the pressure ratio is increased the resultant loading reverses in sign and would cause the rudder to turn into the free stream. The limited pressure data, therefore, tend to show that the jet exhaust can cause a reversal of rudder loads between the no-flow or power-off condition and the power-on condition.

The effect of the jet exhaust in causing a reversal of rudder loads diminished with increasing angle of yaw above 4° until at $\psi = 8^\circ$

(fig. 3(d)) even the highest pressure ratio caused no rudder load reversal. At $\psi = 8^\circ$ the shock wave had moved upstream of the pressure orifices, which explains the absence of an abrupt pressure rise in the data of figure 3(d). Even at $\psi = 8^\circ$, however, the jet exhaust continued to influence the loading over the downstream side of the fin as the pressure ratio varied from no flow to 35. At the highest pressure ratio it should be noted that the loading on the upstream side of the fin was also influenced by the jet exhaust.

For the same pressure ratio, as the free-stream Mach number decreases the inclination of the external shock wave relative to the longitudinal axis of the jet exit increases. It would seem, therefore, that the problem of rudder reversal as a result of the jet exhaust is even more critical at low supersonic Mach numbers.

The movement of the shock wave upstream from the jet exit is to be expected for high jet-to-stream pressure ratios, especially when the free stream has low supersonic Mach numbers. Indeed, even from two-dimensional considerations, which do not take into account any viscous effects, it can be shown that for sufficiently high pressure ratios the shock wave at the exit will detach and move upstream to some position of equilibrium. At high pressure ratios the jet exhaust must expand when leaving the exit until the pressure just outside the jet boundary is equal to the pressure just inside the boundary. As the exhaust exit angle increases above a certain value, the stream cannot turn through the required deflection with an attached shock. The shock at the exit will then move upstream to some position of equilibrium. The movement of the shock wave from the jet exit will, of course, affect the loading over any control surfaces located close to the exit.

The high pressure ratios of the present tests are representative of those attainable by rocket-powered aircraft, whereas present-day aircraft powered by a turbojet or ram jet are not likely to attain such high pressure ratios. It is believed to be unlikely that supersonic aircraft operating at low jet-to-stream static-pressure ratios will encounter any significant rudder-reversal problems caused by the jet exhaust.

SUMMARY OF RESULTS

The results of an experimental investigation to determine the effects of a jet exhaust on the loading over a yawed fin in a free stream of Mach number 3.03 have shown the following:

1. Up to an angle of yaw of 4° the loading on a rudder located over the aft 25 percent of the fin reversed in sign as the jet-to-stream pressure ratio increased from the value for the no-flow condition to a value of 35. For the no-flow condition the loading would cause a rudder to align itself with the free stream, but for jet-to-stream pressure ratios of 11 to 35 the loading would cause the rudder to turn into the free stream.

2. The effects of the jet exhaust in causing rudder reversal diminished with increasing angle of yaw above 4° until at $\psi = 8^\circ$ even the highest pressure ratios caused no rudder-load reversal.

Langley Aeronautical Laboratory,
National Advisory Committee for Aeronautics,
Langley Field, Va.

REFERENCE

1. Adamson, D., and Boatright, William B.: Investigation of Downwash, Sidewash, and Mach Number Distribution Behind a Rectangular Wing at a Mach Number of 2.41. NACA RM L50G12, 1950.

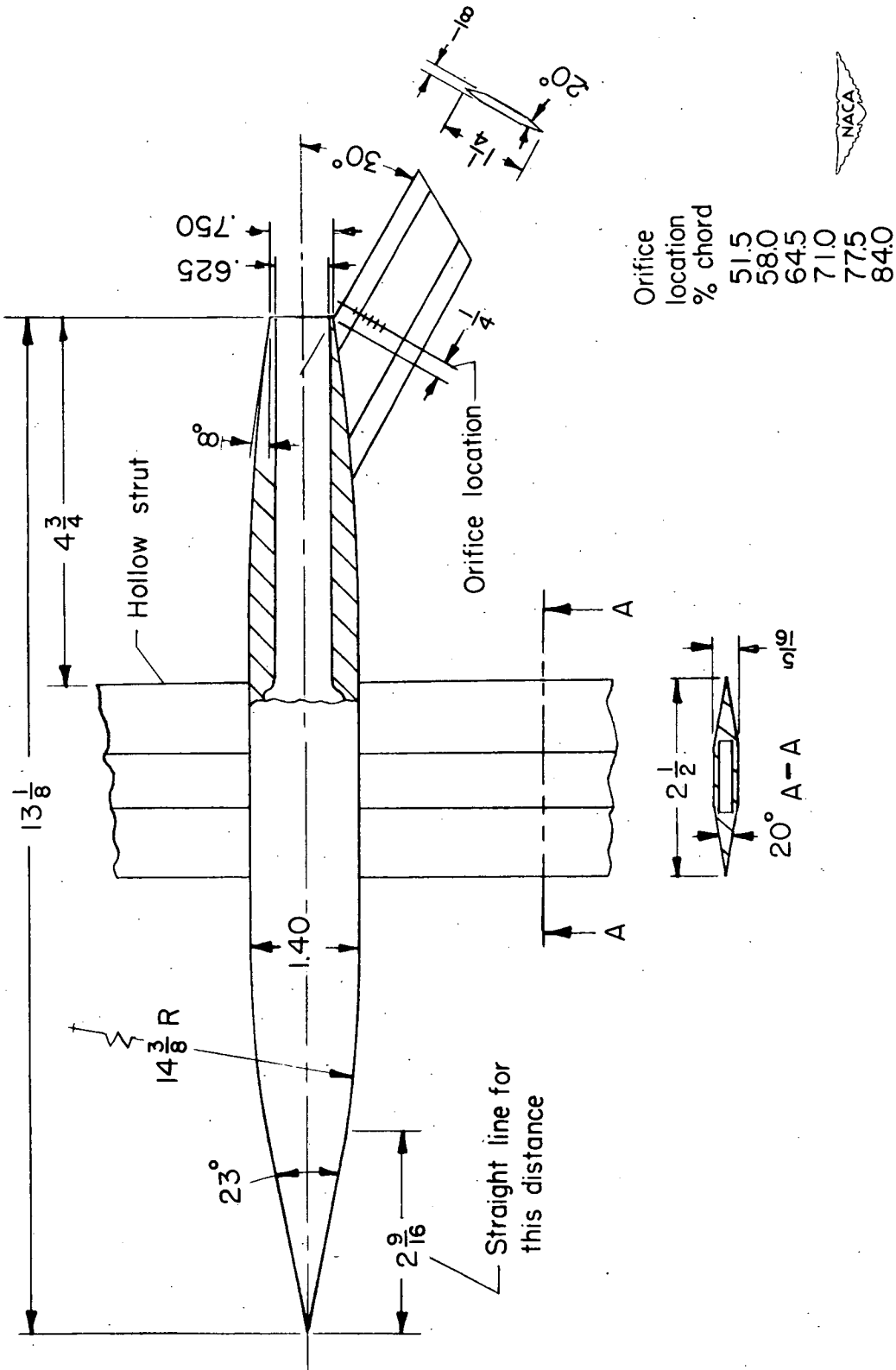
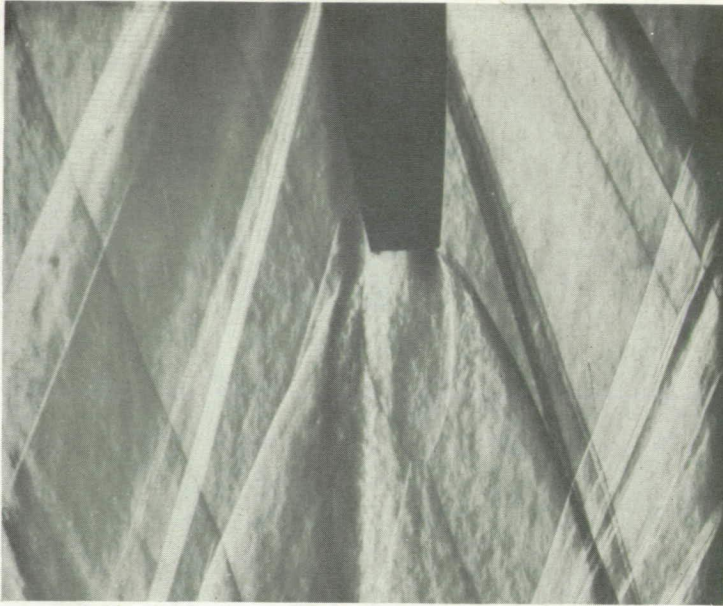
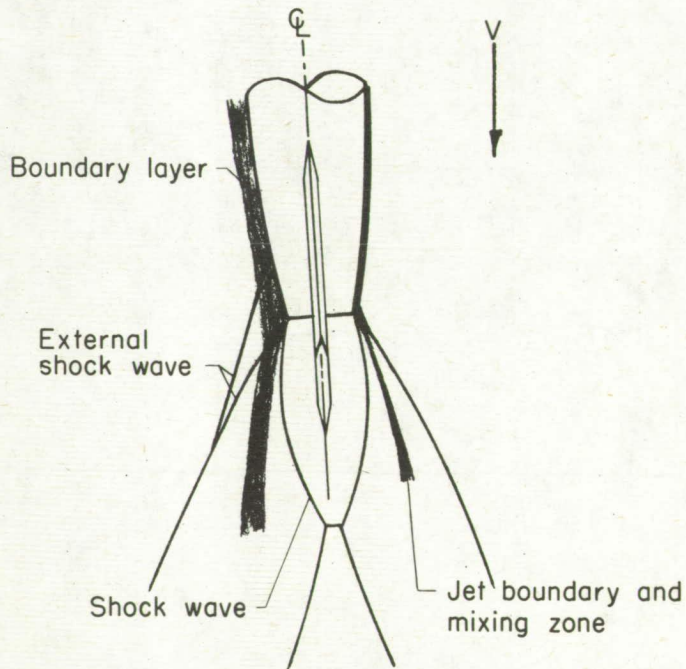

Figure 1.- Jet exhaust model (all dimensions in inches unless otherwise indicated).



(a) Representative schlieren photograph.



(b) Diagram of flow.

NACA

L-77040

Figure 2.- Flow about a yawed jet exhausting at a high jet-to-stream pressure ratio into a free stream of Mach number 3.03. $\psi = 4^\circ$.

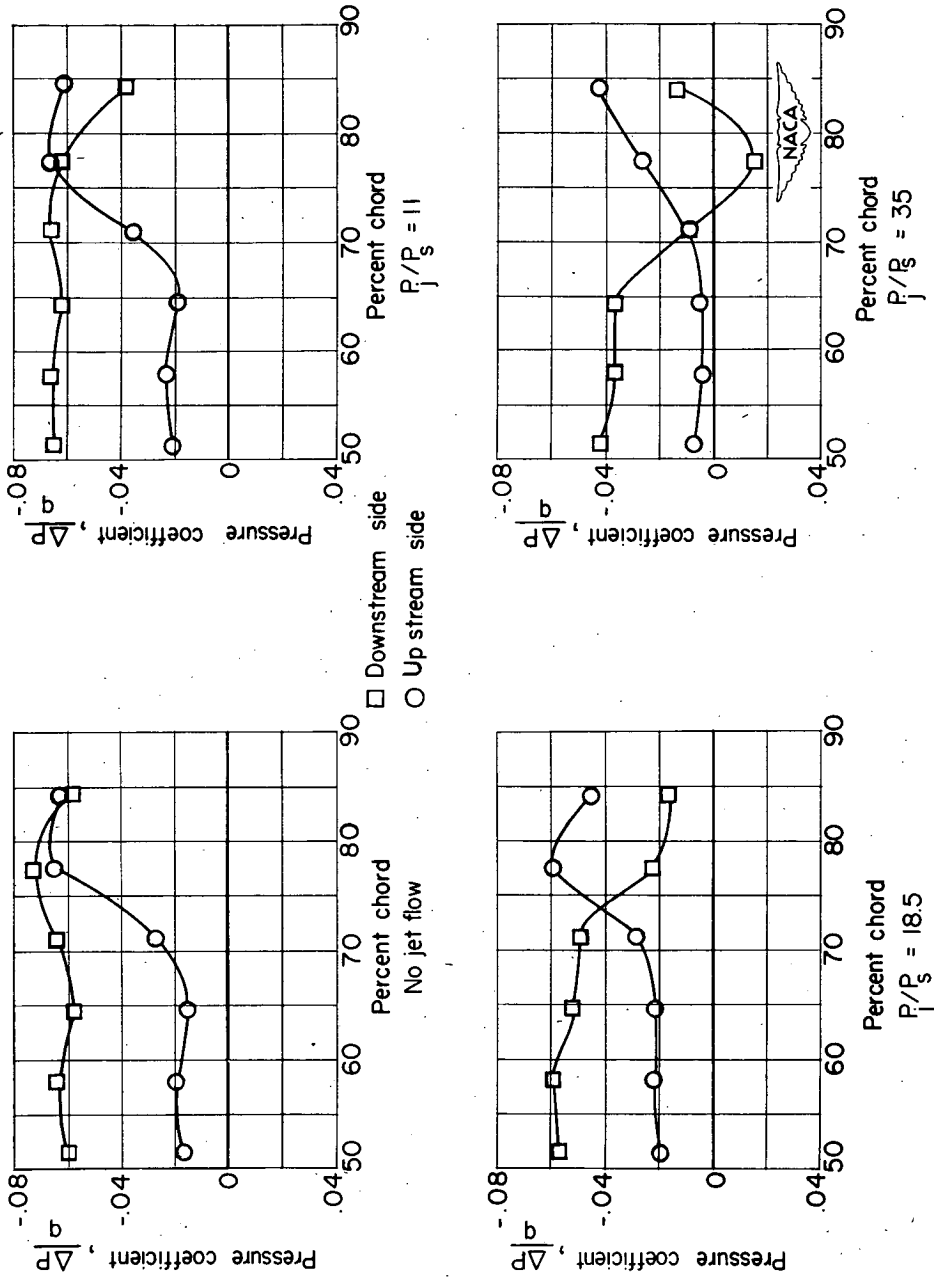

(a) $\psi = 2^\circ$.

Figure 3.- Effects of a jet exhaust on the pressure distribution over a rudder at $M = 3.03$.

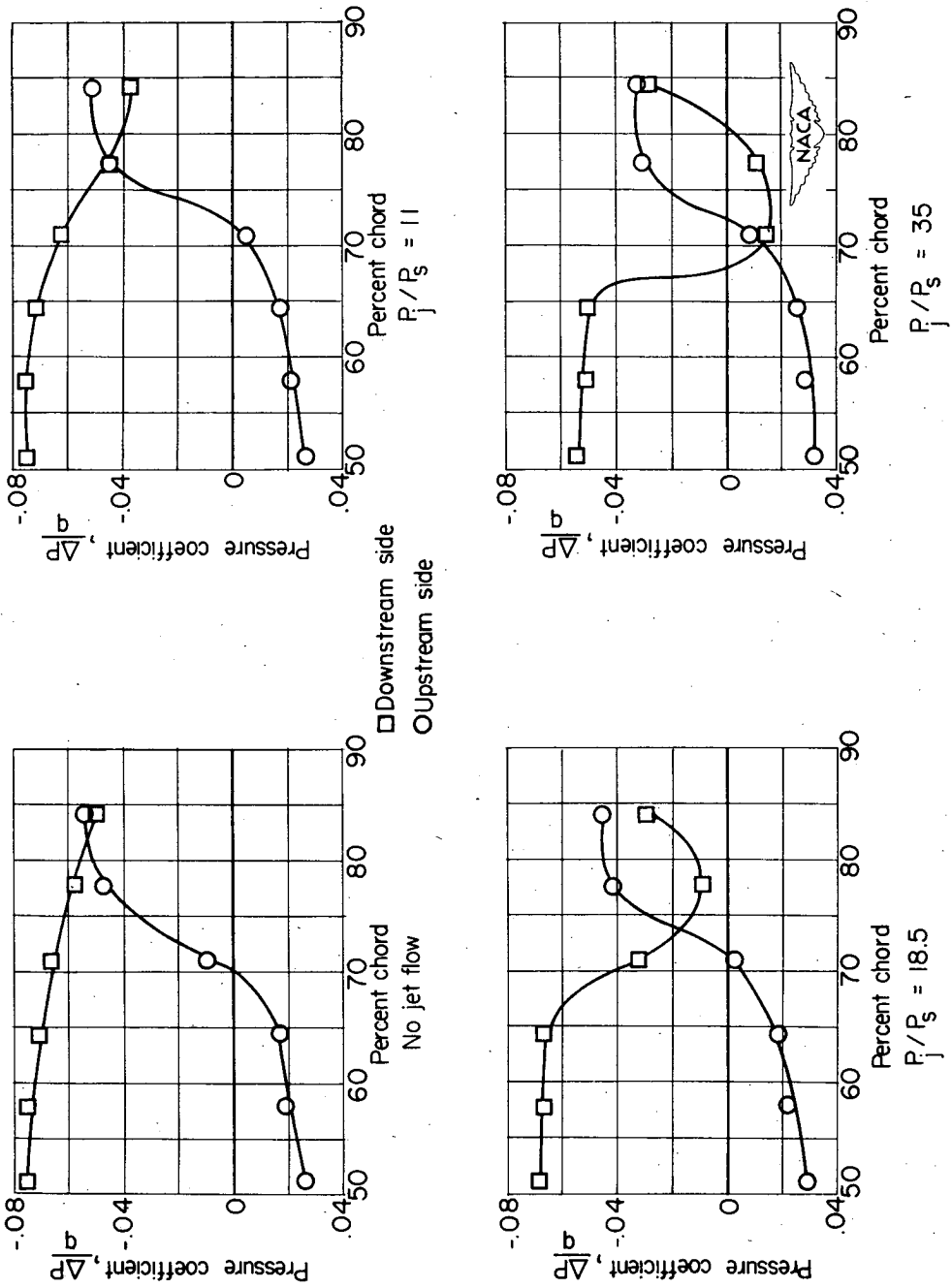

(b) $\psi = 4^\circ$.

Figure 3.-- Continued.

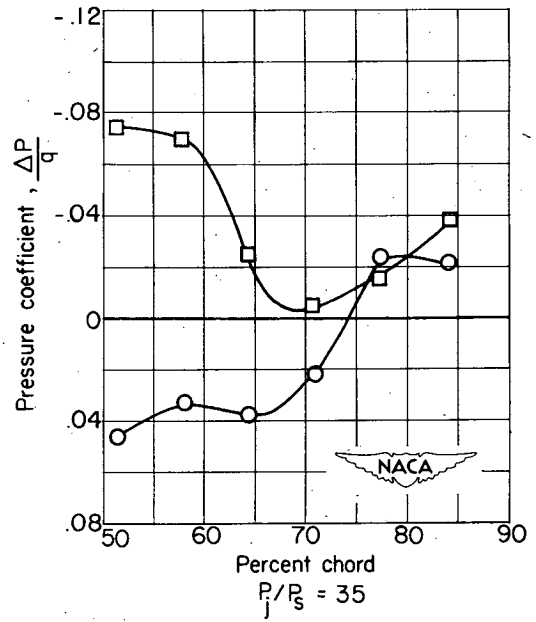
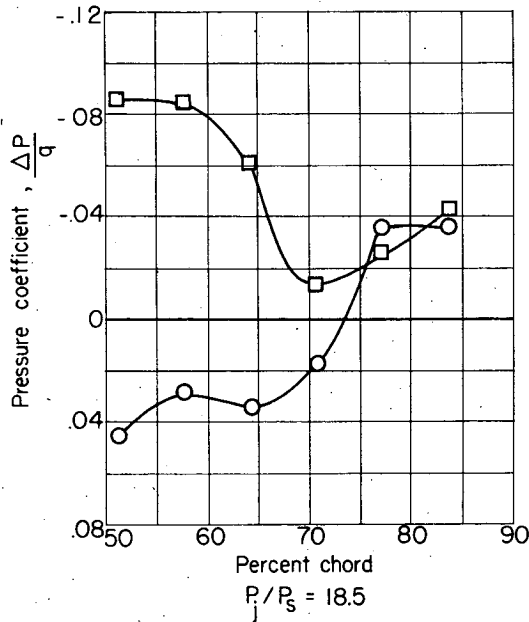
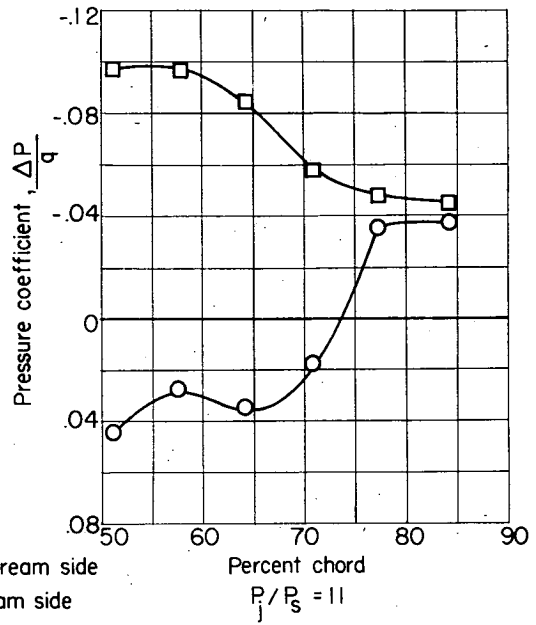
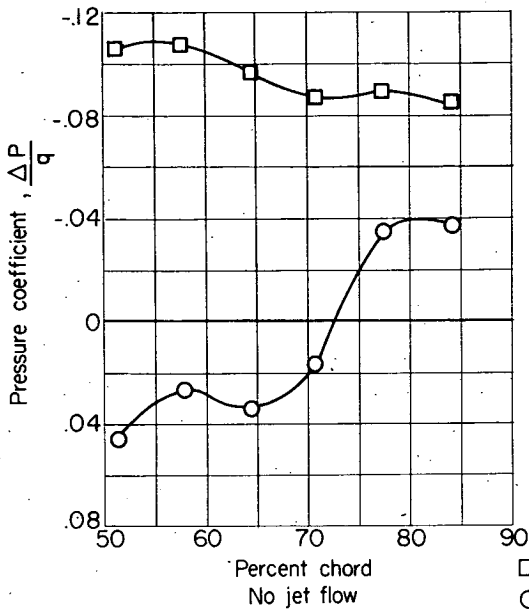

(c) $\psi = 6^\circ$.

Figure 3.- Continued.

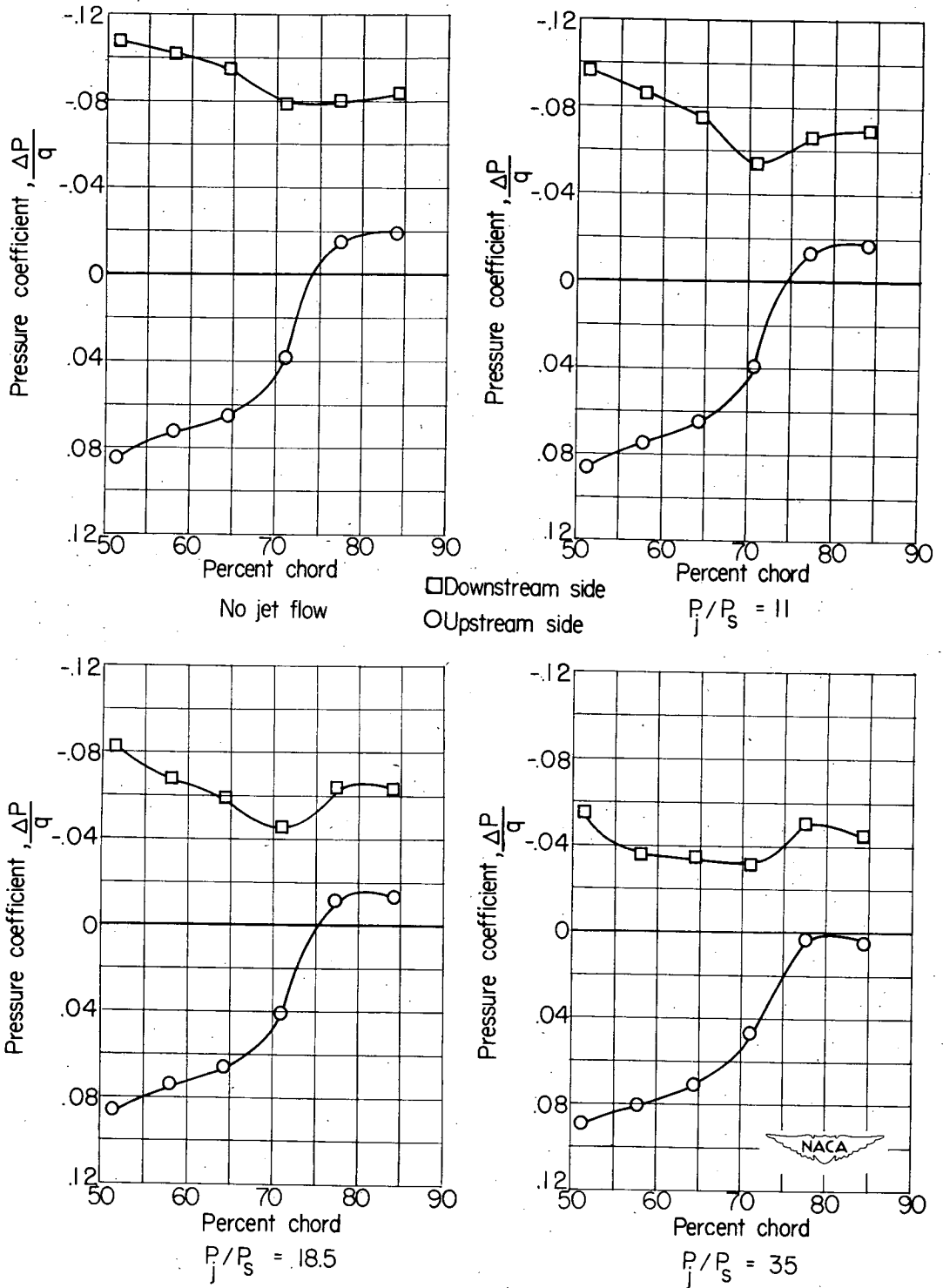

(d) $\psi = 8^\circ$.

Figure 3.- Concluded.