

CONFIDENTIAL

Copy
RM L52L29a

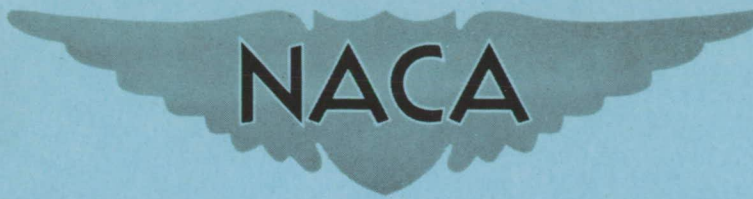

RESEARCH MEMORANDUM

THE EFFECTS OF FUSELAGE SIZE ON THE LOW-SPEED
LONGITUDINAL AERODYNAMIC CHARACTERISTICS OF
A THIN 60° DELTA WING WITH AND WITHOUT
A DOUBLE SLOTTED FLAP

By John M. Riebe

Langley Aeronautical Laboratory
Langley Field, Va.

CLASSIFICATION CHANGED TO UNCLASSIFIED
AUTHORITY: NACA RESEARCH ABSTRACT NO. 94
DATE: JAN 11, 1956
WEL

CLASSIFIED DOCUMENT

This material contains information affecting the National Defense of the United States within the meaning of the espionage laws, Title 18, U.S.C., Secs. 793 and 794, the transmission or revelation of which in any manner to an unauthorized person is prohibited by law.

NATIONAL ADVISORY COMMITTEE FOR AERONAUTICS

WASHINGTON

February 2, 1953

CONFIDENTIAL

NATIONAL ADVISORY COMMITTEE FOR AERONAUTICS

RESEARCH MEMORANDUM

THE EFFECTS OF FUSELAGE SIZE ON THE LOW-SPEED
LONGITUDINAL AERODYNAMIC CHARACTERISTICS OF
A THIN 60° DELTA WING WITH AND WITHOUT
A DOUBLE SLOTTED FLAP

By John M. Riebe

SUMMARY

An investigation was made in the Langley 300 MPH 7- by 10-foot tunnel to determine the effects of fuselage size on the low-speed longitudinal aerodynamic characteristics of a thin delta wing with and without a double slotted flap extending from the fuselages to 67 percent of the wing span. The wing was a flat plate with beveled leading and trailing edges and had a maximum thickness ratio of 0.045 and 60° sweepback of the leading edge. The fuselages which consisted of ogival noses attached to circular cylinders had maximum diameters of 0.094, 0.146, 0.219, and 0.292 wing span.

The maximum lift coefficient was reduced from 1.40 to 1.01 for the flap-retracted condition and from 1.71 to 1.16 with the flap deflected 54° when the fuselage-diameter-wing-span ratio was increased from 0.094 to 0.292. The corresponding increase in fuselage-diameter-wing-span ratio resulted in a reduction of the lift coefficient at 0° angle of attack from 0.87 to 0.58 with the double slotted flap deflected 54° . A slight reduction of lift-curve slope and a decrease in longitudinal stability corresponding to a forward aerodynamic-center shift of 7 percent mean aerodynamic chord, flaps up, and 18 percent mean aerodynamic chord, flaps deflected, occurred with the fuselage-diameter-wing-span ratio increase. Estimates of the variation with fuselage-diameter-wing-span ratio of the lift-curve slope and aerodynamic center for the flaps-undeflected condition and the increment of lift from double slotted flap deflection at 0° angle of attack are in good agreement with the experimental data.

INTRODUCTION

The feasibility of using double slotted flaps as a means of reducing the high landing angle of attack and relatively high landing speeds of airplanes with thin delta-wing plan forms is currently being investigated by the National Advisory Committee for Aeronautics. References 1 and 2 have indicated that a double slotted flap on a delta-wing airplane should result in considerable reduction in the angle of attack necessary to obtain a given lift coefficient and produce some increase in maximum lift coefficient; however, these investigations have been made with a small fuselage that was used primarily to house a strain-gage balance. The present report gives the results of an investigation to determine the aerodynamic characteristics of one of the optimum double-slotted-flap configurations of reference 2 with larger fuselages (fuselage-diameter-wing-span ratios ranged from 0.094 to 0.292). Also included are the effects of fuselage-diameter-wing-span ratio on the delta-wing characteristics with flaps retracted. Theoretical estimates of the variation of some of the aerodynamic characteristics with fuselage-diameter-wing-span ratio are compared with the experimental data.

COEFFICIENTS AND SYMBOLS

The results of the tests are presented as standard NACA coefficients of forces and moments about the stability axes. The positive directions of forces and moments are shown in figure 1. Pitching-moment coefficients are given about the wing 25-percent-mean-aerodynamic-chord point shown in figure 2. The coefficients and symbols are defined as follows:

C_L	lift coefficient, L/qS
C_D	drag coefficient, D/qS
C_m	pitching-moment coefficient, $M/qS\bar{c}$
L	lift, lb
D	drag, lb
M	pitching moment, ft-lb
q	free-stream dynamic pressure, $\frac{1}{2}\rho V^2$, lb/sq ft
S	wing area, 6.93 sq ft
\bar{c}	wing mean aerodynamic chord, 2.31 ft, $\frac{2}{S} \int_0^{b/2} c^2 dy$

b	wing span, 4.00 ft
V	free-stream velocity, ft/sec
d	fuselage diameter at wing upper-surface lip
α	angle of attack of wing, deg
c	local wing chord, ft
y	lateral distance from plane of symmetry
δ_f	flap deflection measured in a plane perpendicular to hinge line, deg

Subscripts:

w wing alone

$$C_{L\alpha} = \frac{\partial C_L}{\partial \alpha}$$

max maximum

MODEL AND APPARATUS

The model was tested in the Langley 300 MPH 7- by 10-foot tunnel by utilizing a sting-support system (fig. 3) and an electrical strain-gage balance.

The basic wing, which was the same as that of references 1 and 2, had a 60° apex angle, a taper ratio of 0, an aspect ratio of 2.31, and a hexagonal airfoil section with thickness ratio varying from 1.5 percent chord at the root to 4.5 percent chord at $0.67b/2$ (15.98 inches from root). The geometric characteristics of the various fuselages that were tested on the model with flaps up and down are given in figure 2(a) and table I. The fuselages were constructed of wood noses attached to sheet aluminum cylinders. The double-slotted-flap arrangement tested (fig. 4) was one of the optimum configurations with regard to lift effectiveness at both low and high angles of attack determined in reference 2. The inboard end of the flaps fitted flush against the various fuselages with the exception of the fuselage with the smallest diameter. This fitting was accomplished by extending the original span flap into the fuselage cylinders through slots and fairing the slot gaps with masking tape. Further details of wing and flap construction are presented in reference 2.

TESTS

The tests were made in the Langley 300 MPH 7- by 10-foot tunnel at a dynamic pressure of approximately 25.0 pounds per square foot corresponding to an airspeed of about 100 miles an hour. Reynolds number for this airspeed, based on the wing mean aerodynamic chord (2.31 ft) was approximately 2.1×10^6 . The corresponding Mach number was 0.13.

CORRECTIONS

The approximate jet-boundary corrections applied to the data were obtained from methods outlined in reference 3. A correction has been applied to the angle of attack to account for the deflection of the support strut under load. Blocking corrections have been applied to the model with the various fuselages according to the methods of reference 4. Buoyancy corrections have been applied to the model with the various fuselages to account for a longitudinal static-pressure gradient in the tunnel.

RESULTS AND DISCUSSION

The lift, drag, and pitching-moment characteristics of the delta wing with the various fuselages are given in figures 5 and 6 for the conditions with double slotted flaps at deflections of 0° and 54° , respectively. The aerodynamic characteristics, as determined from an unpublished investigation, for three fuselages alone, almost identical to the fuselages of the models of the present investigation (see table I), are presented in figure 7; the coefficients are based on the geometry of the plain wing. The wing-fuselage lift coefficient and lift-curve slope as a function of fuselage-diameter-wing-span ratio are given in figures 8 and 9, respectively. The variation with fuselage-diameter-wing-span ratio of the aerodynamic-center position of the fuselage alone and wing-fuselage combination is presented in figure 10.

Flaps Retracted

Increasing the fuselage-diameter-wing-span ratio with flaps at 0° resulted in only small change of lift coefficient at low angles of attack, large reductions in maximum lift coefficient (defined as first lift coefficient where the slope of the lift curve became zero), and some reductions in the angle of attack at which maximum lift occurred (figs. 5 and 8). Increasing fuselage diameter from about 9 percent of the span

to 29 percent of the span reduced $C_{L_{max}}$ from about 1.40 to about 1.01. The angle of attack at which $C_{L_{max}}$ occurred decreased from 35° for the small fuselage configuration to about 27° for the large fuselage configuration (fig. 5). As the fuselage size increased the lift curve near maximum lift for the delta wing became flatter. The "flat top" lift curve of the large-fuselage-diameter configuration was typical of other models having large fuselages and low-aspect-ratio wings and resulted from the lift load on the fuselage continuing to increase at angles of attack beyond that at which the wing stalled. As would be expected, increased d/b also resulted in an increase of drag coefficient at a given lift coefficient, (fig. 5).

Increasing the size of the fuselage with respect to the wing resulted in a loss in C_{L_α} with the flaps retracted (fig. 9). The variation of $C_{L_\alpha}/C_{L_{\alpha_w}}$ with d/b agrees very well with the theoretical variation of reference 5. The value of $C_{L_{\alpha_w}}$ in the ratio $C_{L_\alpha}/C_{L_{\alpha_w}}$ was obtained by extrapolating the experimental C_{L_α} data to zero d/b . The theory of reference 5 applies mainly to narrow triangular wings and does not predict accurately the absolute values of $C_{L_{\alpha_w}}$ for the wing of the present tests. Comparison between theory and experiment was therefore made in terms of the ratio $C_{L_\alpha}/C_{L_{\alpha_w}}$. The variation of C_{L_α} for the fuselage alone is satisfactorily predicted by the theory of reference 5 (fig. 9).

In order to show the breakdown of total lift of the wing-body combination the component parts and interferences were estimated for the wing-fuselage combination of $\frac{d}{b} = 0.292$ by a method somewhat similar to that of reference 6. The breakdown of C_{L_α} and references 6 to 12 used in estimating the lift of the component parts is as follows:

Component	Reference for theory	Theory		Experimental
		C_{L_α}	Percent total	
Fuselage alone	9 and 12	0.0052	11.1	0.0047
Wing upwash on fuselage	9 and 12	0.0008	1.7	-----
Wing alone outboard of fuselage	8	0.0258	55.0	-----
Fuselage upwash on wing outboard of fuselage	6, 7, 8, and 10	0.0047	10.0	-----
Wing load carried over fuselage	6 and 11	0.0104	22.2	-----
Total		0.0469	100	.0430

The result of this breakdown ($C_{L_{\alpha}} = 0.0469$) compares favorably with the method of reference 5 ($C_{L_{\alpha}} = 0.044$ when the ratio $C_{L_{\alpha}}/C_{L_{\alpha_w}}$ is multiplied by the experimental value of $C_{L_{\alpha_w}}$) and with the experimental value ($C_{L_{\alpha}} = 0.0430$).

The longitudinal stability of the wing-fuselage combination, flaps retracted, was reduced with increased values of d/b (figs. 5 and 10). The aerodynamic center shifted forward from $0.36\bar{c}$ for $\frac{d}{b} = 0.09$ to $0.29\bar{c}$ for $\frac{d}{b} = 0.292$. This change of aerodynamic center with d/b is in very good agreement with the change estimated by the method of reference 5. If the results of reference 5 are modified by using the aerodynamic center of the wing alone predicted by reference 8, the agreement in absolute value with experimental data is very good (fig. 10). This modification can be shown in the following equation from reference 5. The first term C_{m_w}/C_{L_w} which is the aerodynamic center for the wing alone was replaced by the value of the aerodynamic center determined from reference 8.

$$\text{a.c.} = \frac{C_{m_w}}{C_{L_w}} \left[\frac{1 - 4\left(\frac{d}{b}\right)^3 + 3\left(\frac{d}{b}\right)^4 + \frac{6B_m l}{\pi b 2\bar{c}}}{1 - \left(\frac{d}{b}\right)^2 + \left(\frac{d}{b}\right)^4} \right]$$

The term B_m is the mean cross-sectional area of fuselage ahead of wing apex (volume/length) and l is the length of fuselage ahead of wing apex. The second term of the equation represents the modifying effect of the fuselage on the wing characteristics.

The variation of aerodynamic center for the fuselage alone (fig. 10) agrees with the trend predicted by reference 5 but does not show agreement in absolute value.

Flaps Deflected

Considerable reduction in maximum lift coefficient and in increment of lift coefficient at $\alpha = 0^\circ$ occurred with increased d/b ratio for the condition with double slotted flap deflected 54° (fig. 8). The maximum lift coefficient was reduced from 1.71 for a d/b ratio of 0.09 to 1.16 for a d/b ratio of 0.29. The reduction in lift increment at 0° angle of attack was about half that of the maximum lift coefficient reduction for the same increase in d/b ratio (C_L at 0° reduced from 0.87 at d/b of 0.09 to 0.58 at a d/b of 0.29). An estimated variation

of the lift-coefficient increment at an angle of attack of 0° for the double-slotted-flap-deflected configuration is shown by the dashed line of figure 8. This variation was obtained by the use of reference 7 which presents lift effectiveness for flaps of various spans. The experimental value of flap lift increment for the $\frac{d}{b} = 0.09$ configuration was used as the basis in estimating the loss of lift increment with reduced flap span resulting from increased fuselage diameter.

The lift curves for the flap-deflected condition were generally nonlinear and the loss of $C_{L\alpha}$ with d/b was larger than that for the flap-retracted condition (figs. 5 and 6). As would be expected and similar to the condition with flaps undeflected, increased d/b resulted in higher drag at a given lift coefficient.

The changes in longitudinal stability with fuselage-diameter-wing-span ratio increase were larger with flaps deflected than with the flap retracted. The aerodynamic center shifted from a position about $0.49\bar{c}$ for the $0.09d/b$ fuselage-diameter-wing-span ratio configuration to about $0.31\bar{c}$ for the configuration with d/b of 0.29; this aerodynamic-center shift was almost $2\frac{1}{2}$ times that for the condition with flaps retracted (fig. 10). The large diving-moment increment with deflection of the double slotted flaps (figs. 5 and 6) is typical of that found in two-dimensional investigation of double slotted flaps on thicker wing sections (ref. 13). As would be expected, reducing the extent of the flap span by increasing the d/b ratio resulted in a smaller diving-moment increment at constant angle of attack (figs. 5 and 6) and smaller shift of the aerodynamic center (fig. 10).

CONCLUSIONS

The results of a low-speed wind-tunnel investigation to determine the effects of fuselage-diameter-wing-span ratio on the lift and longitudinal stability characteristics of a thin 60° delta wing with and without a double slotted flap extending from the fuselages to 67 percent of the wing span indicated the following conclusions:

1. The maximum lift coefficient was reduced from 1.40 to 1.01 for the flap-retracted conditions and from 1.71 to 1.16 for the flap deflected 54° when the fuselage-diameter-wing-span ratio was increased from 0.09 to 0.29.
2. The increment of lift from double-slotted-flap deflection at 0° angle of attack was reduced from 0.87 for a fuselage-diameter-wing-span ratio of 0.09 to 0.58 for a fuselage-diameter-wing-span ratio of 0.29.

3. Increased fuselage-diameter-wing-span ratio resulted in only a slight reduction in lift-curve slope with flaps undeflected.

4. Increased fuselage-diameter-wing-span ratio from 0.09 to 0.29 resulted in a decrease in longitudinal stability corresponding to a forward shift of 7 percent mean aerodynamic chord, flaps up, and 18 percent mean aerodynamic chord, flaps deflected.

5. Estimates of the variation with fuselage-diameter-wing-span ratio of the lift-curve slope for flaps undeflected and the increment of lift from double-slotted-flap deflection at an angle of attack of 0° are in good agreement with the experimental data.

Langley Aeronautical Laboratory,
National Advisory Committee for Aeronautics,
Langley Field, Va.

REFERENCES

1. MacLeod, Richard G.: A Preliminary Low-Speed Wind-Tunnel Investigation of a Thin Delta Wing Equipped With a Double and a Single Slotted Flap. NACA RM L51J26, 1952.
2. Riebe, John M., and MacLeod, Richard G.: Low-Speed Wind-Tunnel Investigation of a Thin 60° Delta Wing With Double Slotted, Single Slotted, Plain, and Split Flaps. NACA RM L52J29, 1952.
3. Gillis, Clarence L., Polhamus, Edward C., and Gray, Joseph L., Jr.: Charts for Determining Jet-Boundary Corrections for Complete Models in 7- by 10-Foot Closed Rectangular Wind Tunnels. NACA ARR L5G31, 1945.
4. Herriot, John G.: Blockage Corrections for Three-Dimensional-Flow Closed-Throat Wind Tunnels, With Consideration of the Effect of Compressibility. NACA Rep. 995, 1950. (Supersedes NACA RM A7B28.)
5. Spreiter, John R.: The Aerodynamic Forces on Slender Plane- and Cruciform-Wing and Body Combinations. NACA Rep. 962, 1950. (Supersedes NACA TN's 1897 and 1662.)
6. Hopkins, Edward J., and Carel, Hubert C.: Experimental and Theoretical Study of the Effects of Body Size on the Aerodynamic Characteristics of an Aspect Ratio 3.0 Wing-Body Combination. NACA RM A51G24, 1951.
7. DeYoung, John: Theoretical Symmetric Span Loading Due to Flap Deflection for Wings of Arbitrary Plan Form at Subsonic Speeds. NACA TN 2278, 1951.

8. DeYoung, John, and Harper, Charles W.: Theoretical Symmetric Span Loading at Subsonic Speeds for Wings Having Arbitrary Plan Form. NACA Rep. 921, 1948.
9. McLaughlin, Milton D.: Method of Estimating the Stick-Fixed Longitudinal Stability of Wing-Fuselage Configurations Having Unswept or Swept Wings. NACA RM L51J23, 1952.
10. Glauert, H.: The Elements of Aerofoil and Airscrew Theory, Cambridge Univ. Press, reprint of 1942.
11. Wieselberger, C.: Airplane Body (Non-Lifting System) Drag and Influence on Lifting System. Vol. IV of Aerodynamic Theory, div. K, W. F. Durand, ed., Julius Springer (Berlin), 1935, pp. 152-157.
12. Multhopp, H.: Aerodynamics of the Fuselage. NACA TM 1036, 1942.

13. Purser, Paul E., Fischel, Jack, and Riebe, John M.: Wind-Tunnel Investigation of an NACA 23012 Airfoil With a 0.30-Airfoil-Chord Double Slotted Flap. NACA ARR 3L10, 1943.

TABLE I
 PHYSICAL CHARACTERISTICS OF THE VARIOUS FUSELAGES TESTED ON THE DELTA WING

Diameter wing span	Maximum diameter, in.	Maximum cross-section area, sq in.	Length, in.	Length/ diameter	Volume, cu in.	Length, in. (a)	Volume, cu in. (a)	Length/ diameter (a)
0.094	4.5	15.92	35.60	7.91	-----	-----	-----	-----
.146	7.0	38.48	52.07	7.44	1837	49.00	1718	7.00
.219	10.5	86.60	57.32	5.46	4397	52.50	3977	5.00
.292	14.0	153.94	62.57	4.47	8290	63.00	8356	4.50

NACA

^aCharacteristics of fuselages tested without wing.

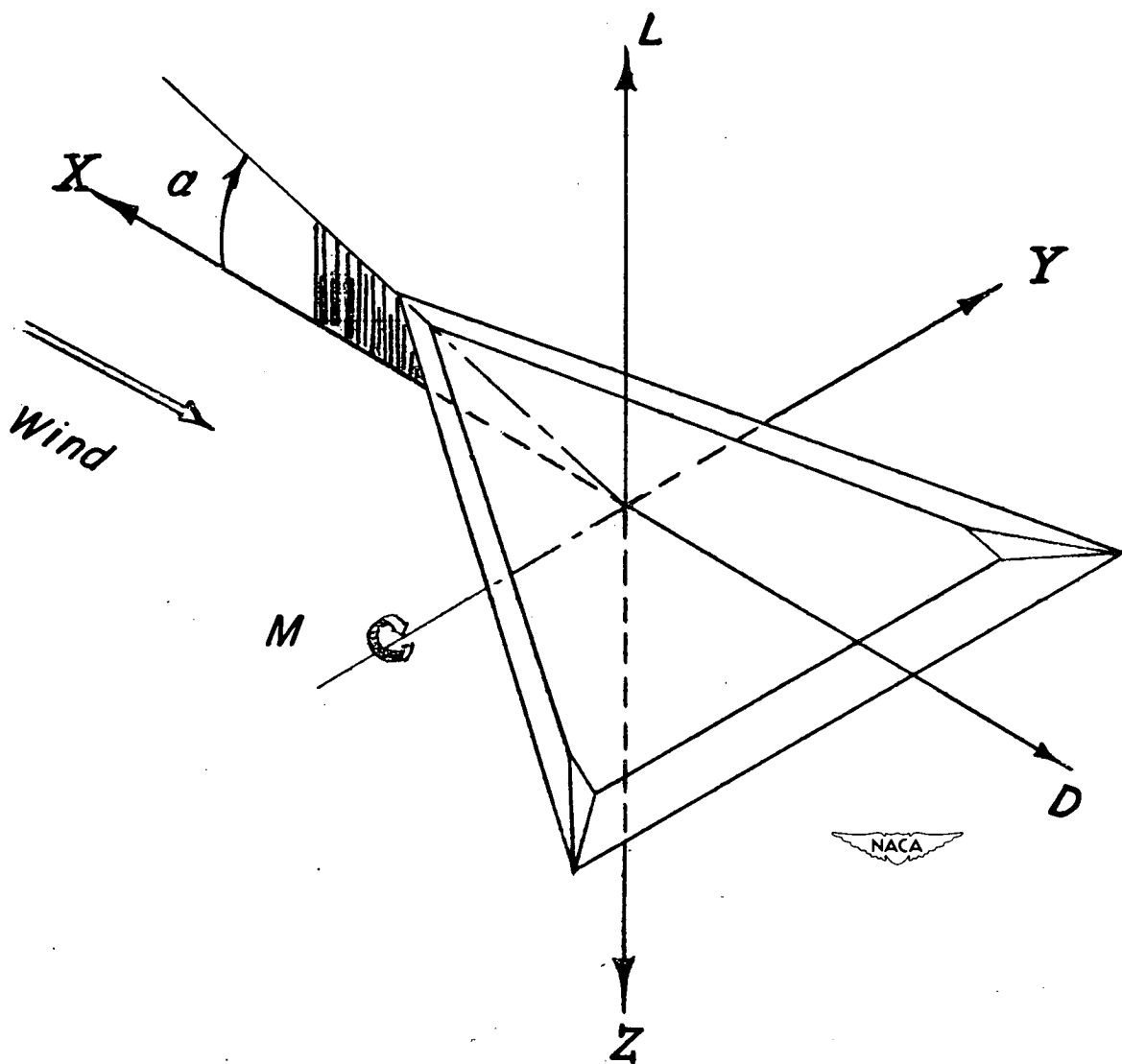
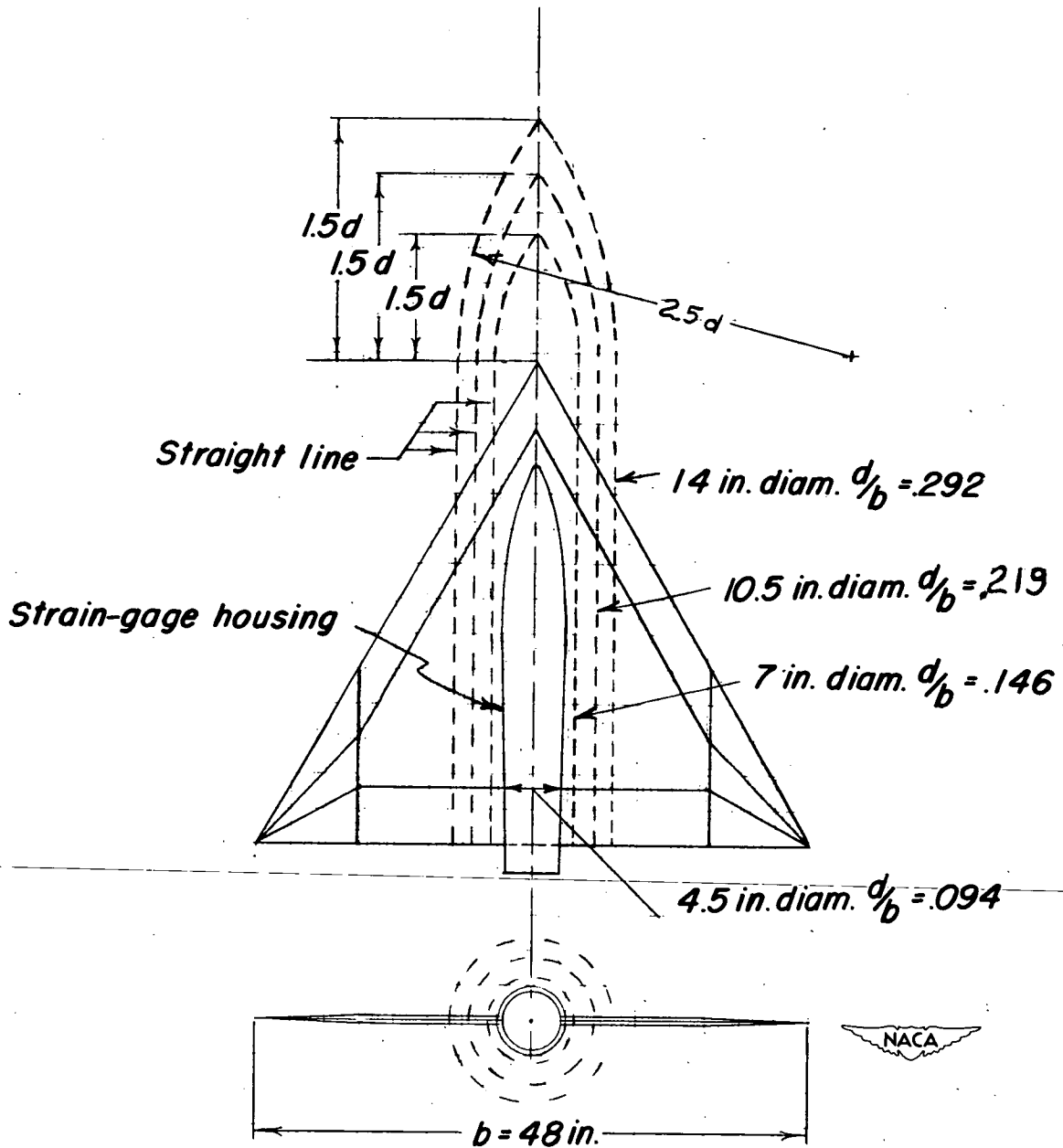
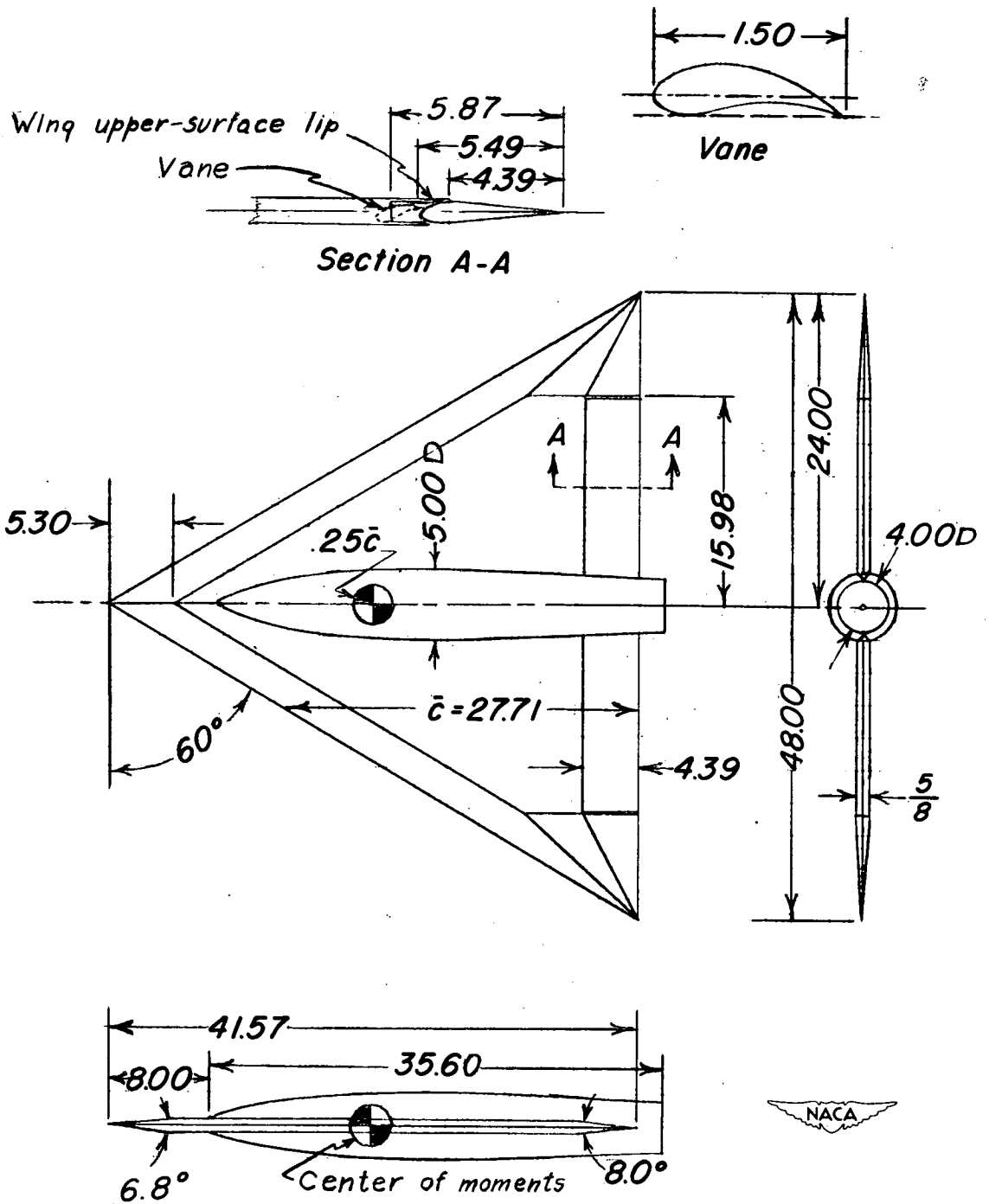

Figure 1.- System of stability axes. Positive values of forces, moments, and angles are indicated by arrows.



(a) Fuselages.

Figure 2.- General arrangement of the fuselages and the thin delta wing.
All dimensions are in inches.



(b) Wing.

Figure 2.- Concluded.

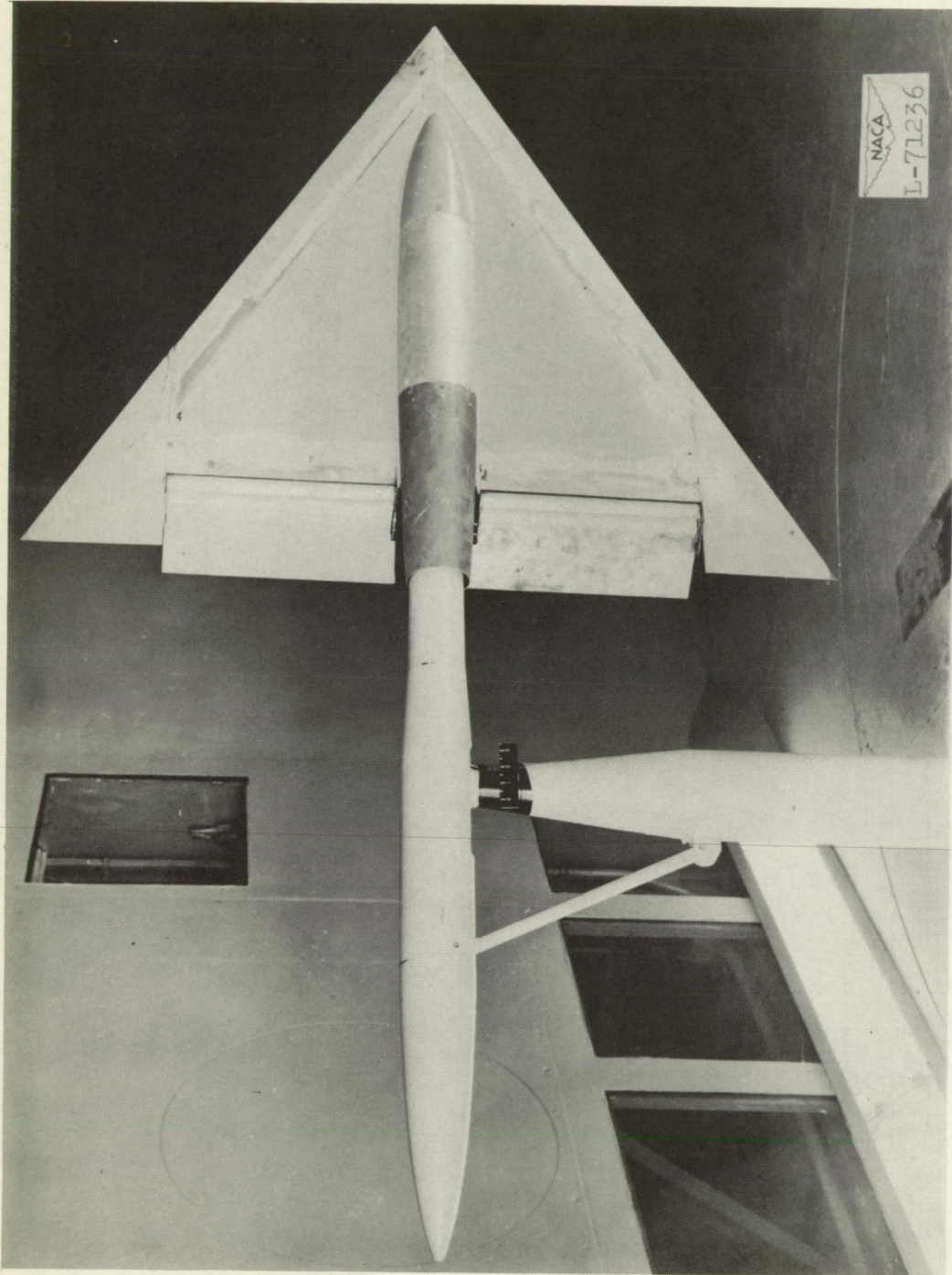

Figure 3.- The 60° delta-wing model mounted in the Langley 300 MPH 7- by 10-foot tunnel.

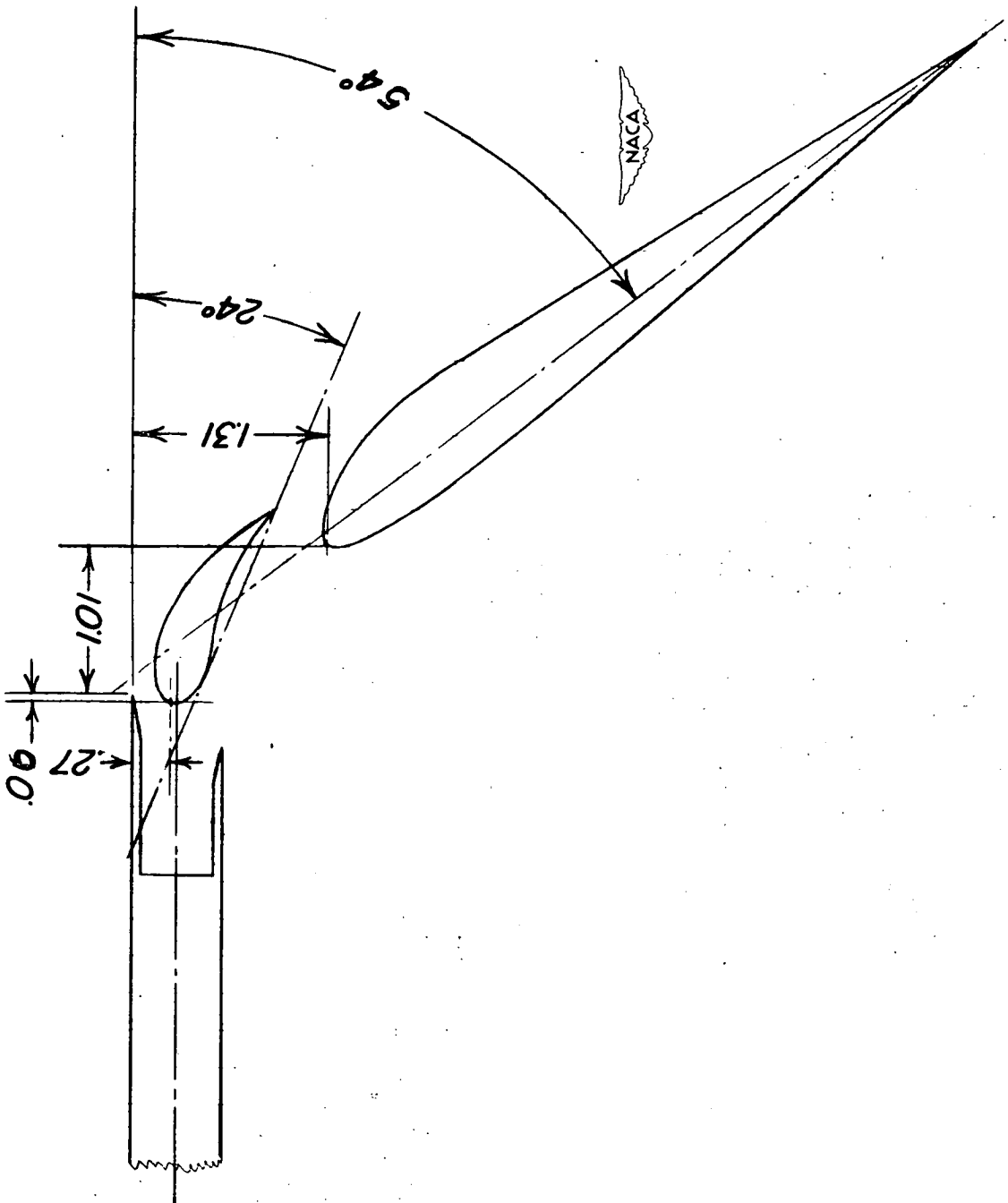

Figure 4.- The double-slotted flap configuration tested on the thin delta wing. All dimensions are in inches.

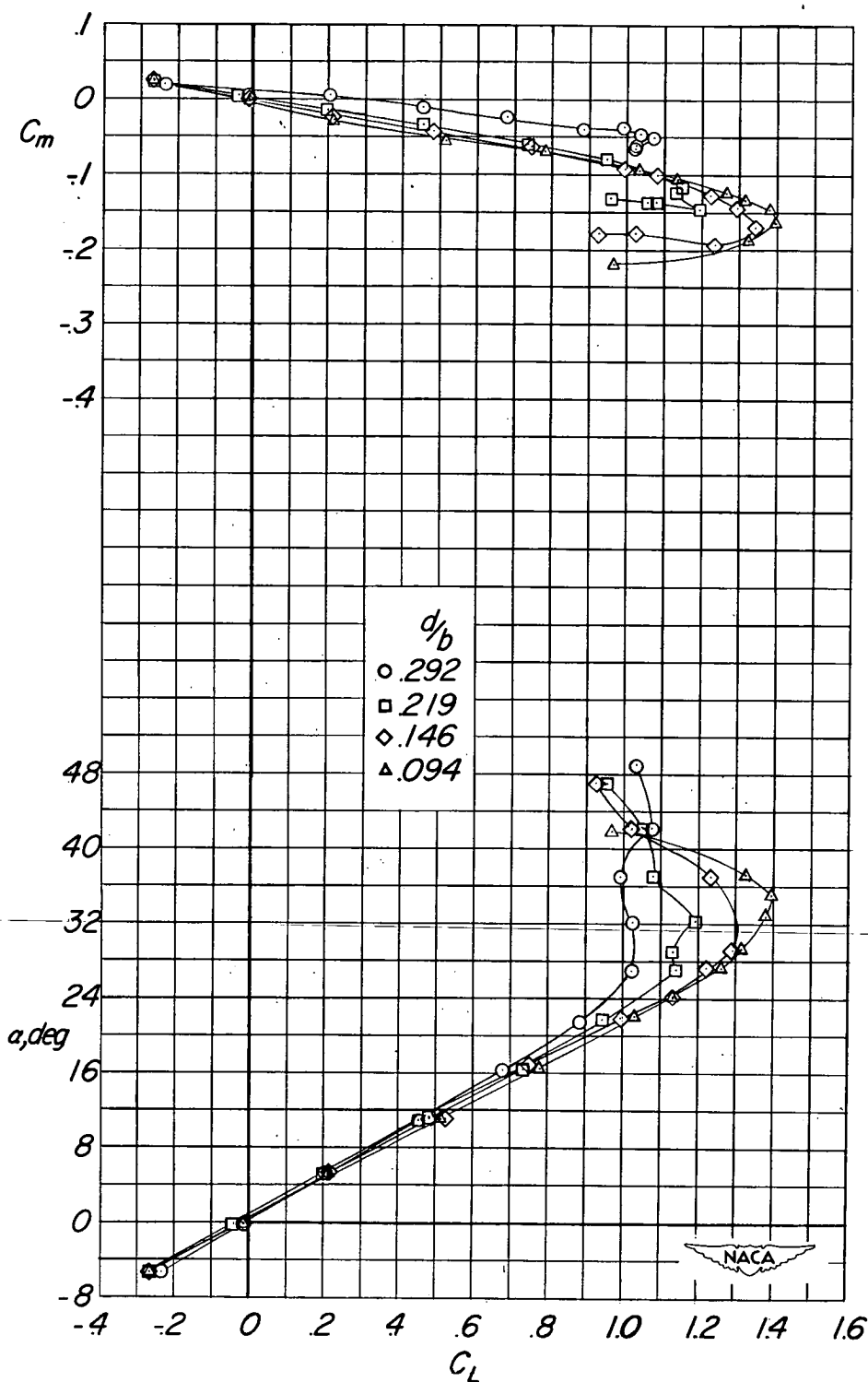

Figure 5.- Longitudinal aerodynamic characteristics of the thin 60° delta wing with fuselages of various diameters. $\delta_f = 0^\circ$.

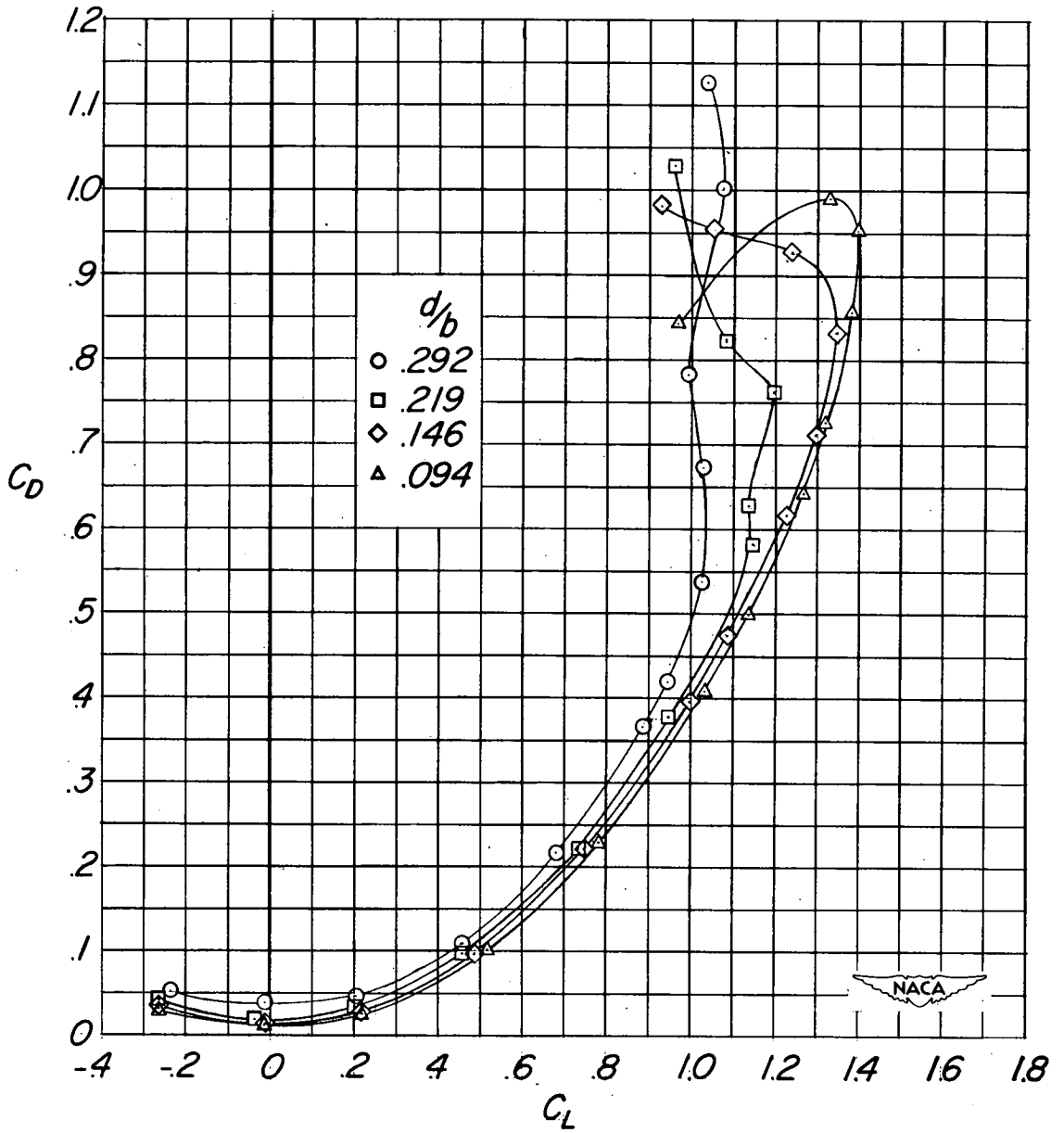

Figure 5.- Concluded.

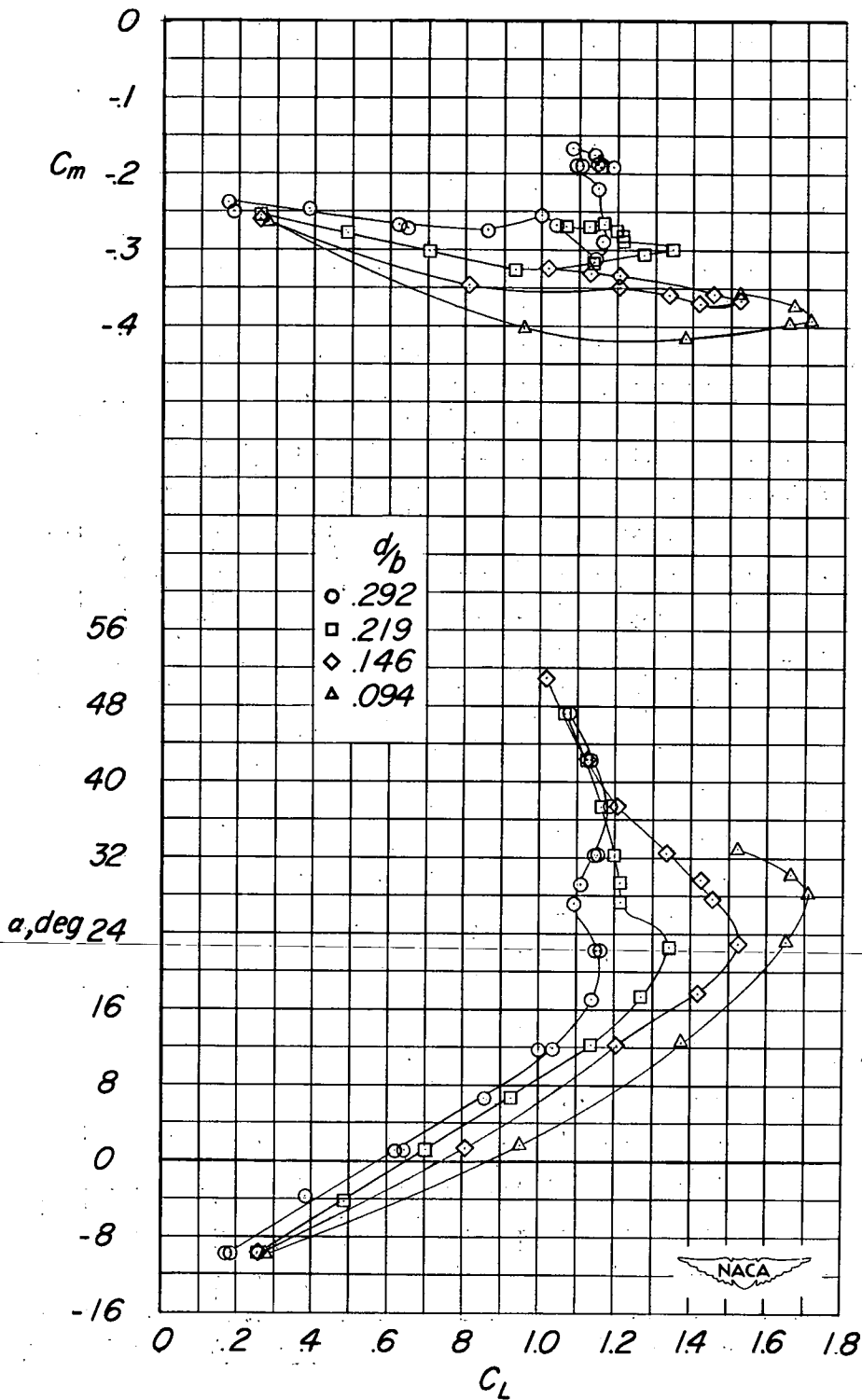

Figure 6.- Longitudinal aerodynamic characteristics of the thin 60° delta wing with fuselages of various diameters. $\delta_f = 54^\circ$.

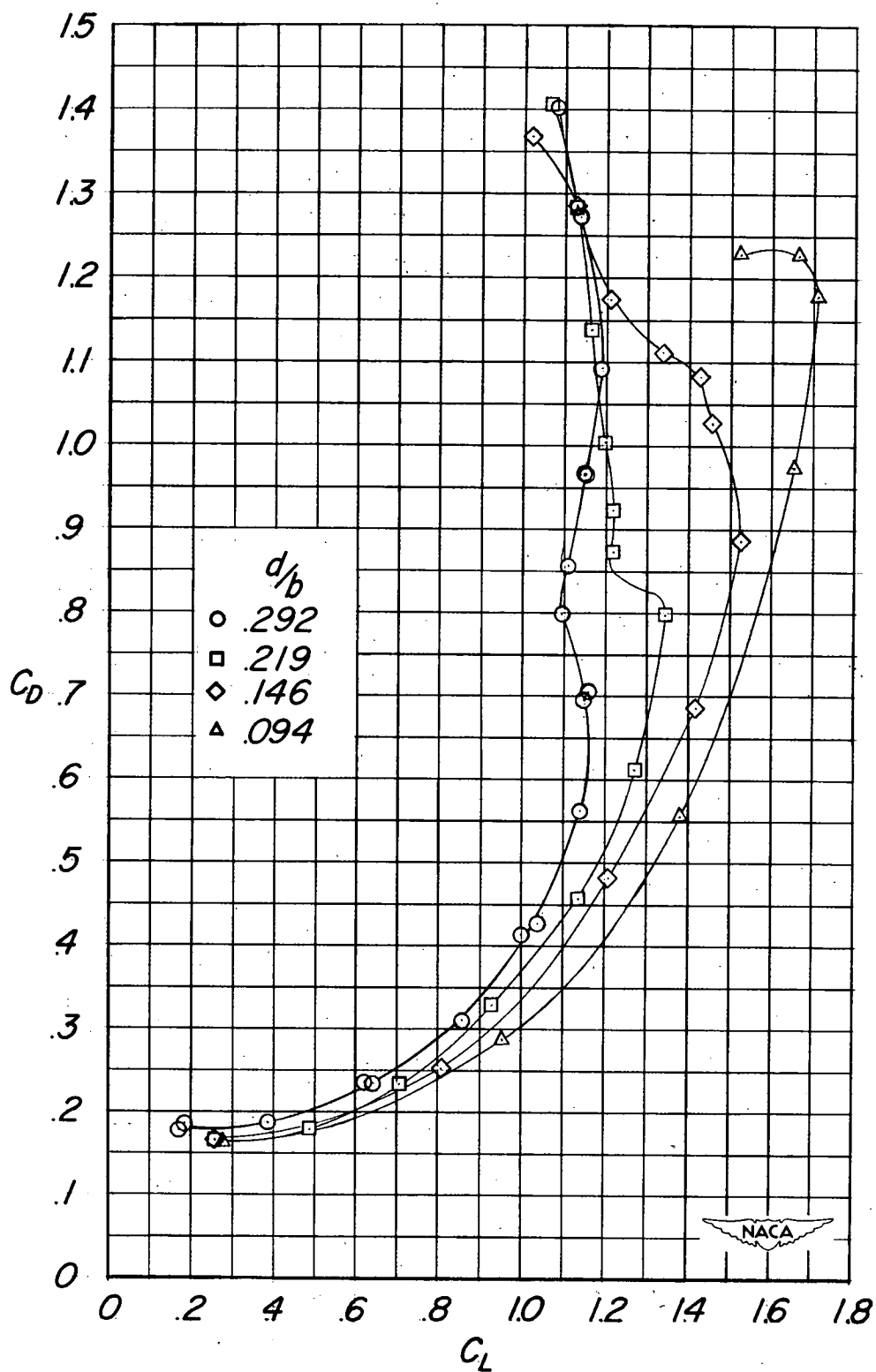

Figure 6.- Concluded.

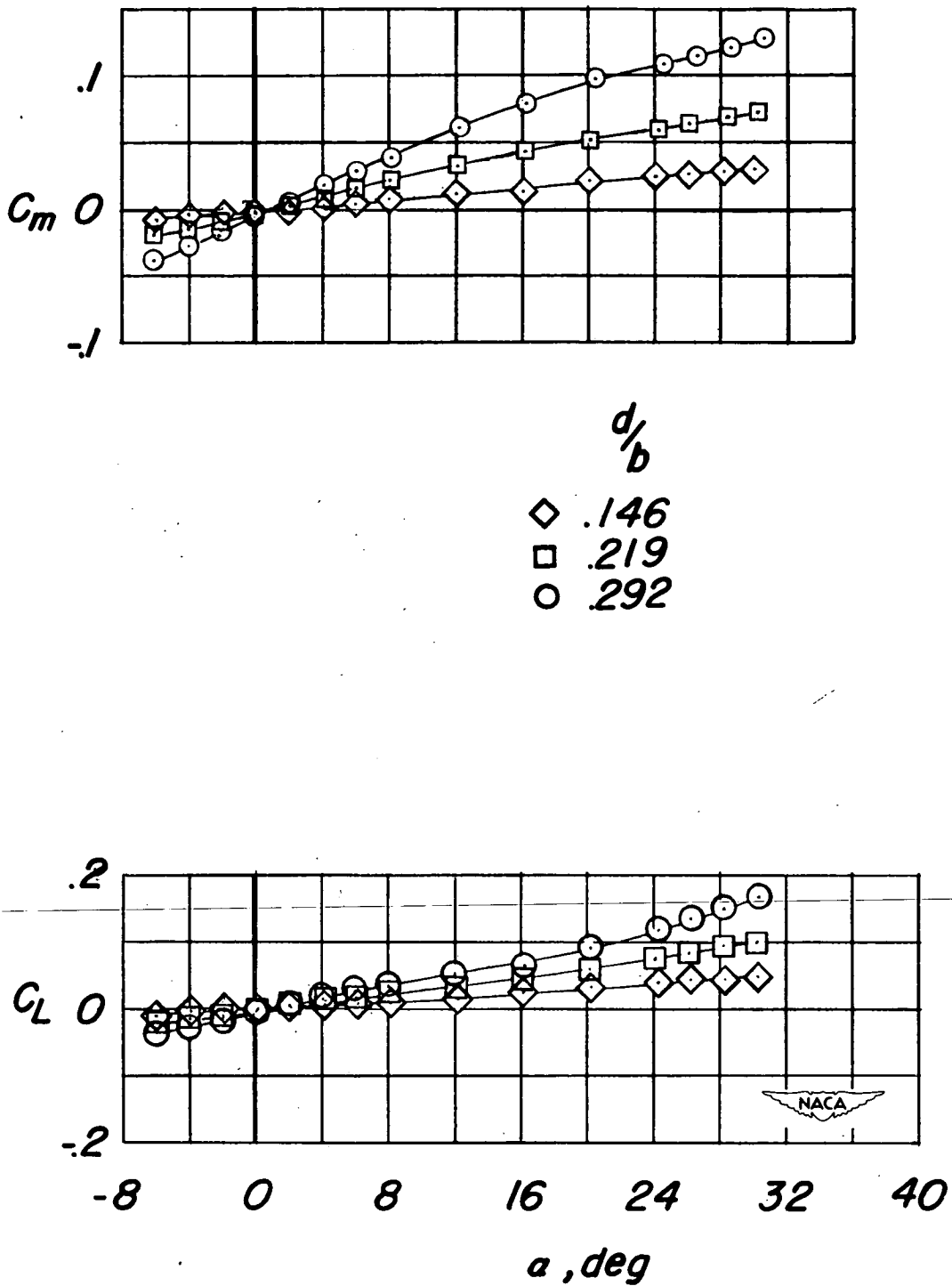

Figure 7.- Longitudinal aerodynamic characteristics of the various fuselages alone. (Coefficients are based on the delta-wing geometry.)

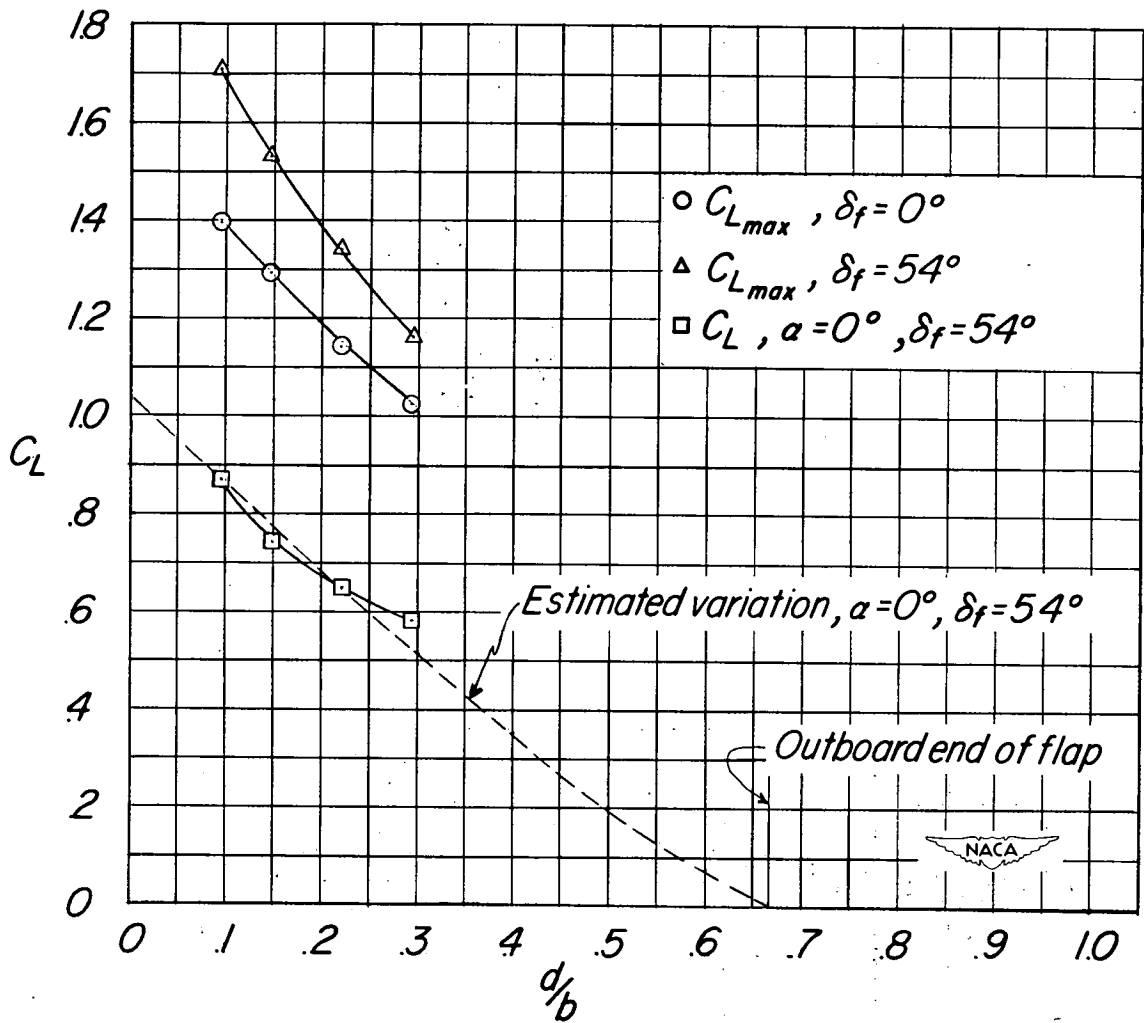

Figure 8.- Effect of fuselage-diameter-wing-span ratio on maximum lift coefficient and lift coefficient at 0° angle of attack. $\delta_f = 0^\circ$ and $\delta_f = 54^\circ$.

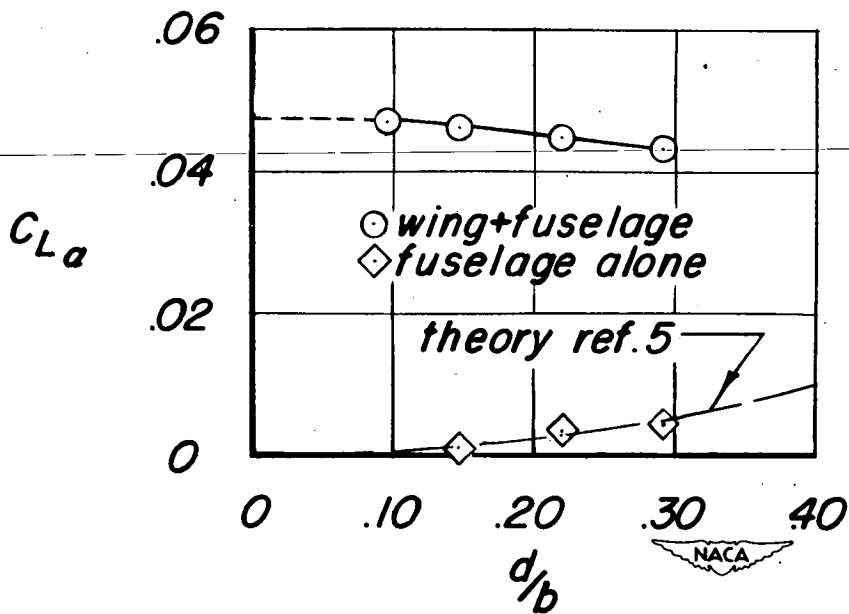
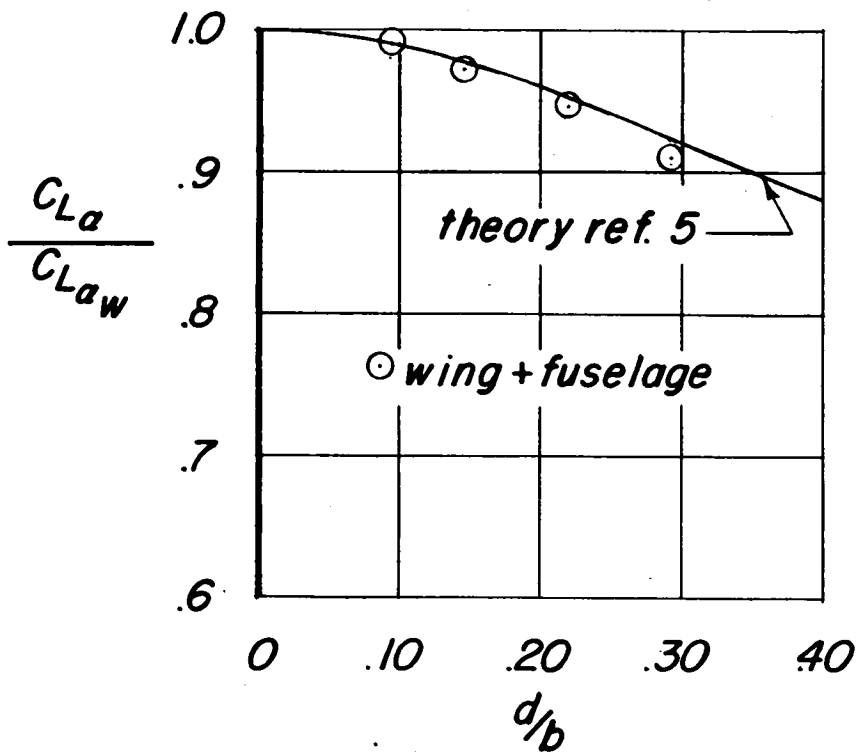

Figure 9.- Effect of fuselage-diameter-wing-span ratio on $C_{L\alpha}$ of the thin 60° delta wing. $\delta_f = 0^\circ$.

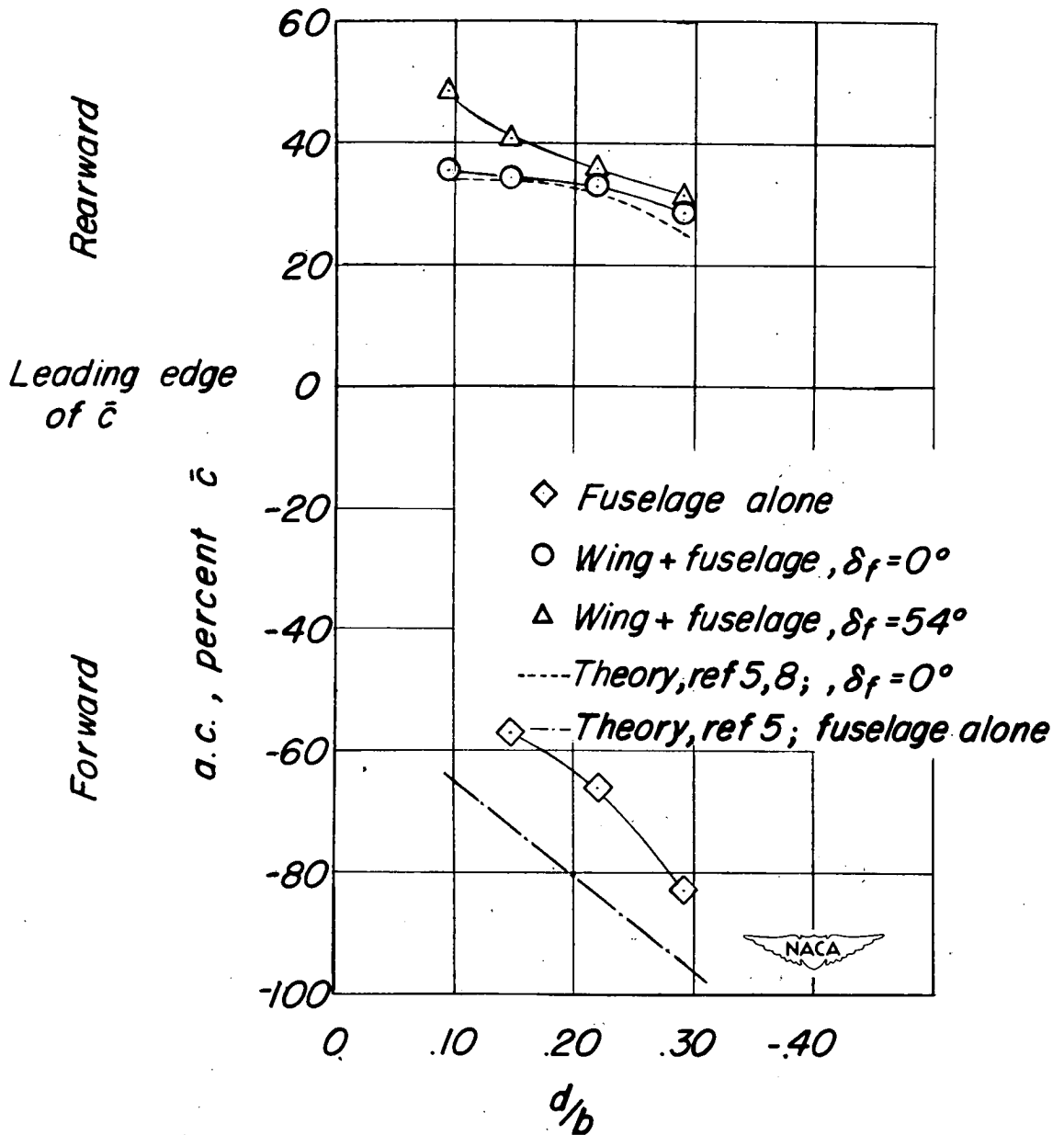

Figure 10.- Variation with fuselage-diameter-wing-span ratio of the aerodynamic-center position of the fuselage alone and wing-fuselage combination.

SECURITY INFORMATION
CONFIDENTIAL

CONFIDENTIAL