

Copy
RM L53B10-21.8

NACA RM L53B10

UNCLASSIFIED



NACA

RESEARCH MEMORANDUM

ANALYTICAL STUDIES OF THE RESPONSE TO LONGITUDINAL
CONTROL OF THREE AIRPLANE CONFIGURATIONS
IN LANDING APPROACHES

By William Bihrl, Jr. and Ralph W. Stone, Jr.

Langley Aeronautical Laboratory
Langley Field, Va.

AVAILABLE FROM NASA TO U. S. GOV'T. AGENCIES
AND U. S. GOV'T. CONTRACTORS ONLY

NOFORN

CLASSIFICATION CHANGED
UNCLASSIFIED

6-1-66
6-2-66
6-2-66
6-2-66

CLASSIFIED DOCUMENT

This material contains information affecting the National Defense of the United States within the meaning of the espionage laws, Title 18, U.S.C., Secs. 793 and 794, the transmission or revelation of which in any manner to an unauthorized person is prohibited by law.

NATIONAL ADVISORY COMMITTEE
FOR AERONAUTICS

WASHINGTON
April 9, 1953

UNCLASSIFIED

UNCLASSIFIED

NACA RM L53B10-24.B.

NATIONAL ADVISORY COMMITTEE FOR AERONAUTICS

RESEARCH MEMORANDUM

ANALYTICAL STUDIES OF THE RESPONSE TO LONGITUDINAL CONTROL OF THREE AIRPLANE CONFIGURATIONS IN LANDING APPROACHES¹

By William Bihrlé, Jr. and Ralph W. Stone, Jr.

SUMMARY

Difficulty has been reported in landing a swept-wing airplane of low aspect ratio having no horizontal tail aboard an aircraft carrier. Final small corrections to the height of the airplane in reference to the carrier deck could not be made during the short period of time available. A theoretical investigation was therefore conducted to determine the reasons for the reportedly poor airplane response to longitudinal control. Some effects of airplane configuration on the response, primarily for short time periods, were also determined.

The results of the investigation indicated that a time lag in height response may have contributed to the reported poor airplane response to longitudinal control over a short time period. For the particular airplane for which difficulty had been reported, the indicated lag in height response was mainly the result of low elevator effectiveness in changing the flight-path angle. In general, it was found that over a short time the rate of changing the flight-path angle depends mainly on the magnitude of the weight, the moment of inertia, the slopes of the curves of pitching-moment and lift coefficients as functions of elevator deflection $C_{m\delta_e}$ and $C_{L\delta_e}$, respectively, the slope of the curve of lift coefficient as a function of angle of attack $C_{L\alpha}$, and the available elevator deflection $\Delta\delta_e$. The magnitude of airplane damping and the magnitude of the lift-drag ratio, for a short period of time, do not have an appreciable effect on the time of height response.

The importance of the differences found in the response characteristics between swept-wing airplanes of low aspect ratio having no horizontal tail and conventional airplanes can be evaluated only by flight experience. Other factors such as range of vision, unusual control feel, the pilot's reaction to the relatively large nose-up attitudes of the

¹A somewhat condensed and unclassified version of this report, under the authorship of Ralph W. Stone, Jr. and William Bihrlé, Jr., entitled "Studies of Some Effects of Airplane Configuration on the Response to Longitudinal Control in Landing Approaches," was presented before the 1953 Annual Meeting of the Institute of the Aeronautical Sciences.

UNCLASSIFIED

CLASSIFICATION CHANGED

By authority of NASA. CDH/H. 6-1-41
Date
6-1-41
6-1-41

AVAILABLE FROM NASA TO U. S. GOV'T. AGENCIES AND U. S. GOV'T. CONTRACTORS ONLY

NOFORN

UNCLASSIFIED

low-aspect-ratio swept-wing airplanes, and psychological influences associated with new types of airplanes may be of equal or greater importance.

INTRODUCTION

Difficulty in landing a swept-wing airplane of low aspect ratio having no horizontal tail aboard an aircraft carrier was reported which appeared to be a problem of poor airplane response to longitudinal control primarily in the landing-approach condition prior to engine cut. Final small corrections to height of the airplane in reference to the carrier deck could not be made during the short period of time available before engine cut. For example, in an approach where a height correction had been attempted by pushing forward on the stick in order to lose some altitude, the pilot endeavored to retrim at the desired height behind the carrier deck but the airplane continued to descend. The airplane would therefore have landed short of the intended touchdown point. The pilot felt that he was not in control of the airplane as it did not respond to moving the stick rearward during the time available after the stick-forward correction.

The difficulties encountered may have been the results of aerodynamic differences between this airplane and other more conventional airplanes which are common in carrier operations. On the other hand, the difficulties may have resulted from limited vision, unusual control feel, or psychological influences associated with a new airplane, particularly a new type of airplane which has a much higher nose-up attitude in the landing approach than do conventional airplanes. A theoretical investigation was conducted in order to determine what effect the differences in aerodynamic characteristics would have on the short-time response to elevator control of this type of airplane as compared with the responses of a conventional airplane, without regard to any possible psychological influences. The results of this investigation are presented in this paper.

Longitudinal airplane motions were computed on an analog computer. The response of an airplane having reportedly good landing characteristics was compared with the response of an airplane similar in configuration to that of the airplane reportedly having poor height control, and also with the response of a third airplane having a generally similar configuration but a lower-aspect-ratio wing and different mass characteristics from those of the airplane having poor height control. The effects of the total elevator effectiveness, the change in lift due to elevator deflection, the airplane damping, and the ratio of lift to drag on the response were investigated.

SYMBOLS

The longitudinal motions presented herein were calculated about the stability axes. A diagram of the axes showing the positive directions of the forces and moment is presented in figure 1.

S	wing area, sq ft
\bar{c}	mean aerodynamic chord, ft
W	weight of airplane, lb
m	mass of airplane, W/g, slugs
k_y	radius of gyration about Y body axis, ft
ρ	air density, 0.002378 slug/cu ft
μ	airplane relative-density coefficient, $m/\rho S \bar{c}$
V	velocity, ft/sec
g	acceleration due to gravity, 32.2 ft/sec ²
L	lift, lb
D	drag, lb
M	pitching moment, ft-lb
C_L	lift coefficient, $L/\frac{1}{2}\rho V^2 S$
C_D	drag coefficient, $D/\frac{1}{2}\rho V^2 S$
C_m	pitching-moment coefficient, $M/\frac{1}{2}\rho V^2 S \bar{c}$
$C_{D_{C_{L_{max}}}}$	coefficient of drag at maximum coefficient of lift
C_{L_0}	hypothetical lift coefficient at $\alpha = 0^\circ$ based on an extrapolation from approach α , for lift-curve slope in the vicinity of approach α and with an elevator deflection which would be required to trim at approach α

C_{m_0}	hypothetical pitching-moment coefficient at $\alpha = 0^\circ$ based on an extrapolation from approach α , for pitching-moment slope in the vicinity of approach α and with an elevator deflection which would be required to trim at approach α
T	thrust, lb
Z	height, $\int_0^t V \sin \gamma \, dt$, ft
α	angle of attack, $\theta - \gamma$, deg
γ	flight-path angle, deg
θ	angle of pitch, deg
δ_e	elevator deflection, deg
ΔZ	increment of height from trimmed level-flight condition
$\Delta \alpha$	increment of angle of attack from trimmed level-flight condition
$\Delta \gamma$	increment of flight-path angle from trimmed level-flight condition
$\Delta \theta$	increment of angle of pitch from trimmed level-flight condition
ΔV	increment of velocity from trimmed level-flight condition
$\Delta \delta_e$	increment of elevator deflection from trimmed level-flight condition
$\dot{\theta}$ or q	pitching angular velocity, radians/sec
$\dot{\gamma}$	rate of change of flight-path angle with time
\dot{V}	rate of change of velocity V with time
$C_{L\delta_e} = \frac{\partial C_L}{\partial \delta_e}$	per deg
$C_{D\delta_e} = \frac{\partial C_D}{\partial \delta_e}$	per deg

$$C_{m\delta_e} = \frac{\partial C_m}{\partial \delta_e} \text{ per deg}$$

$$C_{L\alpha} = \frac{\partial C_L}{\partial \alpha} \text{ per deg}$$

$C_D(\alpha)$ coefficient of drag as a nonlinear function of α

$$C_{m\alpha} = \frac{\partial C_m}{\partial \alpha} \text{ per deg}$$

$$C_{m\dot{\alpha}} = \frac{\partial C_m}{\partial \frac{d\alpha}{dt}}$$

Dots over symbols represent derivatives with respect to time, for example, $\ddot{\gamma} = \frac{\partial^2 \gamma}{\partial t^2}$.

AIRPLANES INVESTIGATED

The configurations of the airplanes investigated are shown in figure 2. The airplanes are herein referred to as airplanes A, B, and C. Airplane A is an airplane reportedly having good landing characteristics. Airplane B, having no horizontal tail, is an airplane similar in configuration to that of the airplane reportedly having poor response to longitudinal control. Airplane C, having no horizontal tail, is an airplane having a generally similar configuration to that of airplane B but having a lower-aspect-ratio wing and different mass characteristics. Although no flight data were available regarding the landing characteristics of airplane C, this airplane was included in the investigation because, being similar to airplane B, it was believed that this airplane also might have poor response to longitudinal control. The aerodynamic, mass, and dimensional characteristics for the landing configurations of airplanes A, B, and C are given in table I.

PROCEDURE

In this investigation, the longitudinal motions of airplanes A, B, and C were calculated by an analog computer using the following equations:

$$\dot{V} = -\frac{V^2}{2\mu c} (C_{D(\alpha)} + C_{D\delta_e} \Delta\delta_e) - g \sin \gamma + \frac{T \cos \alpha}{m} \quad (1a)$$

$$\dot{\gamma} = \frac{V}{2\mu c} (C_{L\alpha} \alpha + C_{L_0} + C_{L\delta_e} \Delta\delta_e) - \frac{g \cos \gamma}{V} + \frac{T \sin \alpha}{mV} \quad (1b)$$

$$\ddot{\theta} = \frac{V^2}{2\mu k_y z} (C_{m\alpha} \alpha + C_{m_0} + C_{m\delta_e} \Delta\delta_e) + \frac{\bar{c} C_{m_q} V \dot{\theta}}{4\mu k_y z^2} \quad (1c)$$

The lift, drag, and pitching-moment coefficients were introduced as functions of angle of attack and of elevator deflection. The lift, drag, and pitching-moment coefficients as functions of angle of attack were obtained at the elevator deflection required for trimmed level flight at 185.8 ft/sec (110 knots). The variations of lift and pitching-moment coefficients with angle of attack were assumed linear and the slopes were obtained in the vicinity of the angle of attack for trimmed flight at 110 knots. The drag coefficient $C_{D(\alpha)}$, however, was introduced as a nonlinear function of angle of attack because of the large nonlinear variation of drag coefficient with angle of attack in the angle-of-attack region investigated. The variations of drag coefficient with angle of attack for airplanes A, B, and C are presented in figure 3. Airplane A had high drag at low angles of attack, primarily because of the drag due to displacement of lift flaps. The lift, drag, and pitching-moment coefficients as functions of elevator deflection were obtained at the angle of attack for trimmed level flight at 110 knots. The variations of lift, drag, and pitching-moment coefficients with elevator deflection were assumed linear and the slopes were obtained over an elevator range that extended from the elevator deflection required for trimmed flight at 110 knots to the maximum up-elevator deflection. Deflections of the elevator, and therefore

values for the $C_{L\delta_e} \Delta\delta_e$, $C_{D\delta_e} \Delta\delta_e$, and $C_{m\delta_e} \Delta\delta_e$ terms, were introduced as step functions. The thrust and C_{mq} were held constant. The aerodynamic characteristics related to the rate of change of angle of attack, $C_{L\dot{\alpha}}$, $C_{D\dot{\alpha}}$, and $C_{m\dot{\alpha}}$, were neglected. It was felt that the $\dot{\alpha}$ derivatives would not appreciably influence the motions investigated herein.

It was desired to compare the motions of the airplanes in order to determine the difference, if any, in response to longitudinal control after a motion had been initiated. In order to make the comparison, the following procedure was employed. The three airplanes were initially trimmed for steady level flight at a landing approach speed of 185.8 ft/sec (110 knots). The initial trim values are given in table II. A disturbance from steady level flight was initiated by deflecting the elevator down and holding the down deflection for 2 seconds or 1 second after which an attempt to stop the ensuing descent was made by deflecting the elevator full-up. An amount of down-elevator deflection for airplane A was chosen which when held 1 second or 2 seconds would result in a loss of altitude that might be desired for a final correction during a carrier approach. For comparison purposes, it was considered desirable to have all three airplanes follow the same path of descent to the time when the elevators were deflected full-up. An attempt to make the descent paths of airplanes B and C correspond approximately to the descent path of airplane A was made by deflecting the elevators down on airplanes B and C an amount which would approximately result in the initial rate of change of normal acceleration being the same for all three airplanes. The same initial rate of change of normal acceleration could be obtained approximately by making the initial rate of change of $\dot{\gamma}$, that is, $\ddot{\gamma}$, the same. The height is equal to $\int_0^t V \sin \gamma dt$ and it was reasoned that the amount of variation of V would be small during 1 to 2 seconds of motion and that, therefore, the descent path would be determined entirely by the factor $\sin \gamma$. It was felt, therefore, that if the initial $\ddot{\gamma}$ values were made the same for all three airplanes the descent paths would also be approximately the same over a short time interval. The down-elevator deflections required for airplanes B and C were determined on the basis that the initial value of $\ddot{\gamma}$ was proportional to $\frac{VC_{L\alpha}}{2\mu\bar{c}} \frac{v^2 C_{m\delta_e}}{2\mu k_y^2} \Delta\delta_e$. The increment of force affecting the normal acceleration due to elevator deflection was neglected. The analysis used for obtaining this parameter is given in the appendix. The amount the elevator was deflected down from the initial trim deflection for 1 second or 2 seconds on airplanes A, B, and C is given in table III. As

previously mentioned, the elevator on each airplane was then deflected from the specific down setting to the full-up position. The amount of elevator deflection thus made on airplanes A, B, and C is given in table III. The use of full-up elevator would give the maximum acceleration in pitch possible for a given airplane configuration. It was realized that use of full-up elevator and the introduction of elevator deflection as step functions do not simulate the actual control deflections that would be used by a pilot, but it was felt that the use of this procedure would reveal any differences in response due to inherent stability and control characteristics that might exist between airplanes A, B, and C. This procedure was employed therefore to get the maximum response that would be theoretically possible for a given airplane configuration. The elevator deflection was reduced from full-up to a deflection that would trim the airplane at the angle of attack of maximum lift and also was reduced in time to prevent the airplane from exceeding by more than approximately 3° the angle of attack of maximum lift.

The motion in response to the prescribed elevator deflections was recorded in terms of velocity, angle of pitch, angle of attack, flight-path angle, and height with respect to time. These values are presented herein as increments from the initial trim values presented in table II. The motions are presented until the lost height is regained. The effects of the total elevator effectiveness, the change in lift due to elevator deflection, the airplane damping, and the ratio of lift to drag on the response of the airplane were determined. (The phrase "total elevator effectiveness" refers to the effectiveness of the available elevator deflection in causing an initial rate of change of flight-path angle.) In order to determine the effects of these factors on the response, the factors involved were changed and the resulting motion was compared with the motion obtained for the original condition.

The effect of total elevator effectiveness on response was determined by increasing the elevator deflections on airplanes B and C. The values of total elevator effectiveness on airplanes B and C were increased amounts which resulted in the total elevator effectiveness of these airplanes corresponding to the total elevator effectiveness of airplane A. This was attempted by increasing the up-elevator deflections of airplanes B and C an amount, determined by the method described previously, such that all three airplanes would have approximately the same initial increment in $\dot{\gamma}$ at pull-up. The amounts the elevators were deflected up from the down position are given in table III.

The effects of the change in lift due to elevator deflection on the responses of airplanes B and C were determined by making $CL_{\delta_e} = 0$ and comparing the resulting motions with the motions obtained for the original condition. The effect of increasing the total elevator

effectiveness by increasing the elevator deflection and at the same time eliminating the change in lift due to elevator deflection on the response was also determined for airplanes B and C.

The effect of the airplane-damping term on response was determined by making $C_{m_q} = -3.5$ and -12.0 on airplane B and comparing the resulting motion with the motion obtained for the original condition ($C_{m_q} = -1.5$).

The effect of L/D on the response of airplane B was determined by changing the polar curve of airplane B and the resulting motion was compared with that obtained for the original condition. The ratio of lift coefficient to drag coefficient of airplane B was made equal to that of airplane A over approximately the range from trim lift to maximum lift by changing the drag curve of airplane B. The variation of drag coefficient with angle of attack used for airplane B is given in figure 3.

RESULTS

Comparison of Airplanes A, B, and C

All three airplanes (fig. 4) respond to the up-elevator deflection in that the descent is stopped and the lost height is regained. It takes approximately twice as much time, however, for airplane B to stop its descent or to regain its lost height after up-elevator movement as it does for airplane A. It is therefore indicated that a pilot might become aware of the difference in response between airplanes B and A when attempting small height corrections during a short period of time. During the added time required to stop its descent, airplane B would have traveled approximately 186 feet, because its velocity was 185.8 ft/sec (110 knots). Some lag in the response of airplane C, when compared with airplane A, was also present but its response was considerably better than that of airplane B. Figure 4 shows that airplane A, in response to the up-elevator deflection, was able to accelerate more quickly in angle of pitch, angle of attack, and flight-path angle than airplanes B and C which accounts for airplane A responding more quickly in height than did airplanes B and C. The influence that the configurations of airplanes B and C had on the lag in height response are given in the sections that follow.

Effect of Changes on Airplane B

The effect of increasing the total elevator effectiveness on the response of airplane B is shown in figure 5. As previously mentioned,

the phrase "total elevator effectiveness" refers herein to the effectiveness of the available elevator deflection in causing an initial rate of change of flight-path angle. Increasing the total elevator effectiveness to that of airplane A (with the difference in the change in lift due to elevator deflection neglected) by increasing the up-elevator deflection greatly improved the response of airplane B. Eliminating the change in lift due to elevator deflection (fig. 5) gave some improvement in response. Increasing the up-elevator deflection and making $C_{L\delta_e} = 0$ gave the quickest response.

For the given down- and up-elevator deflection (forcing function), increasing C_{m_q} (fig. 6) had essentially no effect on the time it takes the airplane to stop its descent. The magnitudes of angle of pitch, angle of attack, flight-path angle, and height were decreased, however, as C_{m_q} was increased.

When L/D (fig. 7) was increased to that of airplane A, the lag in response was improved only slightly. The importance of this factor on the response of an airplane over a more extended time period will be examined later herein.

Effect of Changes on Airplane C

Since increasing the total elevator effectiveness was shown to be the important factor in decreasing the lag in height response of airplane B, this factor was also changed on airplane C (fig. 8). Increasing the total elevator effectiveness to that of airplane A (with the difference in the change in lift due to elevator deflection neglected) by increasing the up-elevator deflection gave some improvement in the response of airplane C. The response was improved to a much greater extent when the change in lift due to elevator deflection was eliminated. Whereas increasing the total elevator effectiveness by increasing the up-elevator deflection affected the response of airplane B more than airplane C, eliminating the change in lift due to elevator deflection affected the response of airplane C more than that of airplane B. An explanation of these effects is to be given later herein. The quickest response was obtained, as for airplane B, when the up-elevator deflection was increased and $C_{L\delta_e}$ was made equal to zero.

For ease of comparison, the motions obtained for airplane A are compared in figure 9 with the motions obtained for airplanes B and C when the total elevator effectiveness had been increased by increasing the up-elevator deflection and making $C_{L\delta_e} = 0$. It can be seen that the responses of airplanes B and C now compare very favorably with the

response of airplane A. The improvement in response of airplanes B and C, from that shown on figure 4 for the original condition, was obtained by increasing the total elevator effectiveness and by making $C_{L\delta_e} = 0$.

DISCUSSION

Examining some of the parameters which are involved in the longitudinal motion may give an understanding of the results that were obtained. The parameters for airplanes B and C are given relative to those for airplane A in table IV. These parameters include the aerodynamic, control, and mass characteristics and are indicative, comparatively, of the motion to be expected at the time the control is deflected.

The parameter $\frac{V^2 C_{m\delta_e}}{2\mu k_y^2}$ indicates the effectiveness of the elevator with respect to its ability to produce a high rate of change in angle of pitch. The elevators of airplanes B and C were less effective than that

of airplane A. The parameter $\frac{VC_{L\alpha}}{2\mu\bar{c}}$ indicates the ability of the configuration, when pitched, to change the lift and, therefore, the normal acceleration. Airplane B was less effective than, and airplane C was about as effective as, airplane A in changing the lift due to angle

of attack. The parameter $\frac{VC_{L\alpha}}{2\mu\bar{c}} \frac{V^2 C_{m\delta_e}}{2\mu k_y^2}$ obtained by combining the two parameters is indicative (see appendix) of the elevator effectiveness on the rate of change of flight-path angle (with the $C_{L\delta_e}$ term neglected, however). Based on this parameter, airplanes B and C were approximately 2/5 and 3/4, respectively, as effective as airplane A.

The amount of elevator deflection available from the down deflection to the full-up position on airplanes B and C is given in table III relative to the amount of elevator deflection available on airplane A. Airplanes B and C had a smaller amount of up-elevator deflection available than did airplane A. Airplane B had the least of all three air-

planes. The total elevator effectiveness $\frac{VC_{L\alpha}}{2\mu\bar{c}} \frac{V^2 C_{m\delta_e}}{2\mu k_y^2} \Delta\delta_e$ available

for airplanes B and C was about 1/4 and 2/3, respectively, of the total elevator effectiveness available for airplane A (table III). This would indicate why airplane B had the greatest lag in height response (fig. 4). For airplanes B and C to have the total elevator effectiveness of airplane A, it was necessary to increase the amount of up-elevator

deflection 4 times and $1\frac{1}{2}$ times the original up-elevator deflection on airplanes B and C, respectively (table III). The elevator deflection used for airplane B was approximately -74° and it was realized that the deflection was excessively large and beyond the linear range of $C_{m\delta_e}$. The change required on airplane B, however, is illustrative of the differences in the airplanes. Since airplane B lacked so much more total elevator effectiveness than did airplane C, it is understandable why the greatest improvement in response was obtained on airplane B when the total elevator effectiveness was increased by increasing the up-elevator deflection.

The parameter $\frac{VC_{L\delta_e}}{2\mu\bar{c}}$ (table IV) indicates the change in lift and, therefore, normal acceleration due to elevator deflection. When the elevator is initially deflected this change in lift opposes the change in lift due to a desired change in angle of attack. As seen from the motions presented herein, the parameter $\frac{VC_{L\delta_e}}{2\mu\bar{c}}$ introduces a lag in changing the flight-path angle and, therefore, in height response. The change in lift due to elevator deflection was approximately 2 and 3 times greater for airplanes B and C, respectively, than for airplane A (table IV). Considering the up-elevator deflections available, it can be seen (table III) that the parameter $\frac{VC_{L\delta_e} \Delta\delta_e}{2\mu\bar{c}}$ for airplane B was about the same as for airplane A, whereas the parameter for airplane C was approximately $2\frac{1}{3}$ times that of airplane A. Since this parameter, for airplane C, was more than twice as large as that for airplane B, a greater improvement in height response was obtained on airplane C than on airplane B when the $C_{L\delta_e}$ term was made zero.

The time it takes an airplane of a specific configuration to respond in height, for a given elevator deflection, depends on the rate at which it can change the flight-path angle. For a short-period motion, the rate of change of the flight-path angle depends mainly on the magnitude of weight, moment of inertia, $C_{m\delta_e}$, $C_{L\alpha}$, $C_{L\delta_e}$, and $\Delta\delta_e$. An increase in weight, moment of inertia, or $C_{L\delta_e}$ or a decrease in $C_{m\delta_e}$, $C_{L\alpha}$, or $\Delta\delta_e$ will tend to decrease the ability of the airplane to respond quickly in height. Most airplanes having no horizontal tail will have low values of $C_{m\delta_e}$ and high values of $C_{L\delta_e}$ and therefore

should be expected to have a lag in height response when compared with an airplane having the same weight, moment of inertia, $C_{L_{\alpha}}$, and $\Delta\delta_e$ but having a horizontal tail.

In order to determine the effects of some factors on the response over a long time period, the motions for all three airplanes presented and compared in figures 4 and 9 for the 2-second cases are continued for a longer time period in figures 10 and 11, respectively. As was mentioned previously, all three airplanes respond to the up-elevator deflection in that the descent is stopped and the lost height is regained. Figure 10 shows that the height continues to increase over a considerable time after the lost height is regained. If an airplane is flying at an attitude such that an increment of lift will be obtained when pitched up by the up-elevator deflection the airplane will initially respond by gaining height due to the resulting excess velocity present. Figures 10 and 11 show that the effect of drag on the velocity is a long-period effect. The additional drag obtained when the airplanes were pitched up absorbs velocity over approximately 10 seconds during which time the airplanes are gaining height. Mention might be made that the magnitude of height change (change of potential energy) to be obtained, depends on the amount of change of the kinetic energy. The application, therefore, of elevator deflections as step functions or ramp functions will give the same magnitude of height change. The magnitude of height to be eventually attained and the time at which it will be attained, for a given elevator deflection, depends on the amount of lift and drag incurred. As shown in figure 10, airplanes B and C did not gain as much height as airplane A because airplanes B and C had either greater values of $C_{L_{trim}}/C_{L_{max}}$ or smaller values of $C_{D_{trim}}/C_{D_{C_{L_{max}}}}$ than did airplane A. A comparison of figures 10 and 11 shows that when airplanes B and C had $C_{L_{\delta_e}} = 0$, indirectly a greater increment of lift was obtained by this procedure, the airplanes responded in attaining a greater change in height magnitude. It can be said that values of L/D obtained during the longitudinal motion affect the response in time and magnitude of the maximum height to be attained over a long time period. All airplanes eventually assumed a glide angle and descended because of the increased drag at the new angles of attack, but if the thrust, which had been maintained constant, had been increased accordingly the airplanes could have been retrimmed for steady level flight at the maximum heights obtained.

CONCLUDING REMARKS

The results of the investigation presented herein indicated that poor airplane response to longitudinal control over a short time period,

as was reported for a specific configuration, may have been the result of a time lag in height response. The lag in height response was mainly the result of a low elevator effectiveness in changing the flight-path angle. In general, it was found that, over a short time, the rate of change of the flight-path angle depends mainly on the magnitude of the weight, the moment of inertia, the slopes of the curves of pitching-moment and lift coefficients as functions of elevator deflection $C_{m_{\delta_e}}$ and $C_{L_{\delta_e}}$, respectively, the slope of the curve of lift coefficient as a function of angle of attack $C_{L_{\alpha}}$, and the available elevator deflection $\Delta\delta_e$.

An increase in weight, moment of inertia, or $C_{L_{\delta_e}}$, or a decrease in $C_{m_{\delta_e}}$, $C_{L_{\alpha}}$, or $\Delta\delta_e$ will tend to decrease the ability of the airplane to respond quickly in height. The magnitude of airplane damping and the magnitude of the lift-drag ratio, for a short period of time, did not have an appreciable effect on the time of height response.

The importance of the differences found in the response characteristics between swept-wing airplanes of low aspect ratio having no horizontal tail and conventional airplanes can only be evaluated by flight experience. Other factors such as range of vision, unusual control feel, the pilot's reaction to the relatively large nose-up attitudes of the swept-wing airplanes of low aspect ratio and psychological influences associated with new types of airplanes may be of equal or greater importance.

Langley Aeronautical Laboratory,
National Advisory Committee for Aeronautics,
Langley Field, Va.

APPENDIX

A CONSIDERATION OF FACTORS PERTINENT TO LONGITUDINAL
RESPONSE OF AIRPLANES IN SHORT TIME PERIODS

The calculations performed in this paper were, as previously noted, based on the three longitudinal equations of motion and the calculations are accurate to the extent of the completeness and accuracy of the aerodynamic characteristics used. Consideration of airplane longitudinal stability for short-period oscillations has shown that the pertinent factors regarding the short-period modes may be obtained from consideration of only two degrees of freedom assuming the velocity to be constant. It is possible, therefore, that factors pertinent to short-time responses to longitudinal control movement also may be obtained from consideration of only two degrees of freedom. These degrees of freedom are expressed in the equations of the normal and pitching accelerations previously given in the text as equations (1b) and (1c), respectively.

If the initial trimmed conditions are subtracted from these equations, the following expressions result:

$$\dot{\gamma} = \frac{V}{2\mu c} (C_{L\alpha} \Delta\alpha + C_{L\delta_e} \Delta\delta_e) - \frac{g[\cos(\gamma + \Delta\gamma) - \cos \gamma]}{V} + \frac{T[\sin(\alpha + \Delta\alpha) - \sin \alpha]}{mV} \quad (A1)$$

$$\ddot{\theta} = \frac{C_{m\dot{q}} \bar{c} V \dot{\theta}}{4\mu k_y^2} + \frac{V^2}{2\mu k_y^2} (C_{m\alpha} \Delta\alpha + C_{m\delta_e} \Delta\delta_e) \quad (A2)$$

The gravitational and thrust force terms in equation (A1) can be shown to be of a lower order than are the aerodynamic-lift terms and, therefore, are of secondary importance to the motion. The remaining terms in equation (A1) are the lift due to a change in angle of attack $C_{L\alpha} \Delta\alpha$, the primary force for changing the flight path, and the lift due to

the control deflection $C_{L\delta_e} \Delta\delta_e$, which is an inherent force which opposes the desired change in normal acceleration and flight path. If factors of secondary importance are neglected, equation (A1) may be written as

$$\dot{\gamma} = \frac{V}{2\mu\bar{c}} (C_{L\alpha} \Delta\alpha + C_{L\delta_e} \Delta\delta_e) \quad (A3)$$

from which

$$\Delta\alpha = \frac{2\mu\bar{c}}{VC_{L\alpha}} \dot{\gamma} - \frac{C_{L\delta_e}}{C_{L\alpha}} \Delta\delta_e$$

and

$$\dot{\alpha} = \frac{2\mu\bar{c}}{VC_{L\alpha}} \ddot{\gamma}$$

$$\ddot{\alpha} = \frac{2\mu\bar{c}}{VC_{L\alpha}} \dddot{\gamma}$$

Since $\theta = \alpha + \gamma$, equation (A2), with proper substitutions, may be written as

$$\dddot{\gamma} + \left(\frac{VC_{L\alpha}}{2\mu\bar{c}} - \frac{VC_{m\alpha}\bar{c}}{4\mu k_y^2} \right) \ddot{\gamma} + \left(-\frac{V^2 C_{L\alpha} C_{m\alpha}}{8\mu^2 k_y^2} - \frac{V^2 C_{m\alpha}}{2\mu k_y^2} \right) \dot{\gamma} = -\frac{VC_{L\delta_e}}{2\mu\bar{c}} \frac{V^2 C_{m\alpha}}{2\mu k_y^2} \Delta\delta_e +$$

$$\frac{VC_{L\alpha}}{2\mu\bar{c}} \frac{V^2 C_{m\delta_e}}{2\mu k_y^2} \Delta\delta_e \quad (A4)$$

A solution of this equation for the flight-path angle γ gives the following results:

$$\gamma = \frac{VC_{L\delta_e}}{2\mu\bar{c}} \left(\frac{a}{b} + \frac{\lambda_2^2 e^{\lambda_1 t} - \lambda_1^2 e^{\lambda_2 t}}{b\sqrt{a^2 - 4b}} \right) \Delta\delta_e + \frac{VC_{L\delta_e}}{2\mu\bar{c}} \frac{v^2 C_{m\alpha}}{2\mu k_y^2} \left[\frac{\lambda_2^2 e^{\lambda_1 t} - \lambda_1^2 e^{\lambda_2 t}}{b^2\sqrt{a^2 - 4b}} - \left(\frac{t}{b} - \frac{a}{b^2} \right) \Delta\delta_e - \frac{VC_{L\alpha}}{2\mu\bar{c}} \frac{v^2 C_{m\delta_e}}{2\mu k_y^2} \left[\frac{\lambda_2^2 e^{\lambda_1 t} - \lambda_1^2 e^{\lambda_2 t}}{b^2\sqrt{a^2 - 4b}} - \left(\frac{t}{b} - \frac{a}{b^2} \right) \Delta\delta_e \right] \right] \Delta\delta_e \quad (A5)$$

where

$$a = \frac{VC_{L\alpha}}{2\mu\bar{c}} - \frac{VC_{m\bar{c}}}{4\mu k_y^2}$$

$$b = - \frac{v^2 C_{L\alpha} C_{m\bar{c}}}{8\mu^2 k_y^2} - \frac{v^2 C_{m\alpha}}{2\mu k_y^2}$$

$$\lambda_1 = - \frac{a}{2} - \frac{\sqrt{a^2 - 4b}}{2}$$

and

$$\lambda_2 = - \frac{a}{2} + \frac{\sqrt{a^2 - 4b}}{2}$$

The change in height $\Delta Z = \int V \sin \gamma dt$ appears to be the important factor concerning the problem of short-time response, the value of γ given in equation (A5) is of prime importance if the velocity is assumed to be approximately constant. Thus the factors influencing γ in equation (A5) are those factors pertinent to the short-time responses to longitudinal control movement.

If the lift due to the control deflection $C_{L\delta_e}$ was zero, then γ would be directly proportional to the factor

$$\frac{VC_{L\alpha}}{2\mu\bar{c}} \frac{V^2 C_{m\delta_e}}{2\mu k_y^2} \Delta\delta_e$$

In this paper this factor was made the same for all airplanes, in order to make the initial flight paths approximately the same in the push-over, by using appropriate amounts of elevator deflection. Similarly, when the elevator was moved up to check the descent, this factor, based on the initial velocity, also was used although the velocities had changed somewhat and the values of γ and $\dot{\gamma}$ at the time the elevator was moved up were only approximately similar for all airplanes. This factor has been termed the total elevator effectiveness and, for the up-elevator cases when this factor was made the same, based on the initial velocity, the airplanes were said to have the same total elevator effectiveness.

The contributions to γ due to the terms containing the lift due to elevator deflection $C_{L\delta_e}$ are compared with the contributions of the terms containing the lift due to angle of attack $C_{L\alpha}$ in table V. The contributions to γ of the $C_{L\delta_e}$ terms for airplane A are about 7 percent of the contribution of $C_{L\alpha}$ terms, whereas for airplanes B and C the contribution is about 1/4 to 1/3 of the contribution of $C_{L\alpha}$ terms.

It is apparent that the other aerodynamic characteristics $C_{m\alpha}$ and $C_{m\dot{q}}$ will influence the motion and are of increasing importance as the time in the motion increases. Of major importance to this contribution to the motion is the term

$$b = - \frac{V^2 C_{L\alpha} C_{mq}}{8\mu^2 k_y^2} - \frac{V^2 C_{m\alpha}}{2\mu k_y^2}$$

In spite of the widely varied aerodynamic characteristics of airplanes A, B, and C, the values of b are similar for these airplanes.

A solution of equation (A4) for the derivatives of γ gives the following results:

$$\dot{\gamma} = - \left(\frac{VC_{L\alpha}}{2\mu\bar{c}} \frac{VC_{L\delta_e}}{2\mu\bar{c}} \frac{VC_{mq}\bar{c}}{4\mu k_y^2} + \frac{VC_{L\alpha}}{2\mu\bar{c}} \frac{V^2 C_{m\delta_e}}{2\mu k_y^2} \right) \frac{\lambda_2 e^{\lambda_1 t} - \lambda_1 e^{\lambda_2 t}}{b(\lambda_2 - \lambda_1)} \Delta\delta_e +$$

$$\left(\frac{VC_{L\alpha}}{2\mu\bar{c}} \frac{V^2 C_{m\delta_e}}{2\mu k_y^2} - \frac{VC_{L\delta_e}}{2\mu\bar{c}} \frac{V^2 C_{m\alpha}}{2\mu k_y^2} \right) \frac{\Delta\delta_e}{b} \quad (A6)$$

$$\ddot{\gamma} = - \left(\frac{VC_{L\alpha}}{2\mu\bar{c}} \frac{VC_{L\delta_e}}{2\mu\bar{c}} \frac{VC_{mq}\bar{c}}{4\mu k_y^2} + \frac{VC_{L\alpha}}{2\mu\bar{c}} \frac{V^2 C_{m\delta_e}}{2\mu k_y^2} \right) \frac{e^{\lambda_1 t} - e^{\lambda_2 t}}{\lambda_2 - \lambda_1} \Delta\delta_e \quad (A7)$$

$$\ddot{\gamma} = - \left(\frac{VC_{L\alpha}}{2\mu\bar{c}} \frac{VC_{L\delta_e}}{2\mu\bar{c}} \frac{VC_{mq}\bar{c}}{4\mu k_y^2} + \frac{VC_{L\alpha}}{2\mu\bar{c}} \frac{V^2 C_{m\delta_e}}{2\mu k_y^2} \right) \frac{\lambda_1 e^{\lambda_1 t} - \lambda_2 e^{\lambda_2 t}}{\lambda_2 - \lambda_1} \Delta\delta_e \quad (A8)$$

Examination of these equations indicates that at zero time for a step input of elevator deflection, making the factor

$$\frac{VC_{L\alpha}}{2\mu\bar{c}} \frac{V^2 C_{m\delta_e}}{2\mu k_y^2} \Delta\delta_e$$

the same for all three airplanes makes $\ddot{\gamma}$ (eq. (A8)) at zero time, approximately the same in that the other term is of lower order and therefore of only secondary importance. The rate of change of the normal acceleration, which is proportional to $\dot{\gamma}$ (eq. (A7)), also will be approximately the same for all airplanes at the beginning of the motion.

TABLE I.- AERODYNAMIC, MASS, AND DIMENSIONAL CHARACTERISTICS

[Aerodynamic characteristics are referred to stability axes; mass and aerodynamic characteristics given for landing configuration]

Characteristic	Airplane A	Airplane B	Airplane C
Wing area, sq ft	400.0	535.3	557
Mean aerodynamic chord, ft	8.28	13.69	18.25
Weight, lb	19,642	22,862	14,517
Center of gravity, percent \bar{c}	25	14	24
Moment of inertia about Y body axis, slug-ft ²	40,658	43,750	31,707
Radius of gyration about Y body axis, ft	8.17	7.85	8.38
Airplane relative-density coefficient, μ	77.4	40.7	18.6
Mass parameter $\frac{1}{2\mu k_y^2}$, ft ⁻²	97×10^{-6}	199×10^{-6}	382×10^{-6}
Mass parameter $\frac{1}{2\mu c}$, ft ⁻¹	78×10^{-5}	90×10^{-5}	147×10^{-5}
C_{m_q} per radian	-12.0	-1.5	-0.5
$C_{m_{\delta_e}}$ per degree	-0.0172	-0.0050	-0.0031
$C_{L_{\delta_e}}$ per degree	0.00600	0.01025	0.00900
$C_{D_{\delta_e}}$ per degree	0.00056	0.00090	0.00095
C_{m_α} per degree	-0.01034	-0.00675	-0.00400
C_{L_α} per degree	0.0842	0.0525	0.0476
C_{m_o}	0.0172	0.1475	0.063
C_{L_o}	0.814	-0.187	-0.158
$C_{D(\alpha)}$	(a)	(a)	(a)
$C_{L_{trim}}/C_{L_{max}}$ (trim at 110 knots)	0.630	0.793	0.648
$C_{D_{trim}}/C_{D_{C_{L_{max}}}}$ (trim at 110 knots)	0.577	0.609	0.353
$\delta_{e_{max}}$, deg	-18	-30	-20

^a Shown in figure 3.

TABLE II.- INITIAL TRIM VALUES FOR STEADY
LEVEL FLIGHT AT 185.8 FT/SEC (110 KNOTS)

Airplane	α , deg	γ , deg	θ , deg	T, lb	δ_e , deg
A	4.40	0	4.40	2,642	5.0 (1.5° up stabilizer)
B	21.85	0	21.85	4,770	-20.0
C	15.97	0	15.97	2,781	-1.5 (30° up trimmer)



TABLE III.- ELEVATOR DEFLECTIONS USED AND COMPARISON OF RESULTING PARAMETERS

AFFECTING LONGITUDINAL MOTION

[Parameters for airplanes B and C given relative to those for airplane A]

Airplane	Push-down $\Delta\delta_e$, deg (from trim elevator deflection)	Pull-up $\Delta\delta_e$, deg (from push-down elevator deflection)	$\frac{\Delta\delta_e}{(\Delta\delta_e)_A}$ (for pull-up)	$\frac{v^2 c_{m\delta_e} \Delta\delta_e}{2\mu k_y^2} \frac{VC_{L\alpha}}{2\mu\bar{c}}$ $\left(\frac{v^2 c_{m\delta_e} \Delta\delta_e}{2\mu k_y^2} \frac{VC_{L\alpha}}{2\mu\bar{c}} \right)_A$ (a)	$\frac{VC_{L\delta_e} \Delta\delta_e}{2\mu\bar{c}}$ $\left(\frac{VC_{L\delta_e} \Delta\delta_e}{2\mu\bar{c}} \right)_A$ (b)
Original elevator deflection					
A	1.86	-24.86	----	----	----
B	^c 4.33	-14.33	0.58	0.25	1.14
C	^c 2.45	-20.95	.84	.64	2.37
Increased up-elevator deflection					
B	^c 4.33	^c -57.81	2.33	1.00	----
C	^c 2.45	^c -32.71	1.32	1.00	----

^aParameter indicates total available elevator effectiveness in causing a rate of change of flight-path angle (neglecting change in lift due to elevator deflection).

^bParameter indicates change in lift due to elevator deflection.

^cThese $\Delta\delta_e$ values resulted in the initial increment of $\dot{\gamma}$ being approximately the same as for airplane A (neglecting change in lift due to elevator deflection).



TABLE IV.- COMPARISON OF PARAMETERS AFFECTING LONGITUDINAL MOTION

[Parameters for airplanes B and C given relative to those for airplane A]

Airplanes	$\frac{1}{2\mu k_y^2}$	$C_{m\delta_e}$	$\frac{v^2 C_{m\delta_e}}{2\mu k_y^2}$	$\frac{1}{2\mu \bar{c}}$	$C_{L\delta_e}$	$\frac{VC_{L\delta_e}}{2\mu \bar{c}}$	$C_{L\alpha}$	$\frac{VC_{L\alpha}}{2\mu \bar{c}}$	$\frac{v^2 C_{m\delta_e}}{2\mu k_y^2} \frac{VC_{L\alpha}}{2\mu \bar{c}}$
	$\left(\frac{1}{2\mu k_y^2}\right)_A$	$(C_{m\delta_e})_A$	$\left(\frac{v^2 C_{m\delta_e}}{2\mu k_y^2}\right)_A$	$\left(\frac{1}{2\mu \bar{c}}\right)_A$	$(C_{L\delta_e})_A$	$\left(\frac{VC_{L\delta_e}}{2\mu \bar{c}}\right)_A$	$(C_{L\alpha})_A$	$\left(\frac{VC_{L\alpha}}{2\mu \bar{c}}\right)_A$	$\left(\frac{v^2 C_{m\delta_e}}{2\mu k_y^2} \frac{VC_{L\alpha}}{2\mu \bar{c}}\right)_A$
			(a)			(b)			(c)
B	2.06	0.29	0.60	1.15	1.71	1.97	0.62	0.71	0.43
C	3.94	.18	.71	1.88	1.50	2.82	.57	1.07	.76

^aParameter indicates elevator effectiveness in causing a rate of change of pitch angle.

^bParameter indicates change in lift due to elevator deflection.

^cParameter indicates elevator effectiveness in causing a rate of change of flight-path angle (neglecting change in lift due to elevator deflection).



TABLE V.- THE CONTRIBUTIONS TO γ OF TERMS PROPORTIONAL TO $C_{L\alpha}$ AND $C_{L\delta e}$

[Calculations made by analytic solution of the pitching- and normal-acceleration equations; values are given per unit elevator deflection]

Time, sec	Airplane A			Airplane B			Airplane C		
	A (a)	B (b)	γ (c)	A (a)	B (b)	γ (c)	A (a)	B (b)	γ (c)
0	0	0	0	0	0	0	0	0	0
1	-.64	.04	-.60	-.37	.09	-.28	-.52	.13	-.39
2	-1.11	.08	-1.03	-.55	.19	-.36	-.81	.27	-.54
3	-1.97	.12	-1.85	-.89	.28	-.61	-1.48	.42	-1.06
4	-2.92	.16	-2.76	-1.31	.37	-.94	-2.02	.53	-1.49

$$a \quad A = - \frac{VC_{L\alpha}}{2\mu\bar{c}} \frac{V^2 C_{m\delta e}}{2\mu k_y^2} \left[\frac{\lambda_2^2 e^{\lambda_1 t} - \lambda_1^2 e^{\lambda_2 t}}{b^2 \sqrt{a^2 - 4b}} - \left(\frac{t}{b} - \frac{a}{b^2} \right) \right]$$

$$b \quad B = \frac{VC_{L\delta e}}{2\mu\bar{c}} \left(\frac{a}{b} + \frac{\lambda_2^2 e^{\lambda_1 t} - \lambda_1^2 e^{\lambda_2 t}}{b \sqrt{a^2 - 4b}} \right) + \frac{VC_{L\delta e}}{2\mu\bar{c}} \frac{V^2 C_{m\alpha}}{2\mu k_y^2} \left[\frac{\lambda_2^2 e^{\lambda_1 t} - \lambda_1^2 e^{\lambda_2 t}}{b^2 \sqrt{a^2 - 4b}} - \left(\frac{t}{b} - \frac{a}{b^2} \right) \right]$$



$$c \quad \gamma = A + B.$$

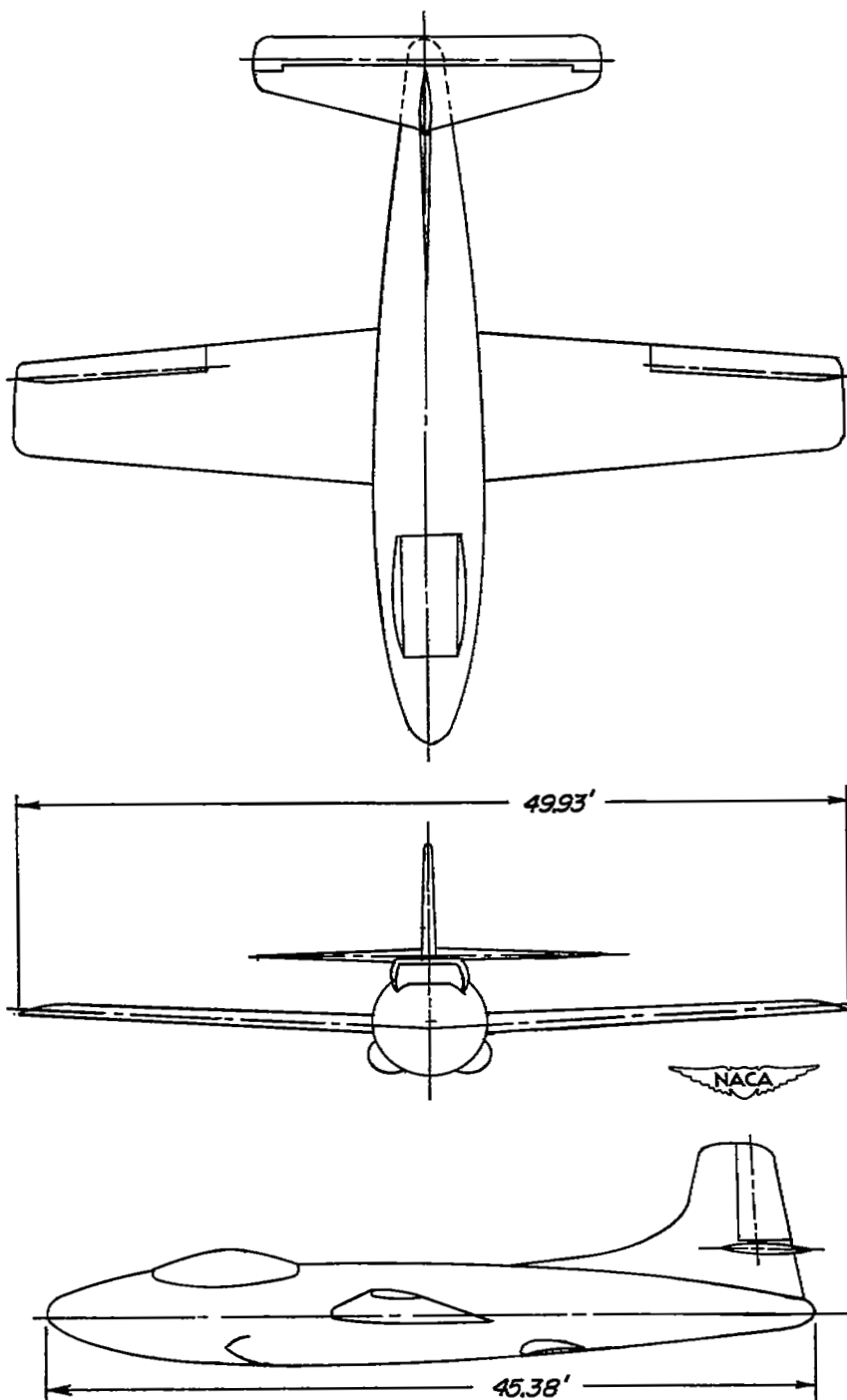

(a) Airplane A.

Figure 2.- Three-view drawings of airplanes investigated.

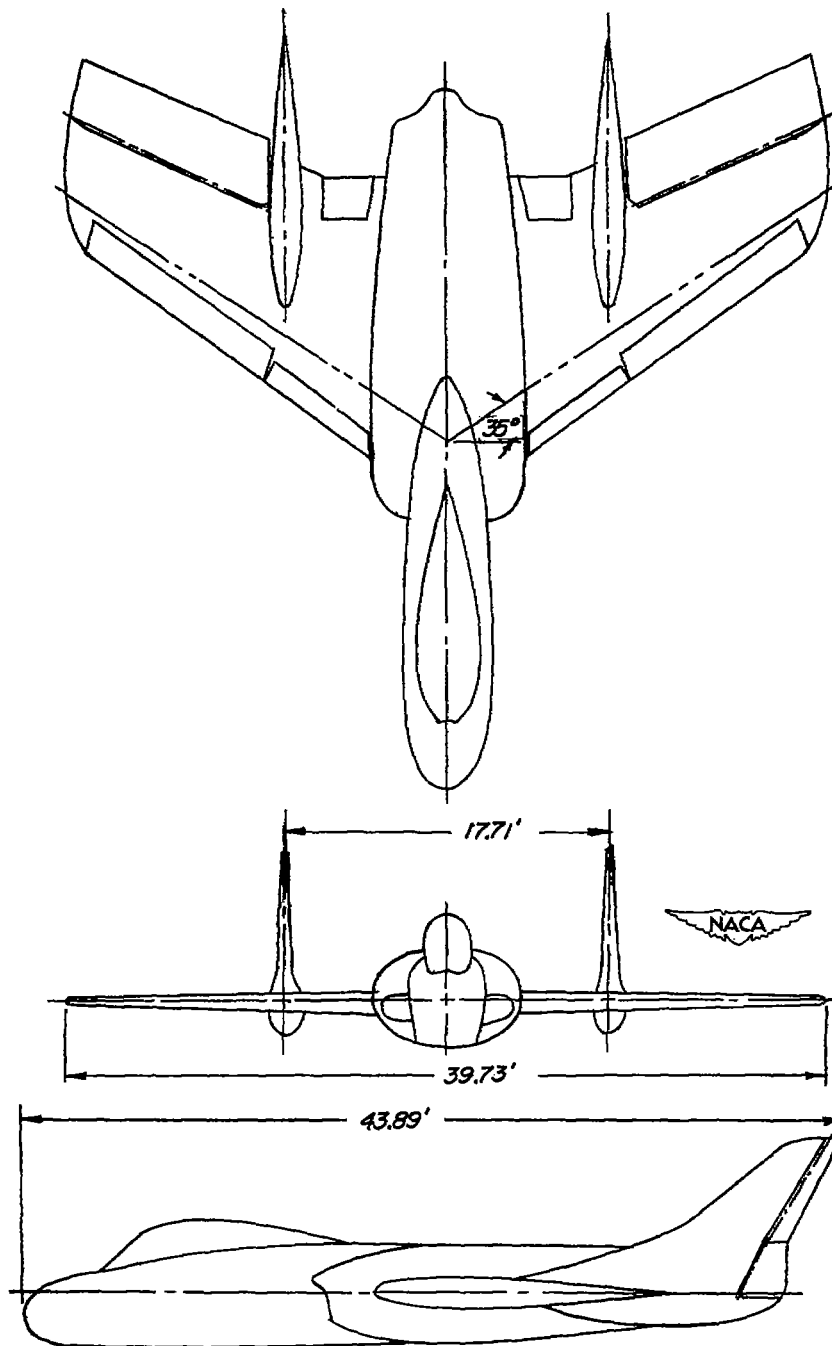

(b) Airplane B.

Figure 2.- Continued.

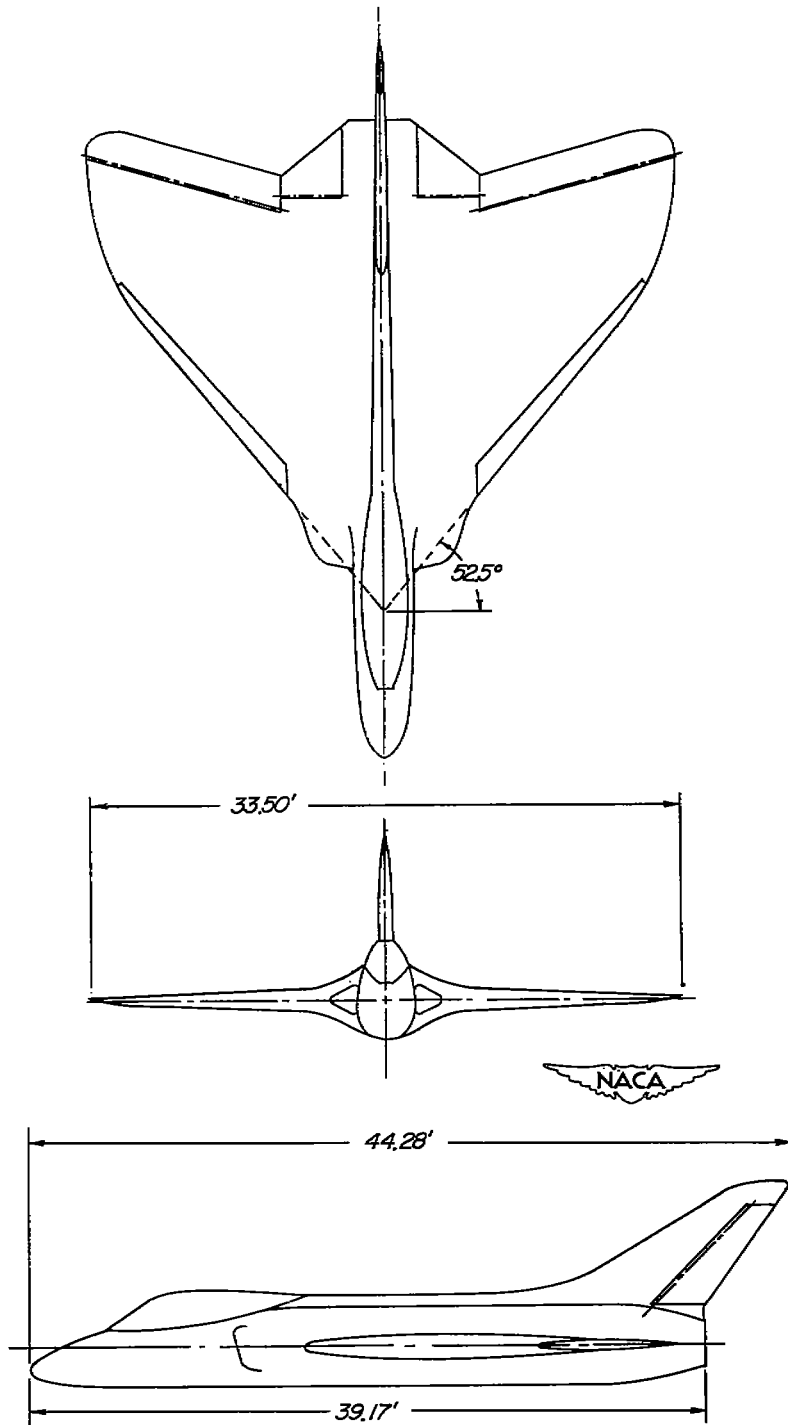

(c) Airplane C.

Figure 2.- Concluded.

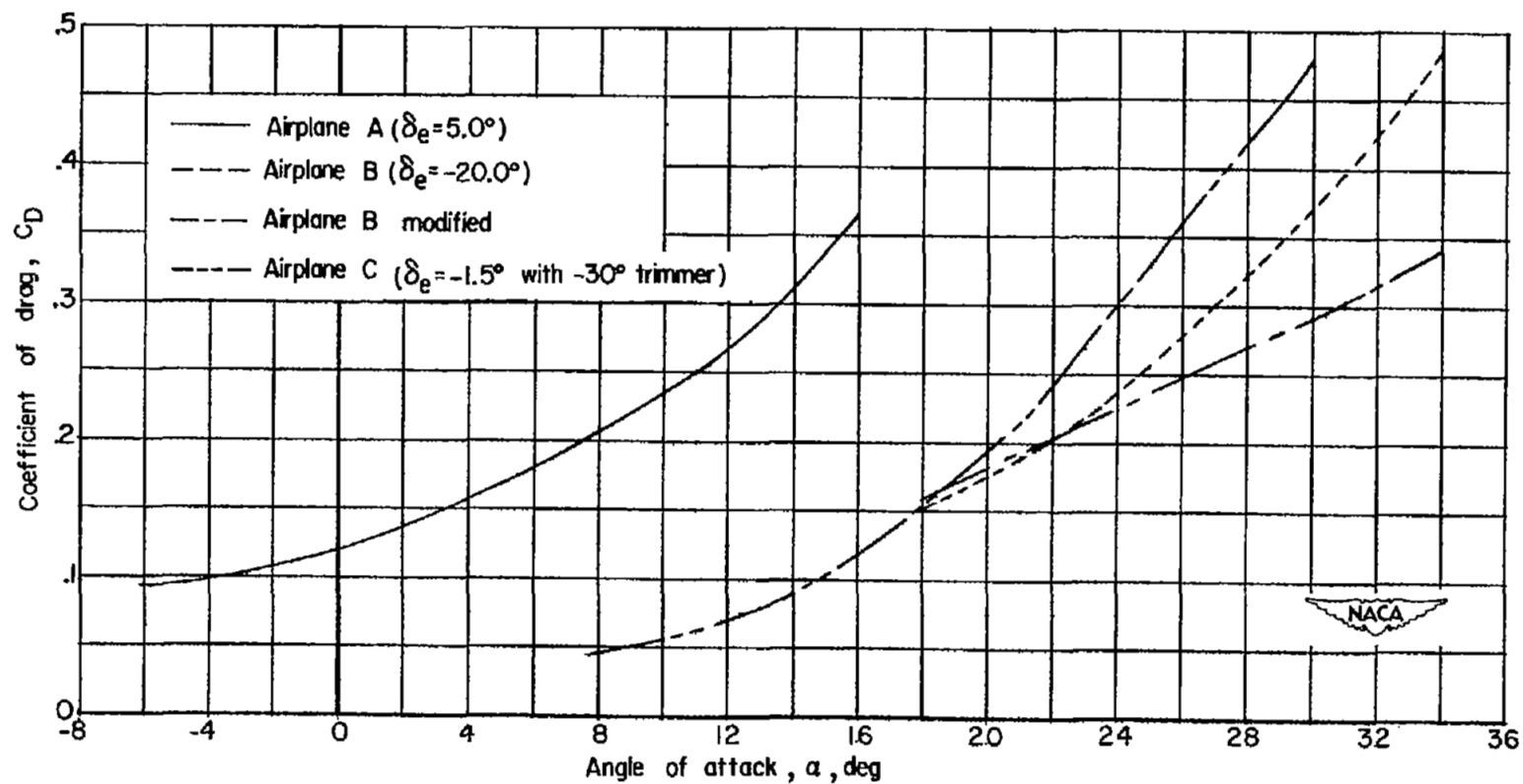
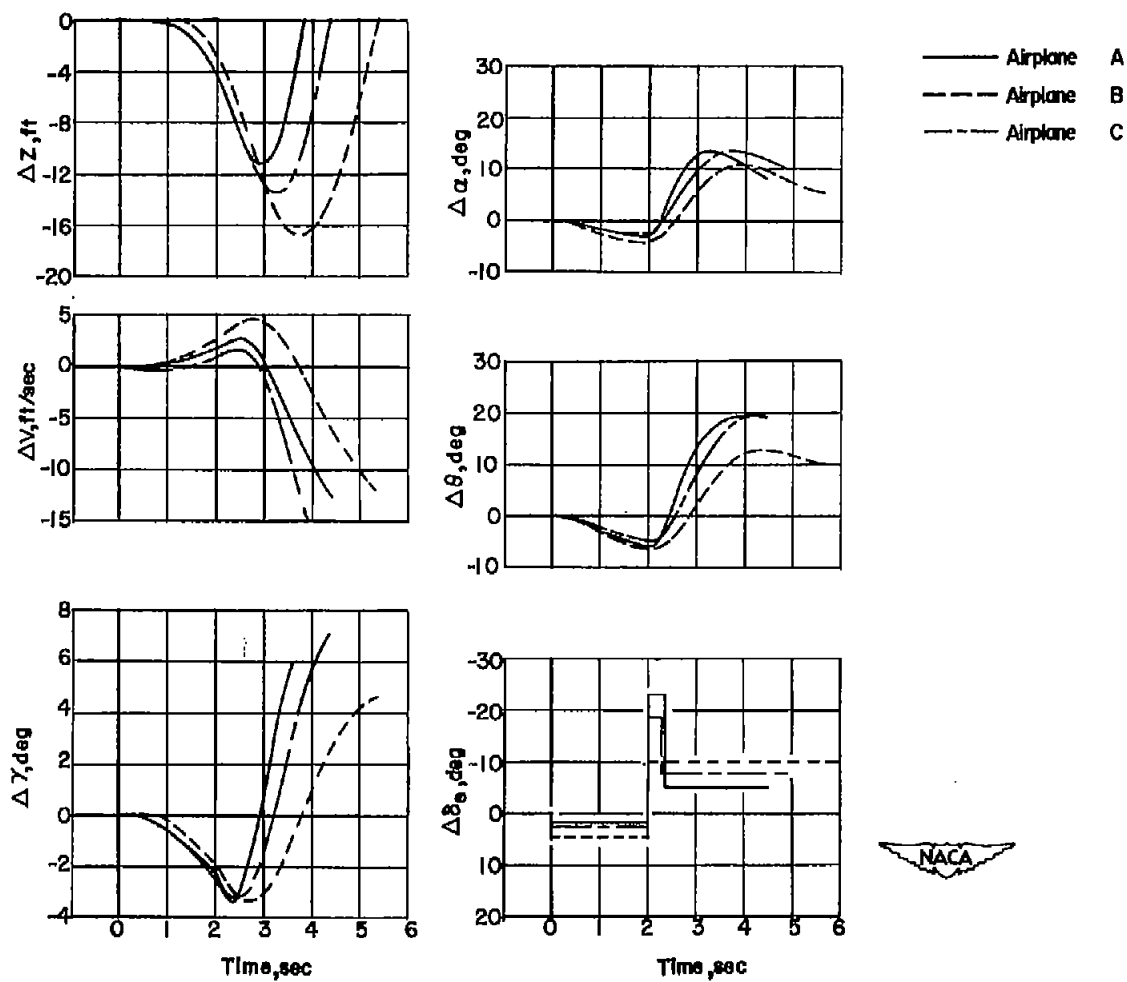
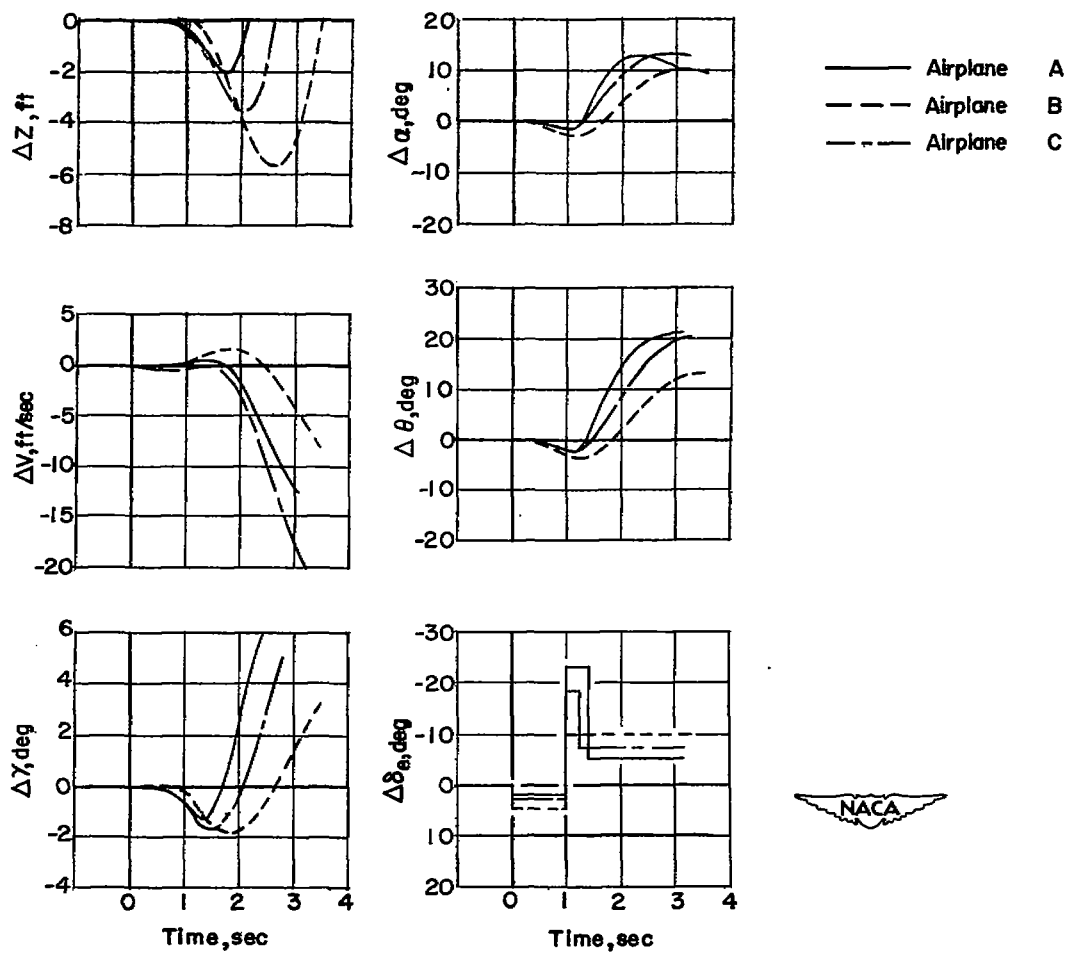

Figure 3.- Variation of drag coefficient with angle of attack for airplanes A, B, and C.



(a) Pull-up after 2 seconds.

Figure 4.- Comparison of response to available longitudinal control on airplanes A, B, and C. Initial trim values given in table II.



(b) Pull-up after 1 second.

Figure 4.- Concluded.

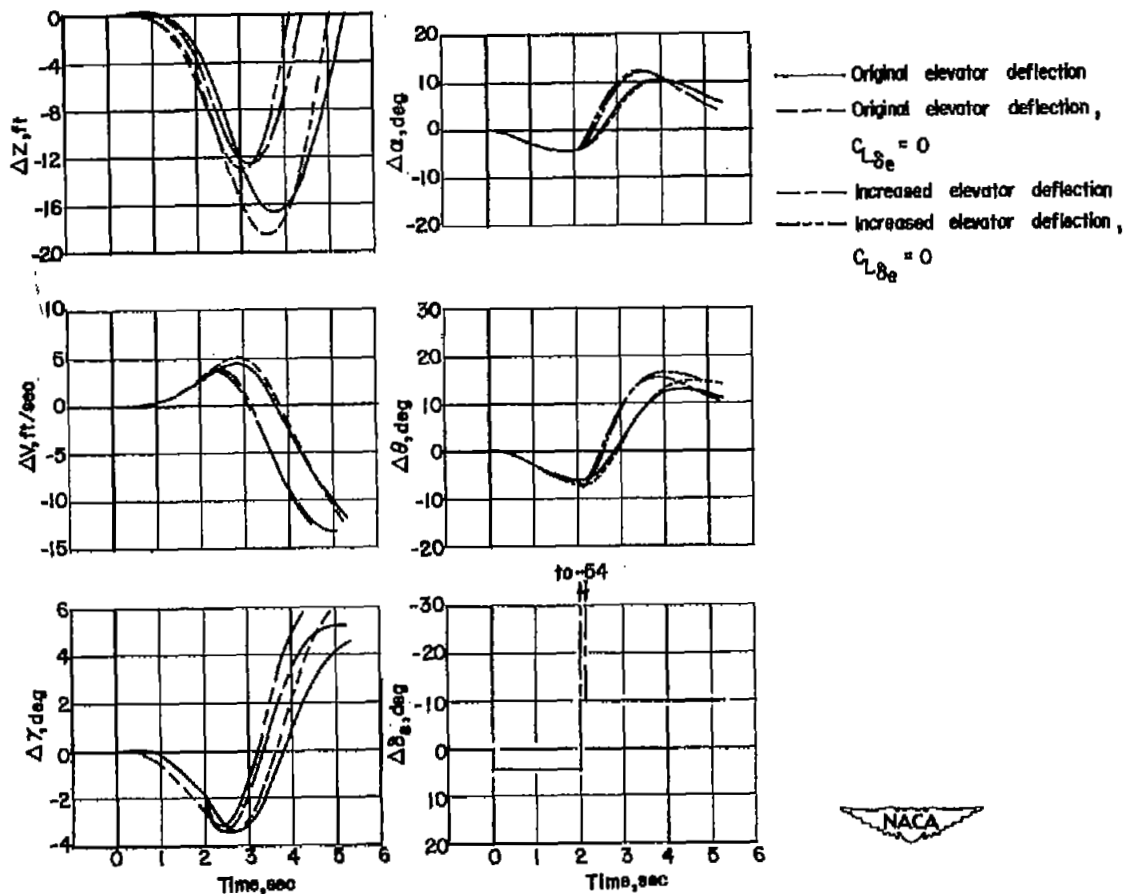

(a) Pull-up after 2 seconds.

Figure 5.- Effect of increasing up-elevator deflection, of eliminating the change of lift due to elevator deflection, and combination of both on the response of airplane B. Initial trim values given in table II.

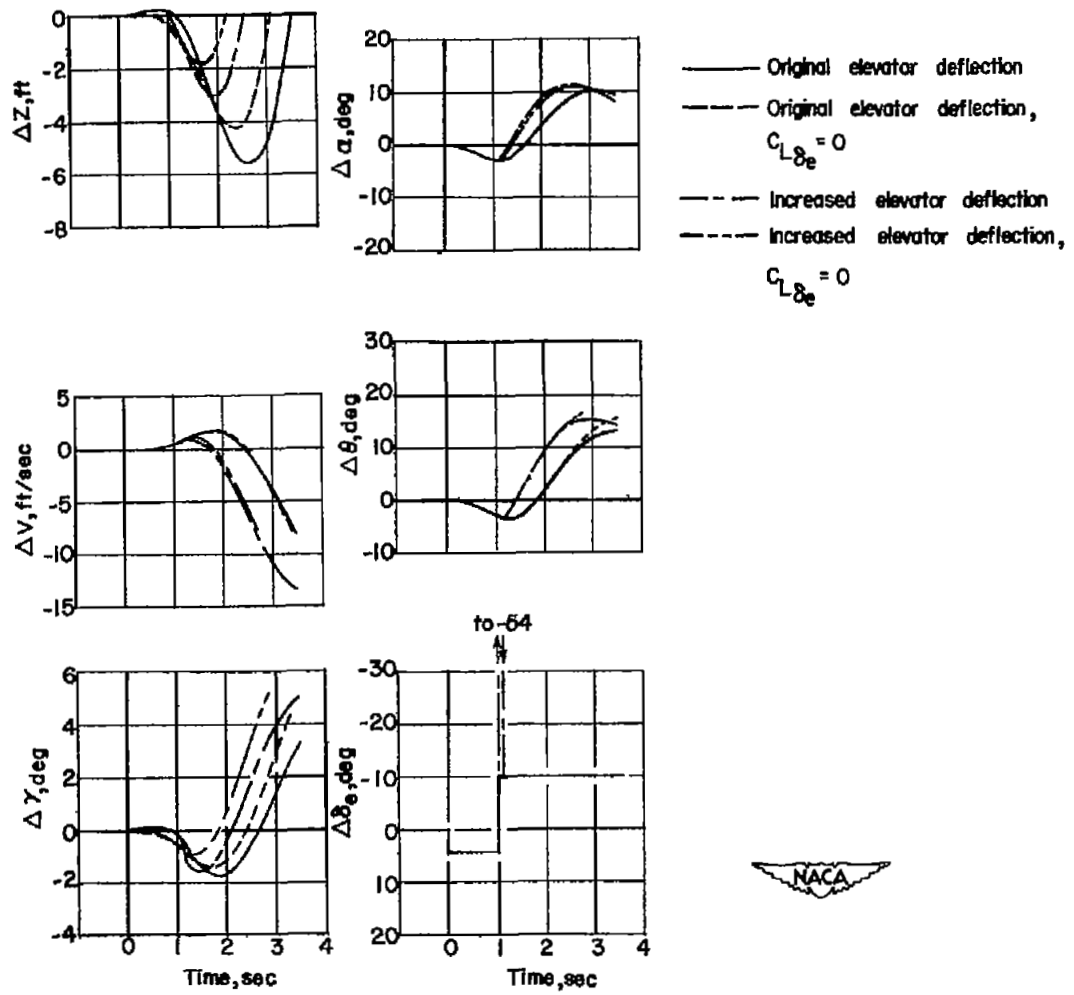

(b) Pull-up after 1 second.

Figure 5.- Concluded.

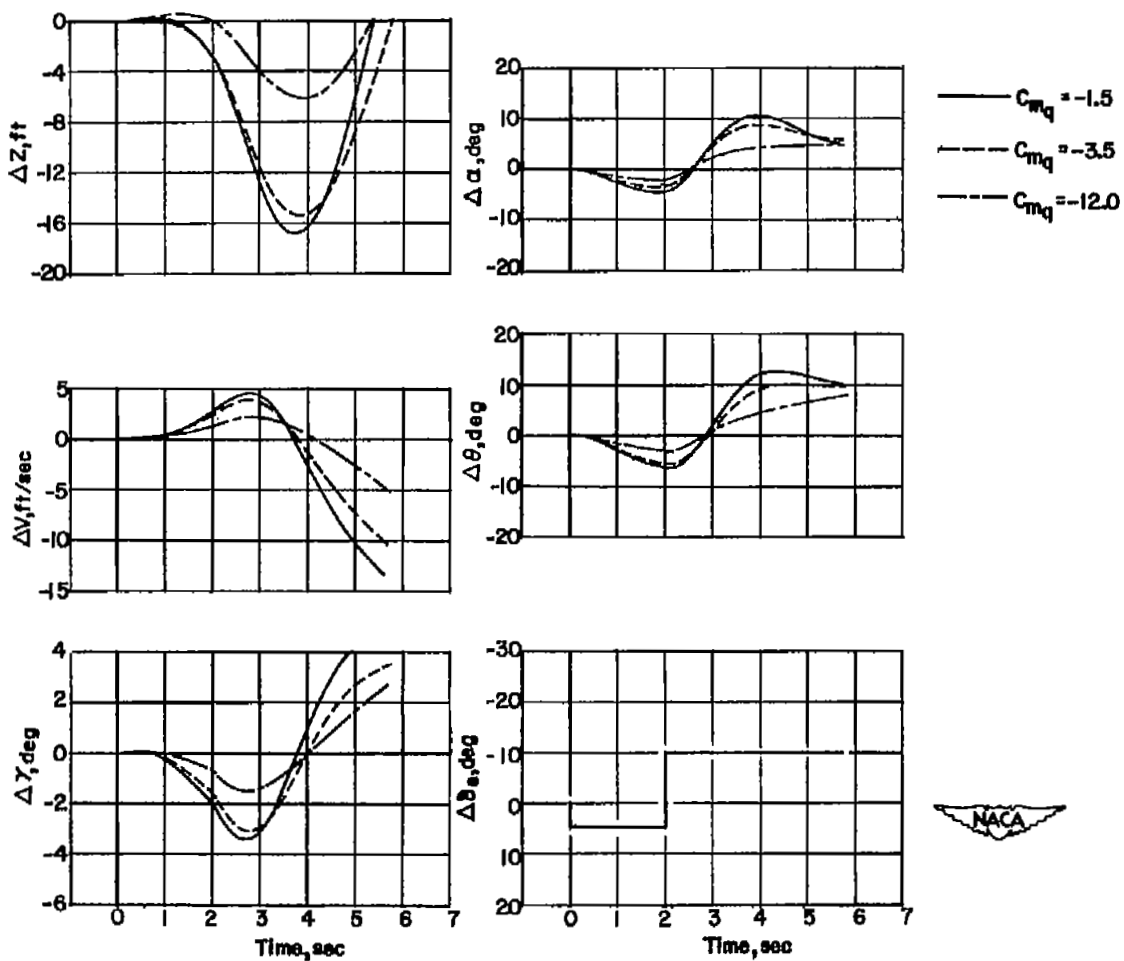

(a) Pull-up after 2 seconds.

Figure 6.- Effect of varying C_{mq} on response of airplane B. Initial trim values given in table II.

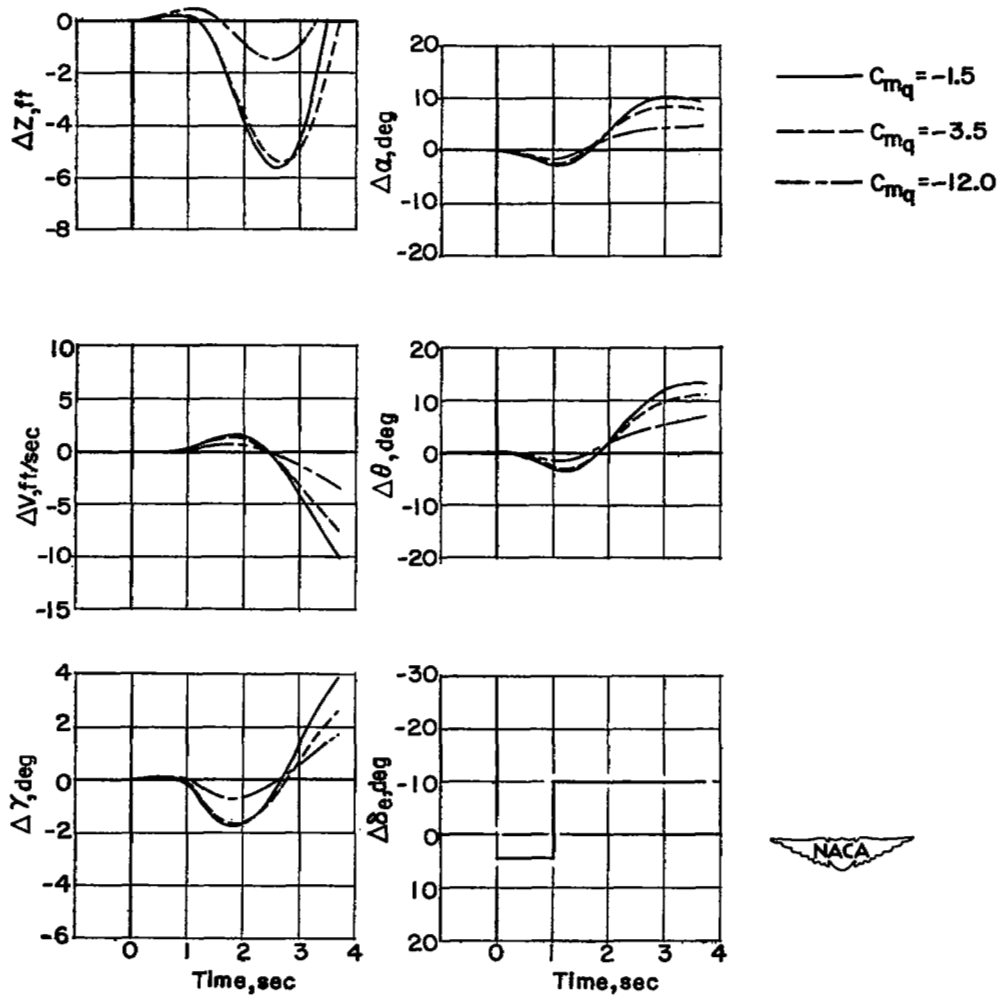

(b) Pull-up after 1 second.

Figure 6.- Concluded.

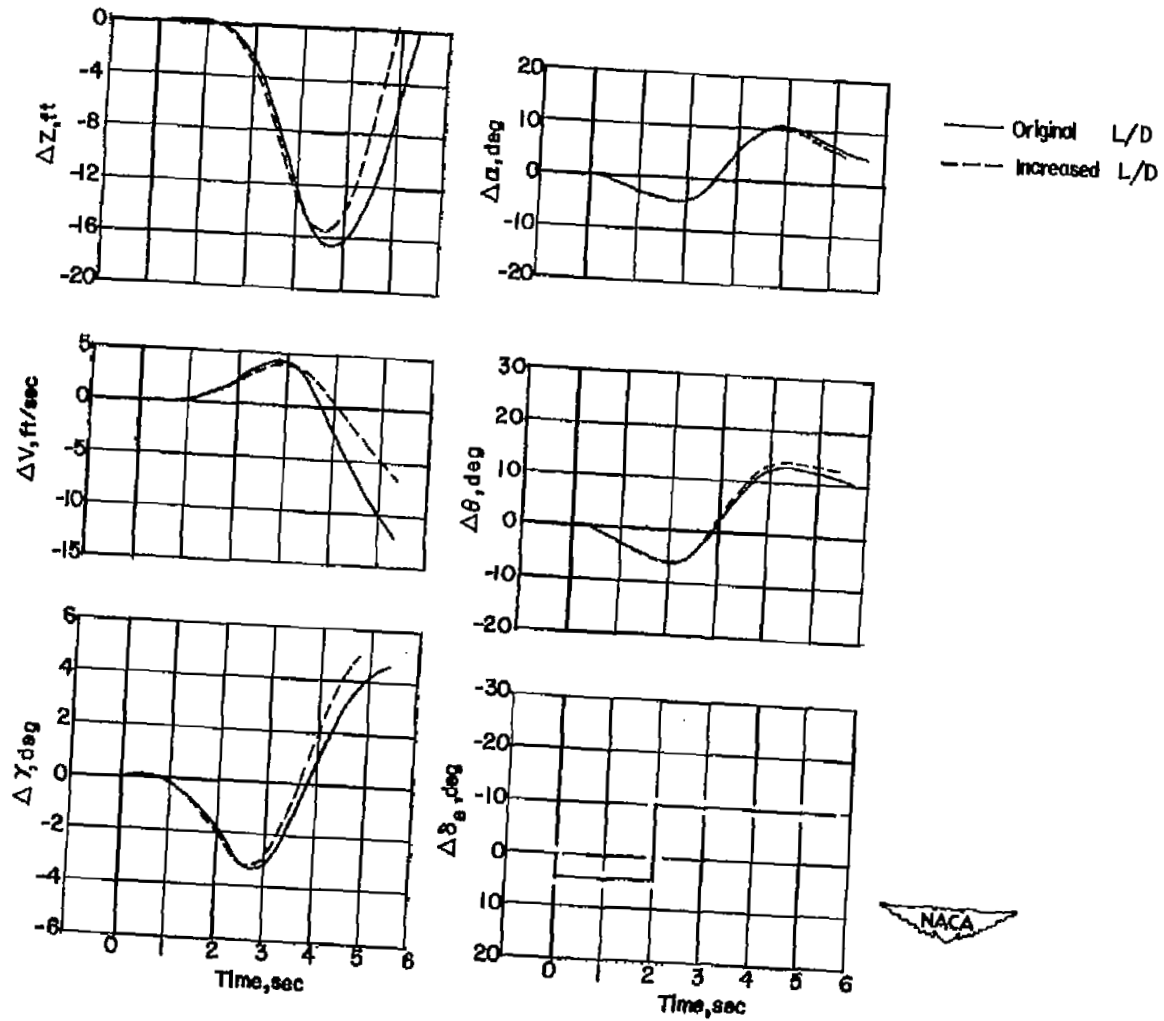

(a) Pull-up after 2 seconds.

Figure 7.- Effect of increasing L/D on response of airplane B. Initial trim values given in table II.

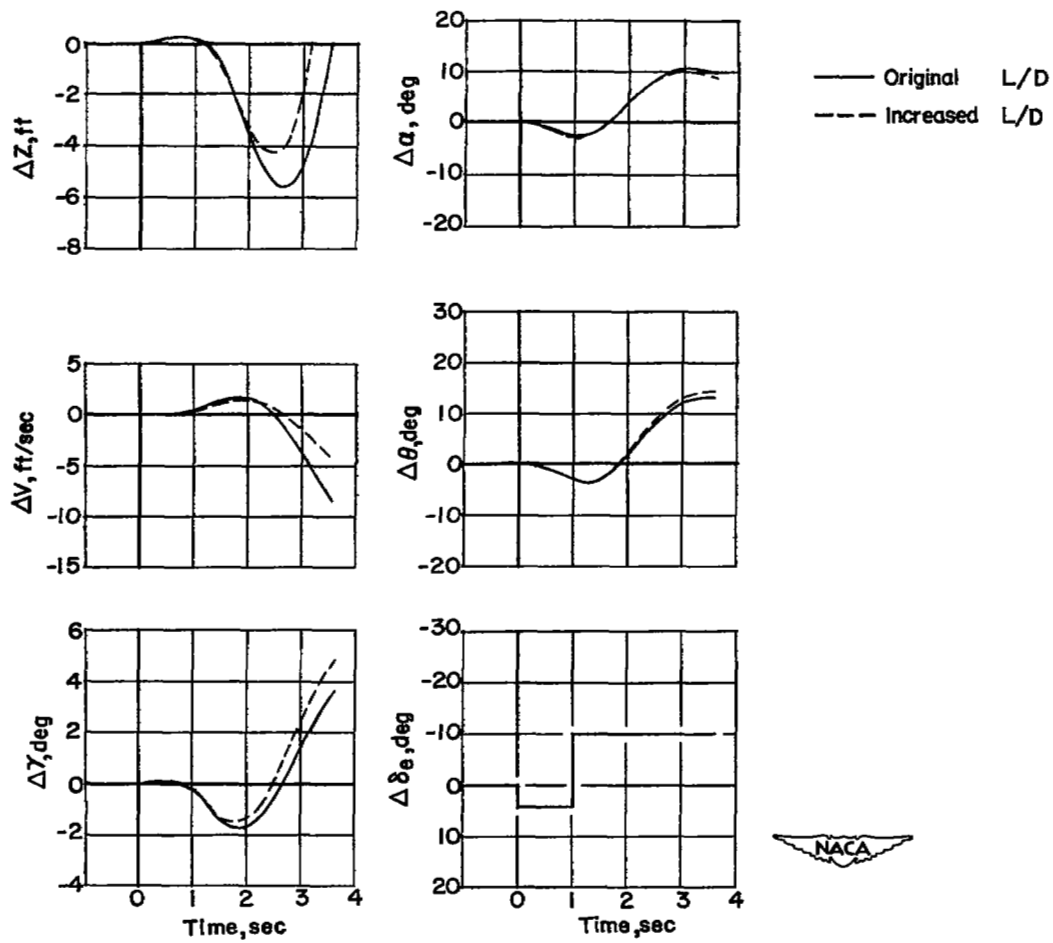

(b) Pull-up after 1 second.

Figure 7.- Concluded.

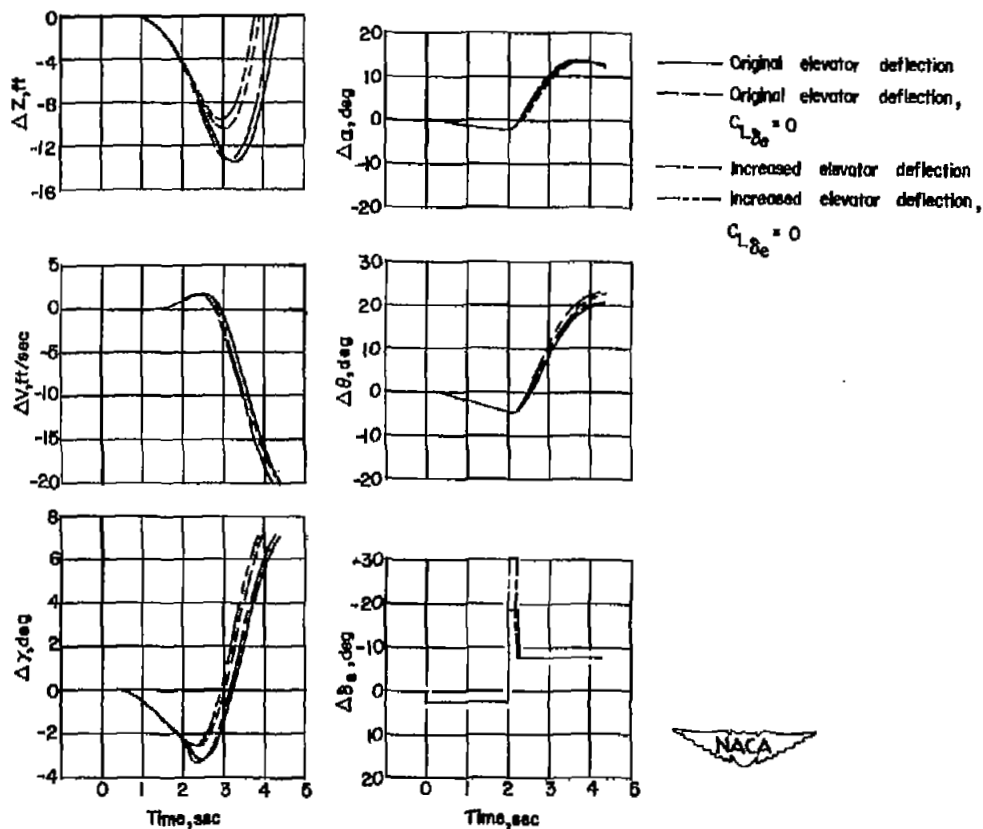

(a) Pull-up after 2 seconds.

Figure 8.- Effect of increasing up-elevator deflection, of eliminating the change of lift due to elevator deflection, and combination of both on the response of airplane C. Initial trim values given in table II.

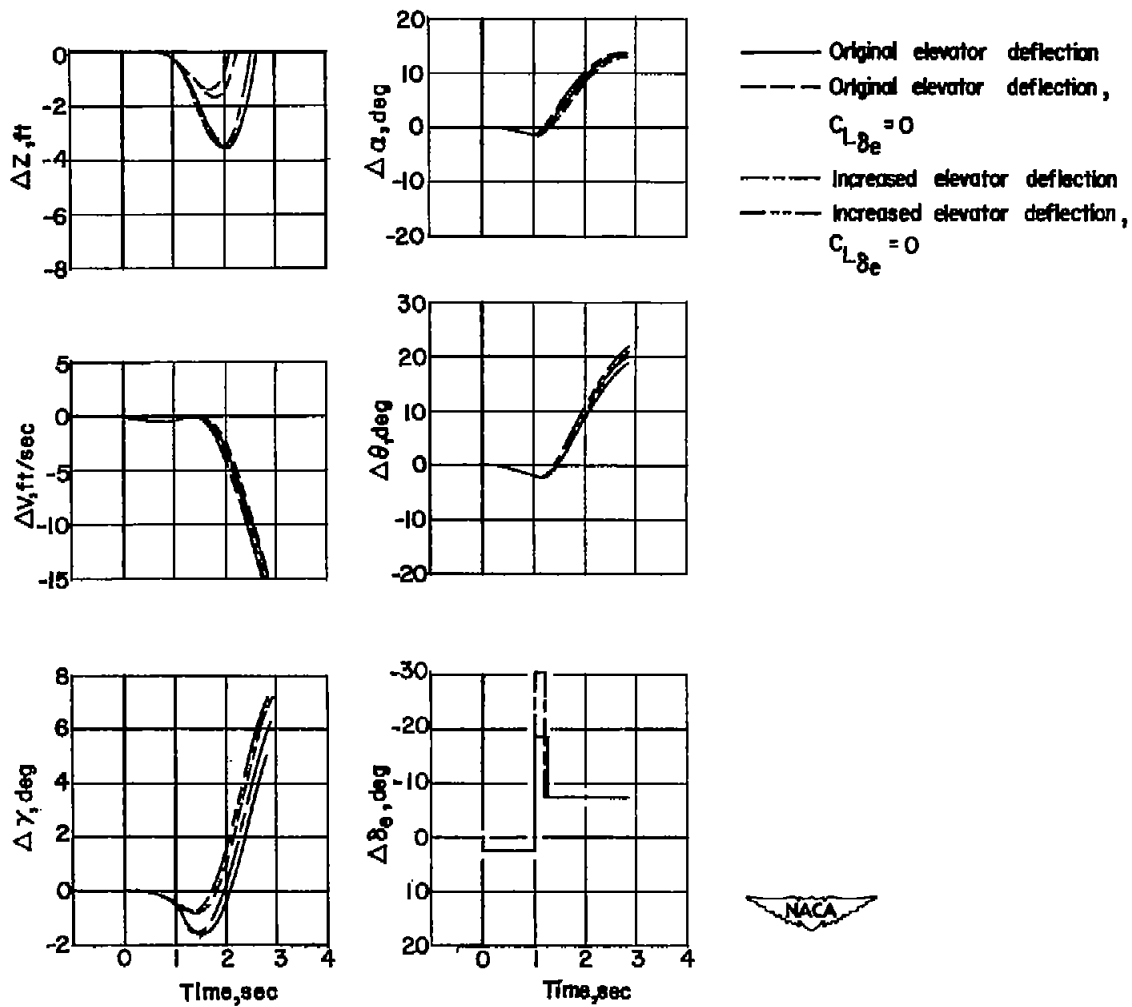

(b) Pull-up after 1 second.

Figure 8.- Concluded.

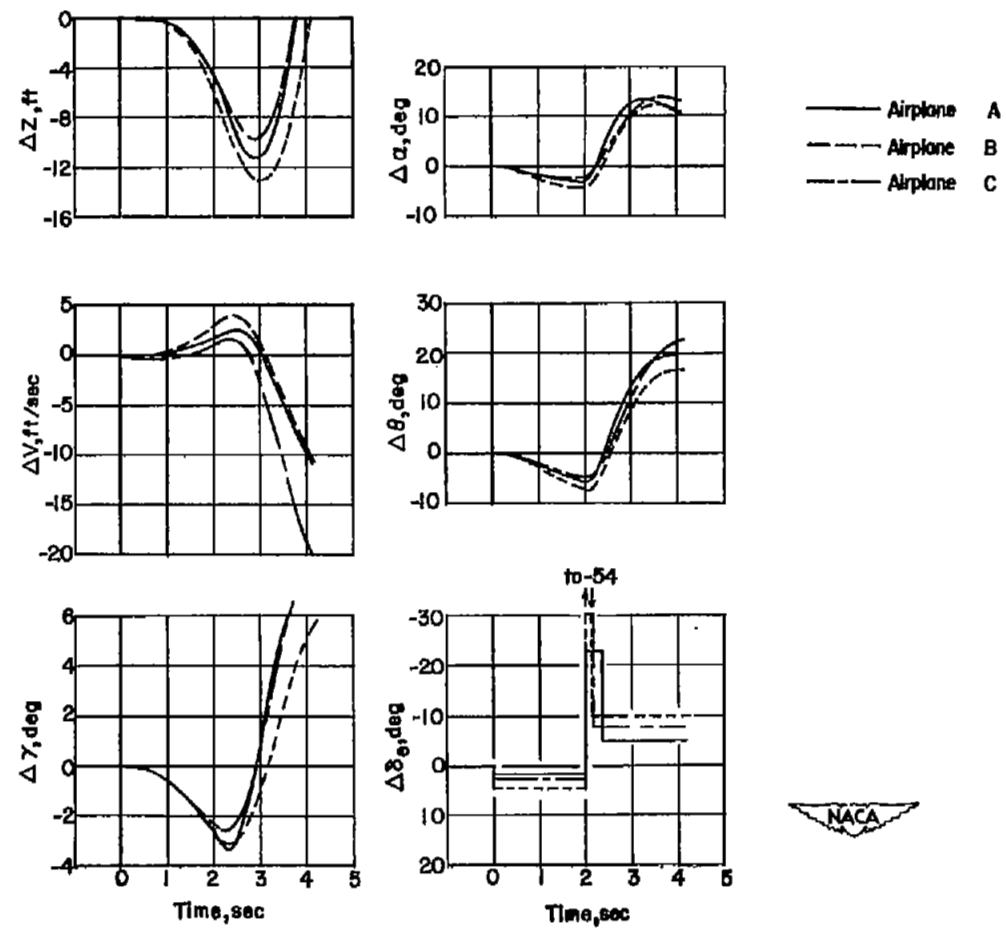

(a) Pull-up after 2 seconds.

Figure 9.- Comparison of response to longitudinal control on airplanes A, B, and C. Airplanes B and C had increased up-elevator deflection and the change in lift due to elevator deflection eliminated. Initial trim values given in table II.



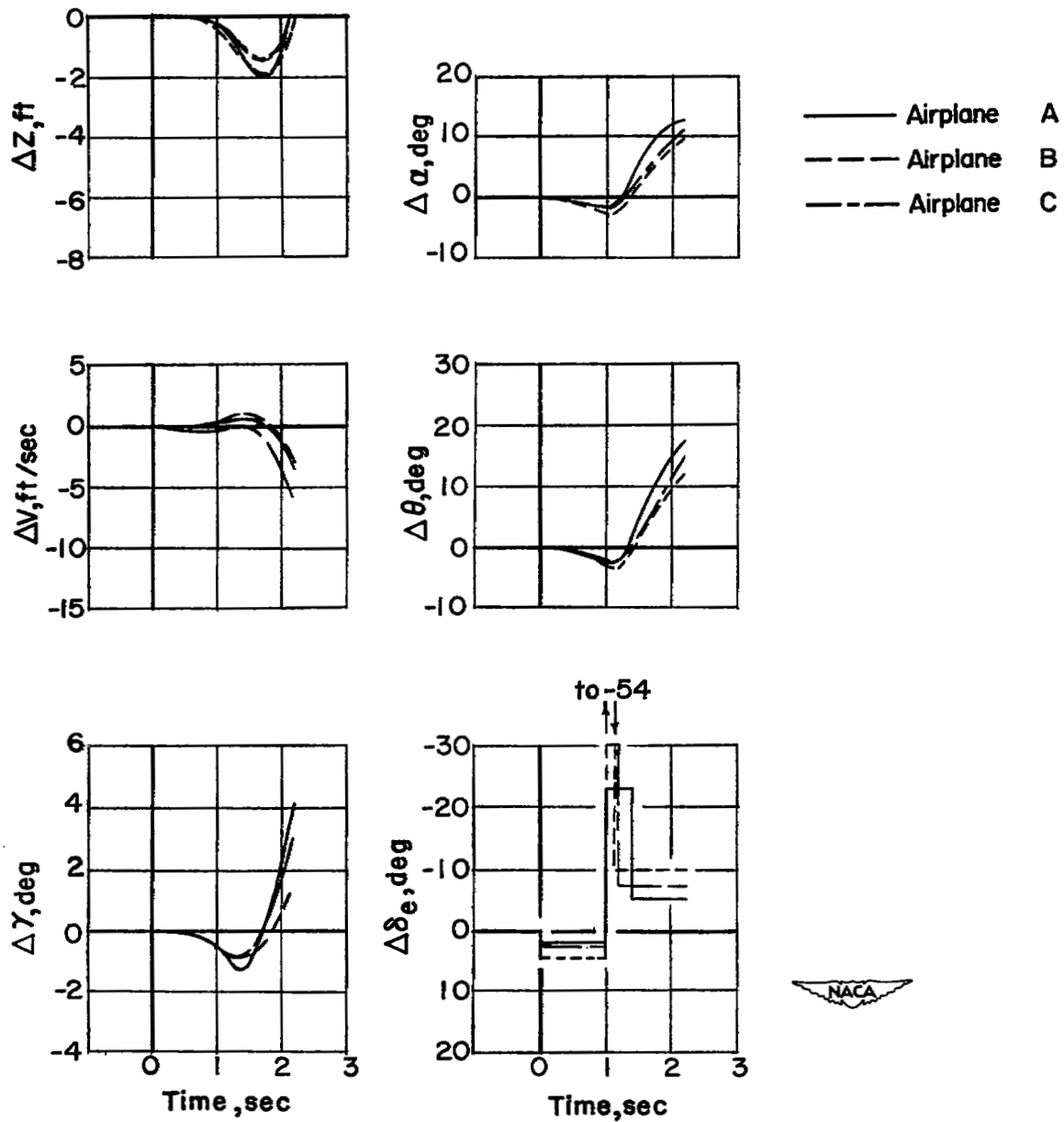

(b) Pull-up after 1 second.

Figure 9.- Concluded.

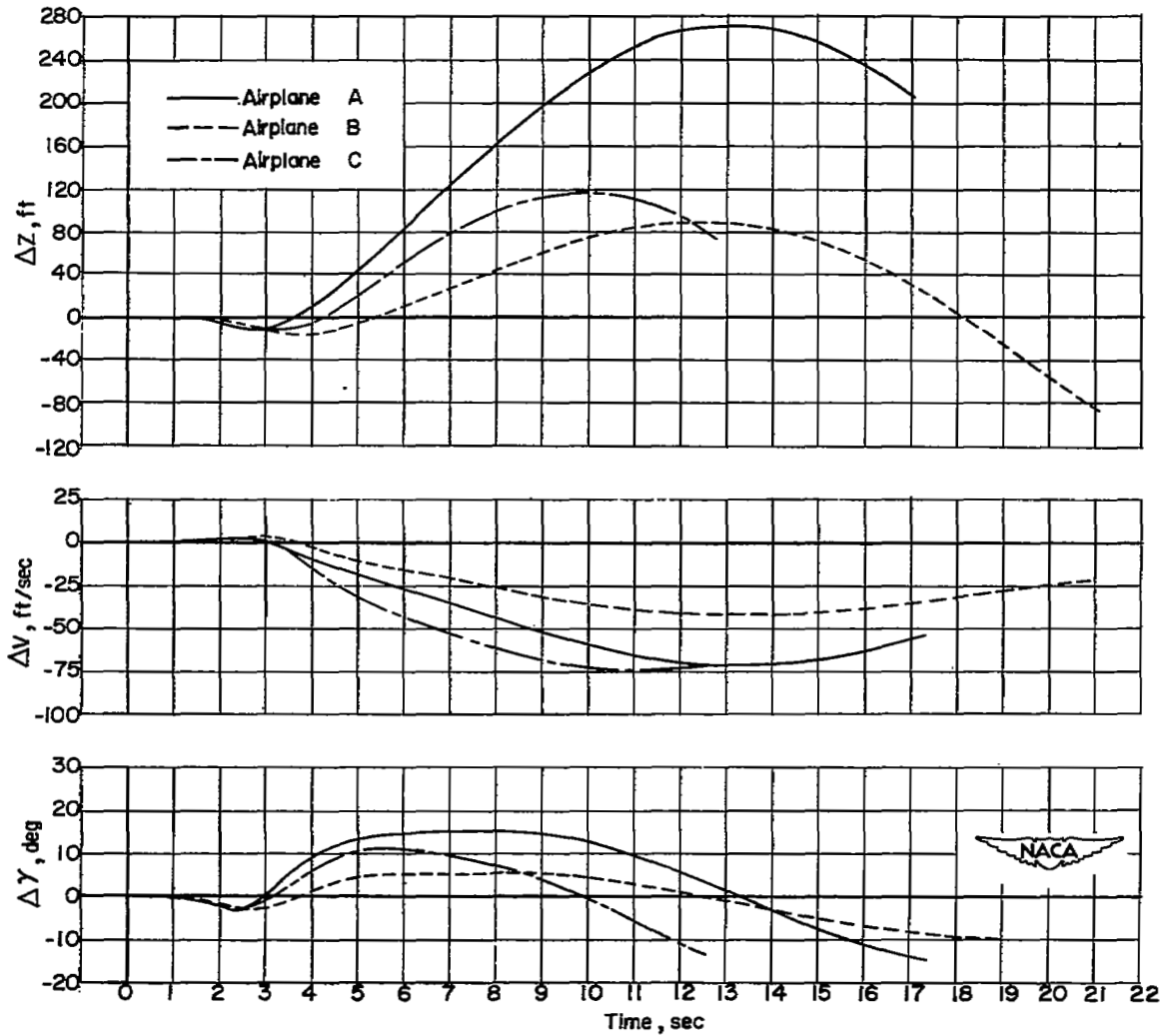

Figure 10.- Comparison of response to available longitudinal control on airplanes A, B, and C for a long period of time. Initial trim values given in table II.

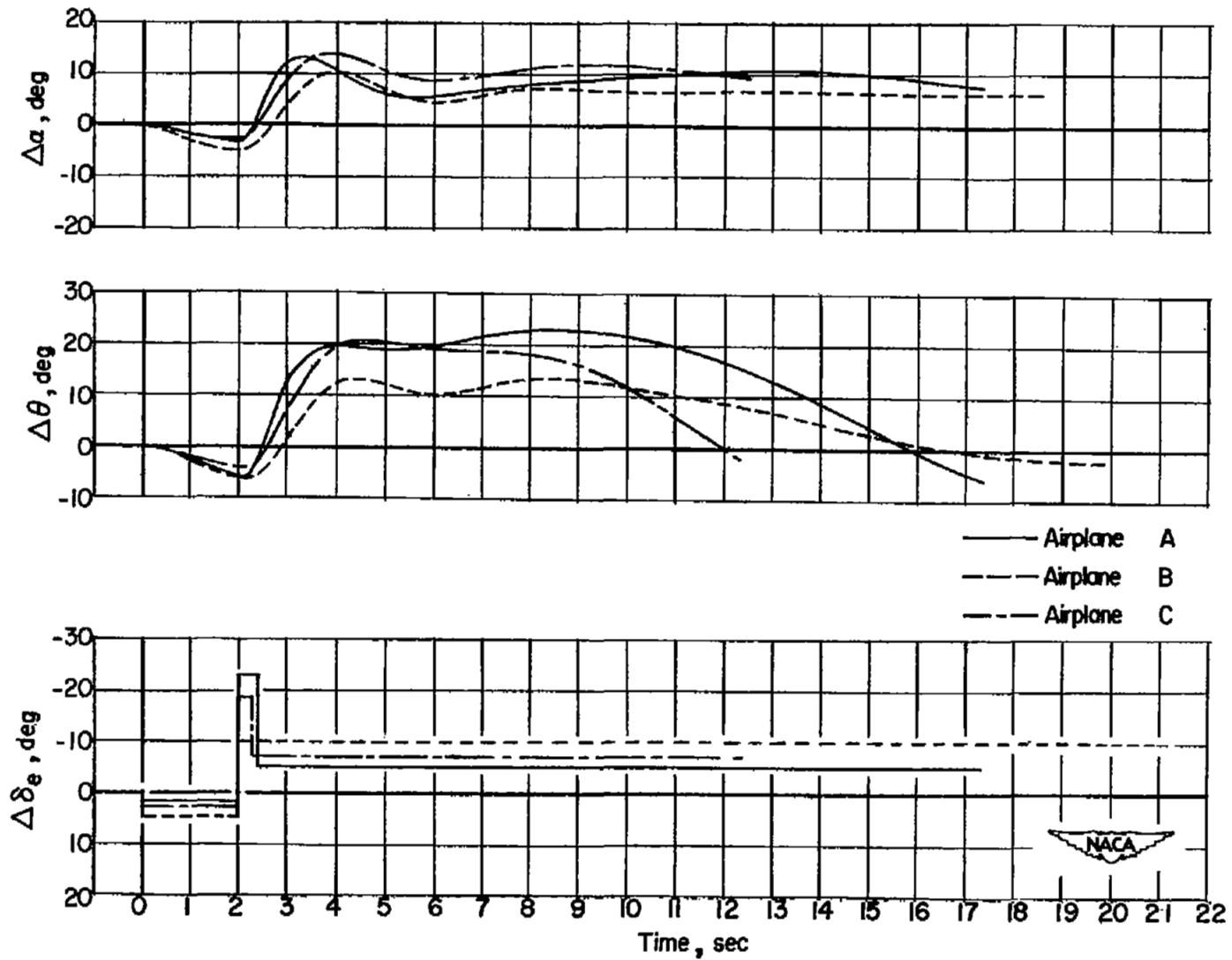

Figure 10.- Concluded.

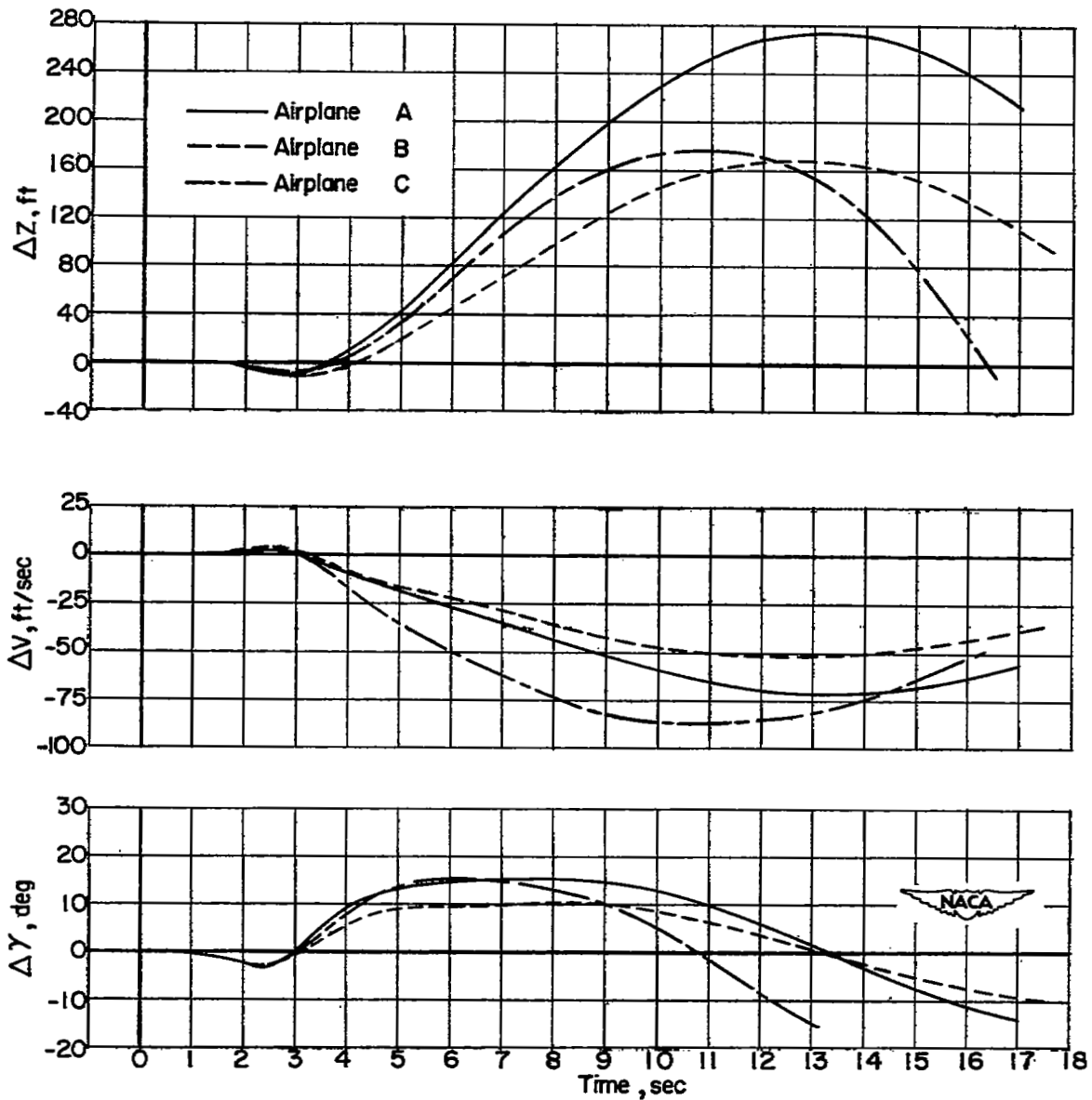

Figure 11.- Comparison of response to longitudinal control on airplanes A, B, and C for a long period of time. Airplanes B and C had increased up-elevator deflection and the change in lift due to elevator deflection eliminated. Initial trim values given in table II.

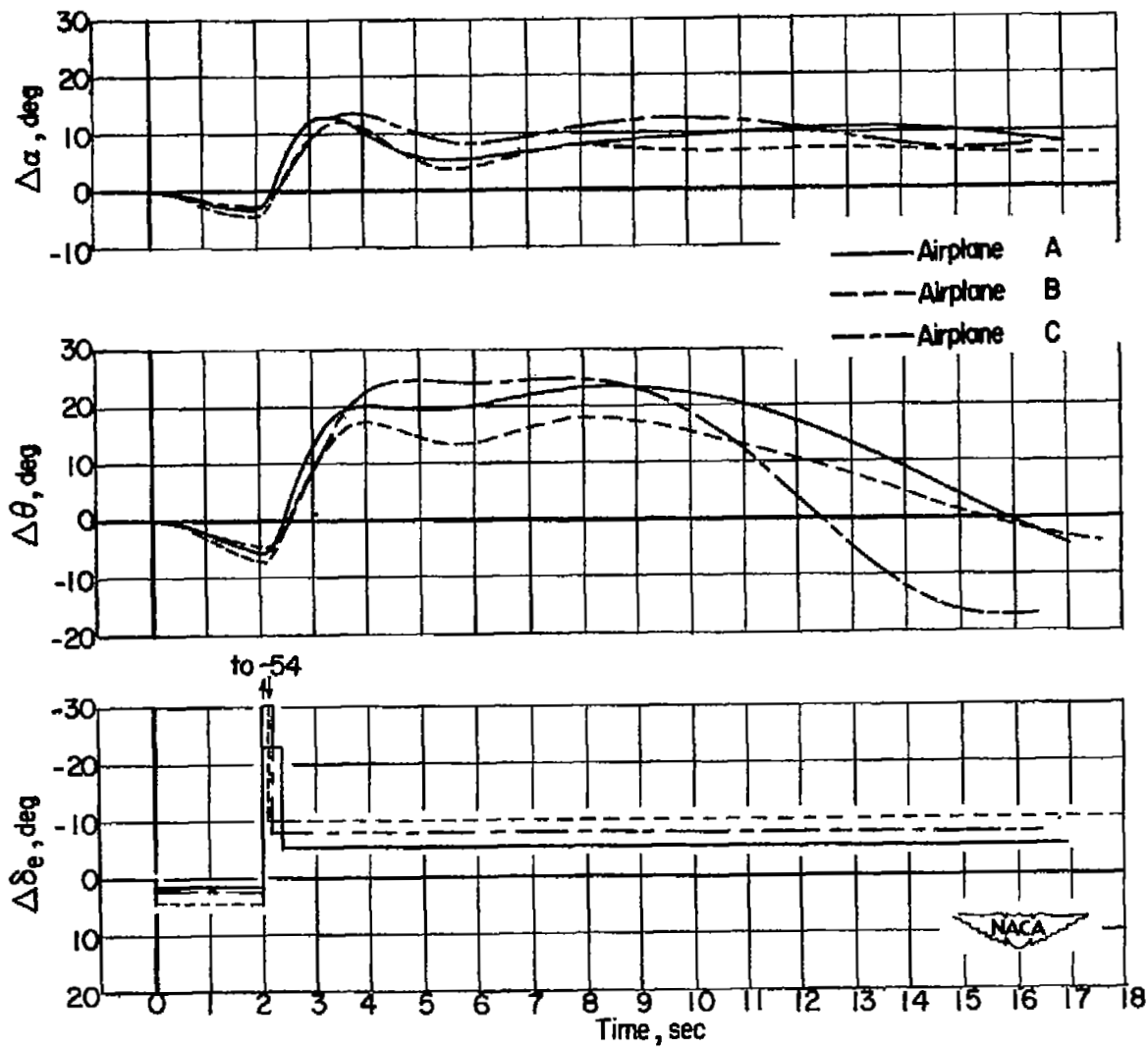

Figure 11.- Concluded.