

RM L53E18a



RESEARCH MEMORANDUM

DISCUSSION OF THREE-DIMENSIONAL OSCILLATING AIR FORCES

BASED ON WIND-TUNNEL MEASUREMENTS

By Sherman A. Clevenson, Sumner A. Leadbetter
and Weimer J. Tuovila

Langley Aeronautical Laboratory
Langley Field, Va.

**NATIONAL ADVISORY COMMITTEE
FOR AERONAUTICS
WASHINGTON**

June 30, 1953
Declassified September 1, 1959

NATIONAL ADVISORY COMMITTEE FOR AERONAUTICS

RESEARCH MEMORANDUM

DISCUSSION OF THREE-DIMENSIONAL OSCILLATING AIR FORCES

BASED ON WIND-TUNNEL MEASUREMENTS

By Sherman A. Clevenson, Sumner A. Leadbetter
and Weimer J. Tuovila

SUMMARY

The results of an exploratory investigation are presented, including a limited amount of data on oscillating air forces and moments through the subsonic and transonic speed ranges. Comparisons of the coefficients tabulated by Lawrence and Gerber for the forces, moments, and their respective phase angles with the experimental data on a rectangular and a delta wing of aspect ratio 2 showed good agreement. The magnitudes of the forces and moments were found to be generally nearly invariant with reduced frequency k for small values of k . The phase angles, however, were found to vary considerably with reduced frequency.

INTRODUCTION

Experimental determination of the oscillating air forces in the high subsonic speed range for wings of finite aspect ratio is desirable because of a lack of available data, both theoretical and experimental. The purpose of this paper is to present some current results of experiments in the Langley 2- by 4-foot flutter research tunnel and the Langley 16-foot transonic tunnel on wings of finite aspect ratio with and without tip tanks at subsonic and transonic speeds. Inasmuch as the oscillatory aerodynamic coefficients for delta and rectangular wings of small aspect ratio in incompressible flow have recently been tabulated by Lawrence and Gerber (ref. 1), the results of the experimental investigation discussed in this paper are compared with those of reference 1.

SYMBOLS

$$|l_\alpha| = \frac{|L|}{qS|\alpha|}$$

$$|m_{\alpha}| = \frac{|M|}{qS|\alpha|c/2}$$

θ_l	phase angle by which the lift leads the angle of attack
θ_m	phase angle by which the moment leads the angle of attack; negative values indicate that the moment lags the angle of attack
$ L , M , \alpha $	maximum values of lift, moment, and angle of attack respectively during a cycle of oscillation
c	root chord
S	area of the wing
q	dynamic pressure
k	reduced frequency
A	aspect ratio

DISCUSSION

Wind-Tunnel Interference

The experimental determination of oscillating air forces is more difficult than that of steady forces; in addition, there is the problem of interpretation of the results as affected by such an item as wind-tunnel-wall interference, particularly at high subsonic and transonic speeds. For the two-dimensional case, these effects are discussed in reference 2. Before proceeding to the discussion of the current results, a brief illustration of wind-tunnel-wall effects for three-dimensional flow may be in order. Figure 1 shows the amplitude of the lift coefficient and damping-moment coefficient, referred to the midchord line, as a function of Mach number. These data were obtained on a rectangular wing of aspect ratio 2 mounted perpendicular to the tunnel wall on a plate that oscillated in the same wall as shown in the figure. The wing was oscillated about its midchord line at a given frequency at various Mach numbers. The predicted critical tunnel resonance region for a two-dimensional wing is shown by the cross-hatched area. The circles represent the experimental results and the solid curves are the results of calculations by the method of Lawrence and Gerber. (The reason for the apparent variation of theoretical incompressible-flow results with Mach number is that, inasmuch as the frequency was held constant in the tests and the airspeed varied, the reduced frequency k , which is equal to the circular frequency multiplied by the semichord and divided by the airspeed,

varied with Mach number. This variation of k is responsible for the variation of the theoretical results with Mach number).

As can be seen, fairly good agreement exists between experiment and theory in the region well away from the critical resonance region, but large variations take place near this range, particularly in the damping moment. However, since in the region well away from critical resonance the data follow a consistent trend, it will be assumed that the effects of tunnel-wall interference in this region are small. Subsequent results in this paper were obtained well away from the critical resonant region, except where stated otherwise, by using either air or Freon-12 as required in any given case.

Rectangular Wing of Aspect Ratio 2

The first configuration to be discussed is the wing shown in figure 1. For this wing, figure 2 shows the amplitudes of the lift and moment coefficients and the angle by which these coefficients either lead or lag the position of the wing. A moment phase angle shown below the zero line indicates a damped moment. Shown here for comparison are the results of the incompressible-flow analysis of Lawrence and Gerber indicated by the solid curves and the results for two-dimensional incompressible flow (ref. 3) indicated by the dashed curves. The experimental data are shown by the circles. In this figure, these coefficients and phase angles are shown as a function of the reduced-frequency parameter k , but, as in figure 1, the test results pertain to a constant frequency and varying airspeeds and, hence, varying Mach numbers. The range of Mach number was from 0.30 corresponding to the point at the highest value of k to 0.78 for the point at the lowest value of k .

Although the calculations are for the incompressible case, they show fairly good agreement for this aspect ratio. The effect of aspect ratio can be observed by comparing experimental data with the results of two-dimensional theory and the theory for aspect ratio 2. The theoretical results for aspect ratio 2 fall close to the experimental data and follow the same trends for the four quantities shown, namely magnitudes of the lift and moment coefficients and phase angles of the lift and moment. Three-dimensional theory underestimates the magnitudes of the aerodynamic forces in this case, so that the use of these coefficients in a flutter analysis would tend to result in too high a calculated flutter speed and would thus be nonconservative. On the other hand, the two-dimensional theory overestimates the forces by a considerable amount and would tend to result in too low a calculated flutter speed, hence, over-design of the aircraft.

There is little variation in the magnitudes of the forces and moments at low values of k , although the phase angles, especially the lift phase

angles, do show considerable variation with k . Other experimental data, not shown, indicate that, even if the Mach number had not been varied as in these tests, these magnitudes would probably still show little variation. It thus appears that steady-state tests may be useful in predicting the magnitude of the oscillatory lift; however, the steady-state tests offer no information as to the phase angles, which may be equally important in a flutter analysis.

Delta Wing of Aspect Ratio 2

Figure 3 serves to show some effect of plan form at a given aspect ratio inasmuch as it contains the results of measurements of the lift and moment on a delta wing of aspect ratio 2, that is, a 63.4° delta wing oscillating about a line through the midpoint of the root chord and perpendicular to the plane of symmetry. The moments are again referred to the axis of rotation. As in the preceding figure, the results are plotted against k , and again each point represents a different Mach number.

The experimental parameters, lift, moment, and lift and moment phase angles, for this delta wing approximately follow the same trends as previously seen for the rectangular wing of aspect ratio 2. The phase angle again indicates a damped moment. It will be noted that the results of calculations by the method of Lawrence and Gerber for this plan form are in good agreement with the experimental results.

Wing With Tip Tanks

The use of large tanks at the tips of wings raises the question of how they affect oscillating air forces on the wing. The lift forces and phase angles have been obtained on a tank placed over the end of the rectangular wing of aspect ratio 2 as shown in figure 4. The wing extended into the tank approximately to its center line and there was a gap between the wing surface and the tank. The tank was attached to the wing tip through a strain-gage dynamometer, so that the tank forces could be separated from the total forces on the combination. The wing-tank combination was oscillated as a unit about the wing midchord axis.

In figure 4, lift magnitudes and phase angles are shown as functions of the reduced frequency. For comparison, the results of calculations by the method of Lawrence and Gerber for a rectangular wing of aspect ratio 2 without tip tanks are shown by the solid curves. The coefficients are all based on the same reference area, namely the area of the original wing alone. For reference, the dashed line represents a faired curve through the experimental data presented in figure 2 for the wing alone. From a comparison of this dashed curve with the square test points which represent the wing force in the presence of the tank, it may be seen that the

addition of a tank to the wing tip does not increase the lift coefficient on the wing proper by a significant amount. If the comparison of these coefficients were made by taking into account only the exposed area, the lift coefficient on the wing in the presence of the tank would be increased by approximately 25 percent.

The lift on the tank was found to be about one-fourth the total lift on the wing-tank configuration for this low aspect ratio. The phase angles for the wing-tank combination and for the tank in the presence of the wing are about zero at reduced frequencies below 0.2, as are the phase angles for the wing in the presence of the tank. At somewhat higher reduced frequencies, the phase angles of the total lift on the wing-tank combination are consistently smaller than the phase angles on the wing alone and the phase angles on the tank in the presence of a wing are smaller still, being about one-half as large as those for the lift phase angle on the wing alone. From the given lift magnitudes and phase angles, the phase angle of the lift on the wing in the presence of the tank can be deduced and is found to be slightly less than that of the lift phase angle on the wing alone.

Rectangular Wing on Free-Fall Body

A region of great importance today is the transonic speed range. Some exploratory tests have been made in the Langley 16-foot transonic tunnel with a rectangular wing mounted on the forward portion of a free-fall body as shown in figure 5. The two wing panels oscillated as a unit, whereas the body remained stationary. Tests involving oscillations about the 44-percent-chord station were conducted up to a Mach number of 1.074.

The oscillating forces, moments, and moment phase angles obtained are compared with theory in figure 5, the moments being referred to the axis of rotation. These coefficients are shown as a function of Mach number and reduced-frequency parameter. The experimental data for the oscillating case (28 cps) are shown by the square test points and for the static case, by the circles. The experimental data for the lift were obtained from strain gages which measured the bending moment at the root of one wing and are uncorrected for possible shifts in the spanwise center of pressure, so that they show trends rather than exact magnitudes.

These data were obtained through the critical tunnel resonance range mentioned previously in this paper but no particular resonant effects were noted, probably because of the fact that the Langley 16-foot transonic tunnel has a slotted throat, whereas the resonance data of reference 2 are based on the assumption of a two-dimensional closed throat.

Another factor that may be of importance is the ratio of tunnel height to wing chord. This model is a three-dimensional model with a ratio of tunnel height to wing chord of 16 as compared to the ratio of 4 for the wing shown in figure 1.

For comparison with the transonic experimental data, the results of two-dimensional compressible-flow theories (refs. 4 to 6) are shown in this figure by the dashed curves and the results of supersonic theory (ref. 7) for a rectangular wing of aspect ratio 3 are shown by the solid curves. The three crosses represent the calculations based on coefficients tabulated by Statler and Easterbrook (ref. 8) for a rectangular wing of aspect ratio 3 at a Mach number of 0.8. All theoretical curves pertain to 28 cps.

The experimental lift and moment coefficients may be seen to be much smaller than the theoretical two-dimensional compressible-flow coefficients and also slightly smaller than the results of supersonic theory. It is also interesting to note that the experimental oscillating coefficients are consistently smaller, although only by a small amount, than the experimental static coefficients. The phase angle of the moment remains negative through Mach number 1; this indicates a damped moment. The trend of moment phase angle predicted by two-dimensional theory toward an undamped region as the Mach number increases beyond 1 is thus not realized on wings of low aspect ratio in the Mach number region covered in these tests. Unfortunately no data were obtained at sufficiently high Mach numbers to indicate whether the abrupt change in phase angle predicted by three-dimensional supersonic theory is valid.

CONCLUDING REMARKS

This paper has dealt with a preliminary, exploratory investigation and has presented a limited amount of data through the subsonic and transonic speed ranges on oscillating air forces. Comparisons of the coefficients tabulated by Lawrence and Gerber for the forces, moments, and their respective phase angles with the experimental data on a rectangular and a delta wing of aspect ratio 2 showed good agreement. The magnitudes of the forces and moments were found to be generally nearly invariant with reduced frequency k for small values of k . The phase angles, however, were found to vary considerably with reduced frequency.

Langley Aeronautical Laboratory,
National Advisory Committee for Aeronautics,
Langley Field, Va.

REFERENCES

1. Lawrence, H. R., and Gerber, E. H.: The Aerodynamic Forces on Low Aspect Ratio Wings Oscillating in an Incompressible Flow. Jour. Aero. Sci., vol. 19, no. 11, Nov. 1952, pp. 769-781. (Errata issued, vol. 20, no. 4, Apr. 1953, p. 296.)
2. Runyan, Harry L., Woolston, Donald S., and Rainey, A. Gerald: A Theoretical and Experimental Study of Wind-Tunnel-Wall Effects on Oscillating Air Forces for Two-Dimensional Subsonic Compressible Flow. NACA RM L52I17a, 1953.
3. Theodorsen, Theodore: General Theory of Aerodynamic Instability and the Mechanism of Flutter. NACA Rep. 496, 1935.
4. Nelson, Herbert C., and Berman, Julian H.: Calculations on the Forces and Moments for an Oscillating Wing-Aileron Combination in Two-Dimensional Potential Flow at Sonic Speed. NACA TN 2590, 1952.
5. Garrick, I. E., and Rubinow, S. I.: Flutter and Oscillating Air-Force Calculations for an Airfoil in a Two-Dimensional Supersonic Flow. NACA Rep. 846, 1946. (Supersedes NACA TN 1158.)
6. Minhinnick, I. T.: Subsonic Aerodynamic Flutter Derivatives for Wings and Control Surfaces (Compressible and Incompressible Flow). Rep. No. Structures 87, British R.A.E., July 1950.
7. Watkins, Charles E.: Effect of Aspect Ratio on the Air Forces and Moments of Harmonically Oscillating Thin Rectangular Wings in Supersonic Potential Flow. NACA Rep. 1028, 1951.
8. Statler, I. C., and Easterbrook, M.: Handbook for Computing Non-Stationary Flow Effects on Subsonic Dynamic Longitudinal Response Characteristics of an Airplane. Rep. No. TB-495-F-12, Cornell Aero. Lab., Inc., Mar. 1, 1950.

AERODYNAMIC FORCES INDICATING TUNNEL-WALL EFFECTS ON A=2 WING

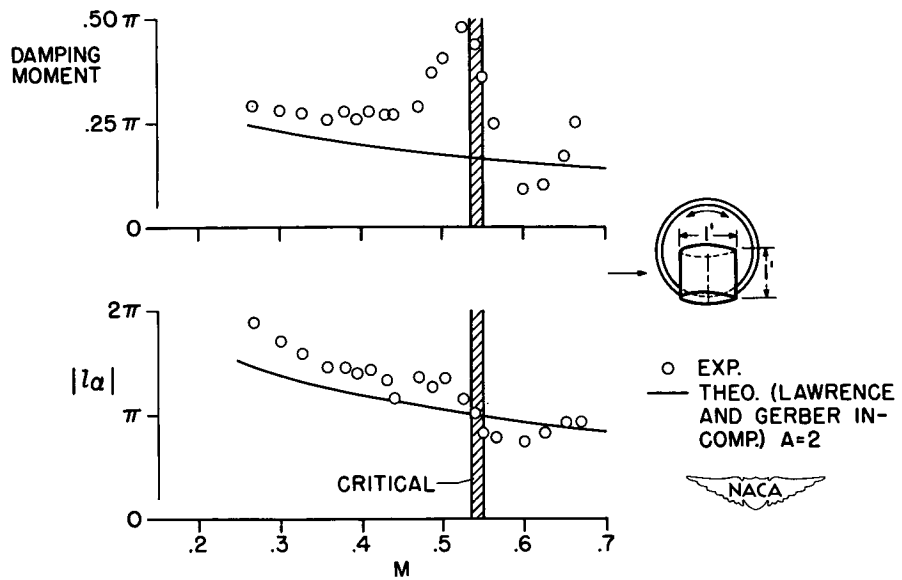

Figure 1.

AERODYNAMIC COEFFICIENTS FOR A=2 RECTANGULAR WING

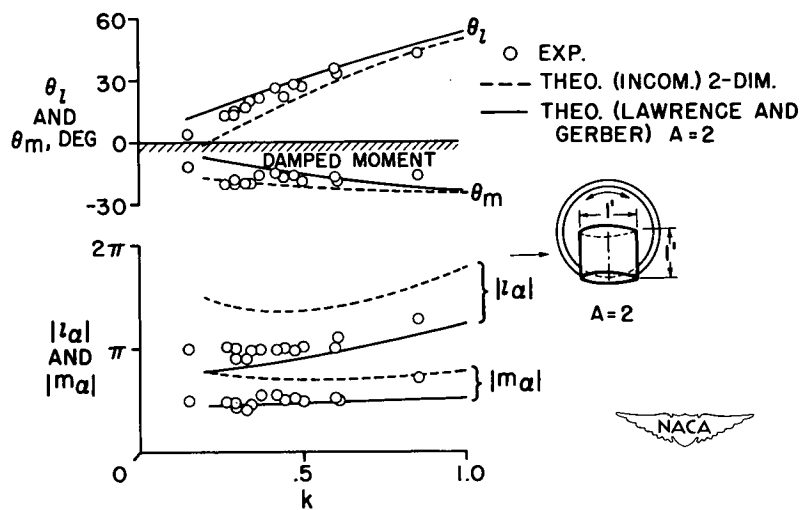

Figure 2.

AERODYNAMIC COEFFICIENTS FOR A=2, 63.4° DELTA WING

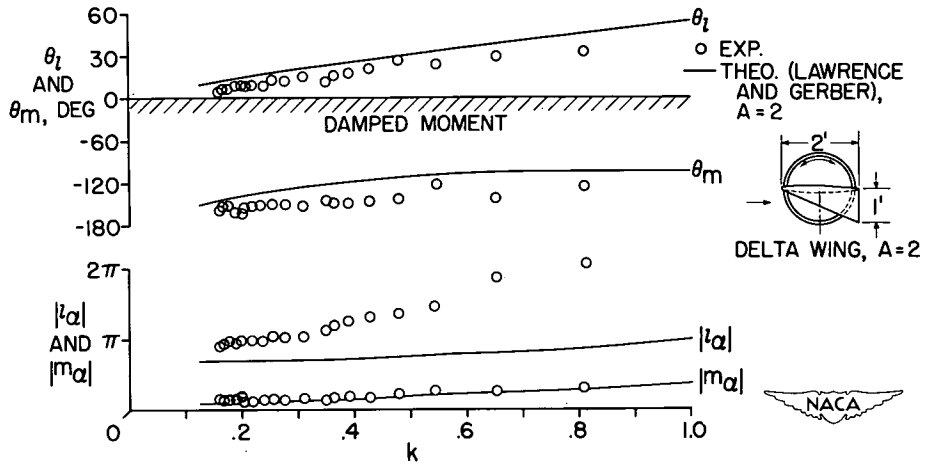

Figure 3.

AERODYNAMIC COEFFICIENTS FOR A WING-TANK COMBINATION

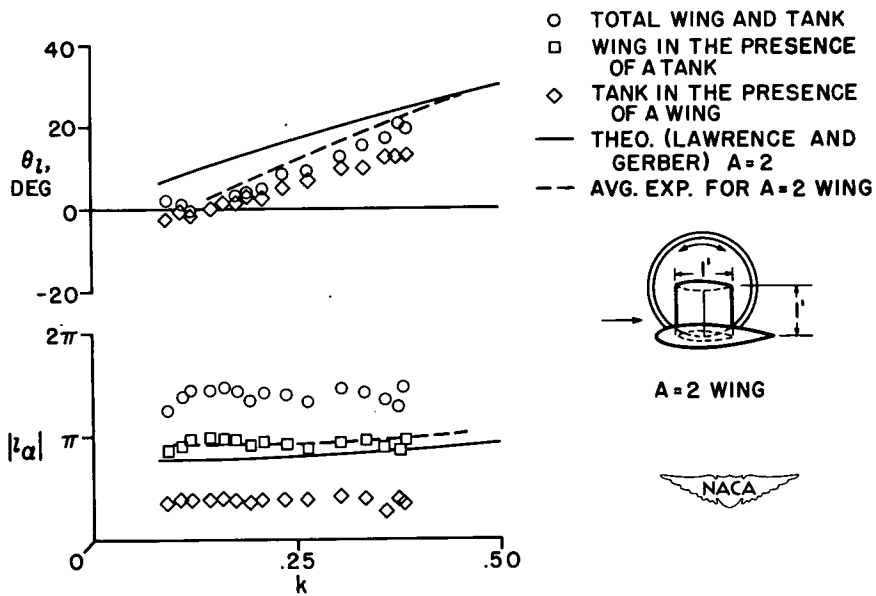

Figure 4.

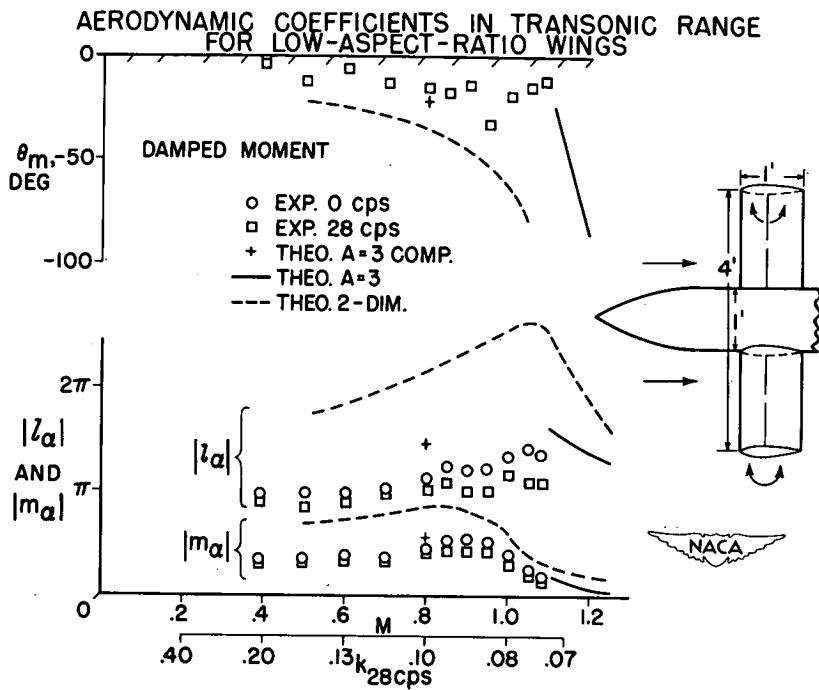

Figure 5.