

CONFIDENTIAL

Copy
RM E53B02

NACA RM E53B02

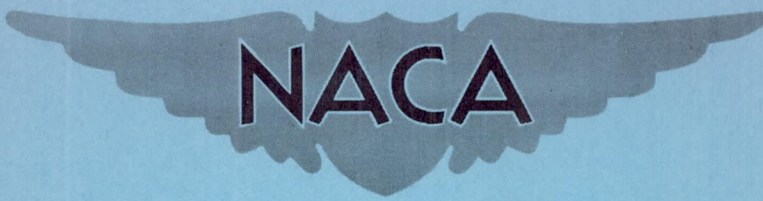

RESEARCH MEMORANDUM

ALTITUDE STARTING CHARACTERISTICS OF AN AFTERBURNER
WITH AUTOIGNITION AND HOT-STREAK IGNITION

By P. E. Renas, R. W. Harvey, Sr., and E. T. Jansen

Lewis Flight Propulsion Laboratory
Cleveland, Ohio

CLASSIFIED DOCUMENT

This material contains information affecting the National Defense of the United States within the meaning of the espionage laws, Title 18, U.S.C., Secs. 793 and 794, the transmission or revelation of which in any manner to an unauthorized person is prohibited by law.

NATIONAL ADVISORY COMMITTEE
FOR AERONAUTICS

WASHINGTON

April 6, 1953

CLASSIFICATION CHANGED TO UNCLASSIFIED
AUTHORITY: NACA RESEARCH ABSTRACT NO. 125
EFFECTIVE DATE: FEBRUARY 26, 1958
WHL

CONFIDENTIAL

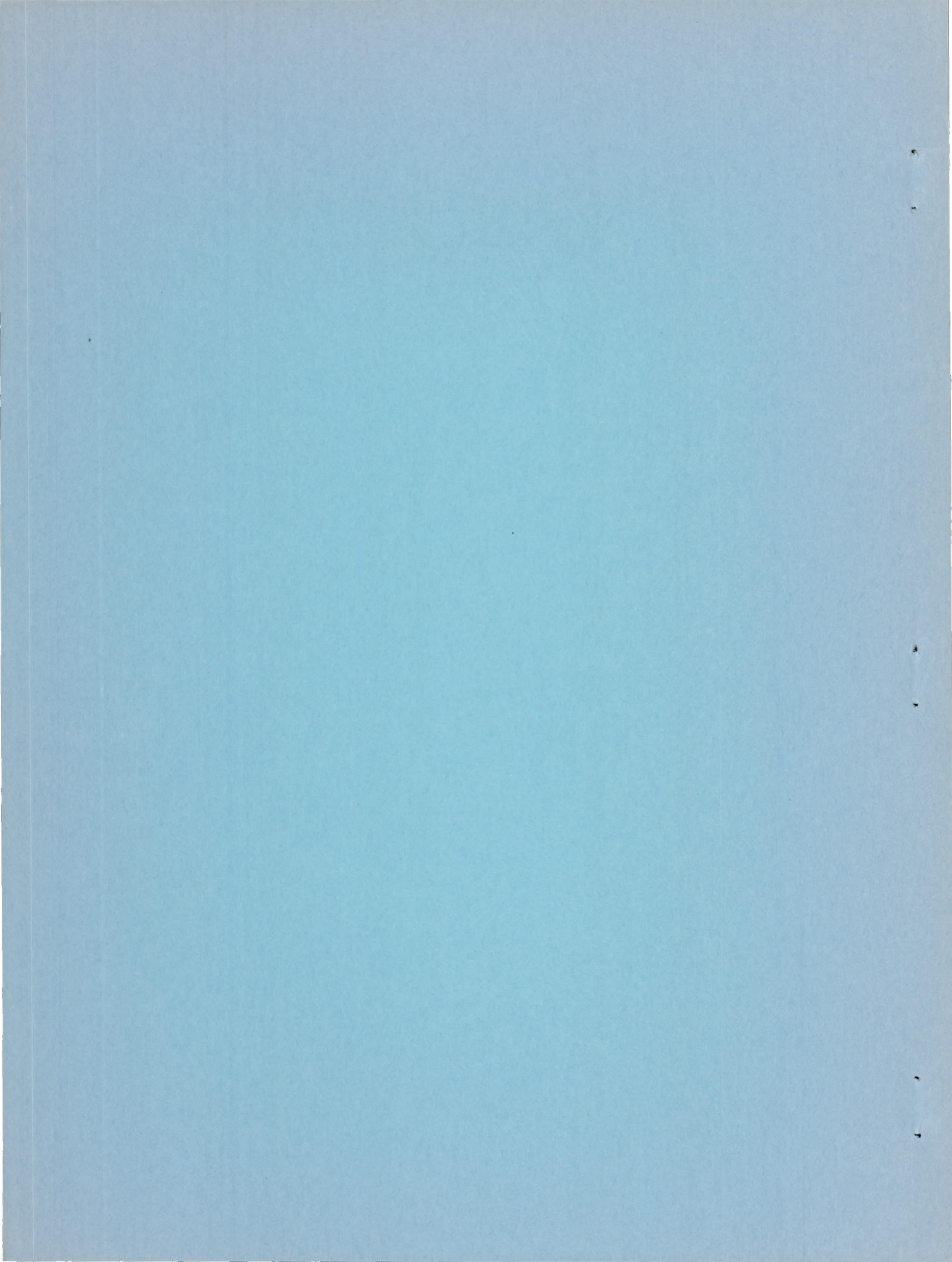

NATIONAL ADVISORY COMMITTEE FOR AERONAUTICS

RESEARCH MEMORANDUMALTITUDE STARTING CHARACTERISTICS OF AN AFTERBURNER WITH
AUTOIGNITION AND HOT-STREAK IGNITION

By P. E. Renas, R. W. Harvey, Sr.* , and E. T. Jansen

SUMMARY

An investigation was conducted in an altitude test chamber at the NACA Lewis laboratory to determine the altitude starting characteristics of an afterburner with autoignition and with hot-streak ignition. Transient afterburner ignition data were obtained over a range of altitudes from 30,000 to 50,000 feet at a flight Mach number of 0.60.

Afterburner ignition with a torch igniter located axially at approximately the midpoint of the combustion chamber was possible over the entire altitude range, but ignition with a torch igniter located in the transition section $1\frac{5}{8}$ inches upstream of the turbine stators proved unsatisfactory at an altitude of 50,000 feet due to the inability to obtain flame through the turbine. Increasing the afterburner-inlet total pressure at a constant afterburner fuel-air ratio decreased the afterburner ignition time. Hot-streak ignition was possible within 2 seconds after the time required to obtain the preset, normal afterburner fuel pressure, whereas autoignition required from 4 to 7 seconds for the range of altitudes investigated. Following ignition there was a period of oscillatory operation existing in the engine-afterburner before steady-state stable operation was attained. The time required to obtain steady-state operation decreased as afterburner-inlet total pressure increased. The duration of oscillations also decreased with hot-streak ignition because the fuel-air mixture was ignited before a large volume of combustible mixture was accumulated in the afterburner.

INTRODUCTION

Ignition of the fuel-air mixture in an afterburner of a turbojet engine at altitude has often proved to be a difficult problem to solve. Electrical ignition has not proven satisfactory because of the unreliability of such systems (ref. 1). For example, the use of a spark ignition system requires that some of the components be mounted in the

*Mr. Harvey, of ARO Inc., is on assignment to the NACA Lewis laboratory.

high-temperature regions associated with afterburner operation. In addition to the need for reliability of the ignition system, it is essential that the pilot of a combat airplane be able to obtain afterburner ignition almost instantaneously upon demand.

In an effort to improve afterburner starting characteristics and to decrease the time required for ignition, the investigation reported herein was conducted in an NACA Lewis altitude chamber on an axial-flow turbojet engine with an afterburner. Each afterburner start was considered to be composed of two time intervals. The first was the interval from the time the throttle was advanced until ignition occurred, and the second was the time interval between ignition and the attainment of stable operation. The altitude starting characteristics of the afterburner were determined and transient fuel flow and pressure data were obtained for both the engine and afterburner. The ignition characteristics were investigated with autoignition and with each of two hot-streak-ignition systems over a range of altitudes from 30,000 to 50,000 feet at a flight Mach number of 0.60.

2787

The ignition data reported herein were obtained for two afterburner configurations. Autoignition data are included for both configurations and hot-streak-ignition data, for only one. The principle differences between the two configurations was an alteration of the radial afterburner-fuel distribution and the addition of turbine-outlet straightening vanes.

APPARATUS

Engine-Afterburner

The turbojet engine and afterburner used in this investigation are shown schematically in figure 1. The engine has a 12-stage axial-flow compressor, 8 tubular combustion chambers, and a single-stage turbine. The primary components of the afterburner are a diffuser, a fuel-injection system, a 2-ring V-type flameholder, a combustion chamber, and a clamshell-type variable-area exhaust nozzle. The diffuser is approximately 39 inches long with a 13.5-inch diameter depressed flame seat in the downstream end of the diffuser inner cone. The flameholder is mounted at a position 5 inches downstream of the diffuser. The distance from the flameholder to the nozzle outlet, about 68 inches, includes the burning section and the variable-area exhaust nozzle.

The basic afterburner configuration was used for obtaining the starting data reported herein, but the fuel-distribution system was modified and straightening vanes were added at the turbine outlet during

the investigation. These changes were made in an attempt to improve the performance and operational characteristics of the afterburner.

The fuel system for configuration 1 consisted of 19 fuel-spray bars circumferentially located as shown in figure 2(a). The unequal circumferential spacing of the fuel-spray bars was imposed by the support struts for the inner cone and the fuel line to the internal fuel manifold which were located in the same axial plane. The 20 fuel spray bars used in configuration 2 (fig. 2(b)) were located at equal circumferential spacings 4 inches downstream of the original bars. In addition, configuration 2 had turbine-outlet straightening vanes.

Electronic Control

The primary purpose of the electronic control system is to maintain optimum engine operation for any setting of the thrust selector. Optimum operating conditions scheduled into the control were determined from known performance, operational, and safety characteristics for any given operating condition during both afterburning and nonafterburning operation. The parameters that the electronic control senses are: engine speed, engine-inlet temperature, compressor-outlet static pressure, turbine-outlet temperature, and thrust-selector position. The parameters that the control regulates are: engine fuel flow, afterburner fuel flow, and exhaust-nozzle area. A block diagram of the control and engine is shown in figure 3.

The manner in which the control operates is as follows: A thrust-selector position defines a certain engine-afterburner condition. If the thrust selector position is between 0° and 92° , the afterburner is inoperative, and if the selector position is between 92° and 110° , the afterburner is operating at various thrust levels. As the thrust selector is advanced through the nonafterburning region, the fuel-flow and the nozzle-position schedules of the control are set to allow rapid acceleration of the engine at low turbine-outlet temperature up to rated engine speed. The exhaust nozzle then closes to bring the turbine-outlet temperature up to the rated value, while an overspeed governor maintains rated engine speed. Advancing the thrust selector into the afterburning region opens the afterburner fuel valve, permitting fuel to enter the afterburner. Following ignition of the afterburner fuel-air mixture, the control starts to open the exhaust nozzle to the required area so as to maintain turbine-outlet temperature at the rated value.

Installation

The altitude test chamber in which the engine was installed is 10 feet in diameter and 60 feet in length. The test chamber is divided into three sections separated by bulkheads: the air-inlet section, the engine compartment, and the exhaust section (fig. 1). The front bulkhead, which incorporated a labyrinth seal around the forward section of the engine, allowed freedom of movement of the engine in an axial direction. The rear bulkhead was installed to act as a radiation shield and to prevent recirculation of the hot exhaust gases about the engine. The engine was mounted on a test bed which allowed the measurement of steady-state thrust.

Instrumentation

Steady-state instrumentation. - The locations of the instrumentation stations before and after each of the principle components of the engine are shown in figure 1. Fuel flow was measured by rotameters which were calibrated for the type fuel used in this investigation (MIL-F-5624A grade JP-4).

Transient instrumentation. - Transient measurements of engine speed, nozzle position, engine fuel-valve position, afterburner fuel-valve position, and compressor-outlet static pressure were transferred directly from the electronic control to the recording instrument. Transient instrumentation was installed to measure turbine-outlet temperature, afterburner skin temperature, thrust-selector position, a local gas temperature in the burning region, and increases in afterburner fuel-manifold pressure, afterburner fuel flow, and torch-igniter fuel pressure. The local gas temperature was used to obtain an indication of burner ignition and the relative rise in temperature near the afterburner shell for the various operating conditions.

The film recording instrument was an 18-channel oscillograph. The engine-afterburner parameters and the means of measurement for both transient and steady-state operation are listed in table I.

Torch Igniters

The installation of the torch igniters used in this investigation and the associated instrumentation and controls are shown in figure 4. With torch igniter A (fig. 5(a)), fuel was injected into an engine combustion chamber in sufficient quantity to approximately double the fuel-air ratio in that chamber. Fuel flow to the igniter was regulated by a needle valve placed in the fuel supply line in order to obtain the

desired flow. With torch igniter B (fig. 5(b)), a fuel-air mixture was injected into the transition section $1\frac{5}{8}$ inches upstream of the leading edge of the turbine stators. The fuel was mixed in the injector with air taken in between the transition liner and the casing assembly. Fuel flow to torch igniter B was regulated by a metering orifice in the base of the igniter. A 0.046-inch-diameter orifice approximated the flow obtained with torch igniter A.

PROCEDURE

The engine-inlet total temperature and total pressure and the exhaust static pressure were set to simulate the desired altitude and flight Mach number condition before each attempt to ignite the afterburner. At this simulated flight condition, a set of steady-state nonafterburning performance data was taken on both the transient recorder and the steady-state instrumentation with the engine operating at rated speed, 7950 rpm, and rated turbine-outlet temperature, 1300° F. Transient data were then recorded during a series of afterburner ignition attempts. During this investigation, the afterburner fuel schedule was removed from the electronic control and by use of a potentiometer any desired fuel flow could be preset for the 110° thrust-selector position.

A hot-streak ignition run consisted in scheduling the afterburner fuel flow, manually advancing the thrust selector from 92° to 110°, turning on fuel to the torch igniter for approximately 1 second after a predetermined time delay, and allowing a steady-state operating condition to be reached. The minimum ignition time was determined by progressively decreasing the time delay between advancing the thrust selector and operating the torch igniter. The minimum was taken as the point at which ignition would be impossible if the time delay in supplying fuel to the torch igniter was decreased an additional 0.5 second. At least three afterburner ignitions were made with corresponding time delays in order to establish the minimum ignition time. Knowing this time made it possible to obtain representative starting data with a minimum number of transient recordings.

The procedure followed in making an autoignition attempt was merely the advancement of the throttle after prescheduling the desired afterburner fuel flow and allowing a steady-state operating condition to be reached following the spontaneous ignition of the fuel-air mixture. Autoignition data were obtained on afterburner configurations 1 and 2, but hot-streak ignition data were obtained only on configuration 2.

After the transient data were recorded, a set of steady-state afterburning-performance data was obtained on both the transient recorder and the steady-state instrumentation. The steady-state data were taken so as to provide a means of determining the variation in magnitude of the various quantities recorded by the oscillograph film traces.

RESULTS AND DISCUSSION

Time-history traces were obtained for 13 engine and afterburner parameters during afterburner ignition attempts at altitudes of 30,000, 40,000, and 50,000 feet at a flight Mach number of 0.6. Examples of these film traces that illustrate autoignitions at altitudes of 30,000 and 50,000 feet are presented in figure 6. For the part of the investigation during which autoignition was studied, traces 10 through 13 were not in use.

Inspection of the film traces shows the existence of a time interval between advancing the throttle and obtaining ignition and a period of oscillatory operation of the engine-afterburner following ignition. The oscillations following ignition are caused by the interaction of the multiloop control in conjunction with the engine behavior. The sequence of events occurring in the engine-afterburner and the electronic control during ignition and stabilization of burning is as follows: The fuel-air mixture in the afterburner ignites while the exhaust nozzle is in a closed or nonafterburning-operation position. Because the exhaust nozzle is closed, the back pressure in the tail pipe increases, raising the pressure level through the engine and tending to decrease the engine speed. The control, sensing the increase in compressor-outlet static pressure and the decrease in engine speed, starts to increase the engine fuel flow. This increase in engine fuel flow, along with the increase in pressure level at the turbine outlet and the decrease in speed, tends to drive the turbine-outlet temperature over the limiting value. The over-temperature condition feeds an error signal into the control causing the exhaust nozzle to open. Because the temperature-error signal is large, the nozzle starts to open very rapidly decreasing the pressure level in the afterburner. This decrease in afterburner pressure level in turn decreases the compressor-outlet static pressure which causes the control to cut-back the engine fuel flow. Both the increase in nozzle area and the decrease in engine fuel flow cause the turbine-outlet temperature to decrease rapidly and thus reduce the temperature-error signal to the control. The signal reduction causes the control to stop opening the nozzle and, in some cases, to actually start closing the nozzle before the required area is obtained; the turbine-outlet temperature is driven over the limit and the cycle is again repeated but with diminishing magnitude.

The cycling is continued until the desired nozzle area is reached and the length of time of this oscillation is dependent upon the pressure level at which the engine-afterburner is operating. The magnitude of the oscillation, as well as the time for each cycle, increases as the pressure level in the afterburner is decreased.

Afterburner Ignition Characteristics

Time required for ignition. - Autoignition data were obtained on afterburner configurations 1 and 2; hot-streak ignition data were obtained only on configuration 2. Because the principal change between the two afterburner configurations consisted in altering the afterburner fuel-spray bars, the autoignition characteristics of configuration 2 were checked against those of configuration 1. At similar flight conditions and afterburner fuel flows, the afterburner ignition time and the time for stable operation were in good agreement for the two configurations.

It was logical to assume that afterburner ignition would not be obtainable until sufficient fuel had been supplied to provide a combustible fuel-air mixture in the afterburner. The time required to attain this condition was dependent upon the time required for fuel to fill the fuel lines and the afterburner manifold. The afterburner fuel was supplied by a turbine pump operating on compressor-outlet bleed air. A measure of the time delay in obtaining fuel flow can be had by observing the time required for the afterburner fuel-manifold pressure to reach the normal value for the preset steady-state condition (fig. 7). As the afterburner fuel-air ratio (defined as the ratio of afterburner fuel to the unburned air entering the afterburner) increased or altitude decreased, the time required to reach normal afterburner fuel pressure decreased. For an afterburner fuel-air ratio of 0.04, above which the decrease in fuel pressure-rise time with increasing fuel-air ratio was less pronounced, the time required for afterburner fuel pressure to reach the preset value increased from about 2 seconds at 30,000 feet to about 6 seconds at 50,000 feet. The increase in afterburner fuel-pressure-rise time as fuel-air ratio decreased or altitude increased was due to less fuel being scheduled to the air-turbine pump to fill the volume of the afterburner fuel-manifold system. The acceleration rate of the air-turbine pump also decreased as altitude increased, because the mass flow of air through the pump decreased while the pump rotor inertia remained constant. Therefore, the increased time required for the pump to reach rated speed also contributed to the time required to fill the afterburner fuel-manifold system.

The effect of afterburner fuel-air ratio on afterburner ignition time is shown in figure 8, with ignition time being defined as the

elapsed time from the instant the thrust selector was advanced to the instant ignition of the fuel-air mixture in the burning section occurred. Data are presented for autoignition and hot-streak ignition with torch igniters A and B at altitudes of 30,000, 40,000, and 50,000 feet. The curves for time required to reach normal afterburner fuel pressure as shown in figure 7 are superimposed on figure 8. For both types of ignition, the afterburner ignition time decreased at all altitudes as fuel-air ratio was increased. Each afterburner ignition presented in figure 8 represents the minimum ignition time obtained during a series of ignition attempts at a preset afterburner fuel flow. The ignition characteristics with hot-streak ignition proved superior to those with autoignition at all altitudes. The minimum time for hot-streak ignition following the attainment of the preset fuel-pressure value varied from approximately 1 second at 30,000 feet to 2 seconds at 50,000 feet, whereas the minimum times for autoignition were 4 and 7 seconds at 30,000 and 50,000 feet, respectively, over the range of fuel-air ratios investigated. As was previously mentioned, the time required for afterburner fuel pressure to reach the preset value increased from about 2 to 6 seconds as the altitude was increased from 30,000 to 50,000 feet for a fuel-air ratio of 0.04. It is therefore obvious that the major portion of the time required to obtain ignition with a hot-streak system is consumed in filling the manifold with fuel.

At 30,000 feet, the minimum ignition time was attained for torch igniter B. Torch igniter B, because of its position, apparently produced a core of flame through the turbine; whereas torch igniter A allowed the flame more time to fan out and thus decreased its localized intensity. This decrease in flame intensity required an increase in the time to obtain an optimum localized fuel-air ratio for ignition. The ignition times for torch igniters A and B were approximately equal at 40,000 feet but only torch igniter A produced satisfactory hot-streak ignition at 50,000 feet. The failure to obtain ignition with torch igniter B at 50,000 feet was due to the inability to obtain flame through the turbine. Increasing the orifice size of torch igniter B to 0.0625 inch and then to 0.109 inch, which approximately tripled the fuel flow, did not improve the ignition properties obtained with the 0.046-inch-diameter orifice, and ignition was still impossible at an altitude of 50,000 feet. With orifice diameters of 0.018 or 0.0225 inch, afterburner ignition was impossible with igniter B at any altitude within the range investigated.

In an effort to improve afterburner ignition with torch igniter B at 50,000 feet, its location in the transition section was moved 3 inches upstream and subsequent data were obtained at altitudes of 40,000 and 50,000 feet. With this new location, flame was obtained through the turbine and the afterburner ignition times for torch igniter B corresponded to the ignition times obtained for torch

igniter A at both altitudes. It is therefore apparent that, with the original location of torch igniter B, the time the hot-streak fuel-air mixture was in contact with the flame of the engine combustion chamber at high altitude was not sufficient for ignition of the afterburner fuel-air mixture. Because the ignition times with torch igniter B moved upstream were only obtained by use of a timing instrument and not recorded on oscillograph film traces, the data are not presented in this report.

When only the pressure level was considered, reducing the afterburner-inlet total pressure at a constant afterburner fuel-air ratio increased the ignition time with both types of ignition investigated (fig. 9). The lines of constant afterburner fuel-air ratio were determined by cross-plotting the data presented in figure 8. This increase in ignition time becomes more evident below an afterburner-inlet total pressure of 1100 pounds per square foot absolute which corresponds to engine operation at rated conditions at an altitude of approximately 40,000 feet and a Mach number of 0.60.

Time required for stable operation. - The effect of afterburner-inlet total pressure on the time required for stable operation following ignition is shown in figure 10. Data are presented in this figure for an approximately constant afterburner fuel flow at each altitude; these fuel flows resulted in afterburner fuel-air ratios of 0.31, 0.30, and 0.40 at altitudes of 30,000, 40,000, and 50,000 feet, respectively. Increasing the afterburner-inlet total pressure or decreasing the altitude decreased the duration of oscillations in the engine-afterburner for both types of ignition investigated. The time for stable operation is defined as the elapsed time from ignition to the attainment of final steady-state operation.

The oscillations are a result of the interaction of the multiloop control in conjunction with the engine behavior. The period of oscillation depends on the time constant of the engine as well as the control-system constants. This time constant is a measure of the speed response of the engine to the disturbances in input variables and is equal to the inertia of the engine rotor divided by the change in torque for a given change in engine speed. Consequently, because the moment of inertia of the rotor is constant and the torque decreases with decreasing density, the time constant increases with altitude. Therefore, as the pressure level at which the afterburner is operating is reduced, the period of each oscillation, and thus the duration of the oscillations is increased.

The duration of oscillations was a minimum for hot-streak ignition at all afterburner pressure levels. As the afterburner-inlet total pressure increased from 650 to 1700 pounds per square foot absolute,

the time required for stable operation decreased from approximately 17 to 7 seconds for hot-streak ignition and from about 49 to 9 seconds for autoignition. This decrease in oscillation time with hot-streak ignition was due to ignition being attained before a large quantity of combustible mixture was accumulated in the afterburner and resulted in a more steady progression of flame.

Operational Characteristics

Dependable operation of the hot-streak fuel shut-off valve over the entire altitude and fuel pressure range is an essential requirement, because failure of this valve to close would mean a possible engine failure due to flame impinging on the turbine stator. The location of the igniter in the combustion zone must also be carefully chosen in order to obtain reliable afterburner ignition over the entire altitude range. In addition to the axial position of the igniter, the circumferential position should be so selected that flame does not impinge on a control thermocouple, and thus feed a false signal to the electronic control.

A failure of the fuel shut-off valve to close during a check run on torch igniter A resulted in several small cracks in the turbine stators directly downstream of the igniter. The cracks were not serious enough to warrant replacing the stators but the torch igniter was moved to an adjacent engine combustion chamber. Following this investigation, during which approximately 230 hot-streak ignitions were made, another inspection revealed no further deterioration of the engine-afterburner because of hot-streak ignition.

CONCLUDING REMARKS

For afterburner ignition attempts at altitudes of 30,000, 40,000, and 50,000 feet at a flight Mach number of 0.6, afterburner ignition time decreased as afterburner fuel-air ratio increased, and ignition with a torch igniter located axially at approximately the midpoint of the combustion chamber was possible over the entire altitude range. Ignition with a torch igniter located in the transition section $1\frac{5}{8}$ inches upstream of the turbine stators proved satisfactory at altitudes of 30,000 and 40,000 feet, but unsatisfactory at an altitude of 50,000 feet due to the inability to obtain flame through the turbine. This unsatisfactory condition was corrected by so locating the torch igniter in the combustion zone that the hot-streak fuel-air mixture had sufficient time in contact with the flame of the engine combustion chamber and was burning before it reached the turbine.

2787

Increasing the afterburner-inlet total pressure at a constant afterburner fuel-air ratio decreased the afterburner ignition time. The transient afterburner ignition data indicate that ignition was impossible until afterburner fuel-manifold pressure reached the approximate normal value for the preset steady-state condition. The time required for afterburner fuel pressure to reach the preset fuel pressure value decreased as the afterburner fuel-air ratio increased or altitude decreased. Hot-streak ignition was possible within about 2 seconds after the time required to attain the preset afterburner fuel pressure, whereas autoignition required from about 4 to 7 seconds following this increased fuel pressure for the range of altitudes investigated.

Following ignition there was a period of oscillatory operation existing in the engine-afterburner before steady-state operation was attained, and the time required for stable operation decreased as afterburner-inlet total pressure increased. Increasing the afterburner-inlet total pressure from 650 to 1700 pounds per square foot absolute decreased the time required to reach stable operation of the engine-afterburner following ignition from about 17 to 7 seconds for hot-streak ignition and from about 49 to 9 seconds for autoignition. The decrease in duration of oscillations with hot-streak ignition was due to the fuel-air mixture being ignited before a large volume of combustible mixture was accumulated in the afterburner.

Lewis Flight Propulsion Laboratory
National Advisory Committee for Aeronautics
Cleveland, Ohio

REFERENCE

1. Fleming, W. A., Conrad, E. William, and Young, A. W.: Experimental Investigation of Tail-Pipe-Burner Design Variables. NACA RM E50K22, 1951.

TABLE I. - INSTRUMENTATION



Trace	Measured quantity	Steady-state instrumentation	Transient instrumentation
1	Engine speed	Chronometric tachometer	Rectified voltage from tachometer; a-c generator
2	Turbine-outlet temperature	Average of 24 individual thermocouples connected to self-balancing potentiometer recorder	One chromel-alumel thermocouple located $\frac{1}{8}$ inches downstream of turbine
3	Exhaust-nozzle position	Voltmeter (0° to 50°) in nozzle actuator circuit	Potentiometer connected to nozzle actuator
4	Engine fuel-valve position	Voltmeter (0° to 50°) in engine fuel-valve-actuator circuit	Potentiometer connected to engine fuel valve
5	Afterburner fuel-valve position	Voltmeter (0° to 50°) in afterburner fuel valve actuator circuit	Potentiometer connected to afterburner fuel valve
6	Compressor-outlet static pressure	Vented pressure and one wall static tube	One wall static tube and pressure sensor potentiometer
7	Afterburner-skin temperature	Five individual skin thermocouples on self-balancing potentiometer recorder	Five individual rivet-type skin thermocouples connected in parallel
8	Thrust-selector position	Manual (0° to 110°)	Potentiometer connected to thrust selector
9	Exhaust-gas temperature	Three chromel-alumel thermocouples at station 7	Individual chromel-alumel thermocouple located at station 7
10	Afterburner fuel flow	Calibrated rotameter	Differential pressure pickup and transmitter
11	Afterburner fuel-manifold pressure		Pressure pickup and transmitter
12	Torch-igniter-A fuel pressure		Pressure pickup and transmitter
13	Torch-igniter-B fuel pressure		Pressure pickup and transmitter

2787

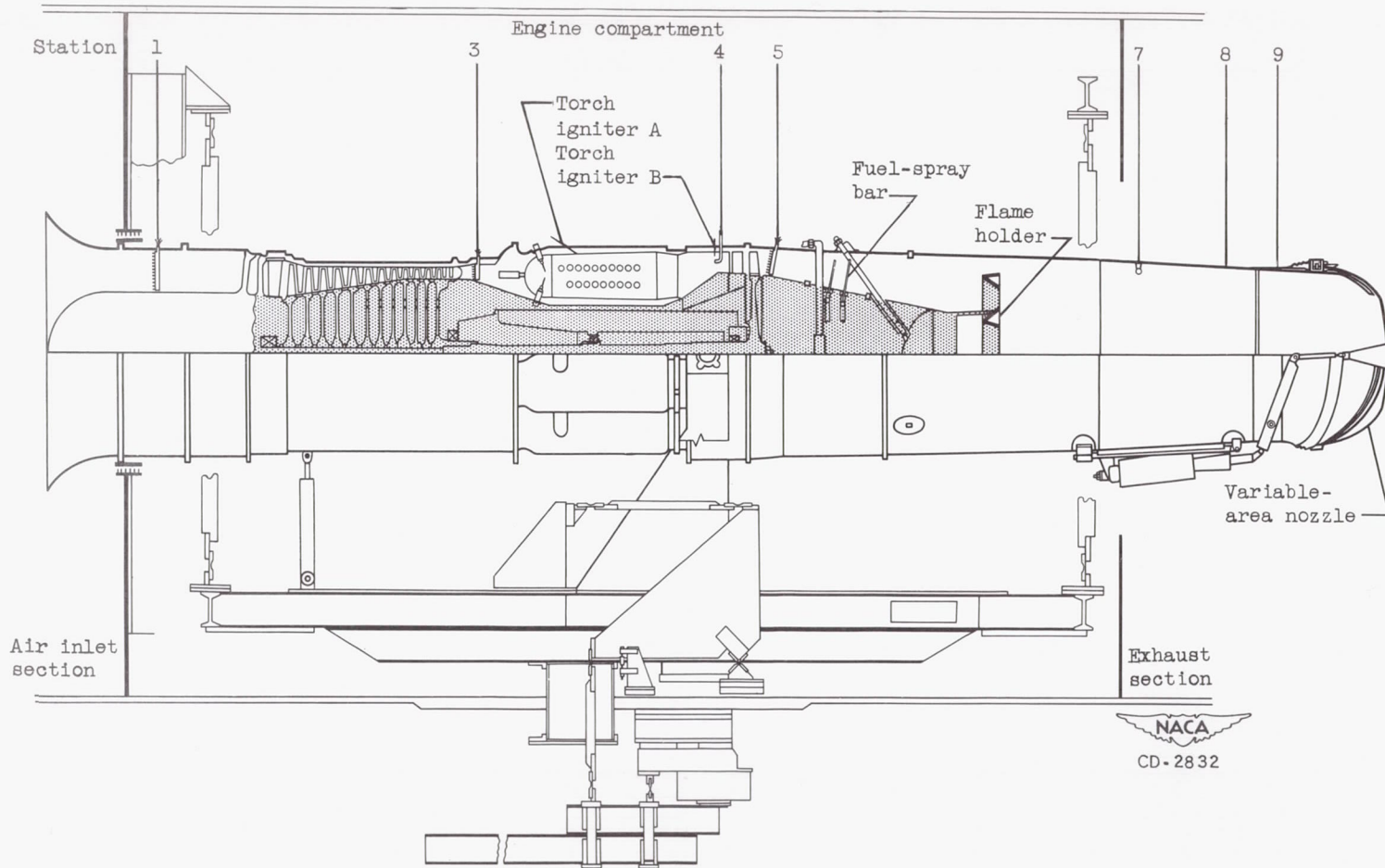

CONFIDENTIAL

Figure 1. - Engine installation showing location of instrumentation stations and torch igniters.

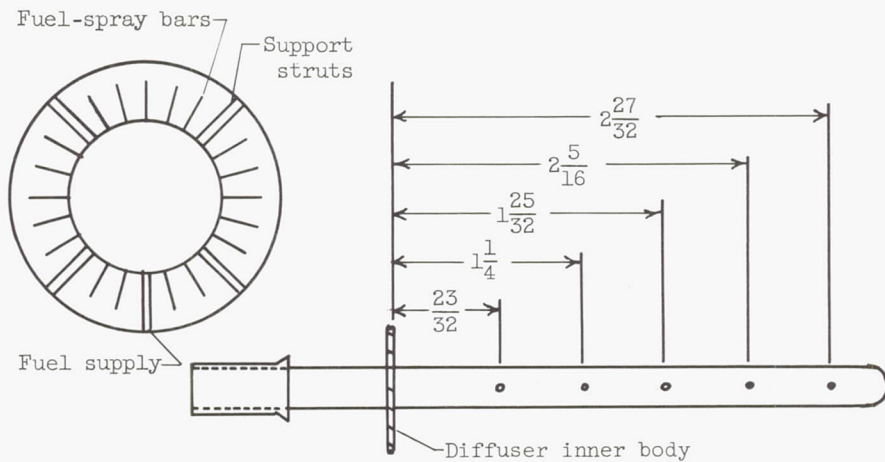

(a) Original fuel bars used in afterburner configuration 1. Annular passage height, $6\frac{7}{16}$ inches. All orifices 0.020 inch.

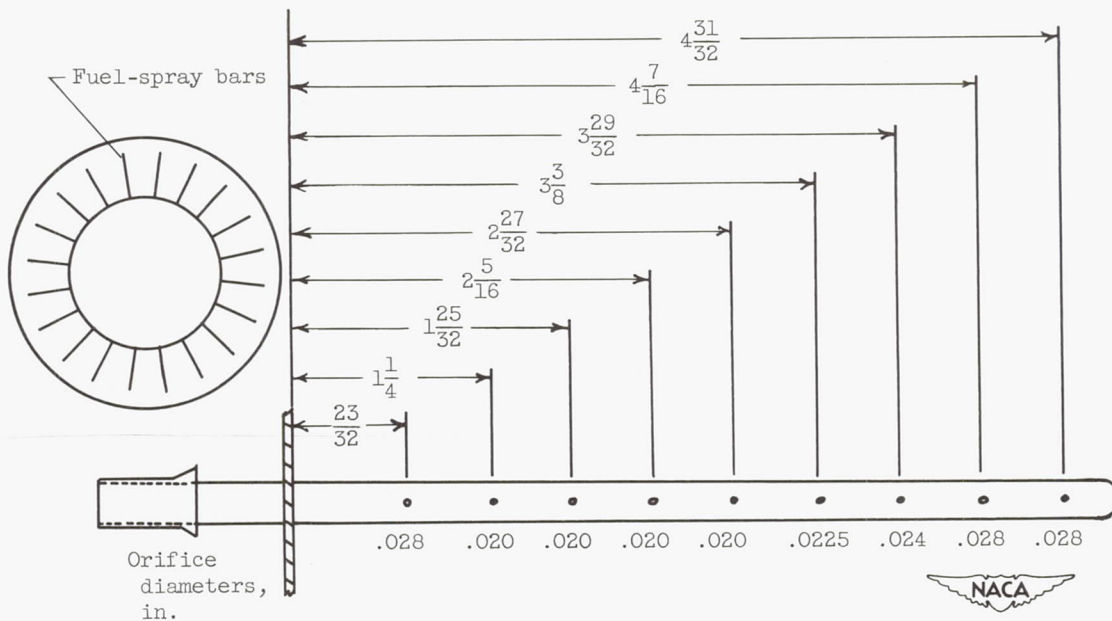

(b) Modified fuel bars used in afterburner configuration 2. Annular passage height, 7 inches.

Figure 2. - Sketches of afterburner fuel-spray bars for two afterburner fuel systems. (All dimensions in inches.)

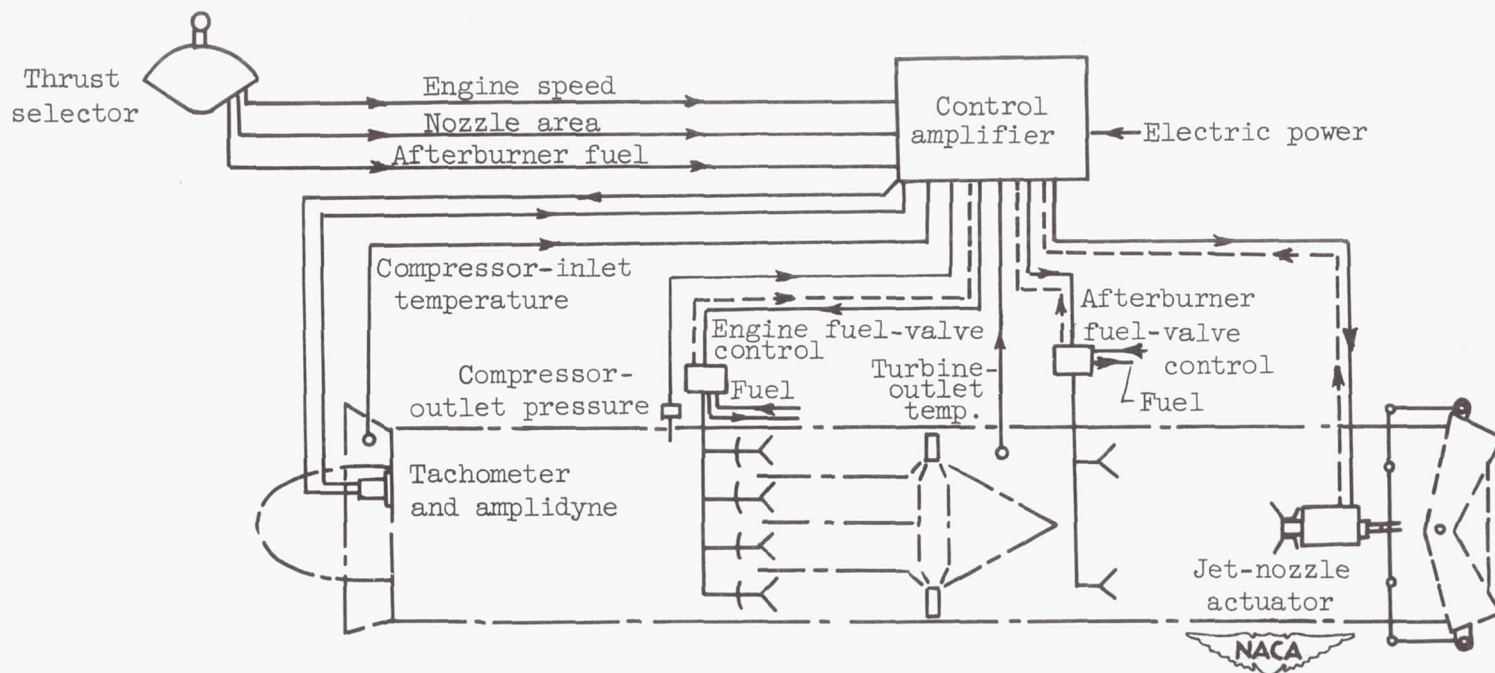

Figure 3. - Simplified block diagram of electronic integrating control.

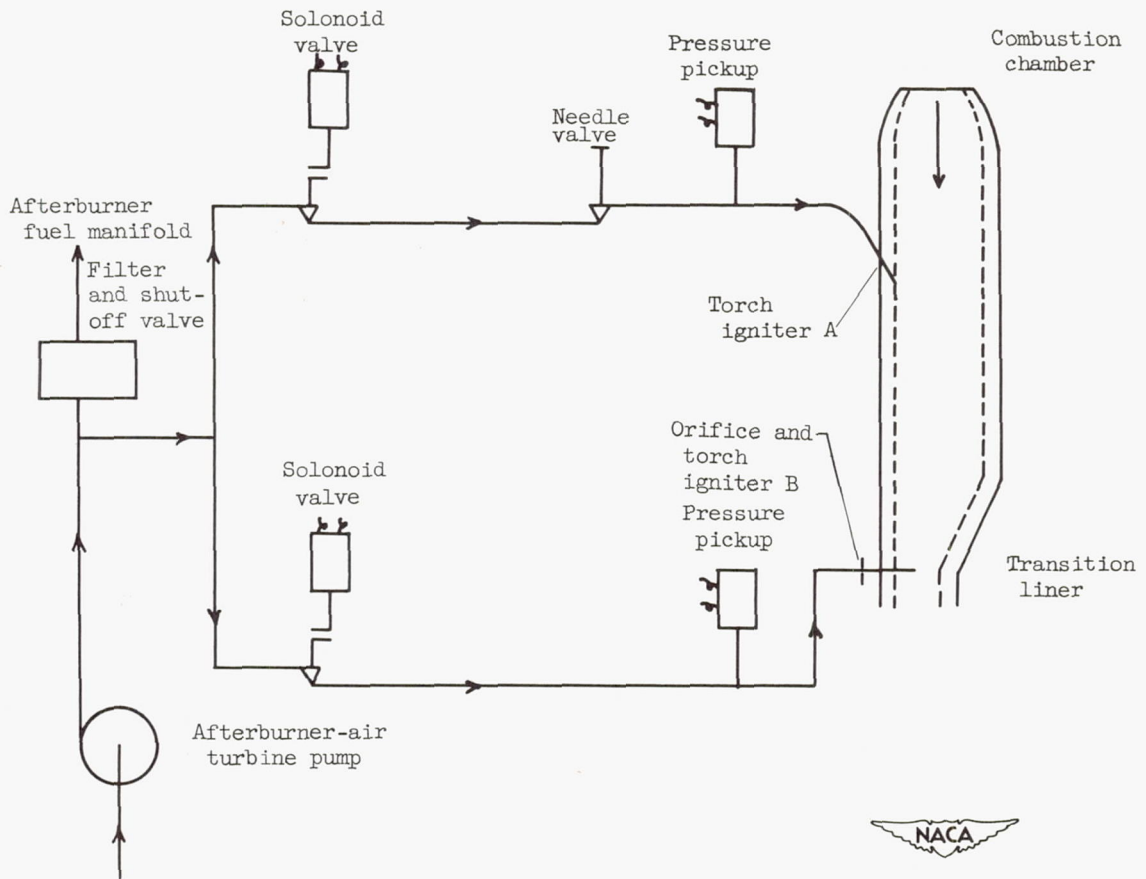
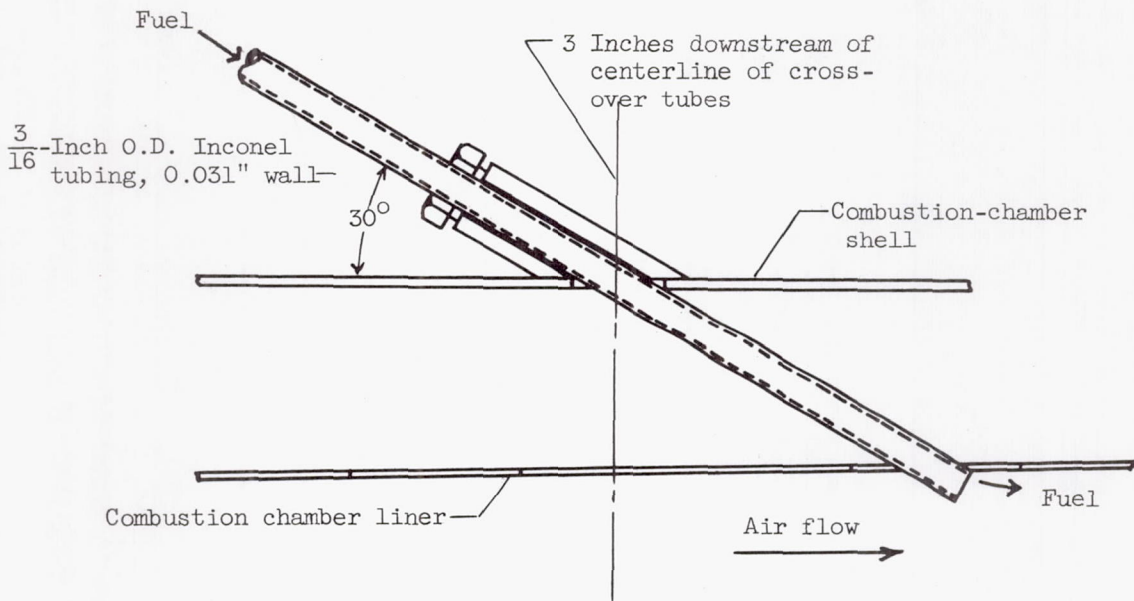
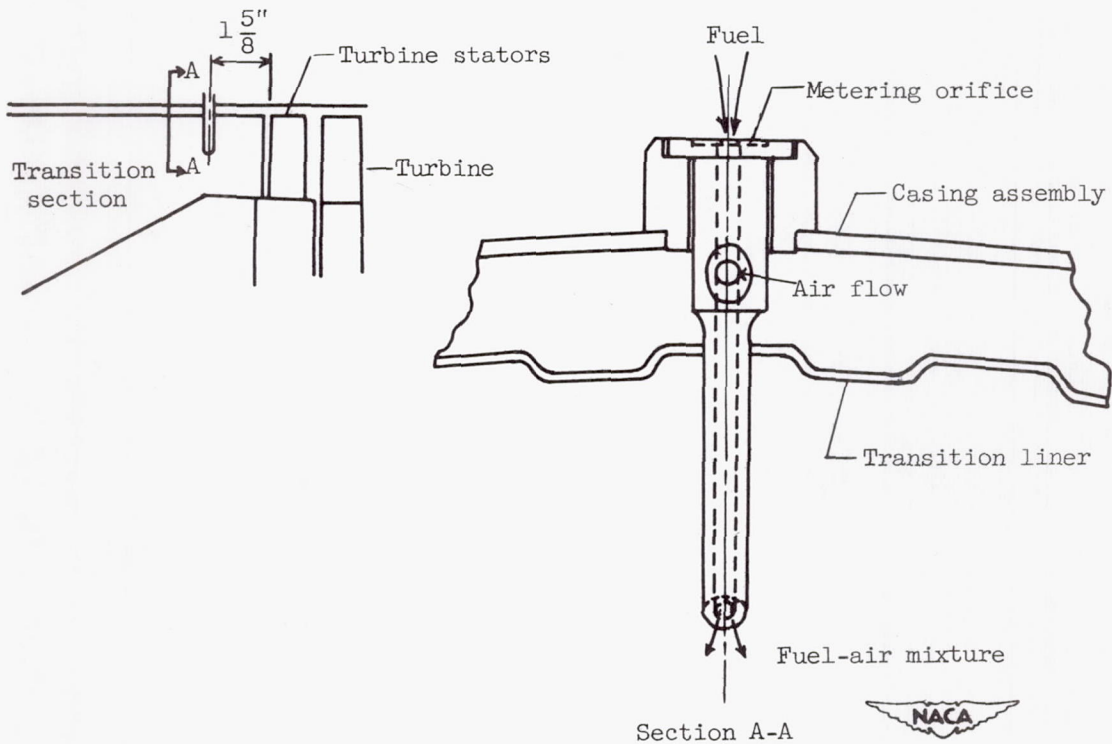

Figure 4. - Installation of torch igniters A and B, and associated instrumentation.

2787



(a) Torch igniter A.



(b) Torch igniter B.

Figure 5. - Details of torch igniters A and B.

2787

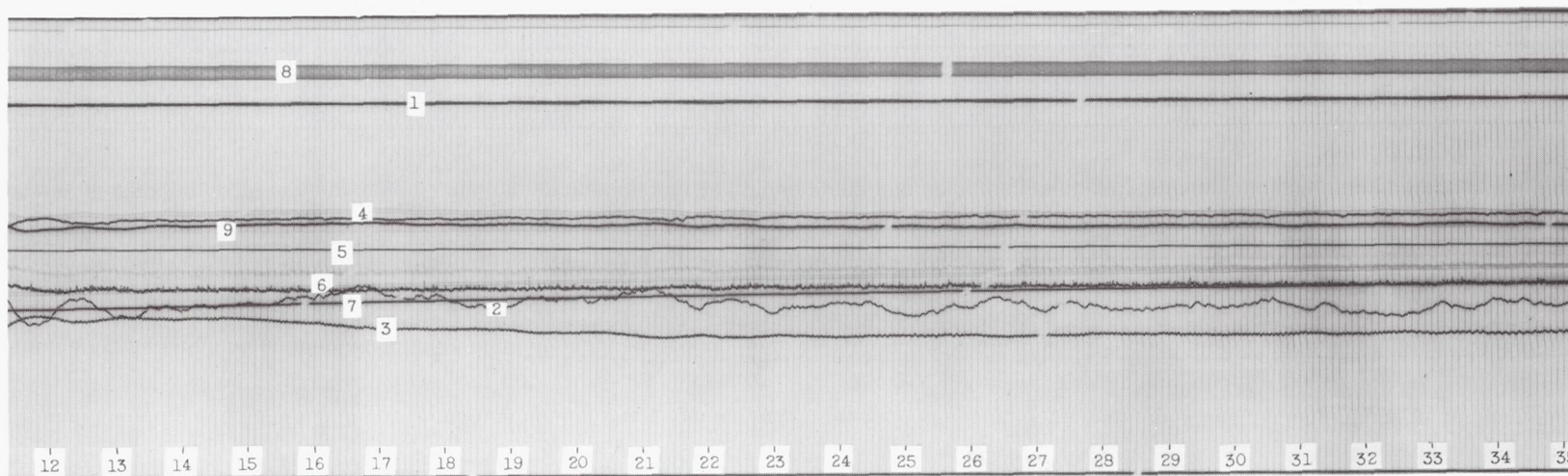
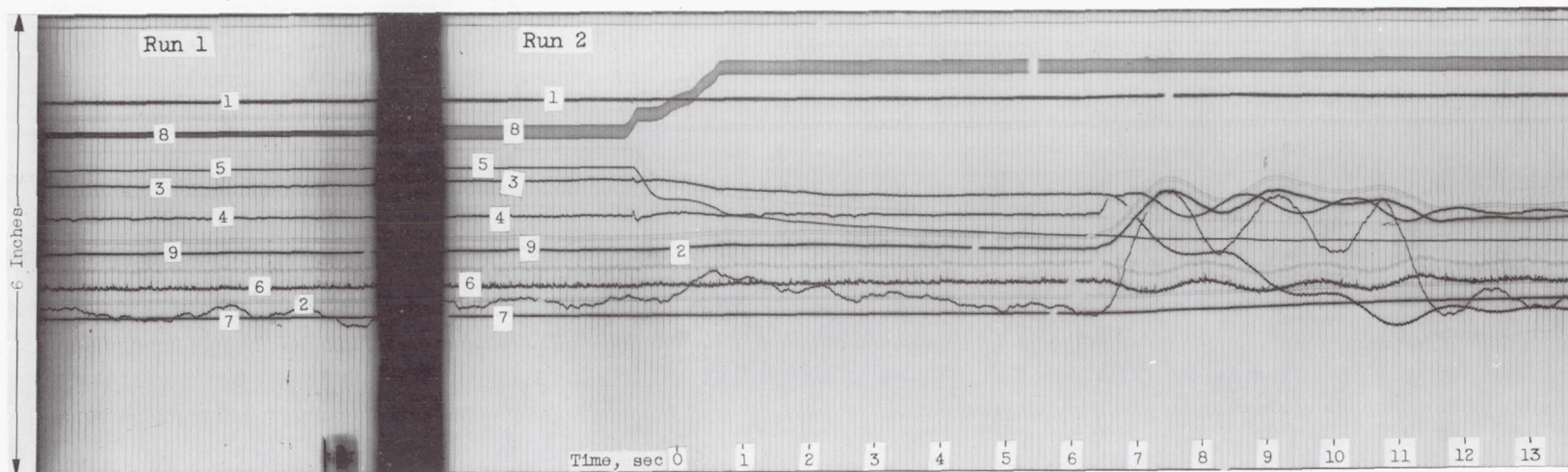

CONFIDENTIAL

CONFIDENTIAL

NACA RM E53B02

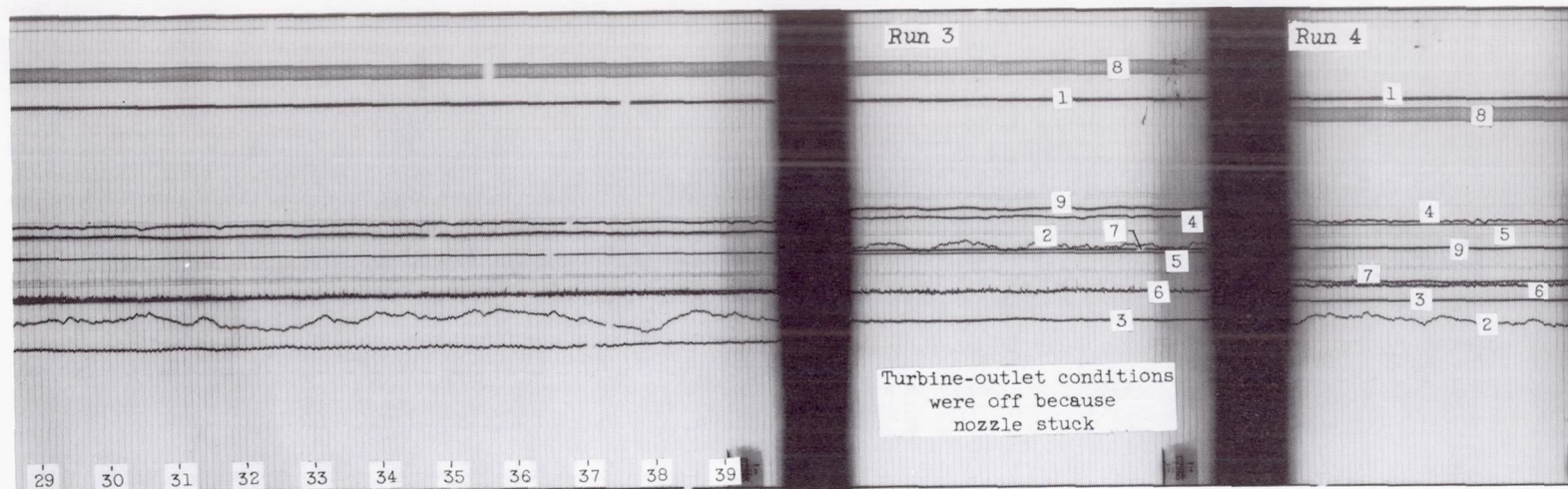

CONFIDENTIAL

CONFIDENTIAL

Run	Trace	Parameter
1	1	Engine speed
2	2	Turbine-outlet temperature
3	3	Exhaust-nozzle position
4	4	Engine fuel-valve position
	5	Afterburner fuel-valve position
	6	Compressor-outlet sensing pressure
	7	Exhaust-nozzle-inlet wall temperature
	8	Thrust-selector position
	9	Exhaust-gas temperature indication



(a) Altitude, 30,000 feet; flight Mach number, 0.6.

Figure 6. - Oscillograph film reproductions of steady-state and afterburner autoignition transient data. Engine speed, 7950 rpm.

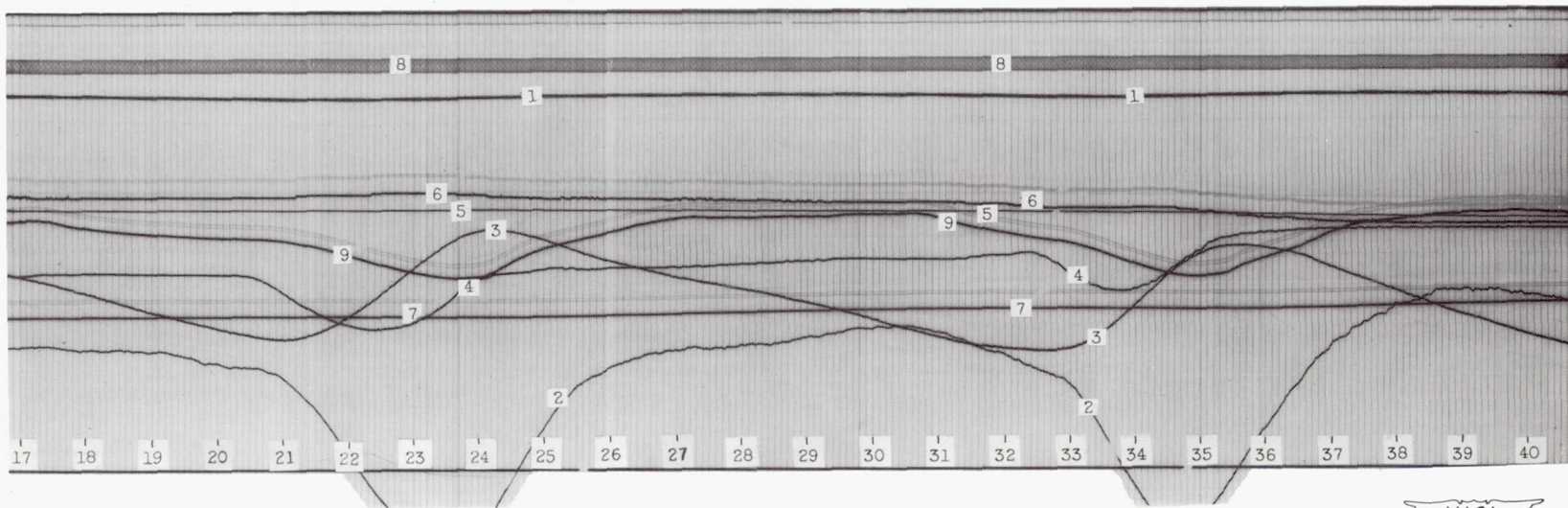
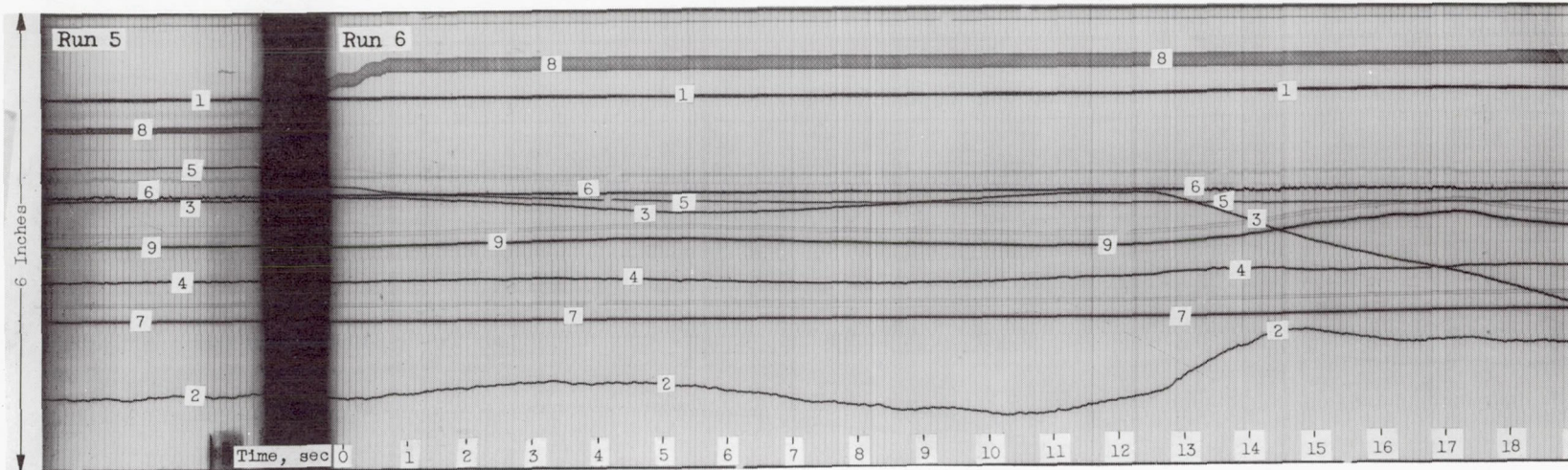

CONFIDENTIAL

CONFIDENTIAL

NACA RM E53E02

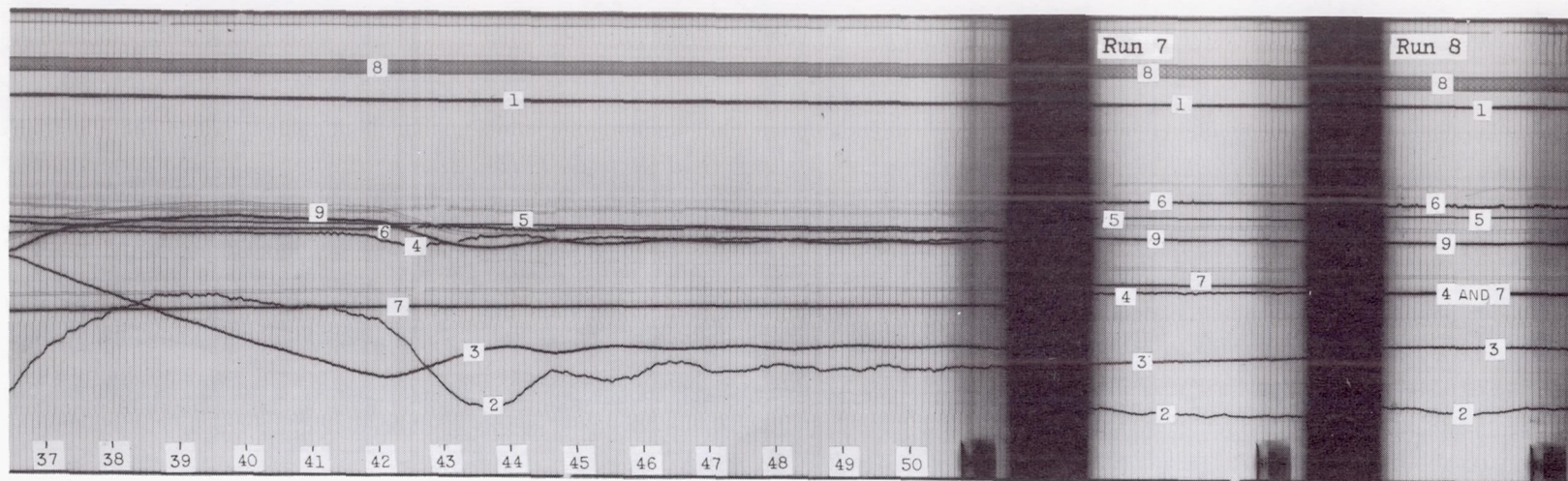

CONFIDENTIAL



Run	Parameter	Trace	Parameter
5	Steady-state nonafterburning	1	Engine speed
6	Autoignition	2	Turbine-outlet temperature
7	Steady-state afterburning	3	Exhaust-nozzle position
8	Steady-state afterburning	4	Engine fuel-valve position
		5	Afterburner fuel-valve position
		6	Compressor-outlet sensing pressure
		7	Exhaust-nozzle-inlet wall temperature
		8	Thrust-selector position
		9	Exhaust-gas temperature indication

(b) Altitude, 50,000 feet; flight Mach number, 0.6.

Figure 6. - Concluded. Oscillograph film reproductions of steady-state and afterburner autoignition transient data. Engine speed, 7950 rpm.

CONFIDENTIAL

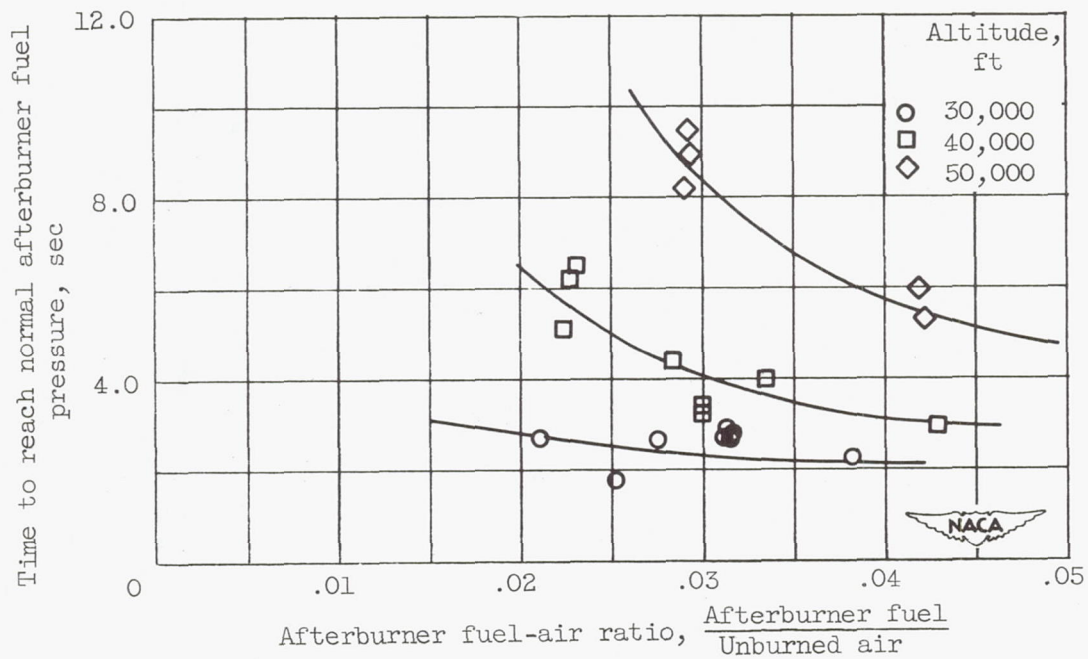

Figure 7. - Effect of afterburner fuel-air ratio setting on time required to reach normal afterburner fuel pressure. Flight Mach number, 0.60.

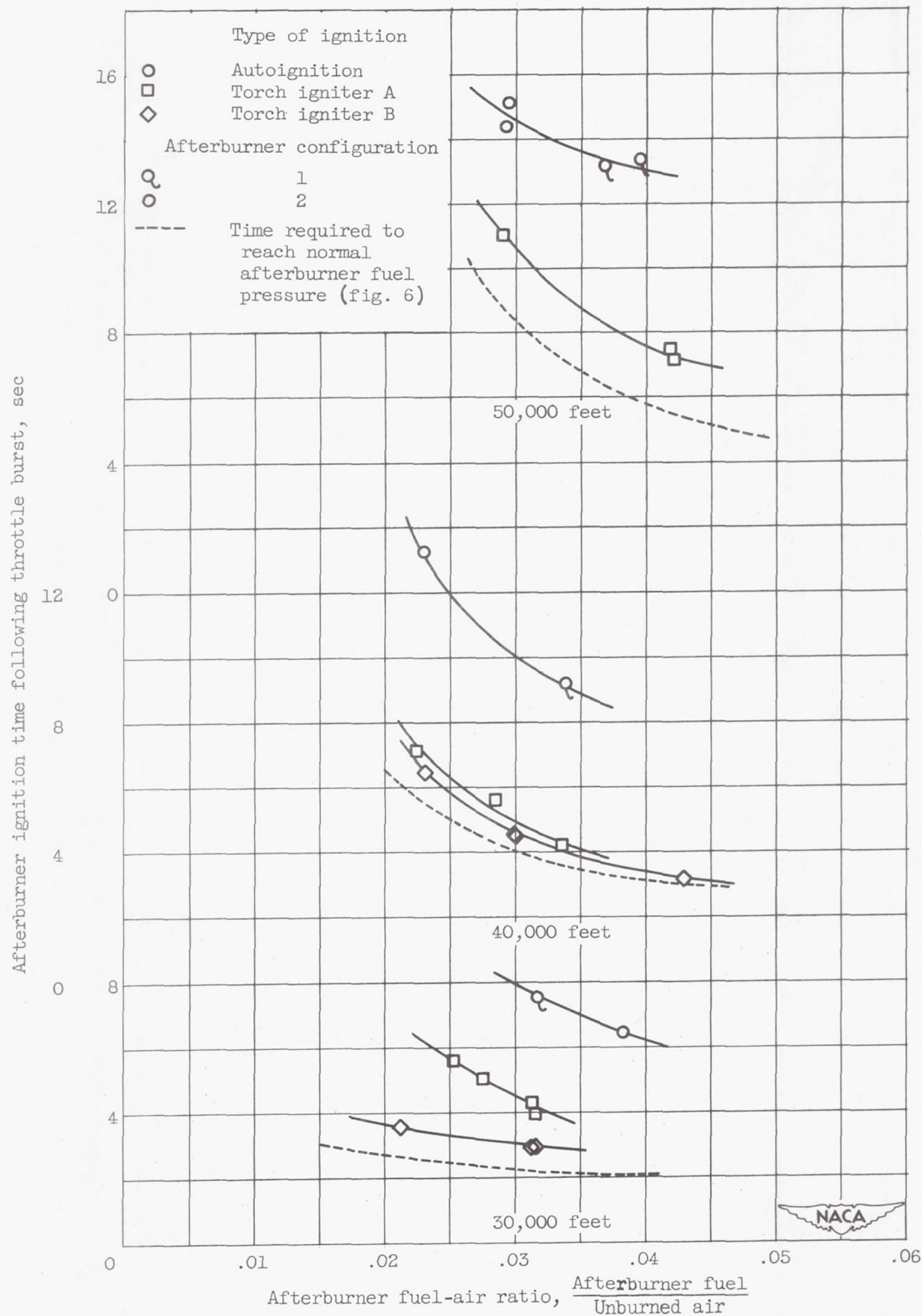
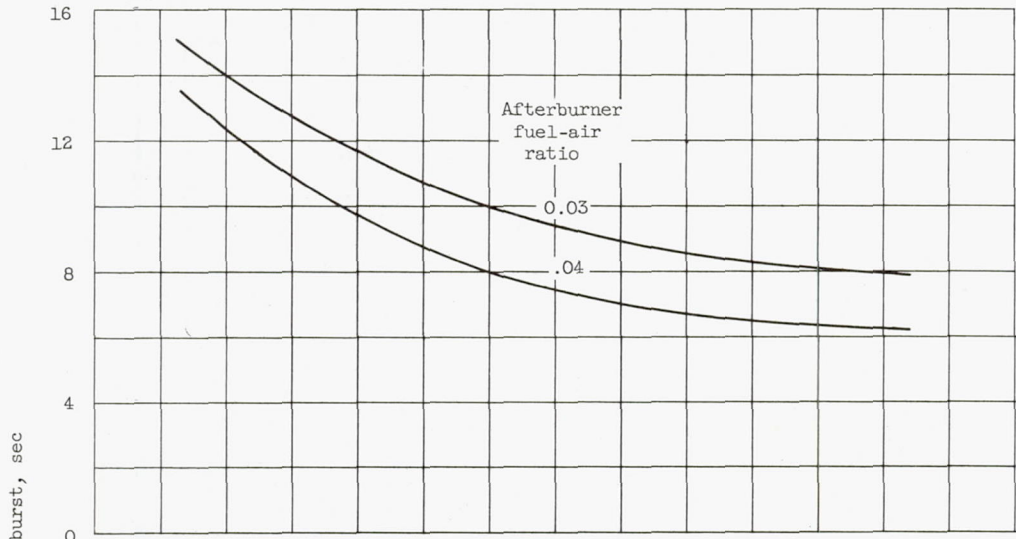
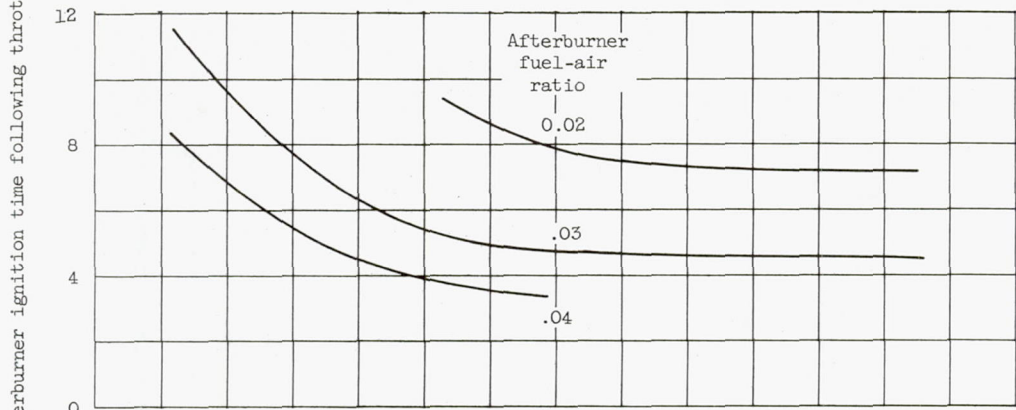

Figure 8. - Effect of afterburner fuel-air ratio and altitude on afterburner ignition time. Flight Mach number, 0.60.

2787



(a) Autoignition.



(b) Torch igniter A.

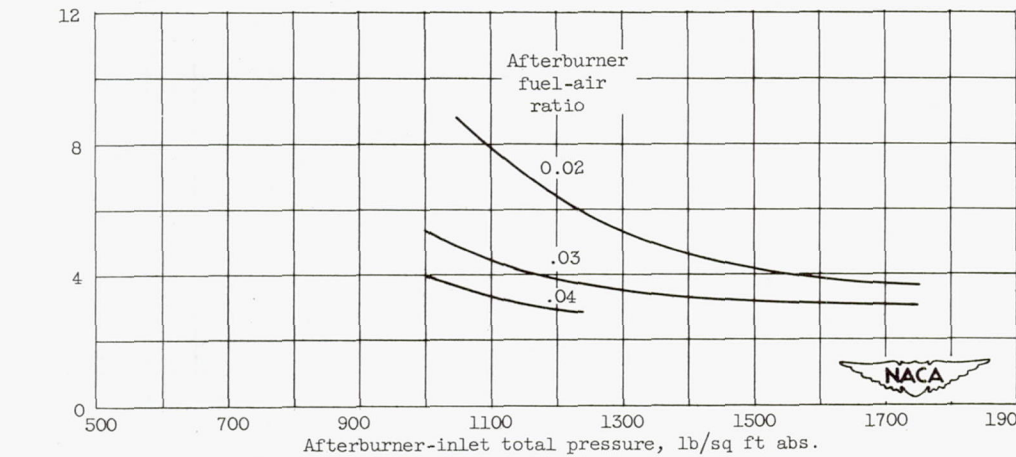

(c) Torch igniter B.

Figure 9. - Effect of afterburner-inlet total pressure on afterburner ignition time. Flight Mach number, 0.60.

2787

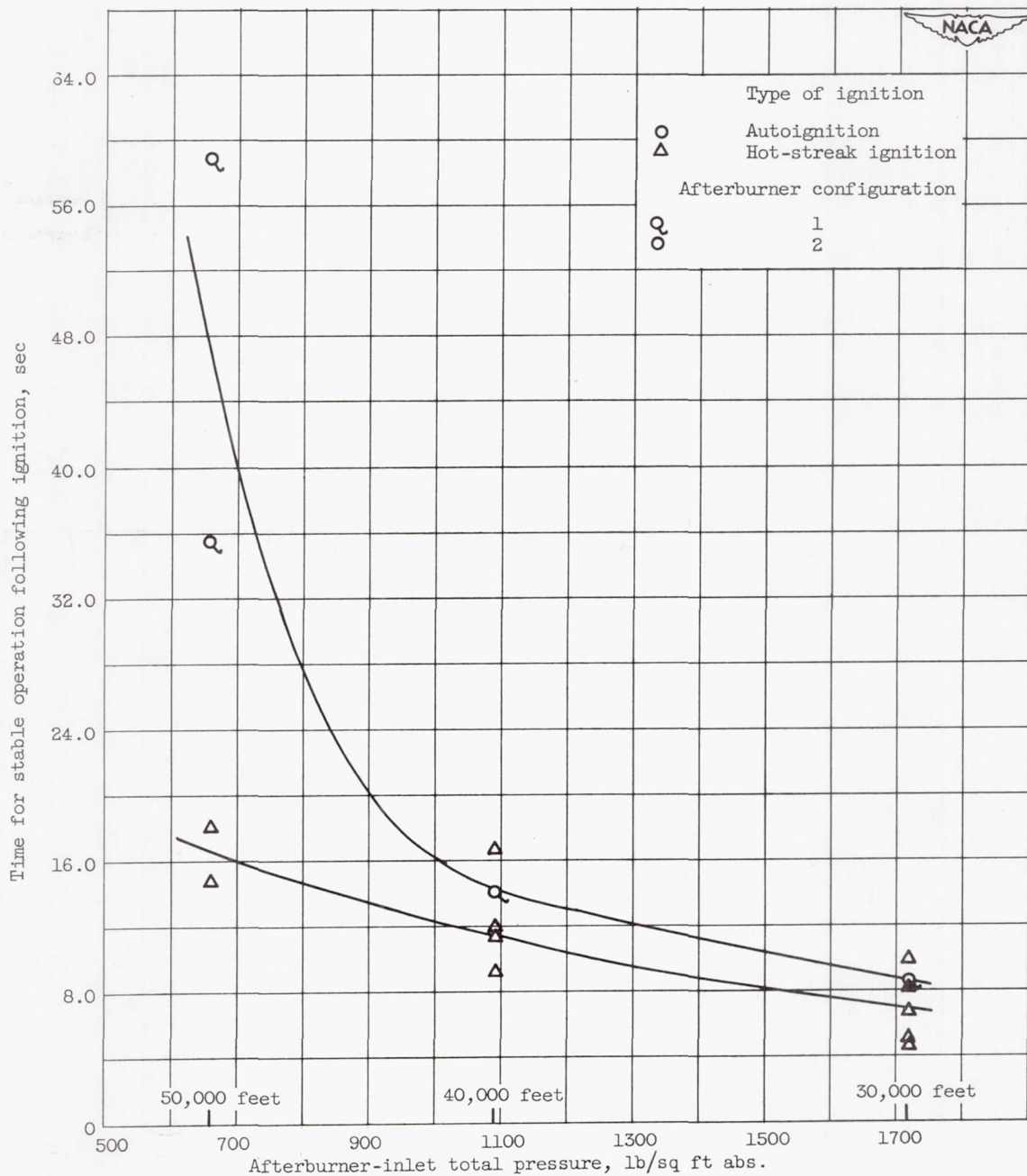
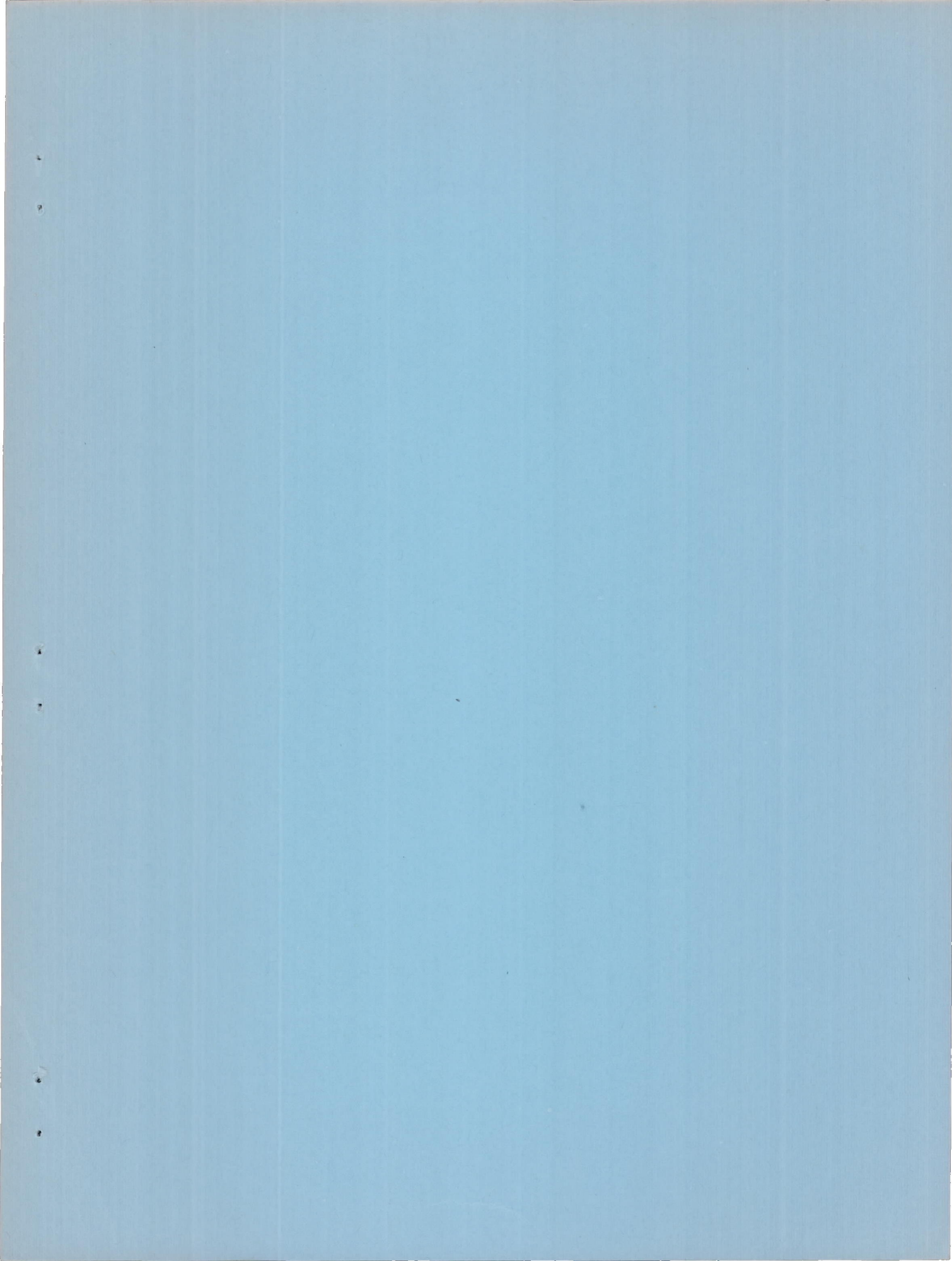

Figure 10. - Effect of afterburner-inlet total pressure on time required for stable operation following ignition. Flight Mach number, 0.60.





SECURITY INFORMATION
CONFIDENTIAL

CONFIDENTIAL