

NACA RM L53H06

RM L53H06

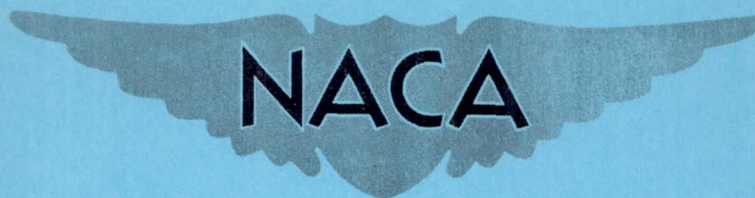

RESEARCH MEMORANDUM

EXPLORATORY INVESTIGATION OF TRANSPIRATION COOLING TO
ALLEVIATE AERODYNAMIC HEATING ON AN 8° CONE IN A
FREE JET AT A MACH NUMBER OF 2.05

By William J. O'Sullivan, Leo T. Chauvin,
and Charles B. Rumsey

Langley Aeronautical Laboratory
Langley Field, Va.

NATIONAL ADVISORY COMMITTEE
FOR AERONAUTICS
WASHINGTON

September 14, 1953
Declassified September 17, 1958

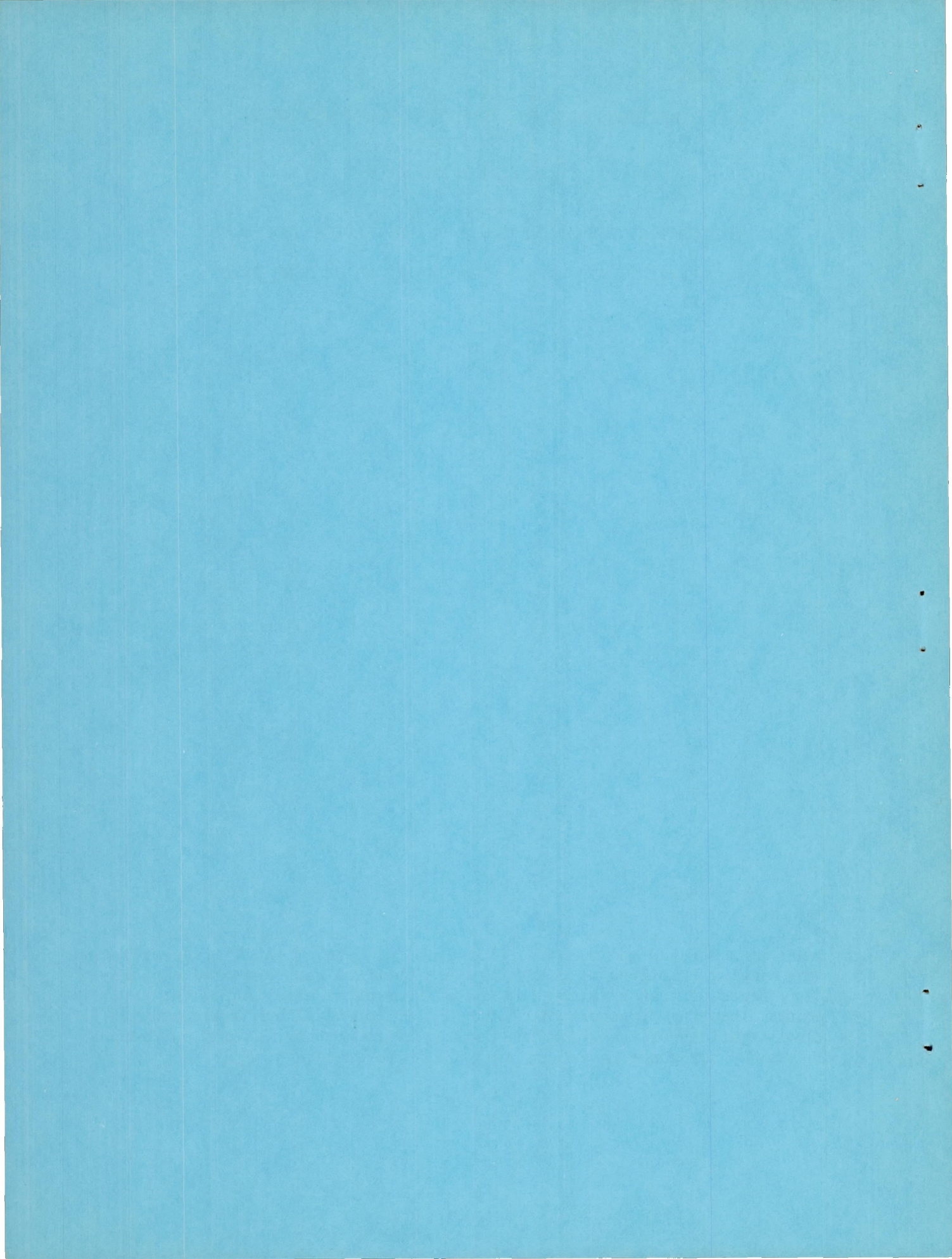

NATIONAL ADVISORY COMMITTEE FOR AERONAUTICS

RESEARCH MEMORANDUM

EXPLORATORY INVESTIGATION OF TRANSPIRATION COOLING TO
ALLEVIATE AERODYNAMIC HEATING ON AN 8° CONE IN A
FREE JET AT A MACH NUMBER OF 2.05By William J. O'Sullivan, Leo T. Chauvin,
and Charles B. Rumsey

SUMMARY

Tests have been made of the effectiveness of transpiration cooling of an 8° total angle conical body, wherein water was liberated onto the surface through a porous section near the nose, while subject to aerodynamic heating at Mach number 2.05, at a Reynolds number of 11.1×10^6 based on body length, and at a stagnation temperature of about 550° F. The surface of the conical body was maintained at a temperature of 125° F by expenditure of approximately 2.7 pounds (0.33 gallon) of water per minute per square foot of cooled area. The cooled surface temperature was found to agree with that calculated on the basis of evaporation of the water film.

A reference test without transpiration cooling was made of recovery-factor and heat-transfer coefficient and the measured values are in agreement with theoretical values.

INTRODUCTION

The phenomenon of aerodynamic heating in supersonic flight has been investigated experimentally and correlated with theory (for example, refs. 1 and 2), and the destructive effects of aerodynamic heating have been demonstrated and reported (for example, refs. 3 and 4). Accordingly, the Langley Pilotless Aircraft Research Division has conducted exploratory tests of transpiration cooling as a means of alleviating the aerodynamic heating of supersonic aircraft. Theoretical and experimental investigations of transpiration cooling of rocket nozzles and surfaces heated by hot gases have been reported in references 5 to 8.

Herein are reported tests of the effectiveness of transpiration cooling in alleviating aerodynamic heating. Water was used as the coolant and was liberated upon the surface of a conical body through a porous section near the nose of the model while the body was subject to aerodynamic heating in a free jet at approximately sea-level conditions and having a stagnation temperature of 550° F. The cooling process is assumed to be that of evaporation of the liquid film, and calculations of the equilibrium temperature under steady cooling are presented.

SYMBOLS

M	Mach number
V	velocity, ft/sec
h	local heat-transfer coefficient, Btu/(sec)(sq ft)($^{\circ}$ F)
T_w	skin temperature, $^{\circ}$ R
T_l	local temperature outside the boundary layer, $^{\circ}$ R
T_o	stream stagnation temperature, $^{\circ}$ R
T_{aw}	adiabatic wall temperature, $^{\circ}$ R
τ	skin thickness, ft
d	mass density of wall, lb/cu ft
c	specific heat of skin, Btu/(lb)($^{\circ}$ F)
t	time, sec
l	length from the apex of cone along the axis of the model, ft
μ	absolute viscosity of air, (lb)(sec)/sq ft
C_p	specific heat of air at constant pressure, Btu/(slug)($^{\circ}$ F)
k	thermal conductivity of air, Btu/(sec)(ft)($^{\circ}$ F)
Nu	Nusselt number, hl/k , dimensionless
Pr	Prandtl number, $C_p\mu/k$, dimensionless

R Reynolds number, $\rho V l / \mu$
 ρ density of air, slugs/cu ft

TEST APPARATUS AND MODEL

Preflight Jet

The preflight test apparatus used for this investigation is located at the Langley Pilotless Aircraft Research Station at Wallops Island, Va. Air for the operation of the preflight jet was stored in two spheres having a total volume of 25,000 cubic feet and at a pressure of 220 pounds per square inch absolute. A hydraulically controlled valve regulated the air from the spheres. The air then passed through a heat exchanger where it was heated to approximately 600° F, sufficient to compensate for the adiabatic temperature drop through the supersonic nozzle. The air then passed through a three-dimensional nozzle and exhausted to the atmosphere. Various Mach numbers can be obtained by interchanging the nozzle. The air supply was sufficient to enable continuous testing for approximately 50 seconds at the desired flow conditions. A shadowgraph system is provided for flow observation.

Model

The conical model used for these tests is shown in figure 1 installed in the test position in the 8-inch-diameter jet. Details of construction of the model are presented in figure 2. The total apex angle was 8°. A 1-inch-wide circumferential band of porous material through which the cooling water emerged was installed flush with the cone surface and extended over the region from 2.52 to 3.52 inches from the apex. This porous band was constructed of calendered metal filter cloth woven from Monel wire. Prior to calendering, the wire cloth was of twill Dutch weave with a warp count of 30 wires per inch of 0.010-inch diameter and a fill count of 250 wires per inch of 0.008-inch diameter. The thickness and porosity of the wire cloth were reduced by rolling and hammering to a thickness of 0.017 inch, yielding a porous surface devoid of protuberances. The porous band was formed by wrapping the wire cloth into the form of a frustrum of a cone and joining by means of a silver-soldered butt joint. The longitudinal butt joint produced a nonporous strip of approximately 1/8-inch width. Behind the porous section the model was constructed of 0.0315-inch-thick Inconel.

Cooling System

The cooling water was piped to the porous band and the mass rate of flow measured by means of the system shown in figure 3. The water was

forced from the storage tank by nitrogen gas applied through a pressure regulator. The water passed through a filter, a metering orifice, and then to the porous band by a pipe inside the conical model. The water employed was not distilled or otherwise treated. The mass rate of flow of the cooling water was continuously measured during the tests by automatically recording the pressure drop across the calibrated metering orifice. The pressure drop across the metering orifice was made large compared to any conceivable fluctuation in water pressure downstream of the orifice to insure constant mass rate of flow. At the lowest water mass-flow rate employed it was observed that the water tended to issue only from the bottom side of the porous band. This was overcome by packing absorbent cotton into the space underneath the porous band, shown in figure 2, and removing the metering orifice so that the water pressure drop occurred through the absorbent cotton which then served as the metering orifice. Measurement of the mass rate of water flow through the absorbent cotton metering system, and also check measurements of the system employing the metering orifice, were made immediately before and after each test by measuring with a stop watch the time required for a measured amount of water to be discharged. The temperature of the cooling water was measured with mercury-in-glass thermometers. The supply of cooling water was permitted to attain approximately atmospheric temperature before use to insure minimum variation of water temperature during the tests. The exterior surface of the model and the porous band were scrubbed with a 10 percent by volume water solution of commercially pure alkyl aryl polyether alcohol, which is a detergent and wetting agent, to remove grease or other matter. Cleansing of the model was considered adequate when water poured over the model was observed to form an unbroken, adherent film.

Temperature Measurements

In order to provide measurements of the skin temperature of the model, a total of 28 iron-constantan thermocouples made of No. 32 gage wire were imbedded in the Inconel skin behind the porous band. The locations of the thermocouples are shown in figure 2. The thermocouples were arranged in four rows of seven thermocouples each, the rows being along elements of the cone spaced 90° apart. The thermocouples were spaced 1 inch apart in the rows, the first thermocouples being 4.58 inches and the last 10.58 inches from the apex. The thermocouples were installed by drilling through the skin the smallest hole into which the thermocouple would fit, inserting the thermocouple, filling the hole with silver solder, and smoothing the exterior surface. The thermocouple leads were taken out through the base of the model and down the rear of the model support strut, as shown in figure 1. A common cold junction was employed. Continuous time histories of the thermocouple potentials were automatically recorded during the tests on multiple-channel recording galvanometers. All automatically recorded measurements were time-synchronized by a 10-cycle-per-second electrical timing system.

TESTS

All tests were performed with the model mounted in the jet at zero angle of attack and angle of yaw, as shown in figure 1.

The tests with water transpiration cooling were performed by first setting the mass rate of flow of the cooling water and then starting the supersonic air jet. Approximately 5 to 8 seconds are required for the jet to establish steady flow from the nozzle at Mach number 2.05. Steady flow was maintained until several seconds after the measurements of skin temperature indicated that the model had attained essentially equilibrium temperature. Data are presented for two tests, one where it was observed that cooling occurred over the entire instrumented length of the model, and another test at a reduced rate of coolant flow where only part of the model was cooled.

In order to provide a basis for evaluating the effectiveness of the water transpiration cooling, a test was performed without water cooling. This reference test provided measurements of the recovery factor and the heat-transfer coefficient in the dry condition.

RESULTS AND DISCUSSION

Reference Test Without Cooling

Recovery factors.- The boundary-layer recovery factor in the test without cooling is defined as

$$\frac{T_{aw} - T_1}{T_0 - T_1}$$

wherein T_{aw} is the adiabatic wall temperature, T_1 is the local temperature just outside the boundary layer, and T_0 is the stream stagnation temperature. The effects of radiation and heat conduction along the skin on the heat transfer were calculated and found to be negligible compared to the heat transferred to the skin from the boundary layer. The supply of air in the storage spheres and the supply of heat in the heat exchanger of the preflight test apparatus limited the duration of the test under steady flow condition to about 50 seconds, so that equilibrium conditions could be approached closely but not actually attained. Therefore, the measured ratio of skin temperature to stagnation temperature for each thermocouple was plotted against the reciprocal of time, and the nearly linear curves so obtained extrapolated to infinite time. From the values at infinite

time thus obtained, the recovery factors were computed. The recovery factors are shown in figure 4 plotted against distance behind the porous band. For comparison are shown the theoretical recovery factors for a laminar and for a turbulent boundary layer, as given in references 9 and 10, respectively, wherein the laminar recovery factor is found to be the square root of the Prandtl number, and the turbulent recovery factor the cube root of the Prandtl number. The Prandtl number was based upon air conditions just outside the boundary layer, which conditions are theoretically constant along a cone. The close agreement of the recovery factors with the theoretical value for a turbulent boundary layer indicates that the boundary layer was turbulent. The test Reynolds number, based upon conditions just outside the boundary layer, was 13×10^6 per foot. The Reynolds number, based on distance from the apex of the model, therefore varied linearly from 4.96×10^6 at the most forward thermocouple to 11.48×10^6 at the most rearward thermocouple. A turbulent boundary layer would therefore be expected. Also, the roughness of the porous band and weak shock waves originating from the nozzle and intersecting the model as shown in figure 5 would be expected to cause the boundary layer to be turbulent.

Heat-transfer coefficients.- The aerodynamic heat-transfer coefficient was measured during the transient heating of the uncooled model after the establishment of steady air flow from the nozzle. The rate of heat transfer per unit of model surface area per unit of time is

$$h(T_{aw} - T_w)$$

The accumulation of heat in the model skin per unit of model surface area per unit of time is

$$\tau dc \frac{dT_w}{dt}$$

Equating the rate of heat flow into the skin to the rate of accumulation of heat in the skin and solving for the aerodynamic heat-transfer coefficient gives

$$h = \frac{\tau dc \frac{dT_w}{dt}}{T_{aw} - T_w}$$

The aerodynamic heat-transfer coefficients were evaluated by this equation taking the mass density of the Inconel skin as 530.5 pounds per cubic foot and its specific heat as 0.109 Btu per pound of mass per degree Fahrenheit. The skin temperature and its time rate of change were obtained from the measured time histories of the skin temperature. The adiabatic wall temperature was computed by using the experimentally determined recovery factors.

In order to facilitate comparison with theory, the measured aerodynamic heat-transfer coefficients are presented in figure 6 as the Nusselt number divided by the cube root of the Prandtl number plotted against the Reynolds number. In computing the Nusselt number, the Prandtl number, and the Reynolds number, the air properties and velocity were based upon conditions just outside the boundary layer, and the length was taken as the distance from the apex of the cone to the measurement station. Results are presented for ratios of skin temperature to temperature just outside the boundary layer of 1.48, 1.52, and 1.56. For comparison is shown the curve of the theoretical heat transfer upon a cone for a turbulent boundary layer at a value of the thermal ratio T_w/T_1 of 1.52, as given in reference 11. The theoretical curves for thermal ratios of 1.48 and 1.56 fall, respectively, upon the upper and lower edges of the curve for thermal ratio 1.52, and accordingly are not shown. Also is shown the laminar boundary-layer heat-transfer curve for a cone, as given in reference 12. The agreement of the experimental values with the turbulent boundary-layer theory substantiates the indication of the recovery-factor measurements that the boundary layer was turbulent in the region of measurement.

The experimental points in figure 6 form seven groups at different Reynolds numbers corresponding to the seven longitudinal positions upon the model at which thermocouples were installed. It is interesting to note that below a Reynolds number of about 7.5×10^6 the experimental points in figure 6 tend to fall below the theoretical turbulent curve, whereas above this Reynolds number they tend to fall above the curve.

The Reynolds number of 7.5×10^6 approximately coincides with the place at which a disturbance from the lip of the jet nozzle impinged upon the model, as shown by the shadowgraph of figure 5.

Cooling Test With 0.010 Pound of Water Per Second

The distribution of skin temperature T_w measured on the model with a cooling water mass-flow rate of 0.010 pound per second is shown in figure 7. The cooling water entered the model at a temperature of 52° F. The air-jet Mach number was 2.05, the Reynolds number per foot of length was 12.6×10^6 , the free-stream temperature was 87° F, the stagnation temperature was 552° F, and the free-stream pressure was 13.6 pounds per

square inch absolute. Disregarding all disturbances to the flow except the conical shock wave emanating from the apex of the cone, the air just outside the boundary layer of the cone is computed to have a Mach number of 2.0, a Reynolds number per foot of length of 13.05×10^6 , a temperature of 103° F, and a pressure of 14.7 pounds per square inch absolute. Under these conditions the water transpiration cooling maintained the model skin behind the porous band at a temperature of about 125° F. The four types of experimental point symbols shown in figure 7 refer to the four rows of thermocouples spaced 90° apart around the model. The cooling is uniform both longitudinally and circumferentially. For comparison is shown the adiabatic wall temperature, or skin equilibrium temperature, of 500° F that would have been attained in the absence of water transpiration cooling. This adiabatic wall temperature was computed from the recovery factors measured in the reference test without cooling. The coolant water mass-flow rate of 0.010 pound per second thus maintained the skin at a temperature 375° lower than without cooling. After the attainment of steady air flow, the cooling was maintained for a period of 50 seconds and gave no evidence of fluctuation.

Cooling Test with 0.0025 Pound of Water Per Second

An endeavor was made to perform cooling tests at progressively lower water mass-flow rates in order to establish the variation of equilibrium skin temperature with water mass-flow rate and to explore the condition wherein the water flow rate would be inadequate to accomplish cooling over the entire length of the model skin in which thermocouples were imbedded. At water mass-flow rates of 0.0075 and 0.0050 pound per second, using the metering orifice located in the coolant water line approximately 4 feet from the porous band, the skin-temperature measurements indicated nonuniform circumferential distribution of water, with cooling occurring predominantly on the bottom side of the model. Also, the cooling was unsteady, there occurring bursts of cooling presumably due to the cavity underneath the porous band partially emptying of water. It was found that, by removing the metering orifice from the water line and packing the cavity beneath the porous band with absorbent cotton, steady water flow could be maintained with considerably improved circumferential distribution. The water pressure drop through the absorbent cotton effectively provided a metering orifice. Evidently there must exist a pressure drop through the porous band to effect steady and circumferentially uniform water distribution.

With the absorbent cotton system a cooling test was made with a water mass-flow rate of 0.0025 pound per second. This water-flow rate was inadequate to produce cooling over the entire length of the model skin in which thermocouples were embedded. Time histories of the skin temperatures measured by the thermocouples are shown in figure 8. The

temperature curves bear the numbers of the thermocouples whose locations are shown in figure 9. Thermocouples numbers 8 and 16 malfunctioned and are not reported. Inspection of the temperature time histories in figure 8 shows that, after the establishment of approximately steady test conditions at about 20 seconds, there occurred moderately steady cooling until about 28 seconds, at which time deterioration of the cooling is observed to begin. This deterioration of cooling is believed to be associated with the formation of a grey deposit upon the model. It was observed that in regions near the porous band, where cooling was definitely maintained, there was no evidence of deposit, whereas farther rearward on the model where cooling was not maintained, there was deposit. Tests in which samples of the cooling water were evaporated from a sheet of Inconel showed similar deposits. It was also observed that water poured upon the portion of the model surface free of deposit did not appear to wet the surface and form an adherent film as readily as before the test, giving evidence that the wetting agent with which the model had been washed prior to the test had been partially removed during the test. Tests in which samples of the wetting agent were evaporated from a sheet of Inconel showed no deposit. Evidently distilled water should be employed to which a small quantity of wetting agent has been added.

In figure 9 is shown upon a development of the model skin the temperature contours taken at 26 seconds from the time histories of figure 8. This time is representative of equilibrium conditions and is after the decay of the starting transients, but before the noticeable onset of model surface contamination. At 26 seconds the air-jet Mach number was 2.05, the Reynolds number per foot of length was 12.65×10^6 , the free-stream temperature was 88° F, the stagnation temperature was 575° F, and the free-stream pressure was 13.6 pounds per square inch absolute. Disregarding all disturbances to the flow except the conical shock wave emanating from the apex of the cone, the air just outside the boundary layer of the cone is computed to have a Mach number of 2.0, a Reynolds number per foot of length of 12.9×10^6 , a temperature of 100° F, and a pressure of 14.7 pounds per square inch absolute. The temperature of the cooling water entering the model was 50° F.

The temperature contours of figure 9 show that the coolant water mass-flow rate of 0.0025 pound per second maintained the model skin at between 113° F and 125° F at the first, second, and almost to the third circumferential band of thermocouples behind the porous section. From this point rearward the skin temperature rises rapidly towards the adiabatic wall temperature of 498° F, computed from the recovery factors measured in the reference test without cooling. The temperature contours show the existence of a cool streak extending farther downstream than the most rearward band of thermocouples. This cool streak may be caused by any of the following conditions: irregularities in the air flow or in the distribution of coolant around the model, a slight angle of attack of the model, or the presence of the 1/8-inch-wide nonporous seam in the porous

band. Thermocouple number 11 indicated a temperature of 140° F, which is higher than that shown by thermocouples both upstream and downstream of it. Reexamination of this thermocouple showed no evidence of malfunctioning.

A shadowgraph of the flow about the model taken at approximately 26 seconds during the test with coolant water mass-flow rate of 0.0025 pound per second is shown in figure 10. A disturbance originating from the lip of the supersonic nozzle is observed to impinge upon the model between the third and fourth circumferential bands of thermocouples behind the porous band. Comparison of the point of impingement of this disturbance with the temperature contours of figure 9 shows that the rapid rise of skin temperature begins upstream of this point of impingement, indicating that the start of the rapid rise of skin temperature is probably not associated with the disturbance impingement.

Hypothesis of the Phenomena of Liquid Transpiration Cooling

The phenomenon of the alleviation of aerodynamic heating by liquid transpiration cooling is assumed to be one involving evaporation to the point of saturation of the air adjacent to the liquid film. It is assumed that upon emerging at the surface of the body the cooling liquid is carried back over the body surface in the form of a thin film by the friction drag. The cooled region is considered divisible into three parts. The first region extends from the point of emergence of the cooling liquid back to the place where the skin temperature under steady cooling becomes approximately constant with distance along the surface. In this first region the temperature of the liquid film is assumed to change from the temperature at which the liquid emerges to the approximately constant skin temperature of the second region. The second region is that where the skin temperature under steady cooling is approximately constant with distance along the surface. The liquid film is assumed to terminate at the downstream end of this second region. The third region is that in which the skin temperature rises from the approximately constant temperature of the second region toward the adiabatic wall temperature that would exist without cooling. Thus the first and third regions are considered transition regions, whereas the second region is considered one of steady cooling.

In the second region it is assumed that at the air-liquid interface the flux of heat into the liquid film from the air is exactly equal to the flux of heat out of the liquid film by the process of evaporation. At the air-liquid interface, which is at the bottom of the boundary layer, the velocity of the air relative to the body approaches zero, and the air adjacent to the liquid film is assumed saturated with the vapor of the liquid. For liquids whose vapor does not undergo chemical reaction with the air during evaporation, the mass of vapor required to produce saturation of a unit mass of air at a given pressure is a function of

temperature (ref. 13). For any given pressure a graph can therefore be constructed upon which is plotted a curve of the mass of vapor required to produce saturation of a unit mass of air as a function of temperature. The temperature at the air-liquid interface must then lie somewhere along this saturation curve.

It is assumed that the point along the saturation curve representing the temperature at the air-liquid film interface in the second region can be determined in the following manner. In the absence of transpiration cooling the temperature attained by the air adjacent to the skin at the bottom of the boundary layer under steady conditions is the adiabatic wall temperature. Evaporation of the cooling liquid into this heated air can proceed until saturation is attained. The evaporation lowers the temperature of the air by virtue of the heat of vaporization of the liquid. In accord with the conservation of energy, the change in enthalpy, or total heat content, of the unit mass of air in cooling from adiabatic wall temperature to saturation temperature is equal to the heat of vaporization of the liquid required for saturation of the unit mass of air. There may be calculated the point upon the saturation curve where evaporation of the liquid into the air to the extent of saturation lowers the temperature exactly to the saturation curve. The temperature on the saturation curve thus determined is assumed to be the temperature at which evaporation is taking place. This temperature is also the temperature of the liquid film as well as that of the skin, in accord with the assumption that in the second region the flux of heat into the liquid film from the air is exactly equal to the flux of heat out of the liquid film by the process of evaporation.

Comparison of Measured Skin Temperature

With That Predicted by Hypothesis

The transpiration cooling test at a water mass-flow rate of 0.01 pound per second produced an approximately constant temperature over the entire length of the model's skin in which thermocouples were embedded. This nearly constant temperature region is assumed to be the second region of the foregoing hypothesis. The skin temperature predicted by the hypothesis can be conveniently determined for this test by the graph shown in figure 11.

Disregarding all disturbances to the flow except the shock emanating from the apex of the conical model, the pressure upon the surface of the model is computed to be 14.7 pounds per square inch absolute. Figure 11 has been computed for standard sea-level pressure of 14.7 pounds per square inch absolute and for a turbulent boundary layer. Just outside the boundary layer the Mach number is computed to be 2.0 and the temperature 103° F. Beginning at the temperature of 103° F on the scale labeled T_1 , temperature just outside boundary layer, and proceeding

upward, as shown by the broken line, to the curve for Mach number 2.0 representing the Mach number just outside the boundary layer, and then across the figure to the temperature scale, the uncooled adiabatic wall temperature is found to be 500° F. The curves running from the left-hand temperature scale down to the saturation curve are curves of constant enthalpy. Proceeding from the dry adiabatic wall temperature along a line of constant enthalpy to the saturation curve and then across to the left-hand temperature scale, as shown by the broken line, the transpiration cooled skin temperature predicted by the hypothesis is found to be 125° F, which is, within the experimental accuracy of the test, in agreement with the measured value of 125° F shown by figure 7.

Curves for Mach numbers 3 and 4 are also shown in figure 11. The effect of Mach number at sea-level pressure on the cooled skin temperature is seen to be small according to this method of prediction. Although the hypothesis provides a means of predicting the skin temperature under transpiration cooling at other Mach numbers, altitudes, and with other cooling liquids, it is considered that further tests should be performed before confidence could be placed upon such predictions.

Water Consumption

From the viewpoint of design of a transpiration cooling system, it is of interest to compute the amount of water required per unit of cooled area per unit of time. For the test at a water mass-flow rate of 0.0025 pound per second at 50° F, if the cooled area is considered to extend from the forward edge of the porous band back to the 125° F temperature contour, and all cooling farther downstream is disregarded, even the cool strip, the required cooling water is computed to be 2.72 pounds per square foot per minute or 0.326 gallon per square foot per minute. An ideal water jacket attached to the under surface of the skin and cooling the same area to the same temperature of 125° F with the inlet water temperature the same would require a water mass-flow rate approximately four times as great. This is because the water jacket does not make use of the heat of vaporization. Another comparison can be made in which the heat of vaporization is utilized. Assuming that the heat-transfer coefficient to the water film is the same as that to the dry skin, the heat prevented from entering the skin per unit of time is computed to be approximately 29 percent of the heat that the water mass-flow rate of 0.0025 pound per second is capable of absorbing in changing from water at the inlet temperature of 50° F to vapor at 125° F.

Concluding Remarks

The exploratory tests of transpiration cooling herein reported show that at a Mach number of about 2 under approximately sea-level conditions with a stagnation temperature of 550° F, a skin temperature of about 125° F can be maintained on an 8° total apex angle cone by liberation of water

onto the cone surface through a small porous section of skin. The water consumption rate is found to be about 2.7 pounds (about 0.33 gallon) per square foot of cooled surface per minute. The porous-band-transpiration cooling system employed in these exploratory tests gives promise of providing a lighter transpiration cooling system than one in which the entire cooled surface is porous and requires double-wall water-jacket-type construction.

An hypothesis of the cooling process is advanced by which the cooled skin temperature can be calculated. The calculated cool skin temperature is found to agree with that measured in the tests. Although the hypothesis provides a means of predicting the skin temperature under transpiration cooling at other Mach numbers, altitudes, and with other cooling liquids, it is considered that further tests should be performed before confidence could be placed upon such predictions.

The boundary-layer recovery factor measured on the uncooled 8° conical test body is in agreement with the theoretical value for a turbulent boundary layer, and the heat-transfer coefficients are in agreement with Van Driest's theory for turbulent boundary-layer heat transfer on a cone.

Langley Aeronautical Laboratory,
National Advisory Committee for Aeronautics,
Langley Field, Va., July 24, 1953.

REFERENCES

1. Chauvin, Leo T., and deMoraes, Carlos A.: Correlation of Supersonic Convective Heat-Transfer Coefficients From Measurements of the Skin Temperature of a Parabolic Body of Revolution (NACA RM-10). NACA RM L51A18, 1951.
2. Donaldson, Coleman duP.: Heat Transfer and Skin Friction for Turbulent Boundary Layers on Heated or Cooled Surfaces at High Speeds. NACA RM L52H04, 1952.
3. Heldenfels, Richard R., Rosecrans, Richard, and Girffith, George E.: Test of an Aerodynamically Heated Multiweb Wing Structure (MW-1) in a Free Jet at Mach Number 2. NACA RM L53E27, 1953.
4. Heldenfels, Richard R., and Rosecrans, Richard: Preliminary Results of Supersonic-Jet Tests of Simplified Wing Structures. NACA RM L53E26a, 1953.
5. Kinney, George R., Abramson, Andrew E., and Sloop, John L.: Internal-Liquid-Film-Cooling Experiments With Air-Stream Temperatures to 2,000° F in 2- and 4-Inch-Diameter Horizontal Tubes. NACA Rep. 1087, 1952. (Supersedes NACA RM E50F19 by Kinney and Sloop, NACA RM E51C13 by Kinney and Abramson, and NACA RM E52B20 by Kinney.)
6. Sloop, J. L., and Kinney, George R.: Internal-Film Cooling of Rocket Nozzles. NACA RM E8A29a, 1948.
7. Rannie, W. D.: A Simplified Theory of Porous Wall Cooling. Progress Rep. No. 4-50 Jet Propulsion Lab. C.I.T., 1947.
8. Wheeler, H. L., Jr.: Heat Transfer in Nitrogen and Hydrogen Sweat-Cooled Tubes. Progress Rep. No. 20-160. Jet Propulsion Lab., C.I.T., 1952.
9. Wimbrow, William R.: Experimental Investigation of Temperature Recovery Factors on Bodies of Revolution at Supersonic Speeds. NACA TN 1975, 1949.
10. Squire, H. B.: Heat Transfer Calculation for Aerofoils. R. & M. No. 1986, British A.R.C., 1946.
11. Van Driest, E. R.: Turbulent Boundary Layer on a Cone in a Supersonic Flow at Zero Angle of Attack. Jour. Aero. Sci., vol. 19, no. 1, Jan. 1952.

12. Johnson, H. A., and Rubesin, M. W.: Aerodynamic Heating and Convective Heat Transfer - Summary of Literature Survey. Trans. A.S.M.E., vol. 71, no. 5, July 1949, pp. 447-456.
13. Eckert, E. R. G. (with Appendix by Robert M. Drake, Jr.): Introduction to the Transfer of Heat and Mass. First ed., McGraw-Hill Book Co., Inc., 1950.

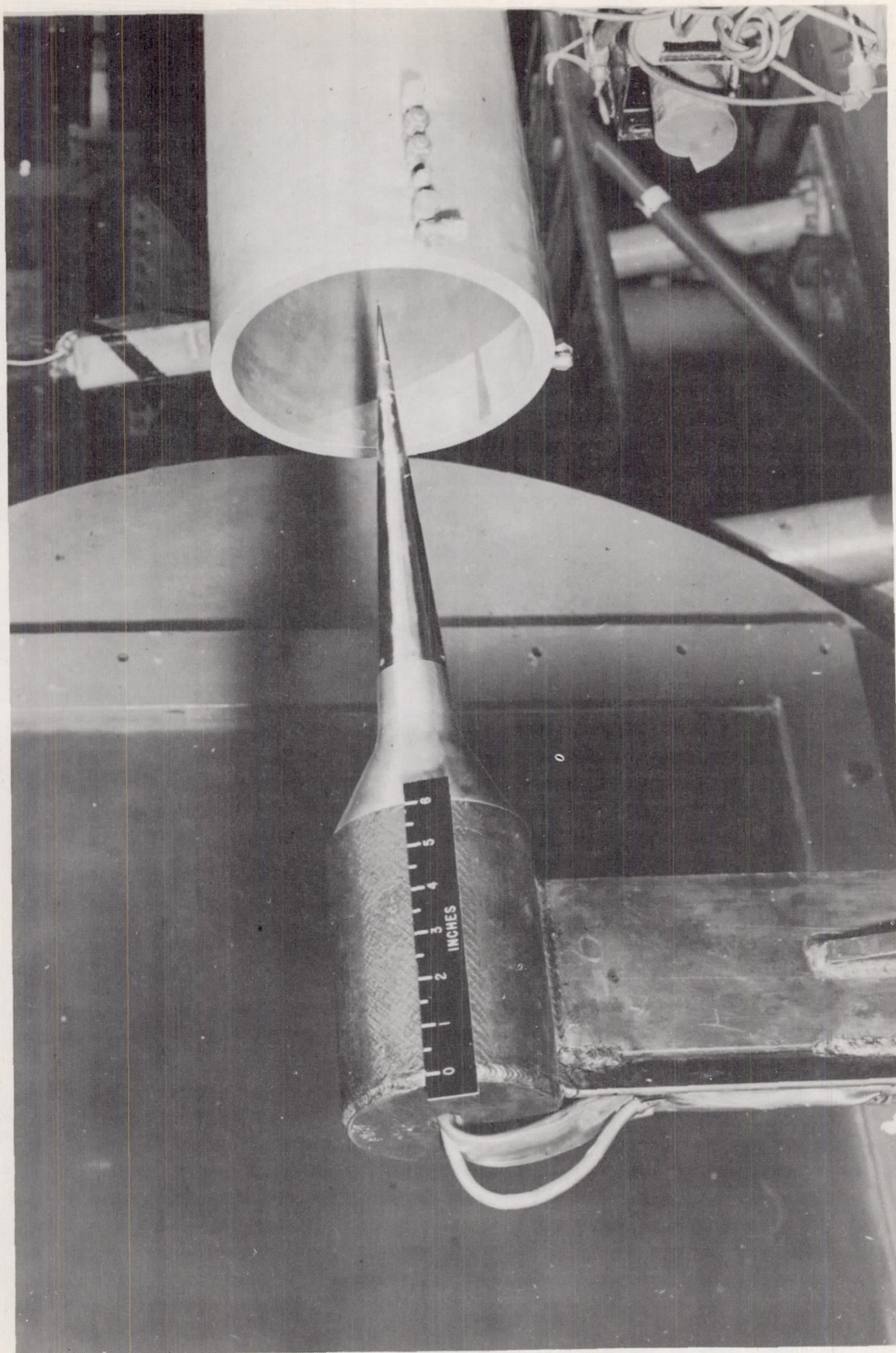

L-79376

Figure 1.- Model mounted in the 8-inch auxiliary jet.

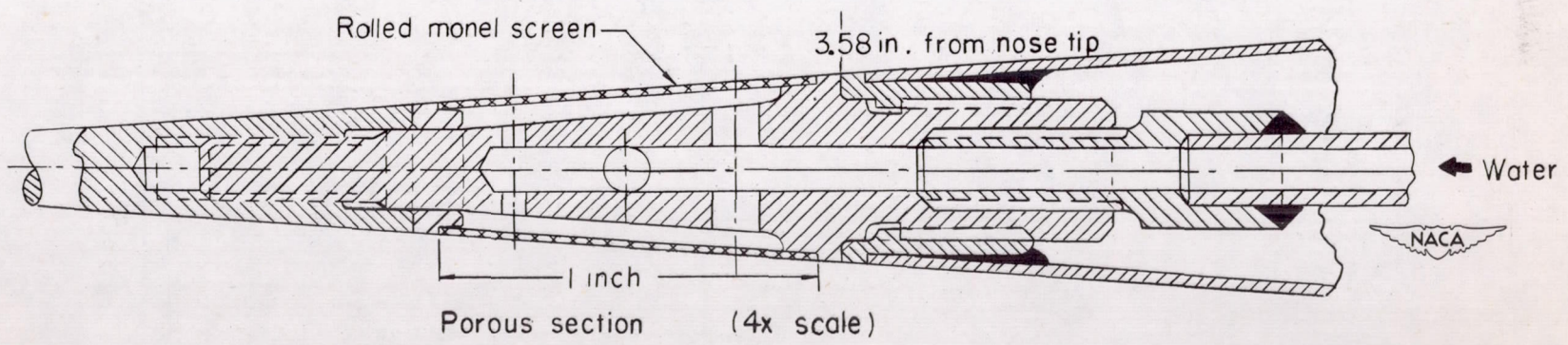
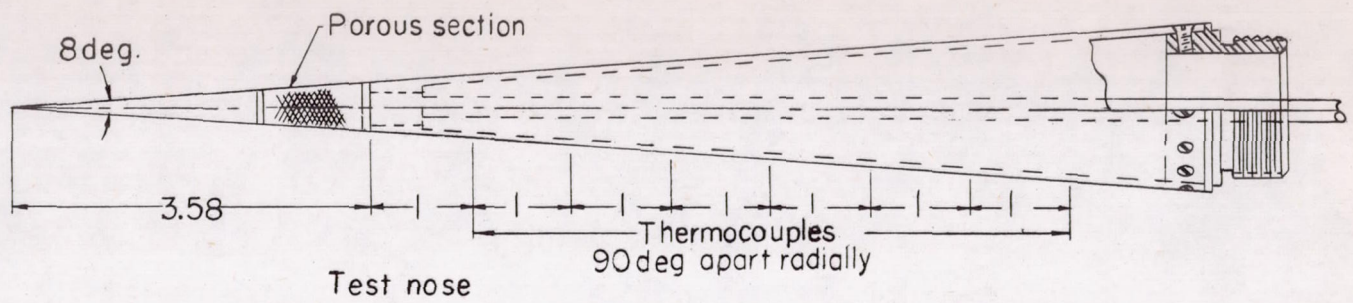

Figure 2.- Diagrammatic sketch of test model illustrating cooling mechanism.

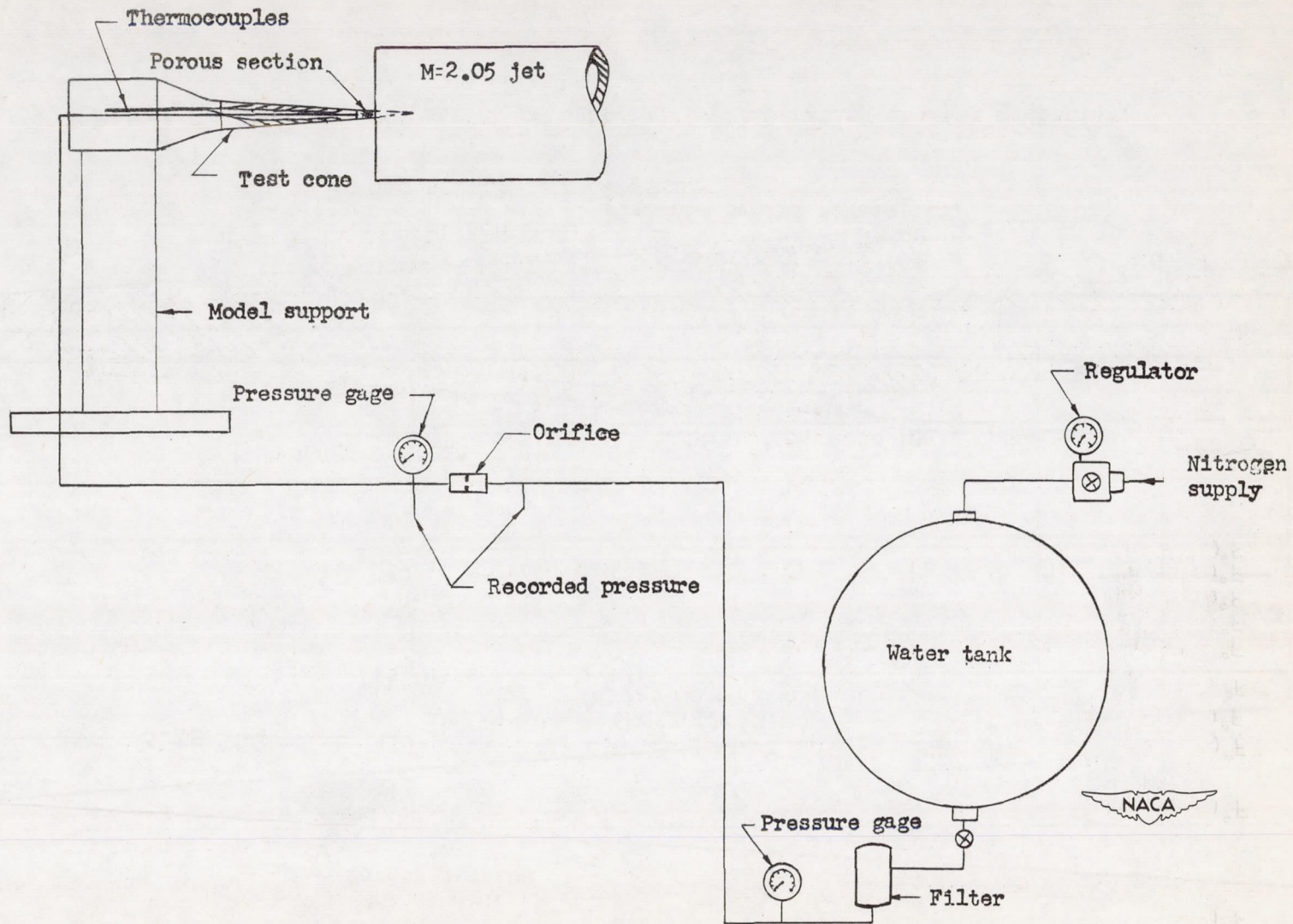

Figure 3.- Schematic drawing of water-injection system.

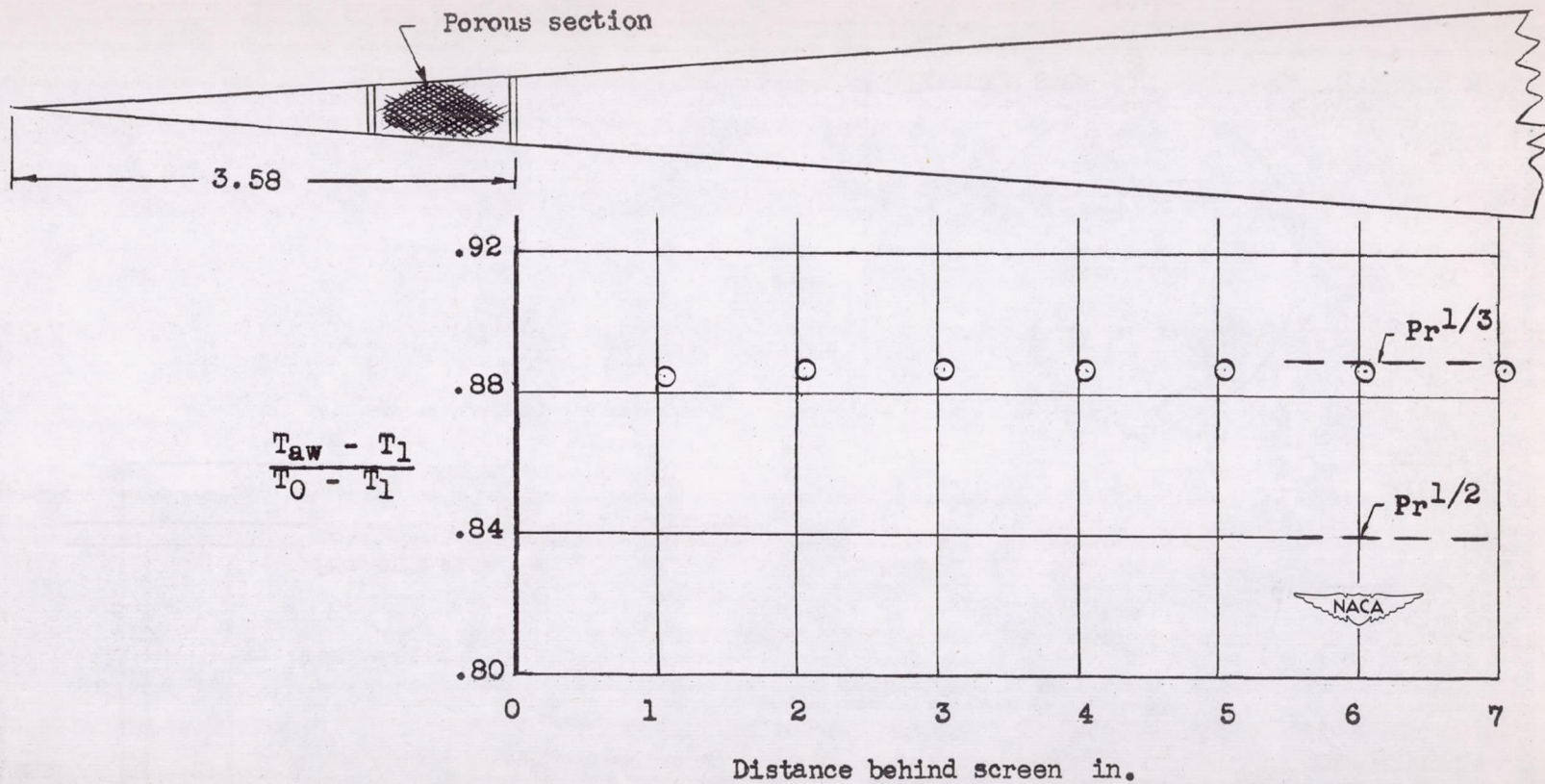

Figure 4.- Recovery factors measured on the model for the test without cooling.

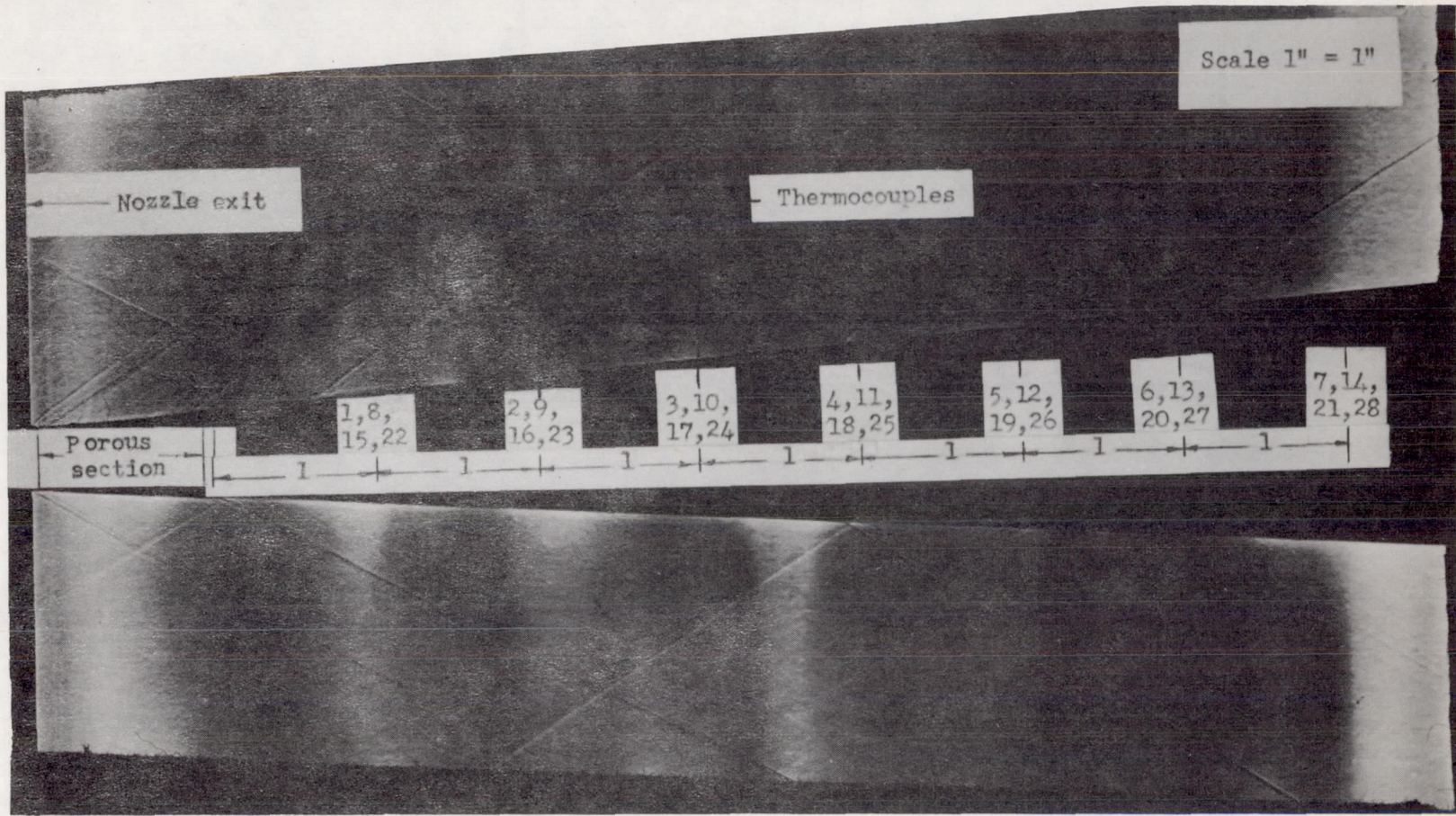

Figure 5.- Shadowgraph of test with no coolant flow.

L-80276

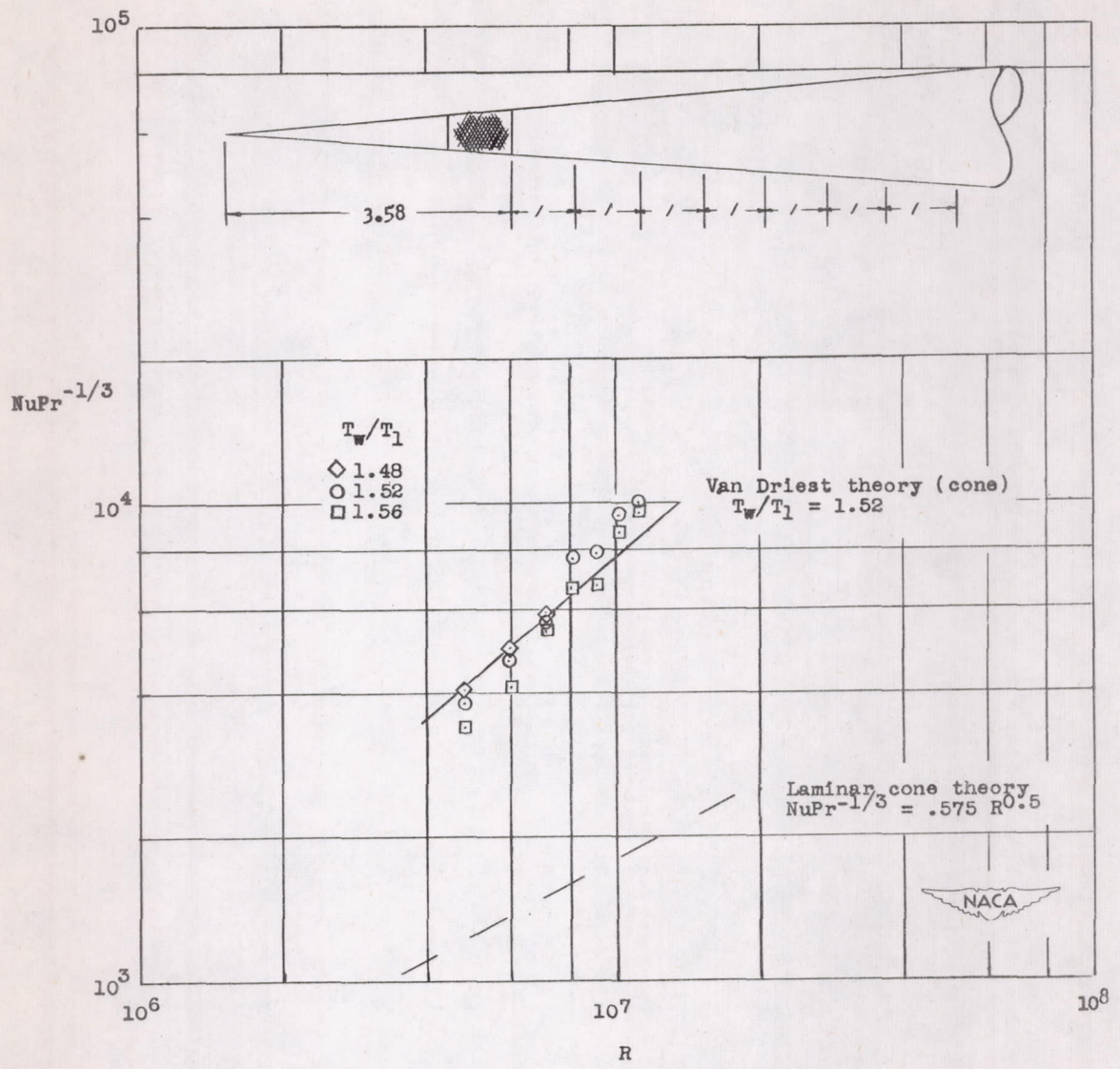

Figure 6.- Correlation of heat-transfer data for the test without cooling.

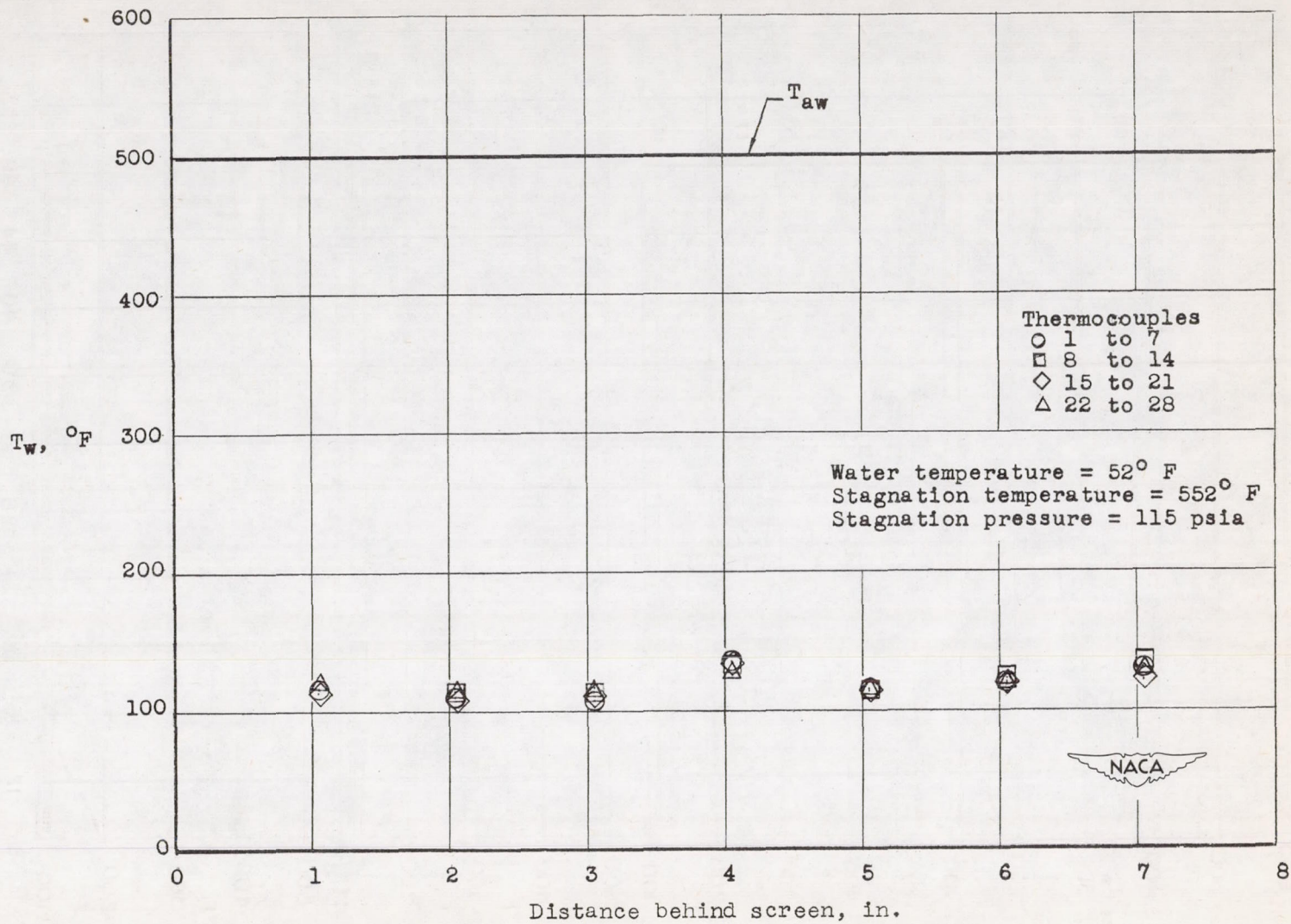

Figure 7.- Skin-temperature distribution on cone for water injection rate of 0.010 lb/sec.

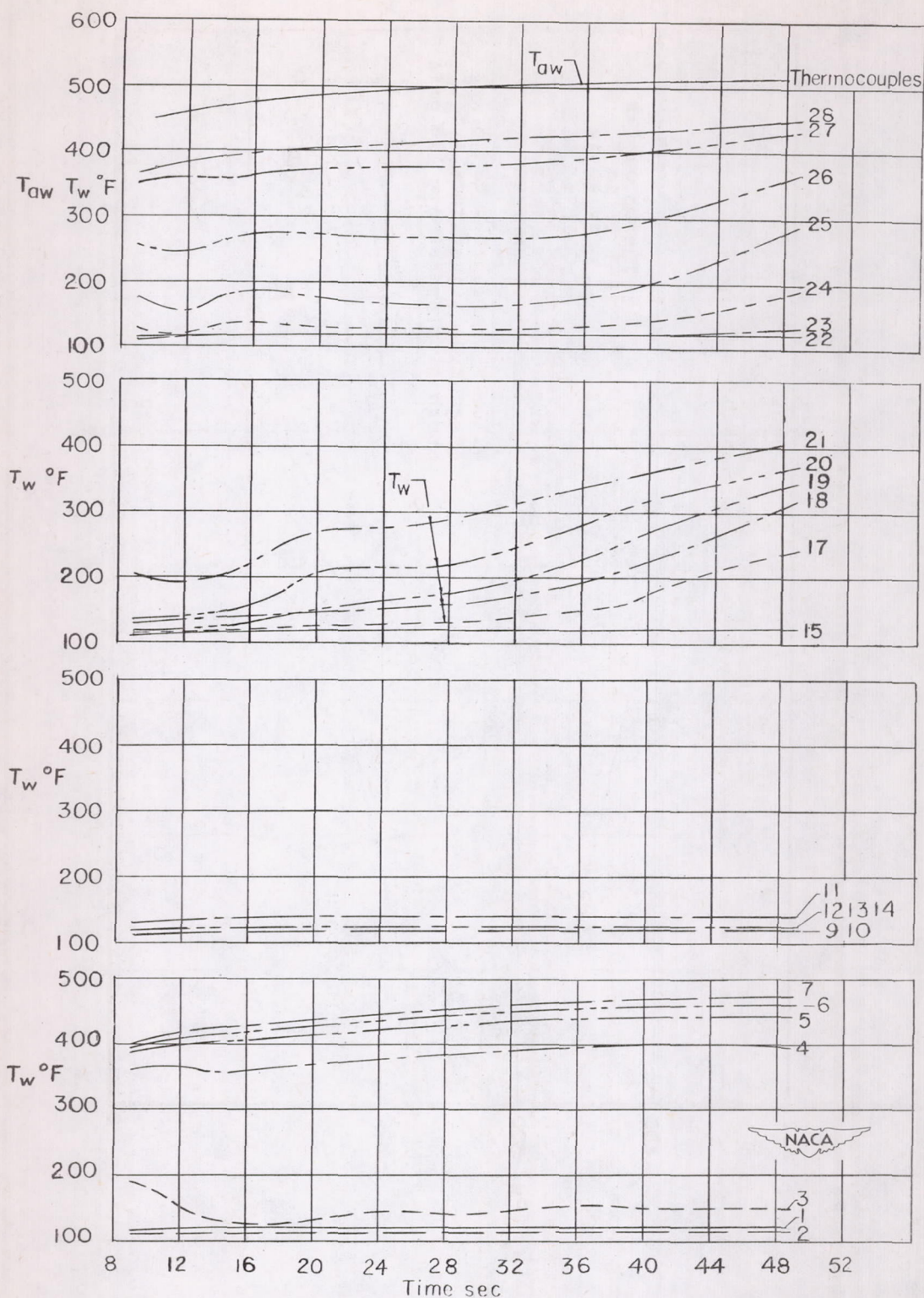

Figure 8.- Skin-temperature time histories for the test for 0.0025 pound of water per second.

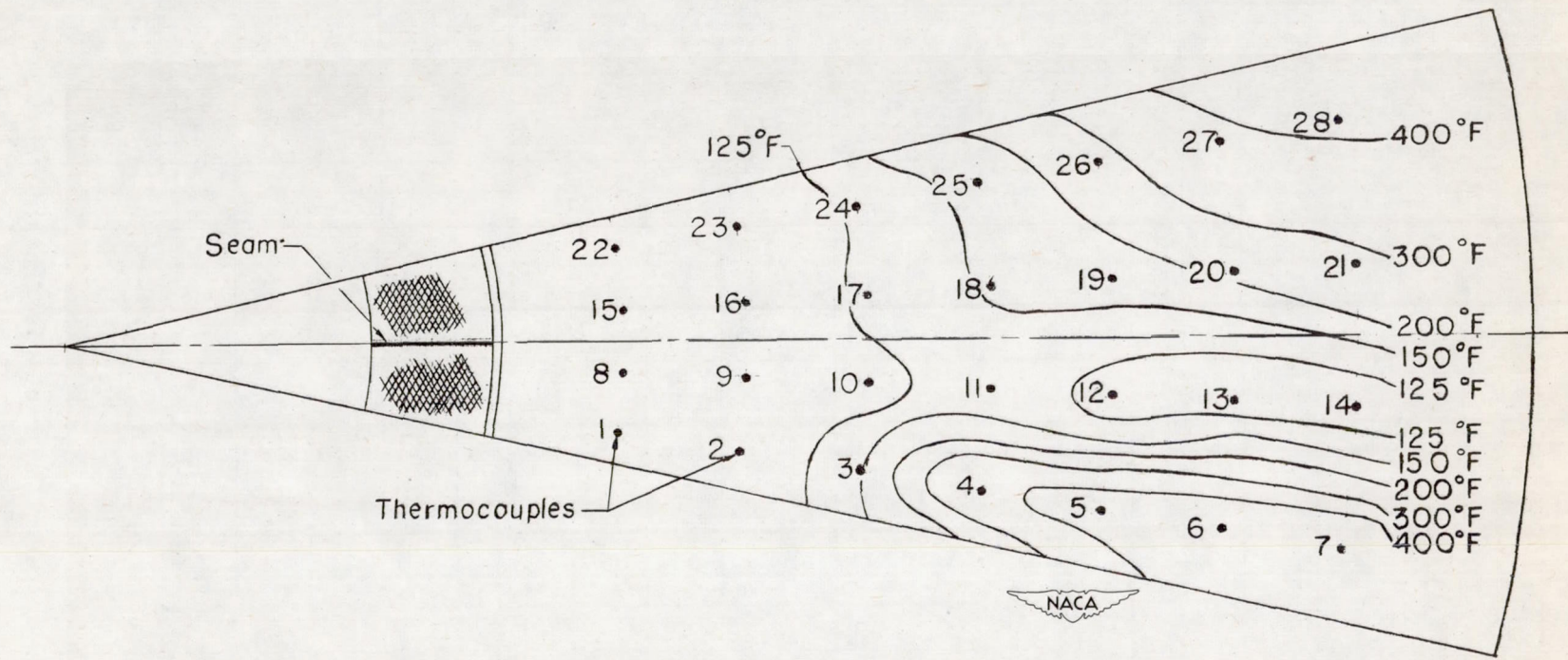
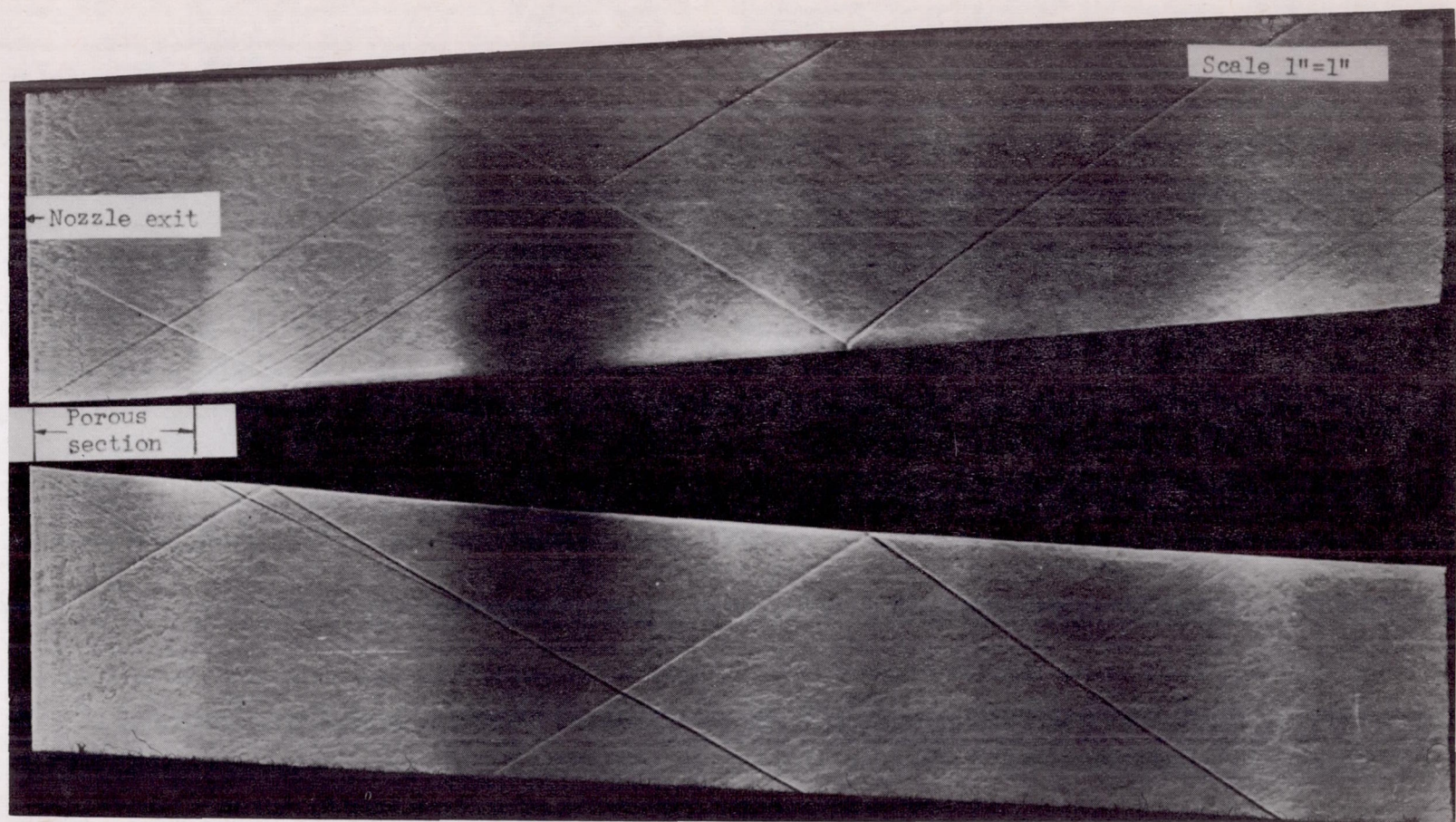

Figure 9.- Skin-temperature distribution on surface of cone for water rate of 0.0025 pound per second at 26 seconds.



L-80277

Figure 10.- Shadowgraph for the cooling test for a water rate of 0.0025 pound per second.

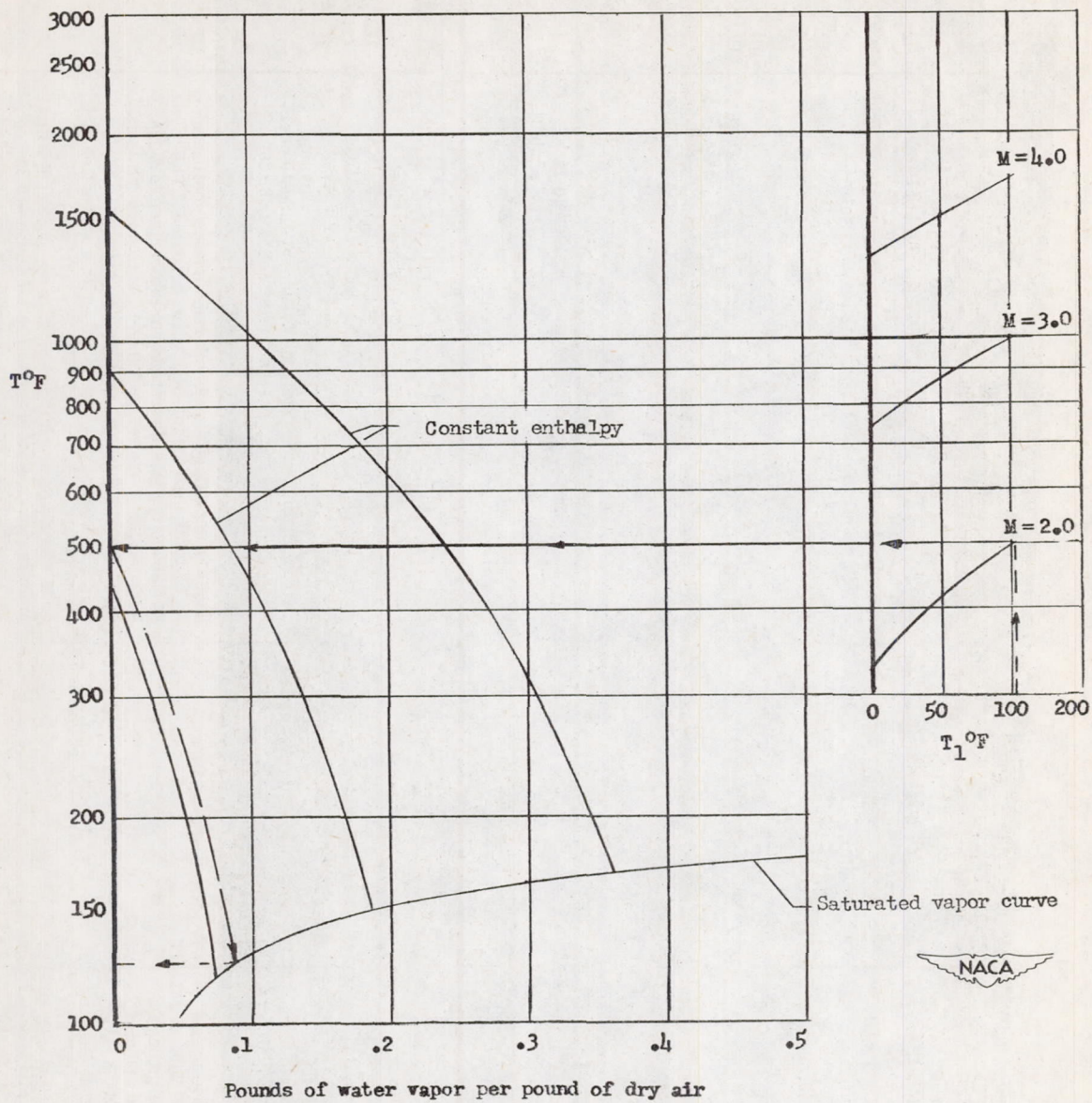

Figure 11.- Method of calculating the equilibrium skin temperature for transpiration cooling.