

931
RESTRICTED

NATIONAL ADVISORY COMMITTEE FOR AERONAUTICS

TECHNICAL NOTE

No. 931

GUIDES FOR PREVENTING BUCKLING IN AXIAL FATIGUE TESTS
OF THIN SHEET-METAL SPECIMENS

By W. C. Brueggeman and M. Mayer, Jr.
National Bureau of Standards

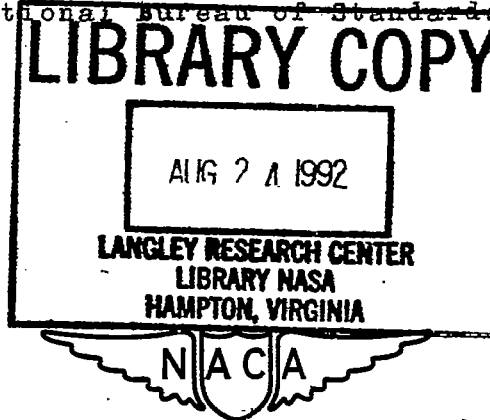

Washington
April 1944

~~CLASSIFIED DOCUMENT~~

This document contains classified information affecting the National Defense of the United States within the meaning of the Espionage Act, USC 50:31 and 32. Its transmission or the revelation of its contents in any manner to an unauthorized person is prohibited by law. Information so classified

may be imparted only to persons in the military and naval Services of the United States, appropriate civilian officers and employees of the Federal Government who have a legitimate interest therein, and to United States citizens of known loyalty and discretion who of necessity must be informed thereof.

RESTRICTED

NATIONAL ADVISORY COMMITTEE FOR AERONAUTICS

TECHNICAL NOTE NO. 931

GUIDES FOR PREVENTING BUCKLING IN AXIAL FATIGUE TESTS
OF THIN SHEET-METAL SPECIMENS

By W. C. Brueggeman and M. Mayer, Jr.

SUMMARY

Guide fixtures are described by means of which axial fatigue loads including compression may be applied to a thin sheet-metal specimen. Tests indicate that the guides prevented buckling without bypassing the load or injuring the specimen.

INTRODUCTION

In connection with investigations sponsored by the National Advisory Committee for Aeronautics it was desired to make axial fatigue tests on aluminum-alloy 24ST sheet-metal specimens 0.032 inch and 0.102 inch thick. In general, alternating loads were to be applied; that is, the load would vary sinusoidally from a maximum compressive load (minimum load) to an equal maximum tensile load (maximum load), the mean load being zero.

To attain uniformity of stress and for other practical reasons, it is necessary that the length of an axial fatigue specimen be relatively great in relation to the width, perhaps of the order of 10:1. Assuming that the minimum width is equal to that of the standard sheet-metal static tensile specimen, 0.5 inch., the dimensions of the thinnest specimen would be 0.032 by 0.5 inch by 5.0 inches. Unless this specimen is supported laterally it is not possible to apply a compressive load of the magnitude necessary for fatigue testing as buckling would occur at a lower load.

Several means for supporting sheet-metal specimens against buckling under static loads have been used (references 1 to 4). The most promising of these for fatigue loads appeared to be that used at the National Bureau of Standards by Aitchison and Miller (reference 4), which consists of restraining the specimen between stiff lubricated guides. This is an adaptation of the Montgomery fixture (reference 3), the rollers having been replaced by solid bars. Light-weight guides were developed for fatigue use employing this principle.

Before confidence could be placed in these guides it was necessary to verify that they prevented buckling without bypassing load around the specimen and without injurious effects on the specimen, such as abrasion.

Experimental evidence of the adequacy of the guides is presented in this report together with a description of the testing technique.

Machines.— Tests were made in two axial tension-compression fatigue machines. In machine A (fig. 1) the load is applied to the specimen by means of a crank-driven lever at the rate of 1000 cycles per minute; in machine B, (fig. 2) by means of an eccentric at the rate of 2000 cycles per minute. The capacity of both machines is about ± 1500 pounds.

Specimen.— Reduced-section sheet-metal fatigue specimens, as shown in figure 3 were used in both machines. The thickness was 0.032 inch for machine A and 0.102 inch for machine B.

Guides.— Guides similar to those shown in figure 4 were used in machine A to make possible strain measurements on the specimen; those shown in figure 5 were used in machine B for that purpose. For routine testing strain is not measured; the guides shown in figures 6 and 7 are used. The parts consist of A (fig. 7) the specimen; B, a pair of steel bars lightened by milling to an I-section; C, side plates which hold the bars in place; D, paper saturated with lubricant; E, bolts; F, washers; G, nuts. The special side plates H have an opening for a Tuckerman gage. The bolt holes in the side plates are elongated to permit adjustment.

The paper, D, has been found necessary to retain the lubricant. Early experiments in which the paper was not used resulted in abrasion of the specimen due to working out of the lubricant.

When assembling, a strip of the saturated paper is placed on each side of the specimen; the parts are bolted together snugly but not tightly; the bars are clamped firmly against the specimen by small C-clamps at each end; the bolts are tightened and the clamps are removed. When properly assembled, the guide may easily be slid by hand on the specimen and in a vertical machine will quickly work down on the specimen under its own weight. The guide is maintained in its medial position by placing a felt or rubber pad between the end (or ends in the case of machine B) of the guide and the grip.

Best results were obtained with a grease lubricant of a type used in ball bearings. This grease is designated Andok II-275 and is marketed by the Standard Oil Company of New Jersey. A coat of the grease is applied to both sides of the paper and is allowed to soak in until the paper is saturated.

The paper was taken from a lot produced for a special purpose in the experimental paper mill of the Bureau. It is a waterleaf sheet approximately 0.004 inch thick made from a furnish of 50 percent sulfite and 50 percent soda wood pulp. Its chemical reaction was practically neutral. This paper differs from most common commercial papers in that it is free from resin and alum; probably its consistency is more nearly that of blotting paper than of any other commercial paper. Little experience has been had with other papers. One colored paper which was tried apparently had a slight corrosive action on the aluminum-alloy specimen.

The guide bars A shown in figure 5 were used in conjunction with special wire gages mounted on the specimen. The gages consisted of a hairpin loop of resistance wire B 0.001 inch in diameter cemented to each side of the specimen. For insulation a strip of paper about 1/8 inch by 5 inches was cemented to the specimen, the wire loop was cemented to the paper, another strip of paper was cemented on top of the loop. The resistance of each gage was 90 ohms. The guide bar A is lightened by milling to a channel-shape cross-section and the face is

grooved to clear the wire gage. Grease-saturated paper was used as with the regular guides.

Tests.— Strain amplitude measurements were made for several load amplitudes on specimens in machine A under both static and dynamic conditions as follows:

1. Minimum load is 0, guides off
2. Minimum load is 0, guides on
3. Mean load is 0, guides on

For the static condition the crank of the machine was turned slowly by hand. The strain amplitude was determined by means of a pair of Tuckerman optical strain gages mounted on the edges of the specimen as shown in figure 4. The autocollimator was equipped with a dumb-bell reticule.

The amplitude of the resistance change $\frac{\Delta R}{R}$, of the wire gages was determined for the specimen which was loaded in machine B under conditions similar to those obtained for machine A. In addition a series of compressive loads (maximum load is 0) were applied.

The change in resistance of the wire gages was determined by means of an a.c. Wheatstone bridge of which a Campbell-Shackelton shielded ratio box (reference 5) formed two arms, a Kohlrausch slide wire the third, and the wire gage the fourth. The change in resistance of the gage with load modulated a 1500-cycle carrier signal applied to the bridge; the amount of the modulation was measured on the screen of a cathode-ray oscillograph. The change in resistance of the gage was determined by adjusting the Kohlrausch slide wire to produce the same change in modulation.

Results.— The results are given in figures 8 and 9 for machine A and in figures 10, 11, and 12 for machine B. In the case of machine B the relative change in resistance

$\frac{\Delta R}{R}$ was plotted as abscissa or ordinate directly without converting to strain. No significant difference is apparent between the amplitude of the strain or $\frac{\Delta R}{R}$

corresponding to a given load amplitude with the guides on and with the guides off.

It is evident in figure 9 that the strain amplitude is about 6.5 percent greater when machine A is running than when the crank is turned slowly by hand. This difference is caused by the inertia of the lever; a similar difference has been observed in another machine by others (reference 6).

Figure 11 fails to show an appreciable "dynamic overthrow" for machine B, within observational errors which were as high as 6 percent for one of the points.

There was no effect of the guides on the strain or on $\frac{\Delta R}{R}$ for static and dynamic loads. Figure 12 shows that $\frac{\Delta R}{R}$ was very nearly equal on both sides of the specimen for all types of loading with the guides on.

Experience with the guides on specimens to which as many as 10^7 cycles of stress were applied has not shown any injurious abrasion or other effects which could be correlated with premature failure of the specimen.

Conclusion.— A method is described for laterally supporting a thin sheet-metal specimen to prevent buckling when axial compressive fatigue loads are applied.

Tests in two fatigue-testing machines on laterally supported 24S-T sheet-metal specimens 0.032 inch and 0.102 inch thick have indicated an axial condition of loading and negligible bypassing of the load by the guides. No noticeable abrasion or other injurious effects have been experienced when using the technique described.

National Bureau of Standards,
Washington, D.C., January 7, 1944.

REFERENCES

1. Aitchison, C. S., and Tuckerman, L. B.: The "Pack" Method for Compressive Tests of Thin Specimens of Materials used in Thin-Wall Structures. NACA Rep. No. 649, 1939.
2. Franks, Russell, and Binder, W. O.: The Stress-Strain Characteristics of Cold Rolled Austenitic Stainless Steels in Compression as Determined by the Cylinder Test Method. Proc. ASTM, vol. 41, 1941, p. 629.
3. Paul, D. A., Howell, F. M., and Grieshaber, H. E.: Comparison of Stress-Strain Curves Obtained by the Single-Thickness and Pack Methods. NACA TN No. 819, 1941.
4. Anon.: Compressive Tests of Sheet Metal with Solid Guides for Lateral Support. Struc. Memo, No. 10, Bur. Aero., Navy Dept., Nov. 10, 1942.
5. Behr, L. and Williams, A. J., Jr.: The Campbell-Shackelton Shielded Ratio Box. Proc. Inst. Radio Eng., vol. 20, 1932, p. 969.
6. Russell, H. W., Jackson, L. R., Grover, H. J., and Beaver, W. W.: Fatigue Characteristics of Spot-Welded 24S-T Aluminum Alloy. NACA ARR No. 3F16, 1943.

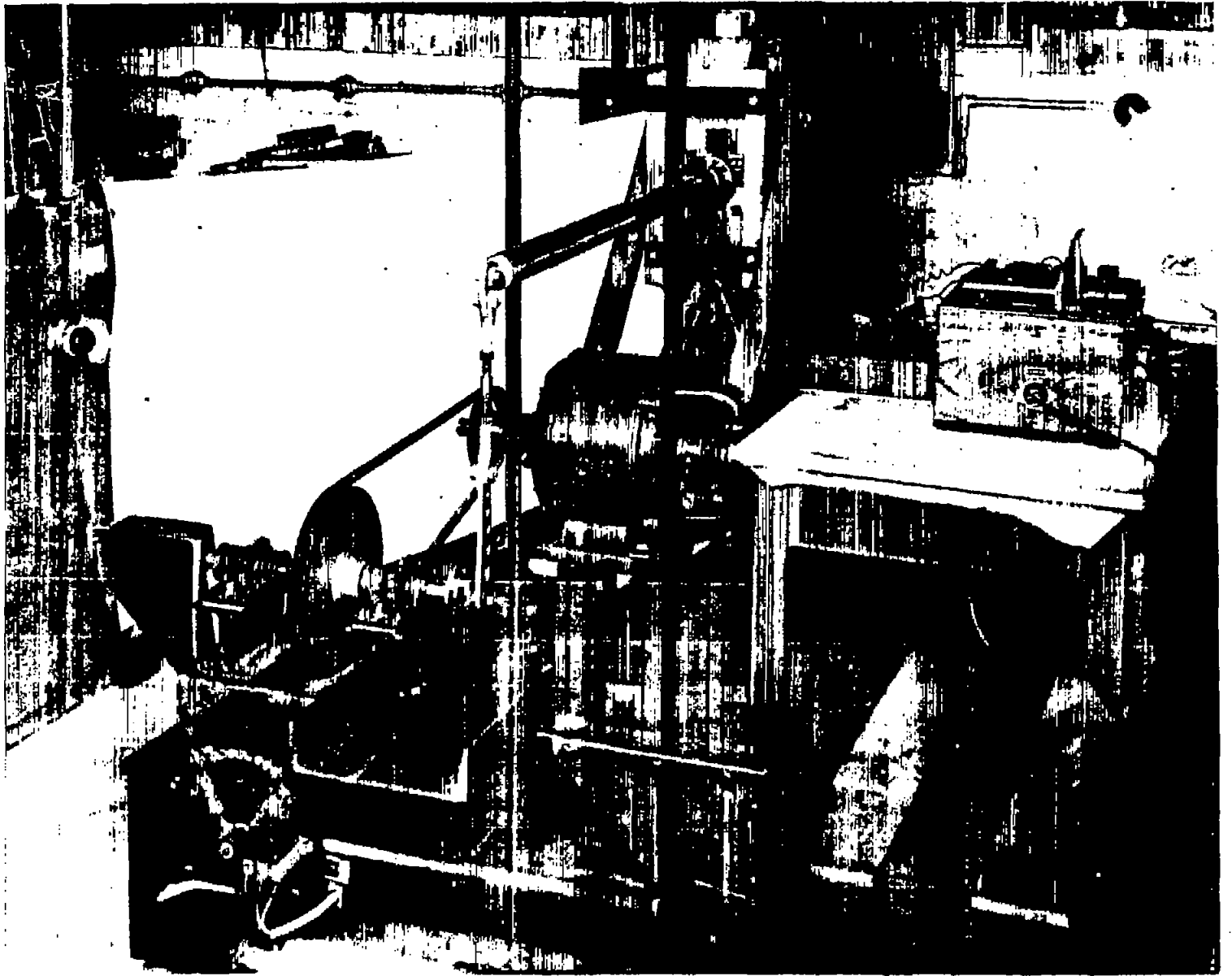

FIG. 1

Figure 1.- Fatigue testing machine A.

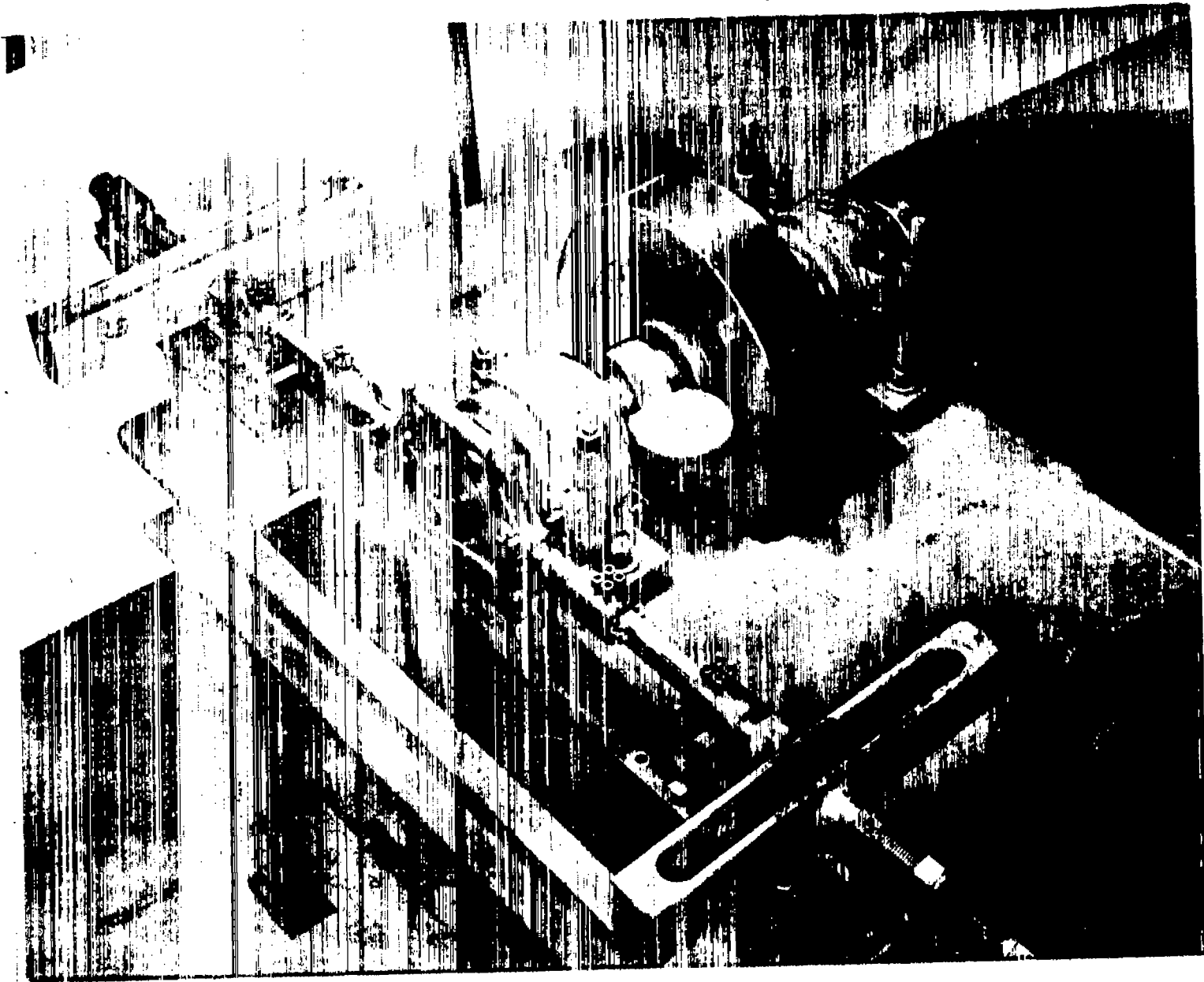

FIG. 2

Figure 2.- Fatigue testing machine B.

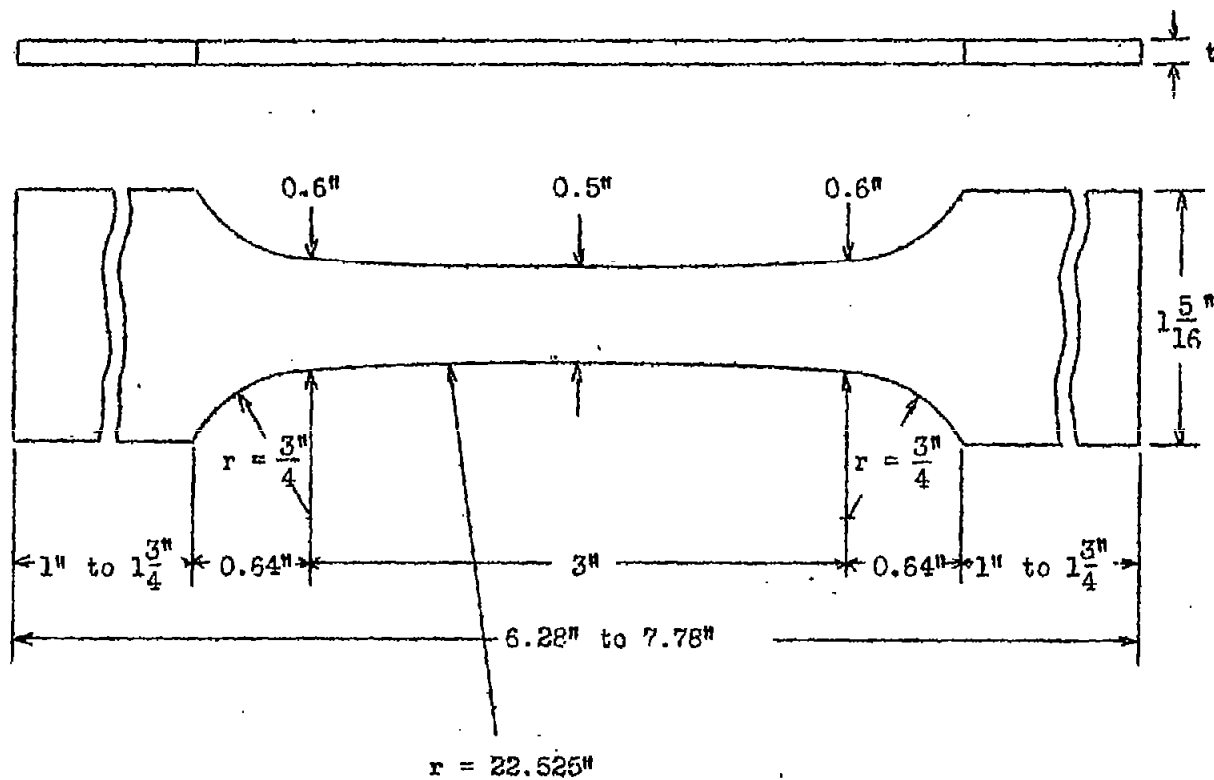

Figure 3.- Sheet metal fatigue specimen.

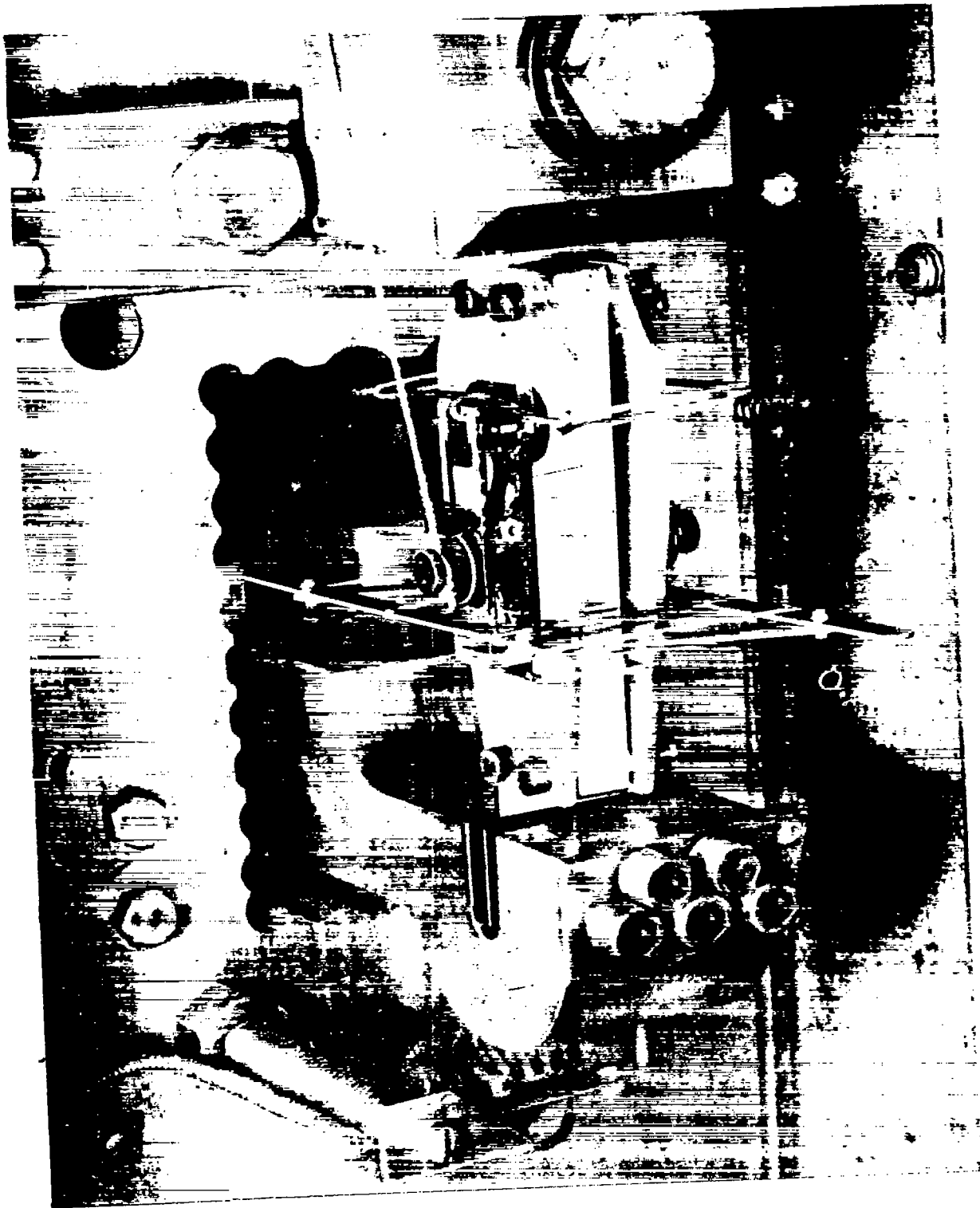

Figure 4.- Apparatus for measuring the strain on the edges of a guided fatigue specimen.

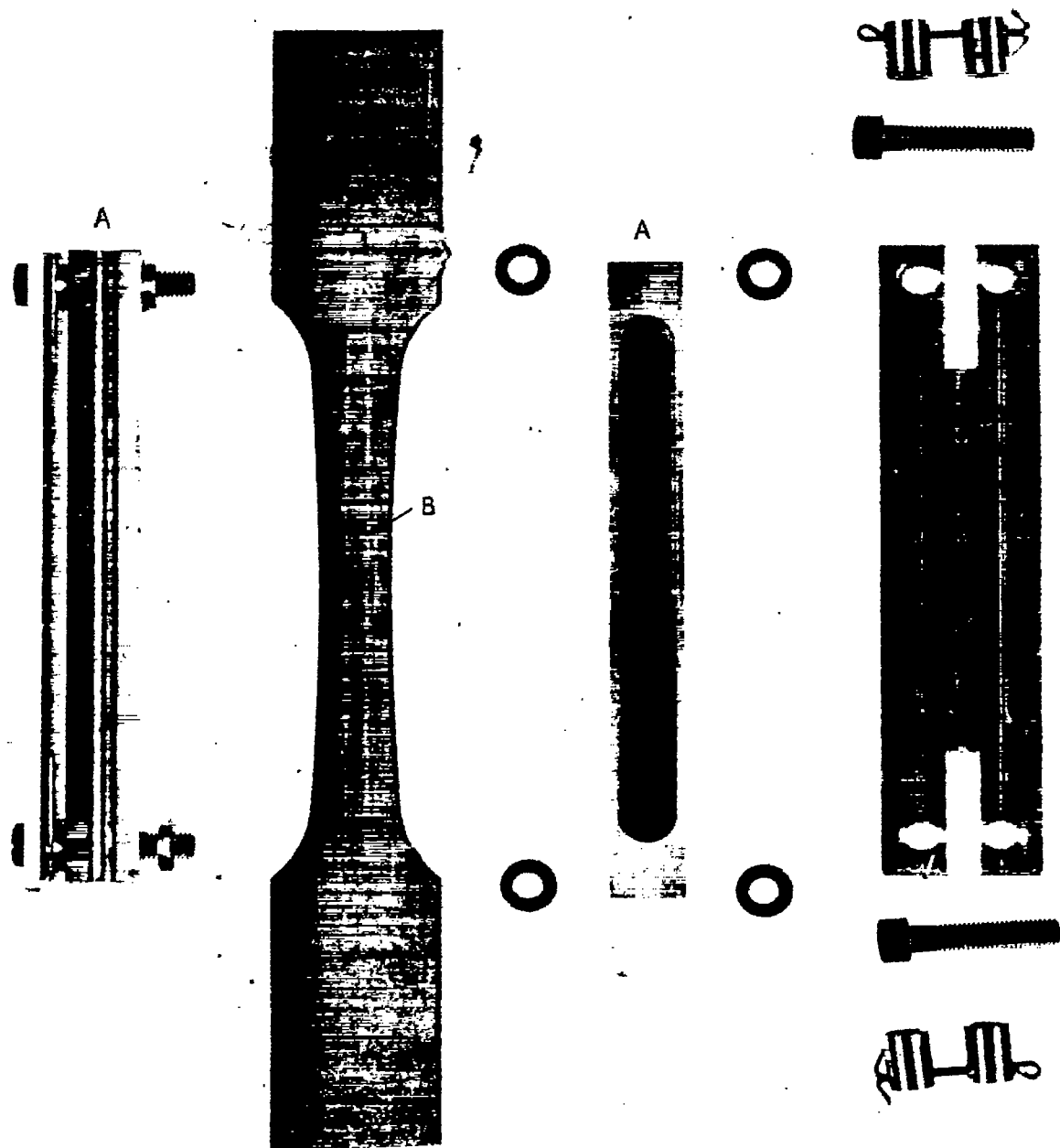

Figure 5.- Special wire gage mounted on a fatigue specimen and guide for this specimen.

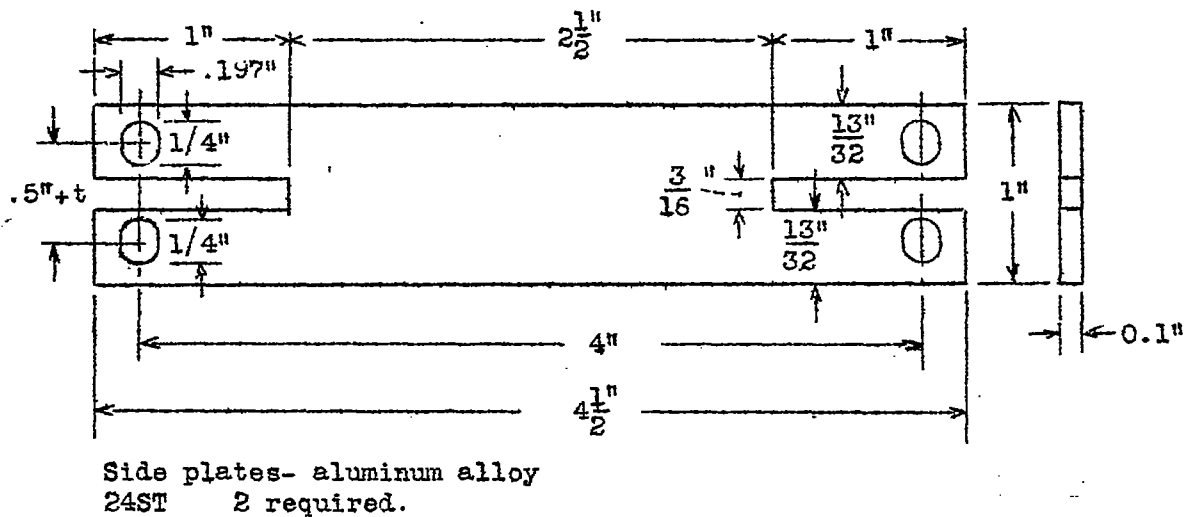
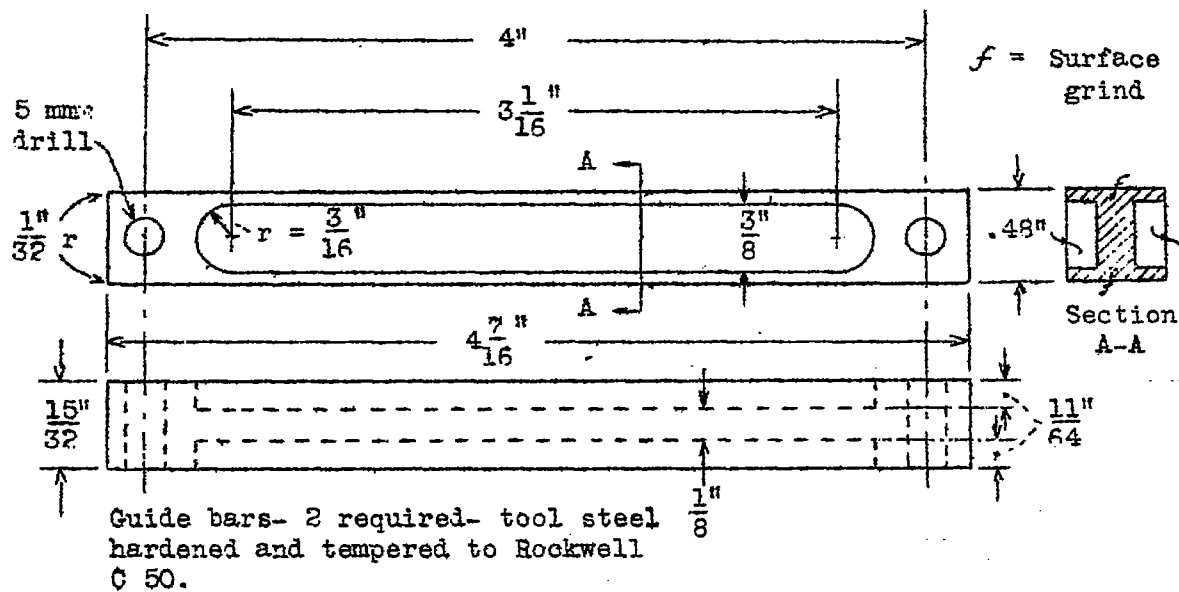

Figure 6.- Lateral guide fixture.

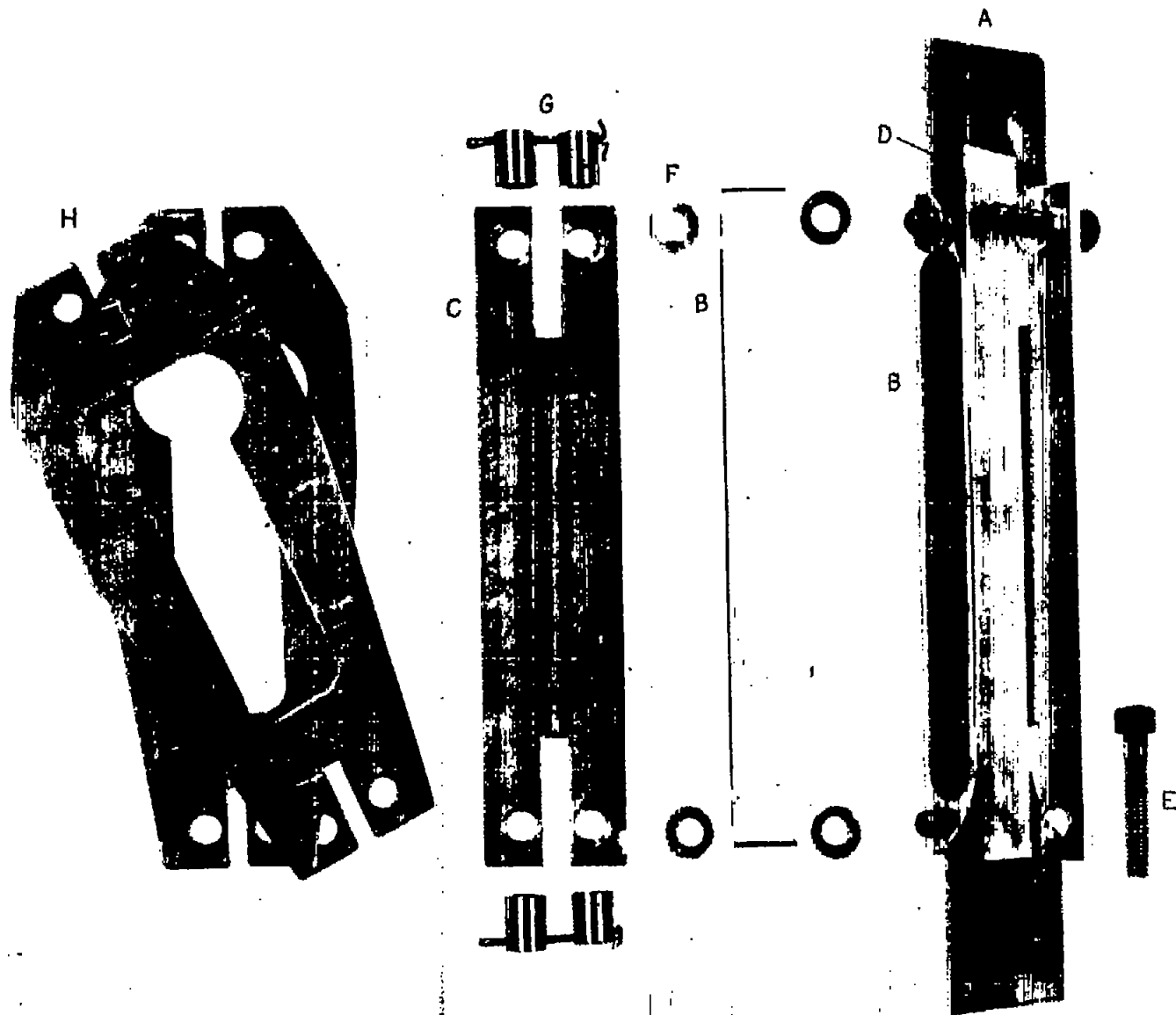

Figure 7.- Parts of guide assembly.

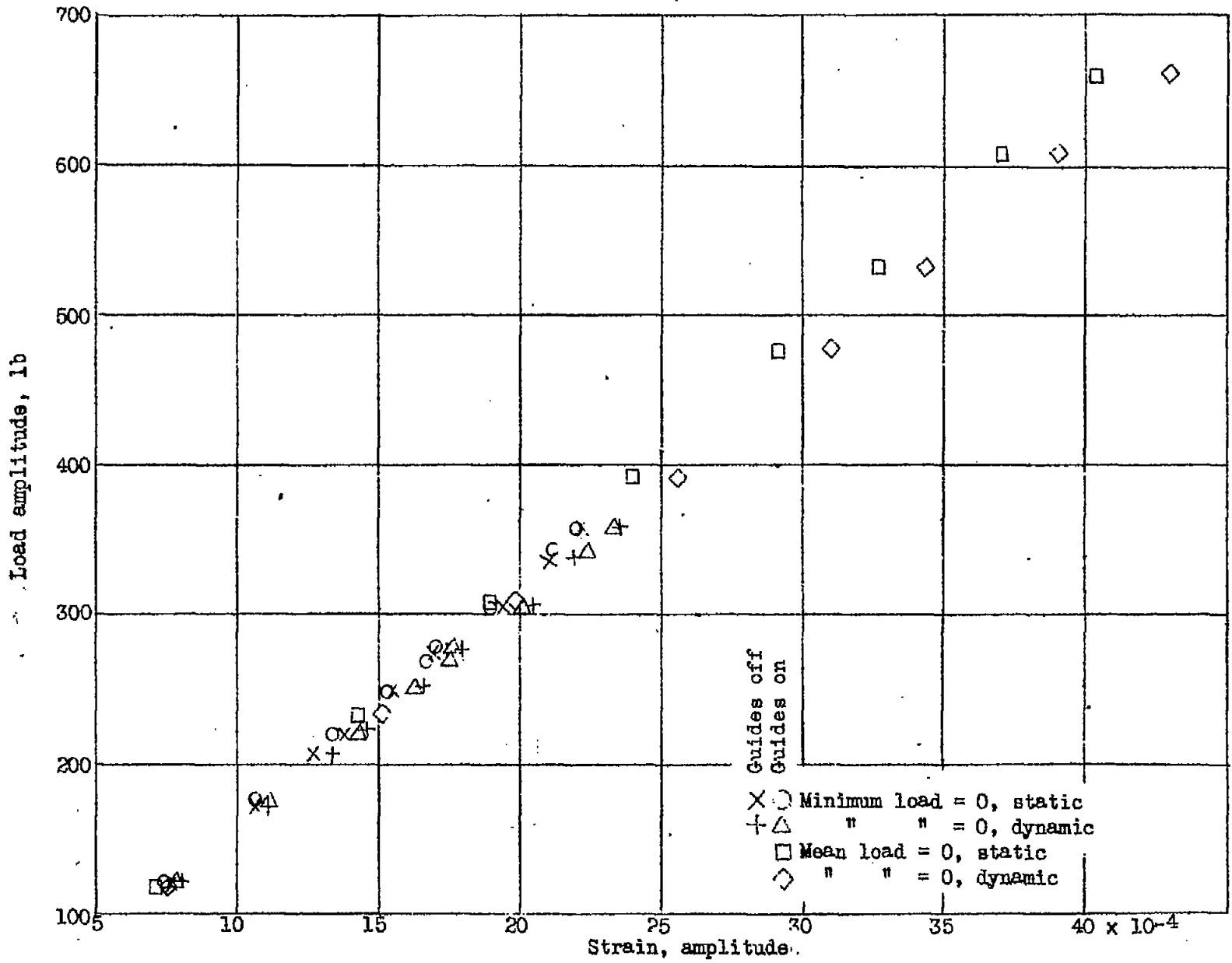

Figure 8.- Results for machine A.

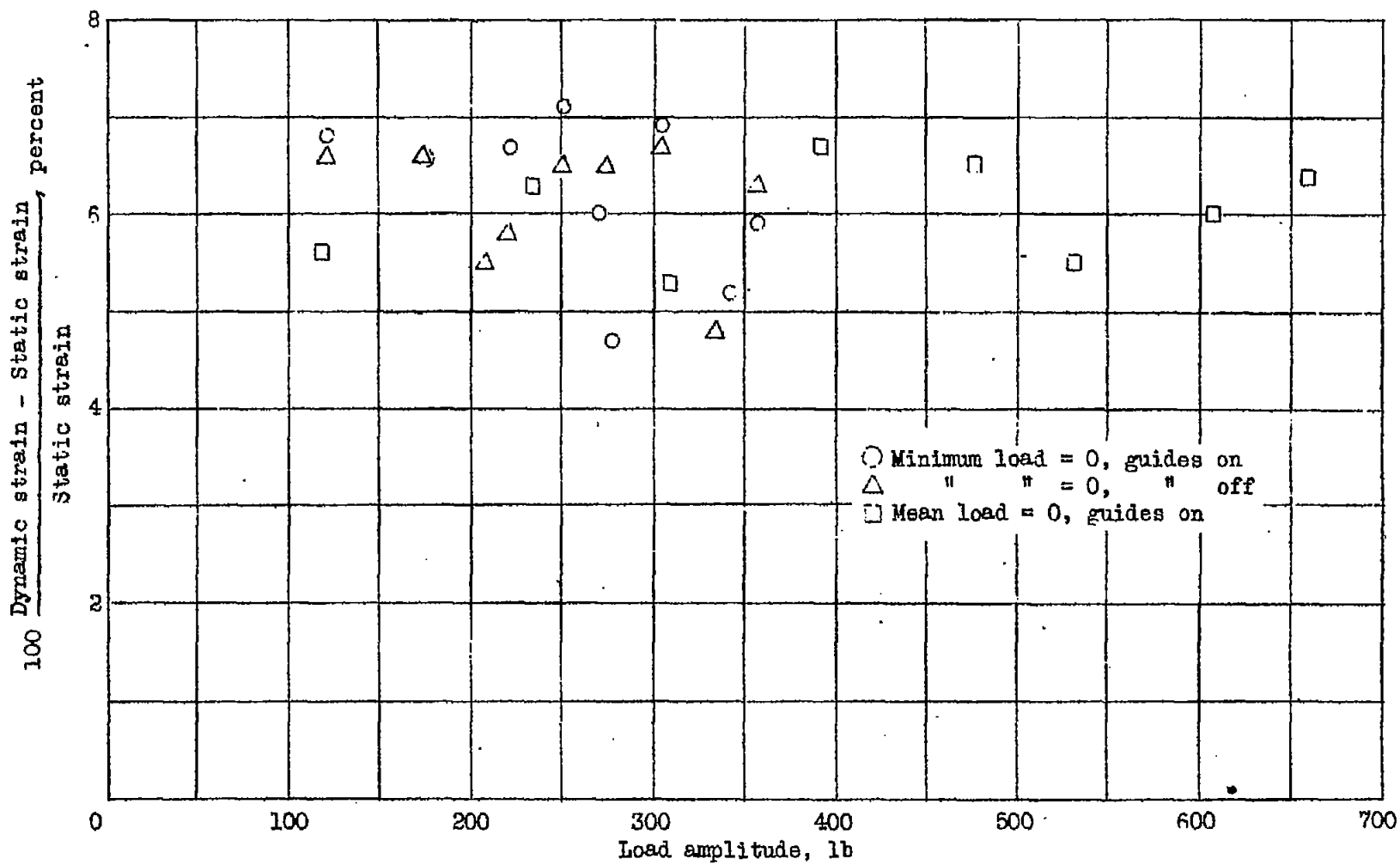

Figure 9.- Dynamic overthrow for machine A.

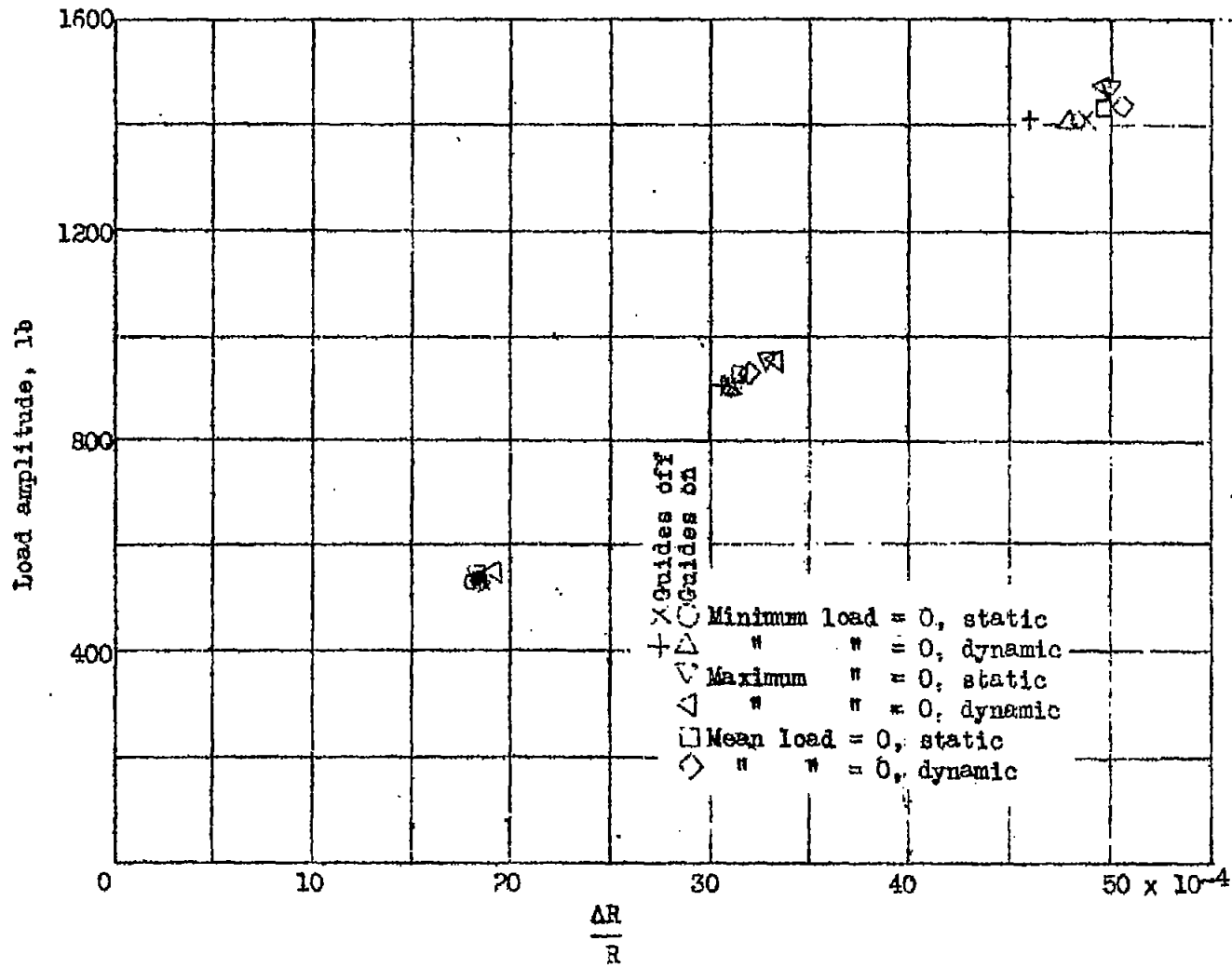

Figure 10.- Results for machine B.

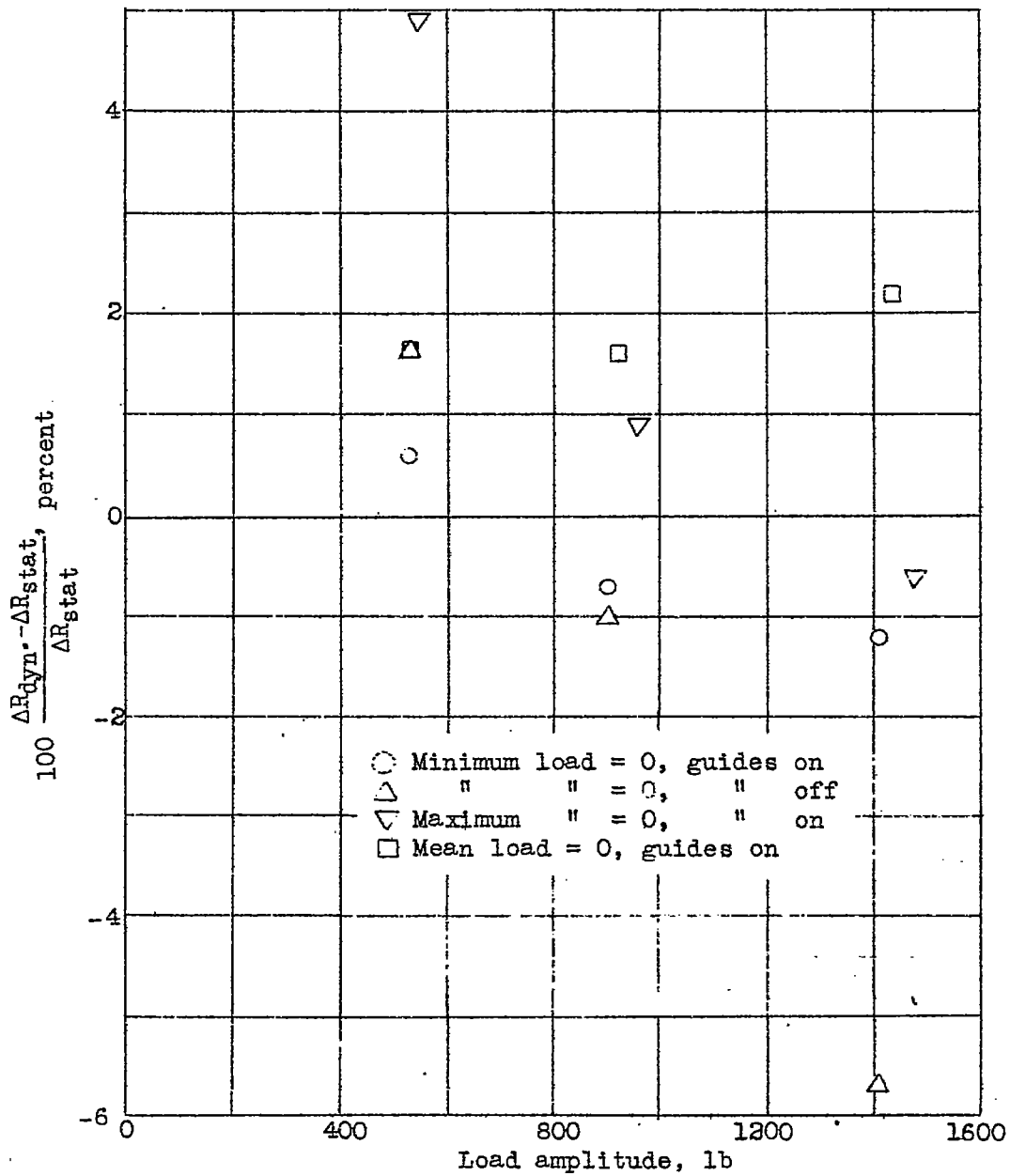

Figure 11.- Dynamic overthrow of machine B.

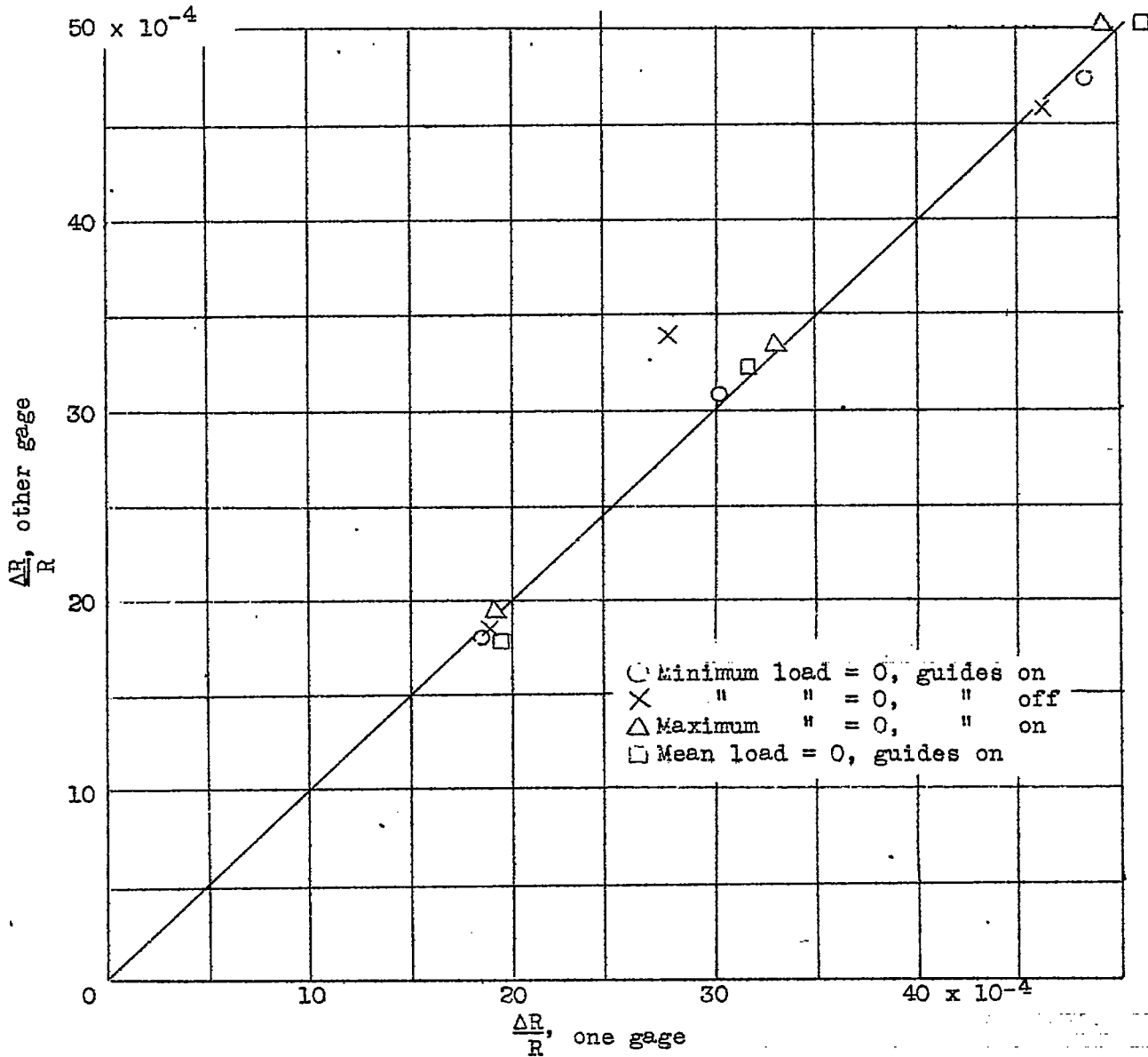

Figure 12.- Equality of $\Delta R/R$ for both sides of the specimen (machine B).