

CONFIDENTIAL

Copy 385
RM E53L22b



**CASE FILE
COPY**

RESEARCH MEMORANDUM

EVALUATION OF A COMPRESSOR BLEED SYSTEM FOR RIM COOLING
THE TURBINE WHEEL OF A TURBOJET ENGINE

By C. R. Morse and R. H. Kemp

Lewis Flight Propulsion Laboratory
Cleveland, Ohio

CLASSIFICATION CHANGED TO UNCLASSIFIED
AUTHORITY: NASA PUBLICATION ANNOUNCEMENT NO. 4
EFFECTIVE DATE: FEBRUARY 10, 1959
WHL

CLASSIFIED DOCUMENT

This material contains information affecting the National Defense of the United States within the meaning of the espionage laws, Title 18, U.S.C., Secs. 793 and 794, the transmission or revelation of which in any manner to an unauthorized person is prohibited by law.

NATIONAL ADVISORY COMMITTEE FOR AERONAUTICS

WASHINGTON

March 22, 1954

CONFIDENTIAL

NACA RM E53L22b

NATIONAL ADVISORY COMMITTEE FOR AERONAUTICS

RESEARCH MEMORANDUM

EVALUATION OF A COMPRESSOR BLEED SYSTEM FOR RIM COOLING

THE TURBINE WHEEL OF A TURBOJET ENGINE

By C. R. Morse and R. H. Kemp

SUMMARY

A system of cooling the rim of a turbine wheel by means of compressor-discharge air was designed and evaluated in a J33-A-33 turbojet engine. The cooling air was directed at the wheel rim by means of two annular orifices, one on each side of the wheel. At a minimum cooling air flow of 0.25 percent of the engine air flow, the wheel rim temperatures were 885°, 940°, and 925° F at the front, center, and rear thermocouple locations, respectively. At a maximum cooling air flow of 1.4 percent of the engine air flow, the corresponding temperatures were 670°, 840°, and 795° F. Calculations based on the shear stress-rupture strength of the wheel serrations indicated that certain ferritic alloys could be used for the wheel under military rated operating conditions by cooling with approximately 0.8 percent of the engine air flow by means of compressor-discharge air.

INTRODUCTION

Cooling of the rim of conventional turbojet turbine wheels has several advantages. The reduced wheel temperatures permit substitution of other materials for at least part of the strategic elements used. Also, materials such as cermets having high thermal conductivities relative to conventional blade alloys can be used for the turbine blades without resulting in overheating of the wheel rim. Finally, higher turbine-inlet gas temperatures can be employed without increasing the wheel temperatures.

An investigation was therefore undertaken at the NACA Lewis laboratory with the objectives of designing and evaluating a wheel rim cooling system utilizing compressor-discharge air as the cooling medium. A J33-A-33 turbojet engine was used; the results, however, can be applied to most turbojet engines. The quantities of cooling air applied to the various portions of the turbine wheel rim were varied over a wide range and the effect on the turbine wheel temperatures was determined by means of 12 thermocouples at various locations on the wheel.

The design and operating characteristics are presented for a wheel rim cooling system using compressor-discharge air, and the quantity of cooling air required to permit certain wheel material substitutions is indicated.

APPARATUS AND PROCEDURE

A J33-A-33 turbojet engine was modified and instrumented to determine the amount of turbine wheel rim cooling that could be obtained with moderate amounts of cooling air provided by means of compressor-discharge bleedoff. Figure 1 shows the manner in which air was drawn from the compressor diffuser section through small flexible hoses to a collector tank. Identical orifice runs with individual remotely controlled valves were employed to distribute the cooling air from this tank to the front and rear faces of the turbine wheel through manifolds. The cooling air was directed against the wheel surface from annular orifices formed by sheet metal baffles at a point $1\frac{1}{2}$ inches radially inward from the rim. The spacing of the lips of the annular orifices was approximately 0.040 inch; the diameter of the annulus was 15 inches.

A third orifice and a remotely controlled valve assembly were provided in order to control and measure the amount of front-face cooling air which was bled off at the annular orifice formed by the outer edge of the special baffle assembly and the inner ring of the nozzle diaphragm. Air passing through this orifice assembly was discharged into the test cell.

The temperature and the static pressure of the cooling air were measured, respectively, by thermocouples and pressure-probe tubes located at several points in the cooling-air passages, as shown in figure 2.

Turbine wheel metal temperatures were measured by 12 thermocouples installed in the bottoms of holes drilled from the rear face of the wheel at locations shown in figure 3. Five holes were drilled to points $1/8$ inch from the front face of the wheel at wheel radii of 6.00, 7.50, 8.02, 8.43, and 8.85 inches; three holes were drilled to midwheel thickness at wheel radii of 8.02, 8.42, and 8.85 inches; and four holes were drilled $1/8$ inch deep at wheel radii of 6.00, 7.50, 8.02, and 8.43 inches on the rear face.

A thermocouple was installed firmly against the bottom of each of these holes, and the lead wires were led radially to the wheel hub and thence carried through drilled passages in the turbine shaft and compressor shaft to a slip-ring assembly mounted on the accessory case of the engine. The lead wires on the rear face of the turbine wheel were run through small stainless steel conduits which were fastened to the

wheel by stainless steel straps spot-welded along both edges. Temperature readings were indicated on a recording potentiometer.

Engine air flow was measured by an orifice run which admitted air to the sealed test cell. Thrust measurement was by means of an air pressure-balanced diaphragm. Fuel flow was measured by a rotameter-type flowmeter. Engine speed was measured by a chronometric tachometer. The engine was equipped with an adjustable jet nozzle by means of which tail-pipe gas temperature was regulated.

The tail-pipe gas temperature was measured by averaging the readings of 14 thermocouples equally spaced around the tail pipe at station 2 in figure 1.

All data were taken with the engine operating at an indicated rotor speed of 11,750 rpm and an indicated tail-pipe gas temperature average of 1275° F as measured at station 2 in figure 1.

The cooling air flow was varied within the limits of the configuration used, the minimum cooling-air-flow conditions being determined by the limit of safe turbine bearing temperature, and the maximum air flow being limited by the pressure drop in the system with the regulating valves in maximum open position. At each point the turbine wheel temperatures were allowed to reach equilibrium.

RESULTS AND DISCUSSION

Effect of Cooling Air on Wheel Temperatures

An engine was modified as shown in figure 1. A series of runs was made with various rates of cooling air flow in the range from 0.25 percent to 1.4 percent of engine air flow with one half of the total flow directed on each face of the turbine wheel at a point $\frac{1}{2}$ inches from the rim. The results of this series of runs are shown in figure 4.

Wheel rim temperatures were not materially reduced until an equally divided cooling air flow of approximately 0.5 pound per second (0.6 percent of engine air flow) was reached. At this point the rear-face rim temperature was 875° F, the center of the rim was 925° F, and the front-face rim was 860° F.

An increase of cooling air flow to 1 percent of the engine air flow resulted in a substantial reduction in temperature of all parts of the wheel with temperatures near the rim of 735°, 870°, and 790° F at the front, center, and rear, respectively. The wheel temperature profile measured in this run is shown in figure 5.

Increasing the cooling air flow to 1.06 pounds per second (1.25 percent of engine air flow) resulted in temperatures of 685°, 835°, and 740° F at the front, center, and rear of the turbine wheel rim, respectively.

Runs were made at cooling air flows of 1 percent and 1.3 percent of engine air flow, both with and without bleed of part of the front-face cooling air. At both flow rates, the wheel temperatures were higher when the bleed line was drawing off the cooling air at the wheel rim. This indicates the desirability of allowing the front-face cooling air to spill back over the wheel rim between the bases of the turbine blades.

A curve of cooling air temperature against total cooling air flow is shown in figure 6. It can be seen that part of the effectiveness of increased cooling air flow is offset by a corresponding increase in air temperature resulting from the reduced expansion of the air through regulating valves and the lower heat losses per pound accompanying the higher air velocity in the piping.

Upon completion of the mentioned runs with equal cooling air on each face of the wheel, two runs were made with varied distribution of the cooling air. In one of these runs, 0.3 percent of engine air flow was admitted to the front wheel face and 0.9 percent to the rear face. In the other run 0.8 percent of engine air flow was used to cool the front face and 0.3 percent to cool the rear face.

In the run with the greater part of the cooling air directed against the rear face of the turbine wheel the rear rim temperature was held to 855° F and the front rim ran slightly cooler, but the wheel material in the center of the rim between blade bases reached an operating temperature of 920° F. With 0.8 percent of the engine air flow on the front face of the wheel and 0.3 percent on the rear face, the same 855° F rear rim temperature was maintained while the front rim metal ran at a temperature of 700° F and the center of the rim was operating at 835° F. The maximum wheel material temperature was 65° F lower with the major part of the cooling air directed to the front rim of the wheel. Results of these runs are shown in figure 7.

In the range of cooling air flow used in this investigation no noticeable trend in the engine performance as influenced by the compressor bleed was detected within the accuracy of the instrumentation.

At the conclusion of the cooling tests described previously, the turbine wheel was removed and installed in a standard J33-A-33 engine in order to determine the operating temperature at rated speed and gas temperature. The engine was operated at 11,750 rpm and 1275° F tail-pipe gas temperature. A run was made of 1-hour duration at rated speed

and gas temperature. The wheel rim temperatures measured in this run were 830°, 935°, and 970° F at front, middle, and rear positions, respectively. Figure 8(a) shows the wheel temperature profiles obtained in this run.

Previous data for a J33-9 engine (ref. 1) show maximum turbine wheel rim temperatures of 1140° and 1190° F for front and rear wheel faces, respectively, measured 8.66 inches from the center of the wheel. The duration of the runs from which these data were obtained was a maximum of 30 minutes at rated conditions, and wheel temperatures had not reached equilibrium by the end of the run. Figure 8(b) was prepared from the data presented in reference 1 and shows the turbine wheel temperature profile after 30 minutes at rated speed and temperature.

Figure 8(c) shows a comparison plot of the wheel temperatures obtained in the rim-cooled J33-A-33 engine utilizing 1 percent of engine air flow for wheel cooling compared with the wheel temperature measured in the standard J33-A-33 engine and J33-9 engine (ref. 1) configurations.

Effect of Reduced Wheel Temperatures on Material Requirements

To determine the effect of reduced wheel temperatures on material requirements, a plot was made (fig. 9) of maximum wheel temperature (center of rim) against cooling air flow. Within the temperature range thus determined, allowable shear stress curves for the wheel serrations were determined for several materials based on 1000-hour stress-rupture data; 1000-hour shear stress-rupture strength was taken as 0.6 of 1000-hour tensile stress-rupture strength. The materials chosen for this study were: 17-22-A(S), Crucible 422, SAE 4340, and Timken 16-25-6 (the material used in the standard J33-A-33 wheel). From the curves thus obtained, minimum rim widths were calculated for each of these materials over the range of temperatures of figure 9. The results of these calculations are plotted in figure 10.

To obtain the required rim width for each material, the following assumptions were made: (a) the total load on the wheel serrations in shear is 29,800 pounds for each blade position (b) the shear area per root is 1.830 square inches, and (c) the length of root or rim width of the standard wheel is 1.960 inches. Thus the shear area per inch of rim width is 0.934 square inches per blade root.

The allowable shear load per inch of rim width for the listed alloys was obtained by multiplying published shear strength values by 0.934. Dividing the total load on the root serrations in shear (29,800 lb) by the allowable shear load per inch of rim width then gave a minimum allowable rim width for the material at a given operating temperature. The temperatures considered were within the range found to be practicable as shown in figure 9.

Figure 10 is a plot of minimum wheel-rim width based on 1000-hour shear stress-rupture strength against cooling air flow in percent of engine air flow as correlated with maximum wheel-rim temperature. It will be seen that Timken 16-25-6, which is the material in the standard wheel, has the lowest minimum rim width of the represented materials in the range below 0.38 percent cooling air. This corresponds to the temperature range above 950° F as shown on figure 9.

Increasing cooling air flow to above 0.38 percent of the engine air flow brings the required rim width for Timken 17-22A(S) within a usable range. At cooling air flows above 0.73 percent, both 17-22A(S) and Crucible 422 are usable as the maximum wheel rim temperature drops below 900° F.

Thus it is shown that the application of small quantities of cooling air to the rim of the turbine wheel would make it possible to substitute less-strategic alloys for the present wheel material.

SUMMARY OF RESULTS

The following results were obtained in an investigation of rim cooling of a turbine wheel by means of compressor-discharge air:

1. At a minimum cooling air flow of 0.25 percent of the engine air flow, the turbine wheel rim temperatures were 885°, 940°, and 925° F at front, center, and rear thermocouples, respectively; at a maximum cooling air flow of 1.4 percent of engine air flow, temperatures at the same thermocouple stations were 670°, 840°, and 795° F, respectively.
2. The most effective cooling was obtained from cooling air directed against the forward face of the turbine wheel.
3. Wheel rim temperatures were further reduced when the cooling air was allowed to flow rearward over the rim between the turbine blade bases rather than being drawn off at the periphery for discharge.
4. Calculations of minimum turbine wheel rim widths for the J33-A-33 engine, based on the shear stress-rupture strengths of the wheel serrations, indicated that ferritic alloys such as 17-22-A(S) and Crucible 422 could be substituted for the currently used austenitic

material by cooling the wheel with 0.8 percent of the engine air flow by means of compressor-discharge air.

Lewis Flight Propulsion Laboratory
National Advisory Committee for Aeronautics
Cleveland, Ohio, December 29, 1953

REFERENCE

1. Farmer, J. Elmo, Millenson, M. B., and Manson, S. S.: Study of Stress States in Gas-Turbine Disk as Determined from Measured Operating-Temperature Distributions. NACA RM E8C16, 1948.

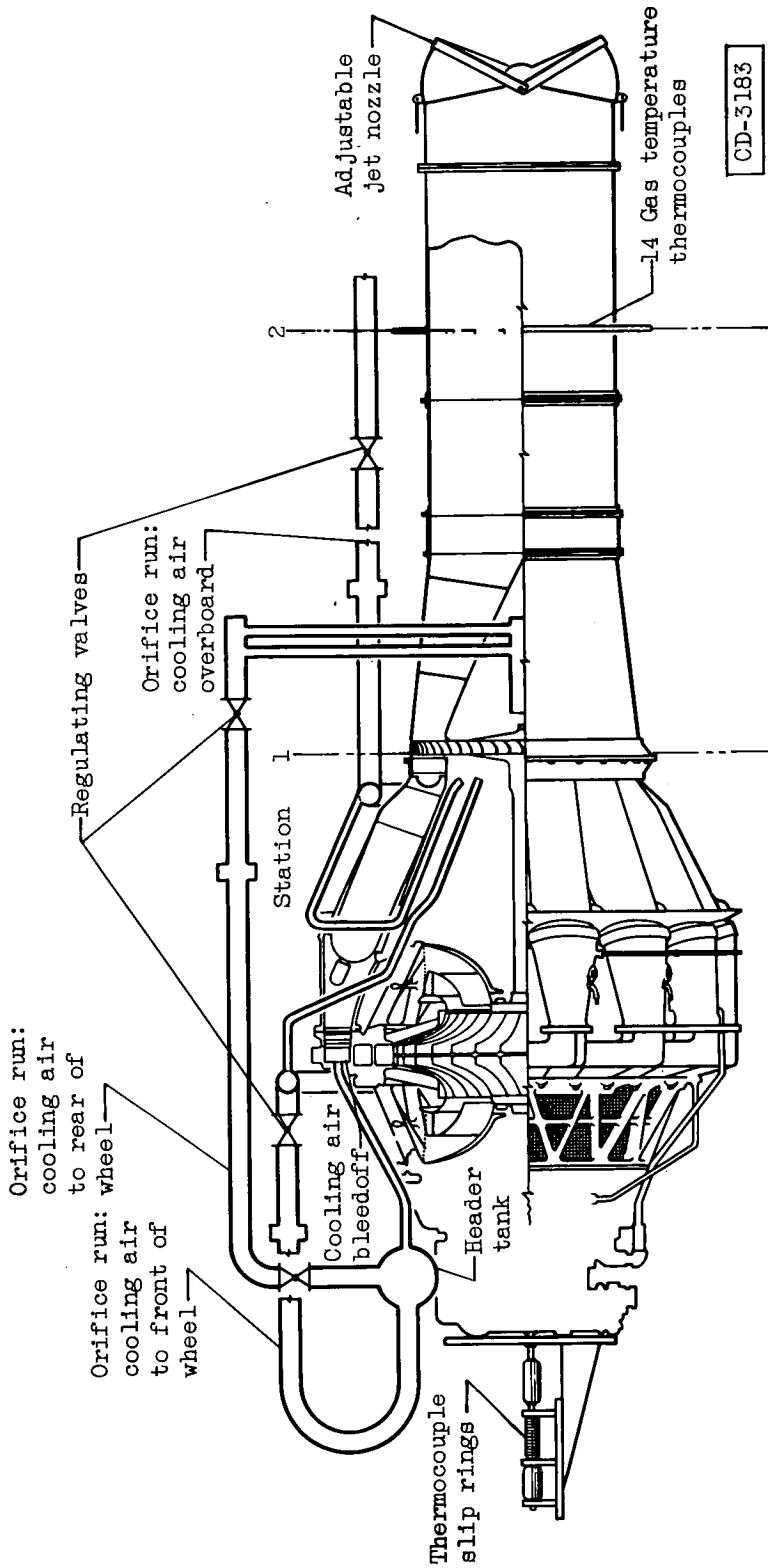

Figure 1. - Schematic diagram of cooling air piping.

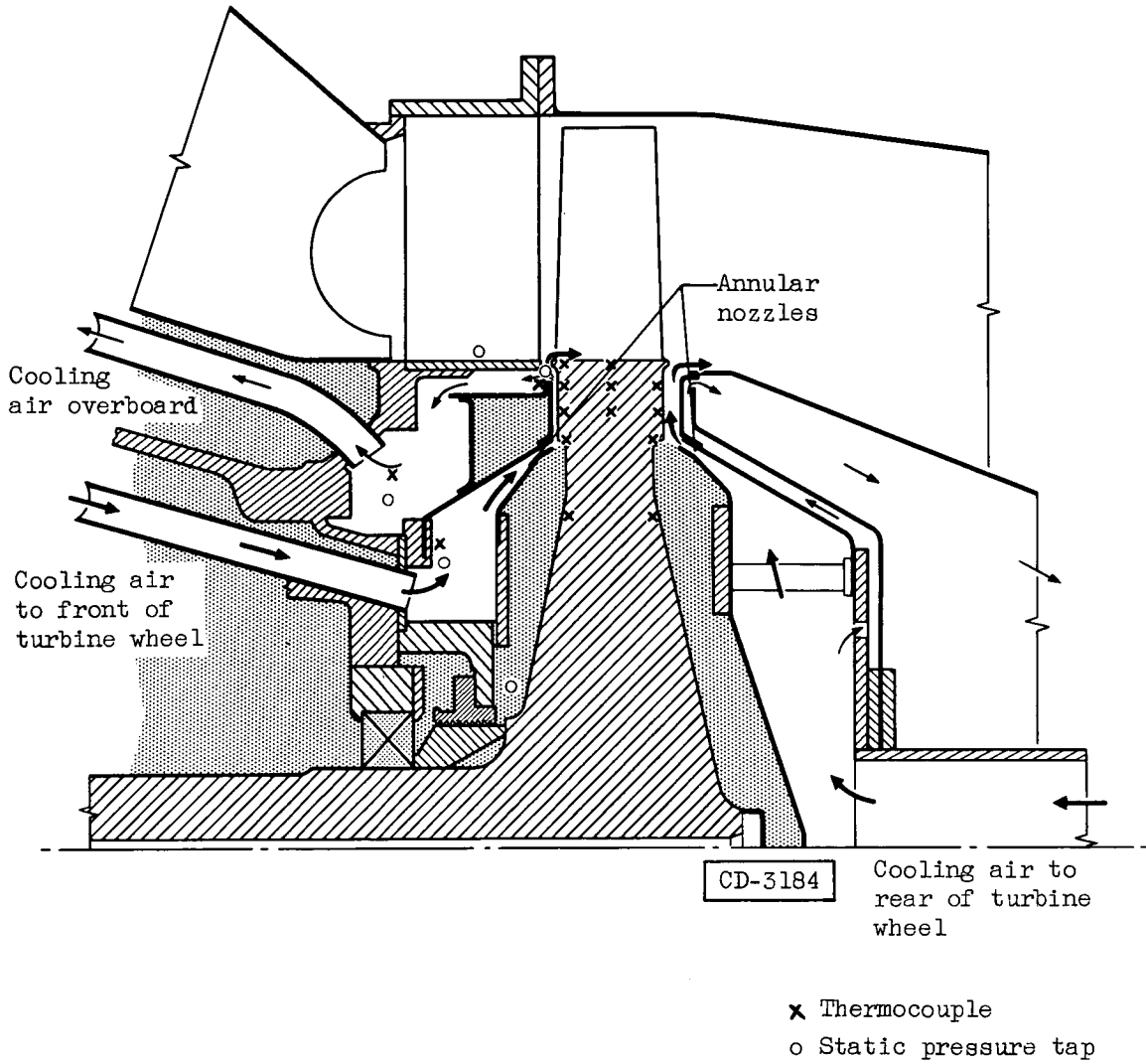

Figure 2. - Section showing turbine wheel and cooling air passages.

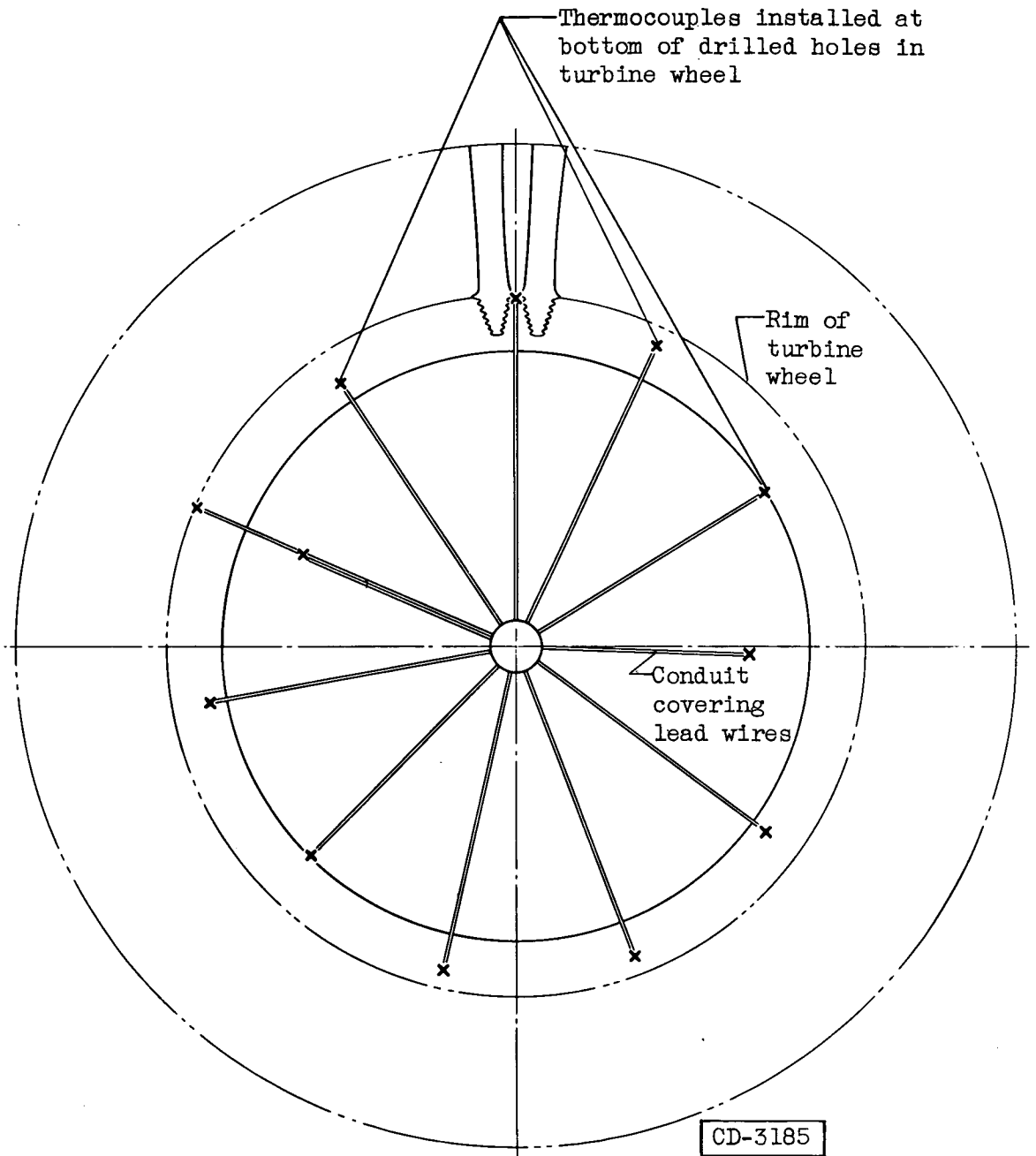
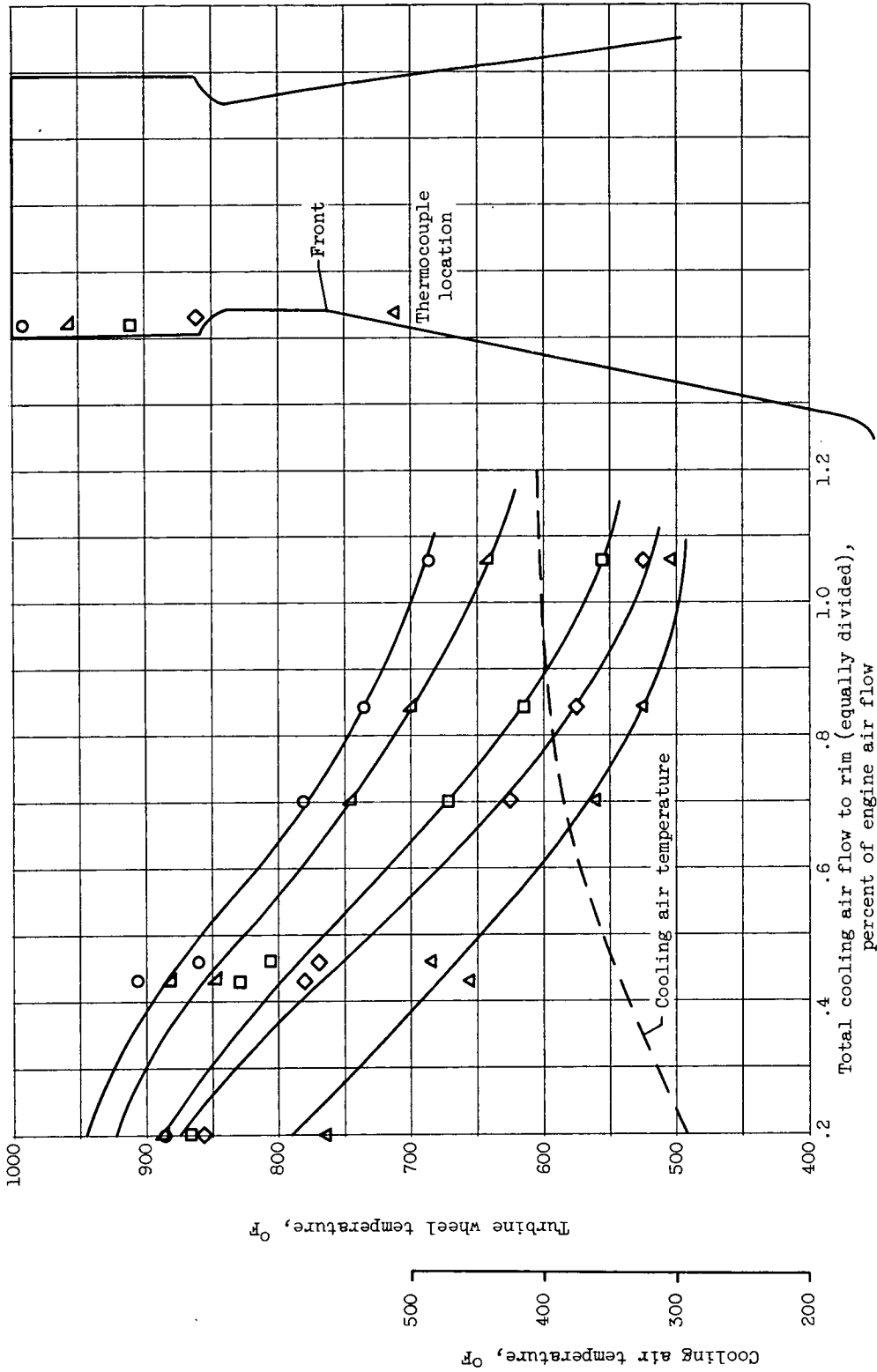
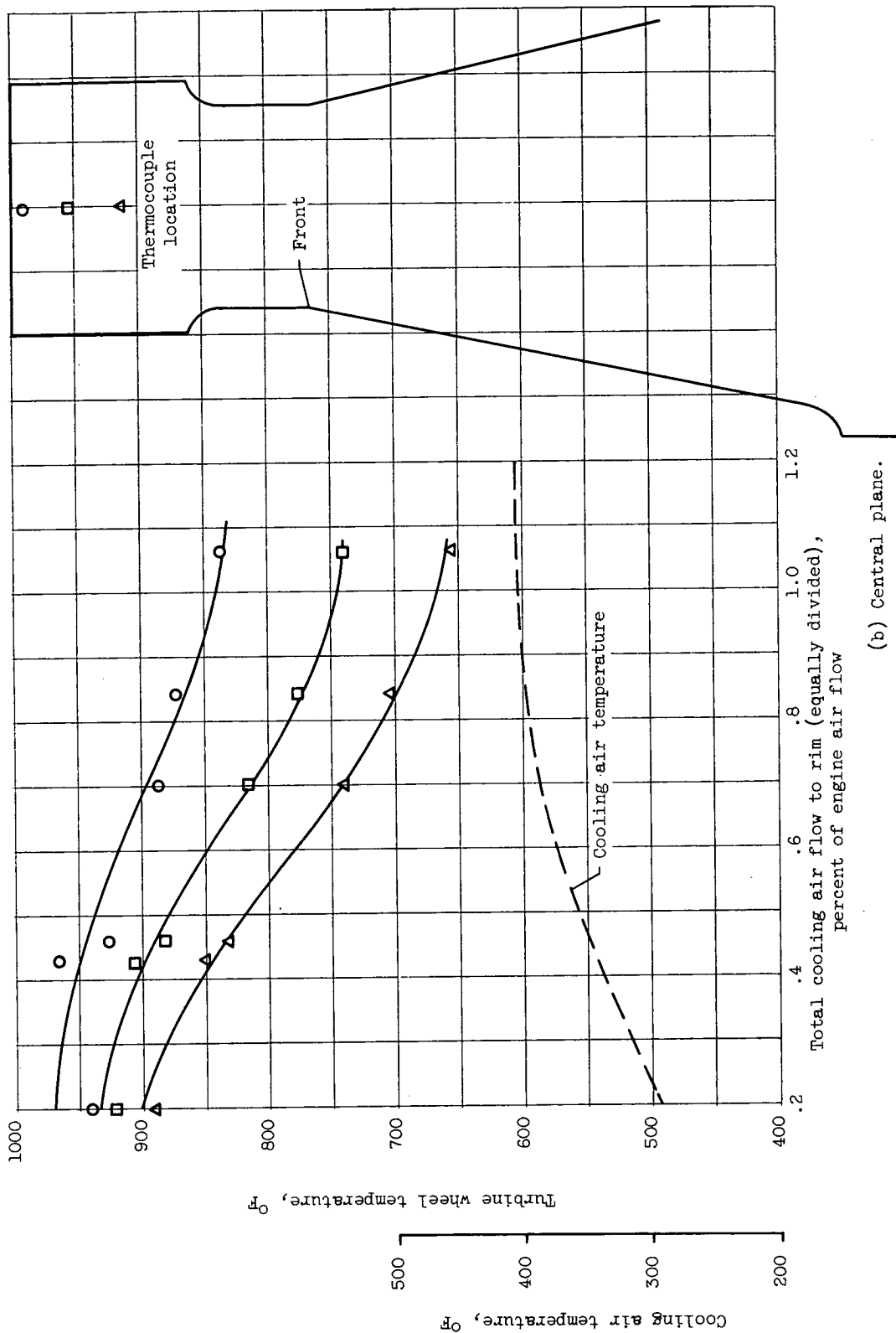

Figure 3. - Instrumentation of rear face of turbine wheel.



(a) Front face.

Figure 4. - Variation of turbine wheel temperatures with cooling air flow.



(b) Central plane.

Figure 4. - Continued. Variation of turbine wheel temperatures with cooling air flow.

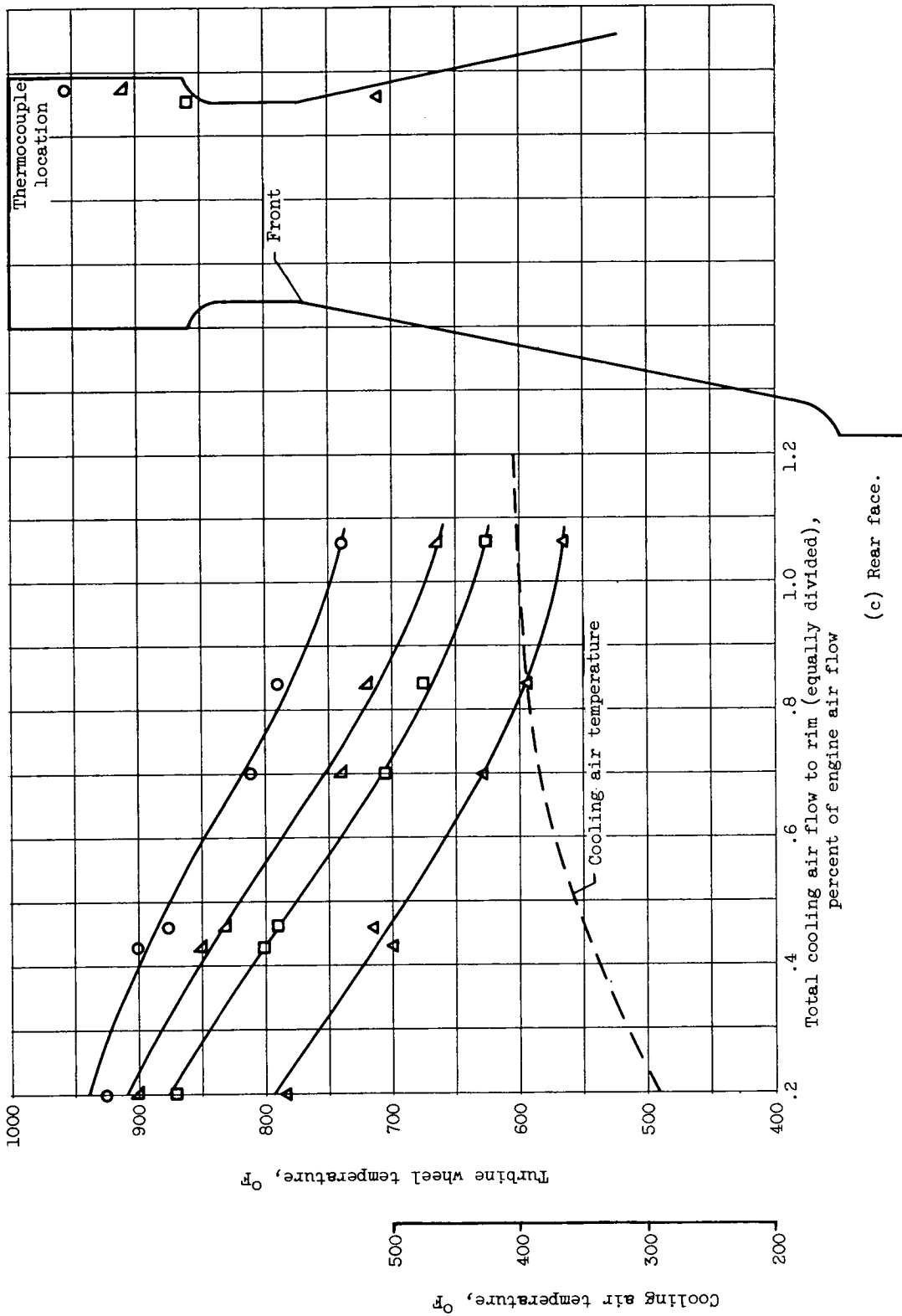

Figure 4. - Concluded. Variation of turbine wheel temperatures with cooling air flow.

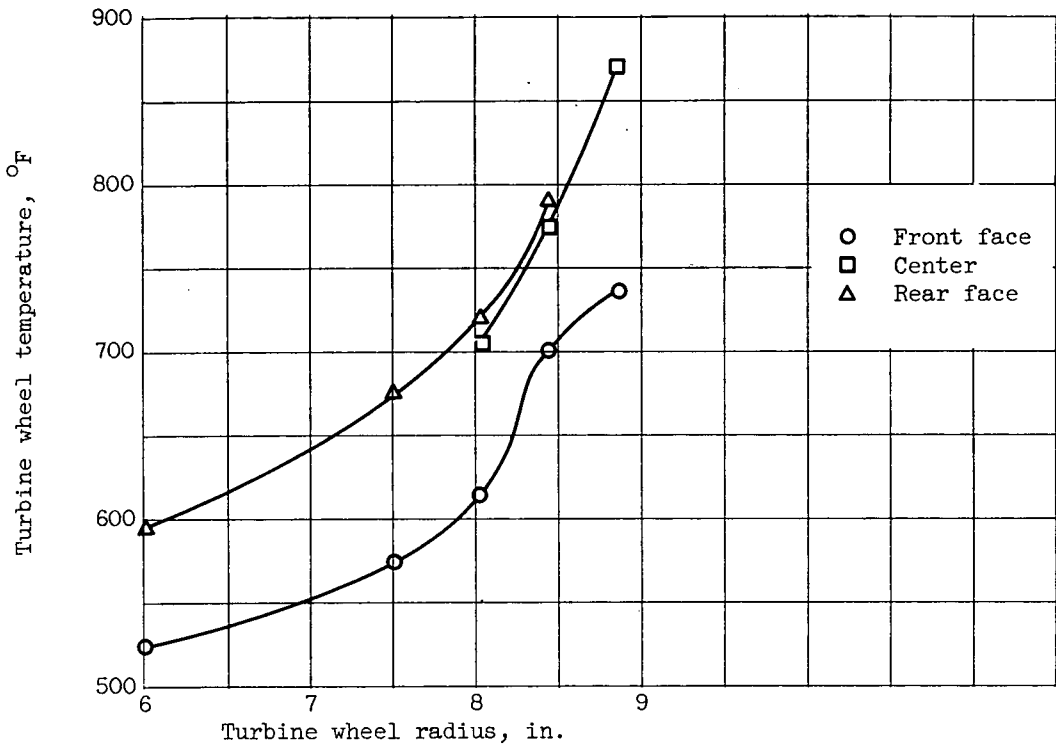

Figure 5. - Turbine wheel temperatures. Cooling air flow, 1 percent of engine air flow.

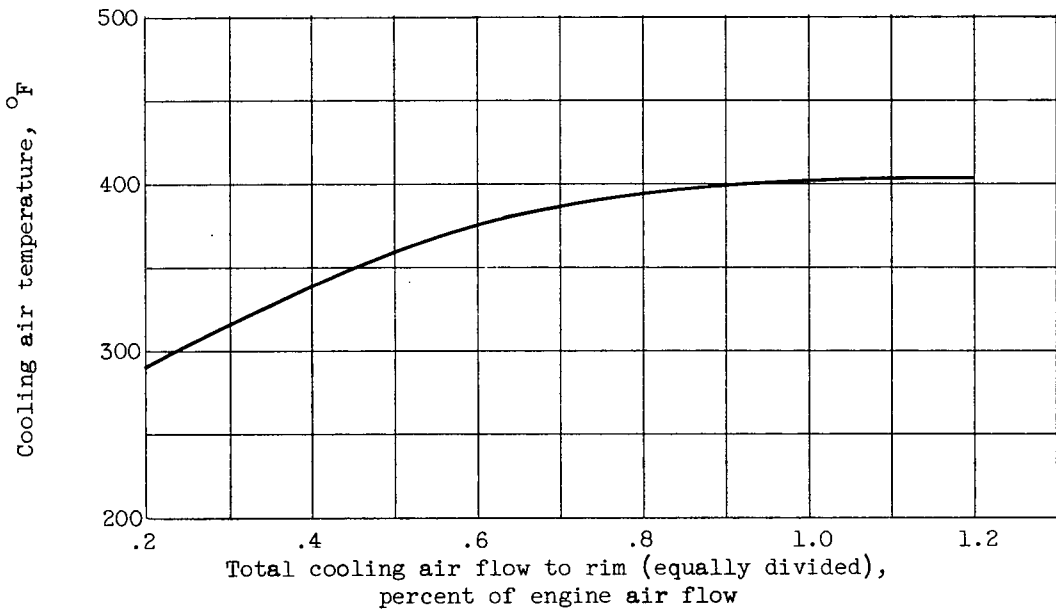

Figure 6. - Variation of cooling air temperature with cooling air flow.

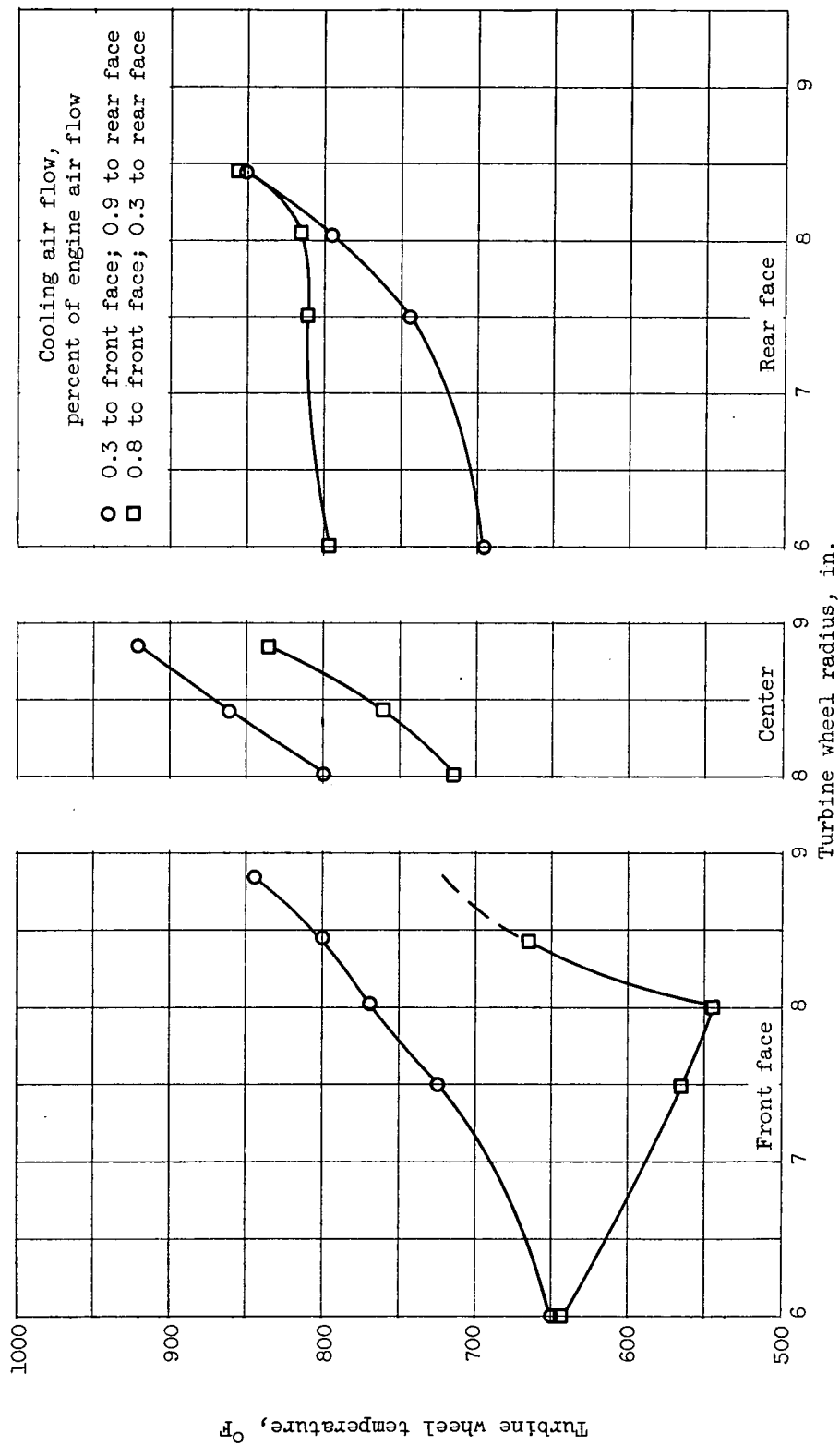
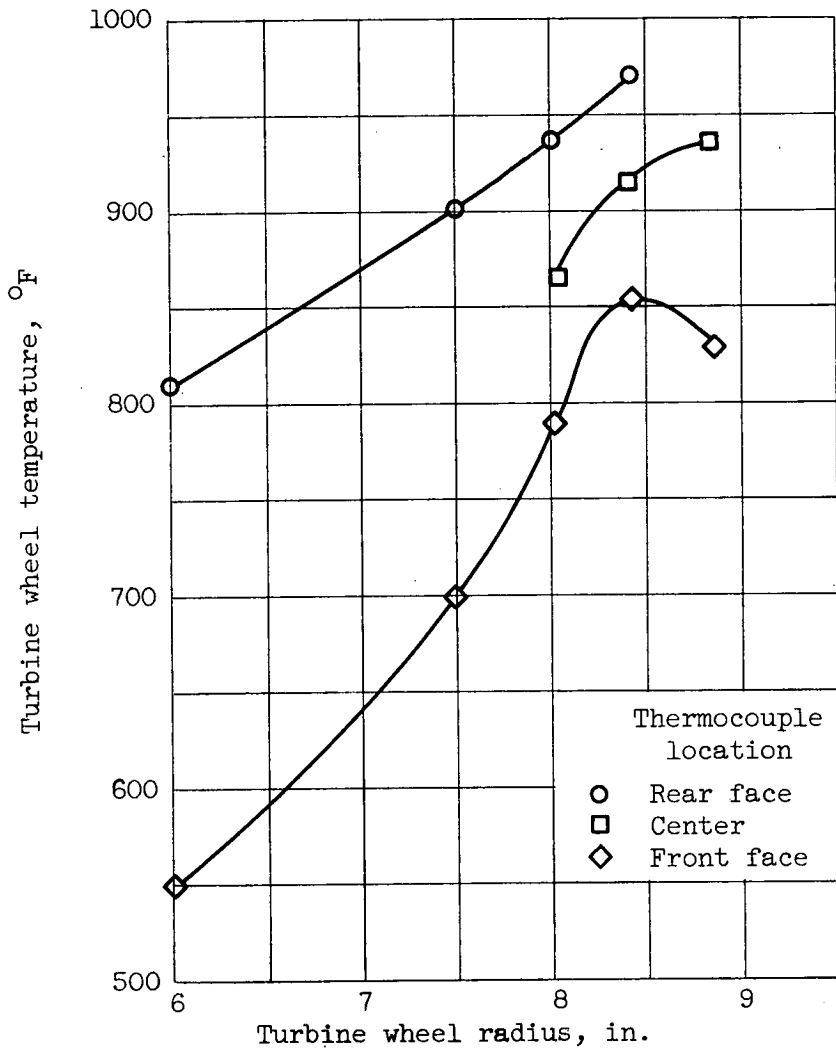
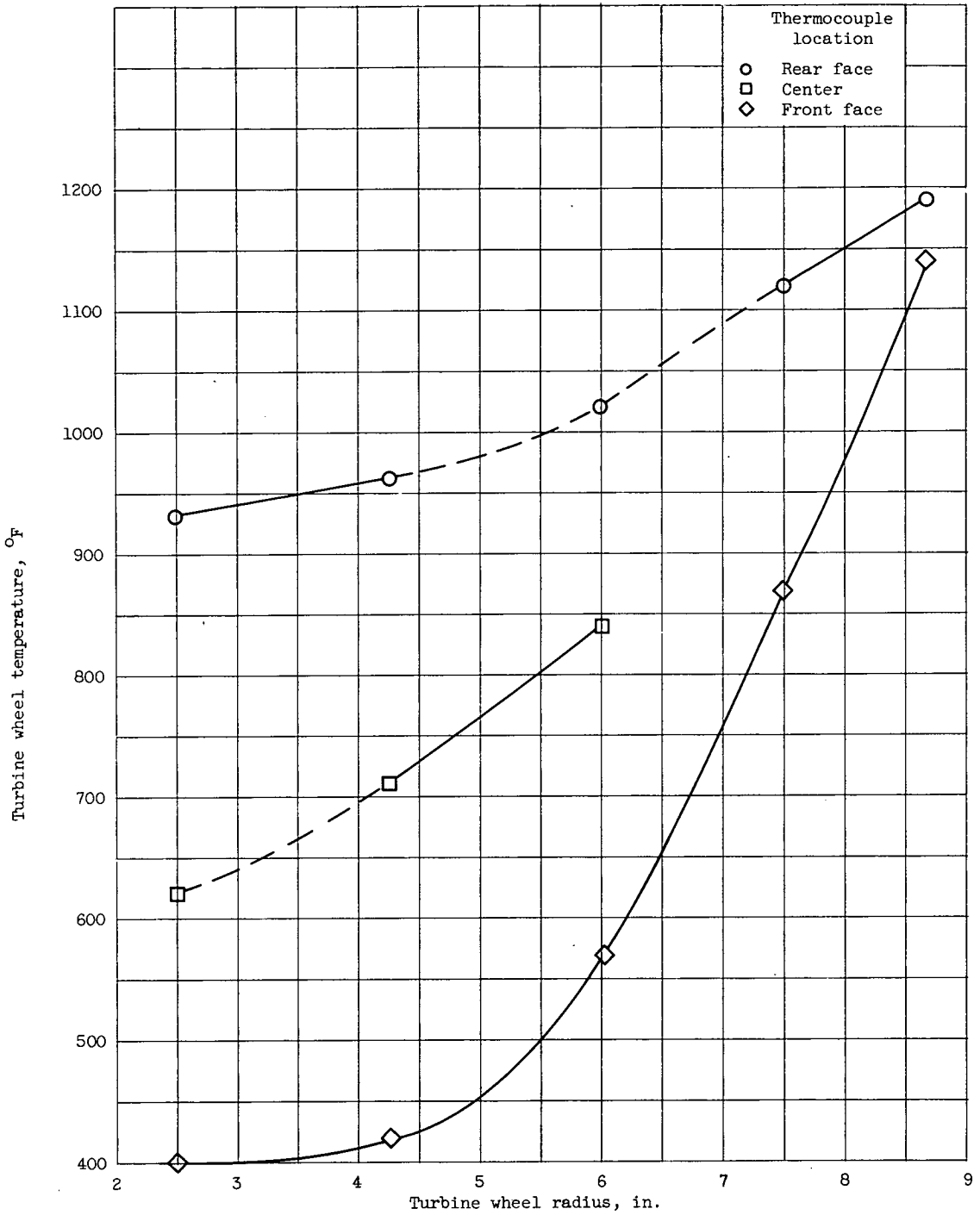

Figure 7. - Turbine wheel temperatures during runs with unbalanced cooling air flow.



(a) Standard J33-A-33 engine.

Figure 8. - Turbine wheel temperature profiles.



(b) J33-9 engine.

Figure 8. - Continued. Turbine wheel temperature profiles.

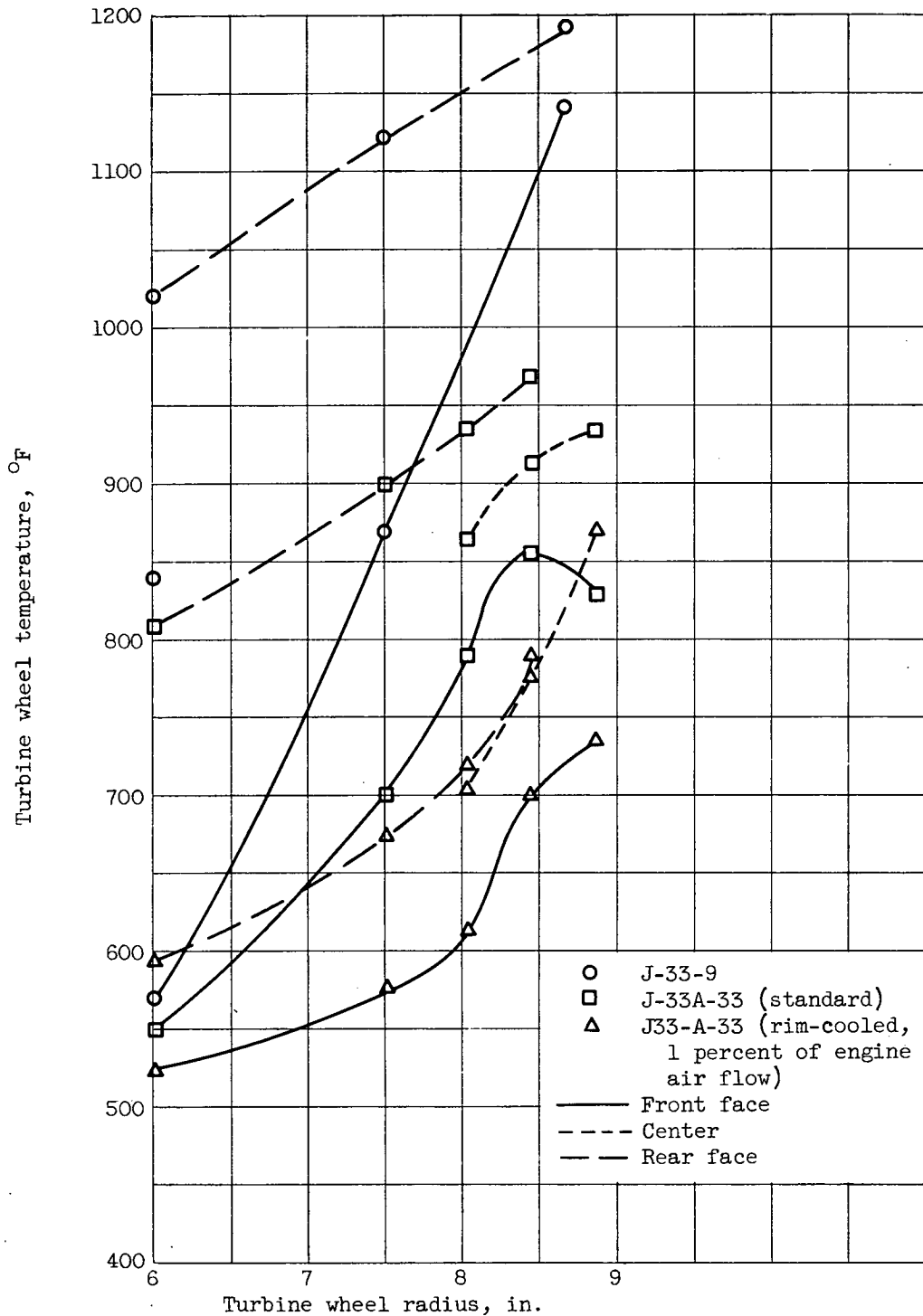

(c) Standard J33-A-33, rim-cooled J33-A-33, and J33-9 engines.

Figure 8. - Concluded. Turbine wheel temperature profiles.

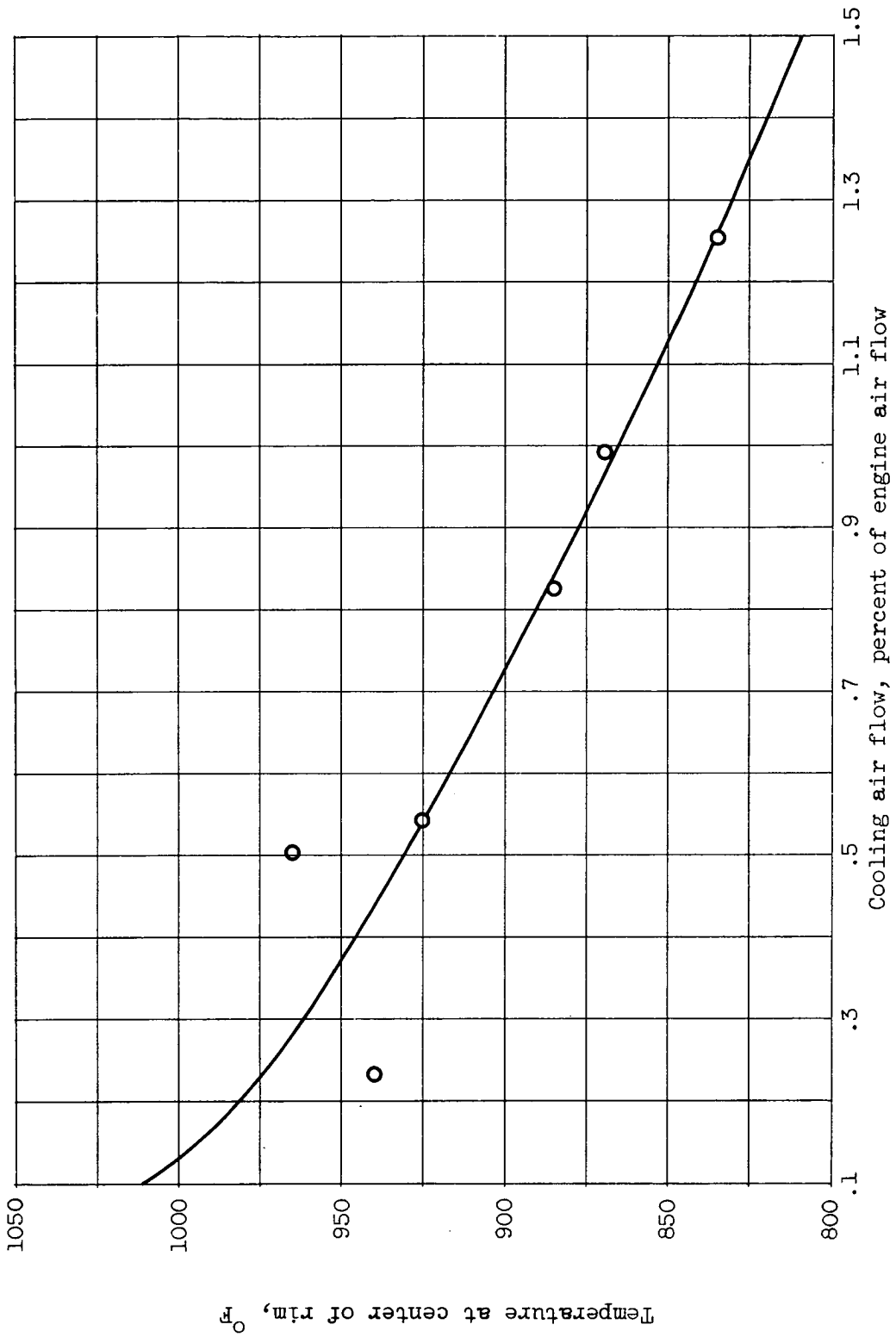

Figure 9. - Variation of maximum turbine wheel temperature with cooling air flow.

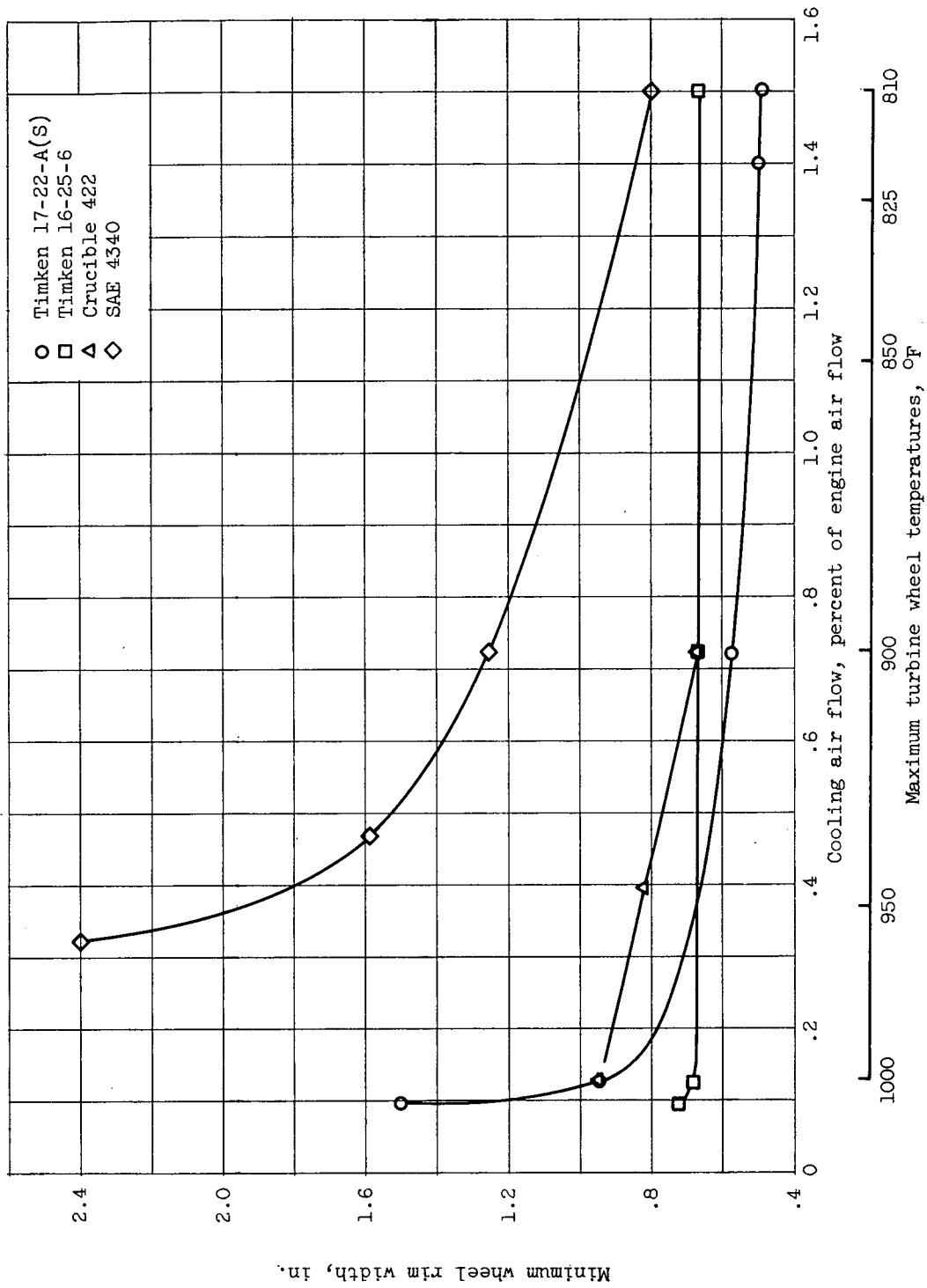

Figure 10. - Variation of minimum turbine wheel rim widths with cooling air flow, based on maximum wheel temperature at center of rim.

