

~~CONFIDENTIAL~~

RM A54B26

NACA RM A54B26

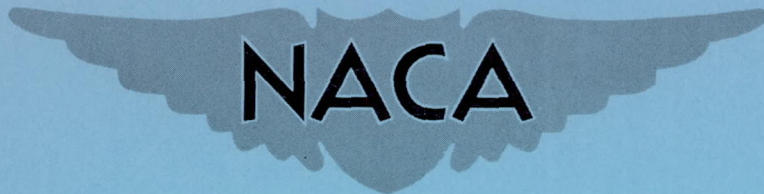

RESEARCH MEMORANDUM

FLIGHT INVESTIGATION OF THE EFFECTS OF A PARTIAL-SPAN
LEADING-EDGE CHORD EXTENSION ON THE AERODYNAMIC
CHARACTERISTICS OF A 35° SWEEP-WING
FIGHTER AIRPLANE

By Frederick H. Matteson and Rudolph D. Van Dyke, Jr.

Ames Aeronautical Laboratory

Moffett Field, Calif.
~~CLASSIFICATION CHANGED TO UNCLASSIFIED~~

AUTHORITY: NACA RESEARCH ABSTRACT NO. 97

DATE: FEBRUARY 24, 1956

WHL

CLASSIFIED DOCUMENT

This material contains information affecting the National Defense of the United States within the meaning of the espionage laws, Title 18, U.S.C., Secs. 793 and 794, the transmission or revelation of which in any manner to an unauthorized person is prohibited by law.

NATIONAL ADVISORY COMMITTEE FOR AERONAUTICS

WASHINGTON

April 23, 1954

~~CONFIDENTIAL~~

NATIONAL ADVISORY COMMITTEE FOR AERONAUTICS

RESEARCH MEMORANDUMFLIGHT INVESTIGATION OF THE EFFECTS OF A PARTIAL-SPAN
LEADING-EDGE CHORD EXTENSION ON THE AERODYNAMIC
CHARACTERISTICS OF A 35° SWEEP-WING
FIGHTER AIRPLANE

By Frederick H. Matteson and Rudolph D. Van Dyke, Jr.

SUMMARY

A flight investigation was made to evaluate the effects of a partial-span, 15-percent-chord, leading-edge extension on the aerodynamic characteristics of the F-86A airplane.

The extension was highly effective in shifting inboard the initial separation of the air flow over the wing for Mach numbers below 0.84, thus eliminating the stick-fixed instability (pitch-up) in this Mach number range. No benefit was observed between $M = 0.84$ and $M = 0.88$. Above $M = 0.88$ where trailing-edge separation occurred, the lift coefficient at which the pitch-up commenced was increased somewhat but the severity was not significantly changed.

The addition of fences did not alter the pitch-up characteristics greatly, but significant changes in the stall behavior and stall warning at low speeds were noted. The extensions caused a small drag penalty which was greatest at Mach numbers above the drag rise.

A correlation between pilot opinion of the severity of the pitch-up and the maximum pitching accelerations was obtained.

INTRODUCTION

Considerable wind-tunnel research has been devoted to improving the undesirable pitching-moment characteristics of swept wings by using such devices as slats, fences, vortex generators, and leading-edge extensions or notches. The effects of some of these modifications on the wing pitching-moment characteristics and stall patterns as well as the pilot

opinion of the resulting flying qualities are being evaluated by using an F-86A airplane as a test vehicle.

Previous flight tests of separation control devices such as vortex generators (ref. 1) and fences (ref. 2) have shown that they are effective in delaying separation to higher normal-force coefficients in the Mach number range from 0.88 to 0.94.

Examination of results of wind-tunnel tests (refs. 3 to 6) of leading-edge chord extensions showed that these devices often improved the pitching-moment characteristics throughout the Mach number range by increasing the lift coefficient for the abrupt decrease in stability or by reducing the severity of this break. The device was generally less effective at higher Mach numbers. It was felt that an extended leading edge possibly with fences or vortex generators might provide improved pitching-moment characteristics of swept-wing airplanes. Accordingly, flight tests similar to those of references 1, 2, and 7 were undertaken of a 0.15-chord, partial-span, leading-edge extension on the F-86 airplane.

SYMBOLS¹

b	wing span
C_D	drag coefficient
$C_{m(w+f)}$	pitching-moment coefficient of wing-fuselage combination about the quarter point of the mean aerodynamic chord
C_{m0}	pitching-moment coefficient at zero normal-force coefficient
C_N	airplane normal-force coefficient
c	local chord
\bar{c}	mean aerodynamic chord, $\frac{2}{S} \int_0^{b/2} c^2 dy$
I_y	moment of inertia in pitch
M	Mach number
q	dynamic pressure
R	Reynolds number, based on \bar{c}

¹All reference dimensions are for the unmodified airplane.

S	wing area
α	angle of attack
δ_e	elevator angle, positive for down deflection
$\ddot{\theta}_{\max}$	maximum pitching acceleration

TESTS

The instrumentation and flight-test techniques were similar to those used in references 1, 2, and 7 with the following exceptions. Longitudinal stability tests at 0.80 Mach number and below were carried out at 35,000 feet altitude. Above 0.80 Mach number the tests were performed at 40,000 feet. The drag measurements were made in lg flight at altitudes from 6,000 feet for 0.50 Mach number to 34,000 feet for 0.90 Mach number in order to maintain a constant value of the normal-force coefficient of 0.15. The data for Mach numbers above 0.90 were obtained in diving flight. Because of the difficulty in maintaining a constant Mach number under these conditions, some variance in Mach number about the nominal value exists for these runs.

DESCRIPTION OF THE MODIFICATION

The leading-edge extension was designed on the basis of tests such as those reported in reference 6. The plan-form dimensions are presented in table I and the airfoil ordinates at two spanwise stations through the extension are presented in table II. The profile through the extension was that of the original wing forward of its position of maximum thickness but stretched uniformly so that the leading edge was 15 percent of the chord forward of its original position. Thus, the contour forward of the maximum thickness position was that of a thinner airfoil with a smaller leading-edge radius. Figure 1 is a plan view of the modified airplane. A close-up view of the leading-edge extension is shown in figure 2.

The extensions were made of wood sections glued to the wing and fastened to a metal structure bolted to the existing leading-edge slat attachment fittings. All gaps were sealed and the inboard leading-edge slats, which were not replaced by the chord extensions, were also bolted closed and sealed.

The fences were 5 percent of the local chord in height. The inboard fence was located at the inboard end of the leading-edge extension ($0.57 b/2$); the outboard one near the center of the leading-edge

extension ($0.74 b/2$). The fences extended from the leading edge back to the aileron hinge line. Photographs of the fence configurations are shown in figure 3.

RESULTS AND DISCUSSION

Longitudinal Stability

Flight measurements of the wing-fuselage pitching moments have been obtained from the records of the balancing tail loads. The stick-fixed stability of the airplane has been determined from records of the elevator angle required for trim. These data will be presented first, followed by a correlation of these results with the flow phenomena on the wing and with the pilot opinion. The wing-fuselage pitching moments are presented in figure 4 and data for the unmodified airplane have been included where available. The moments were taken about the quarter point of the mean aerodynamic chord of the unmodified wing. Because consistent values of C_{m_0} could not be obtained from flight to flight in some instances, all the data comparisons have been made on a basis of $C_{m_0} = 0$. This will not affect the conclusions to be drawn. In order to compare the stability of the wing-fuselage combination with the stick-fixed stability of the airplane, plots are presented in figure 5 of elevator angle as a function of normal-force coefficient. The data reflect the stability of the airplane as flown (center of gravity at 22.3-percent \bar{c}) to permit correlation with pilot opinion.

Leading-edge extension.- Inspection of figures 4 and 5 shows that the most significant effect of the modification was to increase the stability at the higher lift coefficients at Mach numbers up to about 0.83. From figure 5 it is seen that whereas the basic airplane exhibited a loss of stability leading to pitch-up, a stable pitching-moment break was obtained for the modified airplane and the pitch-up was eliminated at these Mach numbers. From 0.84 to about 0.88 Mach number no large changes in pitching-moment behavior are apparent. From 0.88 to 0.93 Mach number² there was an increase in the normal-force coefficient at which the pitch-up occurred from that for the basic airplane but no great difference in the direction or severity of the break. The above Mach number ranges are related to changes in the nature of the separation patterns on the basic wing. This relationship will be discussed under the heading "Flow Phenomena."

In the Mach number range where the modification was effective in eliminating the pitch-up, a region of reduced stability at lower lift

²No data are presented for Mach numbers above 0.91 and conclusions drawn for Mach numbers above this value are based on pilot's opinion.

coefficients was evident. The reduction is particularly apparent in the stick-fixed stability, figures 5(a) and 5(b).

A second effect observed was a general reduction in stability as compared with the basic airplane. The magnitude of this reduction was about what would be expected from the forward shift in centroid of the wing area with the consequent shifting of the quarter point of the mean aerodynamic chord.

Fences.- Tests of fences on the unmodified wing, reference 2, indicated two significant effects: (1) a progressive increase in the normal-force coefficient at which the pitch-up occurs in the Mach number range from 0.88 to 0.93, and (2) marked improvements in the low-speed stalls. To see if these benefits were cumulative with the effects of the leading-edge extensions, tests were conducted with a fence at either the inboard end of the extension or at a position near the midspan of the extension.

The inboard fence did not materially affect the longitudinal stability characteristics at any Mach number and no data are presented. The wing-fuselage pitching moments of the outboard fence configuration are compared with those for the leading-edge extension alone in figure 6. The outer fence increased slightly the normal-force coefficient for the unstable break at Mach numbers greater than 0.86 in a manner similar to that shown in reference 2. This small improvement had no important effect on the stick-fixed stability characteristics of the airplane, as shown in figure 7.

Figure 8 summarizes the "boundaries" of normal-force coefficient for the unstable break in the pitching moment for the unmodified airplane and the two modified configurations as determined from records of pitching velocity and elevator angle. Shaded regions are shown to indicate the amount of scatter in the data.

Flow phenomena.- Fundamentally, the pitch-up on sweptback-wing airplanes such as the F-86 results from the initial stalling with loss of lift over the outer portions of the wings. It would be expected that changes in stability would be reflected in the separation pattern, that the severity of the change in stability could be correlated with the stall progression, and that remedial measures to be taken could be dictated from knowledge of the type and position of the initial separation. In accordance with this reasoning, studies of the behavior of surface tufts were made using motion pictures of the wing in longitudinal pull-up maneuvers.

The results of these tests showed that the chordwise position of initial separation moved rearward with increasing Mach number following the progression of the large adverse pressure gradient. Separation on the basic wing first appeared:

1. At the leading edge for Mach numbers up to about 0.80.
2. At midchord for Mach numbers between about 0.80 and 0.86.
3. At the trailing edge for Mach numbers between about 0.86 and 0.94. This pattern is associated with the severe adverse pressure gradient which fans out from the intersection of the fuselage and the wing trailing edge. Although separation initiates here at Mach numbers above 0.94, it does not spread forward sufficiently to cause instability at the lift coefficients reached in flight.

An example of the leading-edge-pattern progression is shown in part (a) of figure 9 for speeds corresponding to the lg stall. Initial flow separation occurred from the leading edge near the wing tip and progressed inboard as the lift coefficient increased. The separation patterns were not sharply defined for this case, and unsteady outboard flow was observed prior to the leading-edge separation. A corresponding pitching-moment curve is not available for comparison; however, the pitching-moment curves for this Mach number range exhibit a moderate unstable break at comparatively high lift coefficients. The pilots regarded the pitch-up as barely detectable up to 0.7 Mach number, gradually increasing in intensity then to 0.8 Mach number. A pitch-up may occur at the stall at 0.7 Mach number; however, documentation of such was impossible because of a quite abrupt roll-off. Previously, partial-span leading-edge slats, devices effective in delaying leading-edge separation, have been effective in eliminating the pitch-up in this Mach number range (ref. 1). The leading-edge extension was likewise effective; the separation progression is shown in part (b) of figure 9. The large changes in pitching behavior are immediately evident in the flow separation patterns. Whereas on the basic wing initial separation occurred near the tip, on the modified wing the initial separation occurred just inboard of the leading-edge extension and its progression was primarily inboard. The leading-edge extension is a very powerful deterrent to tip separation. At the higher lift coefficients clear evidence of a region of separated flow with subsequent reattachment appeared over the middle portion of the leading-edge extension.

Above about 0.80 Mach number the initial separation began to appear as a narrow region approximately parallel to the leading edge. The exact nature of the initial separation is not clear; the appearance was that of a forked shock with strong vorticity in the separated region. A representative progression is shown in part (a) of figure 10 at a Mach number of 0.82. In the midspan position of the aileron the separated region extended to the trailing edge. As the Mach number increased, the position of the separation and reattachment moved rearward. Limited data show increases rather than decreases in lift-curve slope accompanying this phenomenon. The pitch-up became progressively more abrupt as the Mach number increased. This increase in severity would

seem to result from the increase in stability at low lift coefficients with the greater resultant shift in the center of pressure when the stalling occurs. Such devices as have been tried to date have provided little or no change in the characteristics in this Mach number range (refs. 1 and 2). The leading-edge extension was effective in eliminating the pitch-up to about 0.83 Mach number. Above 0.84 the break was again unstable. An example of the separation progression is shown in figure 10(b) for 0.82 Mach number for the leading-edge extension with outboard fence. The tendency toward midchord separation is still there but the patterns have been altered in a manner similar to that observed in figure 9. At the higher Mach number the modified wing exhibited a greater tendency toward tip separation than at the lower Mach number. Again, the leading-edge extension prevented separation over the outer wing panel and thus prevented the pitch-up. However, as the Mach number increased and the point of initial separation moved aft, the device became less effective in the control of separation.

At Mach numbers from 0.86 to 0.88 the midchord separation changed to separation behind the trailing-edge shock emanating from the fuselage trailing-edge juncture. The pitch-up became most violent at about 0.89 Mach number when the line of separation moved forward rapidly with increasing normal-force coefficient. Above 0.92 Mach number the violence of the motion decreased so that at 0.94 Mach number where the flow over the wing is largely supersonic, no pitch-up has been encountered. Fences and vortex generators (refs. 1 and 2) have been effective in increasing boundary-layer momentum in the region where momentum loss is high (over the trailing-edge portion of the wing) and the lift coefficient for the pitch-up has been raised by these devices. Figure 11 gives a comparison of the stall progression at approximately 0.90 Mach number with the accompanying wing-fuselage pitching moments for the basic airplane and for the airplane modified with extensions and outboard fences. The modification delayed the unstable break to a higher lift coefficient; however, a rapid stalling of the outer wing panel caused a large loss in stability again leading to pitch-up. The improvement obtained was not as a result of a delay in separation but as an alteration in the spanwise progression.

Pilot opinion.- As many factors may influence pilot opinion of pitch-ups, a classification is presented of the factors that are believed to be important. Assuming the predominant item influencing pilot opinion is his ability to control the aircraft, we may classify the pertinent factors which govern this ability as follows:

- (1) The abruptness of the break in the pitching-moment curves.
- (2) The dynamic response parameter, $I_y/qS\bar{c}$.
- (3) The pilot response time and his ability (rate) to make corrective action.
- (4) The control effectiveness.

The first two factors will govern the severity of the pitch-up or pitching acceleration. The second two factors govern the pilot's ability to arrest the pitching. In the present tests the same pilot and elevator control system were used throughout so only the factors (1) and (2) affecting the accelerations remain. As the differences in moments of inertia and dynamic pressure were not large, the first factor remains as the principal variant. Therefore, by comparing the maximum pitching accelerations and pilot opinion, an evaluation of the effects of changes in the pitching-moment curves on the longitudinal characteristics at different speeds may be obtained from the tests.

In figure 12 the effect of the modifications on the maximum pitching accelerations is shown for pitching maneuvers where the pilot held the stick fixed at the pitch-up. Because the onset of the pitch-up was often abrupt, the pilot was not always able to hold the stick fixed and approximate corrections have been applied in such cases. It should be kept in mind that these maneuvers were done slowly and smoothly at high altitude; the opinions stated reflect the relative severity of the pitch-up with and without modifications under these conditions and not necessarily the severity or suitability under service conditions. For the basic airplane the pitching acceleration increases quite abruptly at about 0.82 Mach number to a maximum at about 0.89. For both the leading-edge extension and extension with fence configurations, no pitch-up existed; hence, the accelerations up to about 0.83 Mach number are just maximum pilot inputs in his wind-up turn and are of the order of 0.1 radian per second squared. The accelerations then rise abruptly to the same level as for the basic airplane at about 0.87 Mach number. The obvious important change achieved in the modification was in the pitching-moment characteristics, and the changes in pitching-moment curves are reflected in the accelerations (fig. 12). The pilot considered the pitch-up for the basic airplane at 0.70 Mach number as very mild ($\ddot{\theta}_{\max} \approx 0.2$) and moderate at 0.80 ($\ddot{\theta}_{\max} \approx 0.3$) and severe above 0.85 ($\ddot{\theta}_{\max} \approx 0.5$).

Other factors influenced the pilot's opinion of the modifications. Although the pilot was favorably impressed with the elimination of the pitch-up below 0.84 Mach number, flight at high lift coefficients would not be considered entirely satisfactory because buffeting was not eliminated. Further, the modified airplane became almost neutrally stable at normal-force coefficients of about 0.2 to 0.4 and consequently was very difficult to fly since only about one degree of elevator deflection was required to change C_N by 0.2. This was objectionable to the pilot at the test altitude, where it occurred at the normal-force coefficient required for level flight.

From this discussion it appears that in flying, such as was done for these tests, the pilot is not impressed by a small change in the normal-force coefficient at which an instability occurs if the severity of instability remains unchanged, and that he is quite sensitive to the amount of stability apparent to him. A region of neutral stability is less tolerable when it occurs at the normal-force coefficient for level flight.

Low-Speed Stalls

Care must be taken in applying these or similar modifications to avoid bad low-speed stalling characteristics. Following the procedure in reference 8, the effects of the present modifications were evaluated by the pilot on the basis of the adequacy of the stall warning to avoid stall, and the quality of the stability, control, and buffet characteristics. The results of the stall tests are given in table III. Ratings by the same pilot on the standard service configuration of the F-86A are included for reference.

Whereas the service airplane had satisfactory characteristics with slats operating (except for stall warning when flaps and gear were down), the locking and sealing of the slats caused a serious deterioration of the characteristics both when the flaps and gear were up or down.

For the leading-edge-extension tests the slats and extensions were sealed. For the configuration without fence, the stall warning and stall were satisfactory with flaps and gear up. With flaps and gear down the warning was delayed to very near the stall and the stall was accompanied by abrupt rolling.

The tests in references 2 and 9 indicated that fences would improve the stall with flaps down. The addition of a fence at the discontinuity in the leading edge resulted in poorer stalling characteristics - more severe buffet when the flaps and gear were up, and more abrupt rolling at the stall when the flaps and gear were down. Relocating the fence near the midspan of the extension, however, resulted in stalling characteristics that were approximately equal to those for the service airplane with slats. With the flaps down the quality of the stall was very good although the warning was still considered to be too near the stall.

Drag

Measurements of the drag at $C_N=0.15$ are presented in figure 13. A small drag penalty appears due to the leading-edge extension at sub-critical Mach numbers. This penalty increases with increasing Mach number to about 0.0050 at $M = 1.04$. The trends for the lower Mach numbers are similar to those observed in reference 6. No drag measurements were made at high lift coefficients. The results of the tunnel test (ref. 6) showed that the drag increment disappears at the higher lift coefficients and becomes negative at still higher lift coefficients, particularly at the lower Mach numbers, hence the flight tests made probably show the penalty in the region of its maximum.

CONCLUSIONS

Flight tests of a 15-percent-chord, partial-span, leading-edge extension on a 35° sweptback-wing airplane resulted in the following conclusions:

1. At Mach numbers where the initial separation was from the forward portion of the chord over the tip portion of the wing ($M < 0.83$) the addition of the extension eliminated the loss of stability with increasing lift coefficient (pitch-up). However, a limited region of neutral stick-fixed stability appeared above normal-force coefficients of 0.2 to 0.4.

2. At Mach numbers where flow separation occurred over the trailing-edge portion of the wing ($M = 0.88$ to 0.93), the addition of the extension produced an increase in the normal-force coefficient at which the pitch-up occurred above that for the original airplane, but made no significant change in the direction or severity of the break.

3. The addition of a fence at the discontinuity had either detrimental or negligible effects. The addition of a fence at the midspan of the extension increased slightly the normal-force coefficient for the pitch-up at Mach numbers where trailing-edge separation occurred.

4. The low-speed-stall flying qualities with the leading-edge extension were as good as the normal service airplane with flaps up. The stall with flaps down was less satisfactory with only the extension because of abrupt rolling at the stall. The addition of a fence to the 74-percent-semispan position made the stalling as good as the service airplane. The fence at the discontinuity caused poorer stalling characteristics.

5. The extension caused a small drag penalty at 0.15 normal-force coefficient which was greatest at Mach numbers above the drag rise.

6. The pilot considered the modified airplane greatly improved at Mach numbers at which the pitch-up was eliminated, although not entirely satisfactory because of the low stability at moderate lift coefficients and lack of improvement in buffeting at high lift coefficients. The pilot did not appreciate the postponement of the pitch-up to higher lift coefficients because no reduction in the severity of the pitching was realized.

Ames Aeronautical Laboratory
National Advisory Committee for Aeronautics
Moffett Field, Calif., Feb. 26, 1954

REFERENCES

1. McFadden, Norman M., Rathert, George A., Jr., and Bray, Richard S.: The Effectiveness of Wing Vortex Generators in Improving the Maneuvering Characteristics of a Swept-Wing Airplane at Transonic Speeds. NACA RM A51J18, 1952.
2. Bray, Richard S.: The Effects of Fences on the High-Speed Longitudinal Stability of a Swept-Wing Airplane. NACA RM A53F23, 1953.
3. Furlong, G. Chester: Exploratory Investigation of Leading-Edge Chord-Extensions to Improve the Longitudinal Stability Characteristics of Two 52° Sweptback Wings. NACA RM L50A30, 1950.
4. Jaquet, Byron M.: Effects of Chord Discontinuities and Chordwise Fences on Low-Speed Static Longitudinal Stability of an Airplane Model Having a 35° Sweptback Wing. NACA RM L52C25, 1952.
5. Goodson, Kenneth W., and Few, Albert G., Jr.: Effect of Leading-Edge Chord-Extensions on Subsonic and Transonic Aerodynamic Characteristics of Three Models Having 45° Sweptback Wings of Aspect Ratio 4. NACA RM L52K21, 1953.
6. Selan, Ralph, and Bandettini, Angelo: The Effects of Leading-Edge Extensions, A Trailing-Edge Extension, and a Fence on the Static Longitudinal Stability of a Wing-Fuselage-Tail Combination Having a Wing With 35° of Sweepback and an Aspect Ratio of 4.5. NACA RM A53E12, 1953.
7. Anderson, Seth B., and Bray, Richard S.: A Flight Evaluation of the Longitudinal Stability Characteristics Associated With the Pitch-Up of a Swept-Wing Airplane in Maneuvering Flight at Transonic Speeds. NACA RM A51I12, 1951.
8. Anderson, Seth B.: Correlation of Flight and Wind-Tunnel Measurements of Roll-Off in Low-Speed Stalls on a 35° Swept-Wing Aircraft. NACA RM A53G22, 1953.
9. Anderson, Seth B., Matteson, Frederick H., and Van Dyke, Rudolph D., Jr.: A Flight Investigation of the Effect of Leading-Edge Camber on the Aerodynamic Characteristics of a Swept-Wing Airplane. NACA RM A52L16a, 1953.

TABLE I.- PERTINENT AIRPLANE DIMENSIONS

[See reference 1 for more complete dimensions of basic airplane]

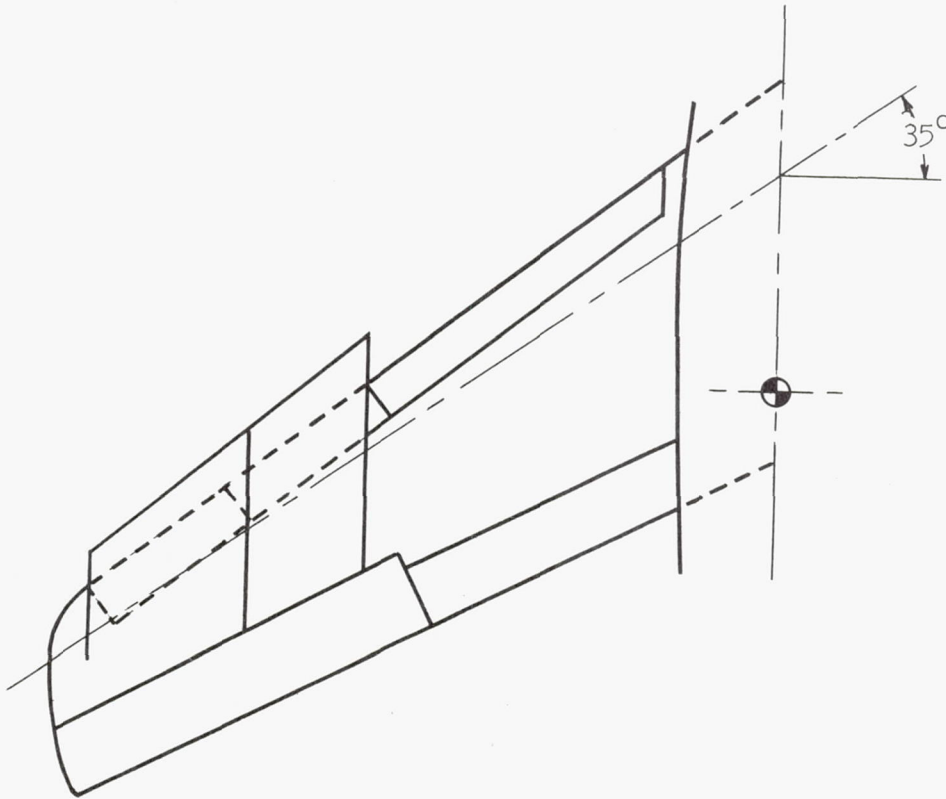

Wing area

Basic airplane, sq ft	287.9
Modified airplane, sq ft	302.1

Aspect ratio

Basic airplane	4.79
Modified airplane	4.56

Mean aerodynamic chord

Basic airplane, ft	8.08
Modified airplane, ft	8.49

Span of leading-edge extension, $b/2$	0.387
Inboard limit of leading-edge extension, $b/2$	0.570
Outboard limit of leading-edge extension, $b/2$	0.957
Position of inboard fence, $b/2$	0.570
Position of outboard fence, $b/2$	0.741
Height of fences, percent of local chord	5
Position of $1/4 \bar{c}$ point of the wing with the extended leading edge with respect to the $1/4 \bar{c}$ point for the basic airplane, percent \bar{c}	-3.7

TABLE II.- ORDINATES OF THE LEADING-EDGE EXTENSION¹
 [Station numbers correspond to the distance along the quarter-chord line from its intersection with the plane of symmetry]

Station 152					
Original ordinates			Modified ordinates		
Horizontal	Upper	Lower	Horizontal	Upper	Lower
-18.666	0.151	- - -	-30.41	0.250	- - -
-18.554	.626	-0.345	-30.20	.750	-0.270
-18.442	.816	-.537	-30.00	.980	-.470
-18.293	.990	-.708	-29.80	1.170	-.625
-18.106	1.170	-.891	-29.20	1.530	-.980
-17.733	1.437	-1.170	-28.00	1.990	-1.460
-16.799	1.902	-1.639	-25.00	2.620	-2.160
-14.933	2.476	-2.241	-23.00	2.900	-2.500
-13.066	2.860	-2.656	-20.00	3.210	-2.880
-11.200	3.151	-2.977	-15.00	3.620	-3.360
-7.466	3.568	-3.452	-10.00	3.880	-3.700
-3.733	3.855	-3.792	-4.00	4.120	-4.025
0	4.053	-4.057	1.00	4.200	-4.210
3.733	4.180	-4.240	8.00	4.250	-4.380
7.466	4.242	-4.362	10.20	- - -	Tangent
11.200	4.247	-4.425	11.10	Tangent	- - -
14.933	4.183	-4.423	- - -	- - -	- - -
Station 251					
Original ordinates			Modified ordinates		
Horizontal	Upper	Lower	Horizontal	Upper	Lower
-13.889	-0.153	- - -	-22.90	-0.250	- - -
-13.806	.200	-.491	-22.80	.110	-0.530
-13.723	.332	-.621	-22.60	.320	-.790
-13.611	.467	-.746	-21.80	.720	-1.250
-13.472	.597	-.876	-20.80	1.050	-1.560
-13.195	.790	-1.071	-19.00	1.450	-1.890
-12.500	1.133	-1.393	-17.00	1.765	-2.150
-11.111	1.565	-1.798	-11.00	2.380	-2.640
-9.722	1.865	-2.069	-9.00	2.525	-2.740
-8.334	2.098	-2.273	-3.00	2.860	-2.950
-5.556	2.443	-2.559	1.00	3.010	-3.010
-2.778	2.702	-2.756	6.00	3.130	-3.010
0	2.893	-2.889	7.80	Tangent	- - -
2.778	3.036	-2.969	8.80	- - -	Tangent
5.556	3.131	-3.003	- - -	- - -	- - -
8.334	3.187	-2.996	- - -	- - -	- - -
11.111	3.192	-2.944	- - -	- - -	- - -

¹All dimensions in the horizontal plane are measured perpendicular to the 25-percent chord line. Dimensions in the vertical plane are measured from the wing reference plane. All dimensions are in inches.



TABLE III.- EVALUATION OF STALLING CHARACTERISTICS

Configuration ¹	Stall (2)	Stall warning (2)
Basic service airplane with slats operating		
Flaps and gear up	S	S
Flaps and gear down	S	U
Basic service airplane - slats locked and sealed		
Flaps and gear up	U	U
Flaps and gear down	U	U
Leading-edge extension		
Flaps and gear up	S	S
Flaps and gear down	MS	U
Leading-edge extension with fence at 0.57 b/2		
Flaps and gear up	S	MS
Flaps and gear down	U	U
Leading-edge extension with fence at 0.74 b/2		
Flaps and gear up	S	S
Flaps and gear down	S	U

¹All configurations were rated by pilot Rudolph D. Van Dyke, Jr.

²Code: U - Unsatisfactory
MS - Marginally satisfactory
S - Satisfactory



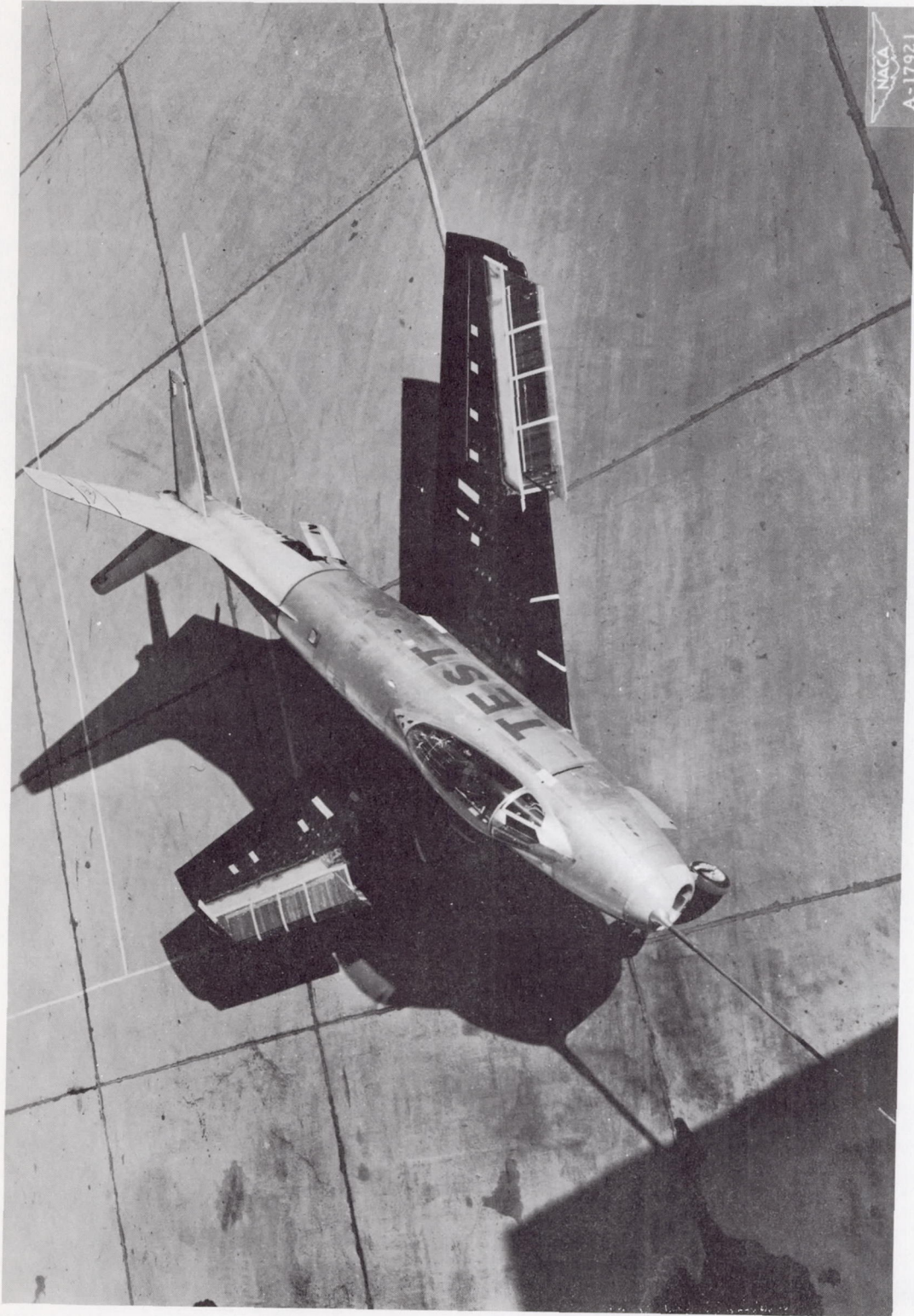

Figure 1.- Plan view of the modified airplane.

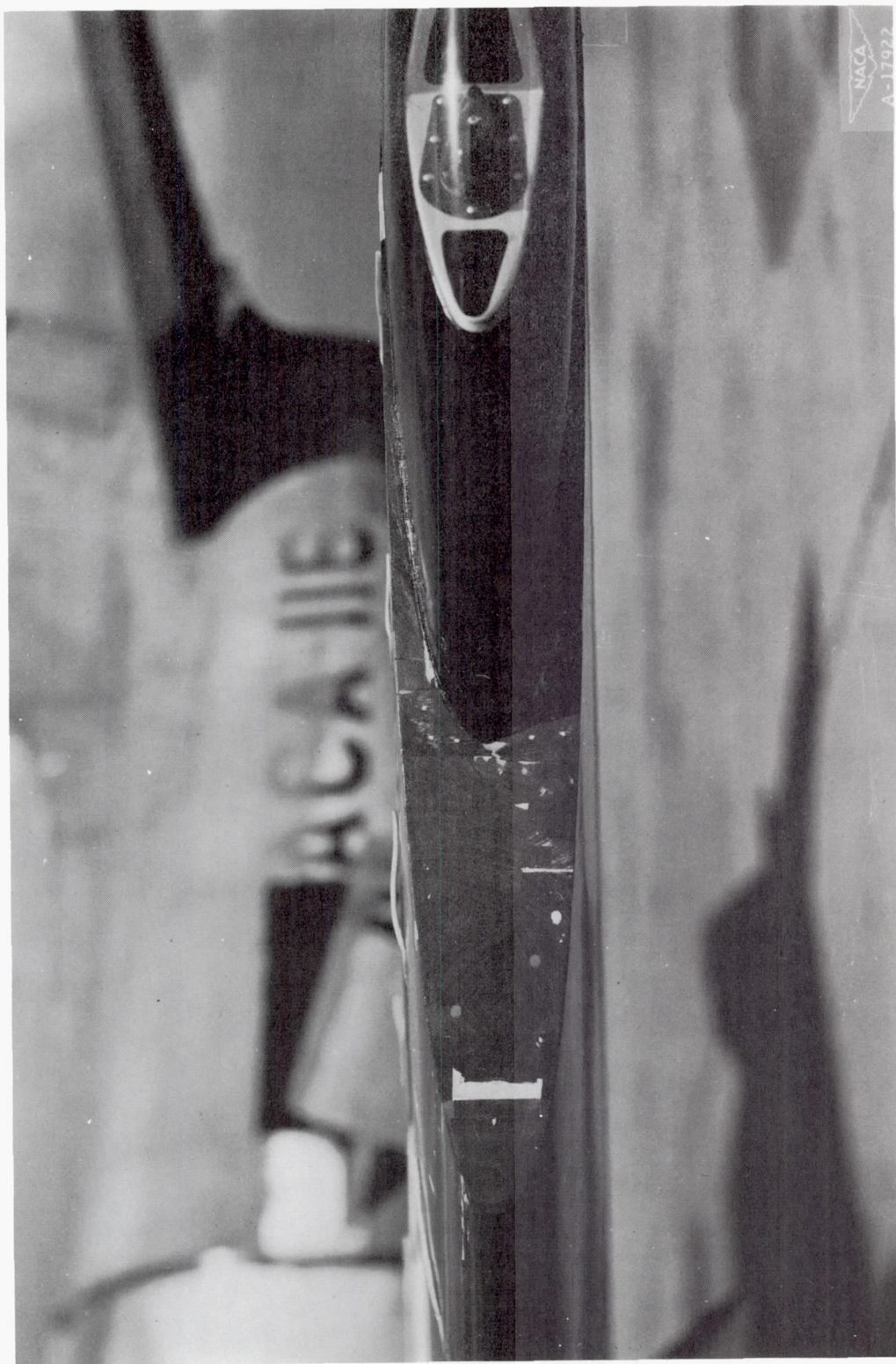
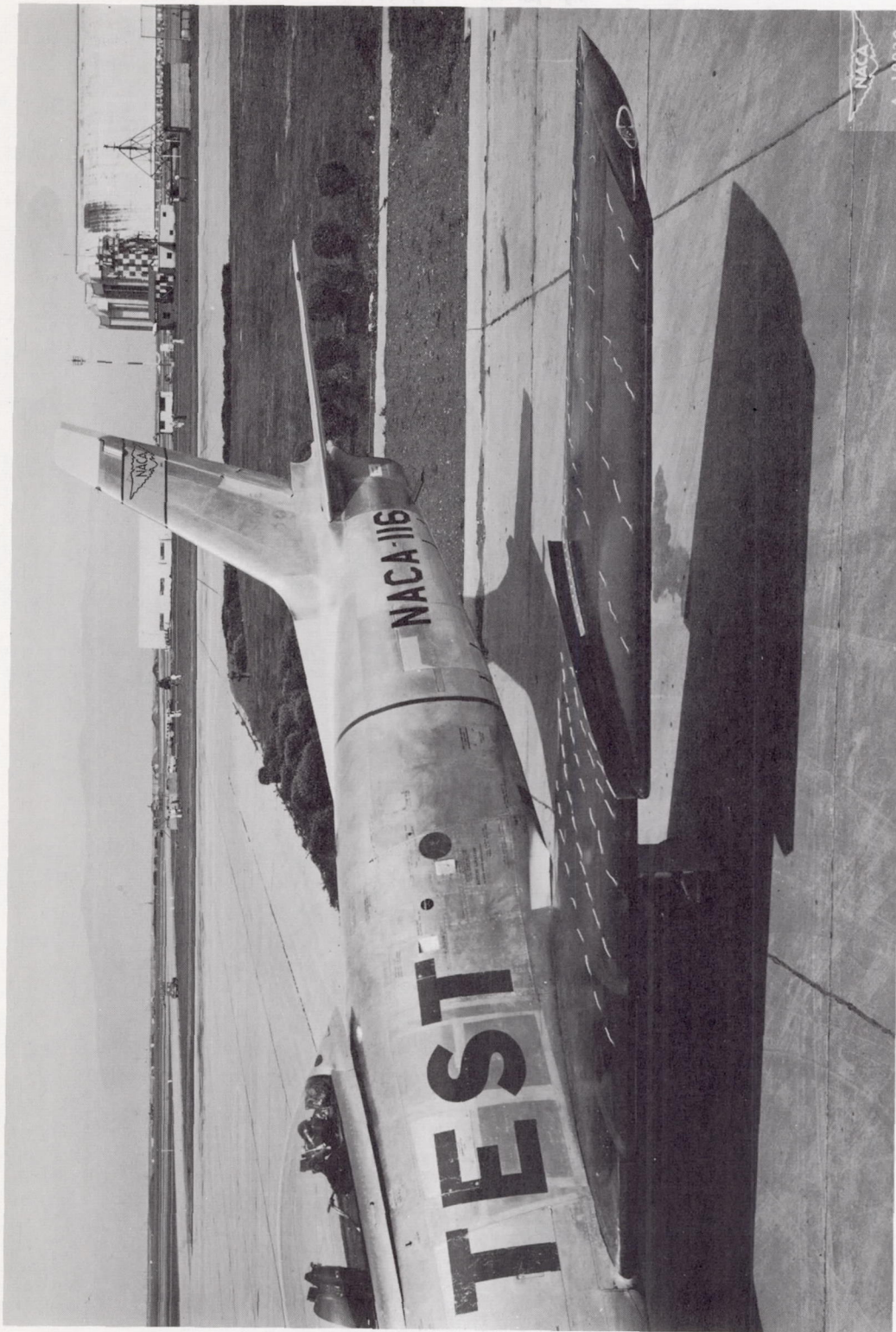

Figure 2.- Outboard end of leading-edge extension.



(a) Inboard fence.

Figure 3.- Fence installations on leading-edge extension.



(b) Outboard fence.

Figure 3.- Concluded.

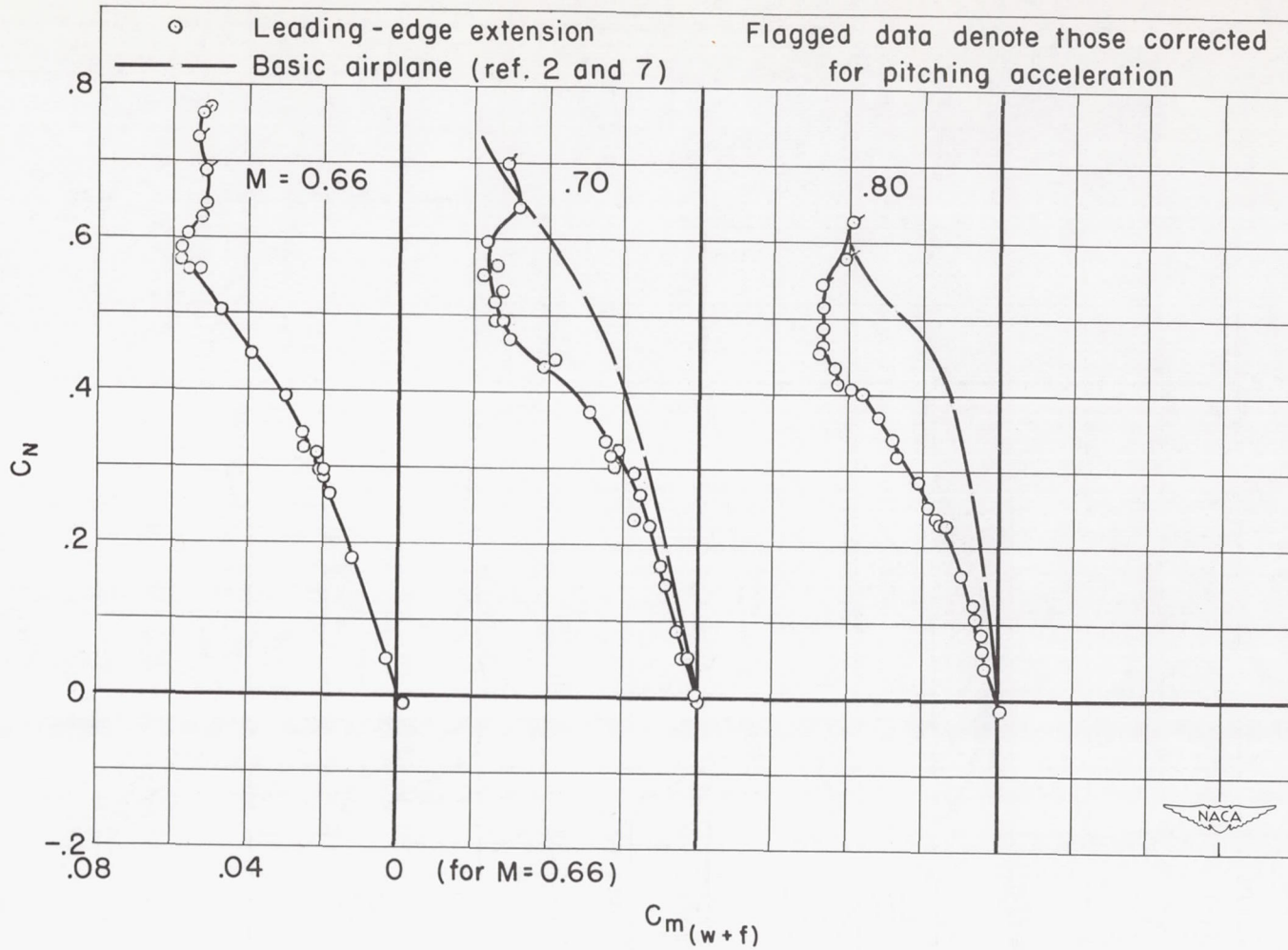

(a) M = 0.66 to 0.80

Figure 4.- Comparison of wing-fuselage pitching moments for the extended-leading-edge configuration with those of the basic airplane; moment reference point $0.25 \bar{c}$.

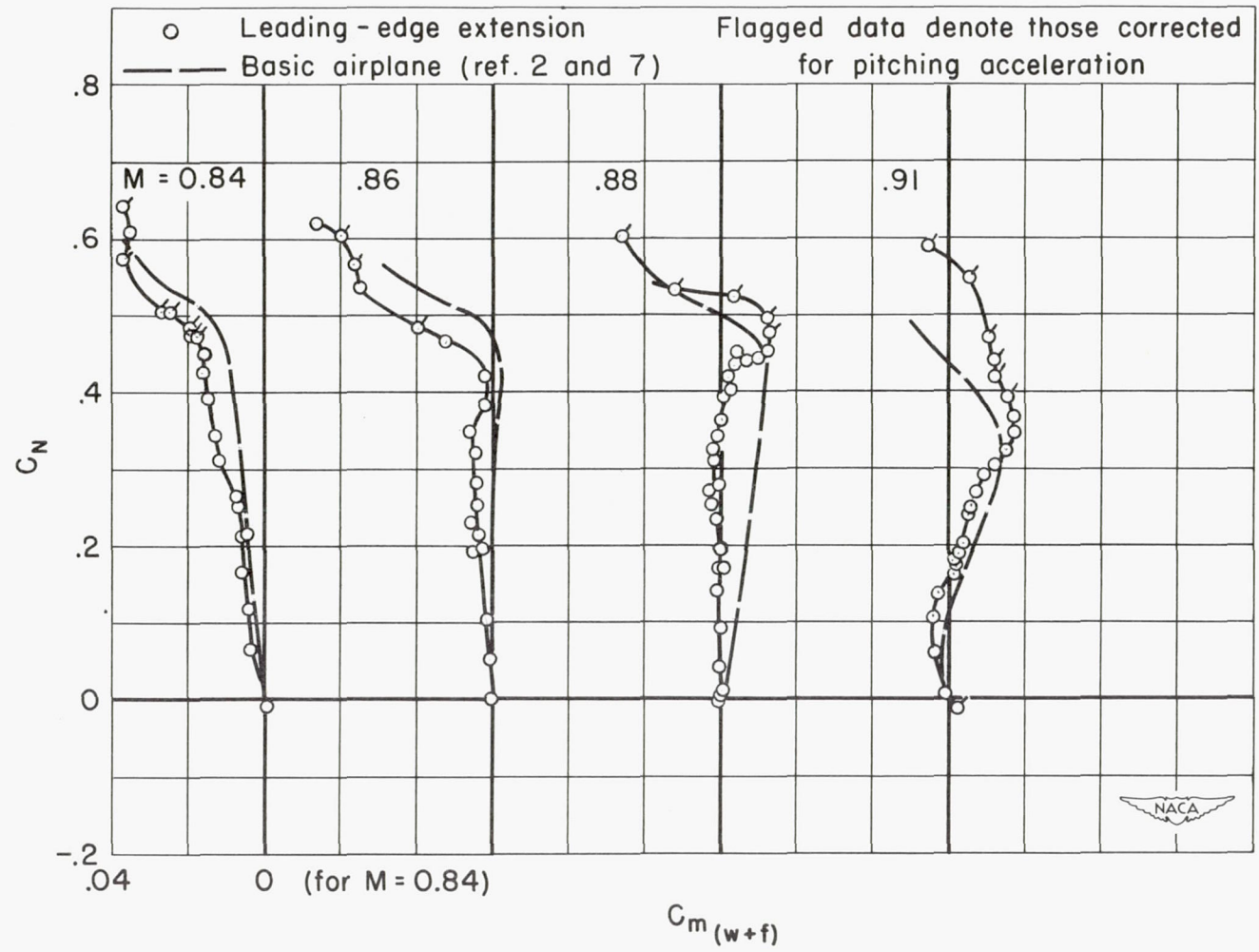

(b) M = 0.84 to 0.91

Figure 4.- Concluded.

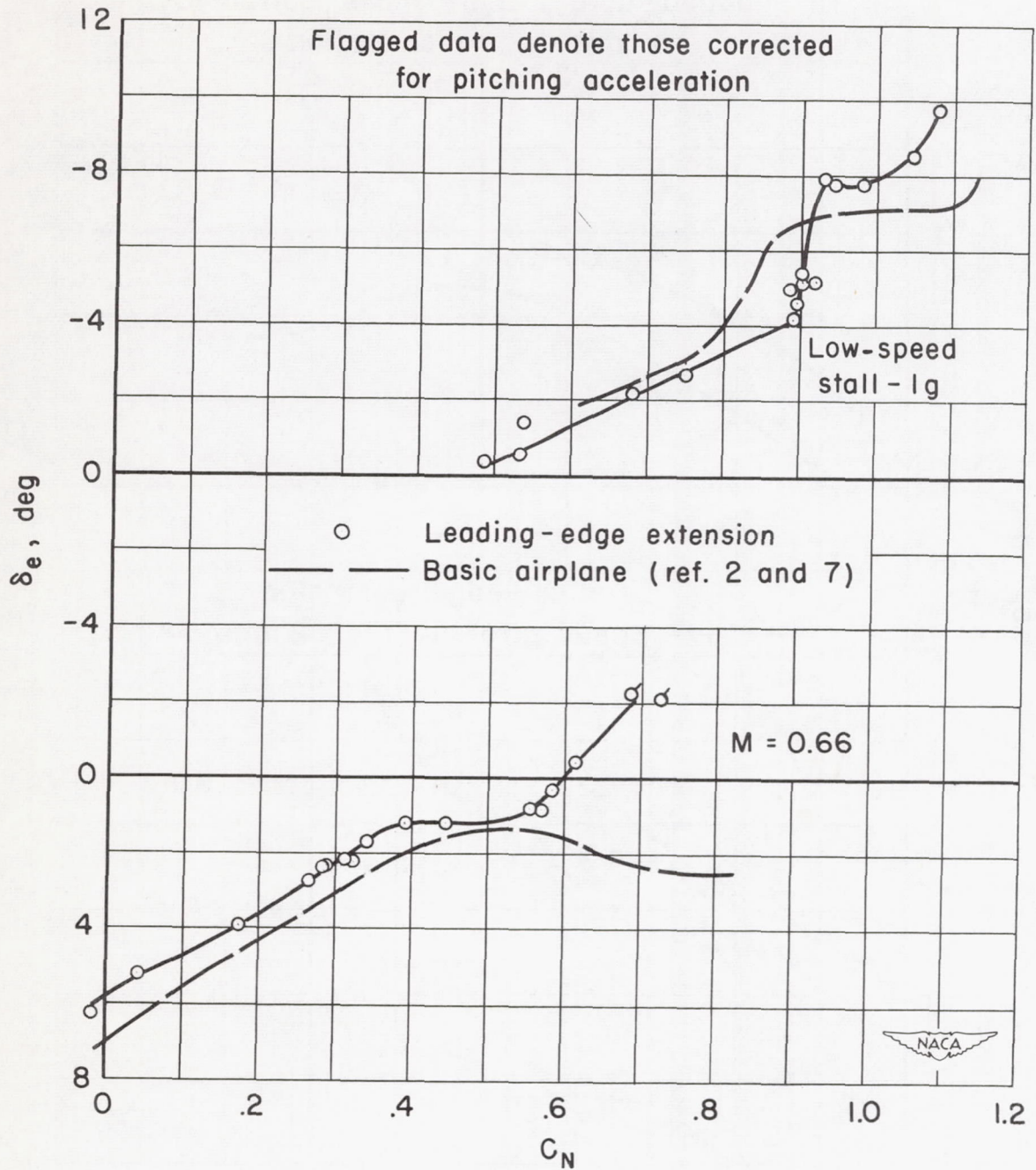

(a) Low-speed stall and $M = 0.66$.

Figure 5.- Elevator angle versus normal-force coefficient; leading-edge extension without fence; center of gravity 22.3 percent \bar{c} .

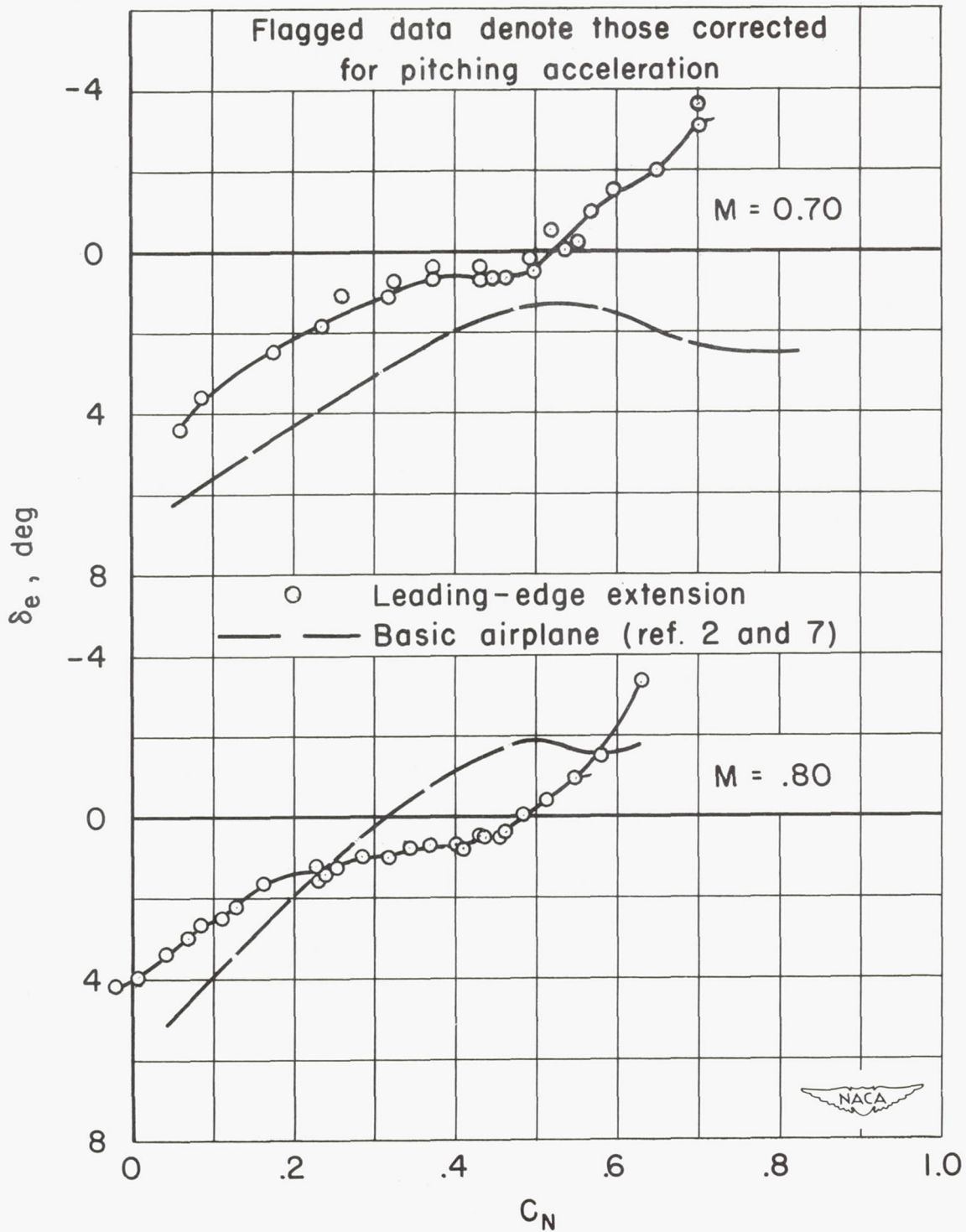

(b) M = 0.70 and 0.80

Figure 5.- Continued.

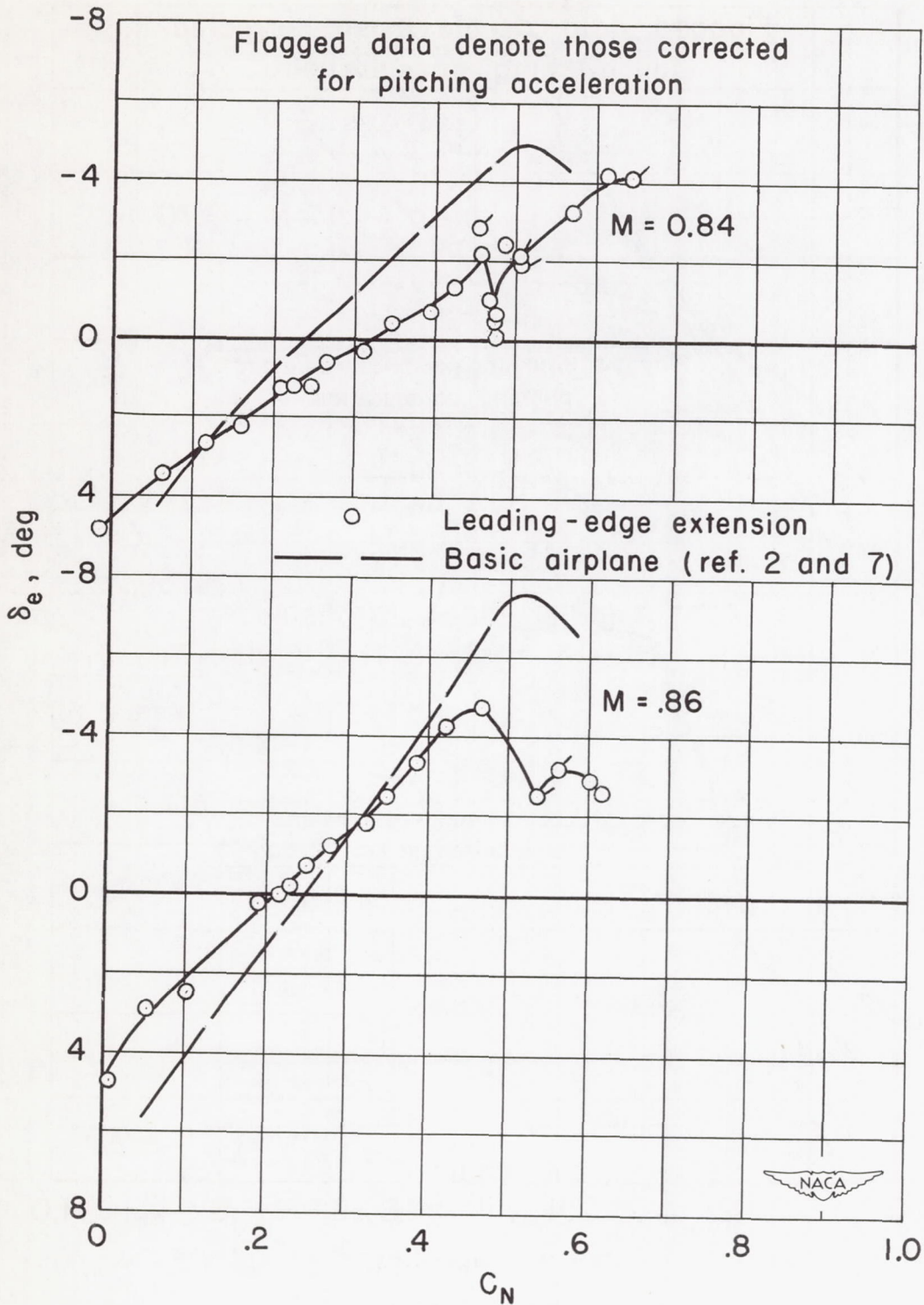

(c) $M = 0.84$ and 0.86

Figure 5.- Continued.

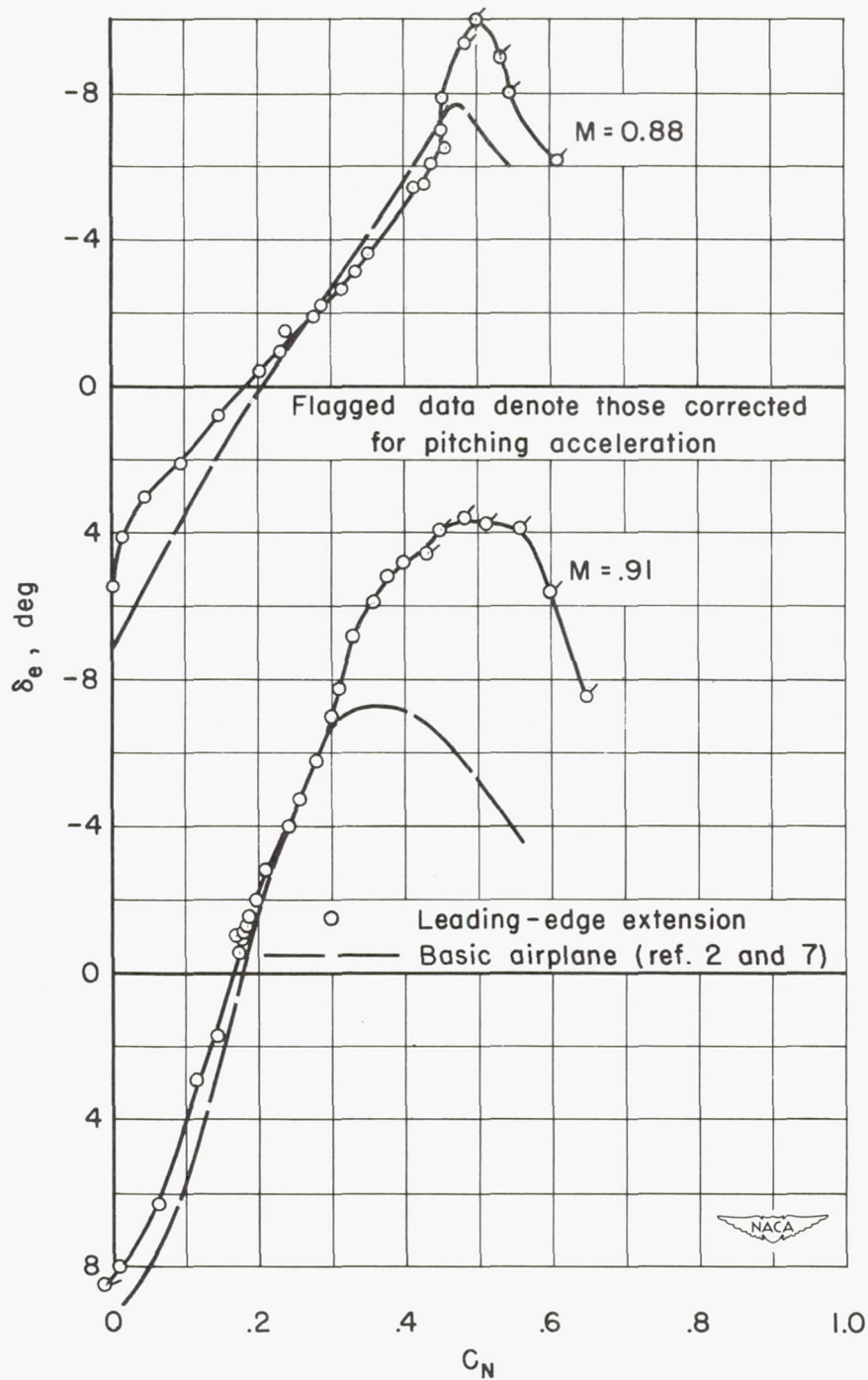

(d) M = 0.88 and 0.91

Figure 5.- Concluded.

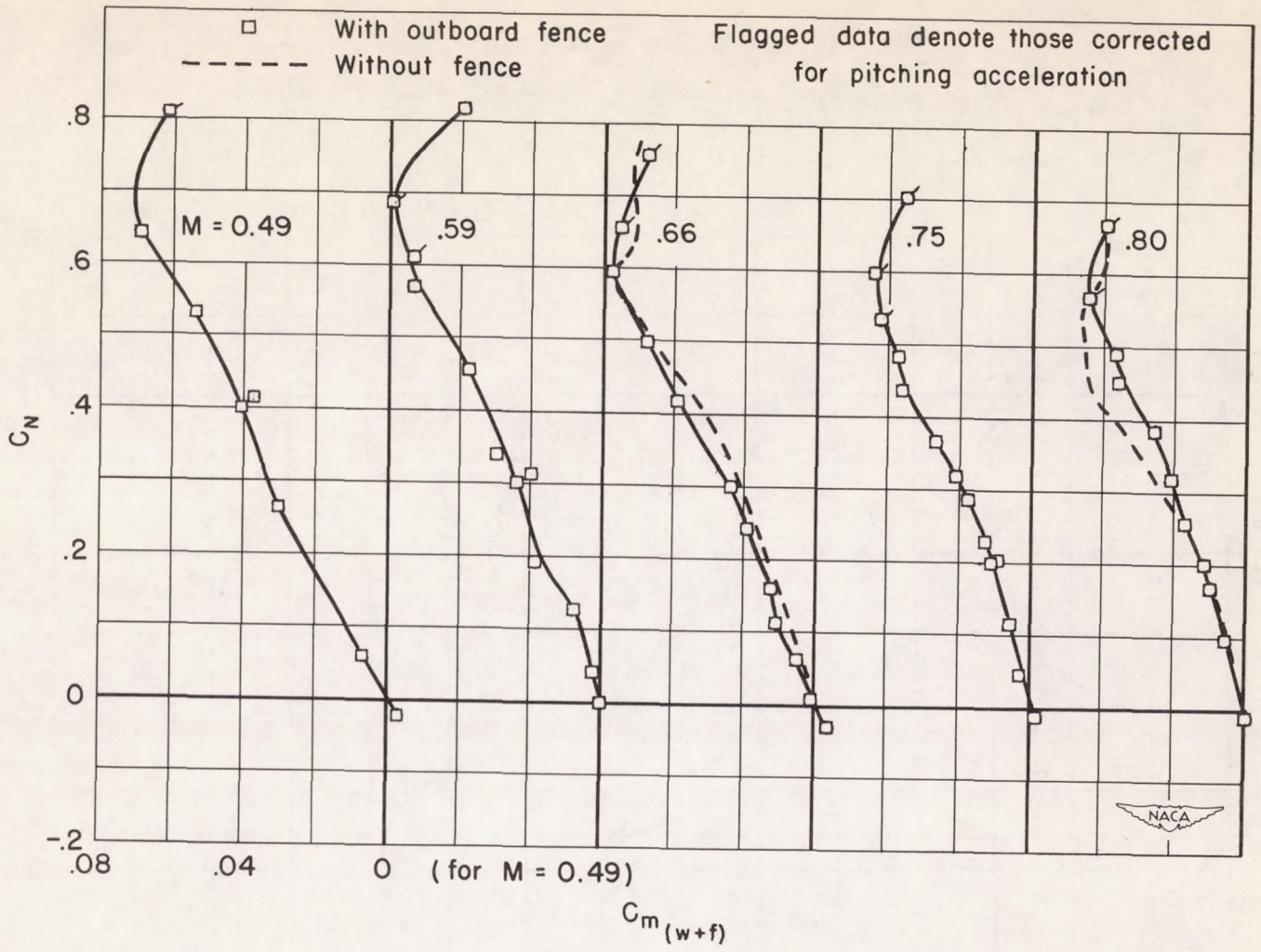

(a) $M = 0.49$ to 0.80

Figure 6.- Comparison of wing-fuselage pitching-moment curves for leading-edge extension and leading-edge extension with outboard fence; moment reference point $0.25 \bar{c}$.

CONFIDENTIAL

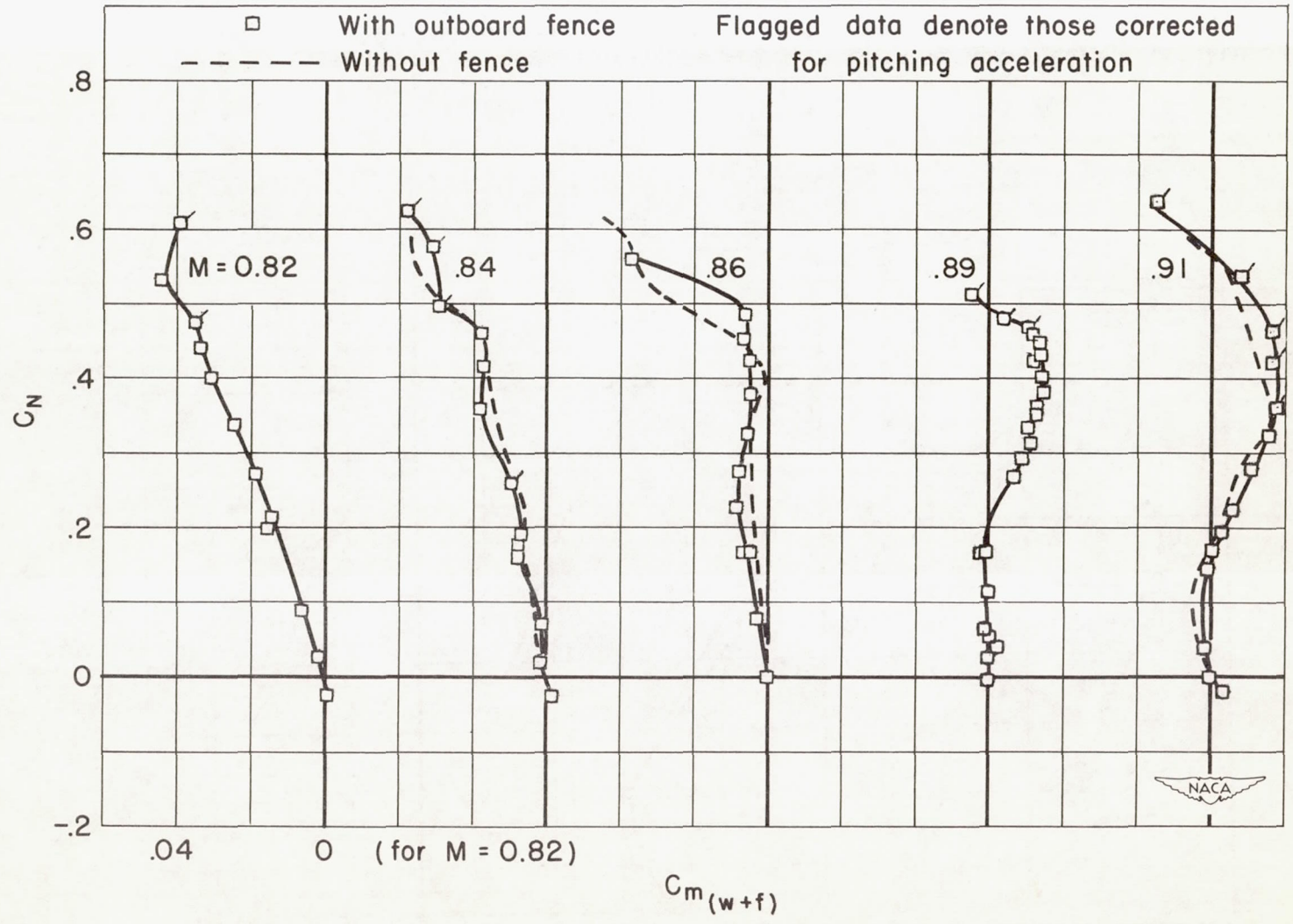

(b) M = 0.82 to 0.91

Figure 6.- Concluded.

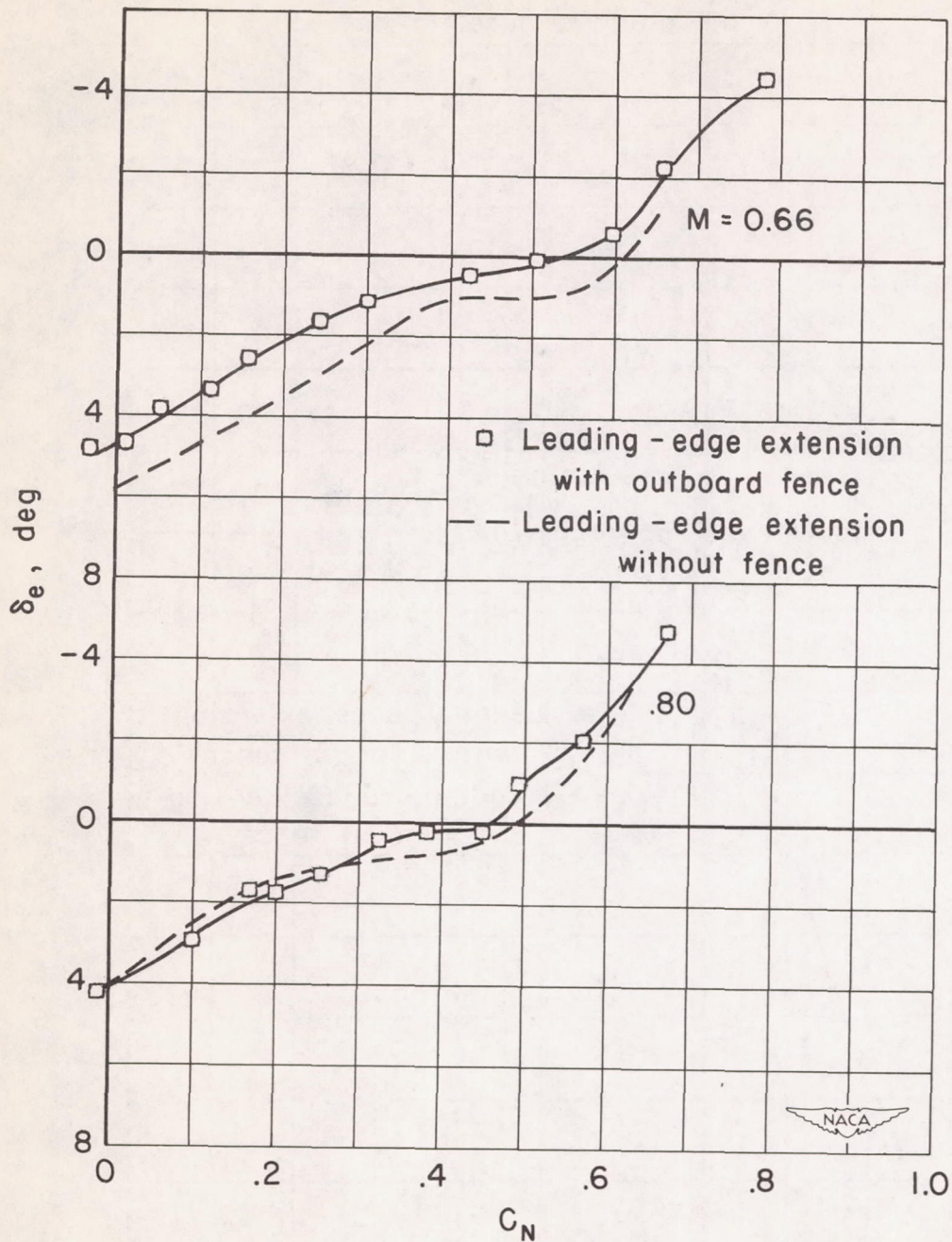

(a) $M = 0.66$ and 0.80

Figure 7.- Comparison of elevator angles with normal-force coefficient for leading-edge extension with and without fence; center of gravity 22.3 percent \bar{c} .

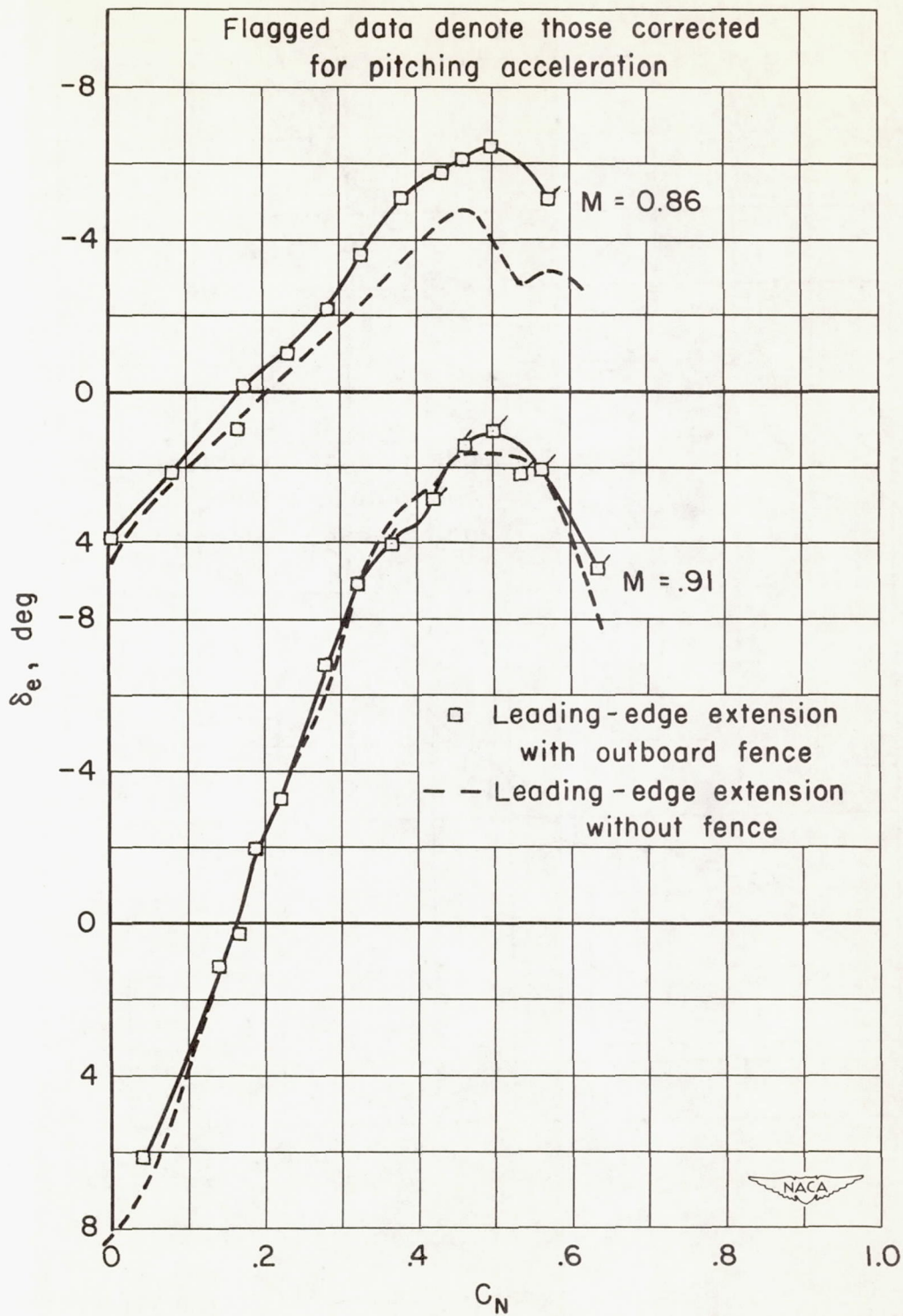

(b) $M = 0.86$ and 0.91

Figure 7.- Concluded.

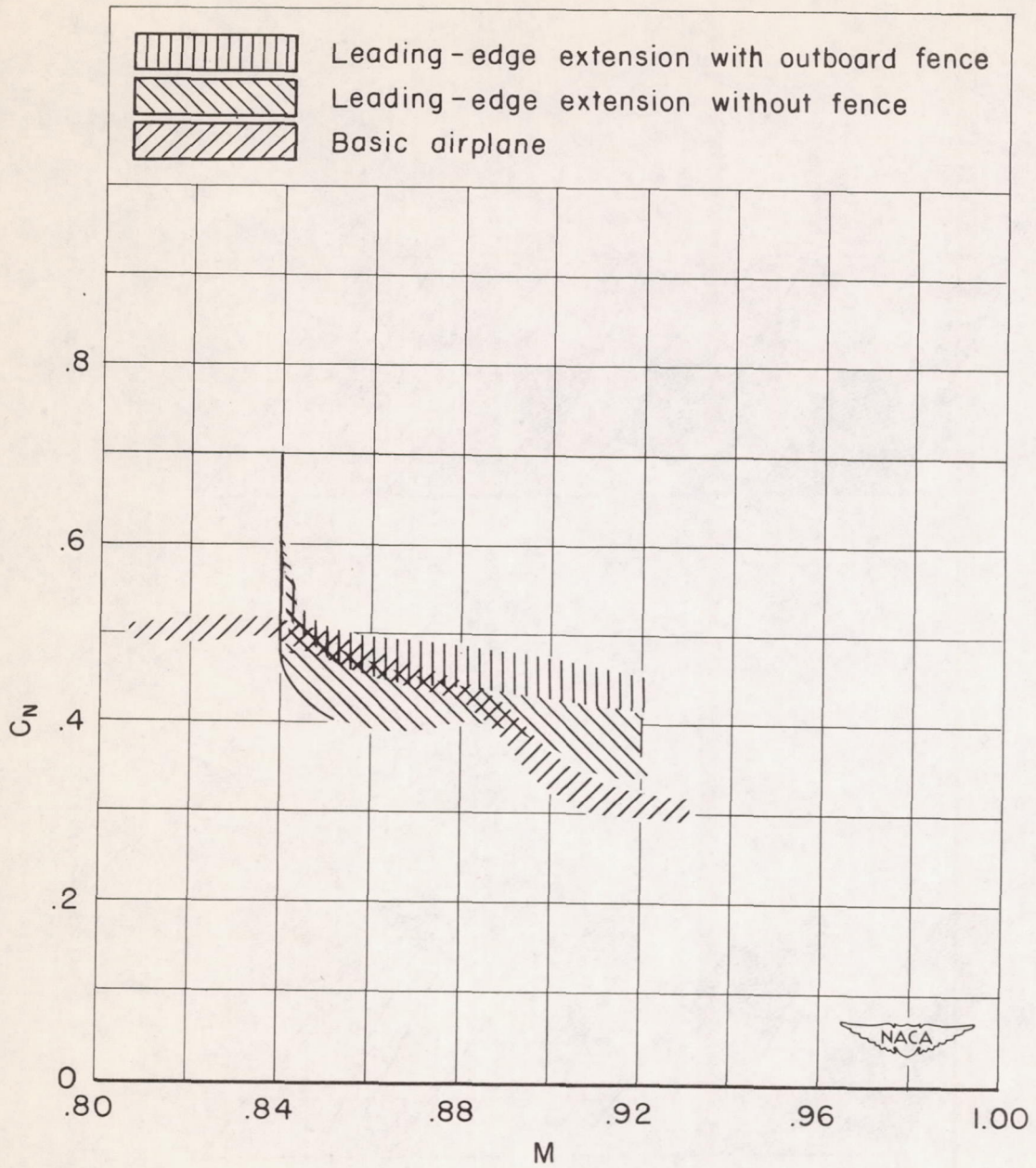
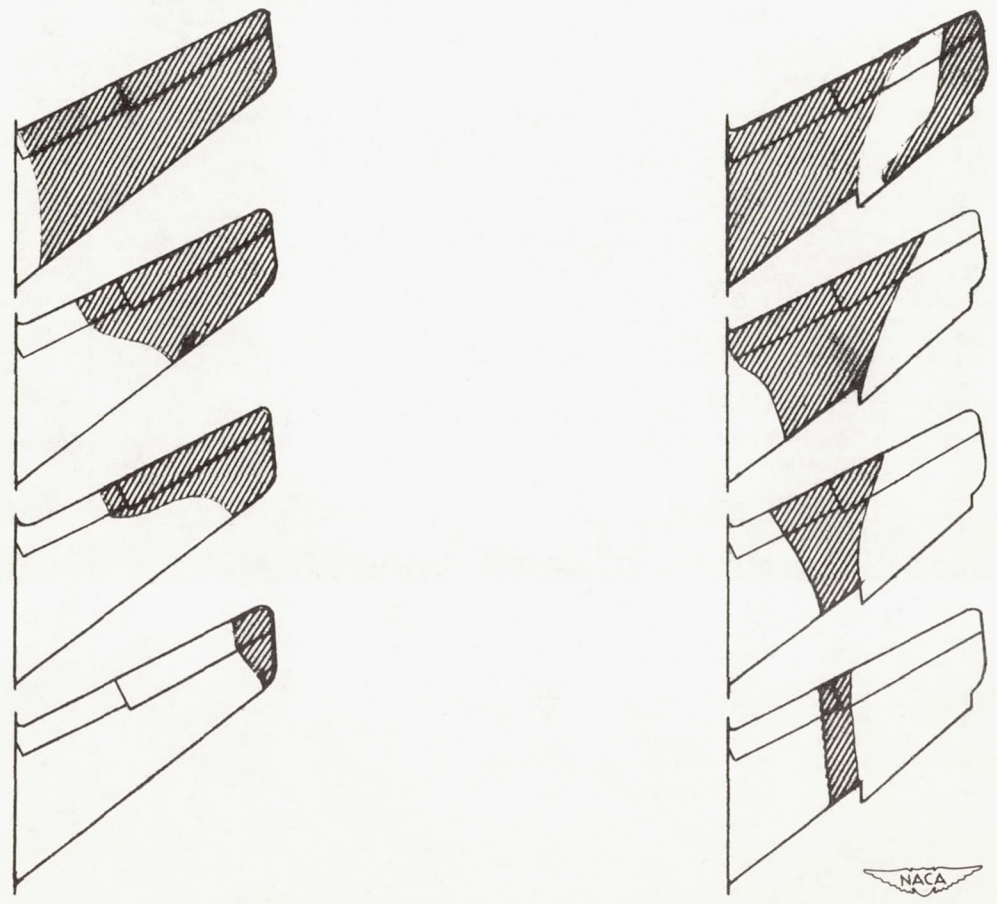

Figure 8.- Approximate pitch-up boundaries for three configurations.

Flow separation indicated by tufts



(a) Unmodified wing.

(b) Leading-edge extension.

Figure 9.- Comparison of stall progressions during the lg stall for the unmodified wing and wing with leading-edge extension.

CONFIDENTIAL

CONFIDENTIAL

NACA RM A54B26

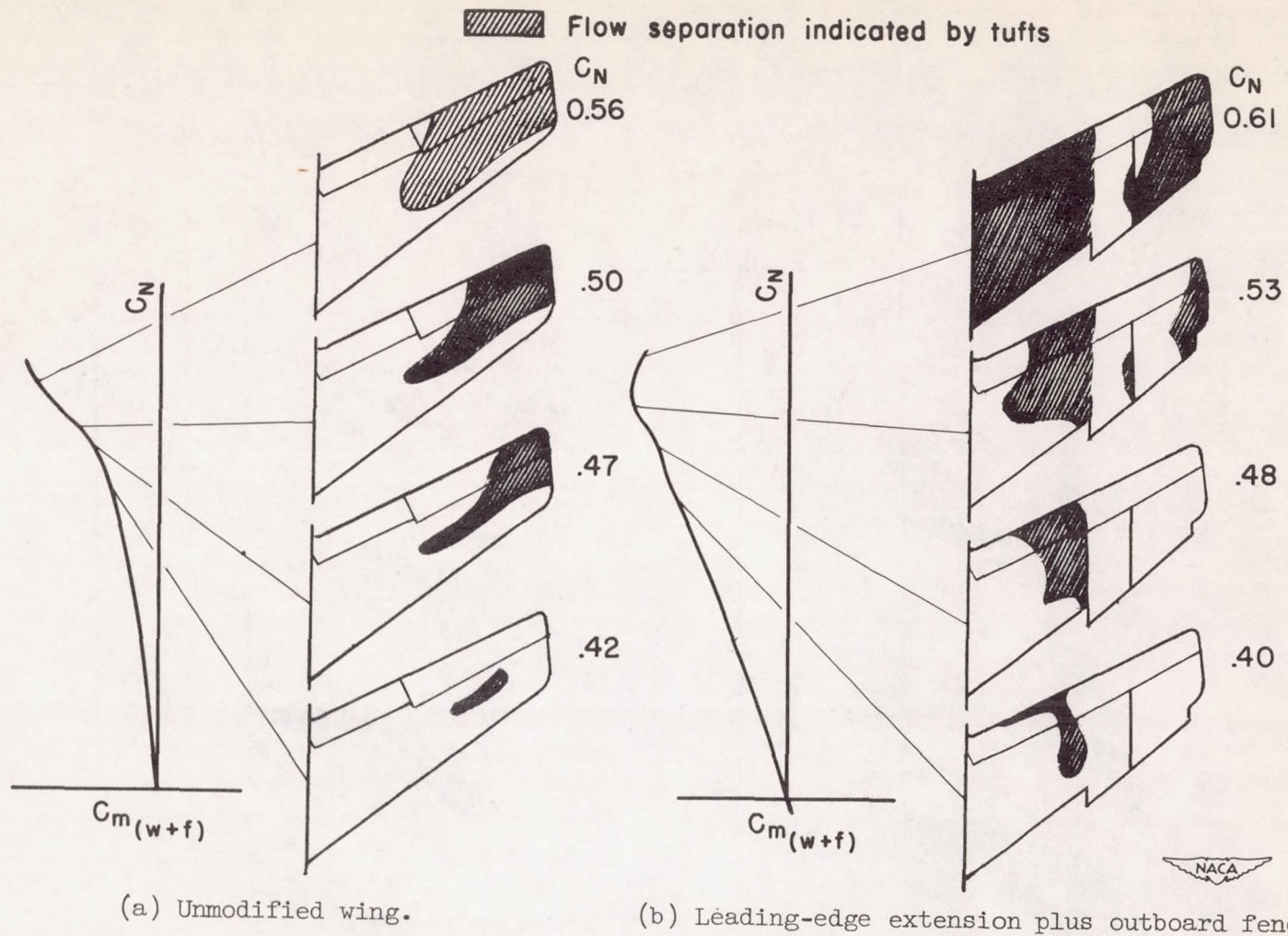
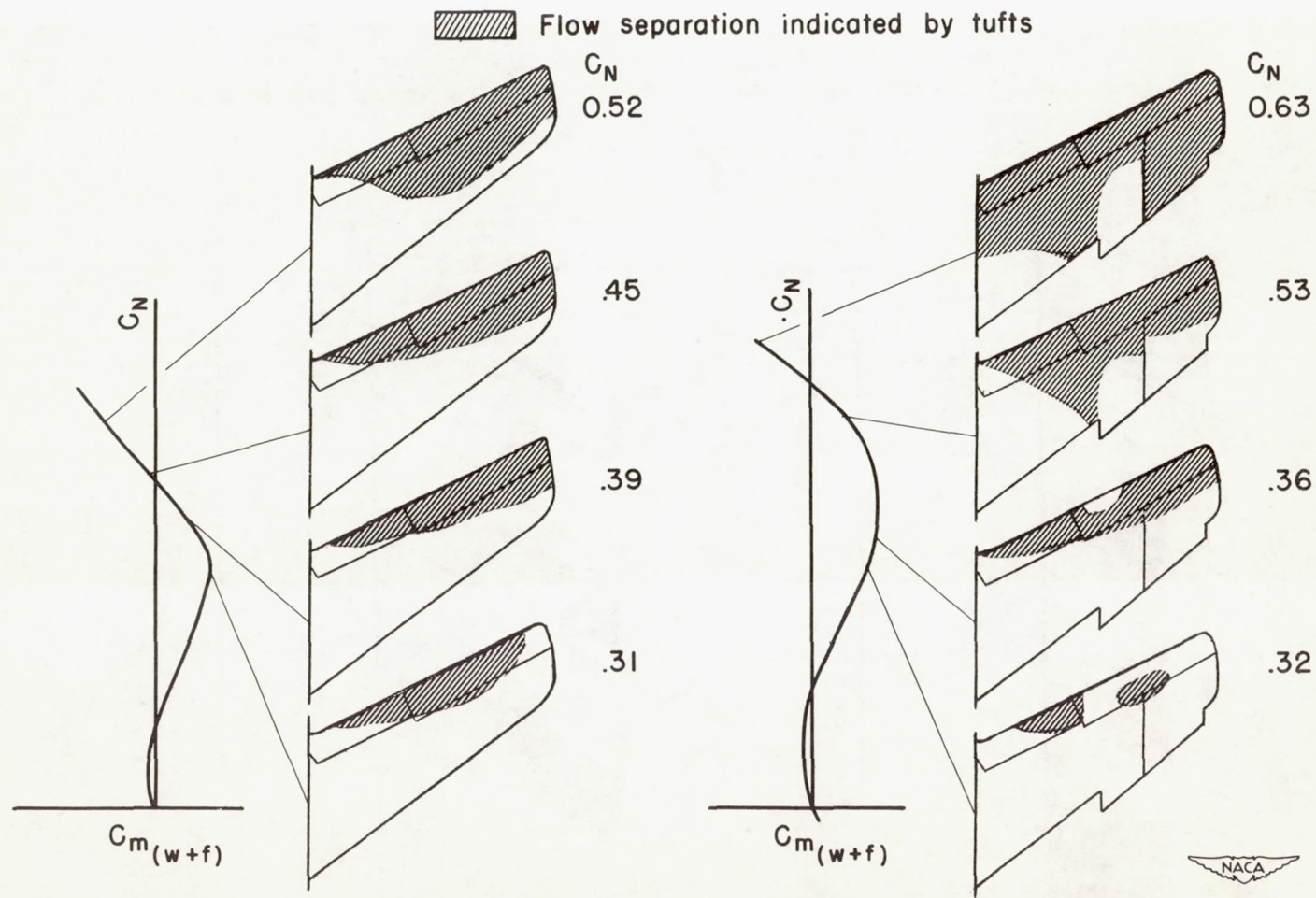

Figure 10.- Comparison of stall patterns for basic wing and wing with leading-edge extension and fence; $M = 0.82$.



(a) Unmodified wing.

(b) Leading-edge extension plus outboard fence.

Figure 11.- Comparison of stall patterns for the basic wing and wing with leading-edge extension and fence; $M = 0.90$ to 0.91 .

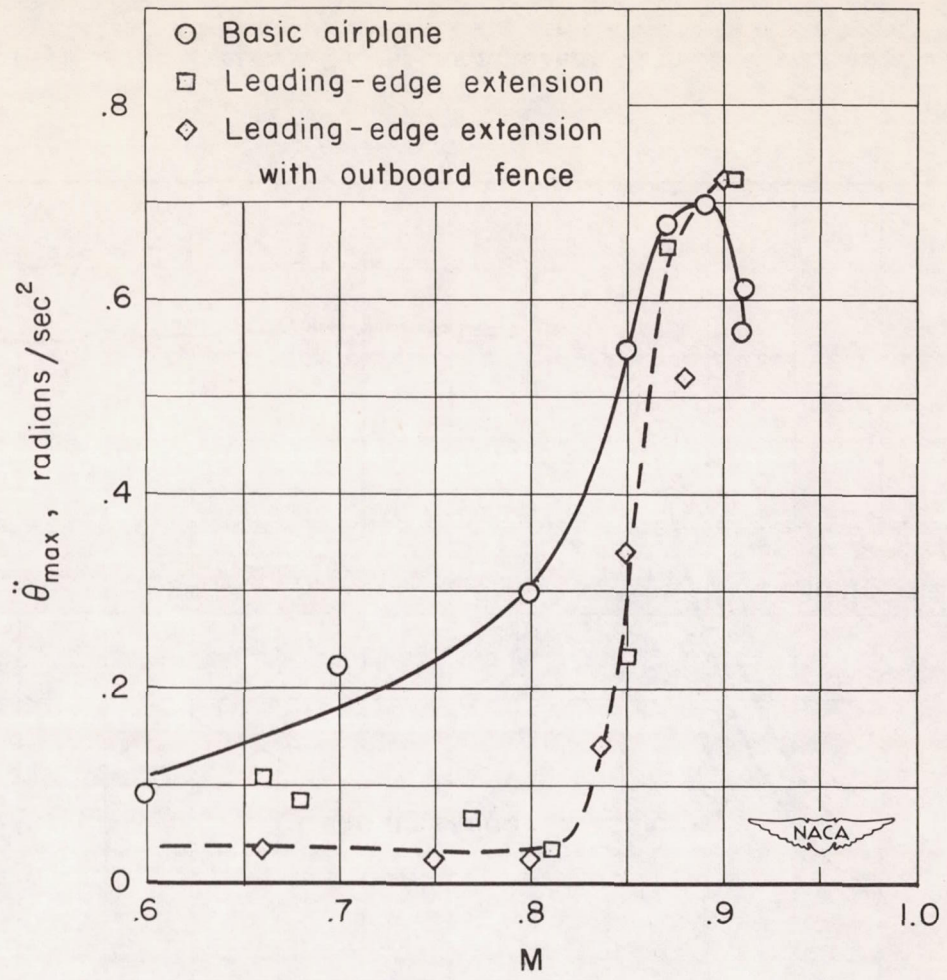

Figure 12.- Maximum pitching acceleration during stick-fixed pitch-ups.

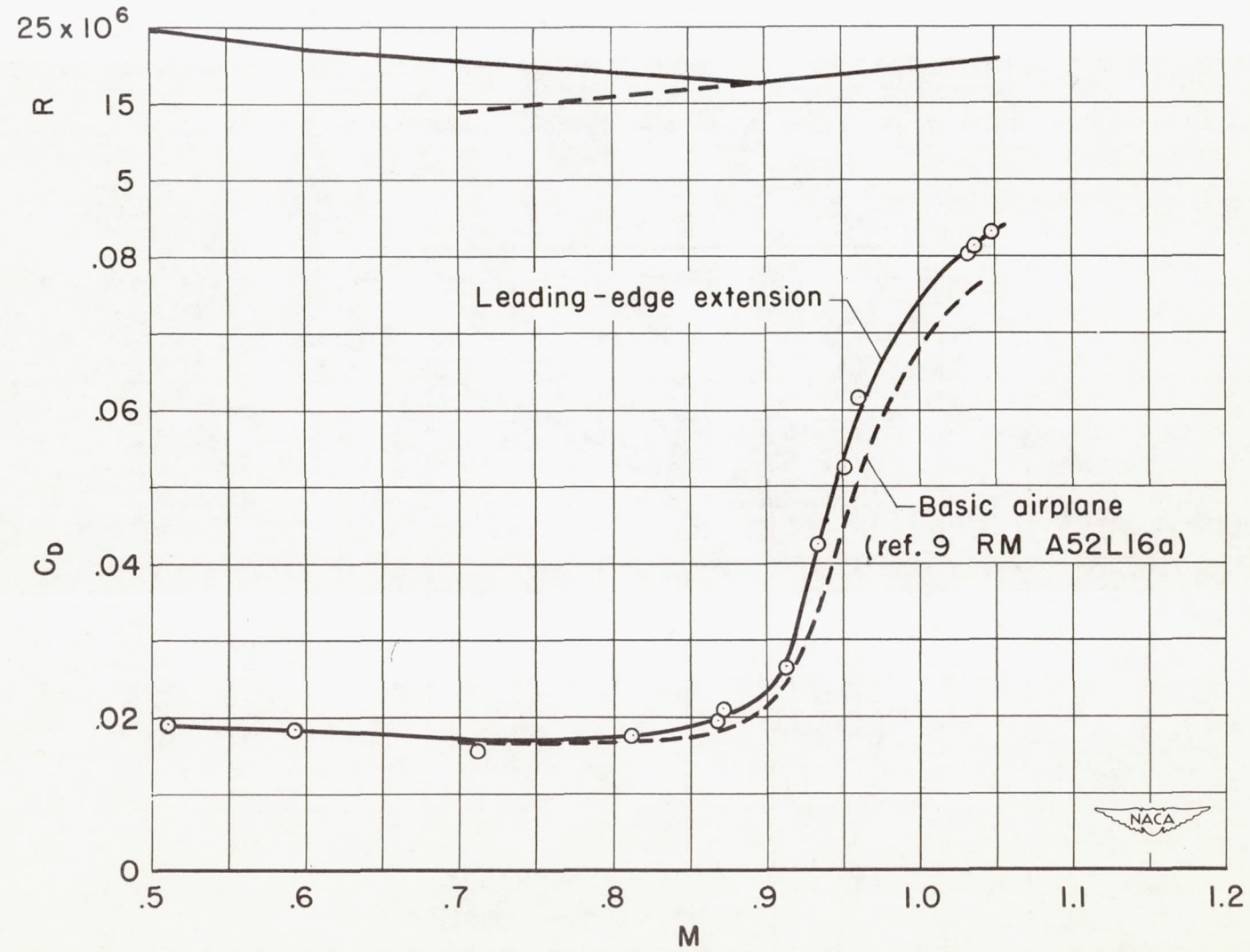

Figure 13.- Variation of drag coefficient with Mach number for C_N = 0.15.

CONFIDENTIAL

CONFIDENTIAL

CONFIDENTIAL