

RESEARCH MEMORANDUM

A DROP TEST FOR THE EVALUATION OF THE IMPACT
STRENGTH OF CERMETS

By B. Pinkel, G. C. Deutsch, and N. H. Katz

Lewis Flight Propulsion Laboratory
Cleveland, Ohio

NATIONAL ADVISORY COMMITTEE
FOR AERONAUTICS
WASHINGTON

March 15, 1955

NATIONAL ADVISORY COMMITTEE FOR AERONAUTICS

RESEARCH MEMORANDUMA DROP TEST FOR THE EVALUATION OF THE IMPACT
STRENGTH OF CERMETS

By B. Pinkel, G. C. Deutsch, and N. H. Katz

INTRODUCTION

CU-1

In the development of high temperature materials of the brittle category, the need to improve their impact strength for some applications has brought with it a demand for a simple machine for measuring impact resistance, both at room and elevated temperatures, and preferably one in which corrections such as the toss energy are negligible. This report describes such a machine and presents the results of some preliminary tests on the effect of temperature on impact strength of several alloys and cermets. A comparison is also given between the impact resistance of notched and unnotched specimens.

SPECIMEN SHAPE

Three types of specimens are being used. These are shown in figure 1. Bars A and B have been used in the initial NACA tests. Bar C has been suggested as a tentative standard at the Conference on the Impact Testing of Cermets, Alfred University, February 1954.

The surfaces of all bars are diamond ground using a 100 mesh resinoid bonded wheel so that the scratches are in a longitudinal direction.

APPARATUS

The apparatus is shown schematically in figure 2 and a photograph of the setup is shown in figure 3. The apparatus consists of the following:

(a) Specimen support. The vise is rigidly attached to a heavy table. The specimen is positioned (with the small radius up if the notched specimen is used) in the vise by means of a cut-out transite plate having the same thickness as the specimen (see inset fig. 2). A second transite plate, 1/4 inch thick, is located below the specimen to insulate it from

the vise. A nickel-plated copper (Lektromesh) screen is placed on top of the specimen and the 1/8 inch thick nickel sheet electrode is located over the screen. The purpose of the screen is to improve electrical contact.

(b) Temperature measurement and control. A thermocouple is spot welded on the underside (compression side) of the specimen near the jaw of the vise for unnotched specimens and in the center of the large radius notch for the notched bar. The temperature is indicated on a commercial potentiometer. To heat the bar the electrode is swung into contact with the free (unsupported) end of the test specimen. A small (approx. 1/2 x 1/2 in.) piece of copper electrical braid is placed between the electrode and the end of the specimen to improve electrical contact. A 3 KVA low voltage power source provides the heating current. This unit is controlled manually.

(c) Impacting hammer. The impacting hammer as it is used for cermets is shown in figure 4. The weight of this hammer is 0.190 pound. When materials are being evaluated which cannot be broken with this hammer, tungsten washers are placed on the shoulder of the hammer. When this is done the top washer is secured in place with a set screw to avoid any movement of the washers during the fall of the hammer. If additional weight is required an extension can be screwed into the hammer and additional washers added. The weight of the hammer has been increased to as much as 1.80 pounds by the addition of the extension and washers.

(d) Hammer support. The hammer is held by means of an electro-magnet which can be moved vertically on a scale $37\frac{1}{2}$ inches high. The hammer fits into a 1/16 inch deep recess in the core of the electro-magnet and this serves to position the hammer so that when it is dropped it strikes the specimen 1/8 inch from the free end and at the center of the specimen width.

EVALUATION PROCEDURE

(a) The specimen is positioned in the vise by means of the transite guide plates. The vise is closed "hand tight."

(b) The electrode is pressed against the free end of the specimen and the specimen is slowly heated to 25° F over the evaluation temperature and held for a few minutes to assure temperature equilibrium.

(c) The vise is retightened with a torque wrench to 20 inch-pounds.

(d) The electrode is withdrawn and after the specimen temperature has decreased to the desired evaluation temperature the hammer is dropped.

(e) If failure has not occurred, the specimen is reheated and the test is repeated by dropping the hammer from a slightly greater height. This procedure is repeated using successively increasing heights until fracture occurs. The steps are such as to yield an increment of energy of about 0.1 inch-pounds. The specimen is visually examined between hammer blows to detect cracking, and the specimen is considered to have failed if a crack is detected.

(f) The evaluation temperatures that have been used are room temperature, 1200°, 1500°, and 1750° F.

(g) The average of 6 specimens at each temperature is used as the impact strength.

(h) The impact energy which breaks the specimen and the largest energy which did not break the specimen are recorded as the test results.

COMPARATIVE DATA

Data for comparison purposes are shown in figure 5. These data were obtained on test bars A and B (see fig. 1) and each of the values listed is an average of 6 tests. The individual values generally did not vary from the average by more than ± 0.3 inch-pounds.

Lewis Flight Propulsion Laboratory
National Advisory Committee for Aeronautics
Cleveland, Ohio, February 15, 1955

SPECIMENS USED FOR NACA DROP IMPACT TEST

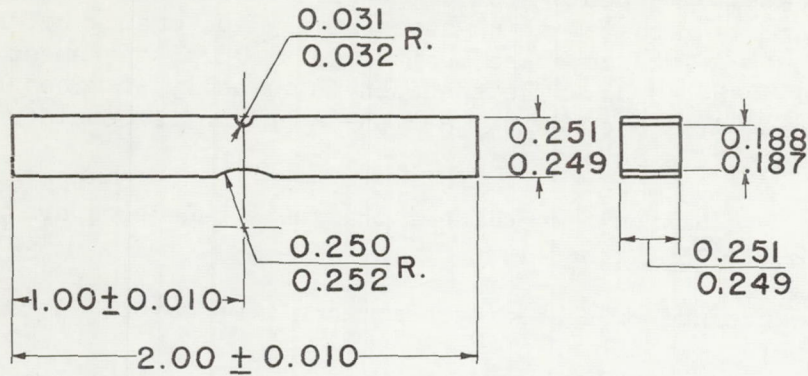

BAR A

NOTCHED IMPACT TEST BAR USED IN INITIAL TESTS

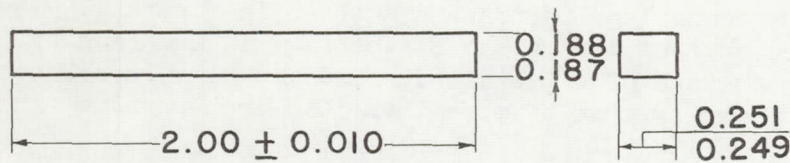

BAR B

UNNOTCHED IMPACT TEST BAR USED IN INITIAL TESTS

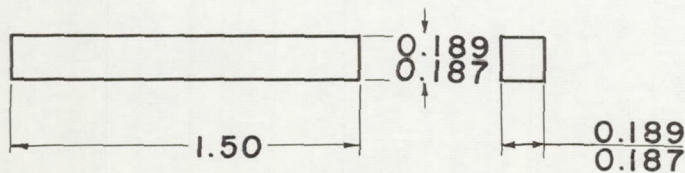

BAR C

TENTATIVE STANDARD IMPACT TEST BAR
 (SUGGESTED AT CERMET IMPACT CONFERENCE,
 ALFRED U., FEB. 1954)

CS-9027

FIGURE 1 - IMPACT SPECIMENS

SCHEMATIC VIEW OF NACA DROP IMPACT TEST

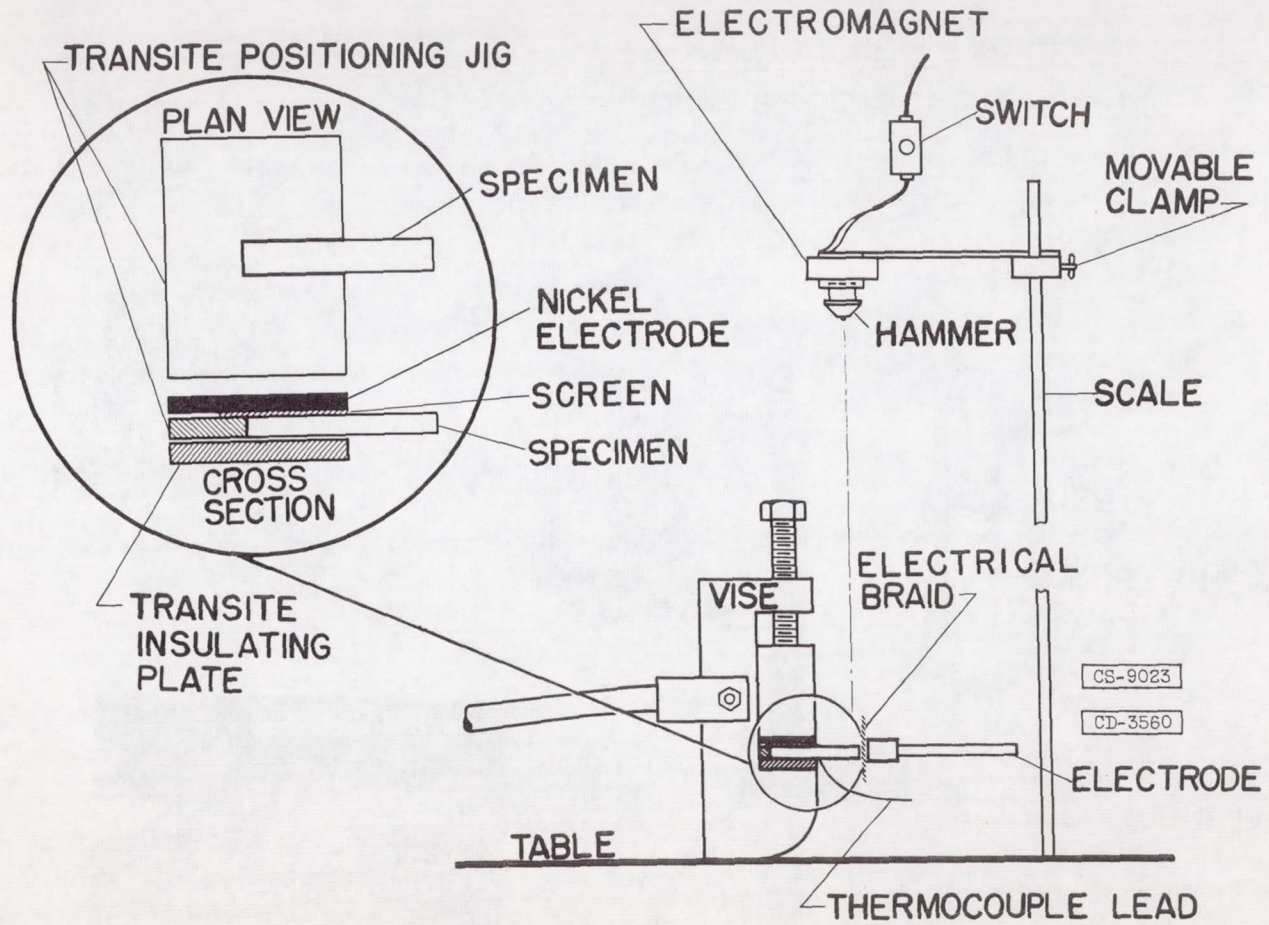

FIGURE 2 - SCHEMATIC VIEW OF NACA IMPACT DROP TEST

DROP IMPACT TEST SET-UP

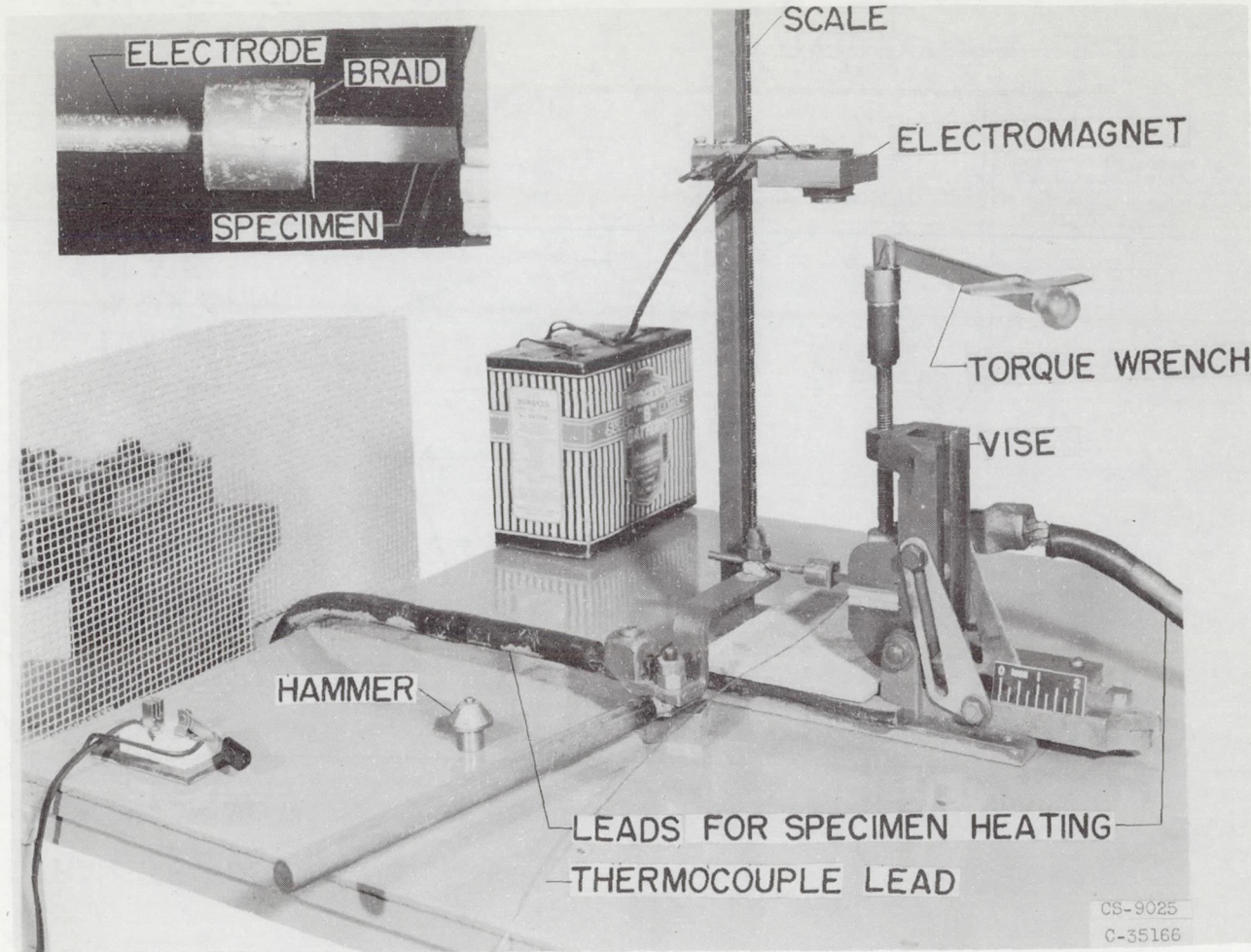
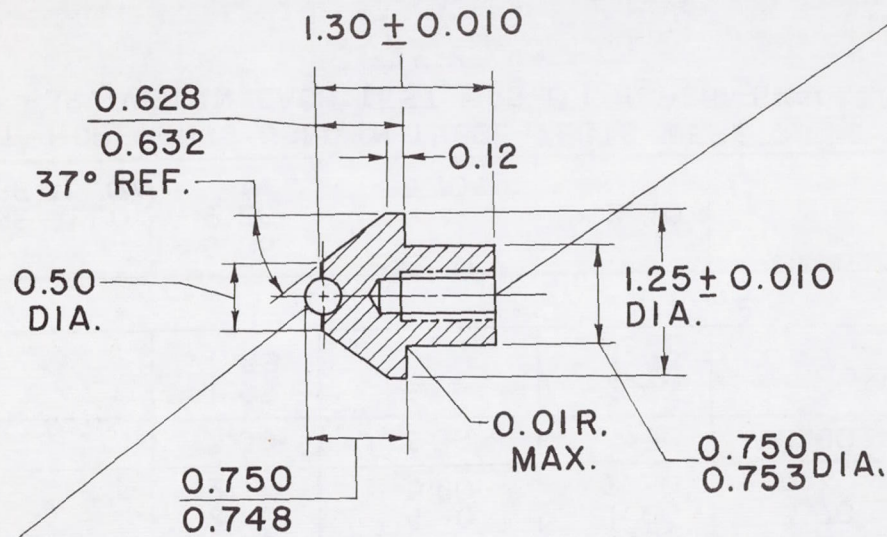

FIGURE 3 - IMPACT DROP TEST SET-UP

DRILL "Q" (0.3320)
DEPTH 0.89 - 0.98
C'SINK 90° TO 0.38 - 0.40 DIA.
TAP 3/8-24 NF-3
DEPTH 0.56 - 0.68



0.250 DIA. STEEL BALL
TO BE PRESSED
FIT INTO 1/4 DIA.
SPHERICAL CAVITY.

FIGURE 4 - IMPACT DROP TEST HAMMER

MATERIAL	AVERAGE IMPACT STRENGTH, (IN.-LB)					
	ROOM TEMPERATURE		1200° F		1500° F	
	NOTCHED (BAR A)	UNNOTCHED (BAR B)	NOTCHED (BAR A)	UNNOTCHED (BAR B)	NOTCHED (BAR A)	UNNOTCHED (BAR B)
CERMETS						
K 150B	1.30		1.05			
K 152B	2.10	4.10	1.60	3.70	1.60	
K 154B	2.80	5.20	2.30	5.20	2.30	5.50
K 162B	3.30	6.30	1.30	2.60		
FS-9	1.93		2.43		2.52	
FS-27	1.29		1.45		1.34	
ALLOYS						
X-40	48.05					
NEW CAST Co BASE ALLOY	2.20		2.10		2.10	
NEW CAST Ni BASE ALLOY		16.70				

NOTE: THE IMPACT INCREMENTS USED IN THESE TESTS WERE 0.1 IN.-LB., HENCE, THE HIGHEST IMPACT ENERGY SURVIVED IN EACH TEST WAS 0.1 IN.-LB. SMALLER THAN THE VALUES LISTED ABOVE.

FIGURE 5 - NACA DROP TEST IMPACT DATA