

UNCLASSIFIED

RM E53J13
Copy 65

RM E53J13

NACA RM E53J13



GROUP 4
Downgraded at 3 year
intervals; declassified
after 12 years

RESEARCH MEMORANDUM

PUMPING AND THRUST CHARACTERISTICS OF SEVERAL DIVERGENT
COOLING-AIR EJECTORS AND COMPARISON OF PERFORMANCE
WITH CONICAL AND CYLINDRICAL EJECTORS

By S. C. Huntley and Herbert Yanowitz

Lewis Flight Propulsion Laboratory
Cleveland, Ohio

CASE
COPY FILE

JET PROPULSION LABORATORY
LIBRARY

JAN 26 1954

CALIFORNIA INSTITUTE OF TECHNOLOGY

Classification Changed to UNCLASSIFIED	Authority DOD DIR. 5200.10	By N. Devereux/UM
	Date MAR 26 1966	



NATIONAL ADVISORY COMMITTEE FOR AERONAUTICS

WASHINGTON
January 20, 1954

UNCLASSIFIED

UNCLASSIFIED



NATIONAL ADVISORY COMMITTEE FOR AERONAUTICS

RESEARCH MEMORANDUM

PUMPING AND THRUST CHARACTERISTICS OF SEVERAL DIVERGENT

COOLING-AIR EJECTORS AND COMPARISON OF PERFORMANCE

WITH CONICAL AND CYLINDRICAL EJECTORS

By S. C. Huntley and Herbert Yanowitz

Classification Changed to UNCLASSIFIED		Authority	
DOD DIR. 5200.10		By N. Devereux	
MAR 26 1966			

SUMMARY

An investigation was made of the performance of four divergent ejector configurations having shroud-exit to primary-nozzle-exit diameter ratios of 1.2 and 1.3 with minimum-shroud to primary-nozzle-exit diameter ratios of 1.1 and 1.2, respectively. For both exit-diameter ratios, spacing ratios of 0.87 and 1.6 were investigated.

A comparison of the performance of conical, cylindrical, and divergent ejectors showed that on the basis of similar design variables (exit-diameter ratio and spacing ratio) each configuration has merit. At an exit-diameter ratio of 1.2 and spacing ratios of 0.9 and 1.6, the divergent ejector had the highest thrust at zero secondary flow. With corrected weight-flow ratios of 0.03 and 0.07, the divergent ejector had the highest thrust at low primary pressure ratios, while the cylindrical ejector had the highest thrust at high primary pressure ratios. The range of primary pressure ratio over which the cylindrical ejector was advantageous in thrust increased for both the higher corrected weight-flow ratio and the larger spacing ratio. The conical ejector, however, can pump a given corrected weight flow over a wider range of primary pressure ratio but at the expense of a relatively low ejector thrust. The divergent ejector had the smallest range of primary pressure ratio for a given corrected weight-flow ratio.

The possibility of obtaining ejector thrust performance from a simple one-dimensional equation and from a measurement of wall pressure distribution was illustrated by the good agreement between measured and calculated thrust.

INTRODUCTION

The jet ejector is a simple device that is being widely used to pump cooling air. It has been shown (ref. 1) that when an ejector is

UNCLASSIFIED

2912
T-1

used to pump cooling air through an annular passage surrounding an afterburner, thrust increases over the basic engine with a simple conical exhaust nozzle may be obtained. At the present, the NACA is conducting a research program to investigate the performance of model and full-scale jet ejectors. Previous reports have presented data for model conical ejectors (refs. 2 to 5), cylindrical ejectors (refs. 6 and 7), and double-shroud ejectors (refs. 8 and 9).

It was shown (ref. 6) that ejector shape (conical versus cylindrical) has an effect on the pumping and thrust characteristics. As part of a continuing program to investigate the performance of ejectors, several divergent ejectors were tested at the NACA Lewis laboratory, and the data obtained are presented herein. The divergent ejectors differ from the conical and cylindrical in that mixing of the primary and secondary streams occurs in a region of increasing area as opposed to decreasing area for a conical ejector and constant area for a cylindrical ejector. This difference in available flow area may lead to better pumping or thrust characteristics, or both. Also, the divergent ejector results in small areas around the primary jet nozzle, which may be desirable because of the increased velocity of cooling-air flow and hence greater heat transfer from wall to cooling air. A small area around the primary jet nozzle may, however, lead to a high pressure drop if the passage contains nozzle actuators, for instance, instead of being smooth.

Four divergent ejectors were investigated. The ejectors were operated over a range of primary pressure ratio from 1.0 to 10 at zero secondary flow and at constant values of secondary pressure ratio from 0.40 to 4.0. The temperature of both the primary and secondary air streams was approximately 80° F. The pumping and thrust characteristics are presented as a function of primary pressure ratio for several values of corrected weight-flow ratio from zero to 0.10.

The pumping and thrust characteristics of the divergent ejectors are compared with the conical and cylindrical ejectors on a basis of similar design variables. The effect of wall pressure on the ejector thrust is also discussed.

APPARATUS AND PROCEDURE

The nomenclature for the divergent-ejector investigation is presented in figure 1, and a diagram of the model setup is schematically shown in figure 2. The apparatus, instrumentation, and procedure are the same as described in reference 4, except, of course, for the change in ejector-shroud geometry. The secondary pressure and temperature-measuring station for the divergent ejector was $4\frac{1}{2}$ inches upstream

of the primary-nozzle exit. The conical primary nozzle and shroud had half-cone angles of 8° with 5- and 10-inch-inside-diameter approach pipes, respectively. The corrected weight-flow ratio and ejector thrust ratio used to generalize the experimental data were based on experimentally measured values of primary jet nozzle weight flow and thrust. The discharge and thrust coefficients of the primary nozzle are presented in figure 3 to indicate the correction necessary to obtain agreement between measured and ideal values of primary-nozzle weight flow and thrust.

Descriptive dimensions of the various divergent-ejector configurations investigated are given in the following table:

Ejector	Minimum-diameter ratio, D_m/D_p	Exit-diameter ratio, D_e/D_p	Spacing ratio, L/D_p	Divergence angle, α , deg
1	1.11	1.21	0.867	3.88
2	1.11	1.20	1.63	1.72
3	1.21	1.31	.874	3.82
4	1.20	1.31	1.63	1.95

The performance of each configuration was investigated over a range of primary pressure ratio from 1.0 to approximately 10 at zero secondary flow and at constant values of secondary pressure ratio from 0.40 to 4.0. The temperature of both the primary and secondary air streams was approximately 80° F.

RESULTS AND DISCUSSION

Divergent-Ejector Performance

Pumping characteristics. - The experimental pumping characteristic data of the four divergent ejectors are presented in figure 4 for constant values of secondary pressure ratio from 0.40 to 4.0. Experimental data for zero secondary flow and curves for corrected weight-flow ratios from 0.01 to 0.10 (obtained from a cross plot of the data shown in fig. 4) are presented in figure 5. The performance trends shown are generally similar to the previously reported trends of the conical and cylindrical ejectors. At zero secondary flow, the secondary pressure ratio P_s/p_0 decreased as the primary pressure ratio P_p/p_0 increased, until a minimum value of P_s/p_0 was reached. The value of P_p/p_0 at which the $(P_s/p_0)_{\min}$ was obtained indicates the point at

which the shroud became "choked," and the ratio of P_s/p_0 to P_p/p_0 becomes constant (constant slope) with a further increase in P_p/p_0 . Similar trends are observed for various secondary flow rates; however, the $(P_s/p_0)_{\min}$ obtained at a given value of corrected weight-flow ratio increased with increasing weight-flow ratio.

Inspection of the curves presented in figure 5 shows that the value of P_p/p_0 at which the $(P_s/p_0)_{\min}$ was obtained differs considerably for the several configurations and also is dependent on the value of corrected weight-flow ratio. In addition, at a constant value of corrected weight-flow ratio, the P_s/p_0 obtained at a given value of P_p/p_0 is dependent on the configuration. For the configurations tested, the ejector having a smaller exit diameter and longer spacing (smaller divergence angle) obtained the lowest P_s/p_0 at low values of P_p/p_0 for a given corrected weight-flow ratio, while the ejector with the larger exit diameter and shorter spacing (larger divergence angle) obtained the lowest P_s/p_0 at high values of P_p/p_0 . Consequently, the selection of a suitable ejector for a particular cooling requirement will necessitate consideration of the effect of ejector configuration and also of the primary pressure ratio range anticipated on the desired pumping characteristics.

Thrust characteristics. - The experimental thrust-characteristic data of the four divergent ejectors are presented in figure 6 for zero secondary flow and for constant values of P_s/p_0 from 0.40 to 4.0. Cross plots of the data of figure 6 are presented in figure 7 for corrected weight-flow ratios from zero to 0.10. The thrust-performance trends exhibited by the divergent ejectors are similar to those of the conical and cylindrical ejectors previously reported (refs. 2 to 9). In general, the minimum ejector thrust ratio occurred at the P_p/p_0 corresponding to the point of $(P_s/p_0)_{\min}$. As P_p/p_0 was increased above that required for the $(P_s/p_0)_{\min}$, the ejector thrust ratio increased rapidly up to primary pressure ratios of about 5 (at low weight-flow ratios), probably as the result of less overexpansion of the primary and secondary streams within the shroud. At high primary pressure ratios, the ejector thrust ratio increased at a much slower rate, which indicates that perhaps the flow within the shroud was becoming stabilized. The thrust ratio of the ejectors increased, of course, with increasing secondary flow.

Inspection of the curves presented in figure 7 shows that for a given corrected weight-flow ratio the ejectors with shorter spacing (larger divergence angle) generally had a higher thrust at any value of

primary pressure ratio than those of the same exit-diameter ratio but with longer spacing. On the other hand, the ejectors with a smaller exit diameter had higher thrust at intermediate values of P_p/p_0

than those of the same spacing but with larger diameters, while the ejectors with larger diameters had higher thrust at either low or high P_p/p_0 .

The ejector thrust ratio is another factor to be considered in the selection of a suitable ejector for a particular cooling requirement. A low P_s/p_0 was not conducive to high thrust for any of the configurations tested, except for the ejector with a large exit diameter and short spacing. However, the low P_s/p_0 and high thrust for the ejector with a large exit diameter and short spacing occurred at only high values of P_s/p_0 . Consequently, ejector thrust ratio, generally, must be compromised with the values of P_s/p_0 desired to pump a given corrected weight-flow ratio; and, as in the consideration of pumping characteristics, the choice of configuration may be governed to some extent by the design range of primary pressure ratio.

Comparison of Ejectors

A comparison of the performance of conical, cylindrical, and divergent ejectors on a basis of similar design variables (exit-diameter ratio D_e/D_p and spacing ratio L/D_p), wherein the merits of each configuration will be governed mainly by internal-flow characteristics, should give an indication of the influence of shroud geometry on the mixing and expansion processes. The pumping characteristics of cylindrical ejectors have been compared quantitatively with an idealized flow, and good agreement between theory and experimental data was obtained (ref. 7). A similar comparison between conical, cylindrical, and divergent ejectors is not as simple because of the influence of wall pressure on the conservation of momentum between the primary nozzle (shroud inlet) and the shroud exit and the fact that a rational method of deriving wall pressure distribution along the length of shrouds is not presently available for all ejectors and operating conditions. A qualitative comparison of idealized flows will be used, however, to explain trends in the experimental data, and the effect of wall pressure on ejector thrust will be discussed. The geometries of ejectors having the same D_e/D_p and L/D_p are compared in figure 8. The divergent ejector has the smallest available flow area within the shroud, and the conical ejector, the largest. Furthermore, the effects of an increase in L/D_p on the ejector geometry are (1) to lengthen the cylindrical shroud, (2) to make the divergent ejector approach the cylindrical with a slight decrease in available flow area, and (3) to make the conical

ejector depart further from both the cylindrical and divergent ejectors, with a relatively large increase in available flow area.

Pumping characteristics. - A comparison of the experimental pumping characteristics of conical, cylindrical, and divergent ejectors with a D_e/D_p of 1.2 is presented in figure 9 for L/D_p 's of 0.9 and 1.6. Curves are presented for corrected weight-flow ratios of zero, 0.03, and 0.07. As expected from geometrical considerations, the divergent ejector (having the smallest flow area available) had the lowest value of P_p/p_0 wherein a stabilized primary supersonic flow was first obtained (as indicated by the attainment of a constant ratio of P_s/p_0 to P_p/p_0), and the conical ejector had the highest value in all cases.

At zero secondary flow and L/D_p of 0.9 (fig. 9(a)), the divergent ejector had the lowest and the conical the highest P_s/p_0 over the entire range of P_p/p_0 . The divergent ejector generally should have the highest P_s/p_0 , because it allows the least amount of free expansion; but, apparently, with this L/D_p the close proximity of the divergent shroud to the expanding primary stream became a governing factor, and large shear forces caused an increase in the extent of free expansion with a subsequent decrease in P_s/p_0 . An increase of L/D_p to 1.6 (fig. 9(b)), which decreased the P_p/p_0 required for stabilized flow (minimum P_s/p_0) of both the cylindrical and divergent ejectors but had no effect on the conical ejector, is indicative of the effect of increased L/D_p on the extent of primary stream expansion. The increased L/D_p increased the P_s/p_0 of the conical ejector, decreased that of the divergent, but did not affect that of the cylindrical; these effects resulted in more nearly equal values of $(P_s/p_0)_{min}$ for the cylindrical and divergent ejectors than for the conical ejector. This is in accord with the effect of an increasing L/D_p on the flow area available in the shrouds. At the longer L/D_p , the decreased flow area available was detrimental to the divergent ejector in attaining a relatively low value of P_s/p_0 , and, as a result, the cylindrical ejector had the lowest P_s/p_0 at a P_p/p_0 above about 2.

With secondary flow, mixing of the two streams and less primary expansion resulted in a higher P_s/p_0 for all shrouds, and the relative increase in P_s/p_0 at a given corrected weight-flow ratio corresponded to the relative amount of flow area available. The conical ejector with the most flow area available generally had the lowest P_s/p_0 and

consequently can pump a given corrected weight-flow ratio over a wider range of P_p/p_0 . The divergent ejector with the least flow area available and the lowest resultant extent of primary stream expansion became choked at the lowest value of P_p/p_0 for a given corrected weight-flow ratio and subsequently had the least pumping ability. The effect of an increase in corrected weight-flow ratio from 0.03 to 0.07, which resulted in a decrease in primary stream expansion and a subsequent lower primary Mach number for choked flow, decreased the pumping range of P_p/p_0 for all ejectors. The conical ejector having the largest flow area available was affected the least by an increase in corrected weight-flow ratio. Increasing L/D_p from 0.9 to 1.6 (figs. 9(c) to (f)) resulted in a lower P_s/p_0 for all ejectors at low values of P_p/p_0 , while at high values of P_p/p_0 , there resulted no change in P_s/p_0 for the cylindrical ejector, an increase in that for the divergent, and a decrease in that for the conical. Again, the effect of an increase in L/D_p is a result of the change in flow area available for expansion of the primary stream. As a result of the relatively large increase in flow area of the conical ejector at the increased L/D_p , the cylindrical ejector had a lower P_s/p_0 at P_p/p_0 less than 2.6 and a corrected weight-flow ratio of 0.03 (fig 9(d)). Evidently with a large flow area available, overexpansion of the primary stream became a governing factor in the performance of the conical ejector at the low corrected weight-flow ratio.

Thrust characteristics. - A comparison of the experimental thrust characteristics of conical, cylindrical, and divergent ejectors with an exit-diameter ratio of 1.2 is presented in figure 10 for spacing ratios of 0.9 and 1.6 and corrected weight-flow ratios of zero, 0.03, and 0.07. At zero secondary flow, the ejector thrust ratio of the divergent ejector is highest and the ejector thrust ratio of the conical is lowest at P_p/p_0 above the minimum required for the expanding primary stream to just fill the shroud exit (figs. 10(a) and (d)). The difference in efficiency of primary stream expansion accounts for the difference in ejector thrust ratio. Increasing the L/D_p from 0.9 to 1.6 on the cylindrical ejector had little effect on ejector thrust ratio. The divergent-ejector geometry approaches that of the cylindrical with the increased L/D_p , and consequently the increase in the thrust ratio of the divergent ejector over that of the cylindrical became less. Since the conical ejector with a larger shroud is more overexpanded than the cylindrical ejectors, the ejector thrust ratio decreased with the increased L/D_p .

At the secondary flows considered herein, the primary stream is such a large percentage of the total ejector flow that the trends in performance

2912

at zero secondary flow would be expected to be reflected in the thrust performance with secondary flow; subsequently, at a corrected weight-flow ratio of 0.03 and an L/D_p of 0.9, the cylindrical and divergent ejectors generally have a higher ejector thrust ratio than the conical ejector (fig. 10(b)). At P_p/p_0 above 8, the cylindrical ejector, having slightly better secondary-air handling capacity (greater range of P_p/p_0 at a given corrected weight-flow ratio) than the divergent ejector, also has a slightly higher ejector thrust ratio. Increasing the corrected weight-flow ratio to 0.07 resulted in a greater increase in ejector thrust ratio for the cylindrical ejector than for the divergent at P_p/p_0 above about 5 (fig. 10(c)). Increasing L/D_p from 0.9 to 1.6, which also increased the difference in geometry between the cylindrical and conical ejectors, resulted in a larger difference in ejector thrust ratio between these two ejectors (figs. 10(c) and (f)). The geometry of the cylindrical and divergent ejectors became relatively closer together with the increased L/D_p , and consequently the higher secondary-air handling capacity of the cylindrical ejector resulted in the ejector thrust ratio being higher over a wider range of P_p/p_0 than that obtained with the shorter ejectors.

In general, the divergent ejector had a higher ejector thrust ratio at zero secondary flow, but the thrust advantage of the divergent ejector was small at the longer L/D_p . With corrected weight-flow ratios of 0.03 and 0.07, the divergent ejector had the highest ejector thrust ratio at low P_p/p_0 , while the cylindrical ejector was highest at high P_p/p_0 . The thrust advantage of the divergent ejector became smaller with increased secondary flow at low P_p/p_0 , while that of the cylindrical became larger at high P_p/p_0 . The cylindrical ejector became advantageous in ejector thrust ratio over a wider range of P_p/p_0 with both increased secondary flow and increased L/D_p . The conical ejector had the lowest thrust at all conditions.

Effect of wall pressure on ejector thrust ratio. - The influence of wall pressure distribution on the ejector thrust ratio may be seen by consideration of a thrust equation based on the conservation of momentum between the primary-nozzle exit and the shroud exit. Since gross thrust is the difference between the total momentum of a stream and the force exerted on the stream by ambient pressure, an equation for ejector thrust ratio, with frictionless one-dimensional flow assumed, may be written as

$$\frac{F_{ej}}{F_j} = \frac{F_j + F_s - \int_{A_e}^{A_s} (p_w - p_0) dA}{F_j} \quad (1)$$

where the gross thrust of the primary F_j and secondary streams F_s may be evaluated at the primary-nozzle exit with a knowledge of the pumping

characteristics and the ejector geometry. The term $\int_{A_e}^{A_s} (p_w - p_0) dA$

represents the wall pressure force, and, as previously mentioned a rational derivation of this term is not presently available. The ejector thrust ratio, calculated from equation (1) by using the measured wall pressure distribution along the length of shrouds, is presented in figure 11 as a function of P_p/p_0 for conical, cylindrical, and divergent ejectors at a secondary flow of zero and at constant secondary pressure ratios of 1.0 and 3.0 for ejectors having an exit-diameter ratio of 1.2 and a spacing ratio of 1.6. The ejector thrust ratio, which was also calculated from equation (1) by neglecting the wall pressure term, is shown on figure 11 as a dashed curve. Also shown are experimentally obtained values of thrust. A comparison of the dashed lines with the solid lines illustrates the effect of wall pressure on ejector thrust ratio. As expected, the effect of neglecting the wall pressure term was negligible for the cylindrical ejector, had only a slight effect on the divergent, but had an appreciably greater effect on the conical ejector, which had a relatively large change in area from shroud inlet to exit. The good agreement between measured thrust and that calculated from equation (1) by using the wall pressure force term indicates that the frictional forces were low and illustrates the possibility of obtaining ejector thrust performance by using a measurement of wall pressure distribution. Also indicated is the possibility of predicting the thrust by a simple one-dimensional equation if a rational or empirical procedure for predicting the wall pressure force term is available.

CONCLUDING REMARKS

An investigation was made of the performance of four divergent-ejector configurations having exit-diameter ratios of 1.2 and 1.3, with minimum-shroud diameter ratios of 1.1 and 1.2, respectively. For both exit-diameter ratios, spacing ratios of 0.87 and 1.6 were investigated.

A comparison of the performance of conical, cylindrical, and divergent ejectors showed that on the basis of similar design variables (exit-diameter ratio and spacing ratio) each configuration had merit. In general, the divergent ejector had the highest ejector thrust ratio at zero secondary flow, but the thrust advantage of the divergent ejector

was small at the longer spacing ratio. With corrected weight-flow ratios of 0.03 and 0.07, the divergent ejector had the highest ejector thrust ratio at low primary pressure ratios, while the cylindrical ejector was highest at high primary pressure ratios. The thrust advantage of the divergent ejector became smaller with increased secondary flow at low primary pressure ratios, while that of the cylindrical ejector became larger at high primary pressure ratios. The cylindrical ejector became advantageous in ejector thrust ratio over a wider range of primary pressure ratio with both increased secondary flow and increased spacing ratio. The conical ejector, however, can pump a given corrected weight flow over a wider range of primary pressure ratio at the expense of a relatively low ejector thrust. The divergent ejector had the smallest range of primary pressure ratio for a given corrected weight-flow ratio.

The possibility of obtaining ejector thrust performance from a simple one-dimensional equation and from a measurement of wall pressure distribution was illustrated by the good agreement between measured and calculated thrust.

Lewis Flight Propulsion Laboratory
National Advisory Committee for Aeronautics
Cleveland, Ohio, October 19, 1953

REFERENCES

1. Samuels, John C., and Yanowitz, Herbert: Analysis of Several Methods of Pumping Cooling Air for Turbojet-Engine Afterburners. NACA RM E52K26, 1953.
2. Huddleston, S. C., Wilsted, H. D., and Ellis, C. W.: Performance of Several Air Ejectors with Conical Mixing Sections and Small Secondary Flow Rates. NACA RM E8D23, 1948.
3. Ellis, C. W., Hollister, D. P., and Sargent, A. F., Jr.: Preliminary Investigation of Cooling-Air Ejector Performance at Pressure Ratios from 1 to 10. NACA RM E51H21, 1951.
4. Greathouse, W. K., and Hollister, D. P.: Preliminary Air-Flow and Thrust Calibrations of Several Conical Cooling-Air Ejectors with a Primary to Secondary Temperature Ratio of 1.0. I - Diameter Ratios of 1.21 and 1.10. NACA RM E52E21, 1952.
5. Greathouse, W. K., and Hollister, D. P.: Preliminary Air-Flow and Thrust Calibrations of Several Conical Cooling-Air Ejectors with a Primary to Secondary Temperature Ratio of 1.0. II - Diameter Ratios of 1.06 and 1.40. NACA RM E52F26, 1952.

6. Greathouse, W. K., and Hollister, D. P.: Air-Flow and Thrust Characteristics of Several Cylindrical Cooling-Air Ejectors with a Primary to Secondary Temperature Ratio of 1.0. NACA RM E52L24, 1953.
7. Kochendorfer, Fred D., and Rousso, Morris D.: Performance Characteristics of Aircraft Cooling Ejectors Having Short Cylindrical Shrouds. NACA RM E51E01, 1951.
8. Ellis, C. W., Hollister, D. P., and Wilsted, H. D.: Investigation of Performance of Several Double-Shroud Ejectors and Effect of Variable-Area Exhaust Nozzle on Single Ejector Performance. NACA RM E52D25, 1952.
9. Hollister, Donald P., and Greathouse, William K.: Performance of Double-Shroud Ejector Configurations with Primary Pressure Ratios from 1.0 to 10. NACA RM E52K17, 1953.

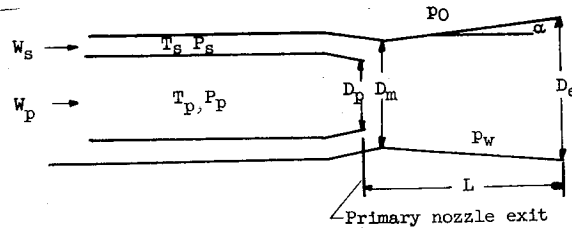

A	area, sq ft
A_e	shroud-exit area, sq ft
A_s	shroud-inlet area, sq ft
C_D	primary-nozzle discharge coefficient, ratio of measured mass flow to ideal mass flow
C_F	primary-nozzle thrust coefficient, ratio of measured thrust to ideal thrust of convergent nozzle, $\frac{F_{\text{measured}}}{[mV + A(p - P_0)]_{\text{ideal}}}$
D_e	exit diameter of secondary shroud, ft
D_e/D_p	exit-diameter ratio
D_m	minimum diameter of secondary shroud, ft
D_m/D_p	minimum-diameter ratio
D_p	exit diameter of primary nozzle, ft
F_{ej}	ejector gross thrust, lb
F_{ej}/F_j	ejector thrust ratio
F_j	gross thrust of primary nozzle without secondary shroud, lb
F_s	gross thrust of secondary stream at primary-nozzle exit, lb
L	spacing distance from primary exit to shroud exit, ft
L/D_p	spacing ratio
m	mass flow, slugs/sec
P_p	primary total pressure, lb/sq ft
P_p/P_0	primary pressure ratio
P_s	secondary total pressure, lb/sq ft
P_s/P_0	secondary pressure ratio
p	static pressure, lb/sq ft
P_0	exhaust ambient pressure, lb/sq ft
P_w	wall pressure, lb/sq ft
T_p	primary total temperature, °R
T_s	secondary total temperature, °R
v	velocity, ft/sec
W_p	primary weight flow, lb/sec
W_s	secondary weight flow, lb/sec
$\frac{W_s \sqrt{T_s}}{W_p \sqrt{T_p}}$	corrected weight-flow ratio
α	divergence angle, deg

Figure 1. - Nomenclature for ejector investigation.

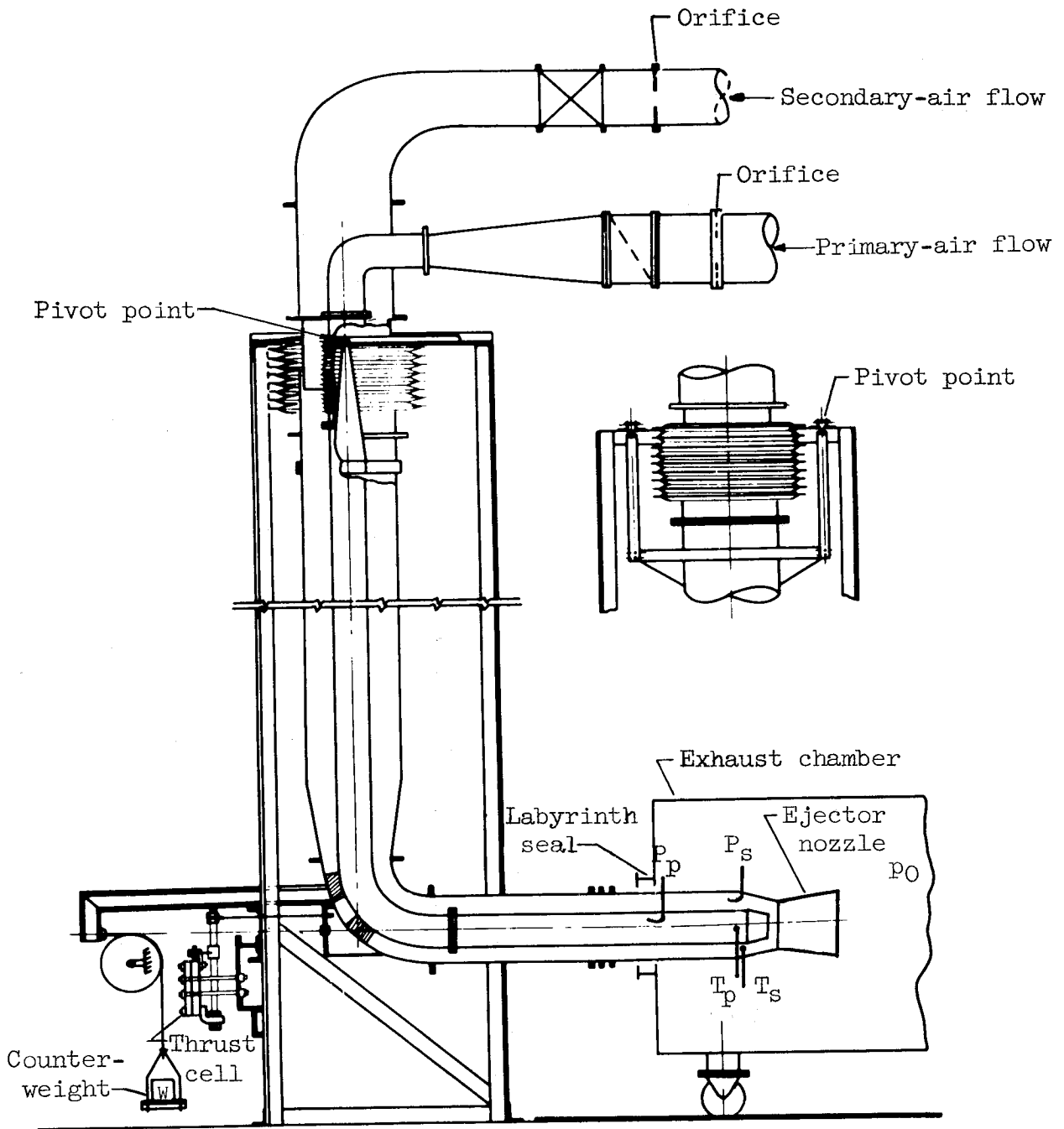

Figure 2. - Schematic diagram of model setup for ejector investigation.

2912

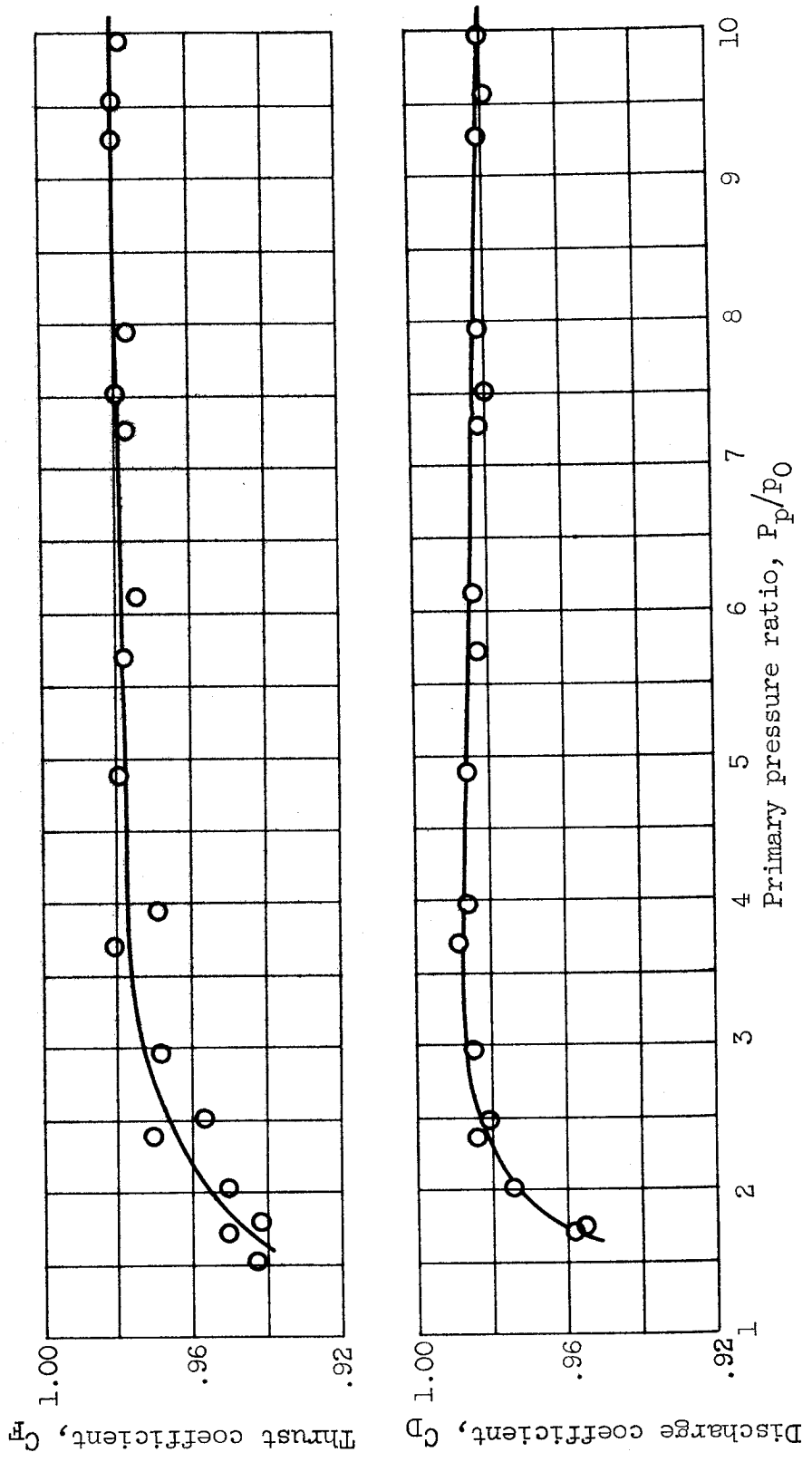
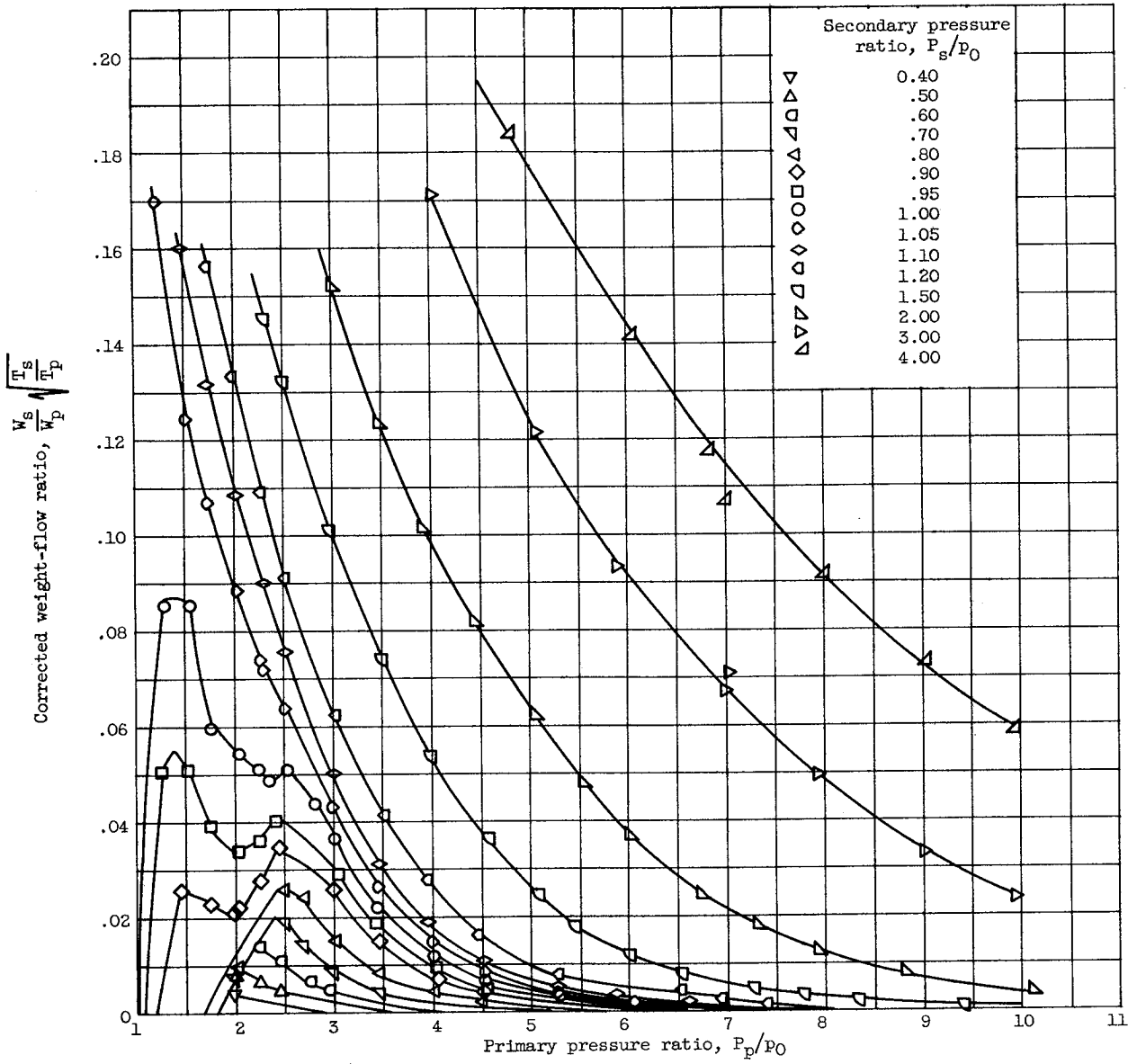

Figure 3. - Primary-nozzle coefficients.



(a) Minimum-diameter ratio, 1.11; exit-diameter ratio, 1.21; spacing ratio, 0.867.

Figure 4. - Pumping characteristics of divergent ejectors.

2912

2912
CI-3

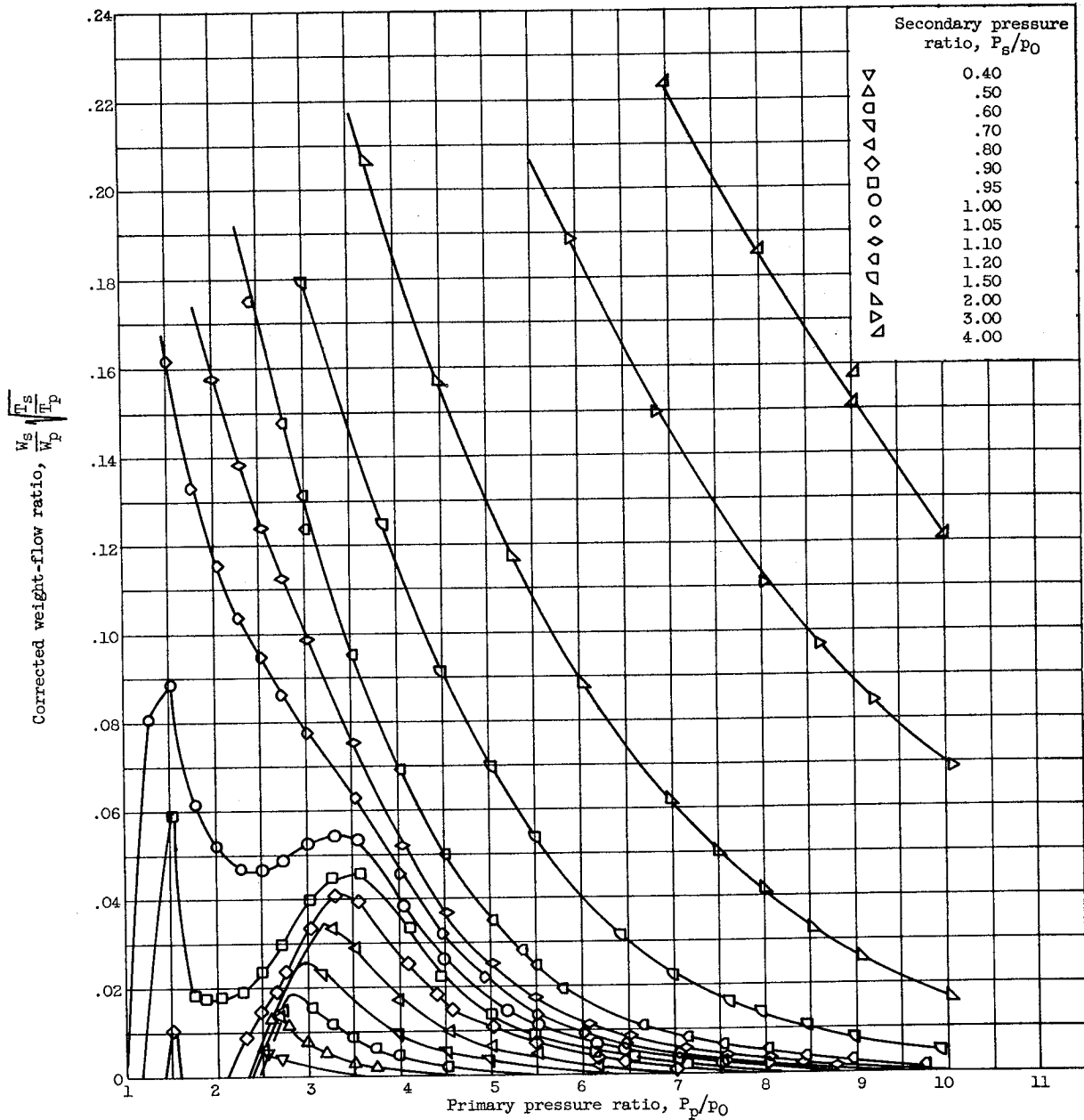

(c) Minimum-diameter ratio, 1.21; exit-diameter ratio, 1.31; spacing ratio, 0.874.

Figure 4. - Continued. Pumping characteristics of divergent ejectors.

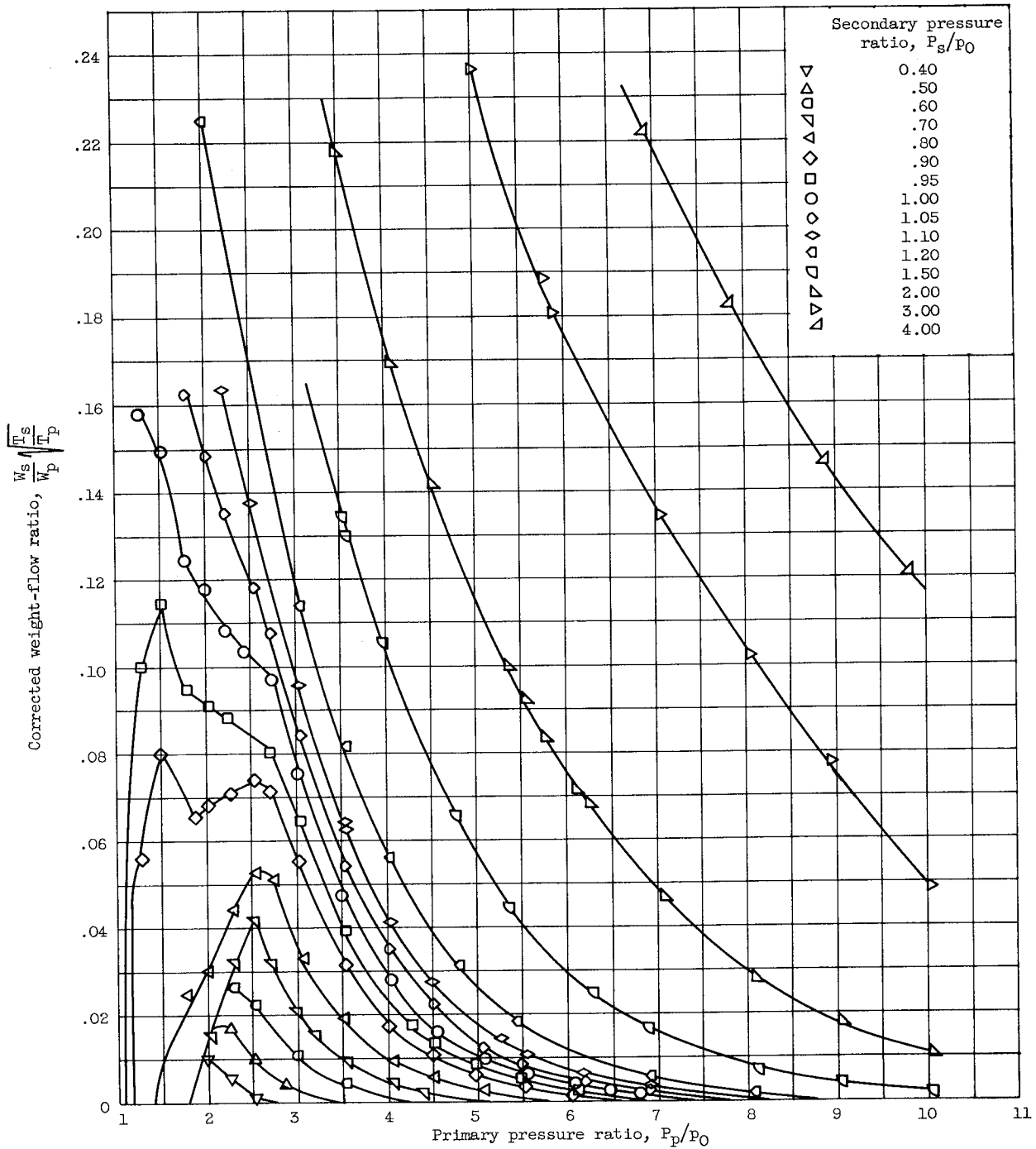

(d) Minimum-diameter ratio, 1.20; exit-diameter ratio, 1.31; spacing ratio, 1.63.

Figure 4. - Concluded. Pumping characteristics of divergent ejectors.

2912
CI-3 back

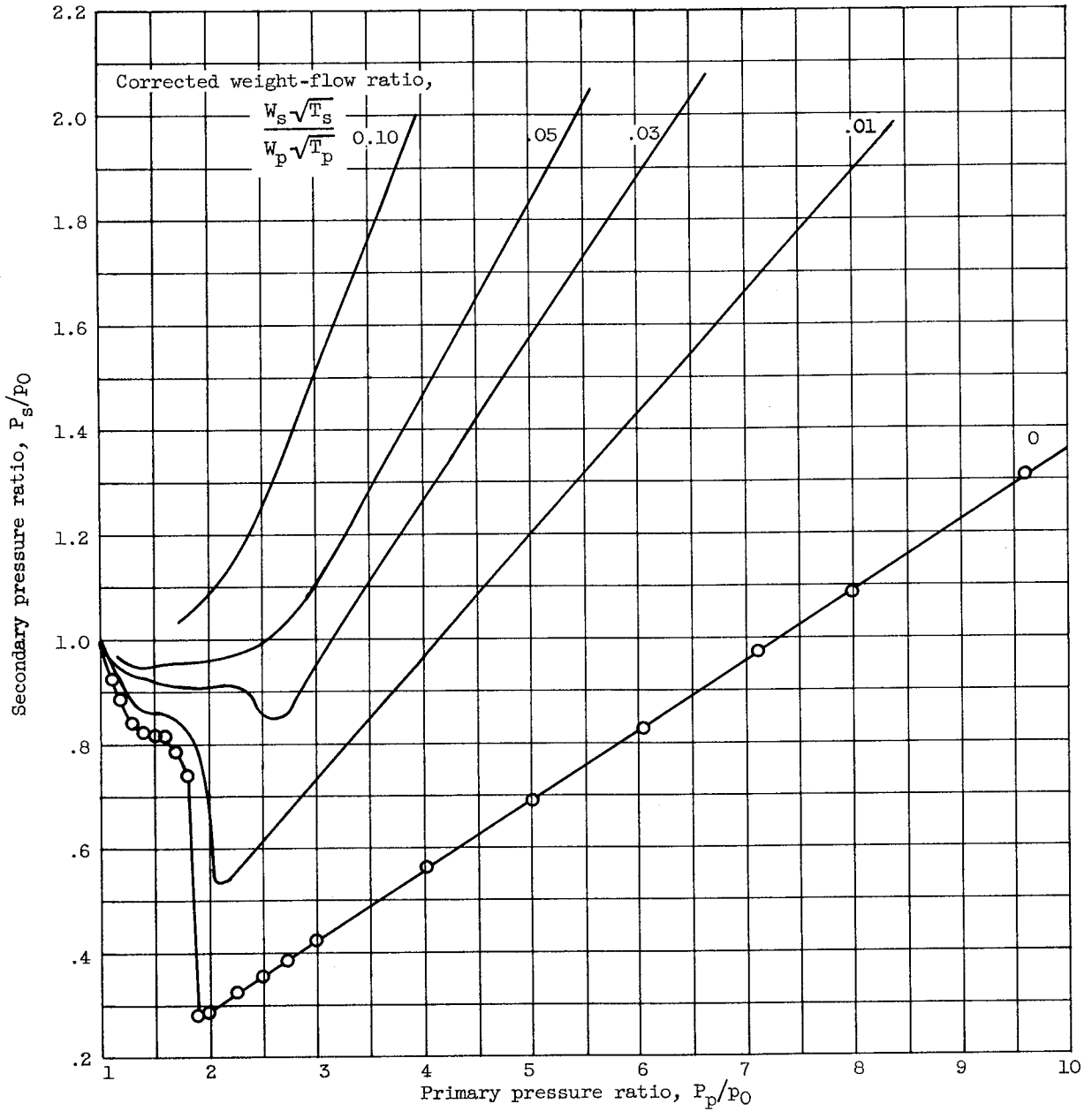

(a) Minimum-diameter ratio, 1.11; exit-diameter ratio, 1.21; spacing ratio, 0.867.

Figure 5. - Cross plot of pumping characteristics of figure 4.

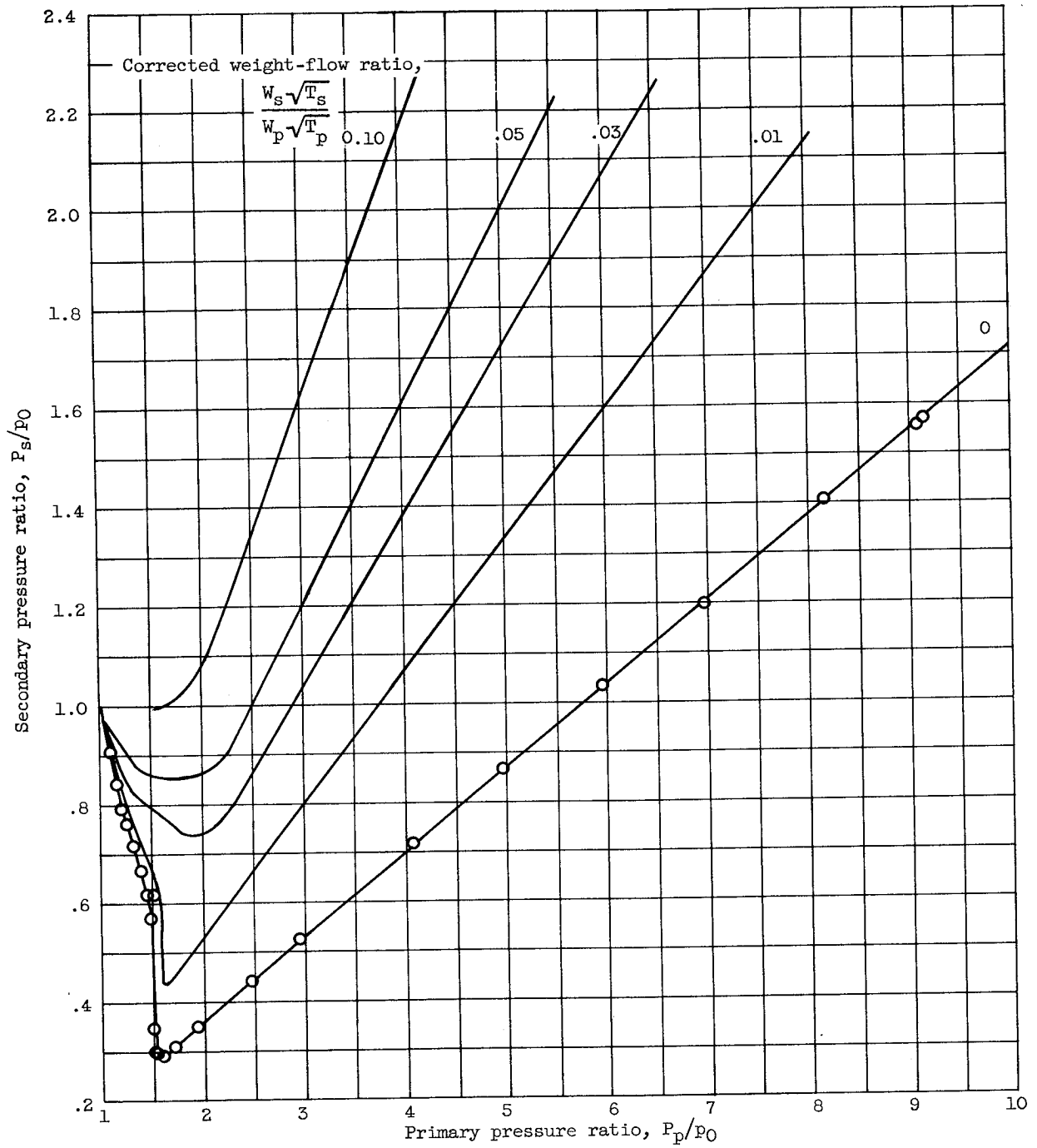

(b) Minimum-diameter ratio, 1.11; exit-diameter ratio, 1.20; spacing ratio, 1.63.

Figure 5. - Continued. Cross plot of pumping characteristics of figure 4.

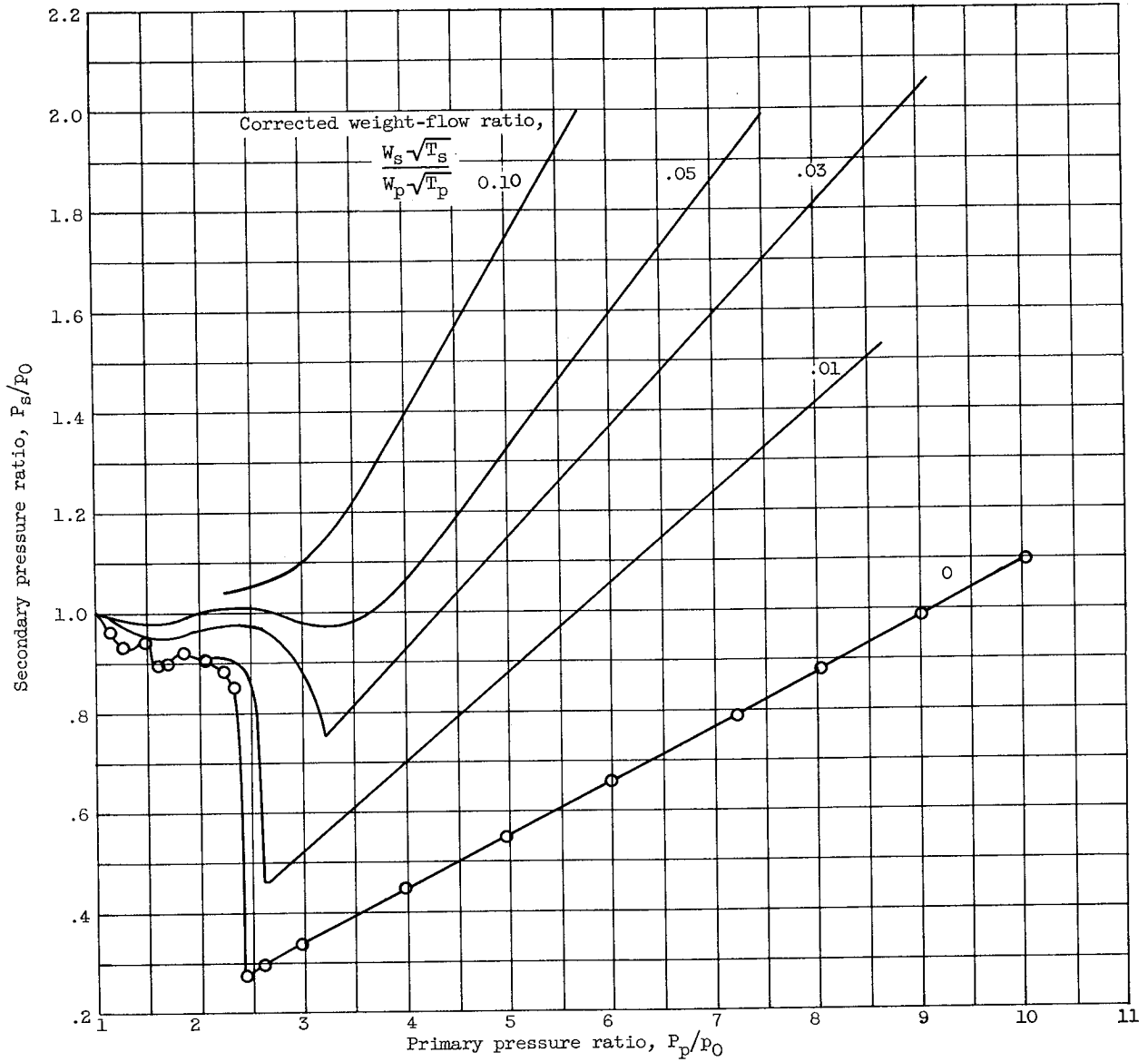

(c) Minimum-diameter ratio, 1.21; exit-diameter ratio, 1.31; spacing ratio, 0.874.

Figure 5. - Continued. Cross plot of pumping characteristics of figure 4.

2912

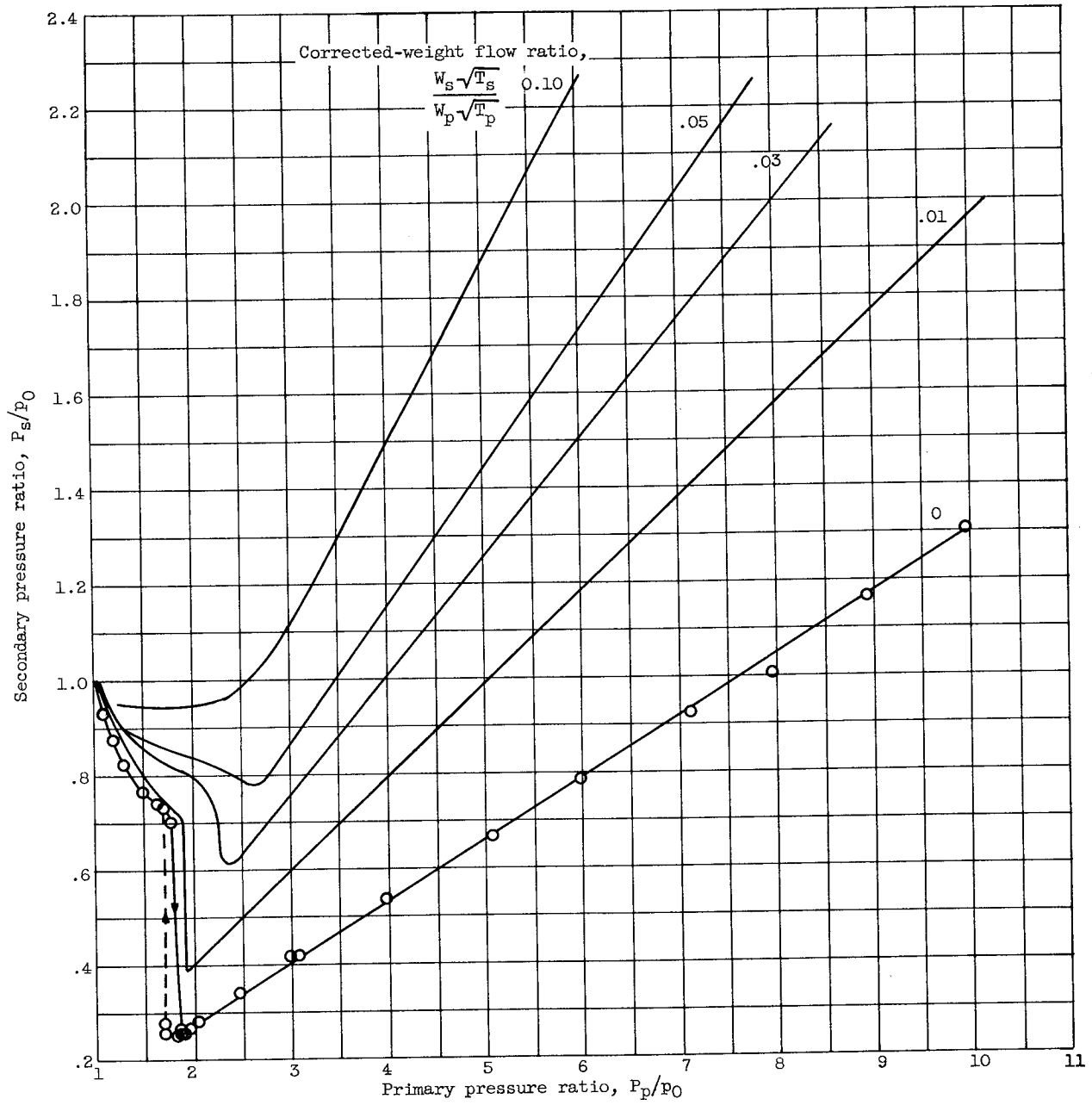

(d) Minimum-diameter ratio, 1.20; exit-diameter ratio, 1.31; spacing ratio, 1.63.

Figure 5. - Concluded. Cross plot of pumping characteristics of figure 4.

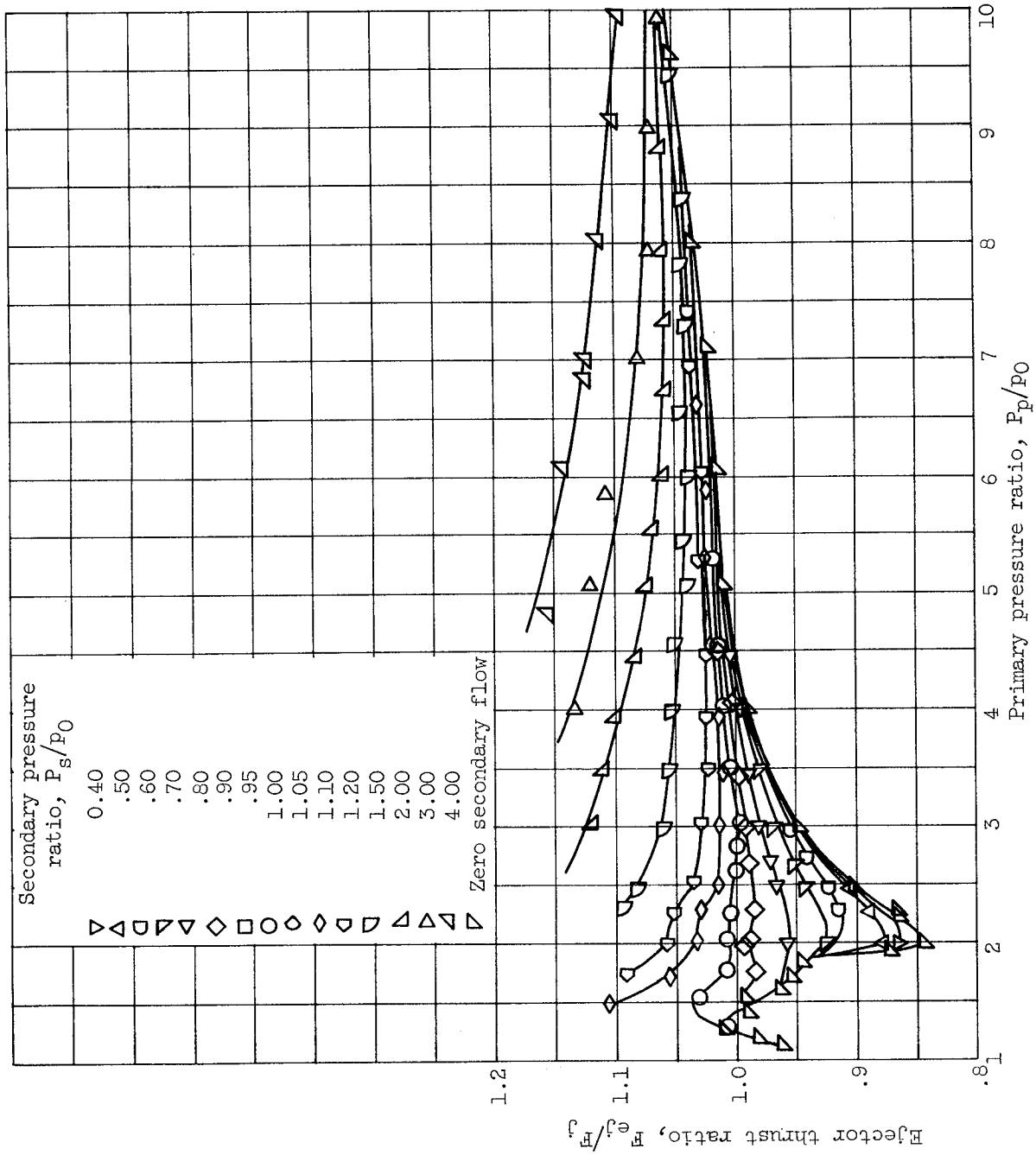

(a) Minimum-diameter ratio, 1.11; exit-diameter ratio, 1.21; spacing ratio, 0.867.

Figure 6. - Thrust characteristics of divergent ejectors.

2912

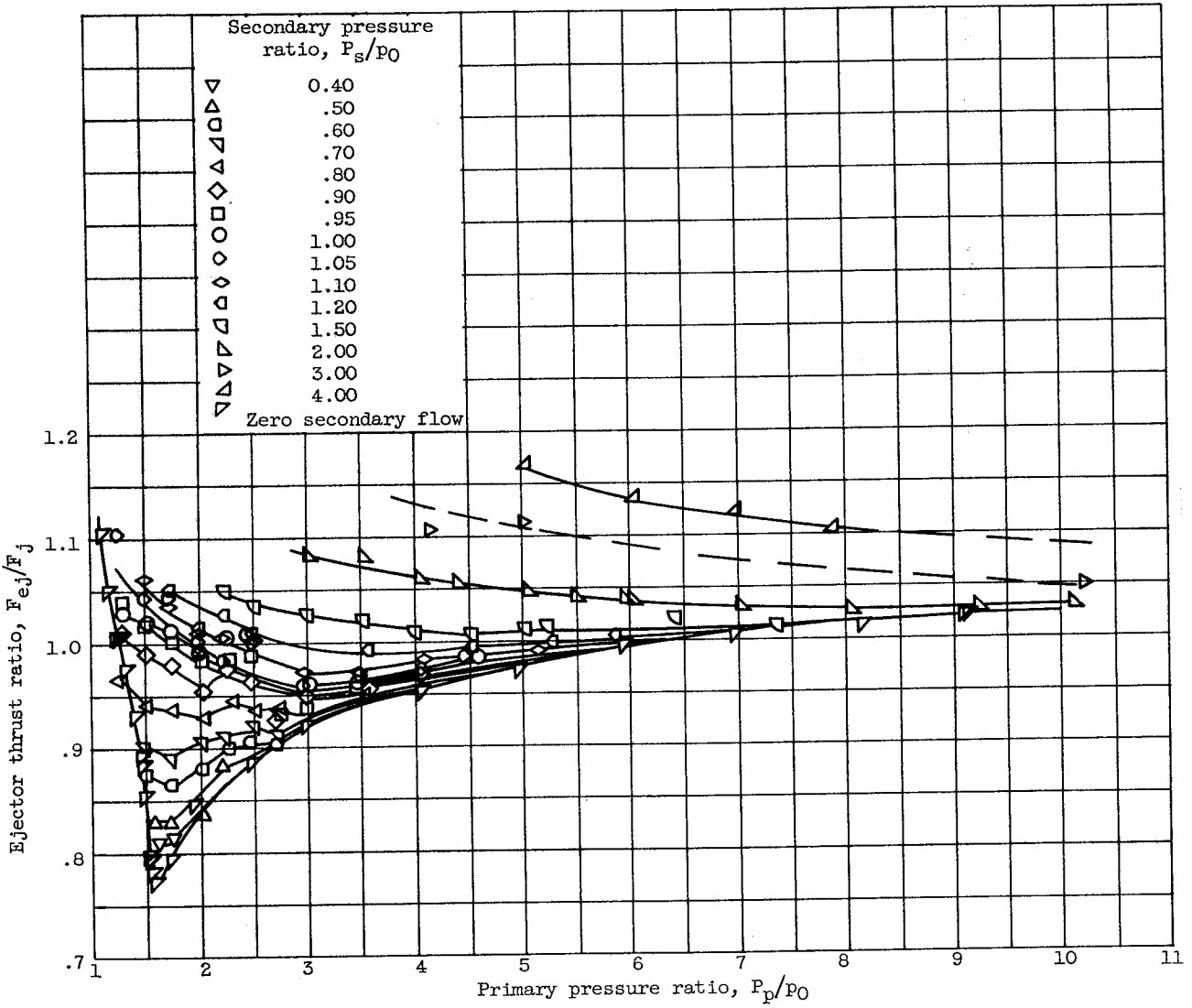
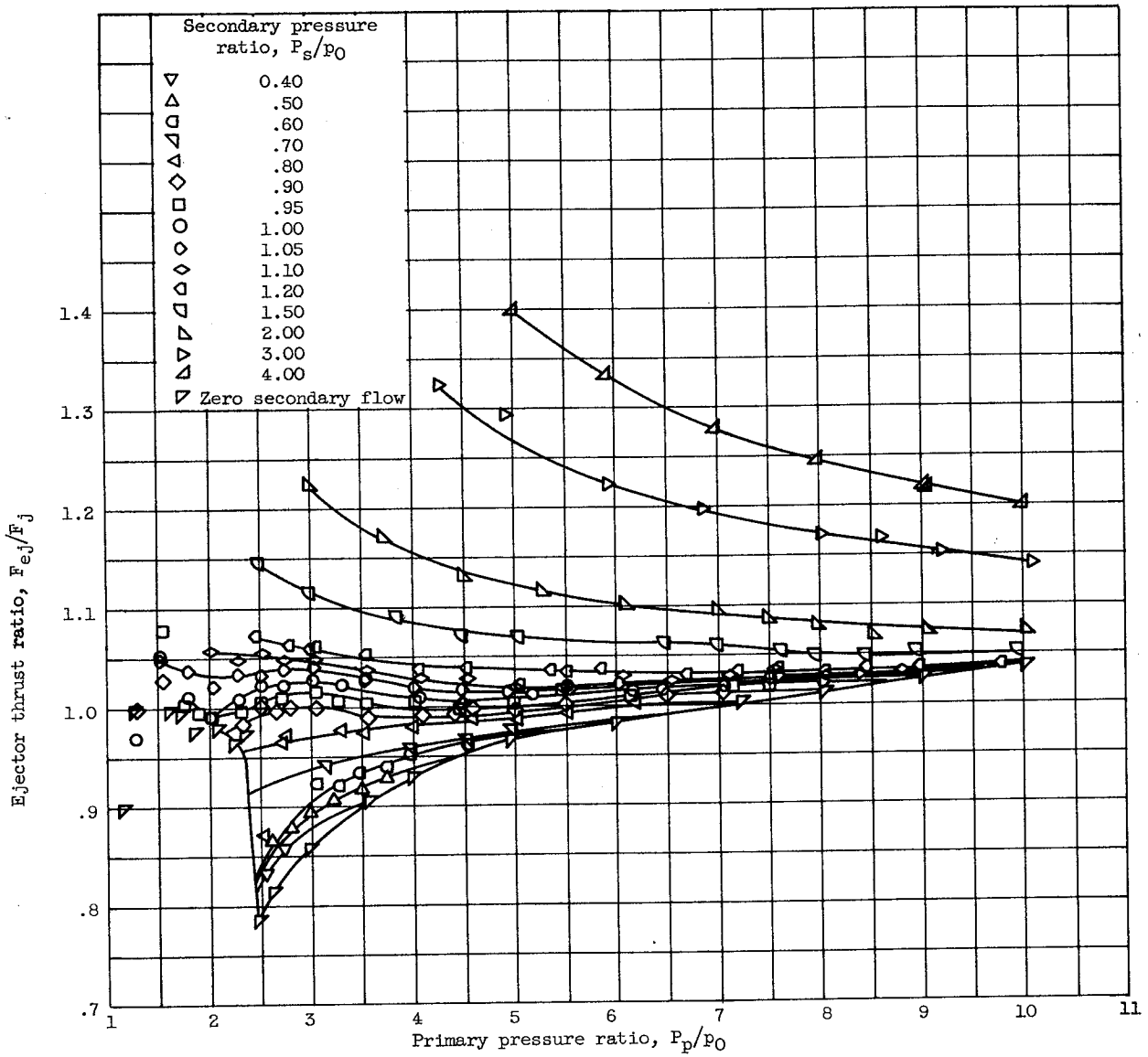

Figure 6. - Continued. Thrust characteristics of divergent ejectors.

2912
CI-4



(c) Minimum-diameter ratio, 1.21; exit-diameter ratio, 1.31; spacing ratio, 0.874.

Figure 6. - Continued. Thrust characteristics of divergent ejectors.

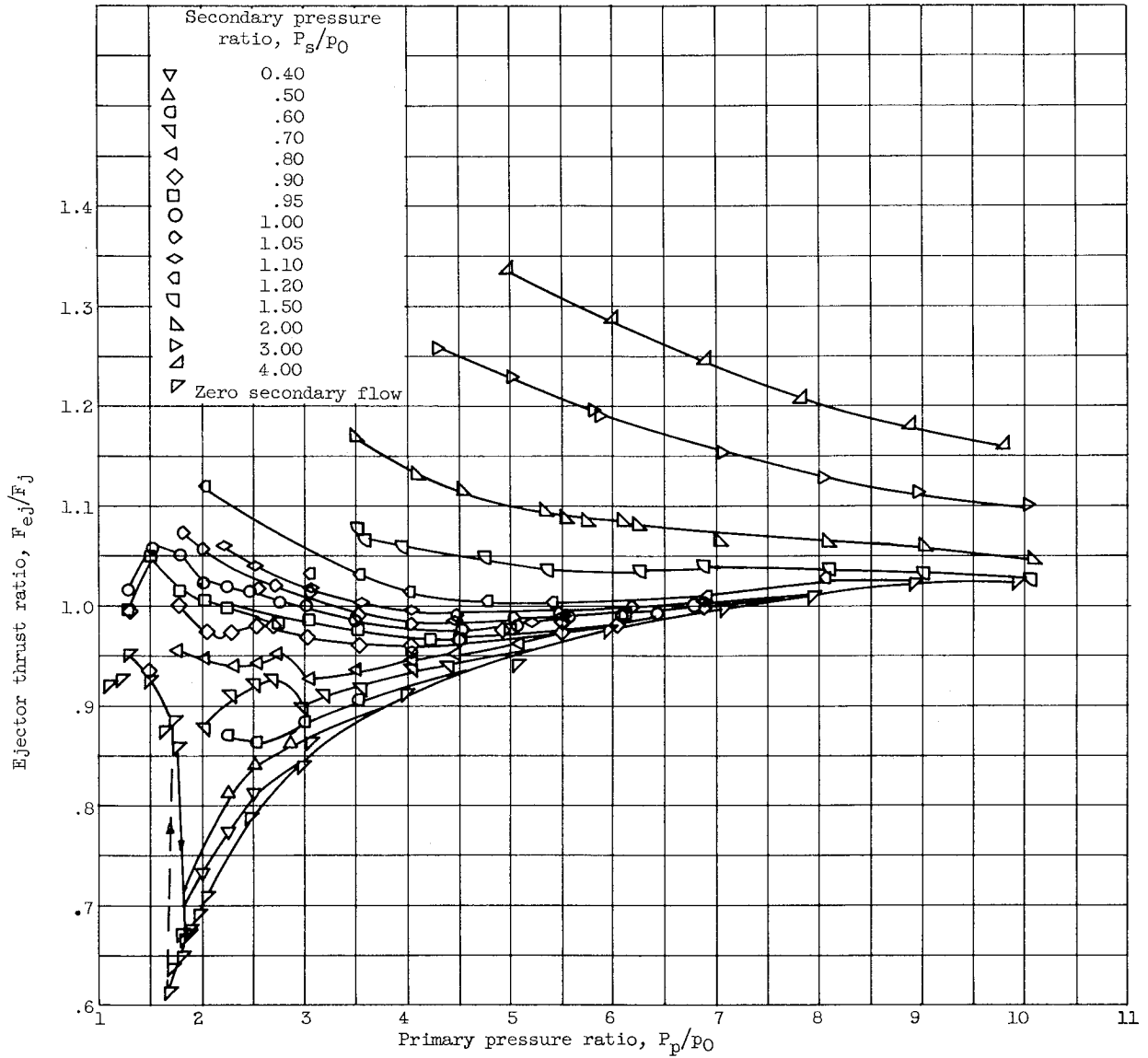

(d) Minimum-diameter ratio, 1.20; exit-diameter ratio, 1.31; spacing ratio, 1.63.

Figure 6. - Concluded. Thrust characteristics of divergent ejectors.

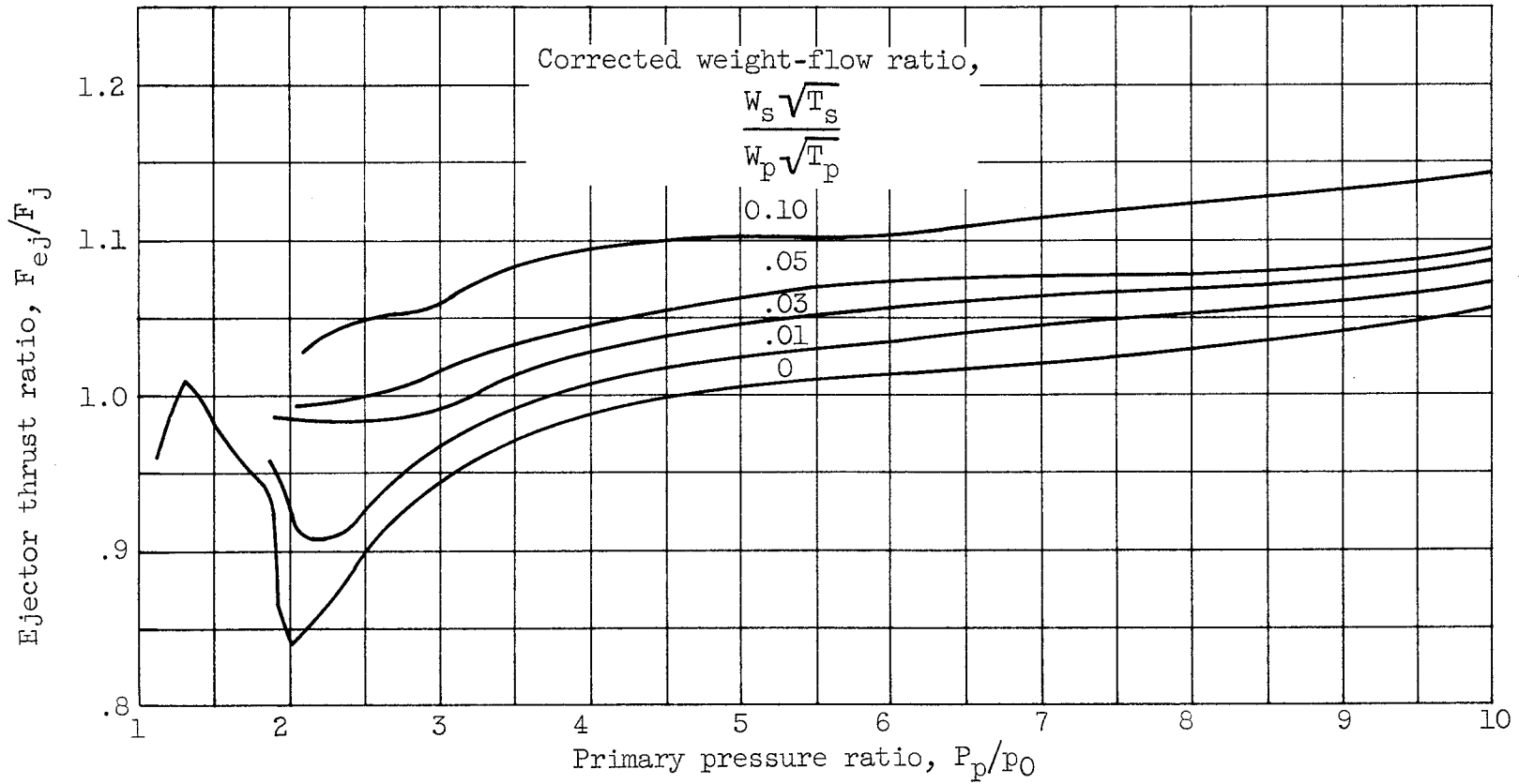

(a) Minimum-diameter ratio, 1.11; exit-diameter ratio, 1.21; spacing ratio, 0.867.

Figure 7. - Cross plots of thrust characteristics of figure 6.

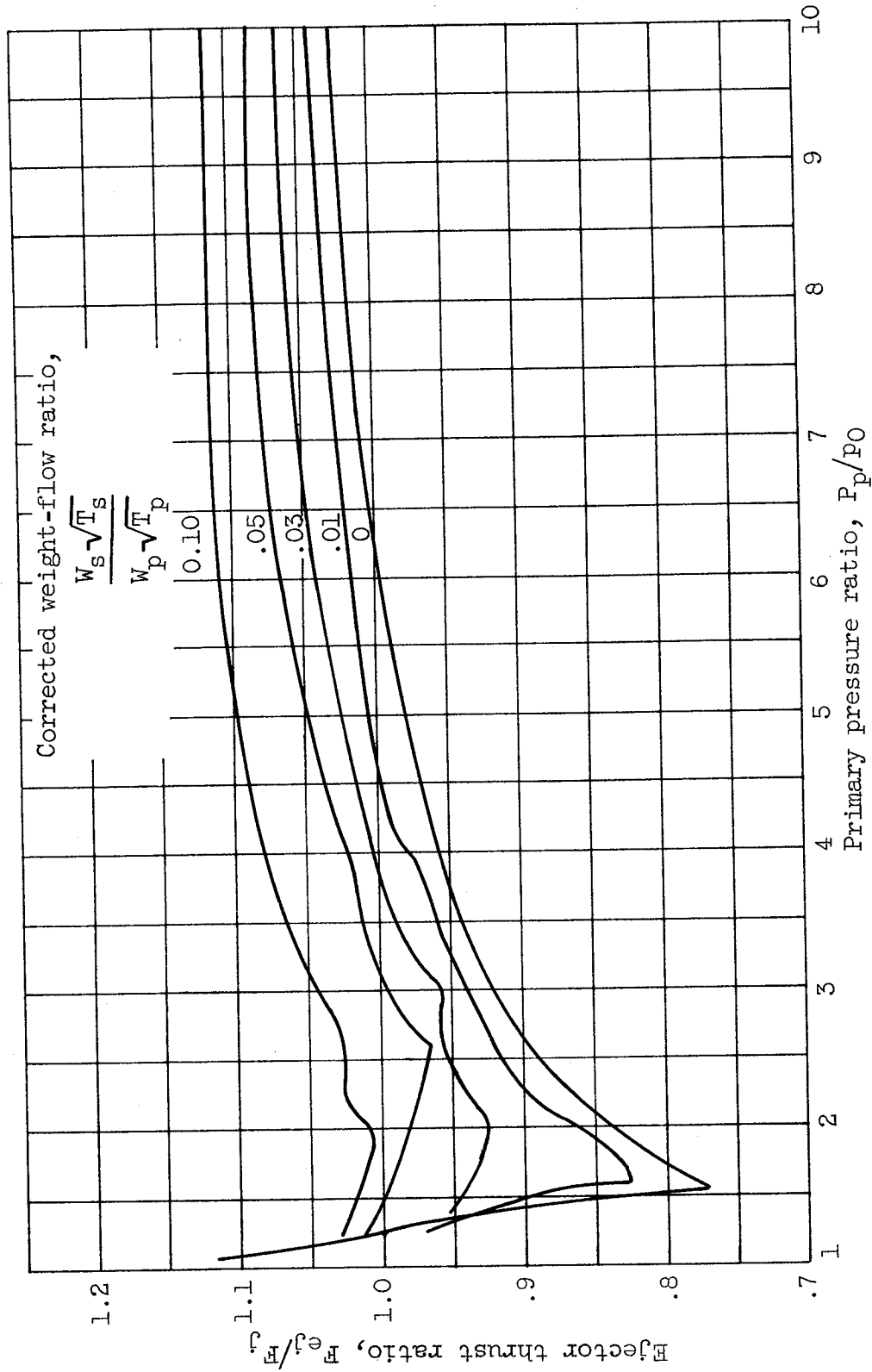

(b) Minimum-diameter ratio, 1.11; exit-diameter ratio, 1.20; spacing ratio, 1.63.

Figure 7. - Continued. Cross plots of thrust characteristics of figure 6.

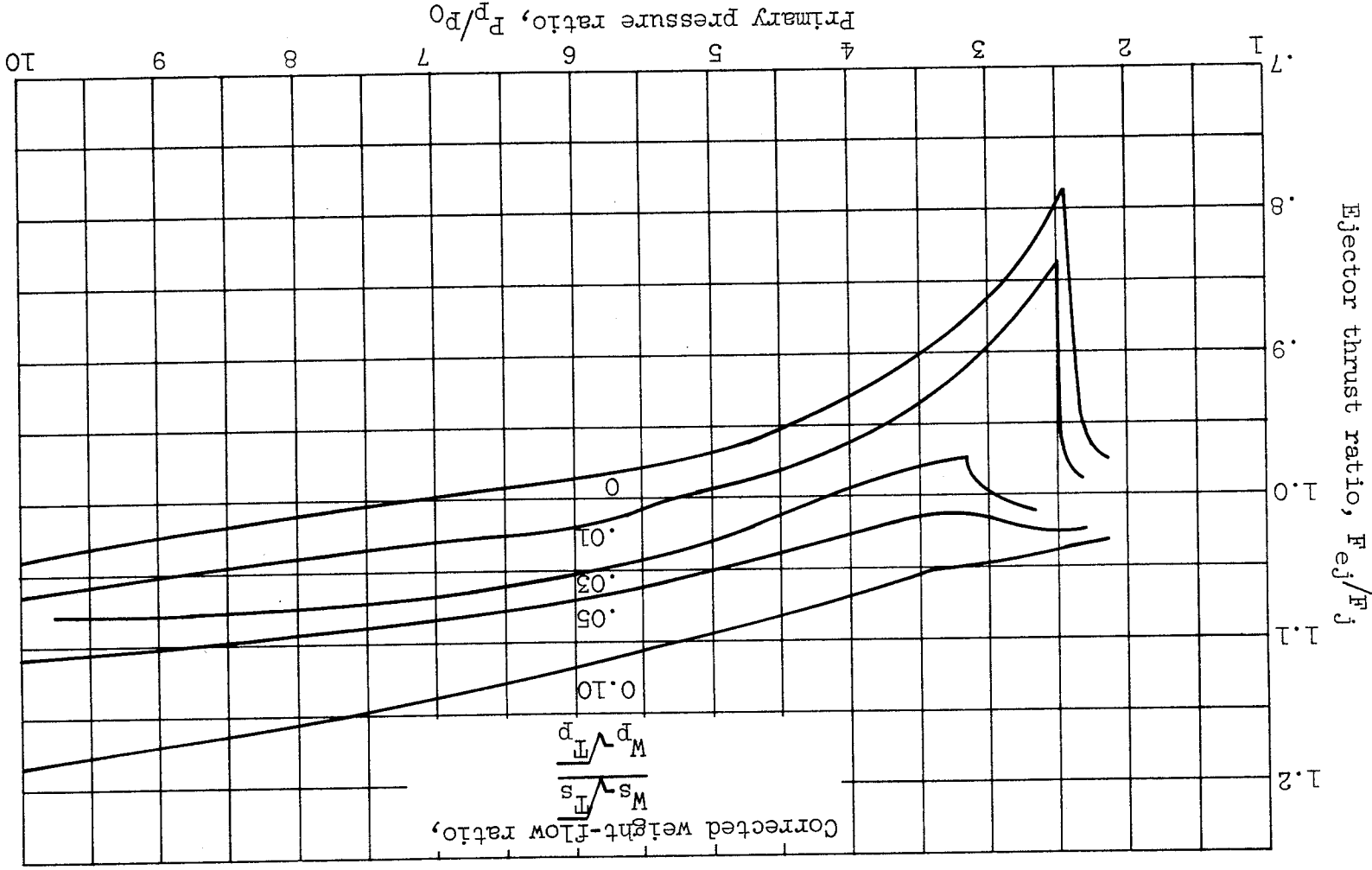

(c) Minimum-diameter ratio, 1.21; exit-diameter ratio, 1.31; spacing ratio, 0.874. Figure 7. - Continued. Cross plots of thrust characteristics of figure 6.

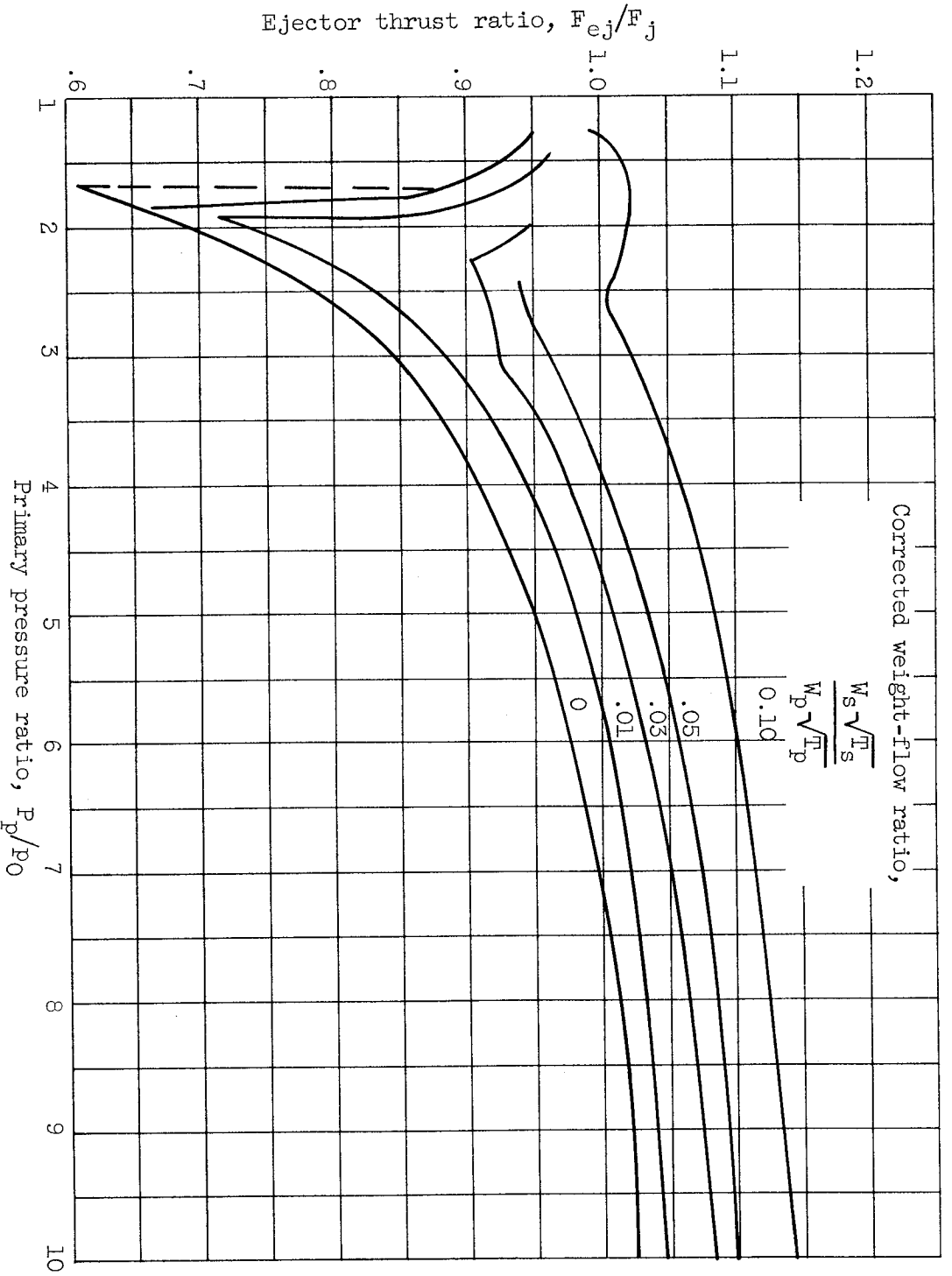

(d) Minimum-diameter ratio, 1.20; exit-diameter ratio, 1.31; spacing ratio, 1.63.
 Figure 7. - Concluded. Cross plots of thrust characteristics of figure 6.

2769

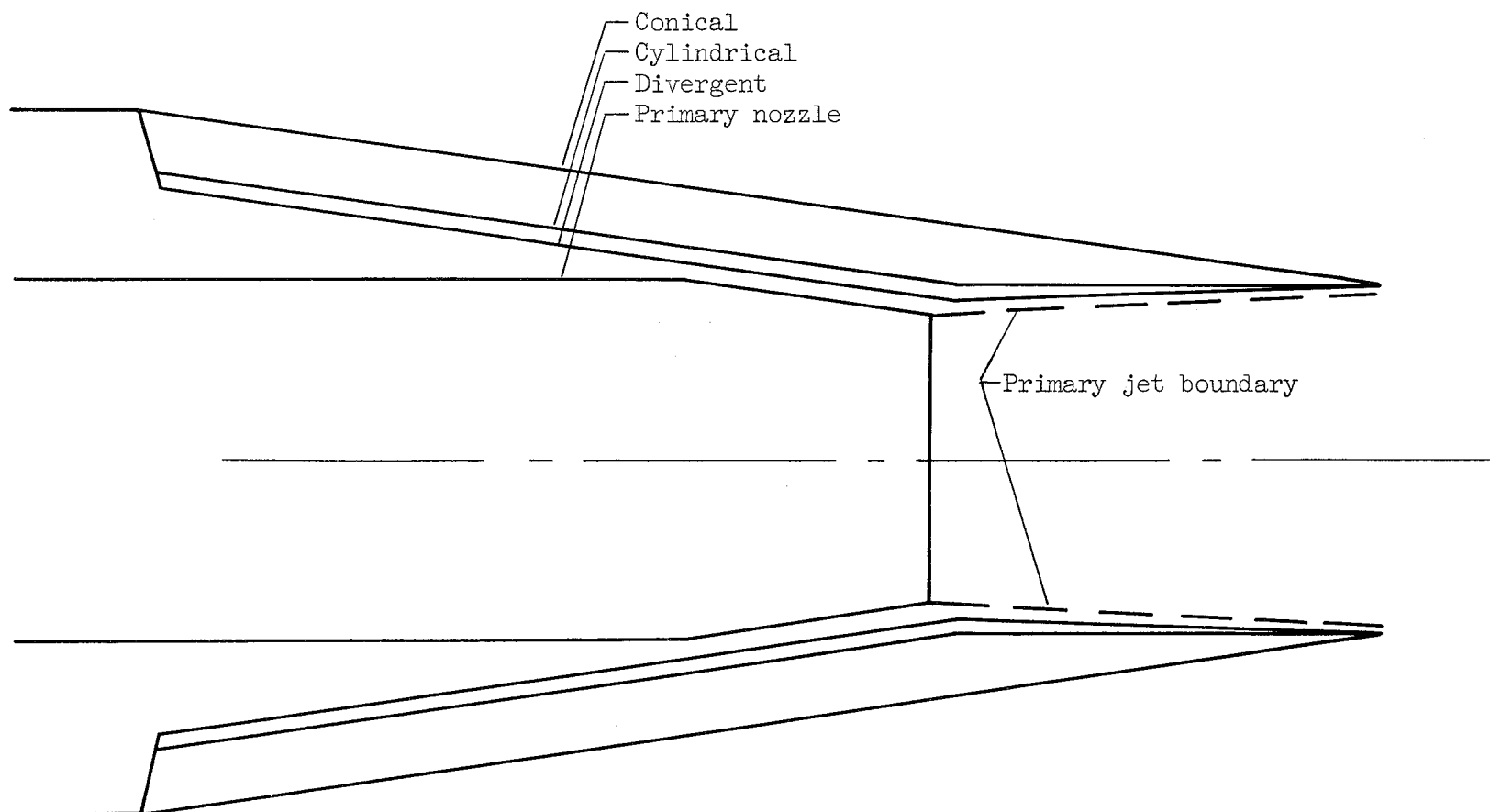
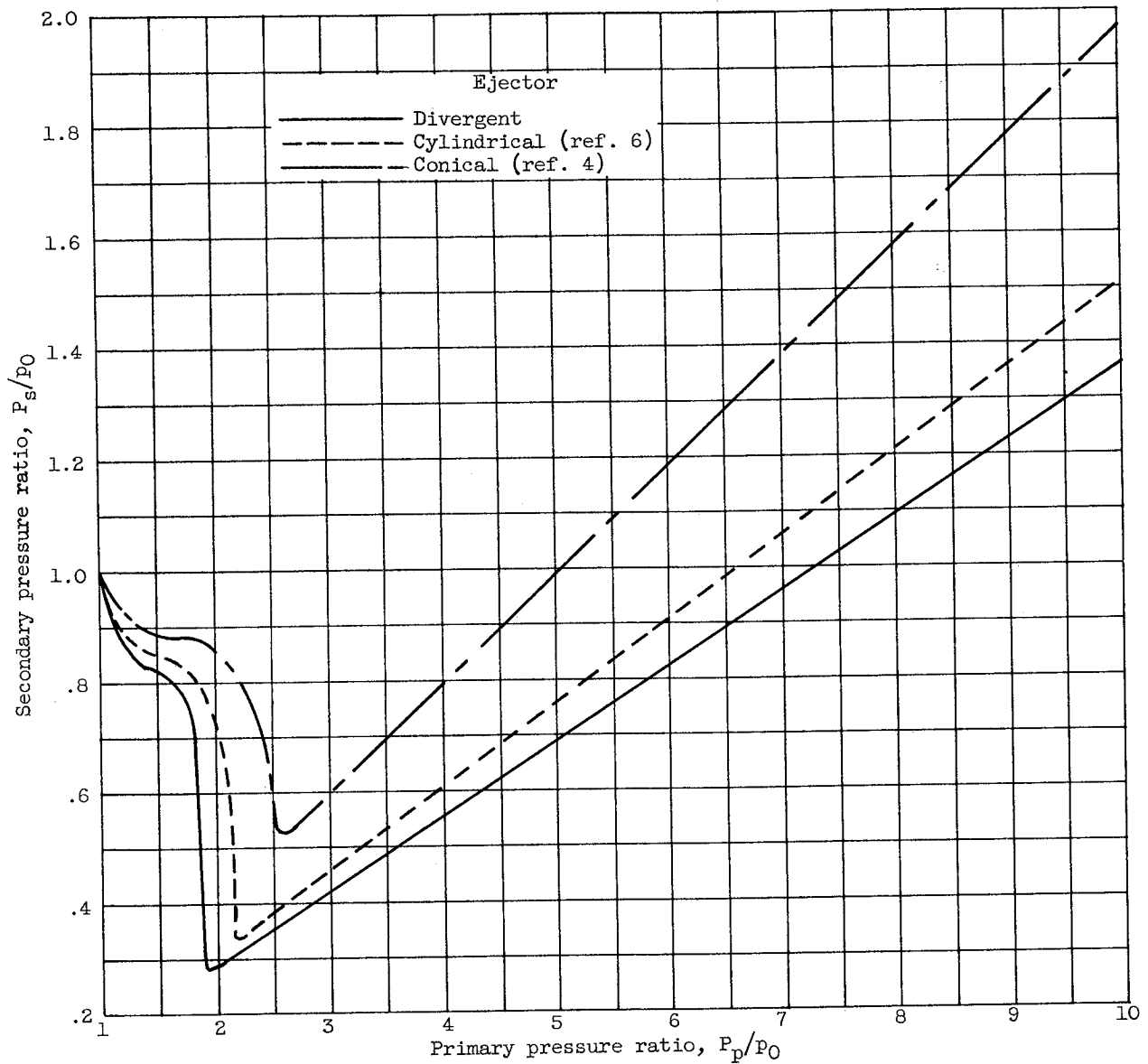

Figure 8. - Comparison of geometries of conical, cylindrical, and divergent ejectors with same exit-diameter ratio and spacing ratio.



(a) Zero secondary flow; spacing ratio, 0.9.

Figure 9. - Comparison of pumping characteristics of several ejectors. Exit-diameter ratio, 1.2.

2912
CI-5

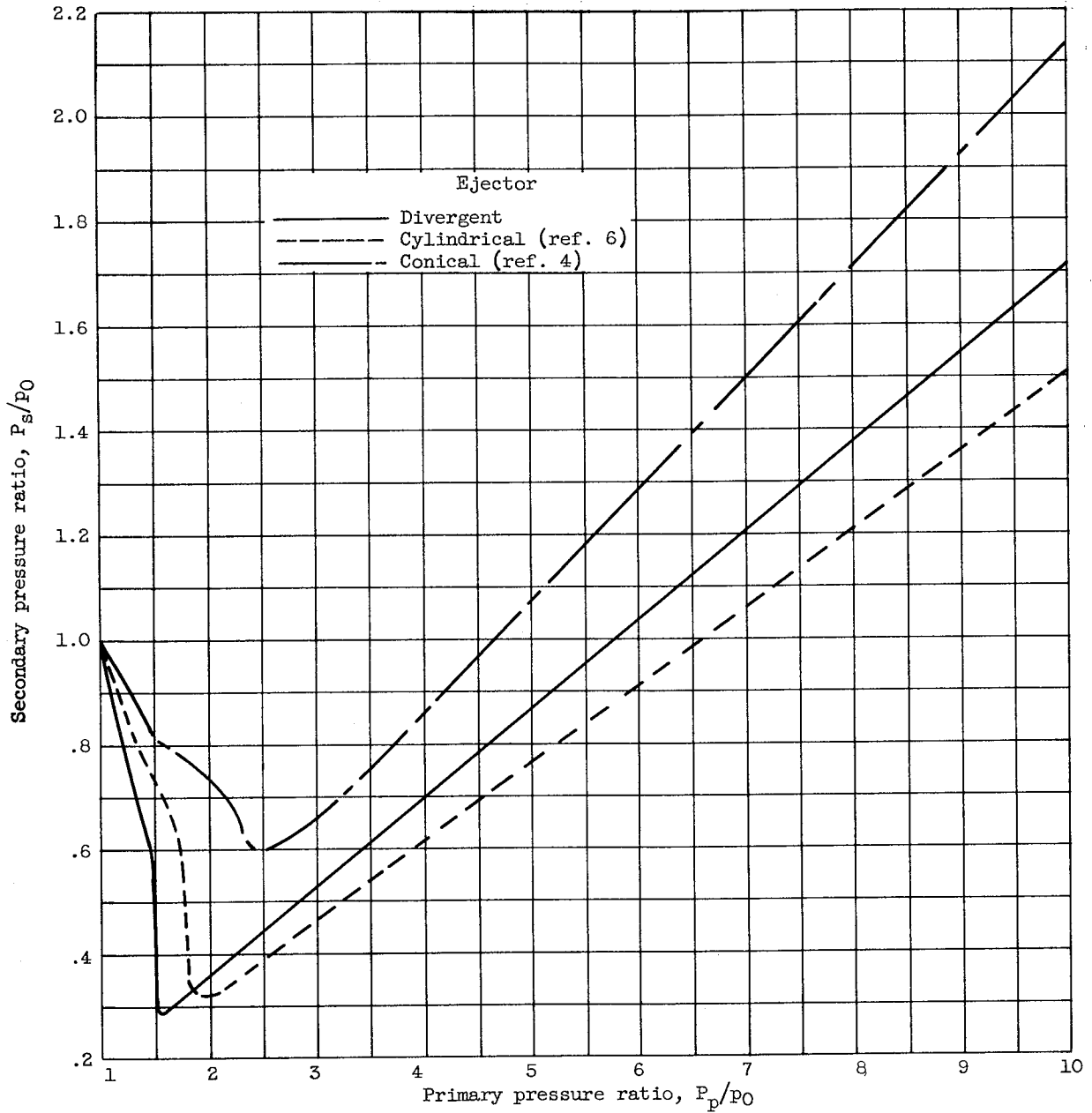

(b) Zero secondary flow; spacing ratio, 1.6.

Figure 9. - Continued. Comparison of pumping characteristics of several ejectors.
Exit-diameter ratio, 1.2.

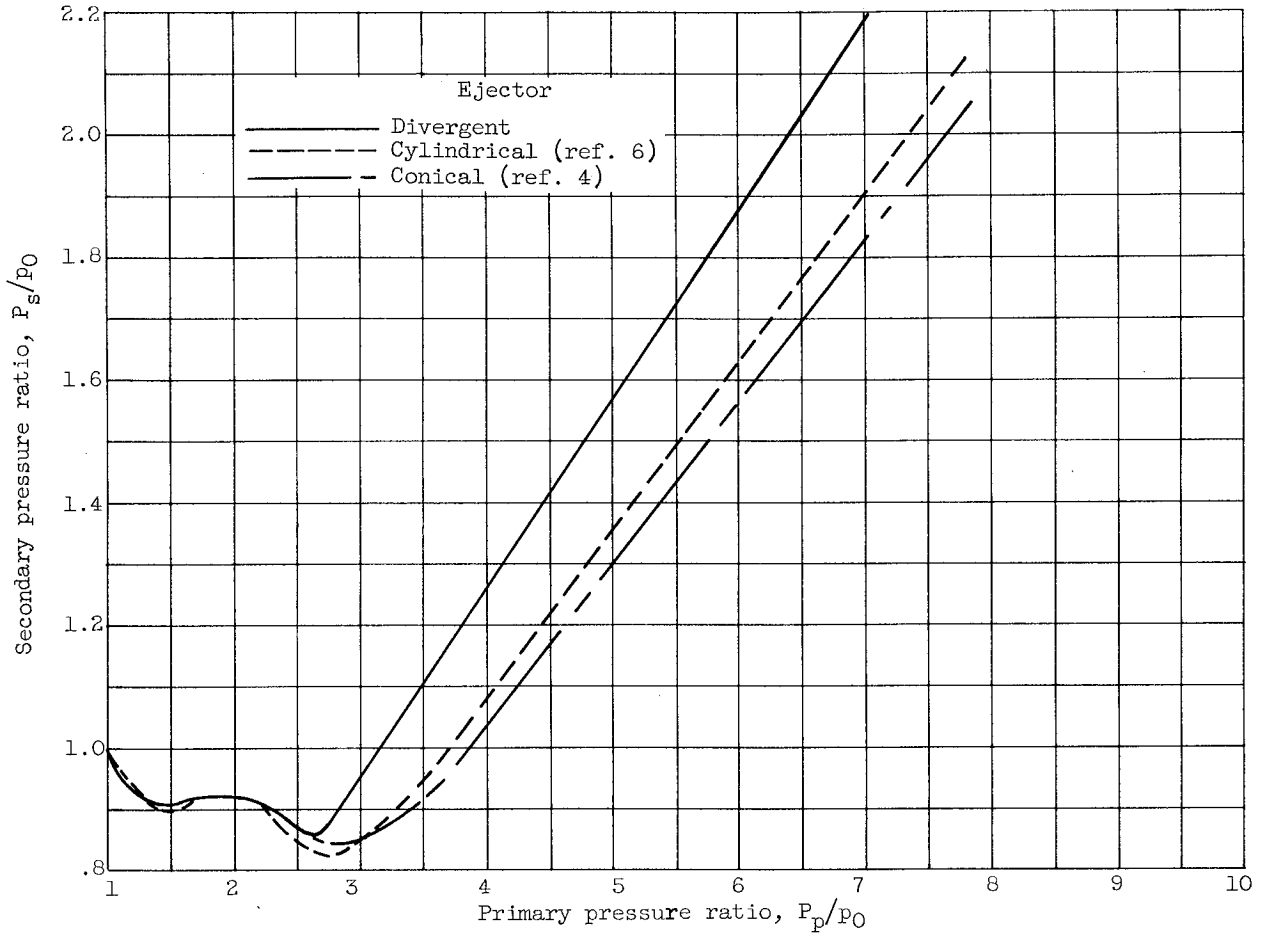

(c) Corrected weight-flow ratio, 0.03; spacing ratio, 0.9.

Figure 9. - Continued. Comparison of pumping characteristics of several ejectors.
Exit-diameter ratio, 1.2.

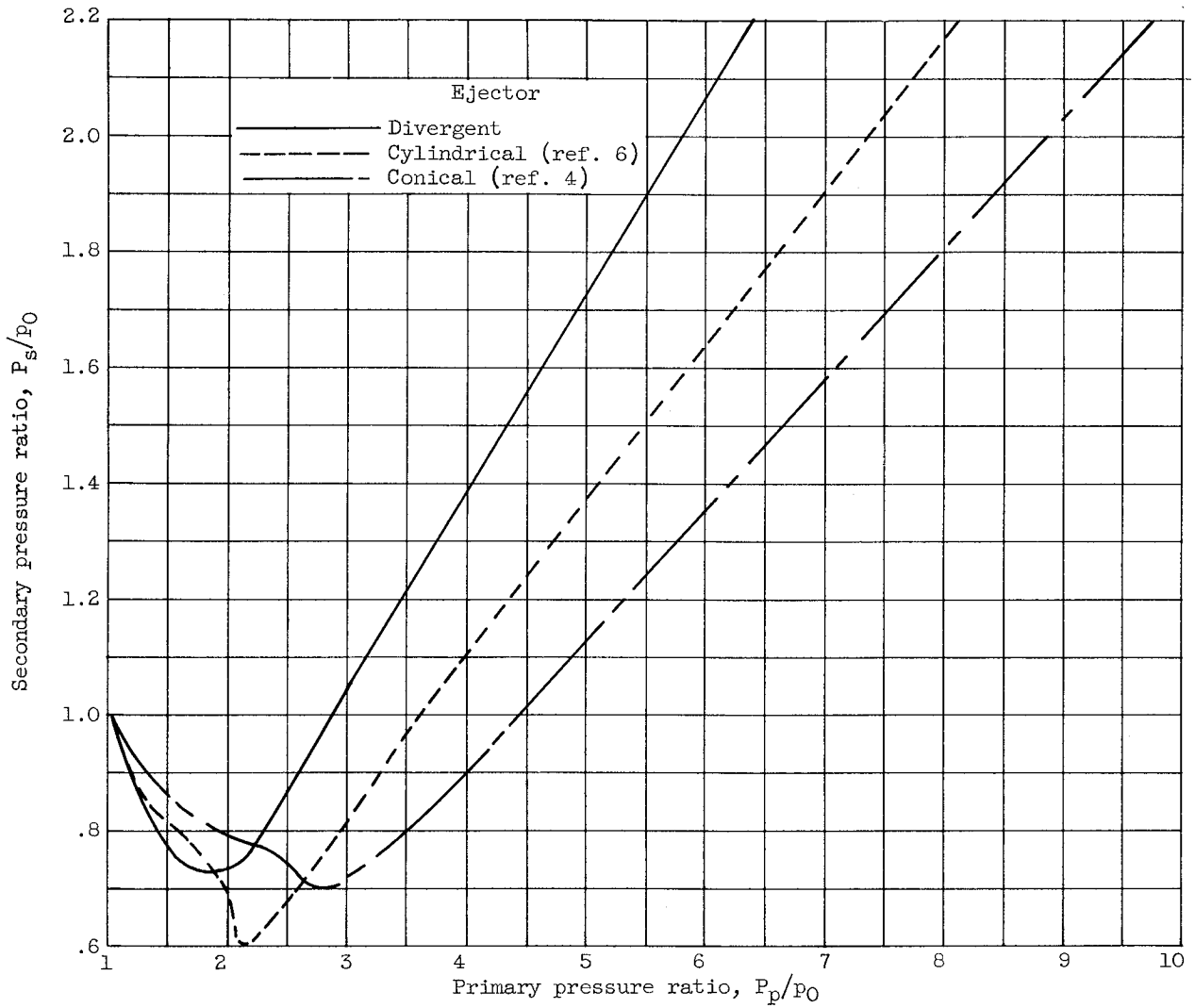

(d) Corrected weight-flow ratio, 0.03; spacing ratio, 1.6.

Figure 9. - Continued. Comparison of pumping characteristics of several ejectors. Exit-diameter ratio, 1.2.

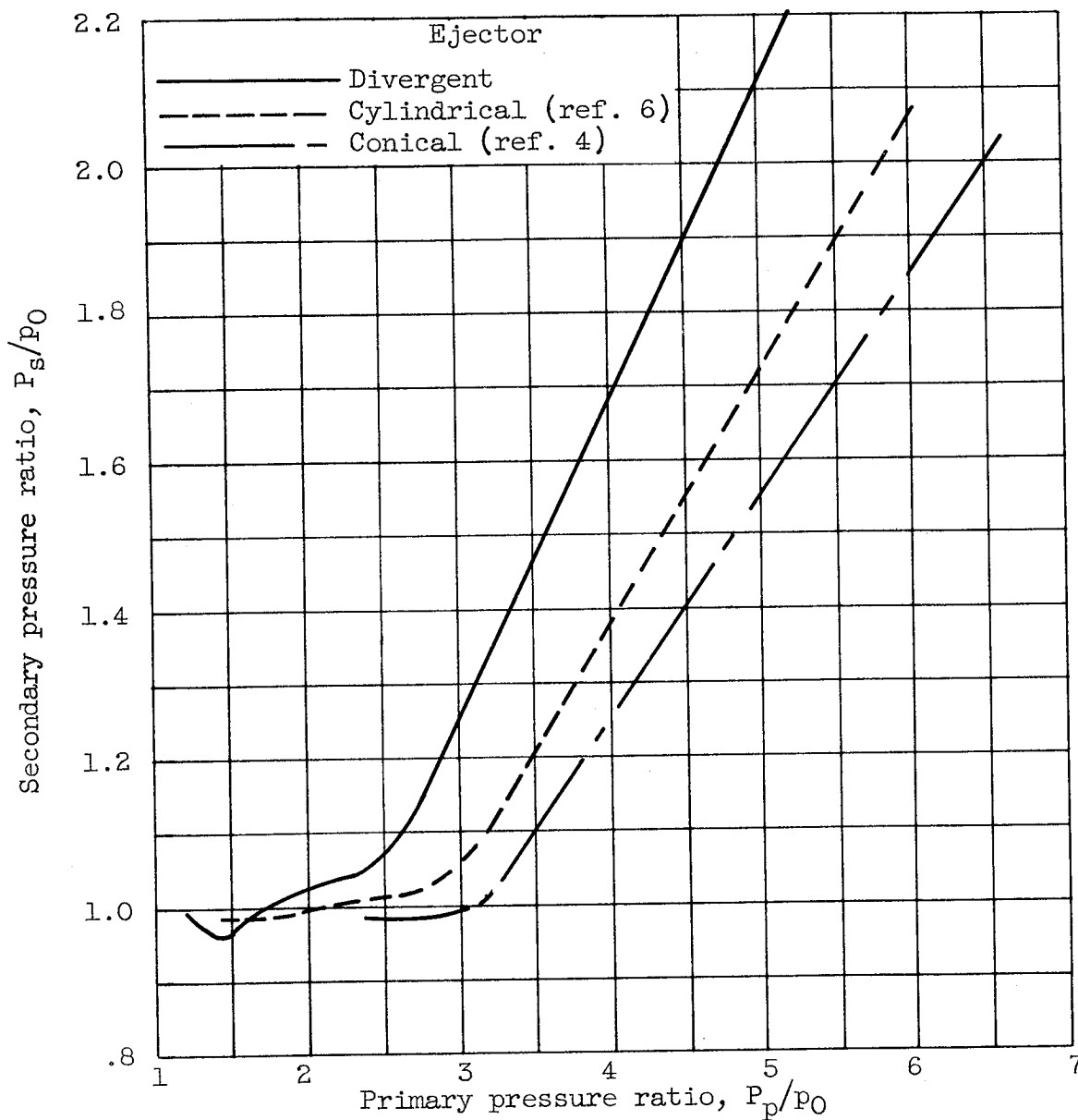

(e) Corrected weight-flow ratio, 0.07; spacing ratio, 0.9.

Figure 9. - Continued. Comparison of pumping characteristics of several ejectors. Exit-diameter ratio, 1.2.

2912

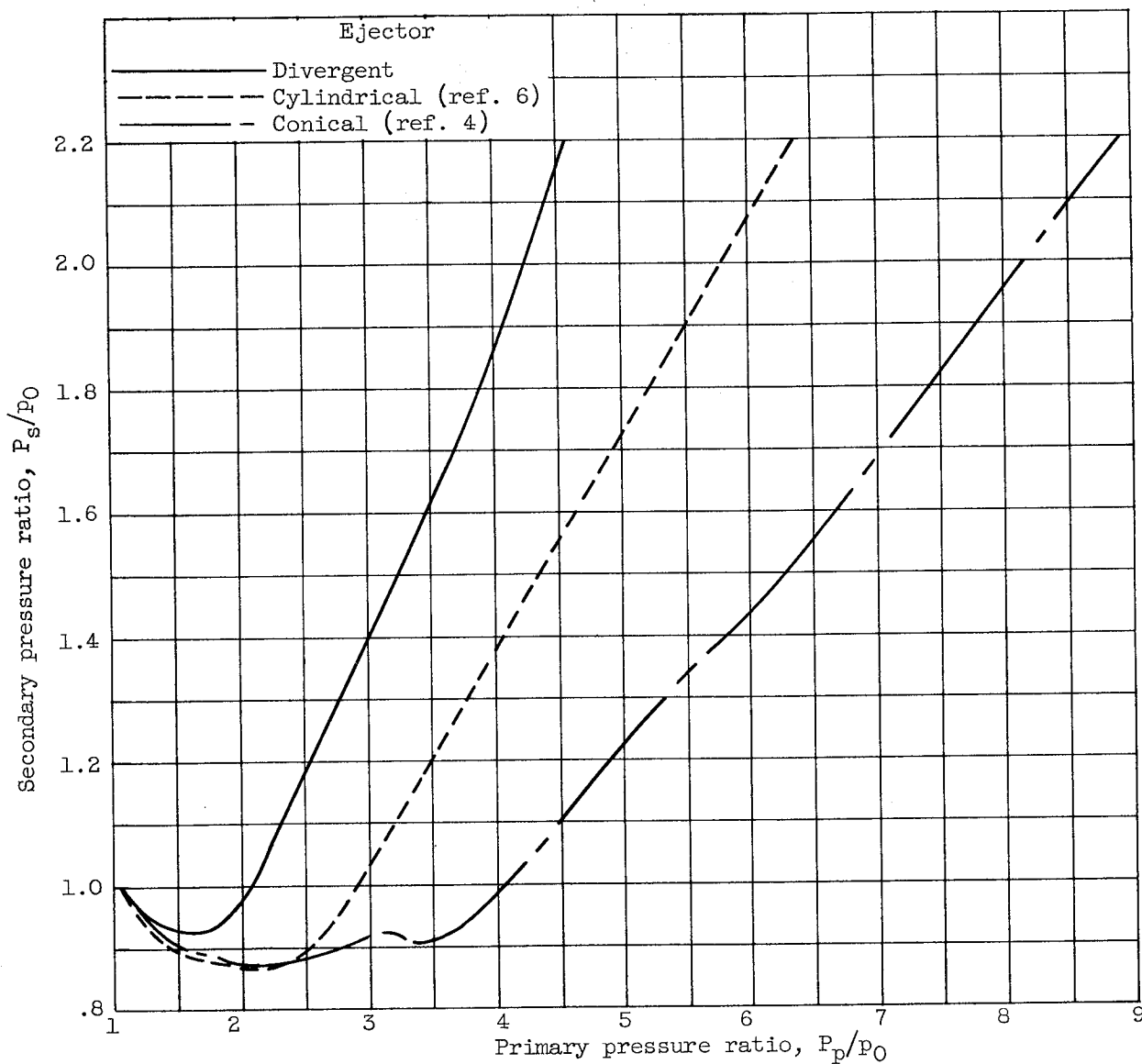

(f) Corrected weight-flow ratio, 0.07; spacing ratio, 1.6.

Figure 9. - Concluded. Comparison of pumping characteristics of several ejectors. Exit-diameter ratio, 1.2.

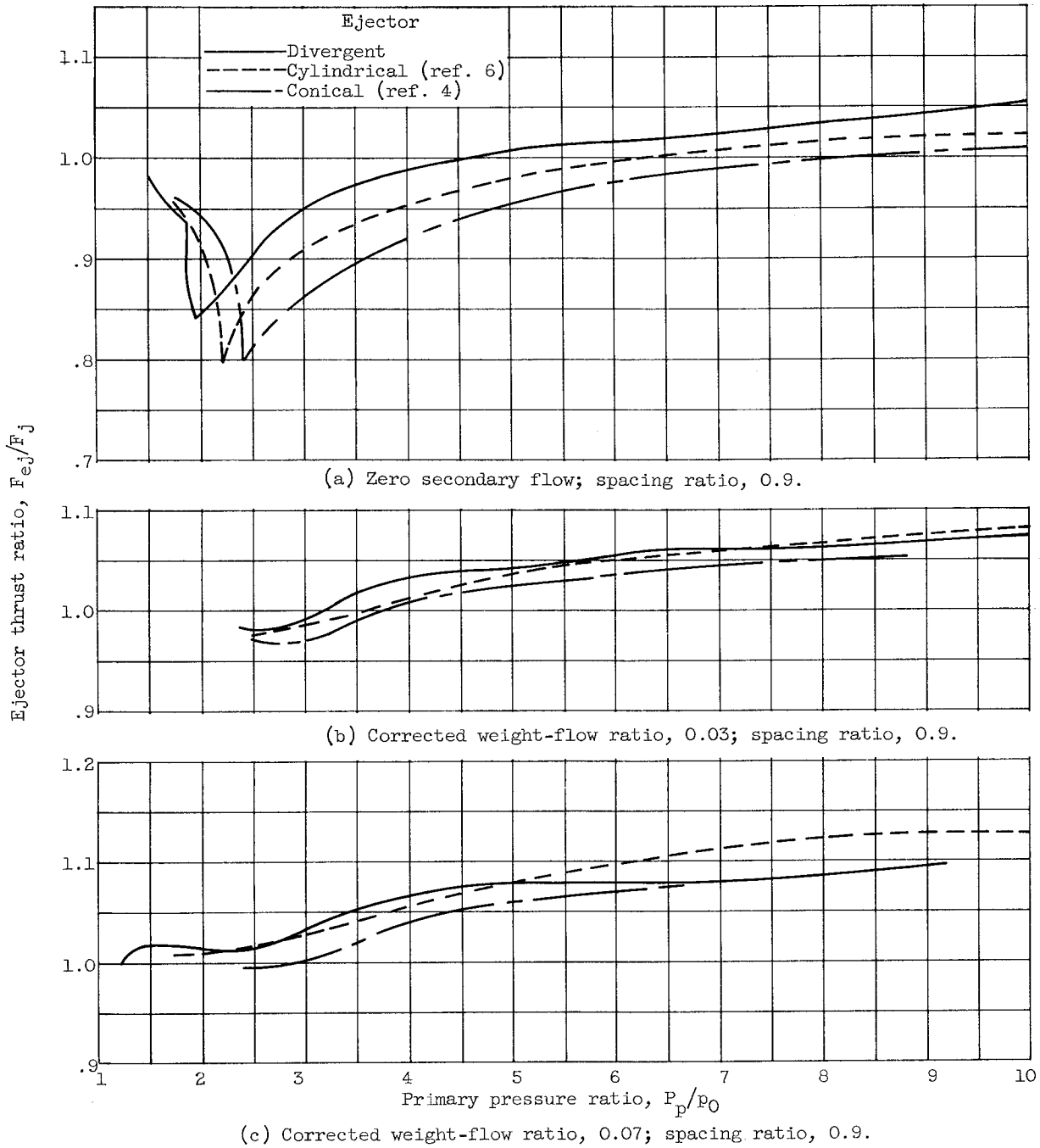

Figure 10. - Comparison of thrust characteristics of several ejectors. Exit-diameter ratio, 1.2.

2912

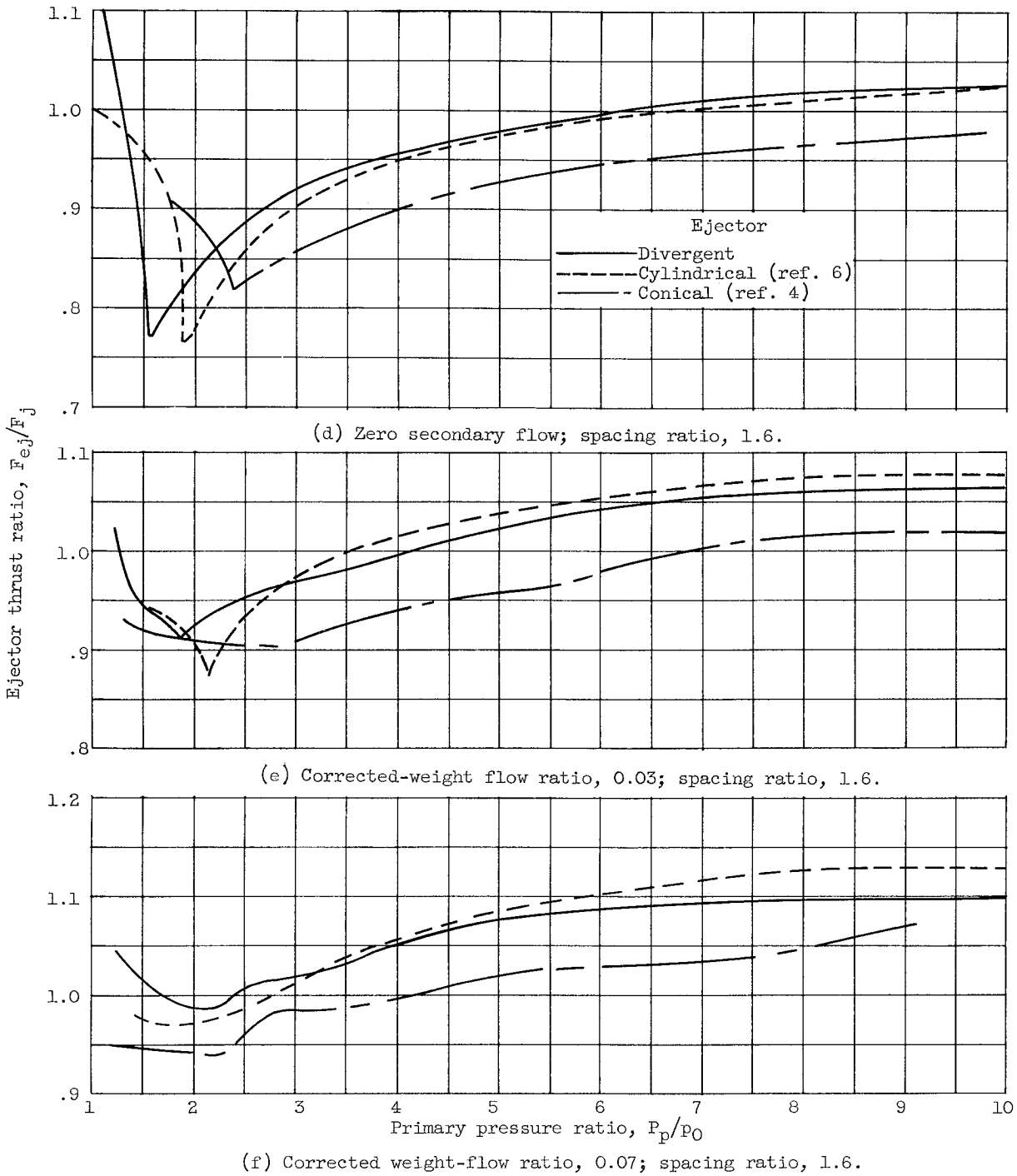
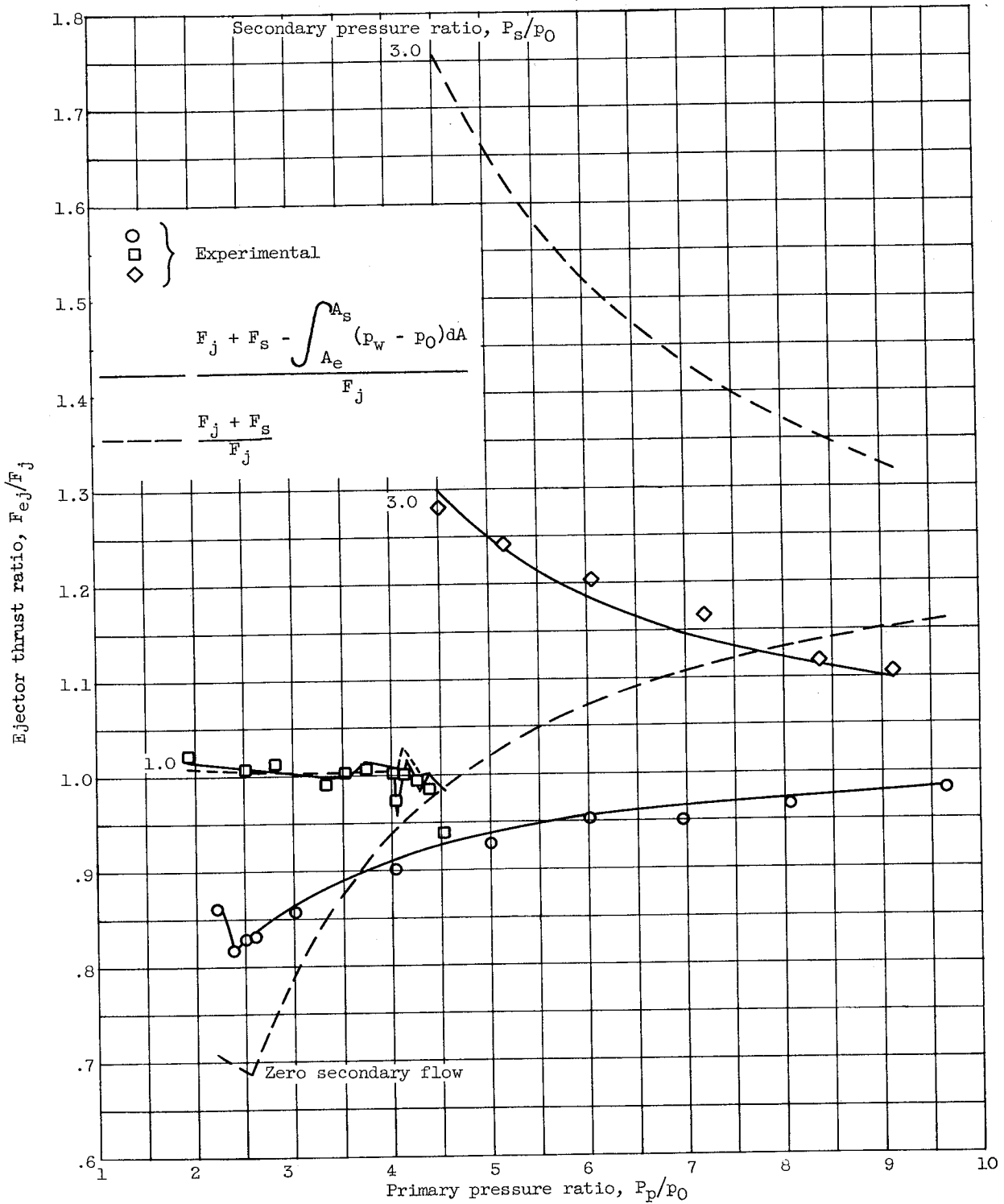
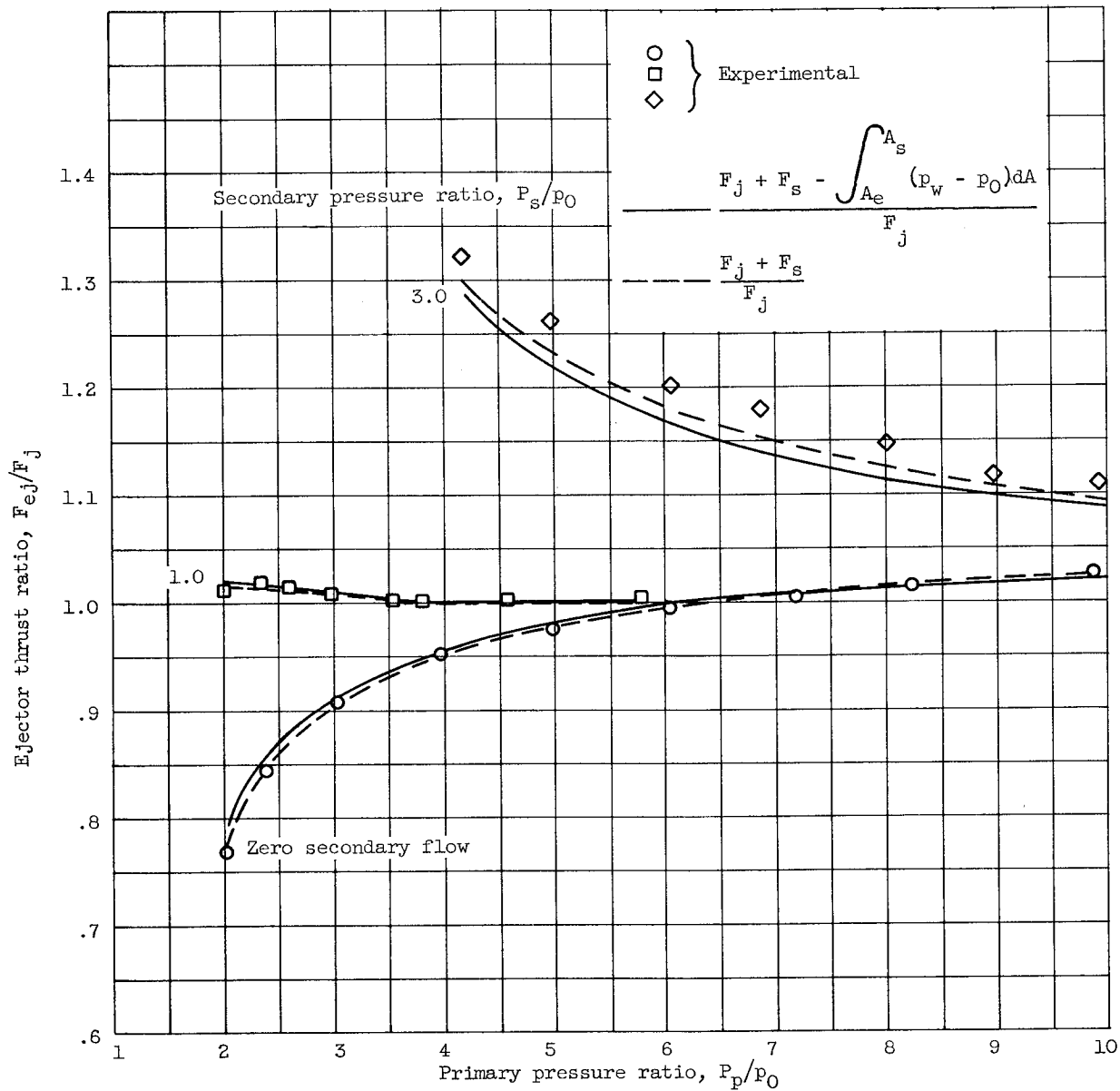

Figure 10. - Concluded. Comparison of thrust characteristics of several ejectors. Exit-diameter ratio, 1.2.



(a) Conical.

Figure 11. - Comparison of thrust characteristics of several ejectors. Exit-diameter ratio, 1.2; spacing ratio, 1.6.



(b) Cylindrical.

Figure 11. - Continued. Comparison of thrust characteristics of several ejectors. Exit-diameter ratio, 1.2; spacing ratio, 1.6.

2912

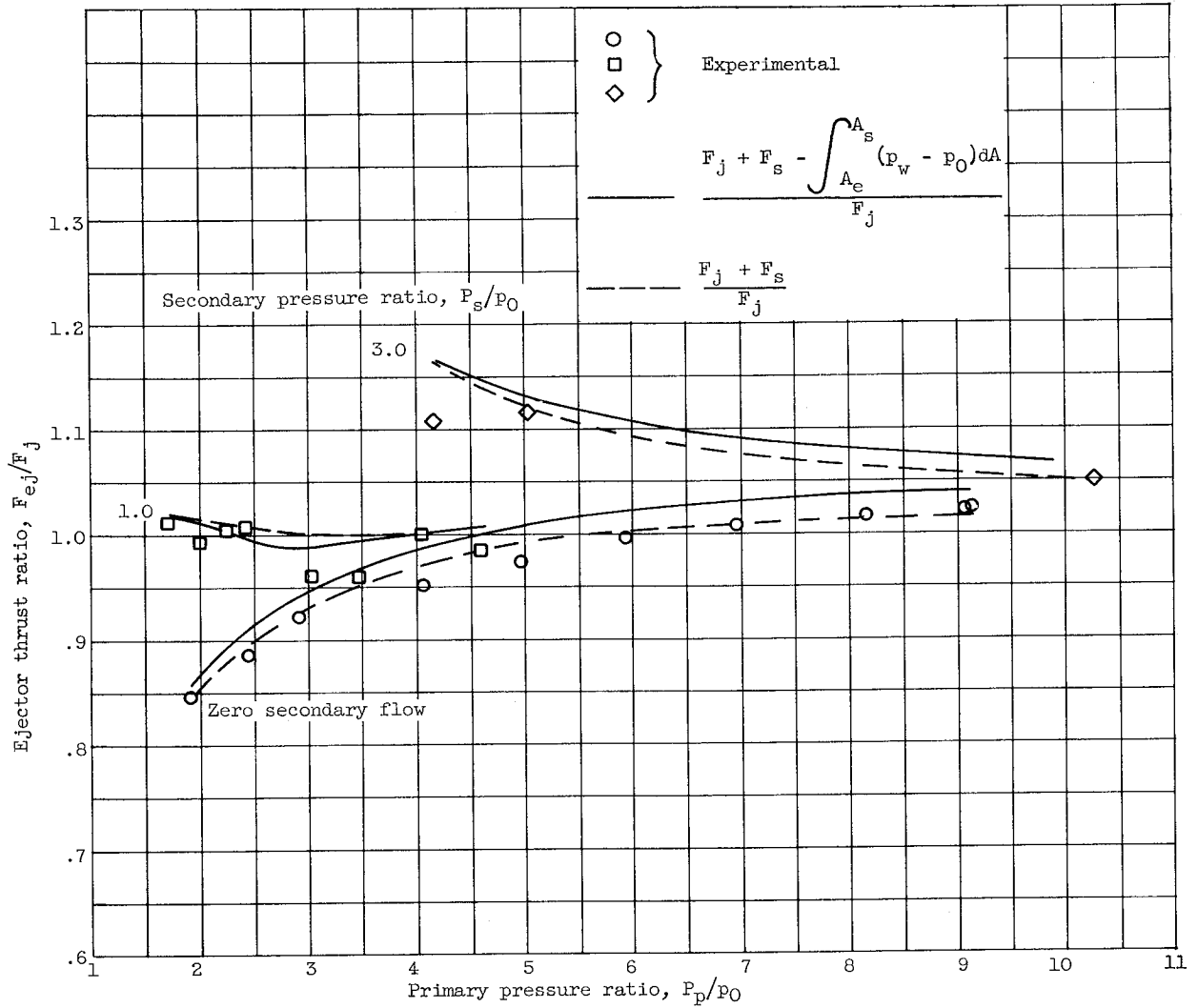

(c) Divergent.

Figure 11. - Concluded. Comparison of thrust characteristics of several ejectors. Exit-diameter ratio, 1.2; spacing ratio, 1.6.

NACA RM E53J13

National Advisory Committee for Aeronautics.
PUMPING AND THRUST CHARACTERISTICS OF SEVERAL DIVERGENT COOLING-AIR EJECTORS AND COMPARISON OF PERFORMANCE WITH CONICAL AND CYLINDRICAL EJECTORS. S. C. Huntley and Herbert Yanowitz. January 1954. 42p. diags. (NACA RM E53J13) **CONFIDENTIAL**

An investigation was made of the performance of four divergent ejectors having shroud-exit to primary-nozzle-exit diameter ratios of 1.2 and 1.3 with minimum-shroud to primary-nozzle-exit diameter ratios of 1.1 and 1.2, respectively, and spacing ratios of 0.87 and 1.6. A comparison of the performance of conical, cylindrical, and divergent ejectors showed that on the basis of similar design variables (exit-diameter ratio and spacing ratio) each configuration has merit. At an exit-diameter ratio of 1.2 and spacing ratios of 0.9 and 1.6, the divergent ejector had the highest thrust at zero secondary flow.

Copies obtainable from NACA, Washington (over)

CONFIDENTIAL

1. Flow, Compressible (1. 1. 2)
 2. Pumps, Jet and Thrust Augmentors (1. 4. 4)
 3. Cooling - Gas-Turbine Systems (3. 10. 2)
- I. Huntley, Sidney C.
 II. Yanowitz, Herbert
 III. NACA RM E53J13

**NACA RM E53J13**

National Advisory Committee for Aeronautics.
PUMPING AND THRUST CHARACTERISTICS OF SEVERAL DIVERGENT COOLING-AIR EJECTORS AND COMPARISON OF PERFORMANCE WITH CONICAL AND CYLINDRICAL EJECTORS. S. C. Huntley and Herbert Yanowitz. January 1954. 42p. diags. (NACA RM E53J13) **CONFIDENTIAL**

An investigation was made of the performance of four divergent ejectors having shroud-exit to primary-nozzle-exit diameter ratios of 1.2 and 1.3 with minimum-shroud to primary-nozzle-exit diameter ratios of 1.1 and 1.2, respectively, and spacing ratios of 0.87 and 1.6. A comparison of the performance of conical, cylindrical, and divergent ejectors showed that on the basis of similar design variables (exit-diameter ratio and spacing ratio) each configuration has merit. At an exit-diameter ratio of 1.2 and spacing ratios of 0.9 and 1.6, the divergent ejector had the highest thrust at zero secondary flow.

Copies obtainable from NACA, Washington (over)

CONFIDENTIAL

1. Flow, Compressible (1. 1. 2)
 2. Pumps, Jet and Thrust Augmentors (1. 4. 4)
 3. Cooling - Gas-Turbine Systems (3. 10. 2)
- I. Huntley, Sidney C.
 II. Yanowitz, Herbert
 III. NACA RM E53J13

**NACA RM E53J13**

National Advisory Committee for Aeronautics.
PUMPING AND THRUST CHARACTERISTICS OF SEVERAL DIVERGENT COOLING-AIR EJECTORS AND COMPARISON OF PERFORMANCE WITH CONICAL AND CYLINDRICAL EJECTORS. S. C. Huntley and Herbert Yanowitz. January 1954. 42p. diags. (NACA RM E53J13) **CONFIDENTIAL**

An investigation was made of the performance of four divergent ejectors having shroud-exit to primary-nozzle-exit diameter ratios of 1.2 and 1.3 with minimum-shroud to primary-nozzle-exit diameter ratios of 1.1 and 1.2, respectively, and spacing ratios of 0.87 and 1.6. A comparison of the performance of conical, cylindrical, and divergent ejectors showed that on the basis of similar design variables (exit-diameter ratio and spacing ratio) each configuration has merit. At an exit-diameter ratio of 1.2 and spacing ratios of 0.9 and 1.6, the divergent ejector had the highest thrust at zero secondary flow.

Copies obtainable from NACA, Washington (over)

CONFIDENTIAL

1. Flow, Compressible (1. 1. 2)
 2. Pumps, Jet and Thrust Augmentors (1. 4. 4)
 3. Cooling - Gas-Turbine Systems (3. 10. 2)
- I. Huntley, Sidney C.
 II. Yanowitz, Herbert
 III. NACA RM E53J13

**NACA RM E53J13**

National Advisory Committee for Aeronautics.
PUMPING AND THRUST CHARACTERISTICS OF SEVERAL DIVERGENT COOLING-AIR EJECTORS AND COMPARISON OF PERFORMANCE WITH CONICAL AND CYLINDRICAL EJECTORS. S. C. Huntley and Herbert Yanowitz. January 1954. 42p. diags. (NACA RM E53J13) **CONFIDENTIAL**

An investigation was made of the performance of four divergent ejectors having shroud-exit to primary-nozzle-exit diameter ratios of 1.2 and 1.3 with minimum-shroud to primary-nozzle-exit diameter ratios of 1.1 and 1.2, respectively, and spacing ratios of 0.87 and 1.6. A comparison of the performance of conical, cylindrical, and divergent ejectors showed that on the basis of similar design variables (exit-diameter ratio and spacing ratio) each configuration has merit. At an exit-diameter ratio of 1.2 and spacing ratios of 0.9 and 1.6, the divergent ejector had the highest thrust at zero secondary flow.

Copies obtainable from NACA, Washington (over)

CONFIDENTIAL

1. Flow, Compressible (1. 1. 2)
 2. Pumps, Jet and Thrust Augmentors (1. 4. 4)
 3. Cooling - Gas-Turbine Systems (3. 10. 2)
- I. Huntley, Sidney C.
 II. Yanowitz, Herbert
 III. NACA RM E53J13



With corrected weight-flow ratios of 0.03 and 0.07, the divergent ejector had the highest thrust at low primary pressure ratios, while the cylindrical ejector had the highest thrust at high primary pressure ratios. The range of primary pressure ratio over which the cylindrical ejector was advantageous in thrust increased for both the higher corrected weight-flow ratio and the larger spacing ratio. The conical ejector, however, can pump a given corrected weight flow over a wider range of primary pressure ratio but at the expense of a relatively low ejector thrust. The divergent ejector had the smallest range of primary pressure ratio for a given corrected weight-flow ratio. The possibility of obtaining ejector thrust performance from a simple one-dimensional equation by using a measurement of wall pressure distribution was illustrated.

With corrected weight-flow ratios of 0.03 and 0.07, the divergent ejector had the highest thrust at low primary pressure ratios, while the cylindrical ejector had the highest thrust at high primary pressure ratios. The range of primary pressure ratio over which the cylindrical ejector was advantageous in thrust increased for both the higher corrected weight-flow ratio and the larger spacing ratio. The conical ejector, however, can pump a given corrected weight flow over a wider range of primary pressure ratio but at the expense of a relatively low ejector thrust. The divergent ejector had the smallest range of primary pressure ratio for a given corrected weight-flow ratio. The possibility of obtaining ejector thrust performance from a simple one-dimensional equation by using a measurement of wall pressure distribution was illustrated.

Copies obtainable from NACA, Washington

Copies obtainable from NACA, Washington



With corrected weight-flow ratios of 0.03 and 0.07, the divergent ejector had the highest thrust at low primary pressure ratios, while the cylindrical ejector had the highest thrust at high primary pressure ratios. The range of primary pressure ratio over which the cylindrical ejector was advantageous in thrust increased for both the higher corrected weight-flow ratio and the larger spacing ratio. The conical ejector, however, can pump a given corrected weight flow over a wider range of primary pressure ratio but at the expense of a relatively low ejector thrust. The divergent ejector had the smallest range of primary pressure ratio for a given corrected weight-flow ratio. The possibility of obtaining ejector thrust performance from a simple one-dimensional equation by using a measurement of wall pressure distribution was illustrated.

With corrected weight-flow ratios of 0.03 and 0.07, the divergent ejector had the highest thrust at low primary pressure ratios, while the cylindrical ejector had the highest thrust at high primary pressure ratios. The range of primary pressure ratio over which the cylindrical ejector was advantageous in thrust increased for both the higher corrected weight-flow ratio and the larger spacing ratio. The conical ejector, however, can pump a given corrected weight flow over a wider range of primary pressure ratio but at the expense of a relatively low ejector thrust. The divergent ejector had the smallest range of primary pressure ratio for a given corrected weight-flow ratio. The possibility of obtaining ejector thrust performance from a simple one-dimensional equation by using a measurement of wall pressure distribution was illustrated.

Copies obtainable from NACA, Washington

Copies obtainable from NACA, Washington

