

CONFIDENTIAL

RM A54F21

NACA RM A54F21

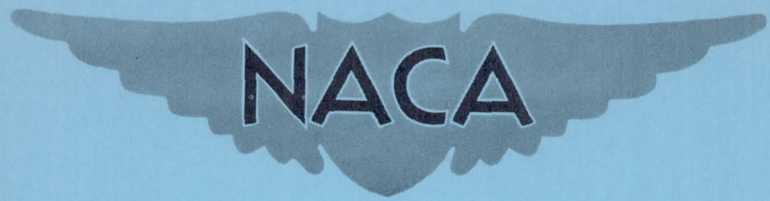

RESEARCH MEMORANDUM

FLIGHT INVESTIGATION OF THE EFFECTS OF HORIZONTAL-TAIL HEIGHT,
MOMENT OF INERTIA, AND CONTROL EFFECTIVENESS ON THE
PITCH-UP CHARACTERISTICS OF A 35° SWEEP-WING
FIGHTER AIRPLANE AT HIGH SUBSONIC SPEEDS

By Norman M. McFadden and Donovan R. Heinle

Ames Aeronautical Laboratory
Moffett Field, Calif.

CLASSIFIED DOCUMENT

This material contains information affecting the National Defense of the United States within the meaning of the espionage laws, Title 18, U.S.C., Secs. 793 and 794, the transmission or revelation of which in any manner to an unauthorized person is prohibited by law.

NATIONAL ADVISORY COMMITTEE FOR AERONAUTICS

WASHINGTON

January 18, 1955

CLASSIFICATION CHANGED TO UNCLASSIFIED
AUTHORITY: NACA RESEARCH ABSTRACT NO. 116
EFFECTIVE DATE: JUNE 20, 1957

CONFIDENTIAL

NATIONAL ADVISORY COMMITTEE FOR AERONAUTICS

RESEARCH MEMORANDUMFLIGHT INVESTIGATION OF THE EFFECTS OF HORIZONTAL-TAIL HEIGHT,
MOMENT OF INERTIA, AND CONTROL EFFECTIVENESS ON THE
PITCH-UP CHARACTERISTICS OF A 35° SWEEP-WING
FIGHTER AIRPLANE AT HIGH SUBSONIC SPEEDS

By Norman M. McFadden and Donovan R. Heinle

SUMMARY

A flight investigation was conducted of a 35° swept-wing fighter airplane with two different horizontal-tail heights. The longitudinal stability and buffet characteristics were compared for the two configurations. The pilots' opinions of the pitch-up characteristics of the test airplane were compared with those of another version of the 35° swept-wing fighter, and calculations were made correlating the differences in pitch-up characteristics with the differences in control effectiveness and moment of inertia of the two airplanes.

Lowering the tail the amount possible on the test airplane had only a very small effect on the longitudinal stability characteristics. Lowering the tail made no appreciable change in the buffet boundary of the test airplane since there was no marked increase in buffeting as the tail entered the wing wake.

Analysis showed that the substantial improvement in the pitch-up characteristics of the test airplane over those of another version of the 35° swept-wing fighter was due to a large extent to the increased control effectiveness, an increased moment of inertia, and a decreased change of control effectiveness with change in Mach number of the test airplane.

INTRODUCTION

The use of sweptback wings to improve performance in the transonic speed range has introduced the problem of pitch-up - a longitudinal

instability which occurs at high speeds at lift coefficients well below maximum lift. Factors which can affect the severity (and pilot opinion) of the pitch-up are the wing-fuselage pitching moment, the moment contributed by the horizontal tail (including downwash effects), the pilot's control power, the aerodynamic damping, and the moment of inertia of the airplane. References 1 and 2 have shown that for the F-86A, a 35° swept-wing fighter airplane, this instability was due to an abrupt break in the wing-fuselage pitching-moment curve resulting from a premature wing-tip stall. The downwash at the horizontal-tail position was not changed significantly by the inboard shift in the span load.

Earlier wind-tunnel tests by North American Aviation, Inc., showed that low tail locations produced decided improvements in static longitudinal stability. More recent high Mach number tests (refs. 3 to 5) have indicated that horizontal-tail locations in or below the wing-chord plane balance to a large extent the unstable wing-fuselage pitching moments associated with the pitch-up. When it became possible to obtain a swept-wing fighter airplane with two alternative tail configurations (horizontal tail 0.202 $b/2$ and 0.081 $b/2$ above the wing-chord plane), the investigation reported herein was undertaken. Although there were no data available directly applicable to the configuration of the test vehicle, examination of reference 3 indicated a possibility of obtaining a significant reduction in aerodynamic center shift during the pitch-up by the use of the low tail configuration. Reference 6, a wind-tunnel test run concurrently with the present investigation, also indicated the possibilities of substantial gains by lowering the tail on a 35° swept-wing airplane.

The pilot, of course, is not directly sensitive to the instabilities of the pitching moment of the airplane, but only to the resultant motions of the airplane and to the control motions and forces required to maneuver. A study of reference 7 shows that if the pilot were given a sufficiently powerful control and time to apply it by having an airplane with very slow response to changes in pitching moment, the airplane could be controlled with ease regardless of the severity of the instability.

For low tail installations, there is the possibility of airframe buffeting being induced by unsteady flow over the horizontal tail as the tail enters the wake of the wing. This is of particular importance in the transonic speed region where shock-induced separation of the flow over the wing occurs.

The primary purpose of this report was to compare the pitch-up characteristics of the test airplane with the two different tail configurations and, in turn, to compare these results with those that might be predicted from static wind-tunnel tests. A secondary purpose was to investigate the effect on airframe buffeting of allowing the horizontal tail to enter the wing wake.

In another phase of the investigation reported herein the pilots' opinions of the pitch-up characteristics of the test airplane were compared with their opinions of the test airplane of reference 1. The latter airplane had one third the control effectiveness and two thirds the moment of inertia of the present test airplane and had an identical wing plan form.

NOTATION

A_z	normal acceleration factor, $\frac{\text{lift}}{\text{weight}}$
ΔA_z	buffet induced increments in normal acceleration at the airplane center of gravity
b	wing span
\bar{c}	mean aerodynamic chord
C_L	lift coefficient, $\frac{\text{lift}}{qS}$
C_m	pitching-moment coefficient, $\frac{\text{pitching moment}}{qS\bar{c}}$
C_N	normal-force coefficient, $\frac{\text{normal force}}{qS}$
g	acceleration due to gravity
Δh	loss in total pressure
i_t	stabilizer incidence
I_y	moment of inertia about lateral axis through the center of gravity
l_t	tail length
L_t	tail load
M	Mach number
q	dynamic pressure, $\frac{1}{2}\rho V^2$
S	wing area
t	time
V	flight velocity
α	angle of attack

δ_e	elevator angle
$\ddot{\theta}$	pitching acceleration
ρ	air density

Subscripts

bal	balancing
w+f	wing plus fuselage

EQUIPMENT AND TESTS

Test Airplane

The test airplane used in this investigation was a YF-86D, a 35° swept-wing fighter (fig. 1 and table I). The airplane was equipped with an all-movable, irreversible, power-actuated horizontal tail with artificial stick forces fed back to the pilot. The airplane was furnished with two rear fuselage sections containing different horizontal-tail installations. One with the standard F-86D tail installed 0.202 $b/2$ above the wing-chord plane, the other had the identical tail installed 0.081 $b/2$ above the wing-chord plane. On the basis of the wind-tunnel data (refs. 3 to 6), it would have been advisable to locate the low tail installation much lower (wing-chord plane or below); however, it was not feasible to do so on the test airplane.

Instrumentation and Tests

The test airplane was instrumented with standard NACA instruments and an 18-channel oscillograph to measure the following quantities:

1. horizontal-tail loads (low-tail version only)
2. airspeed
3. altitude
4. normal and longitudinal acceleration of center of gravity
5. angular velocity and acceleration (three components)
6. stabilizer position
7. angle of attack
8. differential total pressure (tips of horizontal and vertical tails)

The flight tests consisted of making turns at constant Mach number, gradually increasing the normal acceleration until a high-speed stall was encountered. It was necessary to progressively increase the dive angle of the airplane to maintain speed as the normal acceleration was increased. Runs were made over a Mach number range of 0.70 to 0.95 at 35,000 feet altitude.

Corrections

At times the pitching acceleration was large enough that the data could not be considered to have been taken under static conditions, in spite of the pilot's attempts to maintain a low rate-of-change normal acceleration. Therefore the measured stabilizer angle was corrected for pitching acceleration by

$$\Delta i_t = \frac{I_y \ddot{\theta}}{qS\bar{c}} \frac{1}{dC_m/di_t}$$

where dC_m/di_t , shown in figure 2, was obtained from elevator pulse tests as described in reference 8. The balancing tail loads were corrected for pitching acceleration by

$$\Delta L_{t_{bal}} = \frac{I_y \ddot{\theta}}{l_t}$$

No corrections were applied for flight-path curvature because such corrections are relatively small at the speeds of the flight tests.

All data were corrected to a center-of-gravity position of 22-1/4 percent M.A.C.

RESULTS AND DISCUSSION

Longitudinal Stability

Figure 3 presents the stabilizer angle required to balance the airplane as a function of the normal-force coefficient for several constant Mach number runs (Mach number changes restricted to 0.01). Data are not presented for speeds above a Mach number of 0.91 because of the difficulty of holding the speed constant as the normal acceleration was increased. At Mach numbers of 0.88 and 0.85 the curve for the low-tail configuration had a slightly smaller unstable break which came

at a little higher normal-force coefficient. This indicated that a less severe pitch-up would be expected with the low-tail airplane. However, at Mach numbers of 0.80 and 0.91 the data indicated that the low-tail configuration would be expected to have a slightly more severe pitch-up. In any case, the differences in stability represented by the curves of figure 3 were relatively small and did not represent an appreciable change in stability, as evidenced by the fact that the pilots were unable to notice a difference in the pitch-up characteristics with the two tail configurations.

The investigation reported in reference 6 showed that, at Mach numbers of 0.85 and below, changing the tail height the amount used in this investigation changed the pitching-moment curve from one with an unstable break to one that broke only to neutral stability. At Mach numbers of 0.90 and 0.92 the break was to neutral stability for both tail configurations. The model had a similar wing plan form and the identical tail heights of the present test airplane, but had a different airfoil section, fuselage, tail plan form, tail length, and the Reynolds number was 2,000,000 compared to a range of 13,600,000 to 18,000,000 for the flight tests. Figure 3 has shown that, with the exception of Mach numbers of 0.855 and 0.880 for the high tail, the curves broke to neutral stability for both tail configurations with the present test vehicle. This difference in results for the two tests indicates that care must be exercised when wind-tunnel tests are interpreted if the wind-tunnel model is not an exact duplicate of the configuration being studied.

Although there were no beneficial effects found from lowering the tail to $0.081 b/2$ above the wing-chord plane, there is no reason to believe that there would not be some advantages found if it were possible to place the horizontal tail in or below the wing-chord plane as shown to be desirable in references 3 to 5.

Buffet

The buffet boundary of the test airplane is shown in figure 4 for both tail configurations. The normal-force coefficient at which the tail entered the wake (as evidenced by loss in total head at the tip of the stabilizer) is also included in the figure. The buffet boundary of the test airplane of reference 1 was presented in reference 9, and is added for comparison purposes. That airplane had an identical plan form and a slightly higher tail location ($0.02 b/2$) and longer tail length ($2-1/2$ feet) than the high-tail configuration of the present test airplane. It is evident that there is no correlation between the buffet boundary and the tail entry into the wing wake. The buffet boundary of the airplane of the present tests is almost identical for the two tail configurations and, except at the very lowest Mach numbers,

occurred at lower normal-force coefficient than that at which the tail entered the wing wake. There is also close agreement with the buffet boundary of the airplane of reference 1.

Above a Mach number of 0.90 there was a mild buffeting in level flight with either tail configuration. This buffeting increased gradually with an increase in normal-force coefficient but seemed to have no marked increase as the tail entered the wake of the wing. Figure 5 presents a reproduction of the center-of-gravity accelerometer record of a pitch-up at a Mach number of 0.92. Plotted in the same figure is a record of the total head at the tip of the stabilizer and values of normal acceleration represented by the accelerometer record. The increase in buffeting shown at 7 seconds does start while the tail is in the wing wake, but it is felt that this is wing buffeting due to the lift starting to decrease at this time - decreasing lift having a destabilizing effect on the boundary layer in contrast to the effect of increasing lift just prior to time 7 seconds. The larger values of buffeting continue after the tail has emerged from the wing wake, thus eliminating the effect of the wake on the tail as a possible source of the buffeting. The primary source of the mild buffeting at low lifts is believed to be the separation near the fuselage-tail juncture. Figure 6 shows tuft pictures for the low-tail installation at a Mach number of 0.94, a normal-force coefficient of 0.090 - an A_z of slightly less than $1/2$ - and for the high-tail configuration at a Mach number of 0.905 and an A_z of 1.

Pitch-Up Intensity

Pilots' opinions.- During the course of this investigation the pilots found almost no noticeable change in the pitch-up intensity with change in tail location, but the pitch-up of the airplane of the present investigation was very mild compared to that of the airplane of reference 1. The two airplanes had identical wing plan forms and similar tail plan forms. However, the tail of the airplane of reference 1 was slightly higher, further aft, and had less area. This resulted in an increase in tail height of $0.02 b/2$, a 20-percent increase in tail length, and a decrease in area of 33 percent.

The detection of a pitch-up was obscured, from the pilots' point of view, by differences in control sensitivity and in stick-free stability of the two airplanes. The test airplane of this investigation had the earliest version of the irreversible power-operated slab tail and had a definite control sensitivity problem. It was very difficult, if not impossible, for the pilot to maneuver the airplane smoothly, and almost invariably there was a short-period longitudinal oscillation imposed upon whatever maneuver the pilot was attempting (fig. 5) that

had a tendency to mask the effects of the pitch-up. As a result of this, the pilots, before becoming accustomed to the peculiarities of the control system, would report that there was no pitch-up with the airplane. However, after becoming familiar with the control system the pilots could detect a pitch-up, but were able to control the airplane in the pitch-up region in spite of the sensitivity problem. On the other hand, with the airplane of reference 1, it was impossible to control the airplane in the pitch-up region and very rapid action was required to prevent the airplane from pitching up to the stall when the instability was encountered while flying above the buffet boundary.

The pilots also felt that the better stick-free stability of the airplane of the present tests, which did not deteriorate at the higher Mach numbers because of the purely artificial feel system, had considerable bearing on the rate at which the pilot could apply corrective control. It was only necessary to ease up on the back pressure on the stick - reversal of stick force to get corrective control was not required.

In addition to these differences which tended to affect pilot response, there were several differences in the two airplanes that also might affect the pitch-up characteristics. Affecting the difference in response of the airplanes at constant Mach number were two factors: the elevator effectiveness of the airplane of reference 1 was only one third of the stabilizer effectiveness of the airplane of the present tests, and the moment of inertia was only two thirds of that of the present test airplane. Another factor, which can have a powerful effect on the pitch-up when changes in speed are involved (which is the usual case), was the change in control effectiveness with change in Mach number which was much larger with the airplane of reference 1 (fig. 2). There was also the possibility that differences in airframe and control-surface stiffness might have some effect on the basic pitching moment of the airplanes.

Wing-fuselage pitching moments.- Figure 7 compares the wing-fuselage pitching moments of the two airplanes. It can be seen that the break in the curves (indicating the pitch-up) was equally abrupt in both cases and generally came at the same normal-force coefficient for both airplanes. Other than the slightly higher normal-force coefficient reached by the present test airplane before reaching the instability at a Mach number of 0.89, the longitudinal stability characteristics represented by the wing-fuselage pitching moment were very similar for both airplanes.

Control effectiveness and moment of inertia differences.- Since it was shown by the data of figure 7 that no difference existed in the wing-fuselage pitching moments that could reasonably account for the difference in the pitch-up of the two airplanes reported by the pilots,

calculations were made to determine the possible effects of the increased control effectiveness and moment of inertia of the present test airplane. Using a modified version of the method of reference 7 a series of calculations was performed using the airplane of reference 1 as a sample. These were made in order to show the differences which might be expected in the pitch-up characteristics of that airplane as a result of variations of the control effectiveness and moment of inertia. For these calculations, the results of which are presented in figure 8, a steady elevator input of 1° per second was used until $1/2$ second after the pitch-up (as evidenced by the slope of the pitching-moment curve going positive), followed by a recovery using a 10° per second elevator input rate. Time histories of angles of attack were calculated for three values of control effectiveness and two values of moment of inertia. An additional calculation was performed using the largest values of both control effectiveness and moment of inertia. These were roughly equivalent to the values actually found in the airplane of the present tests. As a reference, a calculation was made using the values of control effectiveness and moment of inertia corresponding to the airplane of reference 1, but assuming the pitching moment to be linear ($dC_m/d\alpha = \text{constant}$) with the slope equal to the slope in the low angle-of-attack range of the pitching moment used in the initial calculations. Initial conditions were chosen such that $1/2$ second before the corrective control was applied (corresponding to the initial instability in the previous calculations), the airplane was in trim with the values of angle of attack and of rate of change of angle of attack equal to those obtained in the previous calculations at the onset of the pitch-up. The initial rate of change of angle of attack in this calculation was much higher than that compatible with the rate of elevator input. Thus the calculated rate of change of angle of attack started to decrease before corrective control was applied. Nevertheless, this curve serves as a good base from which to compare the overshoot of angle of attack found for the other conditions.

Either the increased control effectiveness or the increased moment of inertia reduced the overshoot (using the linear pitching-moment case as a reference) by 60 percent, and the combination of the two reduced the overshoot by 80 percent.

This result was not entirely in agreement with the results of reference 7, which showed little or no effect of control effectiveness (which is equivalent to rate of corrective control in the calculations) on the pitch-up. The difference lies in the particular situations analyzed. In reference 7 much larger rates of entry into the pitch-up in terms of rate of change of angle of attack were used and the recovery was delayed one full second after the initiation of the pitch-up. This allowed the airplane to pitch completely through the unstable region before recovery was initiated. Thus, with the airplane then being stable, there is no major effect of rate of corrective control in terms of overshoot. In the present flight investigation the approach to the pitch-up was made slowly so that the measured data could be considered

to have been taken under static conditions. Consequently, the rates used in the calculations were necessarily chosen small to match those used in flight. The delay time used was close to that actually used in flight when, for familiarization and pilot opinion flights, the pilot was instructed to recover as soon as the pitch-up started. Thus the corrective control was initiated much sooner than in reference 7.

Effect of change in speed.— The change in control effectiveness with change in Mach number can affect the pitch-up encountered in flight where it is normal for the speed to decrease rapidly as the airplane pitches up to high normal accelerations. In the region of the most severe pitch-up it is usual for the control effectiveness to increase with a decrease in Mach number. To enter the pitch-up region in the first place considerable elevator deflection is required, producing a down load on the tail. As the speed drops off and the elevator effectiveness increases an additional down load is provided by the elevator deflection, increasing the already unbalanced nose-up pitching moment of the airplane.

This factor was not taken into account in the calculations because the simplified calculation procedure used did not take account of changes in speed. However, it can be seen from figure 2, assuming a drop in Mach number from 0.90 to 0.85, that the airplane of reference 1 would have a 40-percent increase in tail load due to the change in control effectiveness, while the airplane of the present tests would have only a 22-percent increase. Thus, it is evident that the difference in change in control effectiveness with change in Mach number is an additional factor which tends to make the pitch-up of the airplane of reference 1 more severe than that of the airplane of the present tests.

No attempt was made to compare measured and computed responses of the airplane directly by using actual control inputs from flight records in the computations. The simplified calculation procedure used did not take account of the changes in speed and in control effectiveness. Since the pitch-up was primarily due to a premature stall of the wing tips, it was felt that the aerodynamic parameters involved in the computation would change significantly from their low angle-of-attack values. To attempt to determine their values in the pitch-up region was beyond the scope of this investigation.

CONCLUSIONS

The investigation of the longitudinal stability and buffet characteristics of a 35° swept-wing fighter airplane with two different tail heights has indicated that:

1. There is very little effect of changing the tail height from 0.202 $b/2$ to 0.081 $b/2$ above the wing-chord plane on the stability characteristics of the test airplane.
2. There is no noticeable increase in buffeting at the center of gravity of the airplane as the tail enters the wake of the wing.
3. The test airplane, while having essentially the same unstable airplane static pitching moments as another version of this airplane with an uncontrollable pitch-up, had only a mild pitch-up which was easily controllable. An analysis shows that this improvement for the present test airplane could be attributed largely to an increased control effectiveness, an increased moment of inertia, and a decrease in the change in control effectiveness with change in Mach number.

Ames Aeronautical Laboratory
National Advisory Committee for Aeronautics
Moffett Field, Calif., June 21, 1954

REFERENCES

1. Anderson, Seth B., and Bray, Richard S.: A Flight Evaluation of the Longitudinal Stability Characteristics Associated With the Pitch-Up of a Swept-Wing Airplane in Maneuvering Flight at Transonic Speeds. NACA RM A51112, 1951.
2. Rolls, L. Stewart, and Matteson, Frederick H.: Wing Load Distribution on a Swept-Wing Airplane in Flight at Mach Numbers Up to 1.11, and Comparison With Theory. NACA RM A52A31, 1952.
3. Weil, Joseph, and Gray, W. H.: Recent Design Studies Directed Toward Elimination of Pitch-Up. NACA RM L53I23c, 1953.
4. Morrison, William D., Jr., and Alford, William J., Jr.: Effects of Horizontal-Tail Height and a Wing Leading-Edge Modification Consisting of a Full-Span Flap and a Partial-Span Chord-Extension on the Aerodynamic Characteristics in Pitch at High Subsonic Speeds of a Model with a 45° Sweptback Wing. NACA RM L53E06, 1953.
5. Alford, William J., Jr., and Pasteur, Thomas B., Jr.: The Effects of Changes in Aspect Ratio and Tail Height on the Longitudinal Stability Characteristics at High Subsonic Speeds of a Model With a Wing Having 32.6° Sweepback. NACA RM L53L09, 1954.
6. Bandettini, Angelo, and Selan, Ralph: The Effects of Horizontal-Tail Height and of a Partial-Span Leading-Edge Extension on the

Static Longitudinal Stability of a Wing-Fuselage-Tail Combination Having a Sweptback Wing. NACA RM A53J07, 1953.

7. Campbell, George S., and Weil, Joseph: The Interpretation of Non-linear Pitching Moments in Relation to the Pitch-Up Problem. NACA RM L53I02, 1953.
8. Triplett, William C., and Smith, G. Allan: Longitudinal Frequency-Response Characteristics of a 35° Swept-Wing Airplane as Determined From Flight Measurements, Including a Method for the Evaluation of Transfer Functions. NACA RM A51G27, 1951.
9. McFadden, Norman M., Rathert, George A., Jr., and Bray, Richard S.: The Effectiveness of Wing Vortex Generators in Improving the Maneuvering Characteristics of a Swept-Wing Airplane at Transonic Speeds. NACA RM A51J18, 1952.

TABLE I.— DIMENSIONS OF THE TEST AIRPLANE

Wing	
Area, sq ft	287.90
Span, ft	37.12
Aspect ratio	4.785
Taper ratio	0.5131
Dihedral angle, deg	3.00
Mean aerodynamic chord, in.	97.03
Sweepback of 25-percent element, deg	35.2
Incidence of root chord, deg	1
Geometric twist, deg	2
Root airfoil (Mod) NACA 0012-64 (perpendicular c/4, 9.88-	
percent thickness parallel to air stream)	
Tip airfoil (Mod) NACA 0012-64 (perpendicular c/4, 8.55-	
percent thickness parallel to air stream)	
Ailerons (Straight-sided type, irreversible boost and artificial feel)	
Area, each, sq ft	16.36
Leading-edge slats	
Area (one side only), sq ft	17.72
Span, in.	155.24
Chord, in.	16.43
Horizontal tail	
Area (total), sq ft	53.9
Area (movable), sq ft	39.01
Span, ft	16.85
Aspect ratio	5.102
Taper ratio	0.4232
Mean aerodynamic chord, in.	41.60
Sweepback of 25-percent element, deg	35.00
Tail length, ft	15.7
Airfoil section	NACA 64A010
Irreversible boost and artificial feel	
Vertical tail	
Area (excluding dorsal fin), sq ft	31.05
Aspect ratio	1.71
Taper ratio	0.369
Mean aerodynamic chord, in.	55.08
Sweepback of 25-percent element, deg	35.00
Fuselage	
Side area, sq ft	196.69
Length (basic), in.	468.00
Fineness ratio	7.035
Surface area, total, sq ft	1209.84
Frontal area, total, sq ft	61.93
Gross weight (average at test altitude), lb	14500

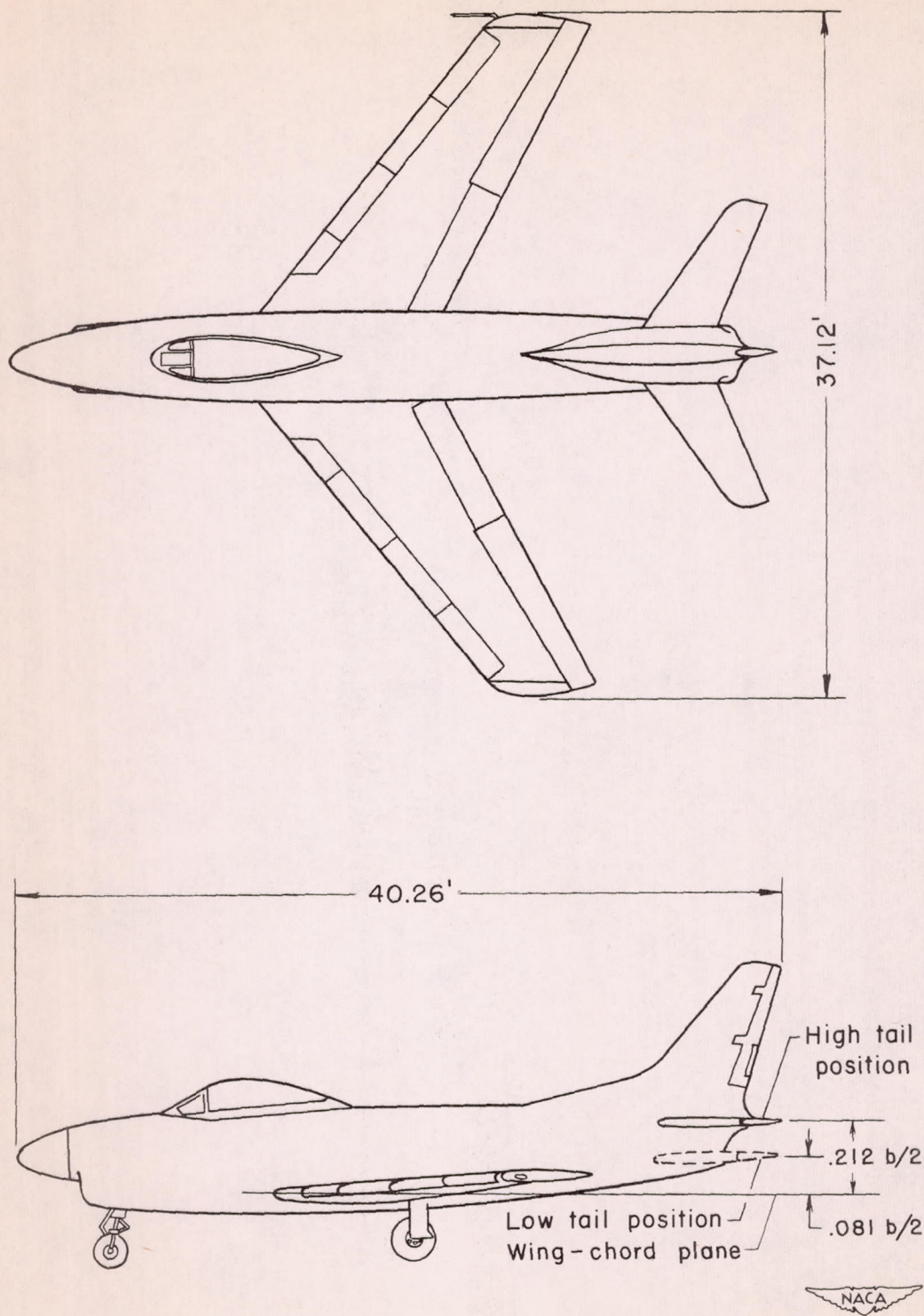

(a) Two-view drawing.

Figure 1.- Test airplane.

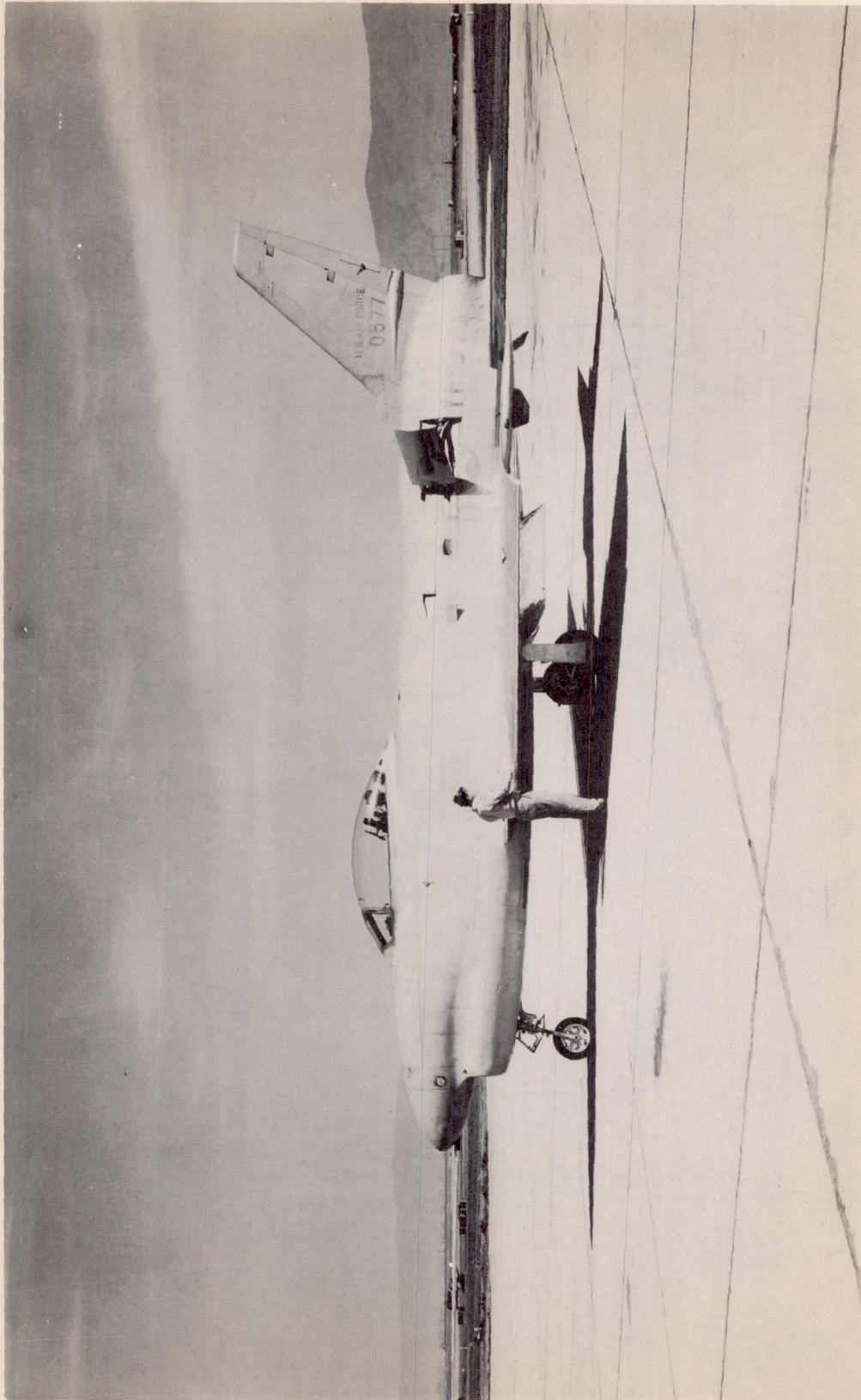

A-17996

(b) Low-tail installation.

Figure 1.- Continued.



A-18247

(c) High-tail installation.

Figure 1.- Concluded.

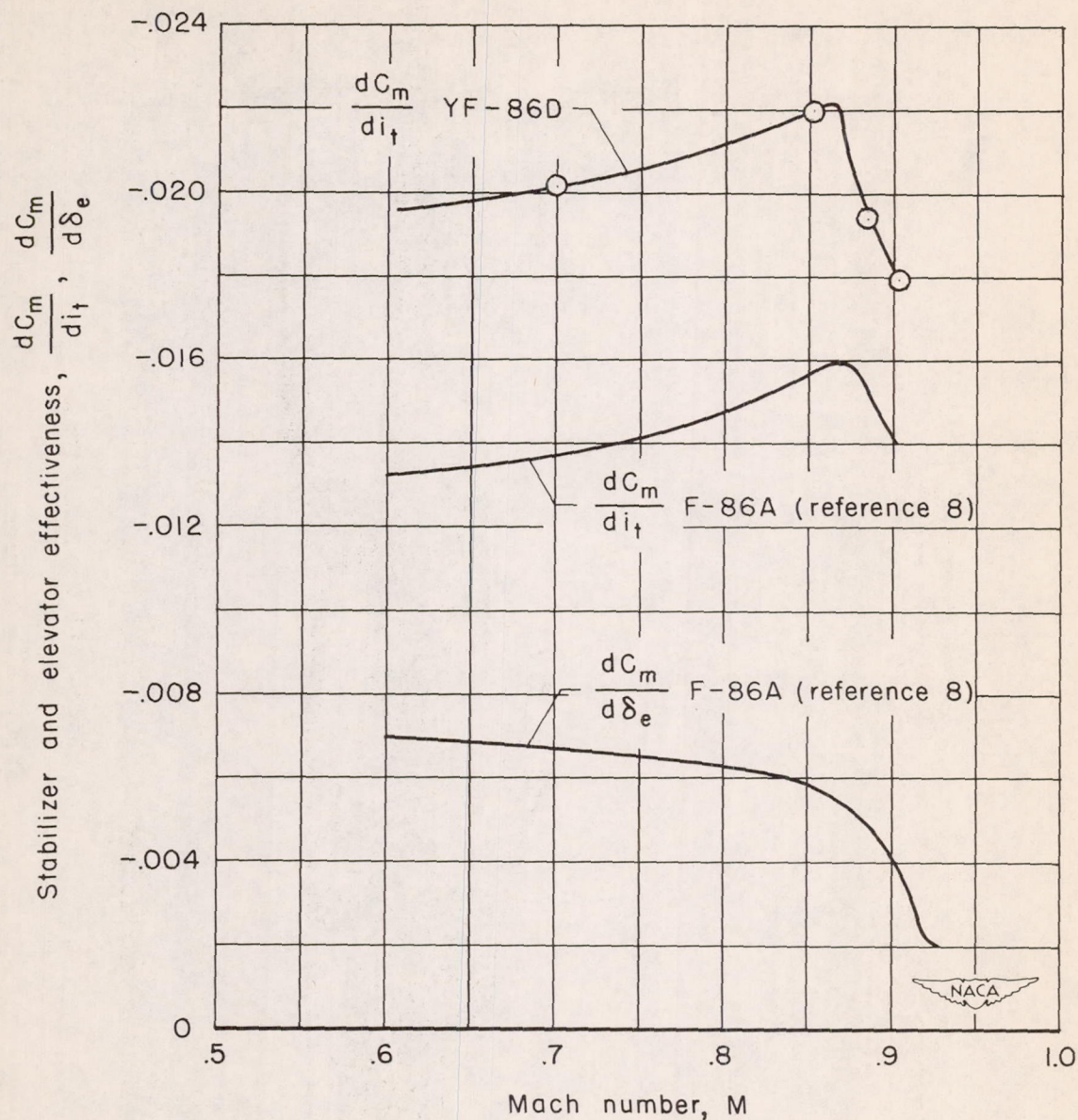

Figure 2.- Stabilizer and elevator effectiveness.

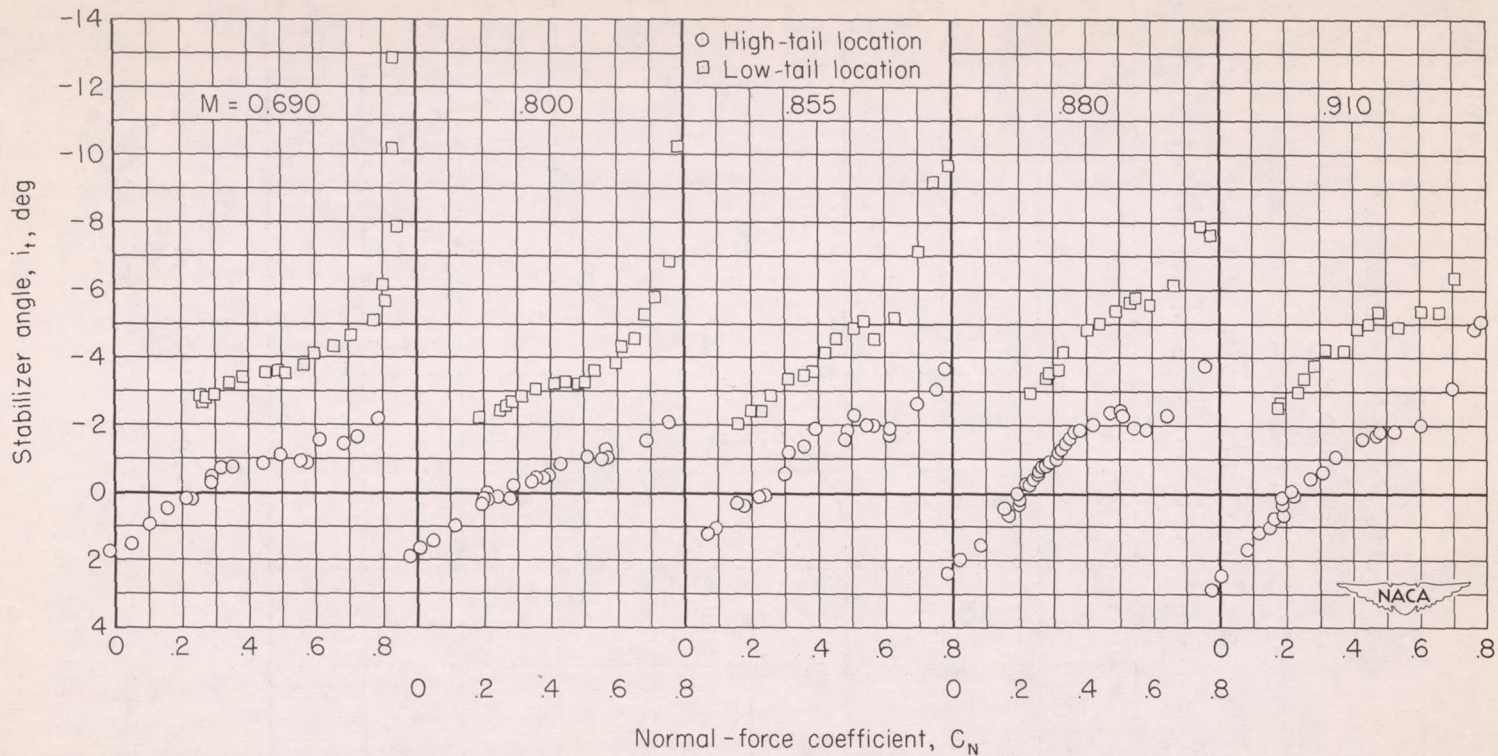

Figure 3.- Stabilizer angle required to balance airplane for both high- and low-tail installations.

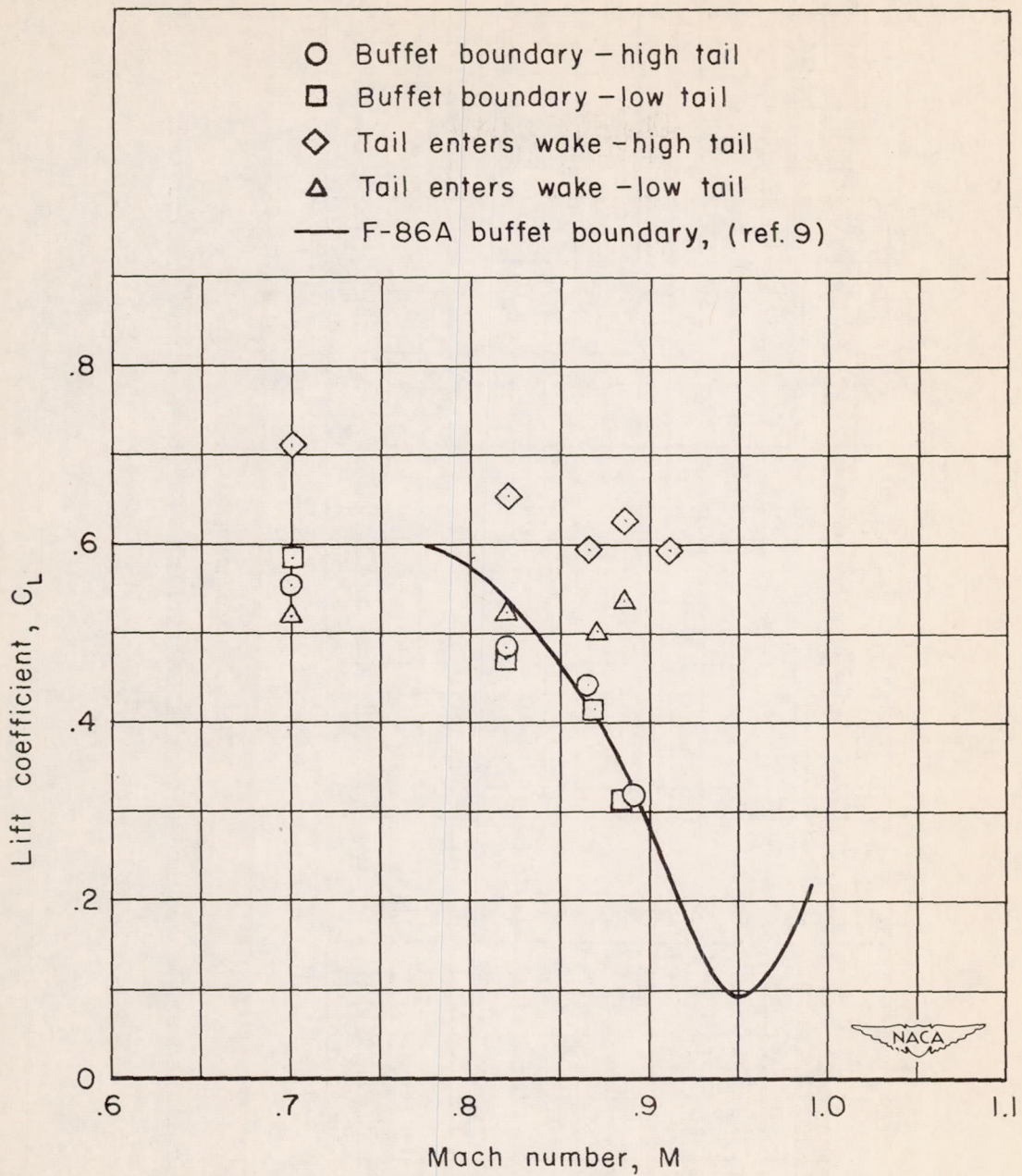

Figure 4.- Buffet boundary of test airplane.

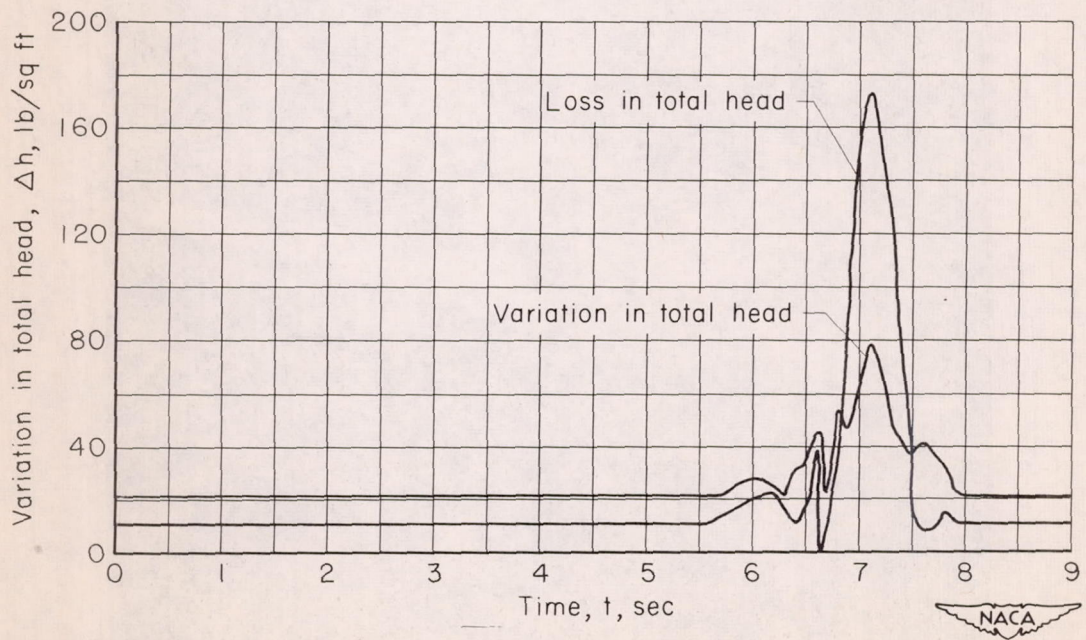
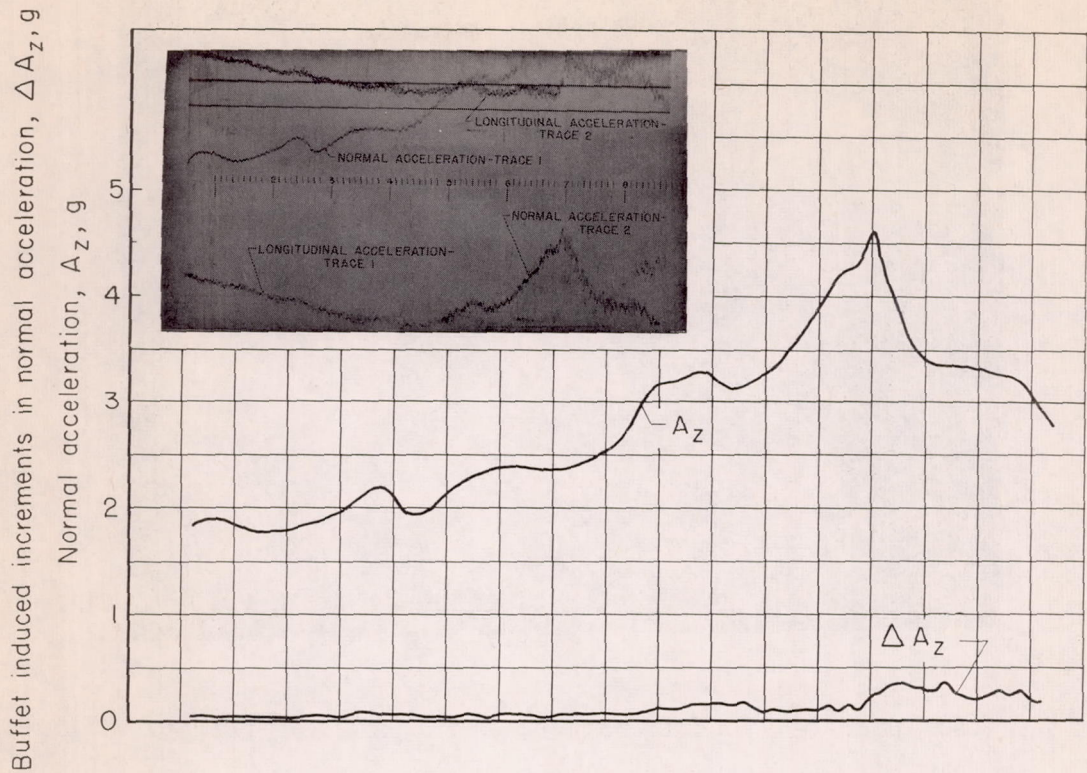
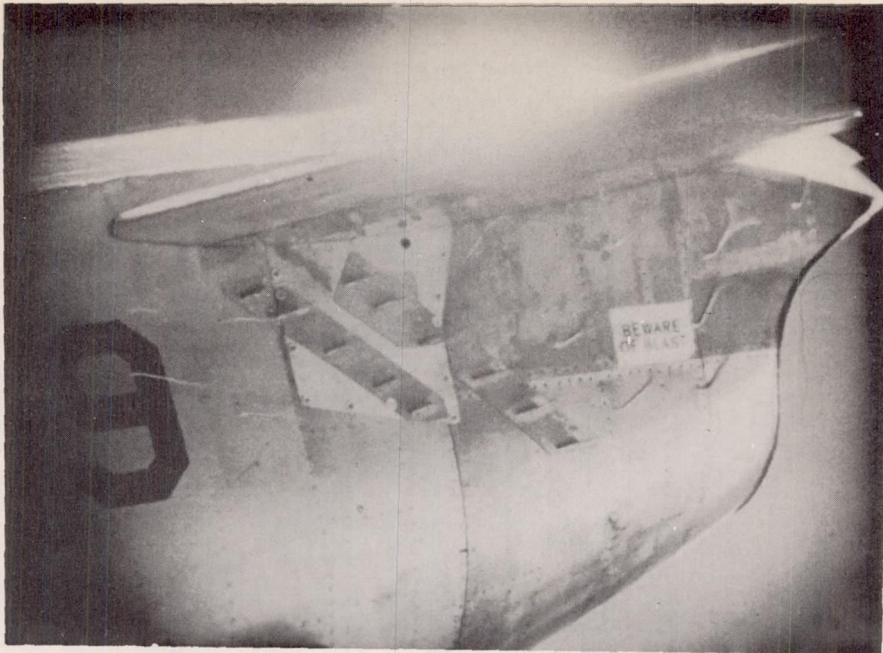

Figure 5.- Time history of normal acceleration and total head at tail during pitch-up; $M = 0.92$.



A-19332

(a) High-tail configuration; $M = 0.905$, 1 g flight.



A-19210

(b) Low-tail configuration; $M = 0.94$, $1/2$ g flight.

Figure 6.- Tuft study of flow in vicinity of tail.

CONFIDENTIAL

CONFIDENTIAL

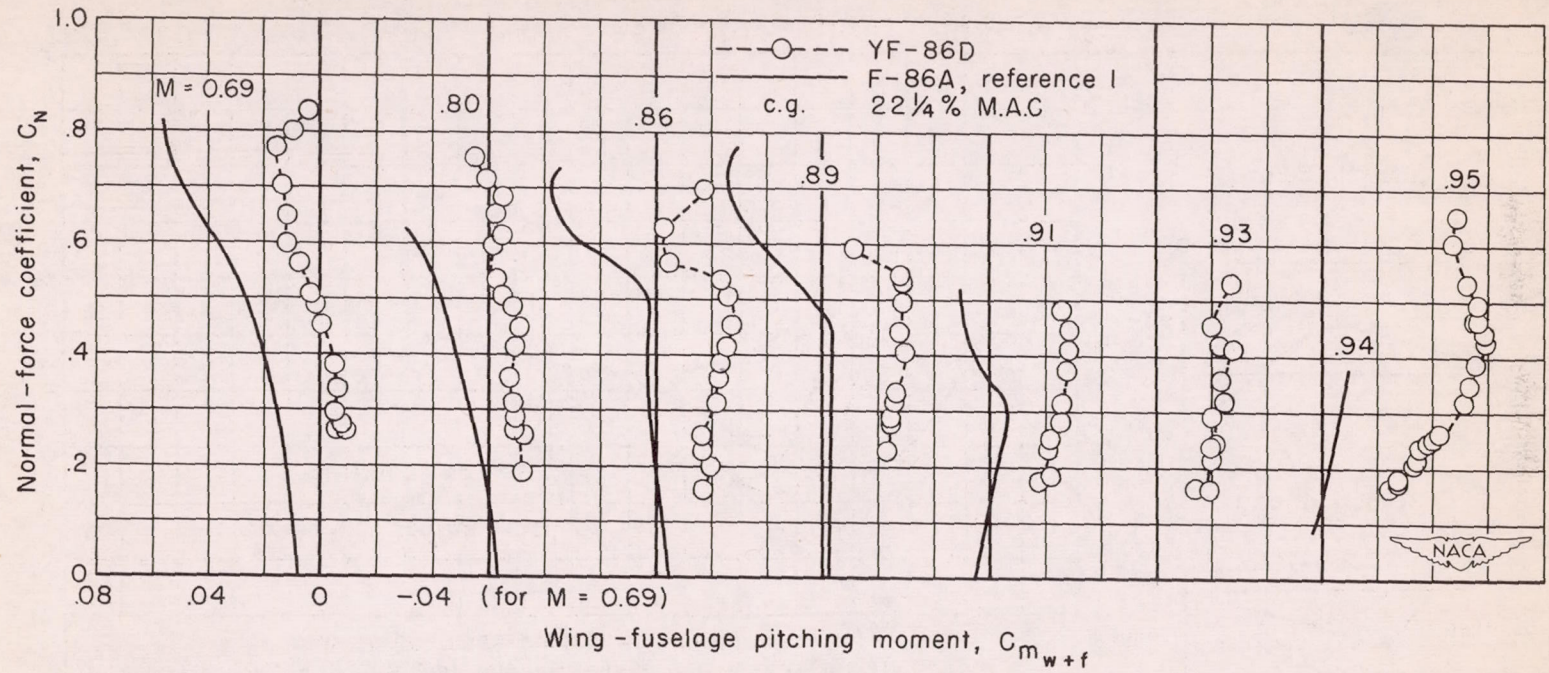

Figure 7.- Wing-fuselage pitching moments.

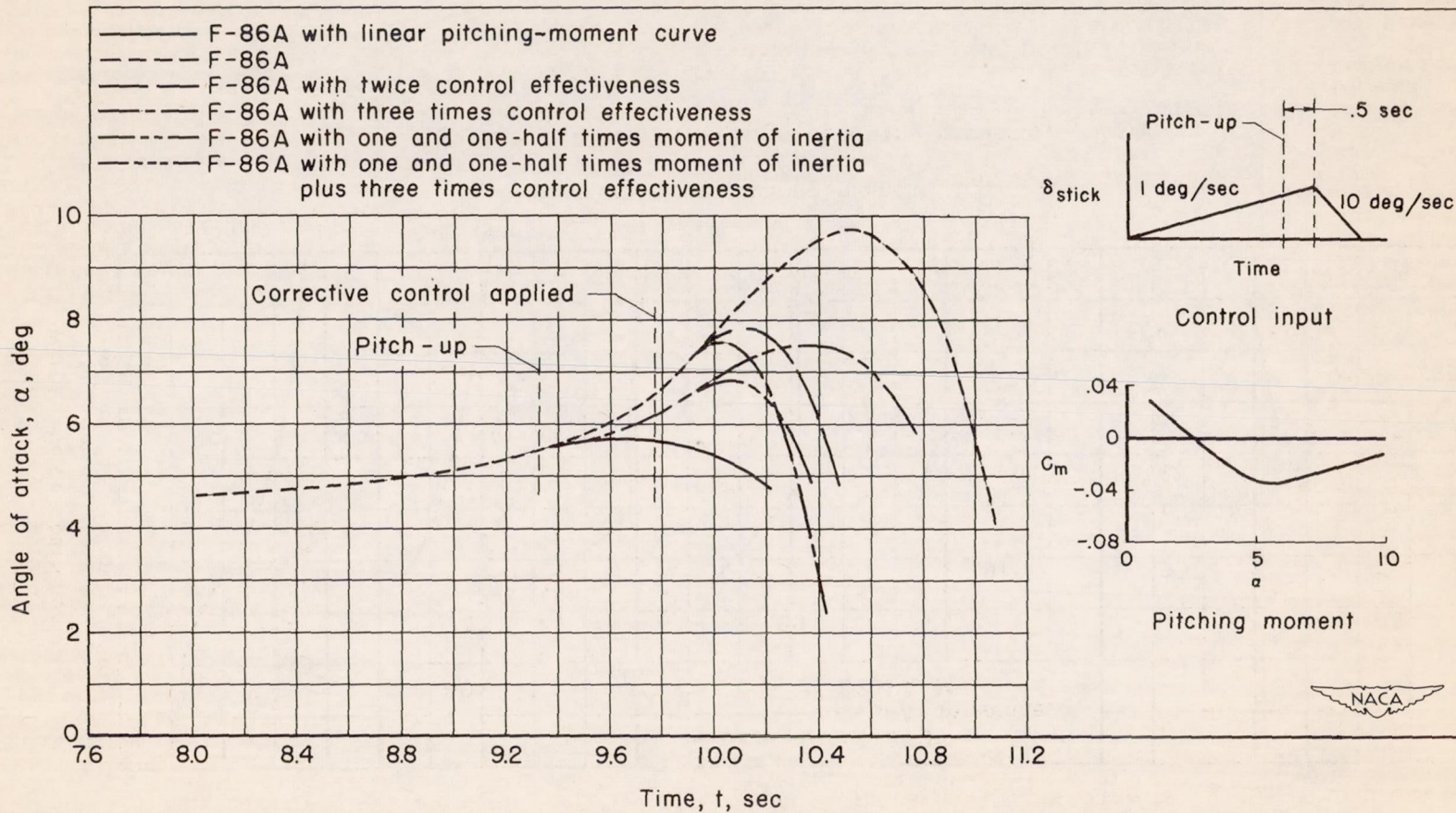

Figure 8.- Calculated time histories of the pitch-up.

CONFIDENTIAL

NACA-Tangley - 1-18-55 - 350

CONFIDENTIAL

NACA RM A54FF21

CONFIDENTIAL

CONFIDENTIAL