

RESEARCH MEMORANDUM

PERFORMANCE OF SLURRIES OF 50 PERCENT BORON IN JP-4 FUEL
IN 5-INCH RAM-JET BURNER

By Thaine W. Reynolds and Donald P. Haas

Lewis Flight Propulsion Laboratory
Cleveland, Ohio

NATIONAL ADVISORY COMMITTEE
FOR AERONAUTICS

WASHINGTON

June 10, 1954

Declassified June 20, 1957

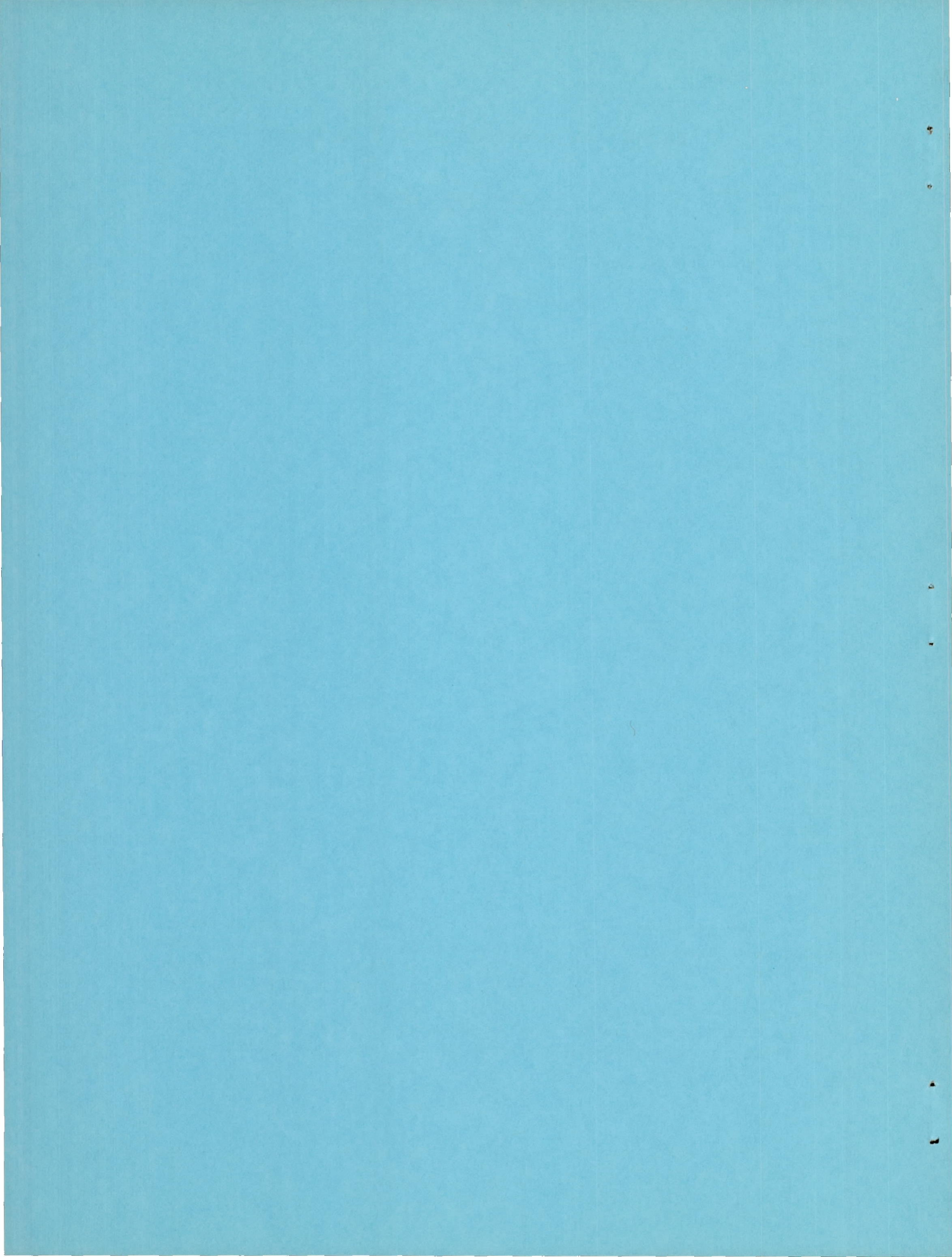

NATIONAL ADVISORY COMMITTEE FOR AERONAUTICS

RESEARCH MEMORANDUMPERFORMANCE OF SLURRIES OF 50 PERCENT BORON IN JP-4 FUEL
IN 5-INCH RAM-JET BURNER

By Thaine W. Reynolds and Donald P. Haas

SUMMARY

The performance of slurries of 50 percent boron in MIL-F-5624A grade JP-4 fuel was evaluated in a 5-inch ram-jet burner. Because the reactivity of the slurry fuel apparently was below that of JP-4 fuel alone, the limited sheltered region behind a V-gutter flame holder proved inadequate for piloting the flame. Can-type flame holders were therefore used throughout the investigation.

Boron slurries gave higher heat outputs than did the JP-4 fuel only at fuel-air ratios above stoichiometric for JP-4 fuel. In order to realize the potential range extension of ram-jet-powered aircraft through use of boron slurry fuels which have high heat content per unit weight and volume, it will be necessary to efficiently burn the boron slurries at the low fuel-air ratios necessary to achieve high propulsive efficiency. The combustion efficiencies of the boron slurries must therefore be improved considerably in the lean region.

Highest heat outputs were obtained when some means of aiding the influx of boron to an intense piloting region was added to the flame holder. High wall temperatures were an aid to lean-region combustion smoothness but had little influence on the heat outputs obtained. An increase in burner length from 40 to 52 inches also had little effect on the heat output over the narrow range of fuel-air ratios where comparison data were obtained.

Performance data are presented in terms of heat output per pound of combustion mixture for several flame-holder configurations. Combustion efficiency values are presented for the configuration which seemed most satisfactory in the 5-inch burner. The combustion efficiency for the 50-percent-boron slurry in the best burner configuration was 89 percent at an equivalence ratio of unity, assuming the chemical equilibrium to be frozen by the water-quench spray at the combustor outlet.

INTRODUCTION

The application of the ram-jet engine to propulsion of long-range supersonic missiles offers an opportunity to use the unique characteristics of high-energy fuels. Boron as a fuel is capable of increasing the range of a missile by 40 percent or more over that obtained using hydrocarbon fuels (ref. 1). The practical problems involved in handling, flowing, and metering the material as a dry solid or in the form of powder are great enough to warrant investigating the possibilities of using the fuel in the form of a slurry with a hydrocarbon fuel, even though the heating value, density, and, hence, fuel performance capabilities are lower than those for the solid fuel alone.

Analyses indicating the potential increased performance of high-energy fuels are based on the thermodynamic properties alone. The ultimate usefulness of a particular fuel will, however, depend upon reactivity, handling characteristics, stability, and possibly other factors. For the flight path assumed in the analysis of reference 1, for example, the range is directly proportional to the effective heating value of the fuel; hence, it is imperative that the fuel be burned efficiently if the full potentialities of the fuel are to be realized.

Experimental work done in a 2-inch burner (ref. 2) indicated that combustion efficiencies of the order obtained with hydrocarbon fuels could be obtained with 30-percent slurries of boron in hydrocarbon fuel, thus offering an advantage in heat output for the boron slurries. Because this previous evaluation was obtained in a small burner, it was attempted to extend the heat-output and combustion-efficiency data for boron slurries to larger more typical combustor configurations operating at somewhat more realistic conditions. Some improvements in the state of the slurry-mixing art allowed the use of slurries of higher boron concentration than used in the preceding cited investigation.

This report is concerned with the combustion of slurries of 50 percent boron in JP-4 fuel in a 5-inch ram-jet burner. Heat-output data for several can-type flame holders with slurry fuel and with JP-4 fuel alone are presented. Combustion efficiencies for the most effective flame-holder configuration tested are also included.

APPARATUS AND PROCEDURE

Test installation. - The schematic diagram of the ram-jet burner (fig. 1) shows the general arrangement of the piping and the location of the instrumentation used in this investigation. The basic burner was the same as that used in reference 3; modifications to the burner length and the fuel injector constituted the major changes. Electrically preheated and metered air at 40 pounds per square inch gage was supplied to

the plenum chamber, which contained the air-control unit. Air flow was controlled by a movable sleeve blocking a variable number of the orifices in two perforated plates through which air flowed to the diffuser inlet. Choked flow was maintained at the control unit isolating burner pulsations. A variable-area calibrated orifice located upstream of the control unit (not shown in fig. 1) metered the air mass flow.

Fuel was injected near the inlet of the diffuser section approximately 7 feet upstream of the flame holder. An air-atomizing concentric fuel injector was used throughout the investigation for both the slurry and hydrocarbon fuels (fig. 2).

A hydrogen-oxygen pilot flame in the dome of the flame holder ignited the fuel-air mixtures entering the combustion chamber. The amount of heat in the pilot was always less than 1 percent of the total heat in the main fuel. Because the presence of the pilot flame had no effect on the measured heat output with the hydrocarbon fuels, it was usually maintained during the course of a run except when determining stability limits. With slurry fuels, however, the pilot flame was present during all runs except one with uncooled firebrick burner walls.

A variable-area nozzle at the outlet of the burner was used to regulate the burner-inlet pressure. The nozzle could be adjusted continuously during the course of a hydrocarbon fuel run, but invariably would seize early in the course of a slurry run when solids were deposited on the nozzle vanes and walls making further adjustment impossible. An initial burner pressure of 1 atmosphere was set at the start of each run and maintained as long as the nozzle remained free.

Water metered into the exhaust-gas stream immediately downstream of the exhaust nozzle quenched the reaction and cooled the exhaust gas to about 600° F. The gas temperature was then measured at a thermocouple station located approximately 15 feet downstream of the water-spray bars.

Other temperature and pressure sensing stations were located at the variable-area air-flow orifice, diffuser inlet, and burner inlet. Means of measuring jacket-coolant flow rates and temperatures were also provided.

Fuel system. - Slurry and JP-4 fuels were handled in the fuel system shown in figure 2. The main fuel tanks were located outside the test cell and could be pressurized with nitrogen to 100 pounds per square inch gage. Flow from the JP-4 fuel tanks was metered with a calibrated rotameter and controlled by a remotely operated throttle. The JP-4 fuel could be switched either to the fuel injector or to the special slurry fuel tank where it served as a pumping fluid. The slurry tank consisted essentially of a cylinder and movable piston which separated the slurry from the pumping fluid. A tubular tail rod prevented the piston from

cocking in the cylinder and also provided an air bleed for the volume in the cylinder below the piston where the slurry was placed. A cover plate through which the tail rod protruded was flange-bolted to the top of the cylinder, and necessary packing was used to obtain a leak-proof chamber above the piston into which the JP-4 fuel from the main line could be diverted. The pressurized JP-4 fuel flowing into the slurry tank displaced the piston, forcing the slurry to flow to the fuel injector. Slurry mass flow was controlled by the throttle in the JP-4 fuel line and was determined by applying the appropriate density correction to the JP-4 fuel flow obtained at the rotameter. Complete removal of air pockets from the fuel system insured positive displacement of the slurry by the JP-4 fuel.

Flame-holder and burner configurations. - The can flame-holder configurations used during the course of the investigation are shown in figure 3. The letter identifies the approximate can size as to length and dome diameter, and the number signifies changes in the hole configuration or the addition of scoops or dome perforations to the basic can. The description and the major dimensions of the various flame holders are given in table I. Flame holder B-2, found to be the most effective flame holder tried for the slurry fuel, was initially developed as a piloting flame holder for a large engine (ref. 4) and is dimensioned in detail in figure 4. The B configuration blocked 41 percent of the duct at the can dome, had a 40-percent open periphery at the first row of holes, and had 122-percent open-hole area with the hole sizes increasing downstream to afford a parabolic mixture-entry pattern. All other configurations had similar parabolic entry patterns except flame holder C-3, the slotted aft section of that can having essentially a linear mixture entry pattern. The flame holders were fabricated of 1/32-inch-thick Inconel.

The initial burner length used at the start of the work was 40 inches, measured from the dome of the flame holder to the center line of the water-quench-spray bars. An uncooled section 12 inches long was added at the upstream end of the burner to determine the effect of an increase in burner length. The water-cooled burner housing was replaced with a section having a 2-inch lining of firebrick to obtain high burner-wall temperatures for one run. All burner components were readily removable to allow changes in configuration and to facilitate the necessary removal of deposits after each run.

Fuels. - The boron powder used throughout the flame-holder development phase of the investigation exhibited the following analysis range:

Soluble boron, percent	0 - 0.4
Moisture, percent	0.1 - 0.8
Total boron, wet, percent	87 - 91.3
Total boron, dry, percent	87.5 - 91.5
Free boron, percent	87.3 - 91.4
Average particle size, μ	1

This material had an average free boron content of 90.0 percent. The slurry composition in percent by weight of components was as follows:

Boron powder, percent	50
JP-4 Fuel, percent	48
Wetting agent (glycerol sorbitan laurate), percent	1.6
Gelling agent (aluminum octoate), percent	0.4

The 90-percent-pure-boron slurry had a density of 1.15 grams per cubic centimeter and a lower heating value of 20,765 Btu per pound. The lower heating value of the JP-4 fuel was taken as 18,675 Btu per pound. The stoichiometric fuel-air ratios for the 90-percent-pure-boron slurry and the JP-4 fuel were taken as 0.0858 and 0.068, respectively.

For comparison purposes, a slurry was made with boron powder containing 86.5 percent total boron and 12.5 percent magnesium as supplied by the manufacturer. The lower heating value of this slurry, with all metal assumed free, was 20,908 Btu per pound; and the stoichiometric fuel-air ratio was 0.0862.

The hydrocarbon fuel used throughout this investigation was MIL-F-5624A grade JP-4.

CALCULATIONS

The comparisons of fuels and flame-holder configurations were made on the basis of heat output per pound of combustion mixture, because air specific impulse depends on this quantity. The relation between heat output and specific impulse for multiphase systems is not sufficiently developed to allow accurate conversion to terms of specific impulse of the boron slurry data for the range of fuel-air ratios reported or at the low efficiencies encountered.

The following equation defines the experimentally measured heat output:

$$\Delta H_o = \Delta H_w + \Delta H_e + \Delta H_j$$

where

ΔH_o enthalpy rise (heat output), Btu/lb mixture

ΔH_w enthalpy rise of quench water, Btu/lb combustion mixture

ΔH_e enthalpy rise of combustion mixture, Btu/lb mixture

ΔH_j enthalpy rise of jacket coolant, Btu/lb mixture

For mixtures richer than stoichiometric,

$$\Delta H_e = \Delta H_s + \left[\frac{1}{1 + (f/a)_e} \right] \left[(f/a)_e - (f/a)_s \right] \left[(L_v)T_i + c_p(T_e - T_i) \right]$$

where

ΔH_s enthalpy rise of stoichiometric combustion mixtures,
Btu/lb actual mixture

$(f/a)_e$ actual weight fuel-air ratio

$(f/a)_s$ stoichiometric fuel-air ratio

L_v latent heat of vaporization, Btu/lb fuel

T_i inlet temperature, $^{\circ}R$

c_p mean specific heat of fuel, Btu/ $(^{\circ}F)(lb \text{ fuel})$

T_e exhaust-gas temperature, $^{\circ}R$

The lower heating value of the fuels used could not be attained in the 5-inch burner when it was operated at near-stoichiometric fuel-air ratios. The water spray immediately downstream of the exhaust nozzle cooled the combustion products very rapidly to temperatures near $600^{\circ} F$, probably freezing the composition of the exhaust products at a high-temperature equilibrium level. The dissociation enthalpy, therefore, was not recovered as measureable sensible enthalpy as the products cooled.

The dissociation enthalpy, which is lost through freezing the equilibrium of the combustion products at the flame-temperature composition and cooling these products to $600^{\circ} F$, is shown for JP-4 fuel and boron slurry in figure 5. The dissociation enthalpy is expressed as a fraction of the lower heating value of the fuels. Sufficient information was available to permit an adequate determination of the dissociation enthalpy curve for the JP-4 fuel (refs. 5 and 6), but equilibrium data for the boron slurry are limited; therefore, the curve presented for the slurry fuel is approximate and is based on values of equivalence ratio of 0.7 and 1.0.

Experimentally obtained heat outputs for hydrocarbon fuels, presented in RESULTS AND DISCUSSION, substantiate the supposition that the equilibrium is frozen. It was therefore assumed that a major portion of the loss in heat output was due to frozen equilibrium when rich mixtures burned efficiently; so curves of maximum heat output based on this assumption are included for comparison with the experimental data.

The combustion-efficiency values presented are based on the expression

$$\eta = \frac{(1 + f/a)\Delta H_o}{(f/a)\Delta H_c}$$

where

ΔH_c lower heating value of fuel, Btu/lb fuel

This expression was used because most of the data was obtained in the rich region where dissociation equilibrium data were inadequate for determining the frozen equilibrium loss. For comparison purposes in the region up to stoichiometric ratios, efficiencies were calculated by substituting $\Delta H_c(1 - x)$ for ΔH_c in the preceding expression for efficiency, where x is the dissociation enthalpy fraction of the lower heating value as determined from figure 5.

RESULTS AND DISCUSSION

In order to evaluate the combustion performance of the boron slurry properly, it was necessary to develop a flame holder which possessed the features necessary for stable and efficient combustion over a reasonable operational range. The initial work, therefore, was essentially an attempt to develop adequate burner designs for boron slurries.

Concurrent work in a smaller burner had indicated the reactivity of a boron slurry to be comparable with that of JP-4 fuel alone (ref. 7): therefore, several attempts were made to burn the slurry fuel by using a V-gutter flame holder at the onset of the investigation. Sluggish starting, excessive flash back, and rough burning coupled with inferior heat outputs for slurry fuels as compared with hydrocarbon fuels alone indicated that the sheltered zone behind the gutter was insufficient for adequate piloting of the slurry fuel. After the V-gutters were found unsatisfactory, the investigation was directed to can-type flame holders.

The initial investigation of boron slurry combustion in can-type flame holders explored the effects of pilot-zone volume and inlet mixture velocity on combustion performance (fig. 6). Stable combustion was obtained with flame holder A at inlet velocities of 186 to 188 feet per second but only at high fuel-air ratios. In an attempt to improve the lean stability limit, flame holder B-1, with a larger piloting zone, was employed and the inlet velocity was reduced to give an increased mixture residence time in the piloting region. A reduction in the inlet velocity to 145 feet per second allowed operation at fuel-air ratios below stoichiometric; therefore, for all subsequent runs, initial velocities were

set near 140 feet per second in an attempt to discern improvement in performance independent of velocity effects. Upon seizing of the exhaust nozzle, however, the velocity at the burner inlet could no longer be maintained constant; at lean fuel-air ratios, the burner-inlet pressure decreased and the inlet velocity increased.

The determination of reproducible stability limits for the boron slurry fuel was not attempted because of the limited fuel quantity which could be handled in each run and the difficulty of reigniting the burner due to damage or destruction of burner components by rough combustion. The operational limits shown on the figures therefore signify that burning was either interrupted by component failure or conditions were restricted by the operator to prevent component failure.

The improvements in stability and heat output with larger piloting volume and lower inlet velocities along with the data reported in reference 2 on boron slurry combustion in a 2-inch burner, indicating improved performance at rich fuel-air ratios, suggested the use of auxiliary means for introducing a greater amount of boron powder into the piloting region. Flame holder B-2 utilized scoops on the first row of holes in obtaining a boron influx. Figure 7 shows the performance gain by the use of scoops mainly in an extension of the lean operational limit to a fuel-air ratio of 0.062; however, burning became rough and heat output fell off to values below those obtainable with hydrocarbon fuel at fuel-air ratios below about 0.0775. A JP-4 fuel check point was included on this figure and showed the experimental heat output to be near the calculated maximum for that fuel.

High-pressure-drop flame holders having large pilot volumes were also tested for piloting effectiveness. The operating range and the heat output of flame holder C-1 with slurry fuel were improved when the dome was perforated (flame holder C-2) to allow the flow of impinging boron into the piloting region (fig. 8).

Flame holder C-3, with a cold-flow pressure drop Δp of 8.9 times the dynamic head at the burner inlet q , is compared with flame holder C-2 ($\Delta p/q = 12.2$) in figure 9. Flame holder C-3, having longitudinal slots rather than circular holes for mixture admission in the downstream portion of the can, did not perform as well as flame holder C-2.

An increase in combustor length from 40 to 52 inches with the use of flame holder B-2 indicated little if any increase in heat output over the small range of comparable fuel-air ratios, as shown in figure 10. The heat outputs for JP-4 fuel as shown by two check points are essentially the same for the 40- and 52-inch burners. Subsequent runs excluding one with a ceramic-lined combustor were made in the 52-inch-long burner.

High wall temperature obtained by lining a 40-inch burner with firebrick aided combustion smoothness in the lean region and allowed stable burning at fuel-air ratios of 0.061 without the use of the auxiliary pilot flame, the only case where the pilot was found unnecessary to maintain combustion. In the fuel-air-ratio regions near and above stoichiometric where smooth burning was obtained for both the 40-inch ceramic-lined and the 52-inch cooled burners with the same flame holder (B-3), the heat outputs for the ceramic combustor were slightly lower with both JP-4 and slurry fuels (fig. 11).

Flame holder B-3, used in the preceding test, was found to be the most effective for use with JP-4 fuel and therefore showed the close similarity of the experimental heat output obtained in the 52-inch cooled burner with the calculated maximum heat-output curve based on frozen equilibrium, thus substantiating the assumption of frozen equilibrium in this burner.

Performance of a slurry made with boron powder containing 12.5 percent magnesium and 86.5 percent boron was compared with that obtained using the 90 percent pure powder (fig. 12). It was thought that the presence of the highly reactive magnesium would favorably affect the performance of the slurry fuel. Analysis showed the magnesium was not free metal in this material, however, and no recognizable difference in burning characteristics or heat output was observed.

A summary curve of the combustion efficiencies for all the data taken with flame holder B-2 in 40- and 52-inch-long burners with 90 percent pure boron is presented in figure 13. Highest efficiencies with the boron slurry were obtained at an equivalence ratio of 1; the maximum combustion efficiency based on the lower heating value of the fuel was about 80 percent compared with a maximum of 89 percent when the efficiency was based on the effective heating value obtained by deducting the dissociation enthalpy from the lower heating value of the fuel. The difficulties in ignition and combustion of boron slurries in the lean region where combustion temperatures are low are reflected by the low combustion efficiencies obtained. Other investigators (ref. 8) have obtained similar results with 40-percent slurries, reporting most efficient burning in the range of equivalence ratios from 1.0 to 1.3. Values of combustion efficiency calculated from the specific-impulse values reported in reference 8 showed a peak combustion efficiency of about 72 percent at an equivalence ratio of 1.1; this value checks well with the combustion efficiency at that equivalence ratio shown in figure 13. All data presented in the curves are tabulated in table II.

Flame-holder life. - The high combustion temperatures obtained with slurry fuels rendered the flame holders more susceptible to failure during rough burning than was the case with hydrocarbon fuels. The flame holders seemed incapable of withstanding more than a minute of rough

combustion and in some cases failed at the start of a run before smooth burning could be established. Certain flame-holder configurations exhibited peculiar modes of failure, as shown in figure 14. These were probably caused by direct flame impingement and perhaps by the fluxing action of the boron oxide.

Combustor deposits. - At various times, samples of deposits accumulated on burner components, as shown in figure 15, were analyzed for boron oxide content; the highest oxide content indicated about 70 percent of the boron burned. Such accumulations, however, do not necessarily represent a true sample of the solids entrained in the stream. The solid deposits encountered, beside jamming the exhaust nozzle, plugged the equipment prepared for an attempt to sample the exhaust stream.

Slurry flow characteristics. - Considerable difficulty was encountered with the unpredictable flow properties of the boron slurries, which were prepared in essentially the same manner from the same formula. On some occasions, slurries that appeared normal would not flow at a sufficient rate through the fuel system. The physical properties seemed very sensitive to differences in batches of boron powder and wetting or gelling agents, which suggests that component purity control is a large part of the flow problem.

CONCLUDING REMARKS

Boron slurry fuel is not an easy fuel to handle, control, or burn. The reactivity of the boron slurry fuel tested seemed lower than that for the JP-4 fuel alone. The use of can-type flame holders affording large sheltered piloting regions was necessary to obtain even fair combustion efficiencies with the slurry fuel. The high heat output for the boron slurry coupled with better burning in the rich region indicates that further work with slurry combustion in divided-flow combustors might indicate a method for efficient burning at over-all lean fuel-air ratios.

Flow properties of particular batches of slurry could be determined before use in combustion evaluation by flowing them through a bench system which would simulate the actual fuel system in which the slurry was to be used. This method would screen out irregular batches and improve the dependability of the slurry systems.

Substantial deposit accumulation in the burner and nozzle sections not only pose a nuisance problem in the operation of experimental equipment, but also emphasize the need for a greater understanding of the

effects of multiphase expansions on the theoretical potentialities for jet-engine use of fuels containing boron.

Lewis Flight Propulsion Laboratory
National Advisory Committee for Aeronautics
Cleveland, Ohio, April 13, 1954

REFERENCES

1. Henneberry, Hugh M.: Effect of Fuel Density and Heating Value on Ram-Jet Airplane Range. NACA RM E51L21, 1952.
2. Lord, Albert M.: An Experimental Investigation of the Combustion Properties of a Hydrocarbon Fuel and Several Magnesium and Boron Slurries. NACA RM E52B01, 1952.
3. Reynolds, Thaine W., and Ingebo, Robert D.: Combustion Efficiency of Homogeneous Fuel-Air Mixtures in a 5-Inch Ram-Jet Type Combustor. NACA RM E52I23, 1952.
4. Farley, John M., Smith, Robert E., and Povolny, John H.: Preliminary Experiments with Pilot Burners for Ram-Jet Combustors. NACA RM E52J23, 1953.
5. Breitwieser, Roland, Gordon, Sanford, and Gammon, Benson: Summary Report on Analytical Evaluation of Air and Fuel Specific-Impulse Characteristics of Several Nonhydrocarbon Jet-Engine Fuels. NACA RM E52L08, 1953.
6. Huff, Vearl N., Gordon, Sanford, and Morrell, Virginia E.: General Method and Thermodynamic Tables for Computation of Equilibrium Composition and Temperature of Chemical Reactions. NACA Rep. 1037, 1951. (Supersedes NACA TN's 2113 and 2161.)
7. Cook, Preston, N., Jr., Lord, Albert M., and Kaye, Samuel: Blow-Out Velocities of Various Petroleum, Slurry, and Hydride Fuels in a $1\frac{7}{8}$ -Inch Diameter Combustor. NACA RM E54A28, 1954.
8. Garmon, R. C., Longo, A., and Wolf, R. L.: Combustion of Boron. TM-555, Quarterly Prog. Rep. July-Sept. 1953, Experiment Inc., Sept. 23, 1953. (Contract AF 33(038)-12633.)

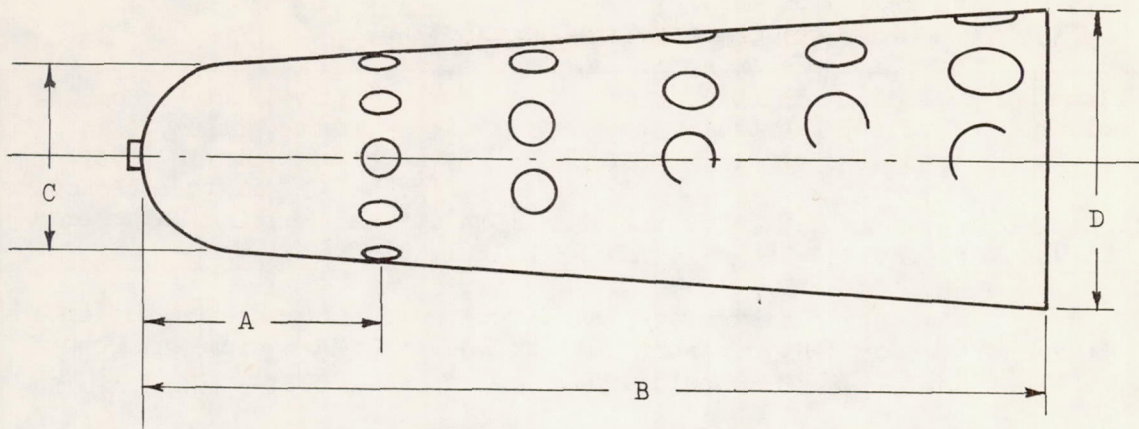

TABLE I. - DIMENSIONS AND DESCRIPTION OF FLAME HOLDERS
USED IN EVALUATION OF BORON SLURRIES

Flame holder	Dimensions, in.				Blockage at dome, percent	Open hole area, percent	Description
	A	B	C	D			
A	$4\frac{1}{2}$	24	$2\frac{1}{4}$	5	24.5	130	Parabolic mixture entry
B-1	4	15	$3\frac{1}{4}$	5	41.0	122	Parabolic mixture entry
B-2	4	15	$3\frac{1}{4}$	5	41.0	122	Addition of scoops to B-1
B-3	4	15	$3\frac{1}{4}$	5	41.0	122	Twelve no. 7 holes in dome of B-1
C-1	$4\frac{1}{2}$	16	4	5	62.5	130	Parabolic air entry, holes in line
C-2	$4\frac{1}{2}$	16	4	5	62.5	130	Twenty $\frac{1}{8}$ " diam. holes in dome of C-1
C-3	$4\frac{1}{2}$	$15\frac{1}{4}$	4	5	62.5	130	Slotted aft section, twenty $\frac{3}{16}$ " diam. holes in dome, linear mixture entry

TABLE II. - PERFORMANCE DATA OBTAINED WITH JP-4 FUEL AND
BORON SLURRY IN 5-INCH RAM-JET COMBUSTOR

(a) Combustor length, 40 inches

Flame holder	Fuel	Air flow, lb/sec	Inlet static pressure, lb/sq ft abs	Inlet mixture temperature, °R	Inlet velocity, ft/sec	Fuel-air ratio, f/a	Equivalence ratio	Heat output, Btu/lb mixture	Combustion efficiency, ^a percent
A	JP-4	1.56	2050	647	188	0.0680	1.000	1080	90.9
	Slurry	1.55	2100	665	188	.1029	1.198	1252	64.6
	Slurry	1.54	2120	667	186	.1082	1.262	1380	67.7
	JP-4	1.53	2120	660	182	.0680	1.000	1027	86.4
	JP-4	1.53	2120	661	183	.0659	.970	1030	89.3
	JP-4	1.51	2120	667	182	.0634	.933	1017	91.4
	JP-4	1.51	2120	669	182	.0603	.887	982	92.5
	JP-4	1.52	2120	673	184	.0561	.827	934	94.1
	JP-4	1.52	2120	---	---	.0550	.810	----	(b)
	JP-4	1.51	2120	667	182	.0659	.970	1010	87.5
	JP-4	1.51	2120	665	181	.0706	1.038	1080	87.7
	JP-4	1.51	2120	---	---	.0743	1.092	----	(c)
B-1	JP-4	1.51	2120	689	188	0.0669	0.984	1067	90.7
	Slurry	1.55	2500	710	169	.1005	1.170	1468	77.3
	Slurry	1.55	2500	---	---	.0949	1.105	----	----
	JP-4	1.19	1780	684	174	.0680	1.000	1065	89.7
	Slurry	1.19	2180	695	145	.0914	1.065	1400	80.4
	Slurry	1.16	2120	693	146	.0853	.993	1263	77.3
	Slurry	1.16	2120	693	146	.0820	.955	1215	73.8
B-2	Slurry	1.16	----	---	---	.0792	.922	----	----
	JP-4	1.16	2120	678	142	0.0694	1.020	1065	87.9
	Slurry	1.16	2120	695	146	.0904	1.053	1355	78.8
	Slurry	1.16	2220	695	138	.0836	.974	1263	78.8
	Slurry	1.16	2140	695	143	.0795	.926	1170	76.5
	Slurry	1.16	2000	695	153	.0754	.884	963	66.1
	Slurry	1.16	1910	695	160	.0726	.846	833	59.2
	Slurry	1.16	1800	695	170	.0695	.810	706	52.3
	Slurry	1.16	1760	695	178	.0664	.774	655	50.6
Slurry	1.16	1690	695	181	.0633	.737	579	46.9	

^aBased on lower heating value of fuel.

^bLean blow-out.

^cRich blow-out.

TABLE II. - Continued. PERFORMANCE DATA OBTAINED WITH JP-4

FUEL AND BORON SLURRY IN 5-INCH RAM-JET COMBUSTOR

(a) Concluded. Combustor length, 40 inches

Flame holder	Fuel	Air flow, lb/sec	Inlet static pressure, lb/sq ft abs	Inlet mixture temperature, °R	Inlet velocity, ft/sec	Fuel-air ratio, f/a	Equivalence ratio	Heat output, Btu/lb mixture	Combustion efficiency, ^a percent
C-1	JP-4	1.35	2120	628	153	0.0675	0.993	990	83.7
	JP-4	1.35	2120	629	153	.0675	.993	1007	85.1
	JP-4	1.35	2120	634	154	.0618	.909	967	89.0
	JP-4	1.35	2120	638	155	.0580	.853	948	92.5
	JP-4	1.35	2120	641	156	.0519	.763	924	99.1
	JP-4	1.35	2120	632	154	.0712	1.048	1060	85.4
	JP-4	1.35	2120	---	---	.0725	1.067	----	(b)
	Slurry	1.28	2350	688	143	.0874	1.013	1252	75.0
Slurry	1.28	2350	676	138	.0936	1.086	1309	73.7	
C-2	Slurry	1.17	2120	675	143	0.0899	1.048	1322	77.1
	Slurry	1.17	2160	675	140	.0833	.971	1243	77.9
	Slurry	1.17	2080	675	146	.0757	.882	1082	74.0
	Slurry	1.17	2310	675	131	.0899	1.048	1357	79.2
	Slurry	1.17	2280	675	132	.0954	1.112	1310	72.4
C-3	JP-4	1.18	2120	661	141	0.0682	1.000	977	81.8
	Slurry	1.18	2120	690	147	.0896	1.044	1171	68.6
	Slurry	1.18	2120	691	147	.0830	.967	1065	67.0
	Slurry	1.18	1990	692	157	.0760	.885	834	56.8
	Slurry	1.18	2220	693	141	.0896	1.044	1246	72.9
	Slurry	1.18	2280	693	137	.0956	1.114	1300	71.7
	Slurry	1.18	2350	694	133	.1023	1.192	1300	67.2
B-3 ^c	JP-4	1.20	2120	666	144	0.0673	0.987	988	83.8
	Slurry	1.20	2200	690	144	.0912	1.060	1170	67.4
	Slurry	1.20	2180	690	145	.0848	.986	1145	70.5
	Slurry	1.20	2120	690	149	.0781	.908	1030	68.5
	Slurry	1.20	2080	690	152	.0723	.841	900	64.2
	Slurry	1.20	2280	690	138	.0848	.986	1180	72.6
	Slurry	1.20	2440	690	130	.0949	1.105	1285	71.3
	Slurry	1.20	1690	690	---	.0610	.710	----	----

^aBased on lower heating value of fuel.^bRich blow-out.^cFirebrick-lined combustor.

TABLE II. - Continued. PERFORMANCE DATA OBTAINED WITH JP-4

FUEL AND BORON SLURRY IN 5-INCH RAM-JET COMBUSTOR

(b) Combustor length, 52 inches

Flame holder	Fuel	Air flow, lb/sec	Inlet static pressure, lb/sq ft abs	Inlet mixture temperature, °R	Inlet velocity, ft/sec	Fuel-air ratio, f/a	Equivalence ratio	Heat output, Btu/lb mixture	Combustion efficiency, ^a percent
B-2	JP-4	1.15	2120	662	138	0.0700	1.030	1060	86.8
	Slurry	1.14	2160	685	138	.0992	1.150	1389	74.1
	Slurry	1.14	2180	684	137	.0928	1.080	1357	77.0
	Slurry	1.14	2180	687	137	.0860	1.000	1340	81.5
B-3	JP-4	1.21	2120	663	145	0.0666	0.977	1020	87.4
	JP-4	1.21	2120	663	145	.0627	.920	1000	90.9
	Slurry	1.21	2120	685	150	.1019	1.187	1340	69.8
	Slurry	1.21	2540	685	124	.0875	1.020	1258	75.1
	Slurry	1.21	2540	685	124	.0875	1.020	1258	75.1
	Slurry	1.21	2540	685	124	.0875	1.020	1251	74.8
	Slurry	1.21	2540	685	124	.0875	1.020	1254	75.0
	Slurry	1.25	2820	685	116	.0874	1.020	1258	75.3
	Slurry	1.25	2820	685	116	.0847	.987	1212	74.8
	JP-4	1.20	2120	651	141	.0674	.991	1046	88.7
	JP-4	1.19	2120	651	140	.0637	.936	1082	96.7
	JP-4	1.19	2120	651	140	.0593	.872	1014	96.9
	JP-4	1.19	2120	653	140	.0549	.807	962	98.9
	JP-4	1.19	2120	657	140	.0504	.741	905	100.9
	JP-4	1.18	2120	657	140	.0491	.722	---	(b)
	JP-4	1.18	2120	648	138	.0684	1.005	1092	91.3
	JP-4	1.18	2120	644	137	.0727	1.069	1096	86.6
	JP-4	1.18	2120	642	137	.0771	1.133	1085	81.1
	JP-4	1.18	2120	639	136	.0814	1.197	1048	74.6
	JP-4	1.18	2120	637	136	.0856	1.258	1026	69.7
	JP-4	1.18	2120	637	136	.0885	1.301	----	(c)
	Slurry	1.18	2200	678	139	.0963	1.122	1285	70.4
	Slurry	1.18	2170	679	141	.0896	1.044	1232	72.1
	Slurry	1.18	2120	681	145	.0828	.965	1135	71.5
Slurry	1.18	2080	683	148	.0762	.888	901	61.2	
Slurry	1.18	2350	678	132	.0963	1.122	1347	73.7	
Slurry	1.18	2460	669	124	.1025	1.194	1340	69.5	

^aBased on lower heating value of fuel.^bLean blow-out.^cRich blow-out.

TABLE II. - Concluded. PERFORMANCE DATA OBTAINED WITH JP-4

FUEL AND BORON SLURRY IN 5-INCH RAM-JET COMBUSTOR

(b) Concluded. Combustor length, 52 inches

Flame holder	Fuel	Air flow, lb/sec	Inlet static pressure, lb/sq ft abs	Inlet mixture temperature, °R	Inlet velocity, ft/sec	Fuel-air ratio, f/a	Equivalence ratio	Heat output, Btu/lb mixture	Combustion efficiency, ^a percent
B-2	JP-4	1.18	2120	664	140	0.0685	1.008	1048	87.5
	JP-4	1.17	2120	663	140	.0648	.955	1038	91.4
	JP-4	1.17	2120	667	141	.0557	.819	932	99.7
	JP-4	1.17	2120	660	140	.0500	.736	---	(b)
	Slurry	1.17	2180	683	140	.1080	1.230	1325	65.4
	Slurry	1.17	2240	683	136	.1012	1.152	1412	74.2
	Slurry	1.17	2240	683	136	.0942	1.072	1318	73.6
	Slurry	1.17	2220	683	137	.0870	.991	1335	80.2
	Slurry	1.17	2180	683	140	.0870	.991	1235	74.1
	Slurry	1.17	2330	683	131	.1012	1.152	1330	69.8
	Slurry	1.17	2350	683	130	.1080	1.230	1455	71.8
	JP-4	1.20	2120	644	140	.0674	.992	1030	87.3
	JP-4	1.20	2120	644	140	.0631	.929	1039	93.8
	JP-4	1.20	2120	645	140	.0587	.864	976	95.1
	JP-4	1.20	2120	647	140	.0543	.799	941	97.8
	JP-4	1.20	2120	648	140	.0525	.772	---	(b)
	JP-4	1.20	2120	643	139	.0674	.992	1060	89.9
	JP-4	1.20	2120	639	138	.0715	1.052	1070	86.0
	JP-4	1.20	2120	637	138	.0758	1.115	1080	81.0
	JP-4	1.20	2120	635	138	.0800	1.177	1046	75.6
	JP-4	1.20	2120	633	137	.0842	1.239	1025	70.7
	JP-4	1.20	2120	631	137	.0886	1.303	----	(c)
	Slurry ^d	1.19	2480	663	123	.0919	1.033	1308	74.7 ^e
Slurry ^d	1.19	2480	663	123	.0984	1.070	1365	72.9	
Slurry ^d	1.19	2480	663	123	.0984	1.070	1378	73.5	

^aBased on lower heating value of fuel.^bLean blow-out.^cRich blow-out.^d86.5 Percent boron, 12.5 percent magnesium material.^eBased on lower heating value of 20,908 Btu/lb fuel.

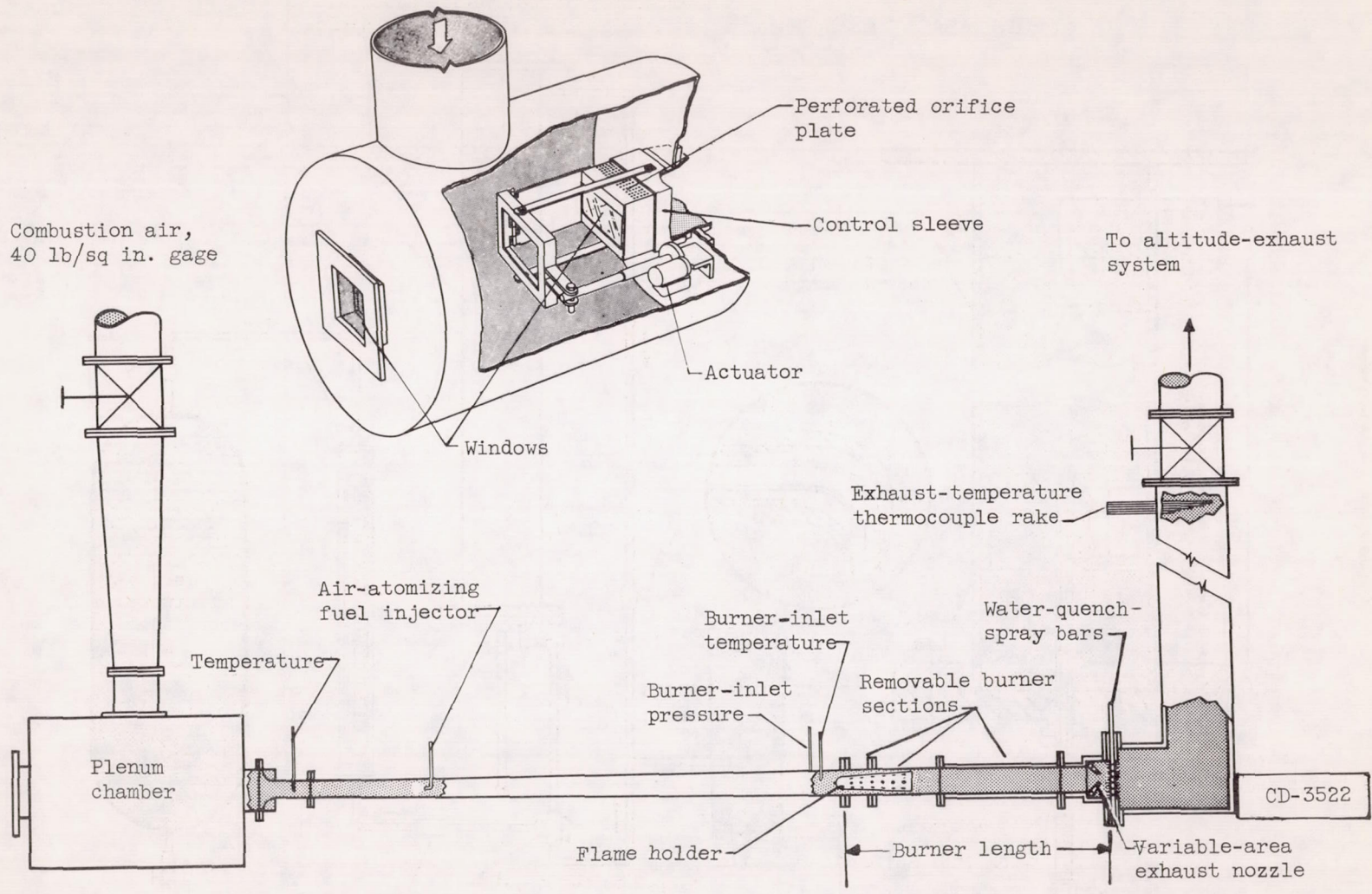

Figure 1. - Schematic diagram of 5-inch ram-jet burner.

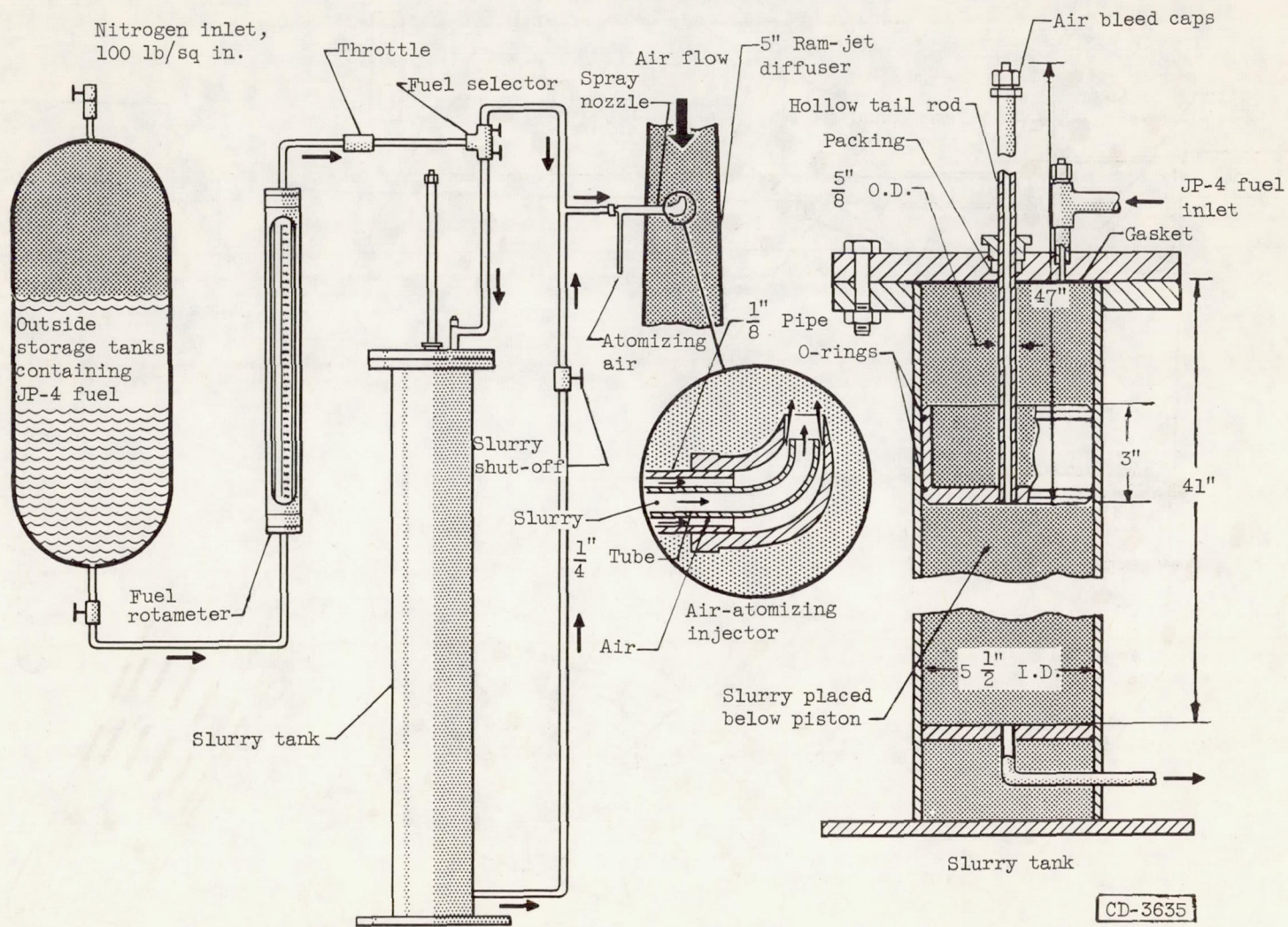

Figure 2. - Diagram of fuel system including details of slurry fuel tank and air-atomizing injector.

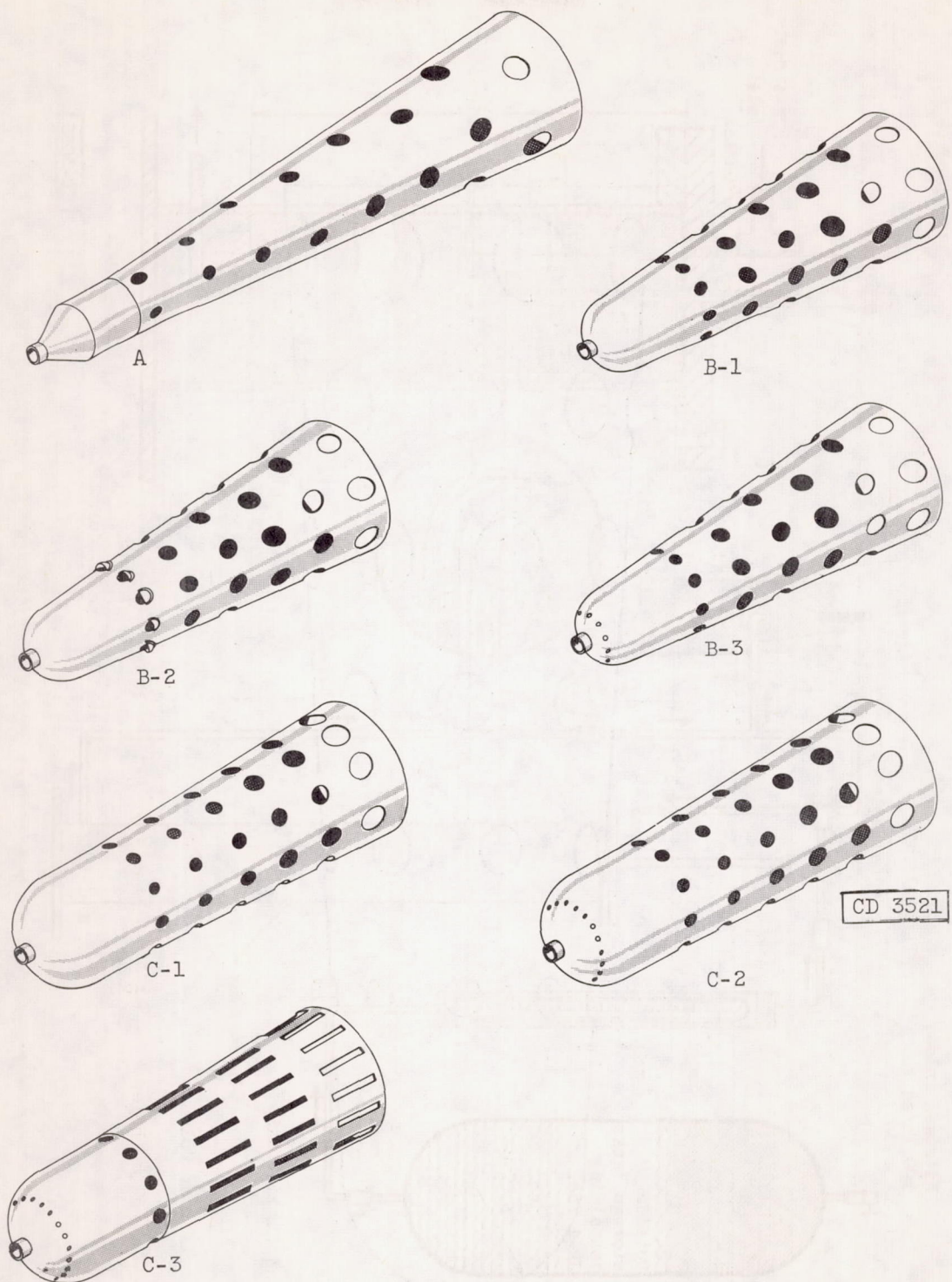

Figure 3. - Flame holders developed for evaluation of boron slurries,

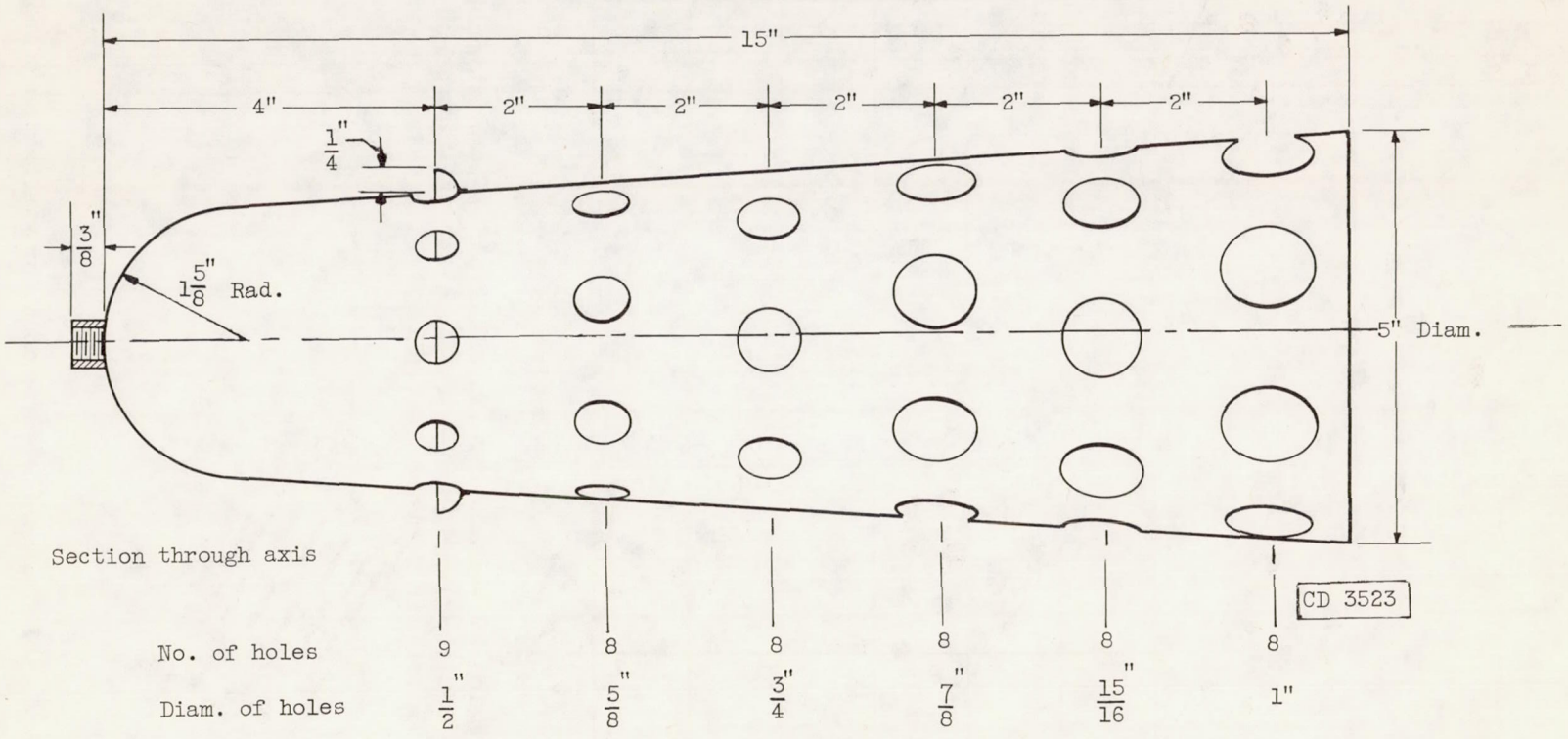

Figure 4. - Details of flame holder B-2.

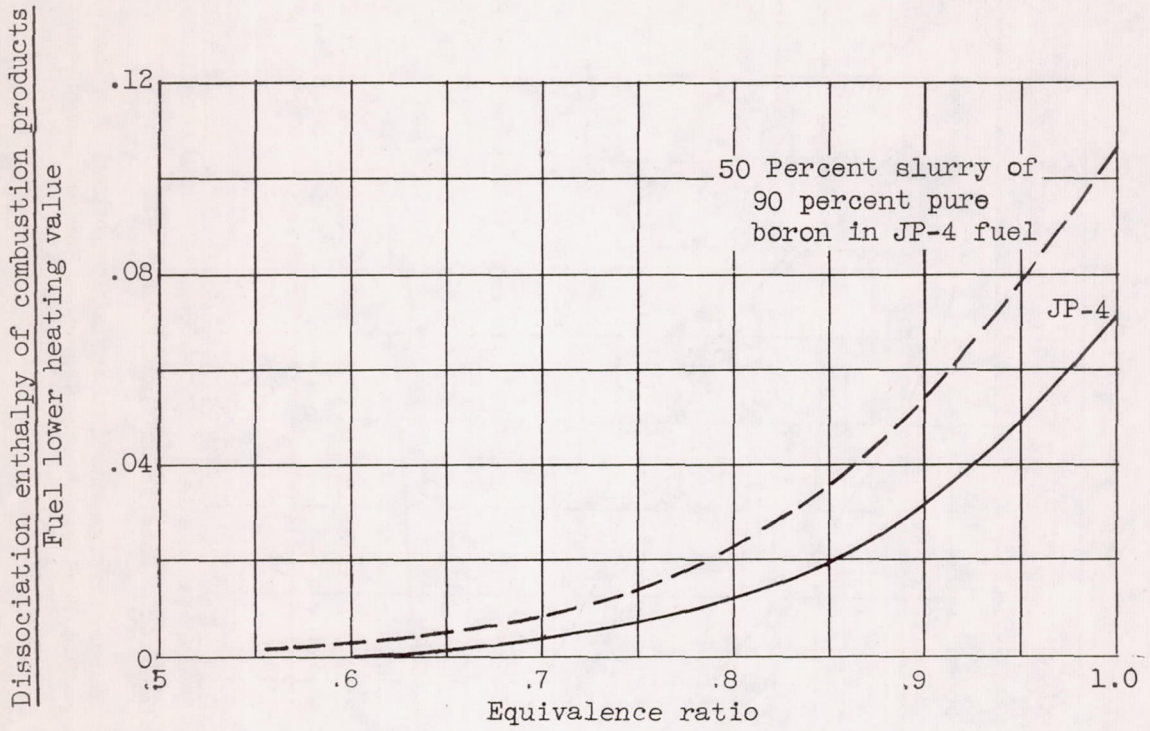

Figure 5. - Dissociation enthalpy of combustion products at equilibrium for JP-4 fuel and 50-percent-boron slurry. Inlet air temperature, 660° R.

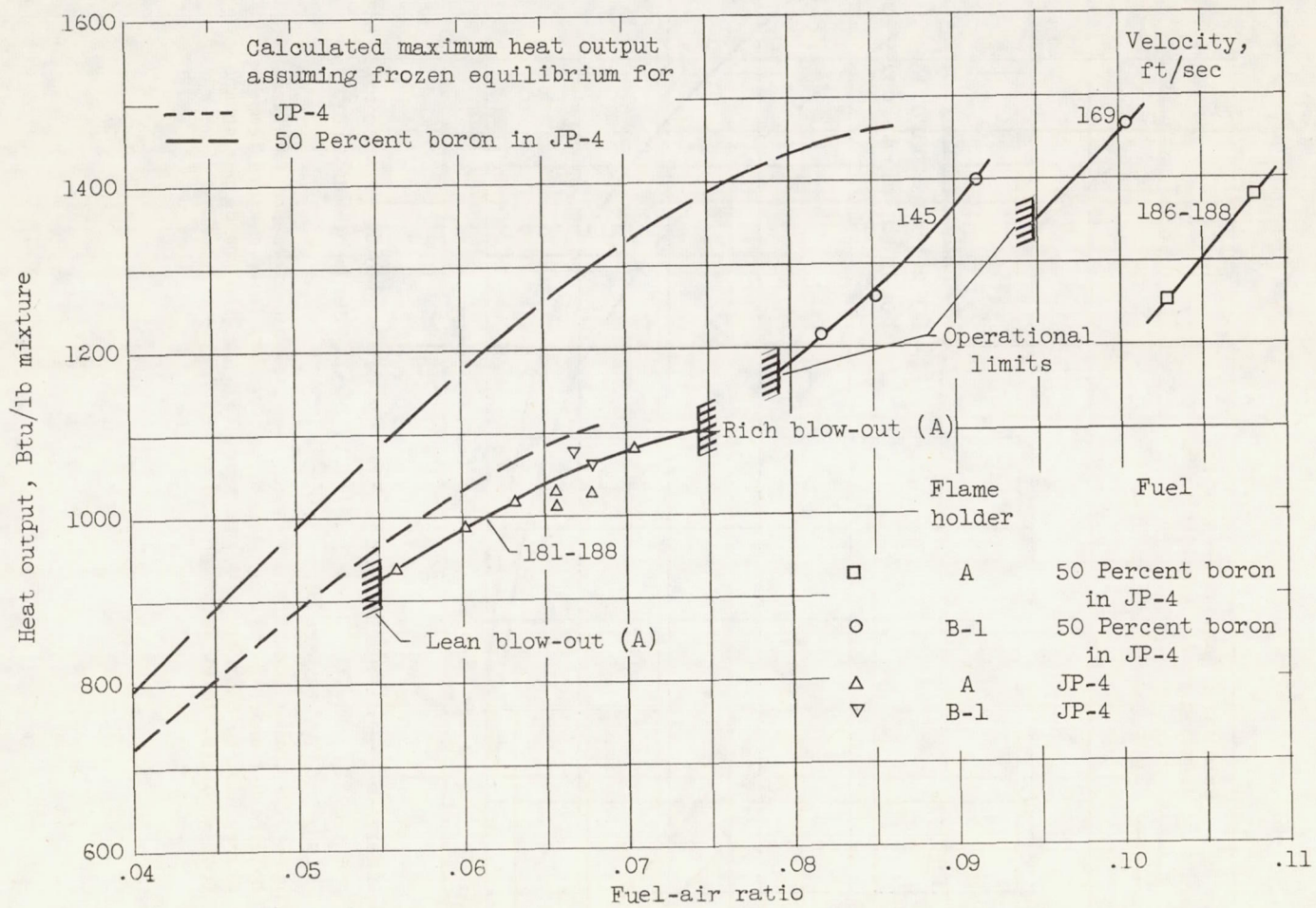

Figure 6. - Effect of burner design and inlet mixture velocity on heat output and stability limits for JP-4 fuel and boron slurry. Burner length, 40 inches; inlet mixture temperature, 665° to 710° R; inlet pressure, 1778 to 2495 pounds per square foot absolute.

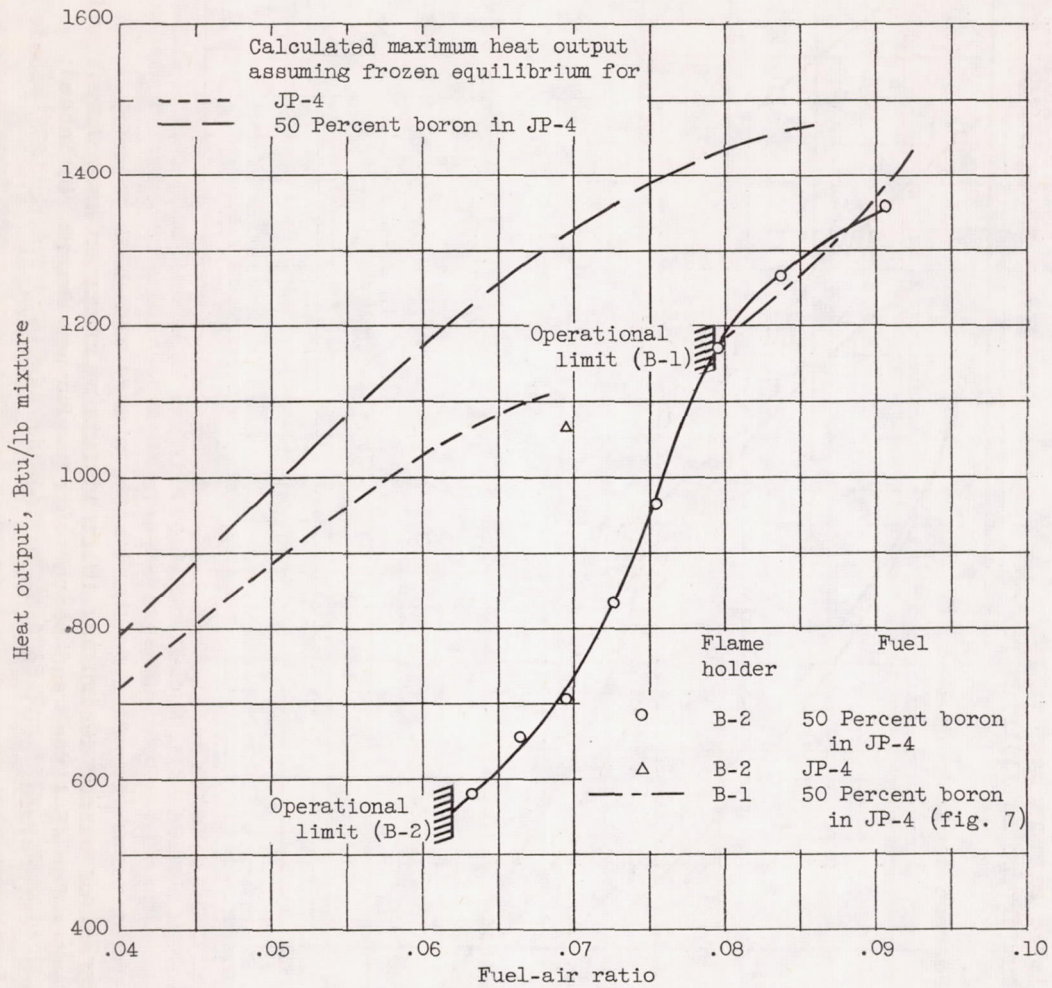

Figure 7. - Comparison of boron slurry combustion performance for flame holders B-1 and B-2. Burner length, 40 inches; inlet mixture temperature, 678° to 695° R; inlet pressure, 1698 to 2135 pounds per square foot absolute; inlet velocity, 138 to 181 feet per second.

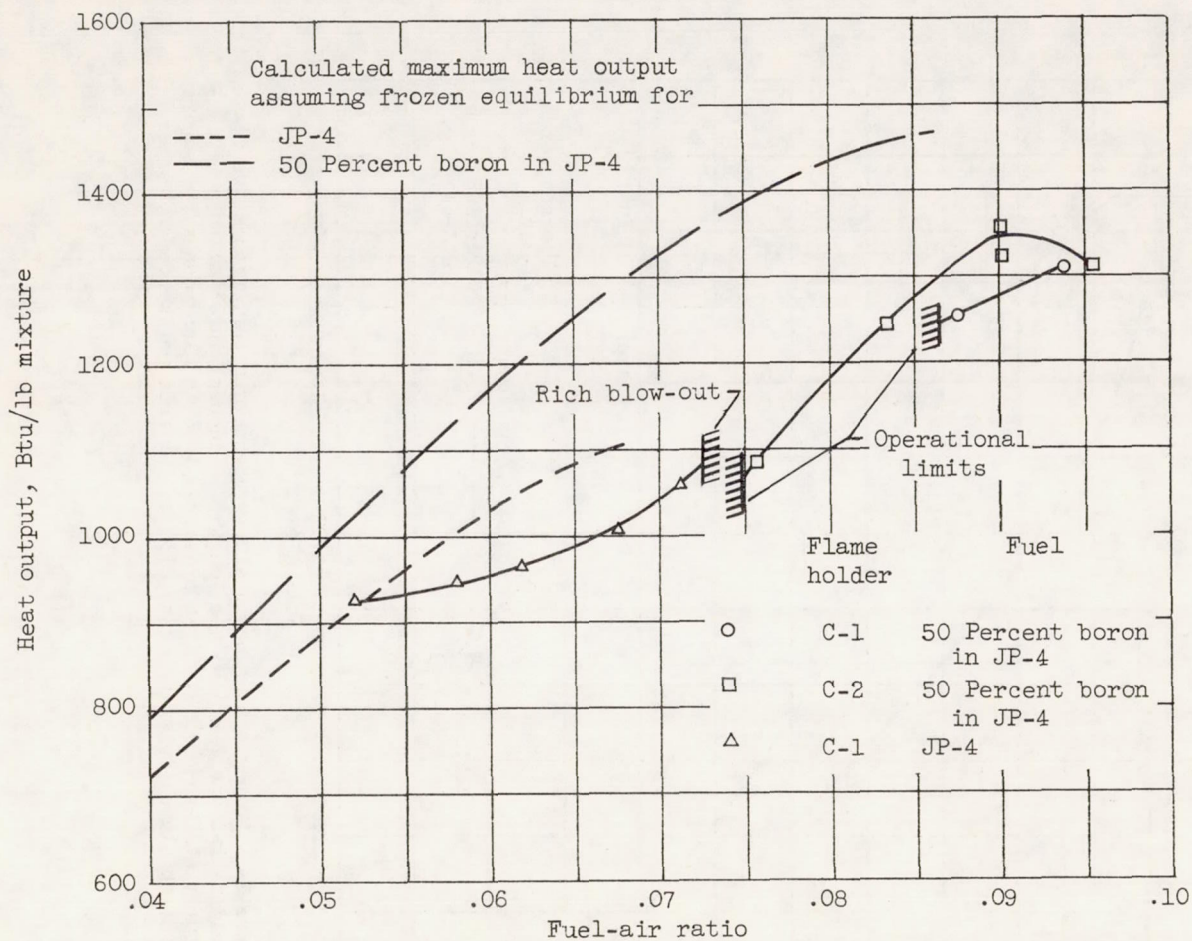

Figure 8. - Heat output for JP-4 fuel and boron slurry with high-pressure-drop flame holders. Burner length, 40 inches; inlet mixture temperature, 628° to 688° R; inlet pressure, 2118 to 2395 pounds per square foot absolute; inlet velocity, 133 to 156 feet per second.

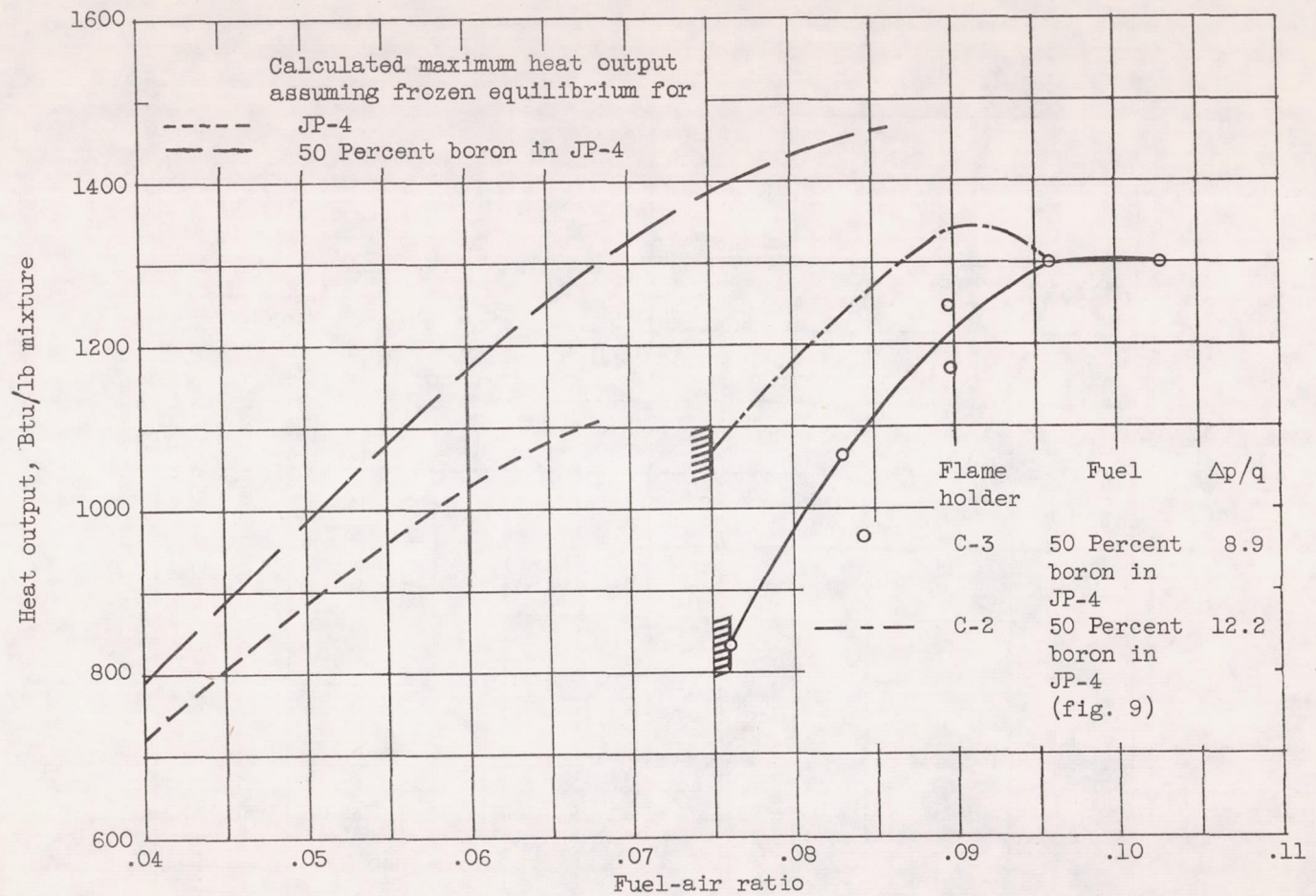

Figure 9. - Performance of flame holders C-2 and C-3 with boron slurry. Burner length, 40 inches; inlet mixture temperature, 628° to 694° R; inlet pressure, 1991 to 2395 pounds per square foot absolute; inlet velocity, 131 to 157 feet per second.

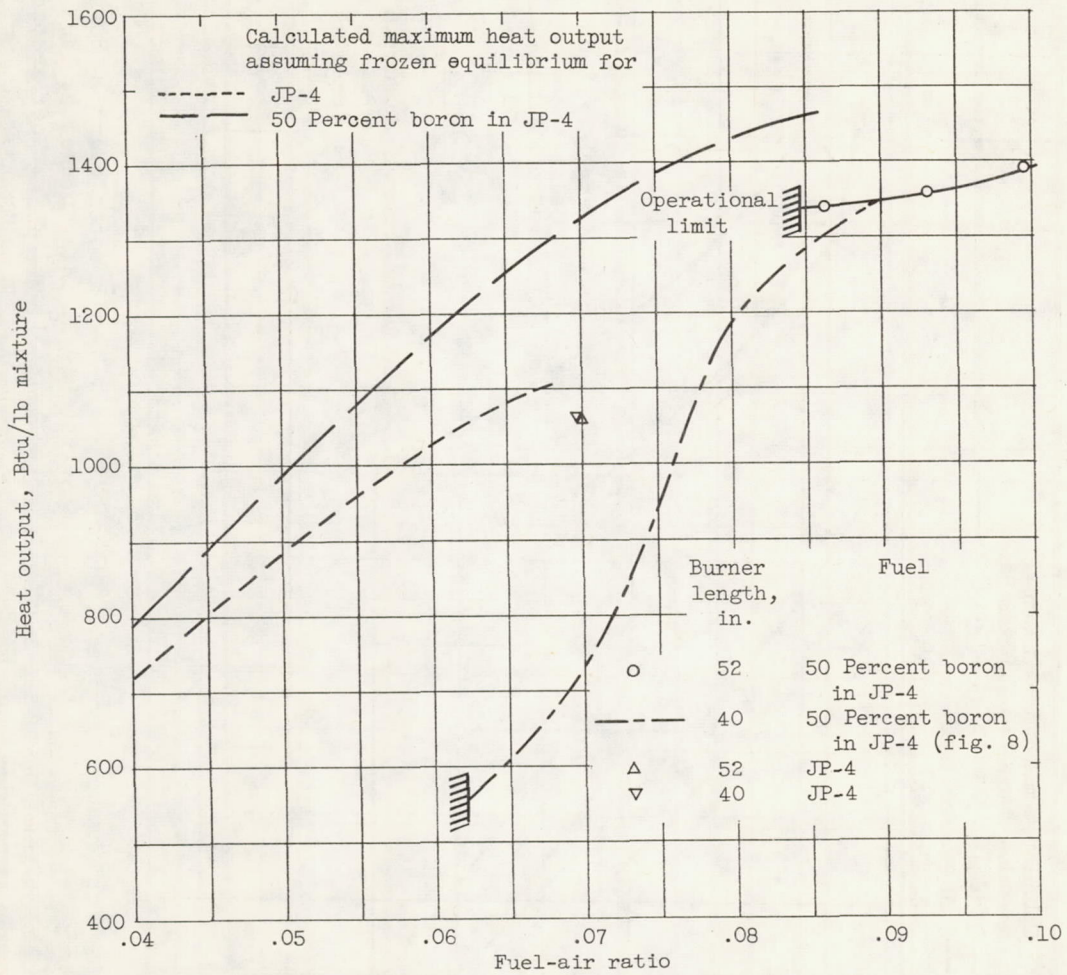

Figure 10. - Effect of burner length on heat output of boron slurry and JP-4 fuel. Flame holder B-2; inlet mixture temperature, 678° to 695° R; inlet pressure, 1692 to 2135 pounds per square foot absolute; inlet velocity, 137 to 181 feet per second.

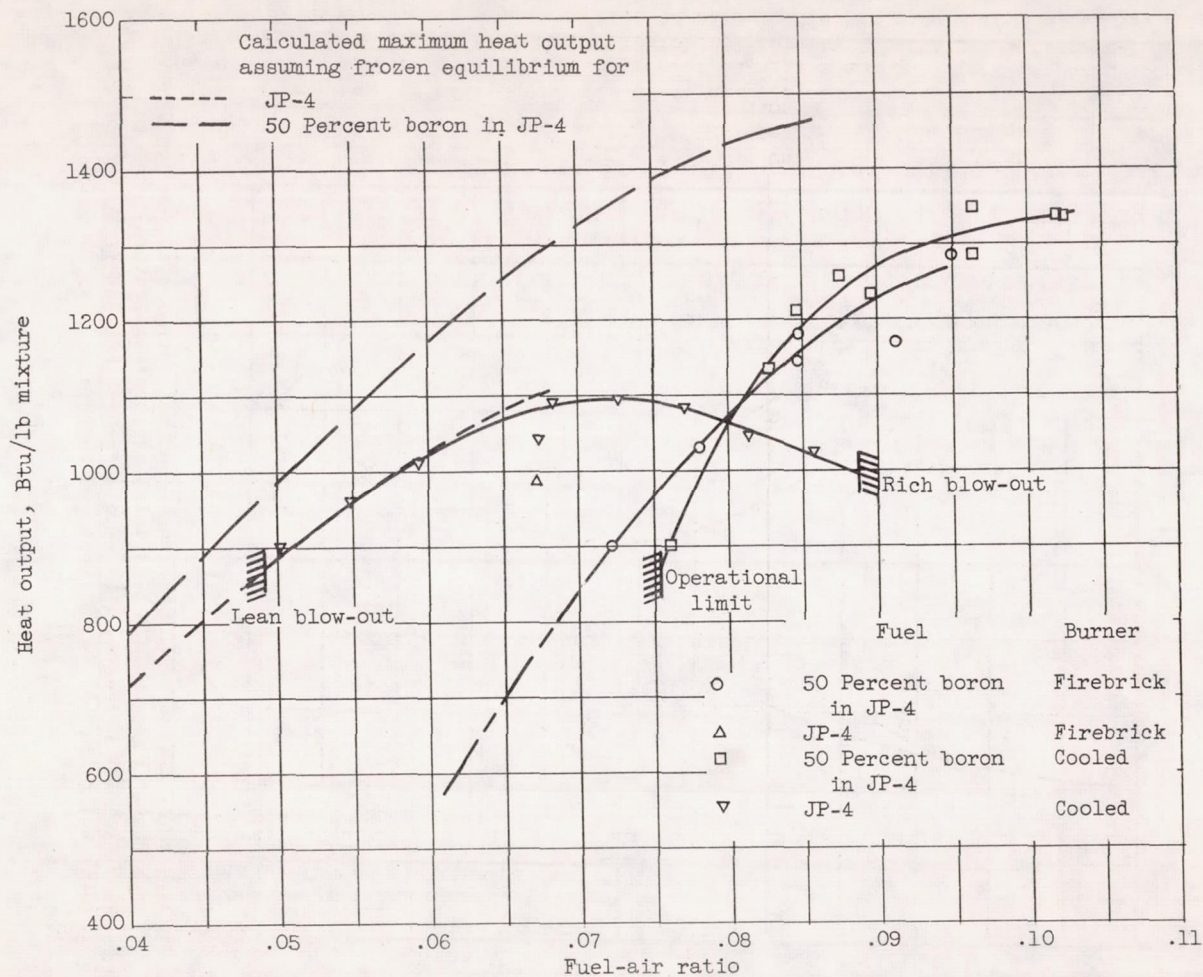

Figure 11. - Comparison of heat output of boron slurry and JP-4 fuel in 40-inch firebrick-lined burner and in 52-inch cooled burner. Flame holder B-3; inlet mixture temperature, 631° to 690° R; inlet pressure, 1692 to 2820 pounds per square foot absolute; inlet velocity, 116 to 152 feet per second.

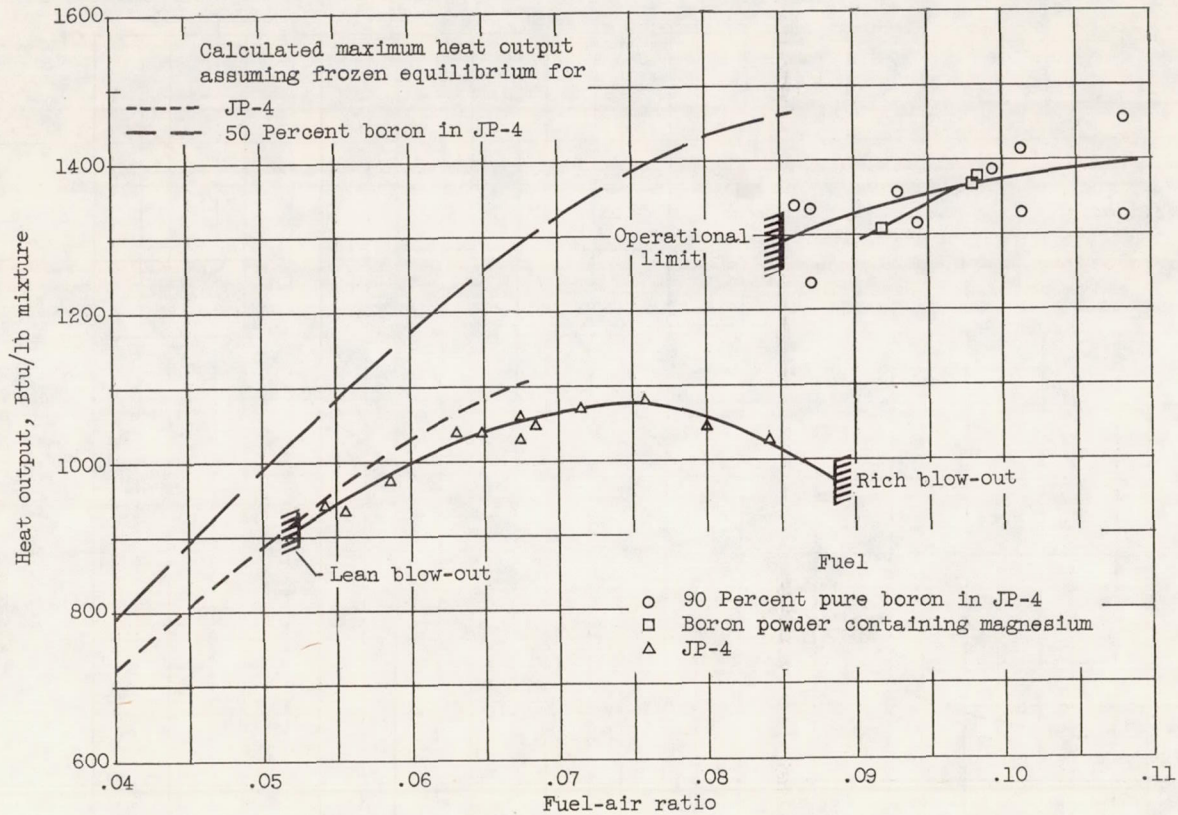

Figure 12. - Comparison of heat output for JP-4 fuel and slurries of 90 percent pure boron, and boron powder containing 12.5 percent magnesium and 86.5 percent boron in JP-4 fuel. Flame holder B-2; burner length, 52 inches; inlet mixture temperature, 631° to 695° R; inlet pressure, 2118 to 2478 pounds per square foot absolute; inlet velocity, 123 to 148 feet per second.

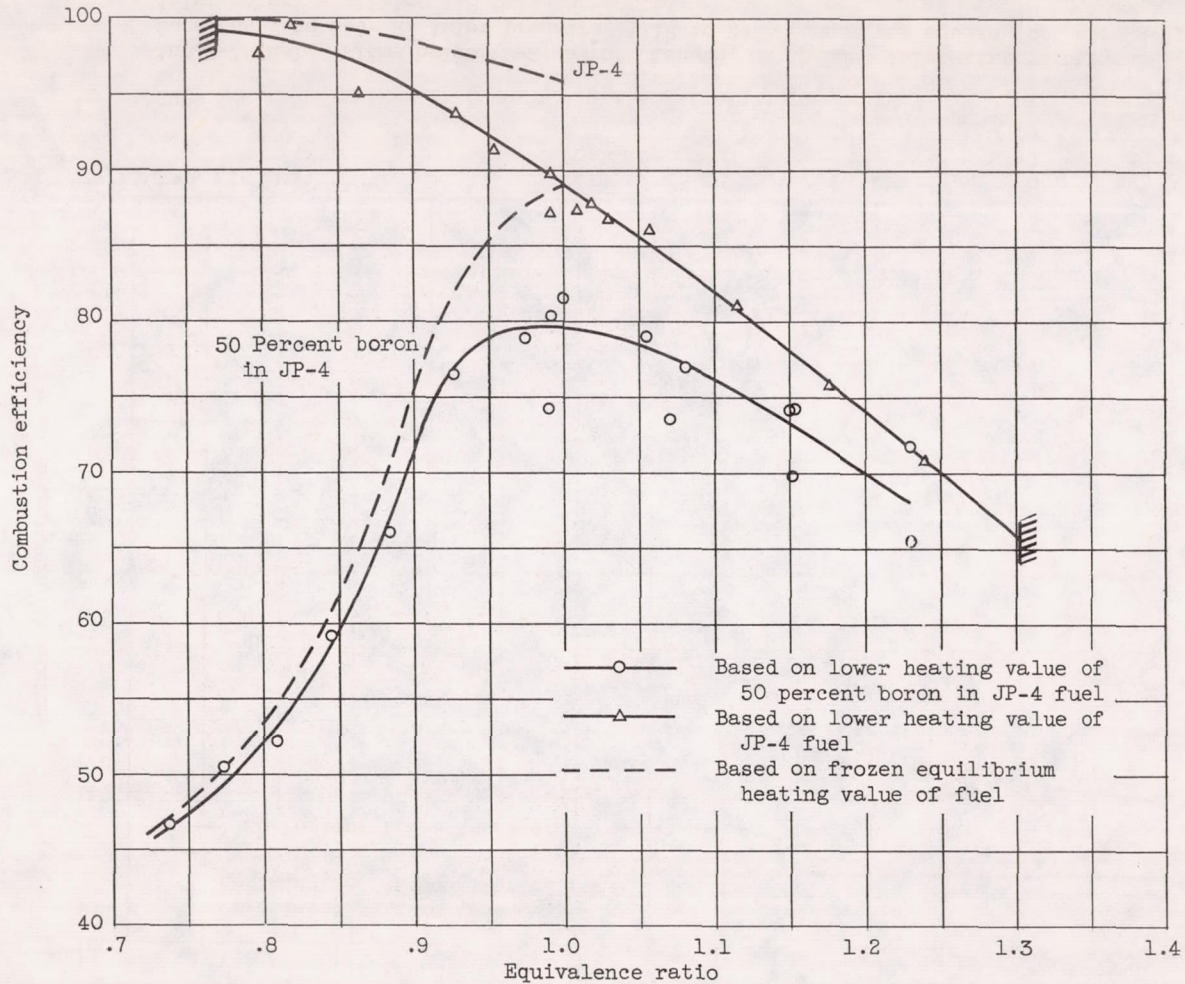

Figure 13. - Comparison of combustion efficiencies of JP-4 fuel and boron slurry. Flame holder B-2; burner length, 40 and 52 inches; inlet mixture temperature, 631° to 695° R; inlet pressure, 1692 to 2478 pounds per square foot absolute; inlet velocity, 123 to 181 feet per second.

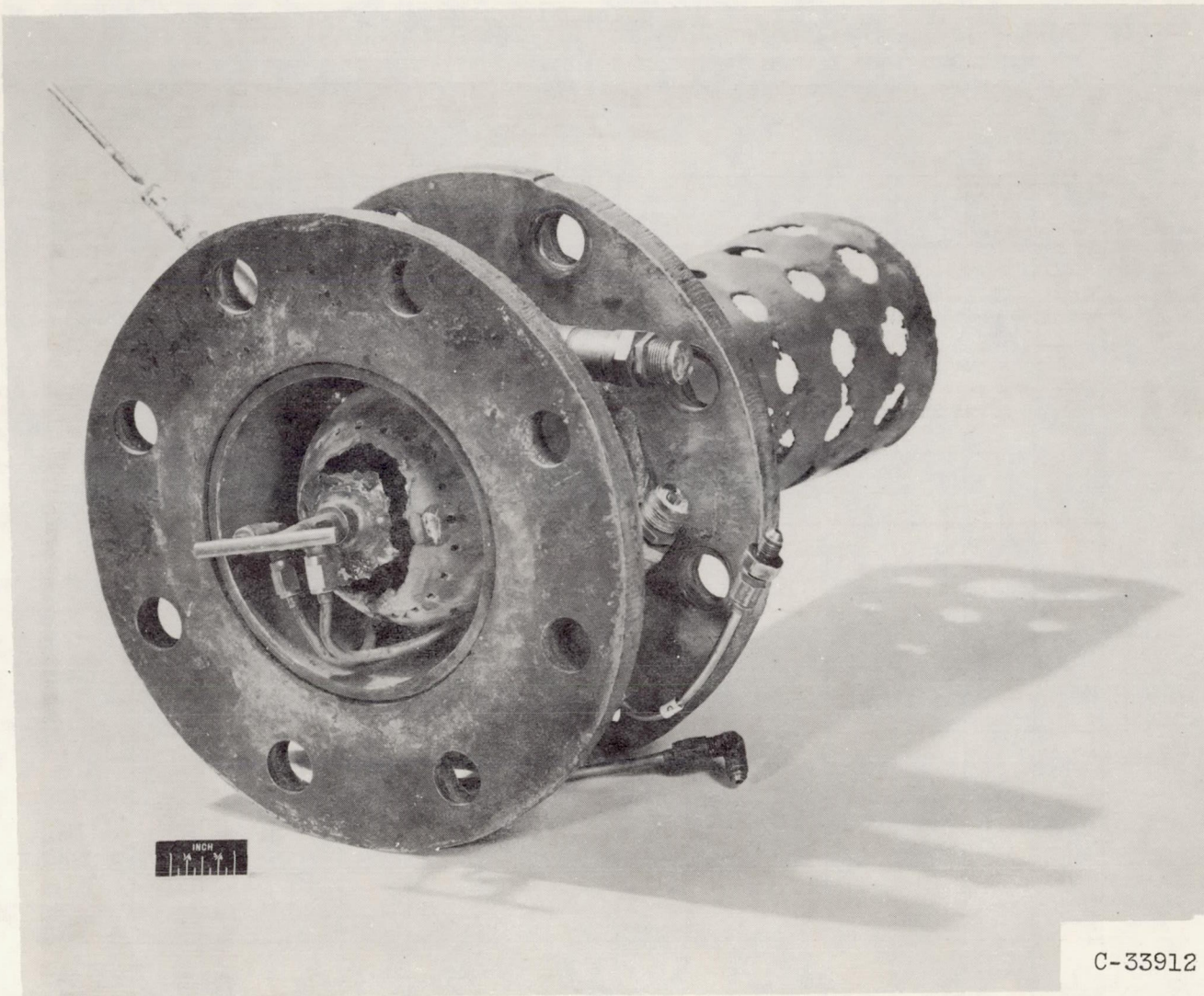

Figure 14. - Damage to dome and aft portions of flame holder C-2 after run with boron slurry.

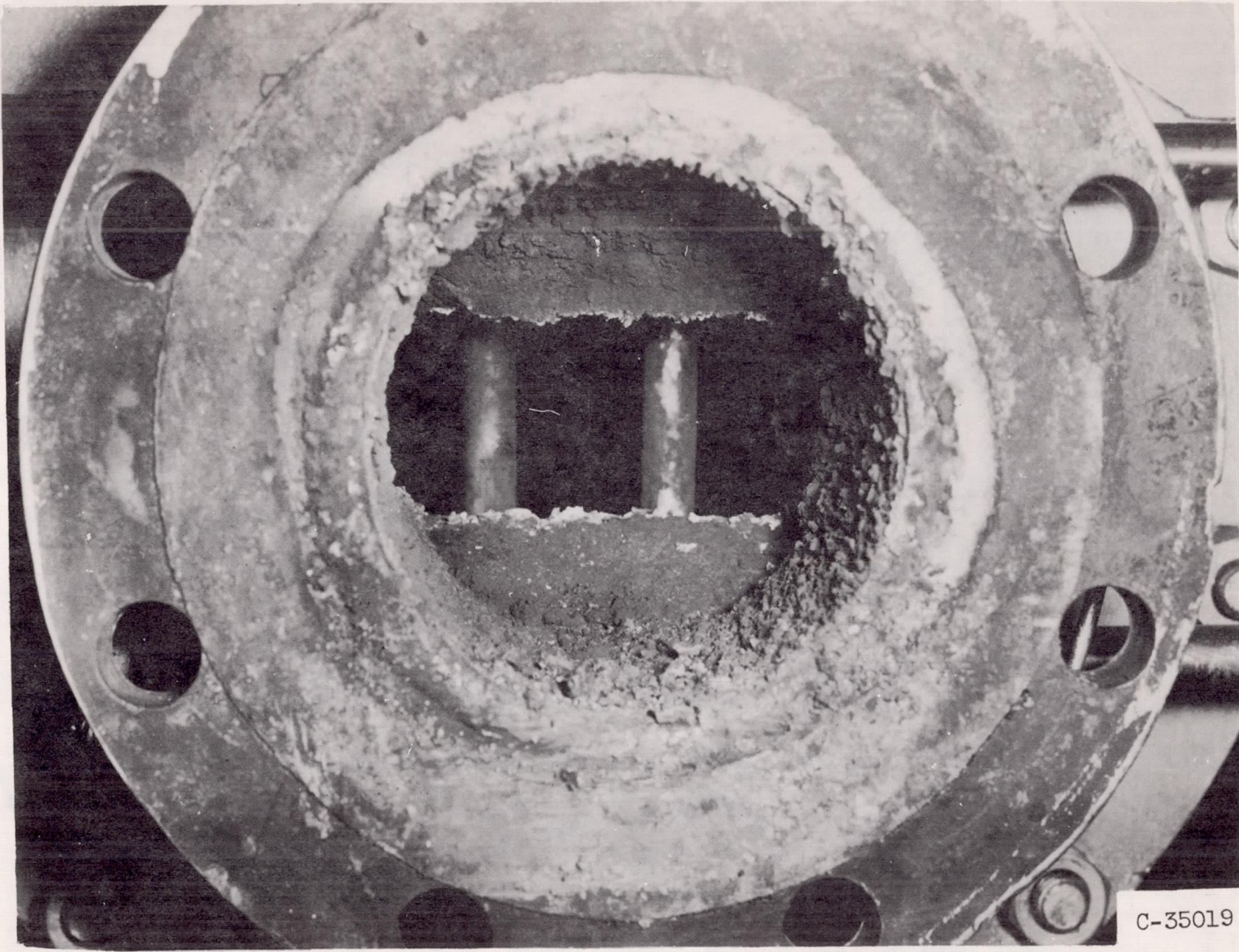

Figure 15. - Variable-area nozzle section after burning boron slurry.

