

# RESEARCH MEMORANDUM

ALUMINUM BOROHYDRIDE - HYDROCARBON MIXTURES AS A  
SOURCE OF IGNITION FOR A TURBOJET COMBUSTOR

By Hampton H. Foster, Edward A. Fletcher, and David M. Straight

Lewis Flight Propulsion Laboratory  
Cleveland, Ohio

NATIONAL ADVISORY COMMITTEE  
FOR AERONAUTICS  
WASHINGTON

February 23, 1955  
Declassified September 3, 1958



## NATIONAL ADVISORY COMMITTEE FOR AERONAUTICS

RESEARCH MEMORANDUMALUMINUM BOROHYDRIDE - HYDROCARBON MIXTURES AS A SOURCE  
OF IGNITION FOR A TURBOJET COMBUSTORBy Hampton H. Foster, Edward A. Fletcher,  
and David M. Straight

## SUMMARY

An investigation was conducted to determine the feasibility of using aluminum borohydride - hydrocarbon mixtures as a source of ignition in a single tubular turbojet-engine combustor. The hydrocarbon diluents investigated were isopentane, JP-4 fuel, and mineral oil. The combustor was operated on a modified JP-4 fuel. The combustor-inlet air pressures that limited ignition were determined for air flows in the range of engine altitude starting conditions. Ignition limits observed with single injections of 2 cubic centimeters of the igniting mixtures were compared with those obtained with electric spark systems and with the steady-state burning limits of the combustor at similar flows.

The combustor ignition limits obtained with a 40 percent by volume solution of aluminum borohydride in JP-4 fuel were almost as good as those with undiluted aluminum borohydride for the range of altitude inlet conditions investigated. With 10 and 20 percent concentrations, the ignition characteristics were very erratic. Altitude pressures which limited ignition with the 40 percent blend were about 2 inches of mercury lower than those obtained with a 10-joule electric spark system and were within 2 to  $3\frac{1}{2}$  inches of mercury of the steady-state burning limits of the combustor. These results were obtained with 0.025-inch-diameter capillary injection tubes; larger tubes (0.075 and 0.20 in. diam) resulted in poorer ignition limits.

At a combustor-inlet air temperature of  $10^{\circ}$  F, mineral oil and JP-4 fuel blends ignited the combustor with approximately equal effectiveness. At  $-40^{\circ}$  F, better results were obtained with mineral oil blends. Very poor ignition characteristics were obtained with isopentane as the diluent.

In an extension of the present work, aluminum borohydride was successfully used as a stand-by ignition source for a 48-inch ram-jet engine.

## INTRODUCTION

The problem of in-flight ignition of thermal-jet engines becomes more difficult with the ever increasing demand for higher flight speeds and higher altitude operation of the engines. Means of ignition other than conventional electric sparks are being investigated at the NACA Lewis laboratory. This report describes the use of dilute solutions of aluminum borohydride for ignition of a turbojet engine combustor. Its use as a stand-by ignition source for a 48-inch ram-jet engine is also described.

Successful ignition has been obtained with single small injections of aluminum borohydride at combustor conditions far more severe than those which limited ignition with an experimental high-energy electric spark system (ref. 1). This chemical is one of a number of compounds that are spontaneously flammable in air and have a high rate of energy release. Although excellent ignition characteristics were obtained, practical difficulties in the use of aluminum borohydride could be expected because of its tendency to plug injectors, to volatilize, and to build up high pressures in containers under storage conditions in high-speed aircraft.

In the static-chamber tests reported in reference 1, ignition was obtained with blends of aluminum borohydride in a hydrocarbon fuel. The results indicate that such blends could be more easily handled and introduced into the combustor and less prone to plug injectors and to build up pressures in closed containers. A study was therefore undertaken at the NACA Lewis laboratory to evaluate the ignition characteristics of dilute solutions of aluminum borohydride in a single tubular turbojet combustor. Three different diluents were used, isopentane, MIL-F-5624B, grade JP-4 fuel, and mineral oil. Ignition mixtures of 2-cubic centimeters containing 10, 20, 40, and 100 percent aluminum borohydride by volume were packaged in pressurized glass capsules with capillary metering tubes; the tubes were broken to introduce the ignition mixtures into the combustor. A 0.025-inch-diameter injector capillary tube was used to obtain most of the data; however, comparative data were also obtained with tubes of two larger diameters (0.075 and 0.20 in.).

The combustor-inlet air pressures which limit burning and those which limit ignition were determined for three air flows (in the range of altitude engine windmilling conditions) using a modified JP-4 fuel. The combustor-inlet air and fuel temperatures were held constant at 10° F. Data were also obtained at low (-40° F) combustor-inlet air and fuel temperatures for one air-flow rate. The combustor ignition limits obtained with the several concentrations of aluminum borohydride were compared with those obtained with spark systems at energy levels of 0.3 and 10 joules and with the steady-state burning limits of the combustor.



Data on the extent of decomposition of a sample of aluminum borohydride during long-term storage are presented.

#### APPARATUS AND PROCEDURE

A single J33 turbojet-engine combustor (fig. 1) was installed in a direct-connect duct test facility, which supplied the desired combustor-inlet and -exhaust conditions. The test facility and instrumentation for indicating combustor-inlet and -outlet air total pressures, air and fuel temperatures, and air and fuel flows are described in detail in reference 2. A large (3- by 11.5-in.) transparent plastic window in the outer shell of the combustor permitted visual observation of the flame. A 10.5-gallon-per-hour, fixed-area fuel nozzle having an 80° spray-cone angle was used in this investigation. The fuel passed through a copper cooling coil (50 ft long and 3/8-in. O.D.) immediately before entering the nozzle (fig. 1); the fuel temperature was, therefore, very near that of the inlet air. The combustor was supplied with a low-volatility, modified MIL-F-5624B, grade JP-4 fuel; analysis of the fuel is given in table I.

#### Ignition Systems

Aluminum borohydride system. - Aluminum borohydride was introduced into the combustor from an injector designed to fit into the spark-plug hole (fig. 1). A detailed diagrammatic sketch of the injector is presented in figure 2. A glass capsule containing 2-cubic centimeters of the aluminum borohydride mixture was mounted in the injector as shown in figure 2. A manually operated trigger arm was used to break the sealed tip from the capillary tube, allowing the contents of the capsule to be injected into the combustion chamber. The capillary tubes had an inside diameter of 0.025 inch for most runs. (All tubes were notched 3/4 inch from the main body of the capsule to provide a reproducible breaking point.) The capsule and injector designs were generally similar to those described in reference 1. Ignition capsules were charged as follows. The desired amount of hydrocarbon diluent was first introduced into the open capsule by means of a pipette or burette and the capsule stoppered with a self-sealing biological-vial rubber stopper. The capsule was then cooled in a dry-ice slush bath and the air evacuated through a hypodermic needle. Aluminum borohydride was then added in the desired amount from a calibrated burette equipped with a similar hypodermic needle. The capsule was finally pressurized with nitrogen to slightly above 1 atmosphere through a third hypodermic needle. The capsules were stored in powdered dry ice until shortly before firing; just before they were inserted into the injector they were warmed by hand so that the contents would be thoroughly mixed.



Electric system. - The electric spark-ignition system used to obtain comparative data is described in detail in reference 3. Energy levels of 0.3 and 10 joules of stored condenser energy per spark with a spark rate of 8 sparks per second were used (estimated efficiency, 20 to 25 percent of stored energy available at spark gap).

#### Test Procedure

Burning limits. - For comparison with ignition-limit data, the minimum combustor-inlet air pressures at which burning could be maintained were determined for three air flows (1.87, 3.75, and 6.0 lb/(sec)(sq ft), based on a combustor maximum cross-sectional area of 0.267 sq ft) at constant air and fuel temperatures of 10° F. A description of the method used to determine the combustor limits is presented in reference 3.

Ignition limits with aluminum borohydride - hydrocarbon blends. - The minimum combustor-inlet air pressures at which ignition of the combustor could be obtained were determined for inlet conditions similar to those for the burning-limit tests (air flows: 1.87, 3.75, and 6.0 lb/(sec)(sq ft) at 10° F). After the desired inlet conditions were established, fuel was admitted at a rate previously determined to be optimum for ignition by sparks (fuel-air ratio, approx. 0.015). The aluminum borohydride - hydrocarbon blend was then injected into the fuel-air mixture. Ignition was indicated by a temperature rise and by observation of flame through the window in the combustor. Except with a few injections of 10 and 20 percent blends, flame was always visible, at least momentarily, whether or not the combustor was successfully ignited. The criterion for satisfactory ignition was that the flame filled the combustor and continued after the igniting fluid had been expended.

Although a few preliminary tests were made with isopentane as the diluent, most of the data were obtained with JP-4 fuel as the diluent; the aluminum borohydride concentrations were 10, 20, 40, and 100 percent. Some data were also obtained with a 40 percent aluminum borohydride concentration with mineral oil as the diluent.

Ignition limits with electric sparks. - The minimum combustor-inlet air pressure at which ignition could be obtained with a spark-energy level of 0.3 and 10 joules (at 8 sparks/sec) was determined for the aforementioned combustor-inlet flow and temperature conditions. A detailed description of the ignition procedure used is presented in reference 3.

#### RESULTS

Turbojet-combustor ignition data obtained with aluminum borohydride and aluminum borohydride - hydrocarbon blends over a range of combustor-inlet air conditions are presented in table II. These data will be



compared with ignition data obtained with an electric spark ignition system and with combustor steady-state burning-limit data (also included in table II).

The initial part of this investigation was conducted with aluminum borohydride blends containing isopentane as the diluent. The static-chamber tests of reference 1 had indicated that aluminum borohydride blends of a similar fuel, n-pentane, containing as little as 20 mole percent aluminum borohydride were spontaneously flammable at pressure and temperature conditions far more severe than those encountered in turbojet-engine operation. Preliminary combustor ignition tests with isopentane containing 40 percent aluminum borohydride, however, were successful in starting the combustor at or near sea-level pressure conditions only (see table II). Because it was considered that excessively rich vapor fuel-air mixtures may have existed in the ignition zone when isopentane was used, or possibly because of the high spontaneous ignition temperature of isopentane, subsequent tests were performed with diluents of lower volatility and, incidently, lower spontaneous ignition temperature.

#### Ignition Limits of Aluminum Borohydride - JP-4 Fuel Blends

Effect of air-flow rate. - Combustor ignition-limit data for aluminum borohydride concentrations of 10, 20, 40, and 100 percent in JP-4 fuel are shown in figure 3. The injector capillary was 0.025 inch in diameter. Several chemical-ignition-data points are presented for each test condition. In general, the inlet pressures that limited ignition increased with an increase in air flow as was expected from previous research (ref. 1). The indication of the reverse trend with the 20 percent aluminum borohydride blend is probably insignificant in view of the observed scatter of the data points. The 10 percent blends failed to ignite at the highest air flow (6 lb/(sec)(sq ft)), and only occasionally was combustor ignition obtained even at the lower air flows. The 20 percent concentrations ignited and combustor ignition was obtained at all the air flows. Combustor ignition with either the 10 or 20 percent concentration was quite erratic. With the blends containing 40 percent aluminum borohydride, there was a marked improvement in ignition characteristics. The minimum pressures for ignition were reduced and ignition was much more consistent. The ignition limits obtained with the 40 percent aluminum borohydride blend were almost equivalent to those obtained with the undiluted aluminum borohydride.

The data presented in figure 3 are summarized in figure 4 for comparison with the combustor steady-state burning limits and with ignition limits obtained with electric spark systems. The ignition limits obtained with the 40 percent aluminum borohydride blend are about 2 inches of mercury lower than those obtained with the 10-joule spark system and are within 2 to 3.5 inches of mercury of the steady-state burning limits



of the combustor. A spark energy of 10 joules (stored energy) represents the probable upper energy limit for proposed electric spark systems. The 0.3 joule (stored energy) ignition-limit curve shown was obtained in a previous investigation (ref. 3) and represents the energy level supplied by one turbojet-engine ignition system at 20 sparks per second. At a combustor-inlet pressure of 15 inches of mercury absolute (0.5 atm), the air-velocity ignition limits of the 40 percent aluminum borohydride blend were about 30 percent greater than those of the 10-joule spark system and more than double those of a 0.3-joule spark system.

The ignition limits obtained in this study with undiluted aluminum borohydride were somewhat lower than those reported in reference 1, probably because of improved metering. They are within about 1.5 to 2 inches of mercury of the combustor burning limits. Sudden changes in the air pressure or fuel flow at these conditions resulted in flame-out. For this particular combustor, these burning limits are below the limits at which an engine could be easily accelerated.

Effect of inlet air temperature. - The effect of combustor-inlet air temperature on ignition limits was investigated with the 40 percent aluminum borohydride blend only; the results are presented in figure 5. The minimum pressure for ignition increased about 10 inches of mercury with a decrease in inlet air temperature from 10° to -40° F. As noted in figure 5, this increase was considerably greater than that previously observed (ref. 1) with either the undiluted aluminum borohydride or the spark system. An inspection of the capsule just before firing at -40° F showed that the aluminum borohydride and the JP-4 fuel were well mixed and flowed freely in the capsule. The appearance of the flame flash was similar to that observed at the 10° F temperature condition. The capillary tube diameter was 0.025 inch for these tests.

Effect of injection duration. - Figure 6 shows the effect of injection duration on the combustor ignition limits. The time intervals shown were obtained from high-speed motion-picture films of the flame flashes of the igniter fluid in the combustor. Increase in injection duration improved the ignition limits considerably. The ignition limit would be expected to approach closely the combustor burning limit with even longer injection times. Increases in injection duration also increased the probability of ignition; that is, ignition was more consistent with longer injection durations.

#### Ignition Limits with Aluminum Borohydride - Mineral Oil Blend

It was previously noted that considerably better ignition characteristics were obtained when the volatility of the diluent incorporated into the blend was reduced. Thus, ignition was improved when JP-4 fuel replaced isopentane as the diluent. It was therefore considered desirable



to obtain combustor ignition data with an aluminum borohydride diluent even less volatile than JP-4 fuel. Mineral oil was chosen for additional ignition tests inasmuch as it is readily available for such an application and is relatively free of unsaturated hydrocarbons, which react with aluminum borohydride.

Figure 7 compares combustor ignition limits for 40 percent aluminum borohydride blends of the two diluents, at one air flow (3.75 lb/(sec) (sq ft)) and two inlet air temperatures. At 10° F, the ignition limit of the aluminum borohydride - mineral oil blend is at least somewhat lower than that of the aluminum borohydride - JP-4 blend; none of the five capsules tried failed to ignite the combustor. With a decrease in inlet air temperature from 10° to -40° F, the ignition-limiting pressure for the aluminum borohydride - mineral oil blend increased about 3 inches of mercury, which is about the same change as that obtained with pure aluminum borohydride and with the spark-ignition system (ref. 1). The corresponding change in ignition limits for the aluminum borohydride - JP-4 fuel blends is considerably greater. The capillary injection tube of 0.025-inch diameter was used for both mixtures.

#### Ignition with Aluminum Borohydride in 48-Inch Ram-Jet Engine

The encouraging results obtained in the ignition tests with aluminum borohydride and with aluminum borohydride blends led to the use of aluminum borohydride for ignition of a 48-inch experimental ram-jet engine installed in an altitude chamber at the Lewis laboratory (ref. 4). The aluminum borohydride was packaged in 1- and 2-cubic-centimeter quantities in glass capsules. To obtain ignition, a capsule was fired by air pressure through a long steel tube into the combustor (fig. 8). Impact of the capsule upon the walls of the ram-jet pilot broke the capsule, releasing the aluminum borohydride in the region of the pilot fuel spray. The ram-jet engine was operated on MIL-F-5624B, grade JP-5 fuel. Some results of the ignition trials are presented in table III and figure 9. The ignition limits obtained with aluminum borohydride were considerably better with this combustor at low air flows than those obtained with an electric spark system (subsequent work with other combustor configurations has shown that the spark-ignition limits can be considerably improved by changes in combustor design). Insufficient data were obtained at the higher air flows to establish a pressure limit. It is believed that even better ignition characteristics might be obtained with a more refined injection technique.

#### Aluminum Borohydride Decomposition

One reason for considering the use of dilute solutions of aluminum borohydride in place of pure aluminum borohydride is the decomposition



that may occur during storage. Only meager experience with hydrocarbon blends is available to indicate the seriousness of the problem. The following information was obtained in storing undiluted aluminum borohydride at the Lewis laboratory.

In the summer of 1947, a 1000-cubic-centimeter steel tank containing 380-cubic centimeters of aluminum borohydride was stored in an outdoor shed and left undisturbed until February 1954. The hydride had thus undergone storage for about  $6\frac{1}{2}$  years at prevailing outdoor temperatures. Careful inspection of the tank prior to its being opened revealed no evidence of leaks. The hydrogen pressure inside the tank at the end of the  $6\frac{1}{2}$  years had risen from 0 to 150 pounds per square inch gage. This increase corresponds to the liberation of about 16 volumes of hydrogen gas (at atmospheric pressure) per volume of liquid aluminum borohydride originally present, or about 2 percent of the hydrogen potentially available. Thus, decomposition did not seriously reduce the quantity of aluminum borohydride available, but the resulting pressure rise must be considered in the design of the container.

#### DISCUSSION

There is ample evidence that undiluted aluminum borohydride will ignite a conventional hydrocarbon fuel in a turbojet combustor near the burning limit and that the ignition limits were better than those obtained with a 10-joule (stored energy) spark-ignition system. It was predicted in reference 1 that longer injection duration would improve ignition limits. Two possible methods of accomplishing this increase with a given quantity of chemical are (1) making use of capillary injection tubes of smaller diameters, or (2) diluting the aluminum borohydride with hydrocarbons to increase the total volume of the liquid injected.

The data presented in this report indicate the trend of improved ignition limits obtainable with longer injection duration resulting from decreasing the diameter of the capillary injection tube. A minimum practical diameter may exist, however, since the use of small capillaries may be conducive to injector plugging difficulties. Plugging of the capillaries was not experienced in the present investigation even with the smallest diameter capillary, 0.025 inch. These capsules were pressurized with nitrogen, which suggests that some of the plugging difficulties reported in reference 1 may have been due to insufficient pressure in the capsule. The propane used as the propellant gas in the tests of reference 1 was probably appreciably soluble in the aluminum borohydride and hence reduced the pressure available for injecting the aluminum borohydride into the combustor. Even so, experience gained during this and related research indicated that the plugging problem associated with



metering tubes and orifices should be considered in the design of chemical injection systems.

The second method of obtaining longer injection duration, the use of aluminum borohydride - hydrocarbon blends, would also appear to alleviate the plugging problem, since liquid-flow rates would be higher and the potential amount of ash per unit volume of fluid injected would be lower. Suitable mixtures would also have a lower volatility during storage in the high-temperature aircraft environments encountered at high-speed flight conditions. The primary objective of the present investigation was to determine the effect on ignition limits of blending aluminum borohydride with hydrocarbons. The data presented indicate that aluminum borohydride can be diluted with hydrocarbons to at least as low as 40 percent aluminum borohydride and yet retain ignition performance that is nearly as good as that obtained with the undiluted aluminum borohydride.

The volatility and viscosity of the hydrocarbons used in the mixtures would be expected to play an important role in ignition with the system used in this investigation. For example, isopentane blends, containing the most volatile hydrocarbon, had the poorest ignition limit, whereas mineral oil blends, containing the least volatile diluent had the best ignition limit (particularly at  $-40^{\circ}$  F). It should be noted that isopentane also has a higher spontaneous ignition temperature. It is believed that excessively rich vapor fuel-air mixtures may have existed in the ignition zone when the highly volatile isopentane was used.

The viscosity of the diluents affects the flow rate and thus affects ignition. Mineral oil, being much more viscous than either JP-4 fuel or isopentane, increased the injection duration through the capillary tube and thus aided ignition. The lower concentrations of aluminum borohydride in JP-4 fuel, although having somewhat higher viscosity than undiluted aluminum borohydride, gave poorer ignition limits. This was due simply to dilution and lower flammability. At the combustor-inlet temperature of  $-40^{\circ}$  F, mineral oil as a diluent considerably improved the ignition limit over that of JP-4 fuel as a diluent. This improvement is probably due to the increased injection duration resulting from the greatly increased viscosity of mineral oil at the lower temperature.

Other methods of injecting aluminum borohydride into a combustor may prove feasible now that it has been established that aluminum borohydride is still a good ignition source when diluted with hydrocarbons. For example, aluminum borohydride could be fed into one or more of the main fuel nozzles on an engine in such a manner that dilution of the aluminum borohydride with fuel is not excessive. A technique such as this may prove useful in overcoming some of the current ignition and acceleration problems as well as the more severe problems anticipated in future engines.



Engines are already being operated under conditions such that if a flame-out were to occur, combustor-inlet temperature and pressure would drop to near the burning limits of the combustors. It is anticipated that these conditions will become even more severe in the future. For example, if a supersonic turbojet-powered aircraft were to encounter flame-out near its operational ceiling, the combustor-inlet pressure and temperature would drop to well below the burning limit of the combustor with conventional fuels. Continued improvement in combustor design will help alleviate both the burning and the starting problems. Even so, with conventional fuels, starting is limited by the low pressures and temperatures regardless of the design of the combustor. An ignition source having a much higher heat-release rate than the spark-ignition systems currently used will be required if present-day fuels are used. It is believed that chemical ignition may supply the required high energies. A type of continuous chemical ignition source is visualized that can be used on demand for the required interval and furnish enough heat to ignite and stimulate burning of the combustor fuel to the point where there is sufficient heat release to improve burning conditions and accelerate the engine.

The general term "chemical ignition" is used here to indicate that there are many other chemical compounds which could be expected to give similar results and may have more desirable physical or chemical properties than aluminum borohydride. It is believed that continued research on chemical ignition is warranted in view of the potential gains possible.

#### SUMMARY OF RESULTS

From an investigation to determine the feasibility of using aluminum borohydride diluted with hydrocarbons as a source of ignition for a turbojet combustor operating on a modified JP-4 fuel, the following results were obtained with single injections (2 cc) from pressurized glass capsules.

1. The combustor ignition limits obtained with a 40 percent concentration of aluminum borohydride in JP-4 fuel were almost as good as those obtained with undiluted aluminum borohydride for the range of altitude inlet conditions investigated. The ignition characteristics were erratic with aluminum borohydride concentrations of 10 and 20 percent.

2. Altitude pressures which limited ignition with the 40 percent aluminum borohydride - JP-4 fuel blend were about 2 inches of mercury lower than those attained with a 10-joule spark system, and were within 2 to 3.5 inches of mercury of the combustor steady-state burning limits.



3. At an inlet temperature of  $10^{\circ}$  F, mineral oil was at least as good a diluent as JP-4 fuel; at  $-40^{\circ}$  F better results were obtained with mineral oil as the diluent. Very poor ignition characteristics were obtained with isopentane as the diluent.

4. In general, increasing the duration of injection resulted in improved ignition characteristics.

5. Aluminum borohydride was successfully used as an ignition source for a 48-inch ram-jet engine in an altitude test setup.

Lewis Flight Propulsion Laboratory  
National Advisory Committee for Aeronautics  
Cleveland, Ohio, November 17, 1954

#### REFERENCES

1. Straight, David M., Fletcher, Edward A., and Foster, Hampton H.: Aluminum Borohydride as an Ignition Source for Turbojet Combustors. NACA RM E53G15, 1953.
2. Dittrich, Ralph T., and Jackson, Joseph L.: Altitude Performance of AN-F-58 Fuels in J33-A-21 Single Combustor. NACA RM E8L24, 1949.
3. Foster, Hampton H.: Ignition-Energy Requirements in a Single Tubular Combustor. NACA RM E51A24, 1951.
4. Meyer, Carl L., and Welna, Henry J.: Investigation of Three Low-Temperature-Ratio Combustor Configurations in a 48-Inch-Diameter Ram-Jet Engine. NACA RM E53K20, 1954.



TABLE I - FUEL ANALYSIS

Fuel Property	NACA fuel 50-197 (modified MIL-F-5624B grade JP-4
A.S.T.M. distillation D86-46, °F	
Initial boiling point	181
Percentage evaporated	
5	242
10	271
20	300
30	319
40	332
50	351
60	356
70	381
80	403
90	441
Final boiling point	508
Residue, percent	1.2
Loss, percent	0.2
Reid vapor pressure, lb/sq in.	1.0
Hydrogen-carbon ratio	0.170
Heat of combustion, Btu/lb	18,691
Specific gravity	0.780
Freezing point, °F	< -76
Viscosity, centistokes at 100° F	1.05

TABLE II. - IGNITION DATA WITH ALUMINUM BOROHYDRIDE - HYDROCARBON MIXTURES PACKAGED IN PRESSURIZED GLASS CAPSULES

Run	Combustor air flow, lb (sec)(sq Ft)	Over-all fuel-air ratio	Quantity injected, cc	Concentration aluminum borohydrate, percent	Capillary size, in.	Combustor inlet		Diluent	Observation
						Pressure, in. Hg abs	Temperature, °F		
1	1.87	0.018	2.0	40	0.20	12.0	10	Isopentane	Flame, no start
2					15.0	Flame, no start			
3					20.0	Flame, no start			
4					25.0	Flame, no start			
5					32.0	Starts and continues			
6	3.75	.0114	2.0	40	.075	12.5	10	Isopentane	Flame, no start
7					25.0	Flame, no start			
8					25.0	Flame, no start			
9					12.0	Good start, blows out after several sec			
10					11.15	No start, burns several sec <sup>a</sup>			
11	6.0	.011	2.0	40	0.20	12.0	10	JP-4 fuel	Start, blows out after several sec <sup>a</sup>
12						15.0			Excellent start, blows out 10 sec later
13						11.0			Excellent start, blows out 10 sec later
14						10.0			Excellent start, continues
15						9.0			Excellent start, continues for several sec
16	3.75	.0114	2.0	40	0.20	8.5	10	JP-4 fuel	Excellent start, blows out
17						15.0			Excellent start, continues
18						14.0			Excellent start, continues
19						13.0			Excellent start, continues
20						12.0			Excellent start, continues
21	6.0	.011	2.0	40	0.20	11.0	10	JP-4 fuel	Excellent start, continues
22						10.6			Excellent start, continues
23						17.0			Excellent start, continues
24						15.0			Excellent start, continues
25						15.0			Excellent start, continues
26	3.75	.0114	2.0	40	0.20	14.0	10	JP-4 fuel	Good light, blows out
27						10.0			Good light, blows out
28						19.5			Good light, blows out
29						11.0			Good light, continues several sec
30						16.0			Good start, continues
31	6.0	.011	2.0	40	0.20	15.0	10	None	Good start, continues
32						14.0			Good light, blows out
33						10.6			Good light, blows out
34						10.5			Excellent start, continues
35						9.5			Good light, blows out
36	3.75	.0114	2.0	40	0.20	10.0	10	JP-4 fuel	Excellent start, continues
37						14.0			Good light, blows out after several sec
38						14.5			Good start, continues
39						18.0			Good start, continues
40						17.0			Good light, blows out
41	6.0	.011	2.0	40	0.20	17.5	10	None	Good start, continues
42						14.0			Good start, continues
43						12.0			Good light, blows out
44						8.0			Good light, blows out after several sec
45						8.3			Lights, burns several sec
46	1.87	.018	2.0	40	0.20	11.0	10	JP-4 fuel	Small light, blows out
47						12.0			Small light, blows out
48						13.0			Small light, blows out
49						14.0			Small light, blows out
50						16.0			Small light, blows out
51	3.75	.0114	2.0	40	0.20	29.5	10	None	Excellent start, continues
52						21.5			Good light, blows out after several sec
53						23.3			Good light, blows out after several sec
54						25.0			Good start, continues
55						14.0			Good start, continues
56	6.0	.011	2.0	40	0.20	12.0	10	JP-4 fuel	Good start, continues
57						13.0			No light
58						13.0			No light
59						14.0			Light, blows out
60						14.0			Good light, blows out
61	1.87	.018	2.0	40	0.20	16.0	10	None	Good light, blows out after several sec
62						17.0			Good light, blows out
63						17.0			Small light, blows out
64						29.2			No light
65						29.2			No light
66	3.75	.0114	2.0	40	0.20	28.5	10	JP-4 fuel	Good start, continues
67						21.5			Good light, blows out
68						23.0			Good start, continues
69						22.0			Good light, blows out
70						14.0			Good light, blows out
71	6.0	.011	2.0	40	0.20	16.0	10	None	Good light, blows out
72						18.0			Good light, blows out
73						21.0			Good light, blows out
74						24.0			Good start, continues
75						23.0			Good start, continues
76	1.87	.018	2.0	40	0.20	22.0	10	JP-4 fuel	Good start, continues
77						22.0			Good start, continues
78						22.0			Good start, continues
79						20.0			Good start, continues
80						18.0			Good start, continues
81	3.75	.0114	2.0	40	0.20	18.0	10	None	Good start, continues
82						26.3			No light
83						29.0			No light

<sup>a</sup>Fuel flow may have been inadequate.



TABLE II. - Concluded. IGNITION DATA WITH ALUMINUM BOROHYDRIDE - HYDROCARBON MIXTURES PACKAGES IN PRESSURIZED GLASS CAPSULES

Run	Combustor air flow, lb (sec)(sq ft)	Over-all fuel-air ratio	Quantity injected, cc	Concentration aluminum borohydrate, percent	Capillary size, in.	Combustor inlet		Diluent	Observation
						Pressure, in. Hg abs	Temperature, °F		
84	3.75	0.0114	2.0	10	0.025	28.7	10	JP-4 fuel	Good start, continues
85						22.0			Good start, continues
86						18.0			Good light, blows out
87						20.5			Fair light, blows out
88	1.87	.018				22.7			Fair light, blows out
89						24.0			Good start, continues
90	6.0	.011				30.0			No flame
91	1.87	.018		20		24.0			Light, blows out
92						26.0			Good start, continues
93						25.0			No light
94						25.0			Good light, no start
95				100		25.5		None	Good light, no start
96						8.8			Good light, burner continues several sec
97						8.5			Good light, burner continues several sec
98						8.9			Good light, burner continues several sec
99	3.75	.0114				10.2			Good start, continues
100	6.0	.011				14.3			Good start, continues
101						14.0			Good light, blows out
102						14.3			Good start, continues
103						14.1			Good start, continues
104	3.75	.0114		40		13.5	-40	Mineral oil	No light
105						13.5	-42		Good start, continues
106						13.0	-41		Good light, no start
107						13.5	-42		Good light, blows out after several sec
108						14.0			Good light, blows out
109						15.0		JP-4 fuel	Good light, blows out
110						16.0			Good light, blows out
111						17.0			Good light, continues for few sec
112						16.0			Good light, continues for few sec
113						19.0			Good light, continues for few sec
114						27.0	-40		Good start, continues
115						24.0	-40		Good start, continues
116						12.3	10	Mineral oil	Excellent start, continues
117						11.5			Excellent start, continues
118						11.0			Excellent start, continues
119						10.8			Excellent start, continues
120						10.4			Excellent start, continues <sup>a</sup>
121					.200	12.0		JP-4 fuel	Light only, no start
122					.075	14.0			Light only, no start
123						17.0			Good start, continues
124					.200	14.0			Light, no start
125						15.0			Small light, no start
126					.075	16.0			Small light, no start
127						17.0			Good start, continues
128						14.0			Light, no start
129						16.0			Good start, continues
130						15.0			Light, no start
131						16.0			Light, no start
132						17.0			Light, no start
133					.200	16.0			Good start, continues
134					.075	17.5			Light, no start
135					.020	18.0			Light, no start
136					.20	22.3			Light, no start
137	1.87	.018	---	---	---	10.5		---	Minimum combustor-inlet total pressure for
138	3.75	.0114	---	---	---	13.5		---	ignition with an electric spark energy
139	6.0	.011	---	---	---	17.0		---	of 10 joules
140	3.75	.0114	---	---	---	16.5	-40	---	
141	1.87	.018	---	---	---	6.5		---	Minimum combustor-inlet total pressure
142	3.75	.0114	---	---	---	9.0		---	for steady-state burning
143	6.0	.011	---	---	---	13.0		---	
144	3.75	.0114	---	---	---	11.0	-46	---	Ref. 1

<sup>a</sup>Minimum exhaust pressure available.

TABLE III. - IGNITION DATA WITH ALUMINUM BOROHYDRIDE IN 48-INCH EXPERIMENTAL RAM-JET ENGINE

Run	Nominal air flow, lb/sec	Nominal air flow, lb $\frac{\text{lb}}{(\text{sec})(\text{sq ft})}$	Total pressure, in. Hg abs	Inlet temperature, °F	Calculated reference velocity, ft/sec	Fuel injector configuration	Quantity aluminum borohydride, cc	Observation
1	80	6.4	14.8	525	320	Pilot only	1.0	Good start
2	80	6.4	9.2	↓	514	Pilot only	1.0	(Exhaust nozzle open) light, no start
3	80	6.4	12.7		372	Pilot only	1.0	Lights pilot only
4	80	6.4	9.2	↓	514	Pilot + main	1.0	(Exhaust nozzle open) pilot lights and blows out
5	110	8.75	12.0	500	530	Pilot only	1.0	(Exhaust nozzle open) no light
6	110	8.75	14.8	↓	430	Pilot only	1.0	No light
7	80	6.4	15.6		296	Pilot only	1.0	(No ignition with spark) starts with hydride
8	80	6.4	14.1		323	Pilot only	2.0	Starts with hydride
9	80	6.4	11.03		419	Pilot only	1.0	No start
10	80	6.4	15.6	↓	296	Pilot only	2.0	Starts



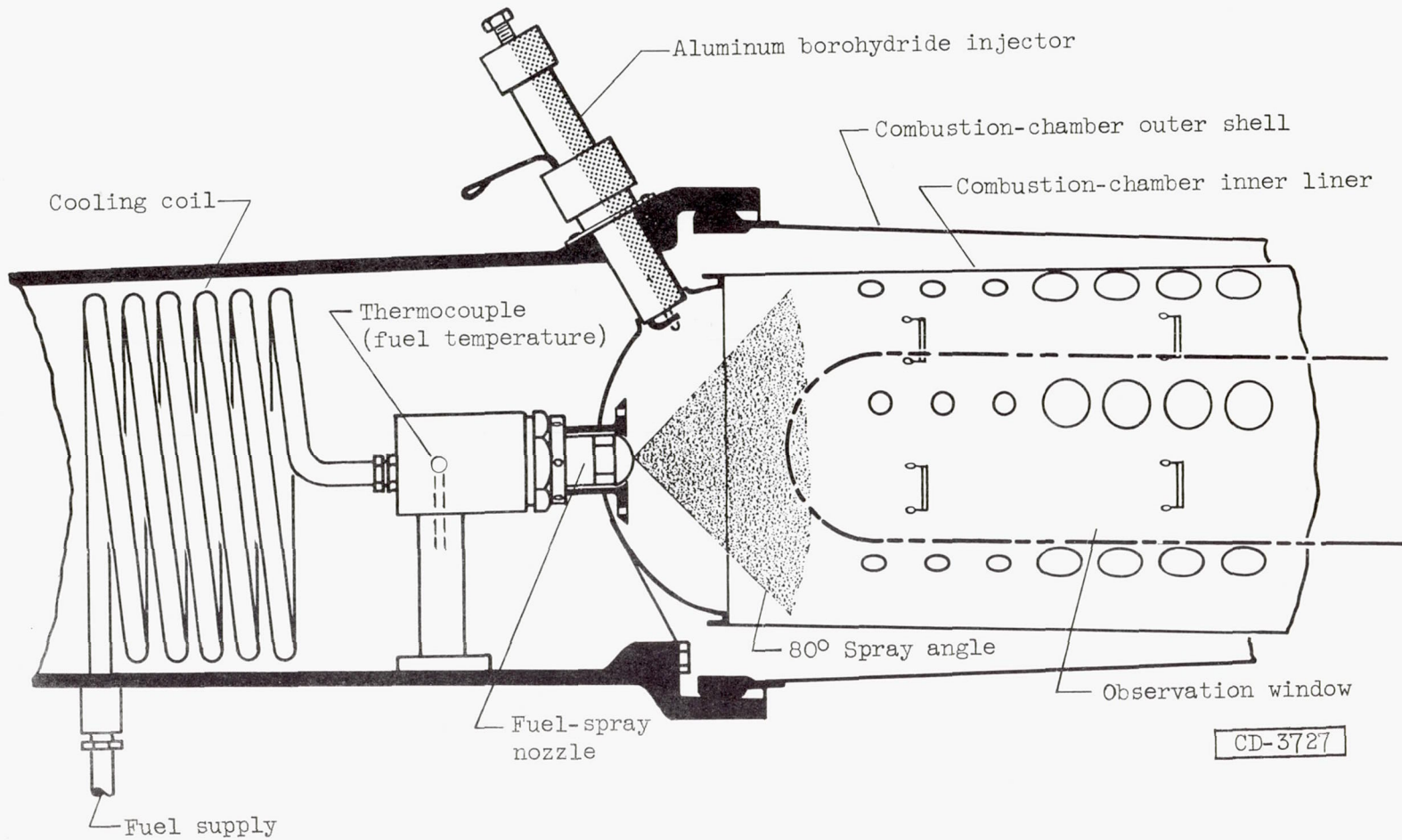

Figure 1. - Diagrammatic cross section of single tubular combustor.

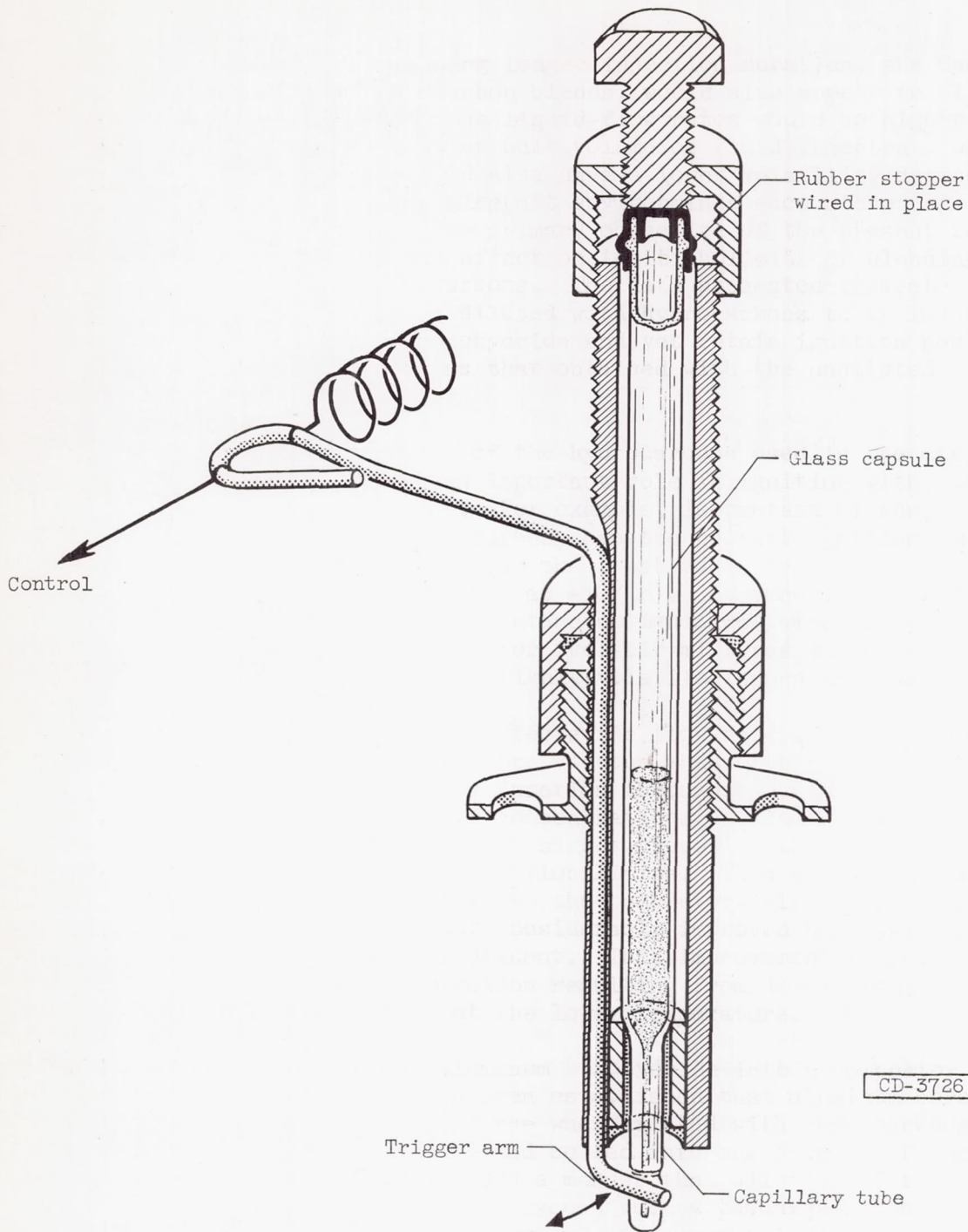

Figure 2. - Diagrammatic sketch of injector using pressurized glass capsules with capillary tube for single charges of chemical igniter.



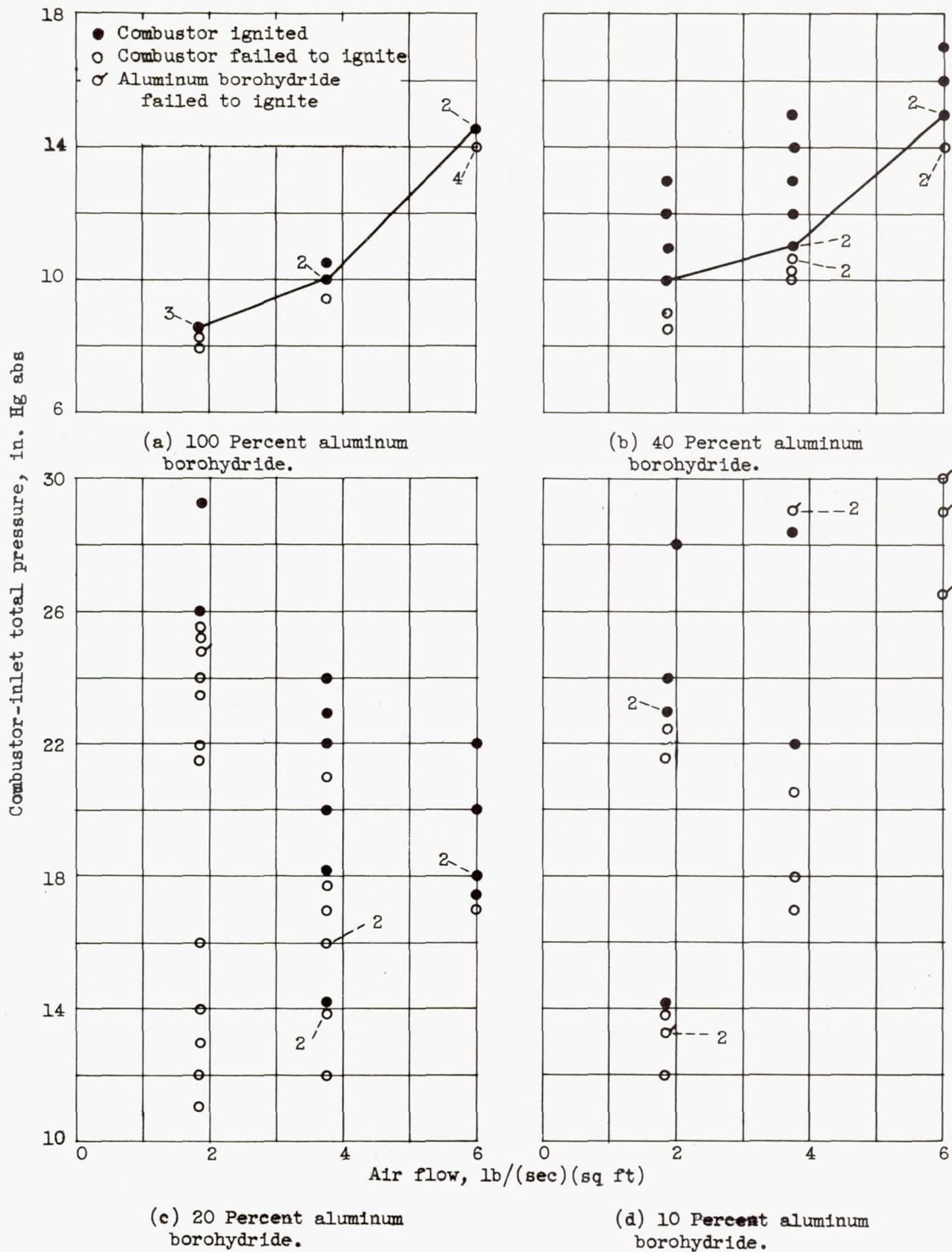

Figure 3. - Combustor ignition limits for various concentrations of aluminum borohydride. Diluent, JP-4 fuel; combustor-inlet air and fuel temperatures, 10° F.

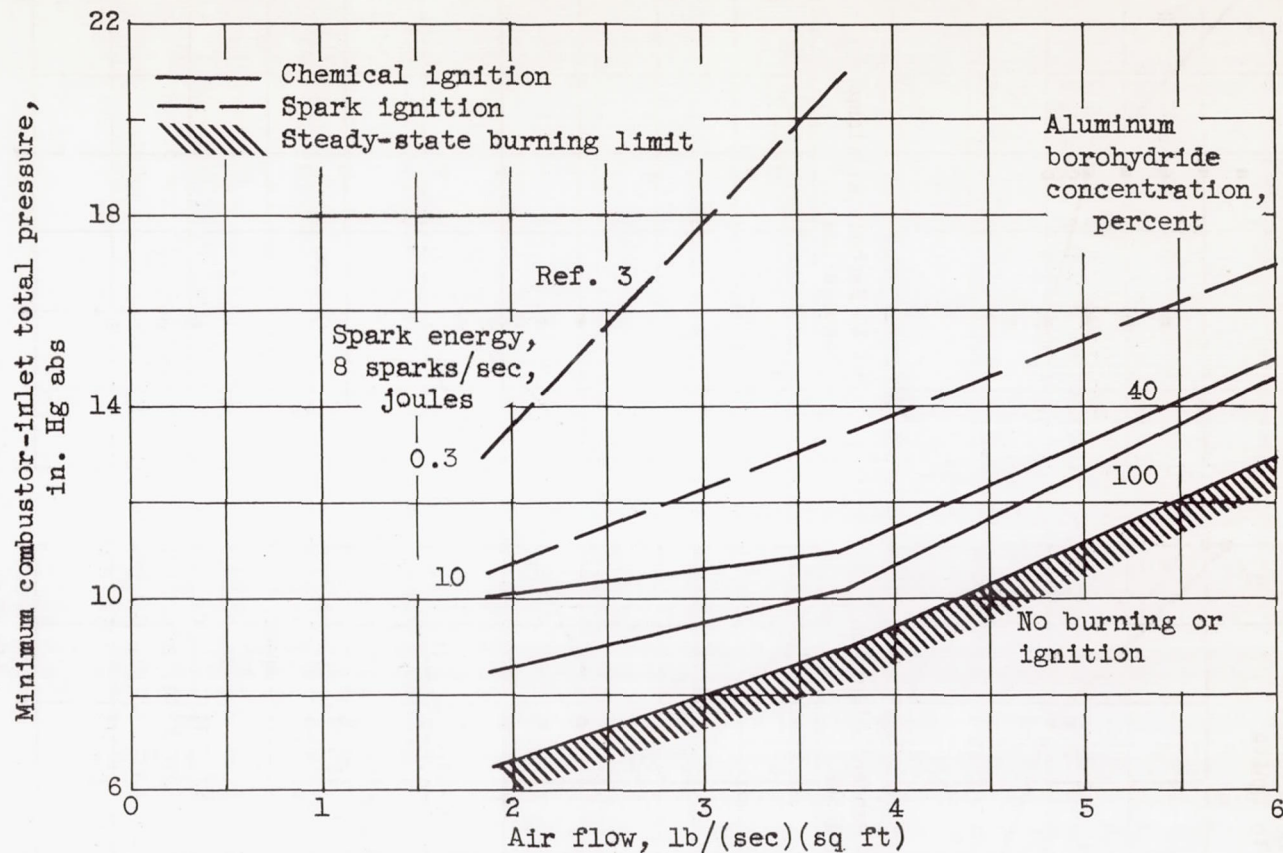

Figure 4. - Comparison of combustor burning limits with combustor ignition limits obtained with two concentrations of aluminum borohydride and with electric sparks as ignition sources. Diluent, JP-4 fuel; combustor-inlet air and fuel temperatures,  $10^{\circ}$  F; capillary tube diameter, 0.025 inch.



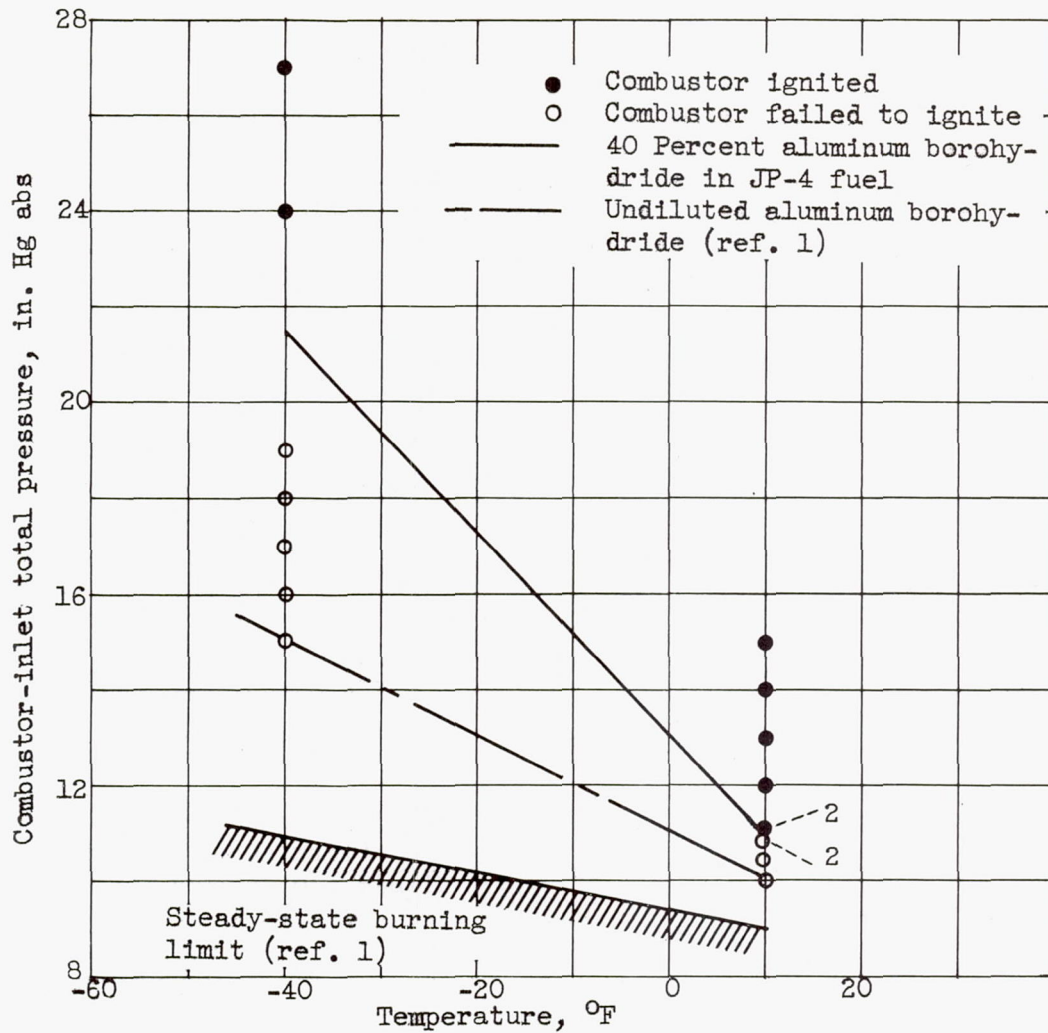

Figure 5. - Effect of inlet-air and -fuel temperatures on combustor ignition and burning limits. Aluminum borohydride concentration, 40 percent; air flow, 3.75 pounds per second per square foot; capillary tube diameter, 0.025 inch.

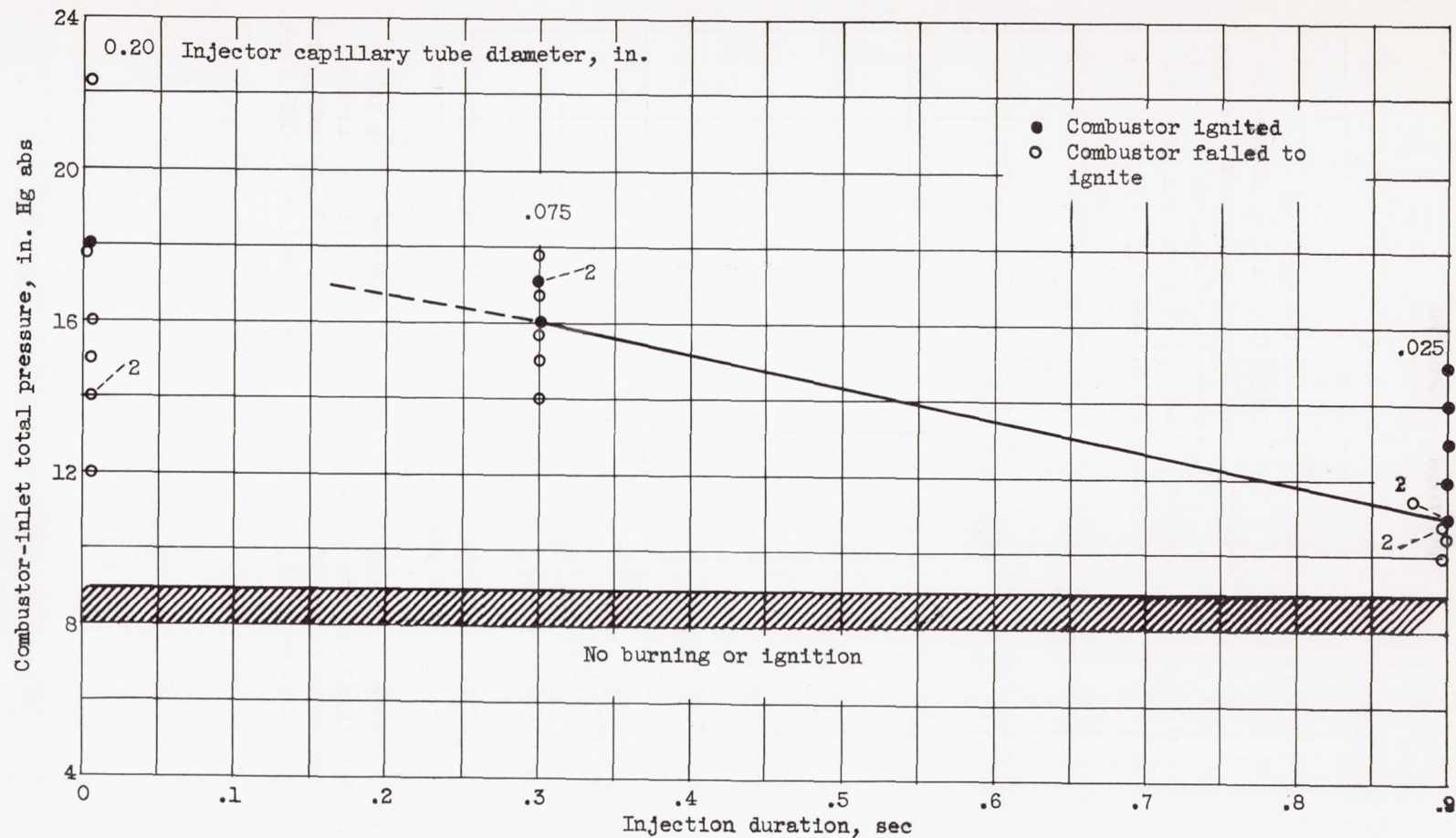

Figure 6. - Effect of injection duration on combustor ignition limits. Aluminum borohydride concentration, 40 percent; diluent, JP-4 fuel; inlet-air and -fuel temperatures, 10° F; air flow, 3.75 pounds per second per square foot; capillary length, 0.75 inch.



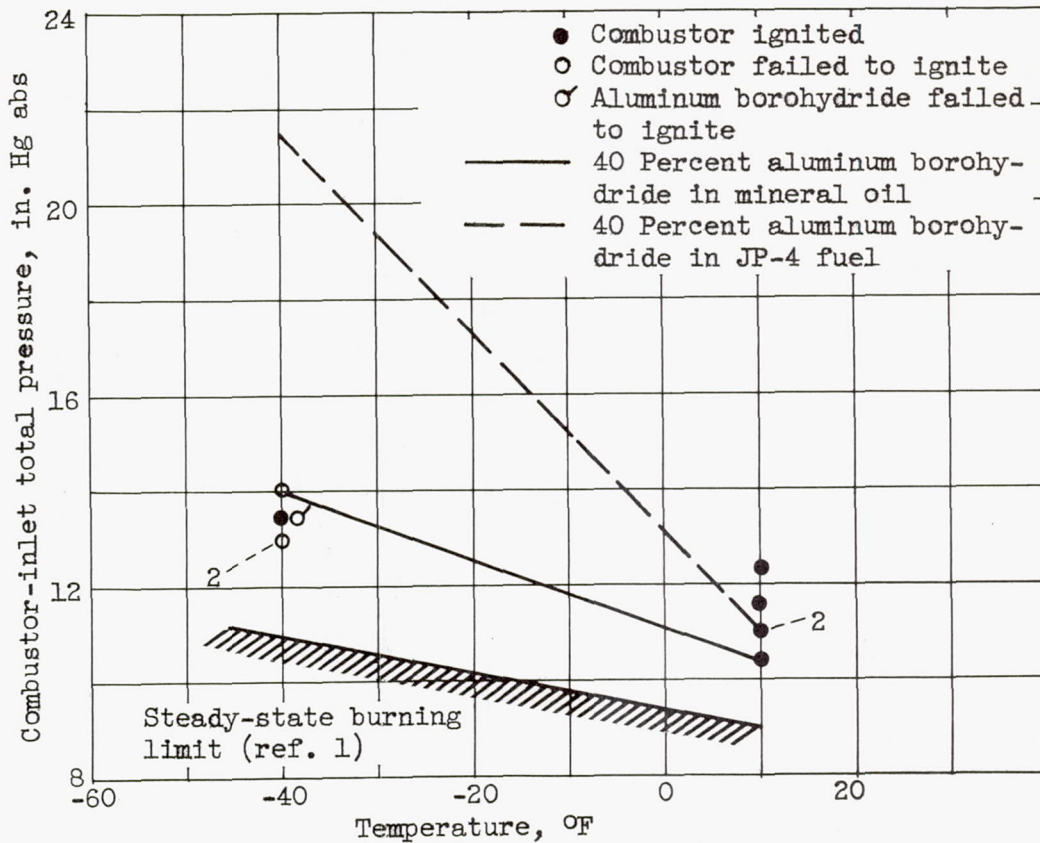

Figure 7. - Effect of diluent and inlet-air temperature on combustor ignition limits. Aluminum borohydride concentration, 40 percent; diluents, JP-4 fuel and mineral oil; air flow, 3.75 pounds per second per square foot; capillary tube diameter, 0.025 inch.

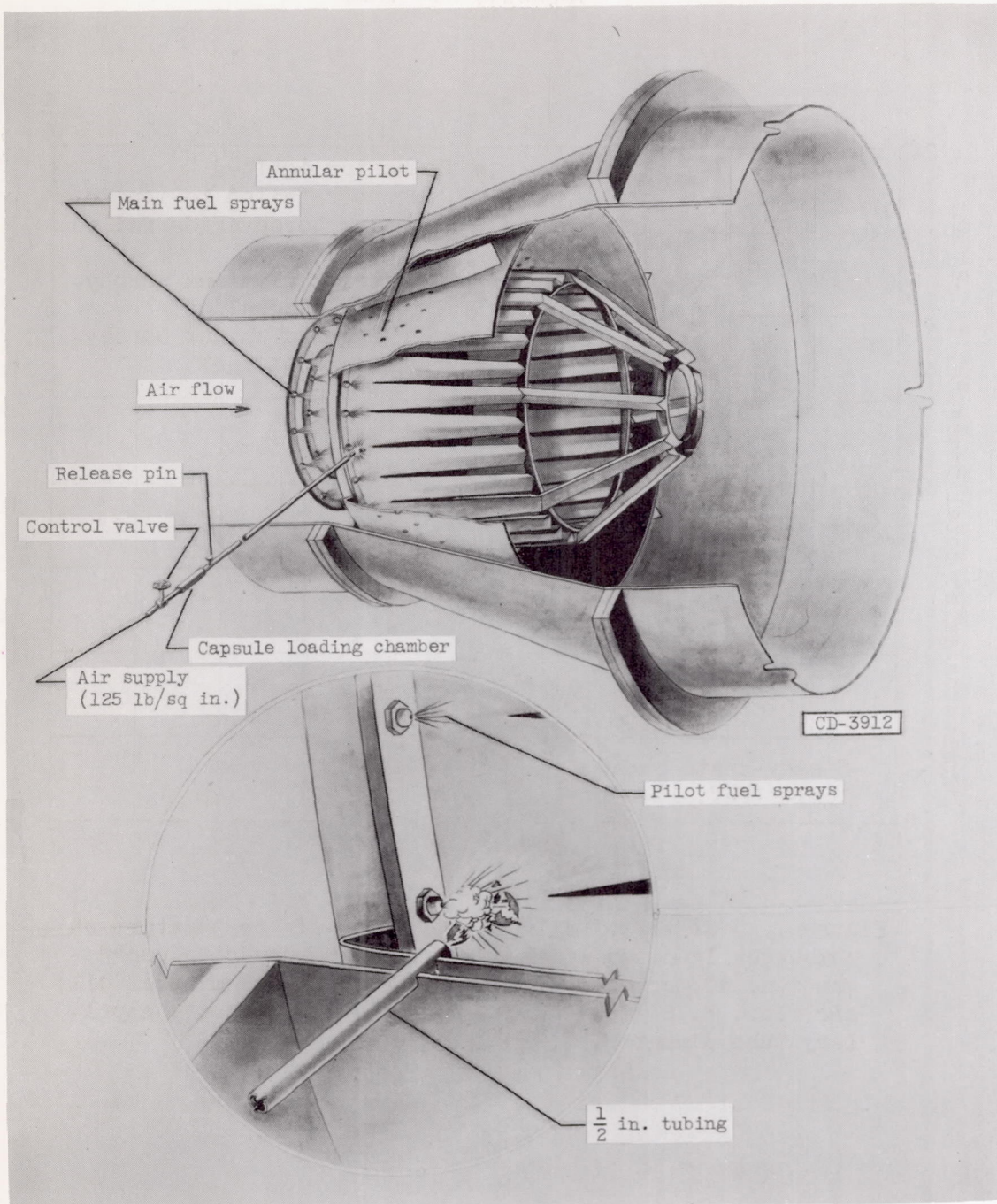

Figure 8. - Aluminum borohydride injection system for ignition in 48-inch ram-jet engine.



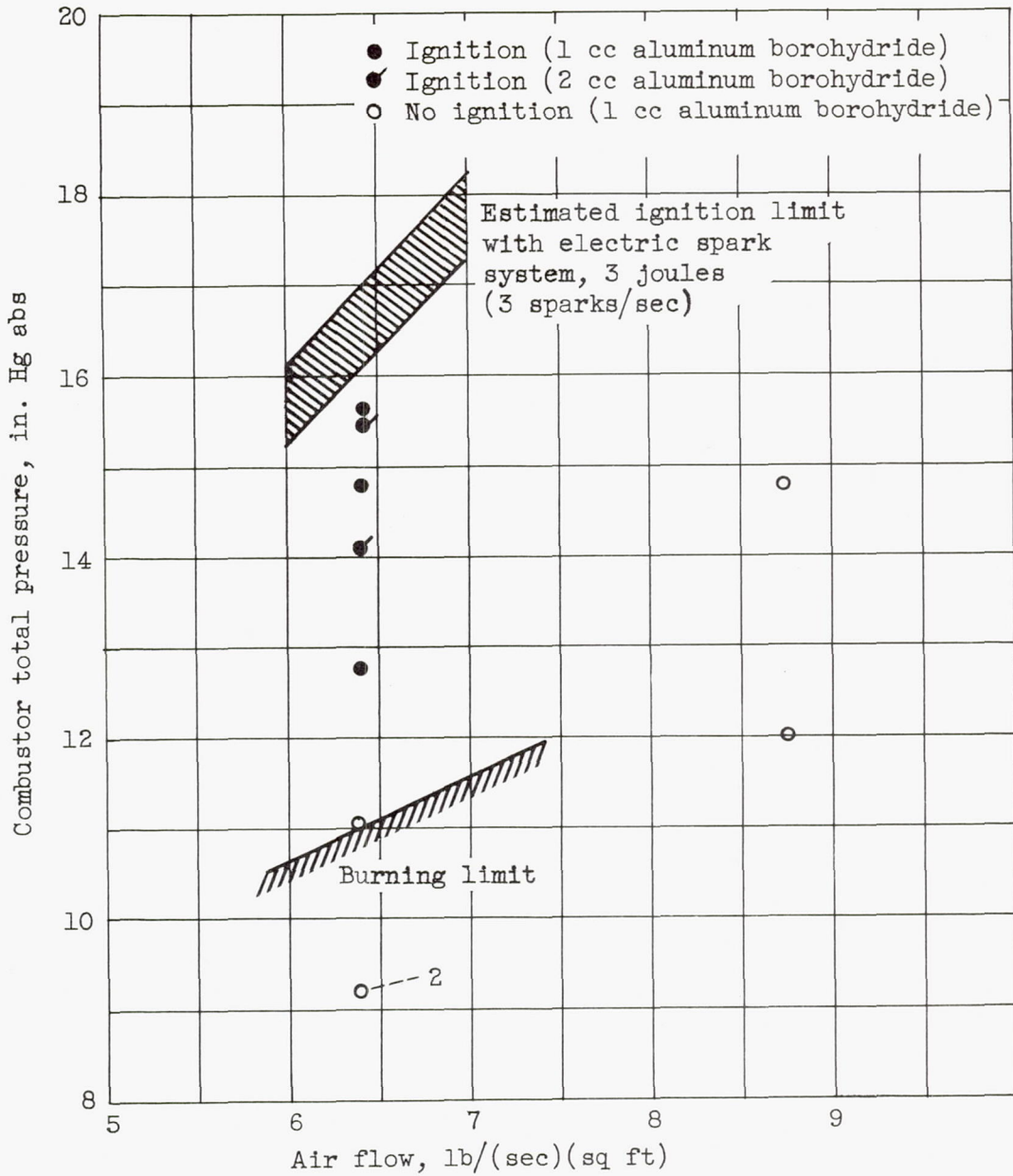

Figure 9. - Ignition data obtained in 48-inch ram-jet engine with aluminum borohydride as ignition source. Inlet-air temperature, 525° F (approx); fuel, JP-5.