

CASE FILE
COPY

RM E55B14

NACA RM E55B14

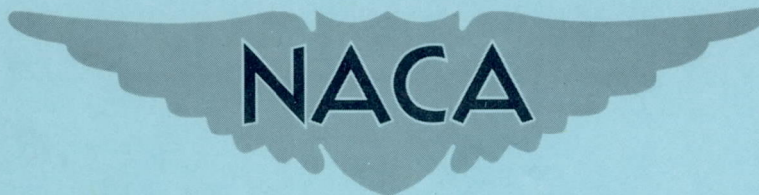

RESEARCH MEMORANDUM

NACA RESEARCH ON SLURRY FUELS THROUGH 1954

By Walter T. Olson and Roland Breitwieser

Lewis Flight Propulsion Laboratory
Cleveland, Ohio

NATIONAL ADVISORY COMMITTEE
FOR AERONAUTICS
WASHINGTON

April 21, 1955
Declassified June 20, 1957

NATIONAL ADVISORY COMMITTEE FOR AERONAUTICS

RESEARCH MEMORANDUM

NACA RESEARCH ON SLURRY FUELS THROUGH 1954¹

By Walter T. Olson and Roland Breitwieser

INTRODUCTION

The intention of this report is to review NACA research on slurry fuels through 1954.

Slurry fuels considered herein are suspensions of metals in hydrocarbons. For flight propulsion, metals as fuels offer the alternative possibilities of more flight range or more thrust than can be obtained with conventional hydrocarbons. They may also provide combustion under operating conditions where hydrocarbons will not burn. A discussion of metals and their compounds as fuels and a review of experimental work on them by the NACA and others up to 1952 are presented in reference 1. Reference 1 also considers the selection of particular fuels for research effort. The reasons for interest in certain metals as fuels are reviewed here with the aid of four figures:

Figure 1 presents the heating values of a few selected fuels relative to JP-4 fuel as one. Boron and pentaborane, typical of boron hydrides, have more heating value on a weight basis than JP-4. Magnesium, aluminum, boron, and pentaborane all have a greater heating value than JP-4 fuel on a volume basis, and again, all four of these fuels have a greater heating value on a per-pound-of-air-burned basis at stoichiometric combustion.

Heating values on a weight and volume basis are significant in long-range flight in that higher heating values make longer flight range possible (ref. 2). Heating value on a per-pound-of-air-burned basis is indicative of the amount of thrust that can be obtained from an engine of a given size. However, because much of the heat of combustion may be used to volatilize and dissociate the combustion products, the heating value on a per-pound-of-air basis cannot be used directly. The cross-hatched parts of the bars in figure 1 therefore indicate the relative net thrust that actually is achieved after correcting for the heat that goes into the exhaust products at stoichiometric combustion.

¹Presented orally to Office of Naval Research (Pasadena) and NACA Subcommittee on Combustion in December 1954.

Figure 2 is a plot of the air specific impulse against fuel specific impulse for a number of fuels (see also refs. 3 to 8). At fairly low values of thrust, hydrogen, boron hydrides, and boron all would require less fuel flow to maintain the thrust than would jet fuel, which is represented by octene-1.

Because aluminum, boron, and magnesium burn to higher temperatures and at higher over-all fuel-air ratios, they can give higher thrust per pound of air than is possible with the maximum obtained from jet fuel. Figure 2 (also ref. 7) makes it clear that boron is good for increased range; magnesium (and aluminum) do not give increased aircraft range, however.

Figure 3 shows the relative flight range calculated for a ram-jet powered missile at 60,000 feet, Mach 3.2, and following a Breguet flight path (ref. 2). The reason for interest in boron and boron hydrides is quite evident in this figure.

Figure 4 illustrates the advantages to be obtained from the high thrust possible with magnesium. A typical bomber was selected for illustrative purposes. With no thrust augmentation, the bomber did not take off even with many thousands of feet of runway. With 43-percent thrust augmentation from JP-4 fuel, the bomber takes off at 13,500 feet over a 10-foot obstacle. This distance is shortened to 10,700 feet at 67-percent thrust augmentation with a magnesium slurry. With 100-percent thrust augmentation with magnesium slurry and water injection combined, the take-off distance over a 10-foot obstacle is about 8000 feet.

These, then, are the reasons for interest in metals as aircraft fuels. Long flight range is achievable from boron, while high thrust for afterburners or for ram-jet engines can be obtained from aluminum, boron, or magnesium. Of course, development of superior liquid fuels, as discussed in reference 1, might replace metals for some, or even for all, of their possible applications.

The next question is how to use these metals in aircraft engines. NACA has done research on the combustion of metals as wires, briquettes, powders, pastes, and slurries. Experiments have included aluminum, boron, and magnesium. The simplest way to early application seemed to lie with slurries, which could be used in tanks and fuel-feed systems similar to those existing. Further, slurries could be pressure-sprayed into the combustion space.

Aluminum was very early dropped from the program in favor of magnesium because the sticky, molten aluminum oxides caused a very serious deposit problem in the combustor. Magnesium oxide does not melt appreciably at the flame temperatures encountered and does not stick to the combustor walls in the manner that aluminum oxide does.

This report will review highlights of research conducted through 1954 on slurry preparation and properties, combustion of boron slurries, and combustion of magnesium slurries. For brevity, apparatus, experimental methods, and precision and accuracy of data are not considered in detail; the original references should be consulted for details.

SLURRY PREPARATION AND PROPERTIES

The objective in slurry preparation has been to achieve a high metal concentration in a stable suspension that is still sufficiently fluid to be flowed, pumped, and sprayed. When large quantities of fine metal powders are shaken up with a carrier such as jet propulsion fuel, a muddy mass of wet metal powder results. Additives of the surface-active type permit these wet powders to flow and to be suspended uniformly in the carrier. It was learned very early that the quantities of material that could be suspended and the physical properties of the resulting suspension were functions of the particle size and shape, the composition of the carrying medium, and the type and concentration of any additives.

An empirical knowledge has been developed regarding the properties of slurries and what affects them. Much work remains to be done in this field. The next seven figures illustrate some of the high points of the lore that has been developed about slurry preparation and properties.

Settling Characteristics

Figure 5 illustrates the settling characteristics of magnesium particles of three different average particle sizes (ref. 9). The carrier was common to all samples of magnesium, and the particle shape was spherical in each case. The plot shows that the largest particle sizes settled the most and the most rapidly, while the smallest settled the least and more slowly. These data are typical of similar data with other carriers (e.g., ref. 10) and illustrate a rather general point, namely, the finer the particles being suspended, the more stable is the slurry.

Production of Fine Metal Particles

Consequently, a part of the problem of preparing stable slurries is to produce fine particle sizes. Conventional photomicrographs, the Fisher Sub-Sieve Sizer, and the Roller analyzer have been used to assay particle sizes. Photomicrographs reveal particle shapes. Dielectric properties of slurries have been studied as a means of learning particle shapes and extent of agglomeration (refs. 11 and 12).

Magnesium. - Figure 6 illustrates one way in which very small particles of magnesium may be prepared (ref. 13). The method involves shock-chilling magnesium vapor to produce very fine particles in a cloud. This cloud is washed down with excess JP fuel. The excess JP fuel is later removed to concentrate the slurry to the desired composition.

The figure shows a laboratory-size plant. A 4- by 9-inch pot was heated with an induction coil, and jet-propulsion fuel sprays chilled the vapor. Reduced pressure in the system lowered the temperatures at which magnesium vaporized. Helium flowed through the system to assist in sending magnesium vapor out of the vaporizing pot to the chilling section. Conventional centrifuges then concentrated the slurry.

Shape and size distribution of the particles prepared in this furnace are shown in figure 7; 50 percent by weight of the particles were smaller than about 1.5 microns.

Another method of producing fine magnesium particles is to pressure-spray molten magnesium metal into an inert atmosphere. Spherical particles result. Some grading of sizes can be done by cyclone separators. The bulk of the material is greater than 5 microns. Most of the NACA research on magnesium slurries has used material from this process.

Attempts to mill or grind magnesium particles, such as with ball mills or hammer mills, mainly result in flattening the particles without reducing their size appreciably. It has not been as easy to make flowable slurries of these particles as with the more spherical particles.

Boron. - The present commercial methods of producing boron by reducing the oxide with magnesium at high temperatures yield particles that assay as 1 to 2 microns in size. Nearly all the boron used in NACA programs is from this process.

Viscosity

Effect of additives on viscosity. - Slurries containing high concentrations of the finest particles that can be produced will not flow without surface-active agents. This point is illustrated in figure 8, in which the curves of viscosity against percent additive in the slurry are seen to rise sharply at zero concentration of additive (refs. 14 and 15). On the other hand, 1 or 2 percent of additive in these suspensions produced slurries with a viscosity on the order of glycerol or honey. Many different surface-active agents have been tried for this purpose. The most effective additives appear to be those with poly-functional active groups, additives such as G-672, glycerol sorbitan laurate, G-2854, or polyoxyethylene sorbitol tetroleate.

Relation of viscosity and settling. - While surface-active agents disperse the metal powder and make possible a fluid slurry, usually the more fluid the slurry, the more rapidly particles in it settle out. This statement is based on many observations, some of which are summarized in figure 9 (also refs. 15 to 17). In figure 9, the settling ratio (obtained the same way as it was in fig. 5) is plotted against time for different magnesium particle sizes in several media. It is seen that both 1.5-micron and 18-micron magnesium particles do not settle at all rapidly in very high-viscosity media, whereas both the 1.5- and the 13-micron particles settle quite rapidly and extensively in low-viscosity media. Thus, in general, the higher the viscosity, the less prone the slurry is to settle.

Effect of shear rate on viscosity. - If a slurry is made too viscous in an attempt to keep it from settling, however, it cannot be pumped, flowed, and sprayed. A fortunate characteristic of many of the slurries is that the viscosity decreases rapidly when they are pumped and flowed. The viscosity decreases with increase in shear rate. In other words, the slurries are usually not Newtonian liquids. The point is illustrated in figure 10 in which viscosity as measured with a Severs viscometer is plotted against the rate of shear in this instrument in reciprocal seconds (refs. 14 and 18). The Brookfield instrument measures viscosity at very low rates of shear, several orders of magnitude less than those obtained with the Severs instrument. It is seen that viscosities decreased with high rates of shear, particularly for those slurries that were made viscous with gelling agents such as aluminum octoate.

At high rates of shear, the viscosity change with shear is small enough that fuel can be metered over limited ranges of flow (ref. 10). In much of the research that has been done, the flow of slurries has been measured by displacing the slurry from a tank with regular JP-4 fuel, and in this case the JP-4 fuel, a Newtonian liquid, is metered.

Storage Life

One important consideration about the slurries that have thus far been discussed is that their storage life is definitely limited. Some of the high-viscosity slurries that are quite stable are made with gelling agents. These slurries have low viscosities at high rates of shear. They would appear to be a satisfactory solution to the problem of the contradictory features of stability and viscosity, except that the viscosity depreciates with time. Figure 11 shows the change in Brookfield viscosity with time for slurries made with aluminum octoate (refs. 14 and 18). When the Brookfield viscosity was as low as 1000 centipoises in the slurries shown in figure 11, the settling rate became sufficiently rapid that the slurries had reached the limit of their useful life. For example, the 50-percent

slurry made with 13-micron magnesium and 0.6 percent of aluminum octoate had a limited useful life of about 45 days.

Summary of Slurry Preparation and Properties

Thus, slurries can be made with high concentrations of metals of small particle size. These can be pumped, flowed, and sprayed, and have reasonable, if limited, storage life. The big liabilities in the art, thus far, are (1) uncertainty of the physical properties from batch to batch, (2) limited storage life, and (3) limited availability.

COMBUSTION OF BORON

Concurrently with work on the preparation and properties of slurry fuels, the combustion of boron slurries was studied. The questions that were asked were: Will boron burn, how does it burn, and, finally, what are the combustor design principles.

The experimental combustion studies were done in equipment from small-scale up to a scale suitable for the practical application of fuels. The type of equipment that was used for the initial evaluation of fuels is shown in figure 12 (also ref. 19). The fuel was introduced through a small orifice and atomized with air. The atomized fuel mixture entered a mixture preparation zone in which additional combustion air was added. The air was added through a wall made of porous wire cloth, which prevented the accumulation of solid particles in the mixture preparation zone. The flame was seated in the recirculation zone established by the sudden expansion to the 2-inch-outside-diameter tube. The mixture was ignited by a pilot flame which extended through a hole on the bottom of the burner. The hole was closed after ignition. The flow of combustion air was increased to the point where blow-out occurred. The test fuel was evaluated at several rates of fuel flow so that the blow-out velocity could be determined for various fuel-air ratios.

Typical boron-slurry data from the blow-out velocity apparatus (ref. 19) are shown in figure 13. Blow-out velocities are shown plotted against equivalence ratio and are compared with those of JP-4 fuel and propylene oxide. Propylene oxide is a convenient comparison fuel since it has roughly twice the laminar flame speed of JP-4. Two boron slurries were evaluated, differing only in the purity of the boron, 97 and 90 percent. As can be seen in figure 13, the blow-out velocities of the boron slurries are similar to those of JP-4 fuel.

A similar exploration of the combustion efficiency was conducted. Combustion efficiency was found by the analysis of the products of combustion. Figure 14 (also refs. 20 and 21) shows the apparatus used in

this study. The boron slurries were injected through a modified paint-spray gun. Additional secondary air was introduced, establishing a combustible mixture. The combustion products were then sampled at the combustor outlet. Solids were trapped in glass wool. The filtered products were collected in gas-sampling tubes.

Typical data (from ref. 21) obtained in this apparatus are shown in figure 15. Combustion efficiency data are shown for equivalence ratios of interest. The combustion efficiency was defined as 100 times the ratio of the oxidized fuel to the total fuel for each component. This definition was used for rich mixtures as well as lean.

The two slurries contained 30-percent boron by weight, but differed in the purity of the boron. The 86-percent-pure boron was made by a magnesium reduction process, and the 97-percent-pure boron was a product of an electrolysis process. The combustion efficiency of the boron in the high-purity boron slurry was roughly equivalent to that of the JP-4 fuel fraction, whereas the combustion efficiency for the lower-purity boron fraction was about 10 percentage points lower. In a gross sense, this apparatus indicated that the combustion characteristics of high-purity boron were comparable to those of JP-4 fuel.

The next step was to apply boron slurries to larger equipment. The apparatus used is shown in figure 16 (also ref. 22). Air was supplied through a choked diffuser into the combustion zone. The combustion-chamber length was varied between 40 and 52 inches; the combustor was terminated by a variable-area exhaust nozzle. A water spray quenched the exhaust gases immediately downstream of the exhaust nozzle. The temperature of the quenched gases was measured by thermocouples downstream. A heat balance across the system was made and combustion efficiency determined.

The can-type flame holders that were used in this program are shown in figure 17. Baffle-type flame holders were dropped early in the program because of poor combustion performance. The variations in the can flame holders include the usual combustor design variables such as blocked area, air-flow distribution, and combustion-chamber length. The flame holder which gave the best performance is the one located in the upper left-hand corner of figure 17. An interesting detail of this flame holder is the fuel-collecting shrouds located around the first band of holes. It was felt that these scoops or shrouds encouraged the recirculation of the boron component of the fuel into the upstream region of the flame holder.

A typical set of data from reference 22 obtained with this configuration is shown in figure 18 in which the heat output (Btu/lb of mixture) is plotted as a function of fuel-air ratio. Two 50-percent boron slurries (by weight) were evaluated; the slurries differed slightly in the amount of magnesium that is contained in the metal component of the fuel. The

suspended solids of one slurry was 90 percent boron, and the other was 86.5 percent boron and 12.5 percent magnesium; the remainders were undefined. The variation in composition resulted from different controls on the magnesium-reduction process used in making the boron fuel. Included on the curve are theoretical values for the maximum heat output of 50-percent boron slurry and pure JP-4 fuel.

The heat output for boron fuels did not approach that of the calculated values except near the stoichiometric fuel-air ratio, 0.0858. The highest combustion efficiency values observed were about 80 percent. The main observations that were made as a result of these and other data in the program were as follows: Heat outputs higher than the theoretical for JP-4 fuel were attained with boron fuels at high fuel-air ratios; a very high flame temperature was necessary for efficient combustion, as indicated by the high efficiencies only at near stoichiometric fuel-air ratio; scoops to encourage the recirculation of boron in the primary zone increased the efficiency; combustion-chamber-length variations between 40 and 52 inches had little influence on combustion efficiency; and small variations in fuel composition had little influence on combustion performance.

Since the primary application for boron slurries is in long-range ram-jet powered vehicles where it is desirable to operate at low temperature ratios, hence, low over-all fuel-air ratios, it was indicated that some type of flow stratification to produce a rich fuel mixture in the combustion chamber was necessary to achieve high combustion efficiencies.

The larger scale equipment shown in figure 19 (unpublished NACA data) was used to facilitate construction of combustors with a by-pass or stratified combustion zone. The fuel was fed from air-atomizing injectors. The fuel was kept inside a cylindrical sleeve which ensured fuel-air ratios that were near stoichiometric in the primary zone of the combustor even at over-all fuel-air ratios that were lean. The remainder of the air was by-passed around the fuel control sleeve and was mixed downstream of the primary zone. The details of the 16-inch-diameter engine resemble actual design layouts used in ram-jet engines. Combustion efficiency was measured by heat balance across the system.

One set of data that were obtained in this equipment is shown in figure 20 (unpublished NACA data). Combustion efficiency is plotted against equivalence ratio for two injector systems. The maximum combustion efficiency with the injectors with 0.25-inch fuel orifices was 75 percent at an equivalence ratio of 0.5. The use of smaller injectors, 0.116-inch orifice, increased the combustion efficiency to about 85 percent at an equivalence ratio of 0.4. The combustion efficiency for the boron slurries was consistently lower than that of JP-4 fuel evaluated at the same conditions.

Other problems found in the 16-inch-diameter engine tests with boron slurries are illustrated in figure 21. The high local temperature resulting from combustion at locally rich fuel-air ratios destroyed the can combustor. On the other hand, when the combustor parts were cooler, as with the sloping baffle system, large deposits of boron oxide resulted. Boron oxide virtually solidifies at temperatures of about 1000° F; reference 23 cites a viscosity of 1,000,000 centipoises for boron oxide at this temperature.

In summary, it can be seen that the complete story on how to design a flame holder for boron fuels has not been achieved. The high temperature required for high combustion efficiency destroyed engine parts. At lower combustor temperatures, deposition problems and low combustion efficiencies result. Some hope for improved combustor performance by better fuel atomization was indicated. It should be possible to build a combustor that uses a fuel-controlling sleeve to produce peak combustion efficiencies at the relatively lean fuel-air ratios desired for application to the long-range ram-jet missile.

MAGNESIUM COMBUSTION

Paradoxically, magnesium, although plentiful, has not been plentiful in small particle sizes suitable for slurry fuels. As a consequence, only limited combustion work has been accomplished.

Basic Combustion Experiments

Some idea of the combustion characteristics of magnesium slurries can be had from measurements of blow-out velocity in the apparatus already described (fig. 12). The slurry was well mixed with air ahead of the 2-inch burner section. Blow-out velocity was determined for different fuel-air ratios.

Typical data are presented in figure 22 (also refs. 19 and 24). JP-4 fuel with a flame speed like that of most hydrocarbons, 35 centimeters per second, and propylene oxide with almost twice this flame speed, are shown on the curve for reference. The very fine powder magnesium slurries, that is, the 1.5-micron and the furnace material, which is a somewhat smaller particle size still, burned at much leaner equivalence ratios than would JP-4 fuel or 15-micron magnesium slurry, or propylene oxide. Flame from these slurries could not be blown out by velocities within the limits of the apparatus. Other work in a somewhat similar apparatus showed more efficient combustion of 4.5-micron magnesium slurries than 20-micron magnesium slurries (ref. 20).

Basic combustion data for magnesium have been obtained by experimentally observing the burning times for magnesium ribbons (ref. 25) in various mixtures of oxygen in argon, nitrogen, and helium. Some of the experiments were conducted with various percentages of water in argon-oxygen mixtures. The burning times of magnesium ribbons of 0.015-by-0.31-centimeter cross section decreased by a factor of approximately 10 with increasing oxygen concentration over the range 17 to 100 percent by volume. The times were slightly longer with argon mixtures than with nitrogen mixtures and were much shorter with helium mixtures. Increasing the moisture content shortened the burning time somewhat.

Photographs showed that the magnesium ribbon vaporized as it burned. Consequently, burning times were calculated from a heat- and mass-transfer mechanism quite analogous to that used for calculating the burning times of liquid fuel drops. An important difference was that the concept of an infinitesimally thin flame front used for liquid-fuel drops was not used. Instead, the magnesium ribbon was assumed to burn in a high-temperature reaction zone of finite thickness. Excellent qualitative agreement between experiment and calculation was achieved; also, actual numerical values agreed within a factor of 2 to 3.

Magnesium slurries burn much more rapidly than boron slurries, because the difference between the flame temperature and the boiling point of magnesium is much larger than that of boron. Thus, a larger temperature gradient for heat and mass transfer exists for magnesium as it burns than for boron as it burns.

Combustion in Afterburners

A 6-inch-diameter afterburner-type combustor was operated on magnesium slurry. The small size of this afterburner was set by the limited quantities of magnesium slurry fuels available. The apparatus is shown in figure 23 (also ref. 26). A single turbojet combustor provided gases of temperature and composition that would enter a full-scale afterburner. Total thrust was measured at the thrust barrel.

Two fuel-injector and flame-holder combinations are shown in figure 23. Magnesium slurry was injected from eight radial stations located exactly at the downstream edge of a single V-gutter that spanned the 6-inch test section. When magnesium slurry was injected upstream of the V-gutter, it burned the V-gutter out. Fuel for JP-3 experiments was injected from a spray bar located 11 inches upstream of the V-gutter. When JP-3 fuel was injected at the plane of the V-gutter, it would not burn satisfactorily.

Typical data from the apparatus of figure 23 are shown in figure 24. Net thrust of the 6-inch afterburner is plotted against equivalence ratio

for the various fuels shown. JP-3 was injected upstream; it operated over the range shown. All the other data were obtained with the injection at the flame-holder station. High-concentration slurries burned over much wider ranges than did JP-3 fuel. Furthermore, a higher thrust, predicted thermodynamically, was obtained with magnesium.

If water injection in the turbojet engine were combined with afterburning, the engine should get the combined thrust augmentation of both systems. However, the experience is that water injection, particularly at high water-flow rates, adversely affects the combustion efficiency in the afterburner when it is burning conventional jet fuels. The effectiveness of the combined system is reduced. High water-flow rates may even extinguish the afterburner flame. Because of this problem, the effects of water on the combustion of JP-3 and on the combustion of magnesium slurry were determined in the rig shown in figure 23. Typical data appear in figure 25 (also ref. 27).

At high water-air ratios, the temperature at the end of the afterburner decreased with both JP-3 fuel and with the 60-percent magnesium slurry because of the high dilution with water. Further analysis of the data, however, shows that the combustion efficiency of the JP-3 fuel was much reduced at water-air ratios above 0.04, while the combustion efficiency of 60-percent magnesium slurry was essentially unaffected. Unlike hydrocarbons, magnesium slurry burned quite vigorously and at high combustion efficiencies in the small afterburner even at high water-flow rates.

Thrust augmentation data are summarized in figure 26. Some of the data show the thrust augmentation obtained in a full-scale engine with water injection alone (ref. 28). About 22-percent augmentation was achieved at a liquid ratio of about 7, that is, seven times the normal fuel-flow rate of the engine with no thrust augmentation. Another curve shows 43-percent thrust augmentation by afterburning with about three times the fuel flow of the unaugmented engine. With water injection combined with this afterburner, additional augmentation was obtained to about 70 percent (ref. 29). At higher water-flow rates, unstable operation was encountered and the combustion efficiency of the afterburner dropped so rapidly that no further thrust augmentation was obtained.

The dashed curve on figure 26 represents data from the 6-inch apparatus plotted on the same basis as the data for the full-scale engines (ref. 27). These data show nearly 70-percent thrust augmentation with magnesium afterburning alone; fuel flow was seven times that with no augmentation. Water injection combined with afterburning with magnesium slurry doubled the unaugmented thrust at a liquid ratio of 14.

One very short duration run of magnesium slurry in a full-scale afterburner has been made. The data point for this run with no water injection and with stoichiometric combustion is plotted on figure 26 and agrees quite closely with the results from the 6-inch-diameter apparatus.

There is little doubt that magnesium combustion offers promise of the high thrust augmentation so fervently desired by the aircraft industry, although liquid consumption rates are high. Wall cooling and fuel handling are big problems still outstanding, and there will be times when the oxide exhausts will be objectionable.

Ram-Jet Combustor

The application of magnesium slurries to ram-jet engines closely parallels the afterburner application. High reactivity, high thrust potential, and the high impulse characteristics per unit volume of magnesium slurries make it suitable for short-range ram-jet vehicles.

The reasons for the ram-jet program were twofold. First, an aerodynamic test vehicle used at the Langley laboratory was limited in performance because it used ethylene fuel in its two, small ram-jet engines. Ethylene, which has a high flame speed, was used in order to achieve high efficiencies in the short, small-diameter engines; however, on the basis of reactivity, thrust, and volume characteristics, the magnesium slurry seemed to be a better choice. Second, it was expected that extension of the magnesium-slurry fuel research to a flight application would uncover difficulties that might otherwise have been missed.

The particular engine used for developing a combustor for flight is shown in figure 27. The combustor was 6.5 inches in diameter and 19 inches long. A deflector plate added to the baffle-type flame holder deflected the magnesium component of the fuel into the piloting region.

Typical data achieved in this configuration are shown in figure 28, a plot of propulsive thrust coefficient as a function of equivalence ratio. The theoretical curves are for a 50-percent magnesium slurry in JP-3 fuel and for a typical hydrocarbon fuel such as JP-3 and JP-4. The actual data from the connected-pipe tests (ref. 30) closely match the theoretical values at the higher equivalence ratios. The actual performance data of the hydrocarbon fuel, in this case ethylene, did not approach the theoretical values as closely. More recent work dealing with engine starting and free-jet performance is presented in reference 31.

Flight Test of Magnesium Slurries

The development and flight evaluation of the twin-engine test vehicle were preceded by flight tests of a low-cost single-engine test vehicle. It was rocket boosted. The flight data were obtained by radar.

The single-engine vehicle was similar to the engine shown in figure 27 except that the diffuser was lengthened to house 14 pounds of magnesium

slurry. The 50-percent magnesium slurry was expelled by a solid propellant gas generator located at the upstream end of the fuel charge.

The results of the first successful flight can be briefly summarized as follows: rocket boost to 1.75 Mach number and altitude of 6380 feet; successful ram-jet take-over; maximum ram-jet acceleration, 4.6 g; air specific impulse, 151 seconds; maximum Mach number, 3.48; and maximum gross thrust coefficient, 0.658.

CONCLUSIONS

The following conclusions were made from the data reviewed:

1. Research on metals as fuels has concentrated on boron for long-range flight and on magnesium for high thrust. Other metals, although thermodynamically competitive with these, have been shelved for one reason or another in current NACA research.
2. Metals as small particles have been made into high-concentration slurries that are reasonably stable and fluid. The physical properties are far from perfect for aircraft.
3. Combustion of boron is not at all satisfactory at present. There are still a few research leads to be tried, however.
4. Combustion of magnesium shows excellent promise. Not only has the high thrust been realized, but also, magnesium provides a bonus in that it burns well under circumstances where hydrocarbons burn only with difficulty.
5. The art of burning metals as fuels for aircraft engines is now emerging from small-scale research to research in combustors and engines of practical size. Continuing problems are production, storing, handling, fuel systems, combustor design, and cooling. Plans for future effort should consider the status of development of other fuels that conceivably might replace either boron, or magnesium, or even both.

Lewis Flight Propulsion Laboratory
National Advisory Committee for Aeronautics
Cleveland, Ohio, February 15, 1955

REFERENCES

1. Olson, Walter T., and Gibbons, Louis C.: Status of Combustion Research on High-Energy Fuels for Ram Jets. NACA RM E51D23, 1951.
2. Henneberry, Hugh M.: Effect of Fuel Density and Heating Value on Ram-Jet Airplane Range. NACA RM E51L21, 1952.
3. Gammon, Benson E.: Preliminary Evaluation of the Air and Fuel Specific-Impulse Characteristics of Several Potential Ram-Jet Fuels. I - Octene-1, Aluminum, and Aluminum - Octene-1 Slurries. NACA RM E51C12, 1951.
4. Gammon, Benson E.: Preliminary Evaluation of the Air and Fuel Specific-Impulse Characteristics of Several Potential Ram-Jet Fuels. II - Magnesium, and Magnesium - Octene-1 Slurries. NACA RM E51C23, 1951.
5. Gammon, Benson E.: Preliminary Evaluation of the Air and Fuel Specific-Impulse Characteristics of Several Potential Ram-Jet Fuels. III - Diborane, Pentaborane, Boron, and Boron - Octene-1 Slurries. NACA RM E51D25, 1951.
6. Gammon, Benson E.: Preliminary Evaluation of the Air and Fuel Specific-Impulse Characteristics of Several Potential Ram-Jet Fuels. IV - Hydrogen, α -Methylnaphthalene, and Carbon. NACA RM E51F05, 1951.
7. Breitwieser, Roland, Gordon, Sanford, and Gammon, Benson: Summary Report on Analytical Evaluation of Air and Fuel Specific-Impulse Characteristics of Several Nonhydrocarbon Jet-Engine Fuels. NACA RM E52L08, 1953.
8. Tower, Leonard K., and Gammon, Benson E.: Analytical Evaluation of Effect of Equivalence Ratio, Inlet-Air Temperature, and Combustion Pressure on Performance of Several Possible Ram-Jet Fuels. NACA RM E53G14, 1953.
9. Lamberti, Joseph M.: The Effect of Magnesium Particles of Various Equivalent Diameters on Some Physical Properties of Petrolatum-Stabilized Magnesium-Hydrocarbon Slurries. NACA RM E54A22, 1954.
10. Gibbs, James B., and Cook, Preston N., Jr.: Preparation and Physical Properties of Metal Slurry Fuels. NACA RM E52A23, 1952.
11. Altshuller, Aubrey P.: The Shapes of Particles from Dielectric Constant Studies of Suspensions. Jour. Phys. Chem., vol. 58, 1954, p. 544.

12. Altshuller, Aubrey P.: Study of Some Dielectric Properties of Suspensions of Magnesium Particles in Mineral Oil. NACA RM E53L09, 1954.
13. Witzke, Walter R., Prok, George M., and Walsh, Thomas J.: A Preliminary Study of the Preparation of Slurry Fuels from Vaporized Magnesium. NACA RM E53K23, 1954.
14. Goodman, Irving A., and Fenn, Virginia O.: Preparation and Properties of Concentrated Boron-Hydrocarbon Slurry Fuels. NACA RM E54F18a, 1954.
15. Pinns, Murray L.: Effect of Surface Active Additives on the Physical Behavior of 50-Percent Slurries of 1.5-Micron Magnesium in n-Decane. NACA RM E54K22a, 1955.
16. Cook, Preston N., Jr., Evans, Vernida E., and Lezberg, Erwin A.: Experimental Investigation of Physical and Combustion Properties of Several Residual Fuel Oils and Magnesium - Fuel-Oil Slurries in a Ram-Jet-Type Combustor. NACA RM E53D30, 1953.
17. Pinns, Murray L., and Goodman, Irving A.: Study of the Physical Properties of Petrolatum-Stabilized Magnesium-Hydrocarbon Slurry Fuels. NACA RM E53J16, 1954.
18. Caves, Robert M.: Stabilization of 50-Percent Magnesium - JP-4 Slurries with Some Aluminum Soaps of C₈ Acids. NACA RM E54C10, 1954.
19. Cook, Preston N., Jr., Lord, Albert M., and Kaye, Samuel: Blow-Out Velocities of Various Petroleum, Slurry, and Hydride Fuels in a $\frac{7}{8}$ -Inch Diameter Combustor. NACA RM E54A28, 1954.
20. Lord, Albert M., and Evans, Vernida E.: Effect of Particle Size and Stabilizing Additives on the Combustion Properties of Magnesium Slurry. NACA RM E52K12, 1953.
21. Lord, Albert M.: An Experimental Investigation of the Combustion Properties of a Hydrocarbon Fuel and Several Magnesium and Boron Slurries. NACA RM E52B01, 1952.
22. Reynolds, Thaine W., and Haas, Donald P.: Performance of Slurries of 50 Percent Boron in JP-4 Fuel in 5-Inch Ram-Jet Burner. NACA RM E54D07, 1954.
23. Rabinovich, B. V.: Viscosity of Borox and Boric Anhydride in the Interval of Softening. Jour. Phys. Chem. (U.S.S.R.), vol. 16, 1942, pp. 23-26.

24. Morris, James F., Caves, Robert M., and Lord, Albert M.: Blow-Out Velocities of Several Slurry and Liquid Fuels in a $1\frac{7}{8}$ -Inch-Diameter Combustor. NACA RM E54L27a, 1955.
25. Coffin, Kenneth P.: Burning Times of Magnesium Ribbon in Various Atmospheres. NACA TN 3332, 1954.
26. Tower, Leonard K., and Branstetter, J. Robert: Combustion Performance Evaluation of Magnesium-Hydrocarbon Slurry Blends in a Simulated Tail-Pipe Burner. NACA RM E51C26, 1951.
27. Tower, Leonard K.; Effect of Water Vapor on Combustion of Magnesium-Hydrocarbon Slurry Fuels in Small-Scale Afterburner. NACA RM E52H25, 1952.
28. Povolny, John H., Useller, James W., and Chelko, Louis J.: Experimental Investigation of Thrust Augmentation of 4000-Pound-Thrust Axial-Flow-Type Turbojet Engine by Interstage Injection of Water-Alcohol Mixtures in Compressor. NACA RM E9K30, 1950.
29. Useller, James W., and Povolny, John H.: Experimental Investigation of Turbojet-Engine Thrust Augmentation by Combined Compressor Coolant Injection and Tail-Pipe Burning. NACA RM E51H16, 1951.
30. Branstetter, J. Robert, Gibbs, James B., and Kaufman, Warner B.: Magnesium-Slurry Combustion Performance in 6.5-Inch-Diameter Ram-Jet Engine Mounted in Connected-Pipe Facility. NACA RM E53E27, 1953.
31. Gibbs, James B.: Starting Characteristics and Combustion Performance of Magnesium Slurry in 6.5-Inch-Diameter Ram-Jet Engine Mounted in Connected-Pipe Facility. NACA RM E53K05, 1954.

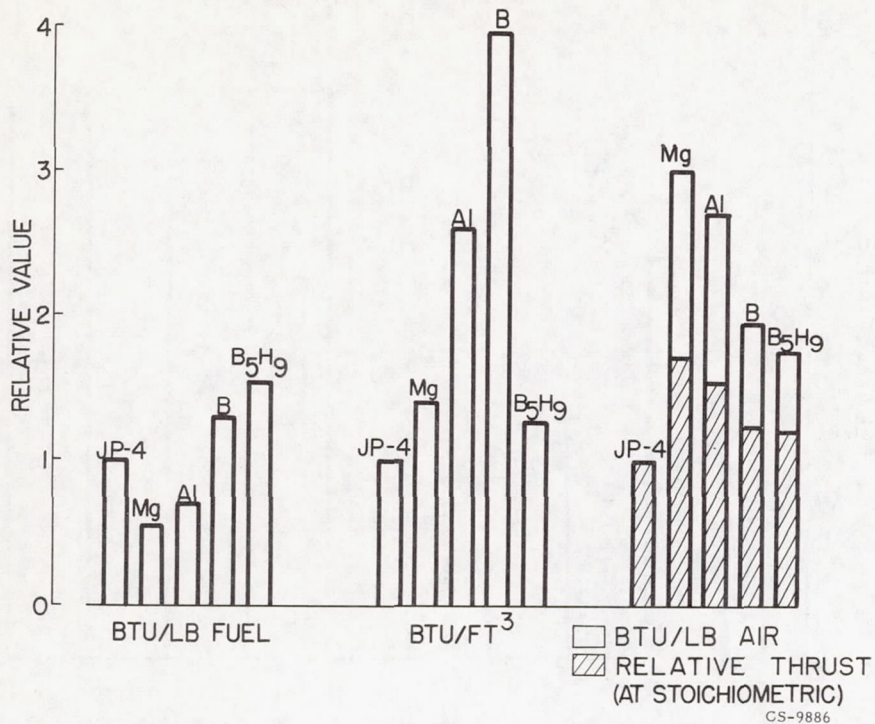

Figure 1. - Relative heating values.

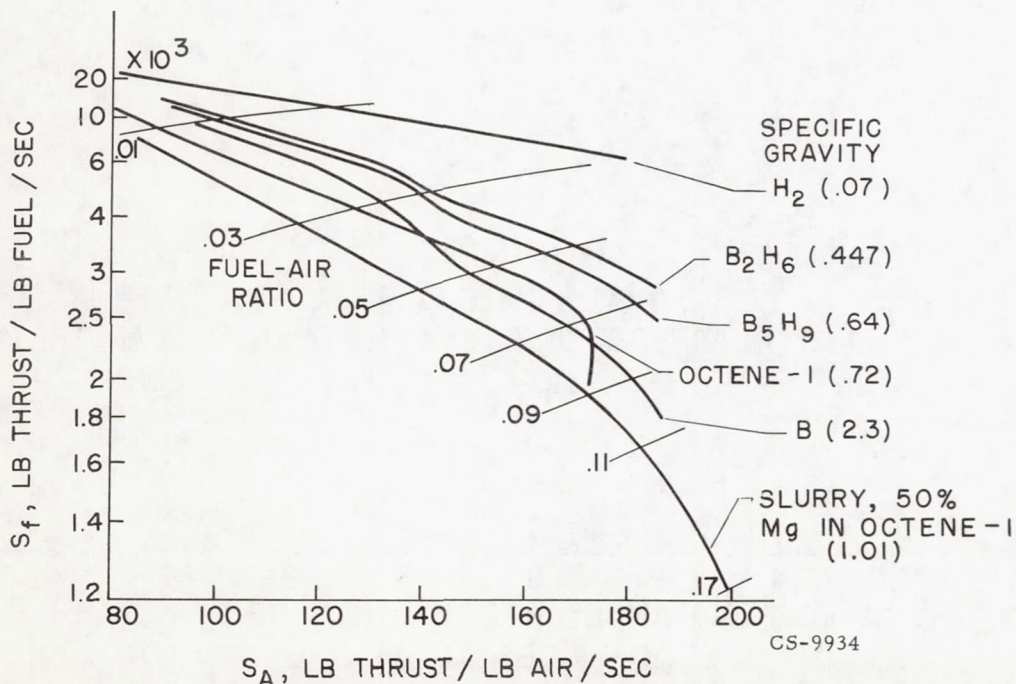

Figure 2. - Impulse characteristics of jet engine fuels.

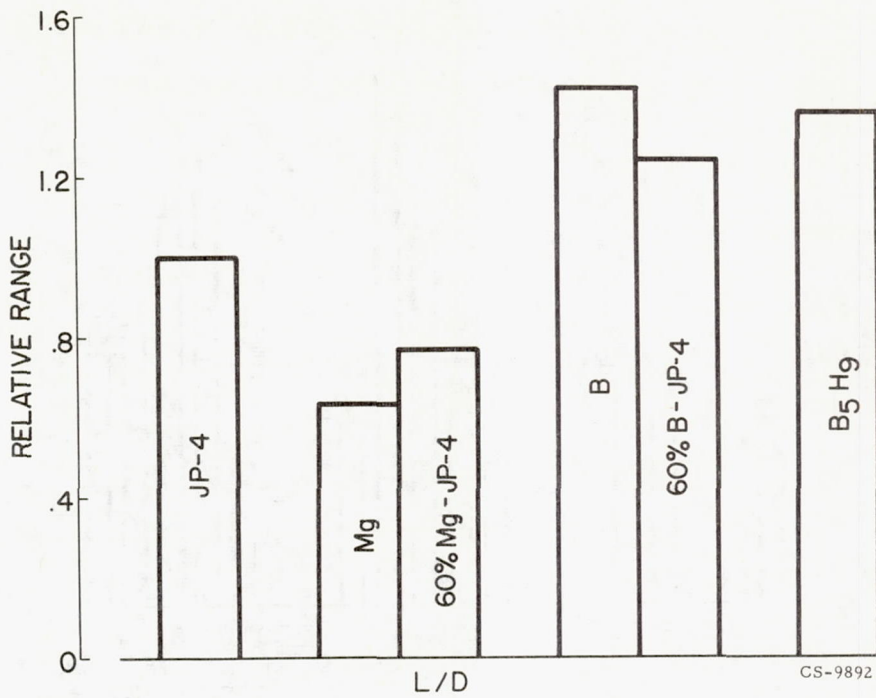

Figure 3. - Relative range of ram-jet missile. Initial altitude, 60,000 ft; free-stream Mach number, 3.2.

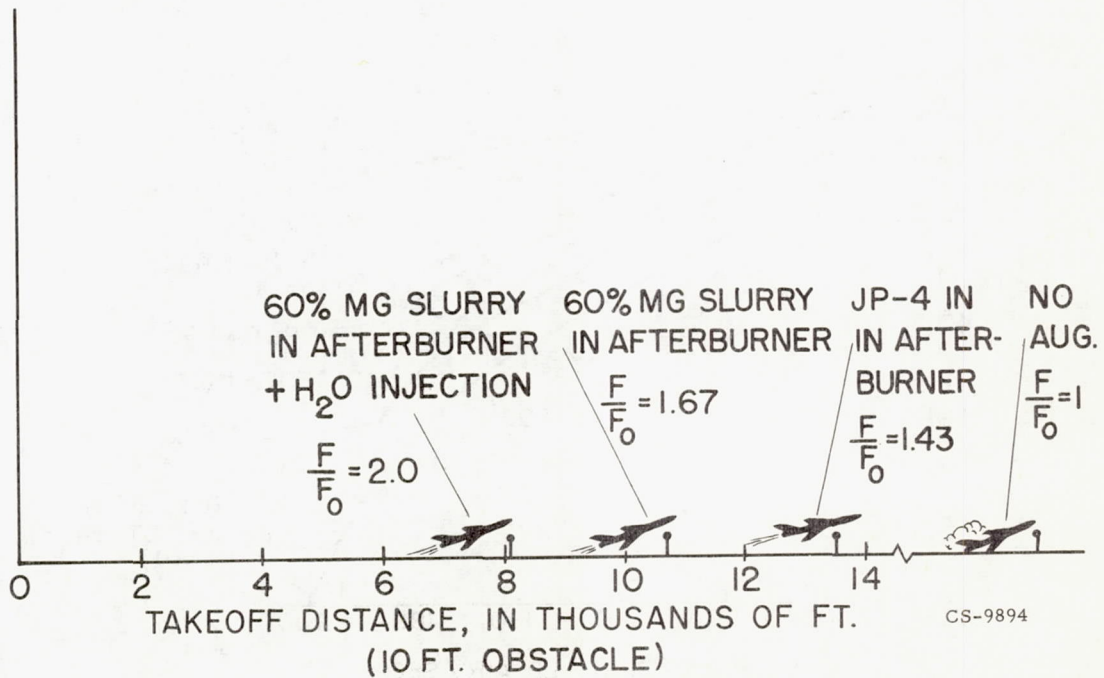

Figure 4. - Take-off characteristics of a turbojet bomber. F , augmented thrust; F_0 , unaugmented thrust.

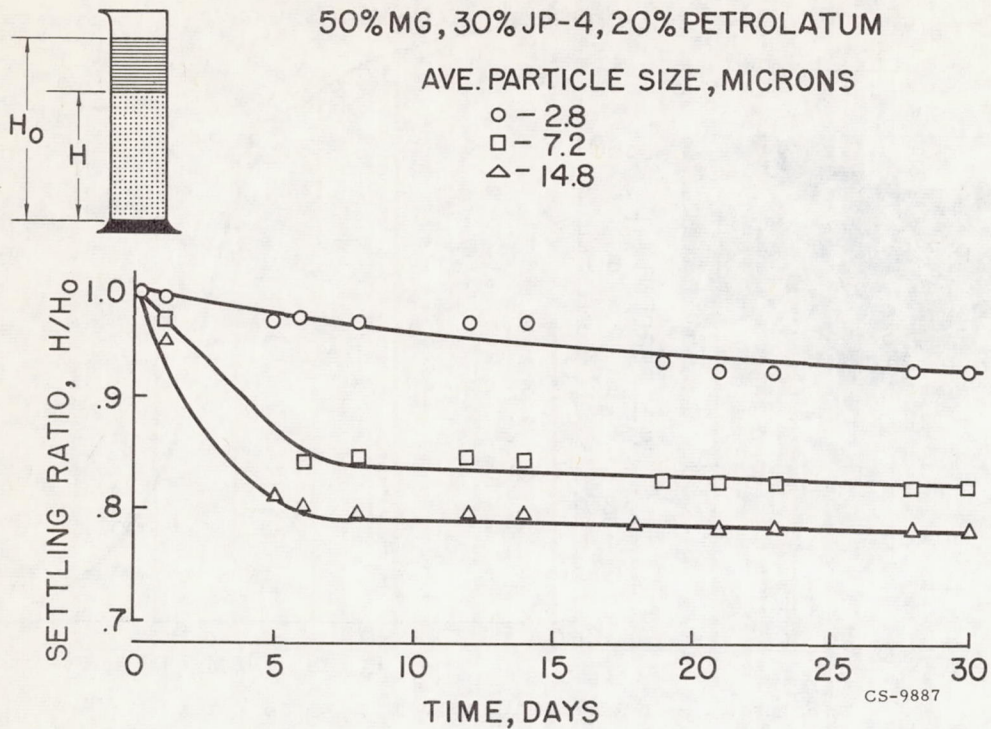

Figure 5. - Settling characteristics of magnesium particles. H, height of column of settled particles; H_0 , height of liquid column.

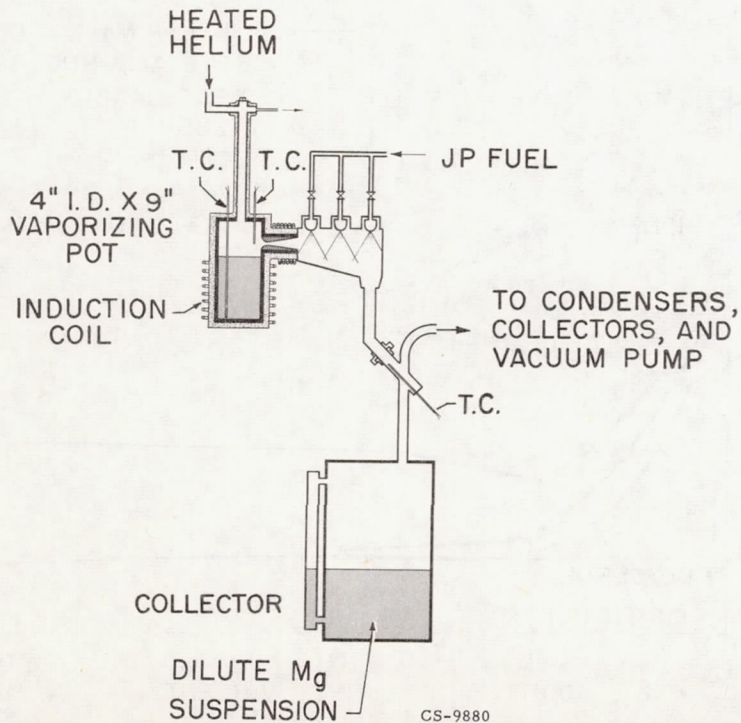

Figure 6. - Preparation of small particles from magnesium vapor.

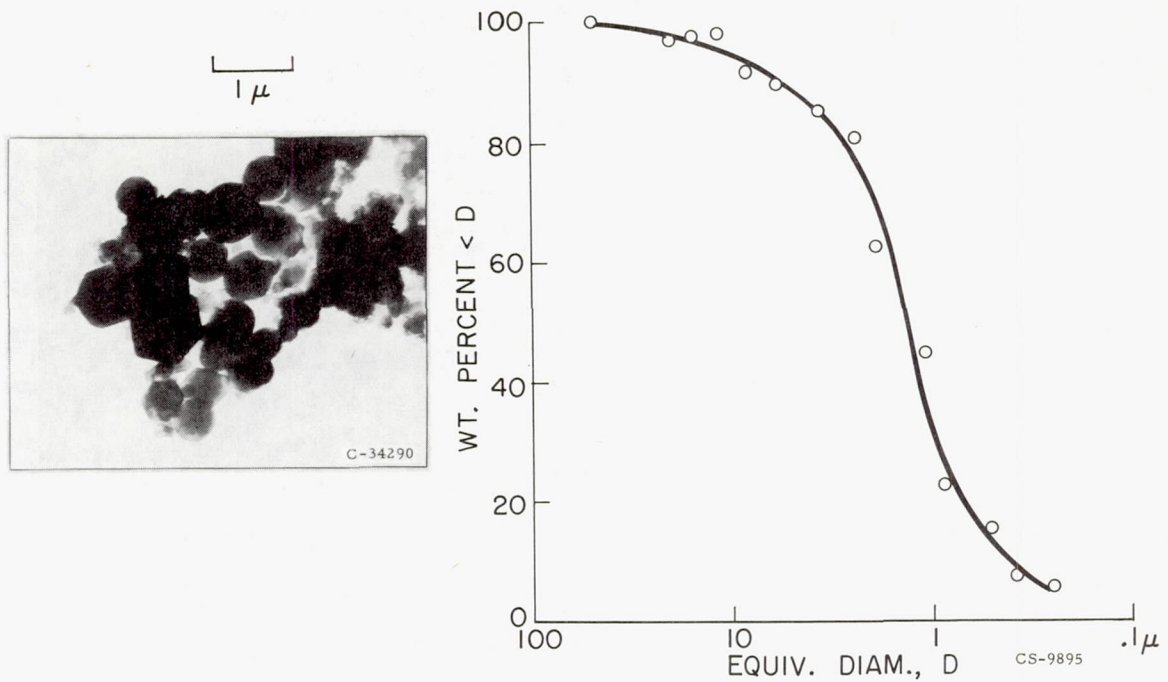

Figure 7. - Particles from magnesium vapor.

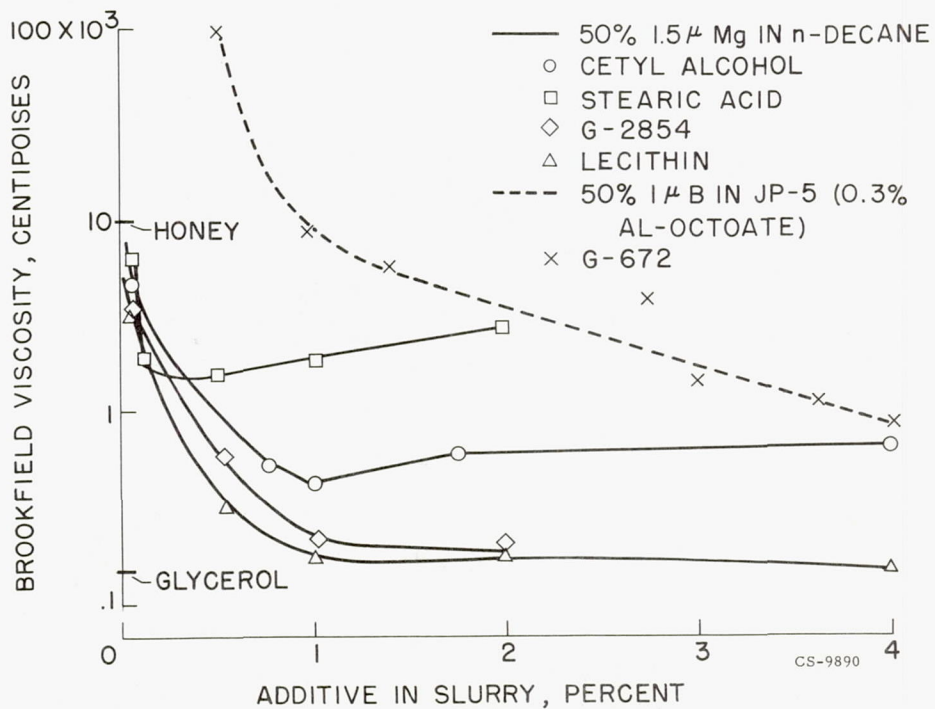

Figure 8. - Dispersing effect of surface-active agents.

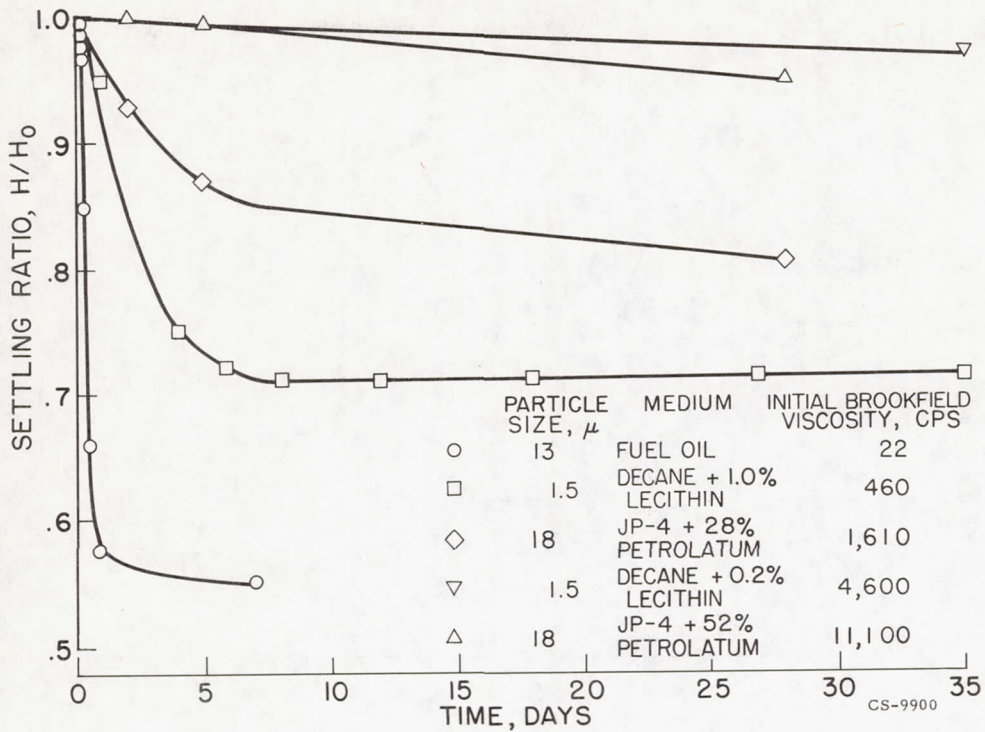

Figure 9. - Settling characteristics of 50-percent magnesium in various media. H, height of column of settled particles; H_0 , height of liquid column.

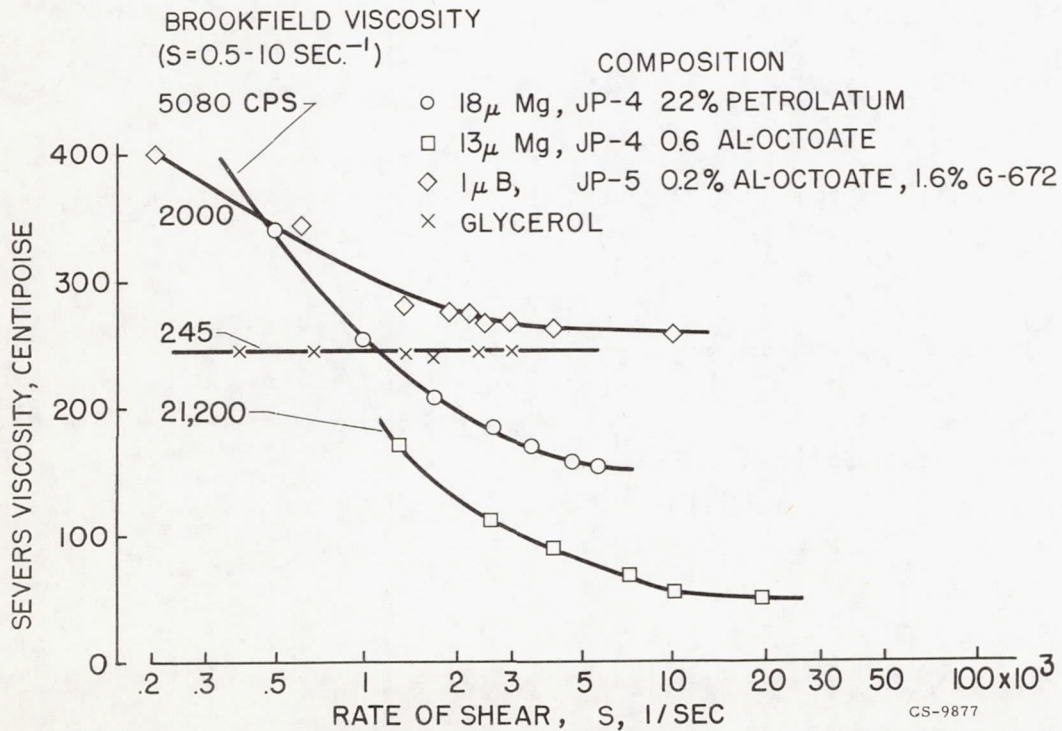

Figure 10. - Effect of rate of shear on viscosity of 50-percent slurries

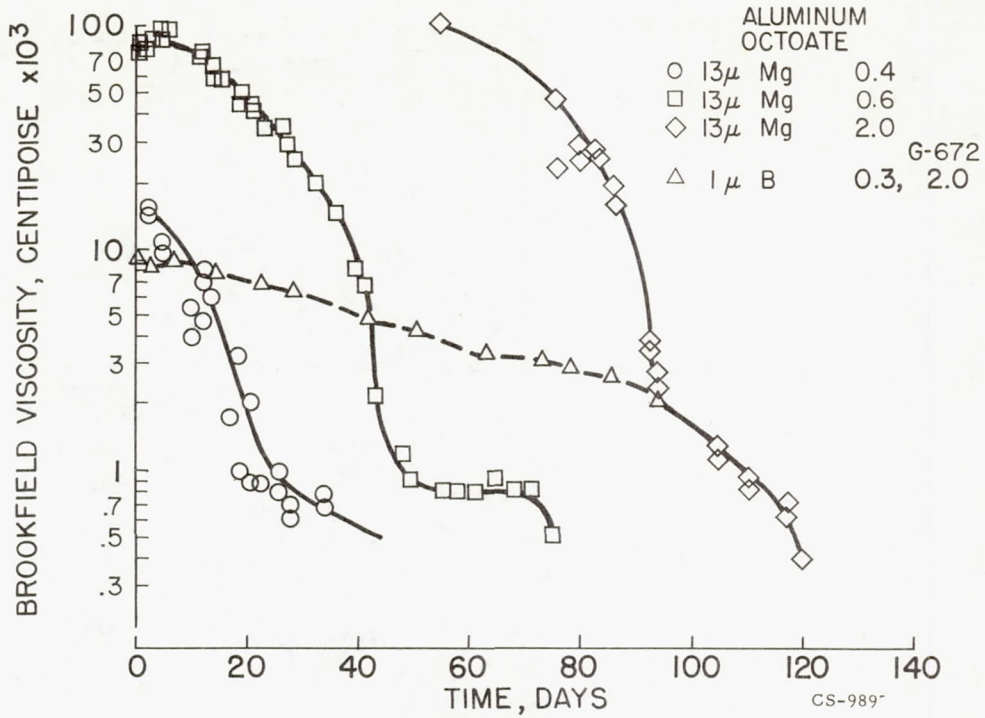

Figure 11. - Aging of 50-percent slurries containing gelling agent.

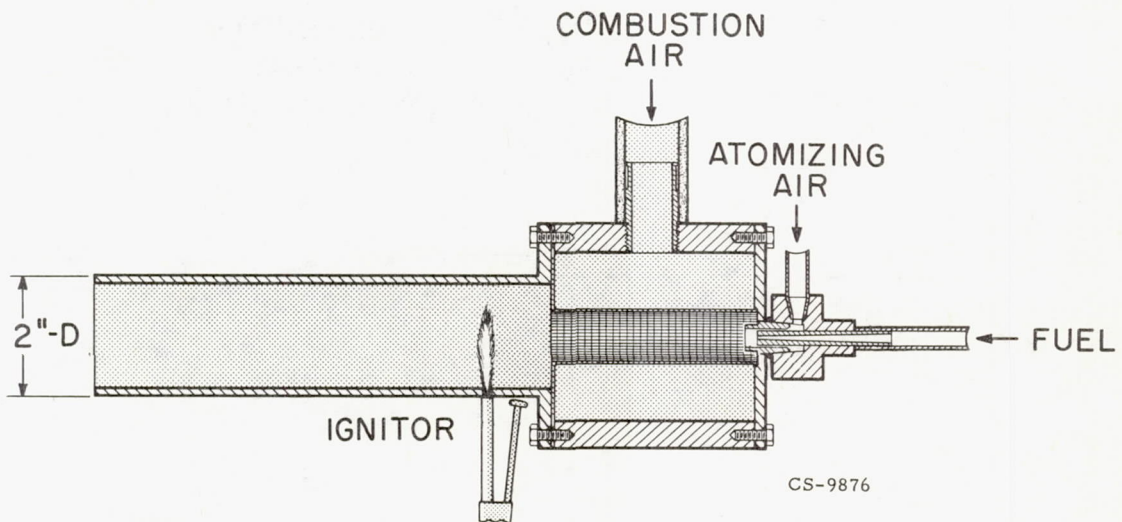

Figure 12. - Blow-out velocity apparatus.

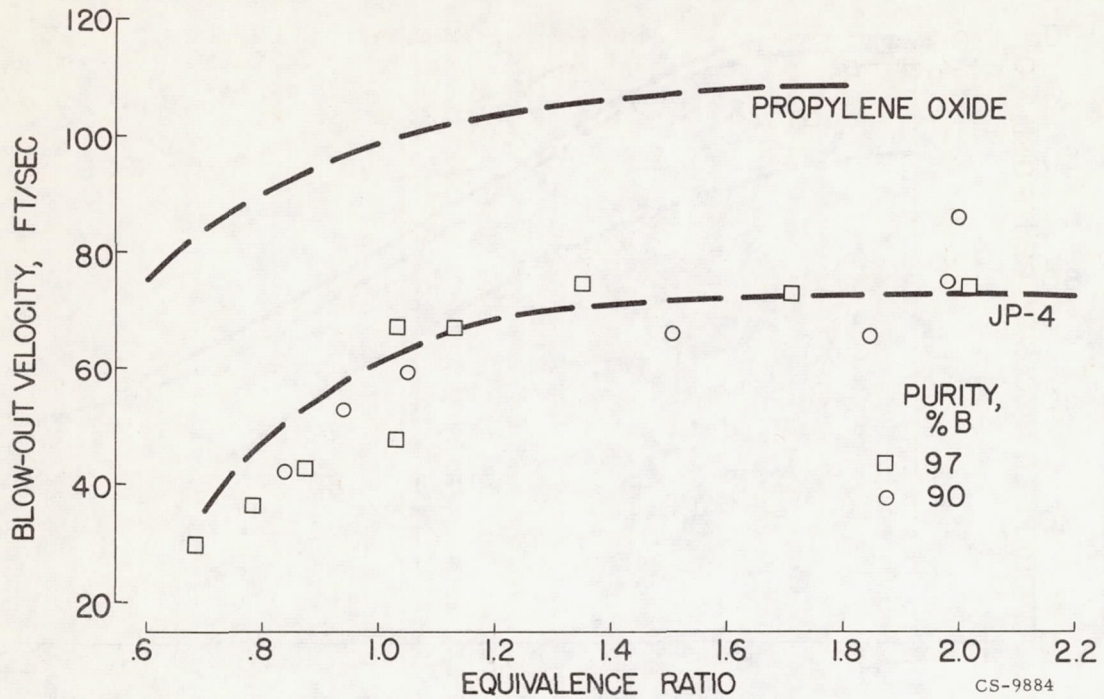

Figure 13. - Blow-out velocity of two 50-percent boron slurries. Burner diameter, 2 inches.

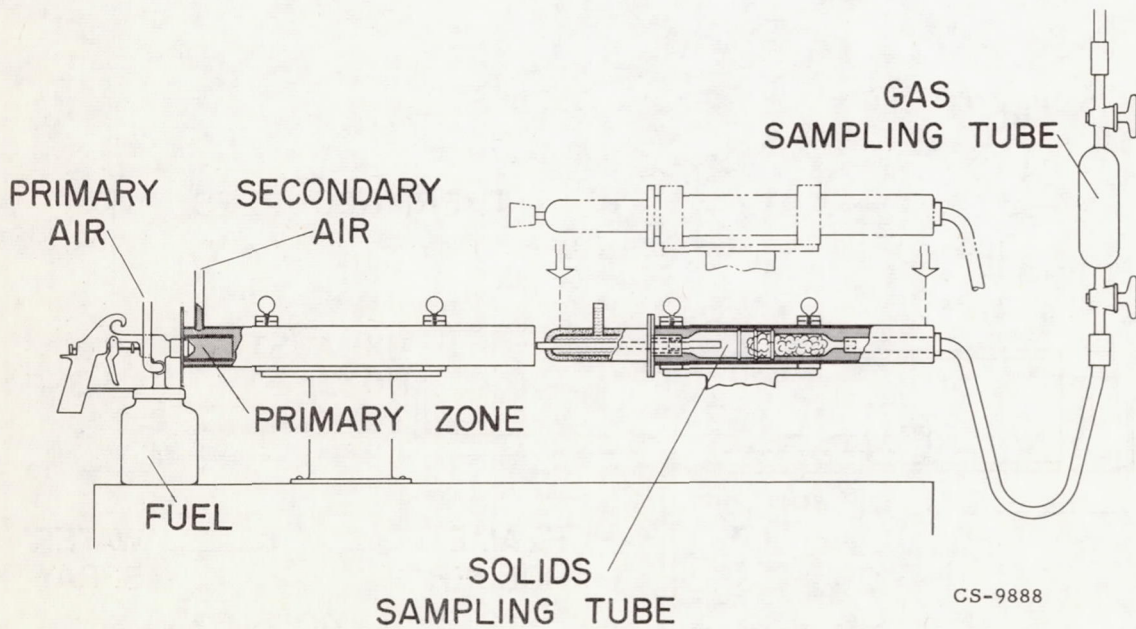

Figure 14. - Slurry burner and exhaust sampling device.

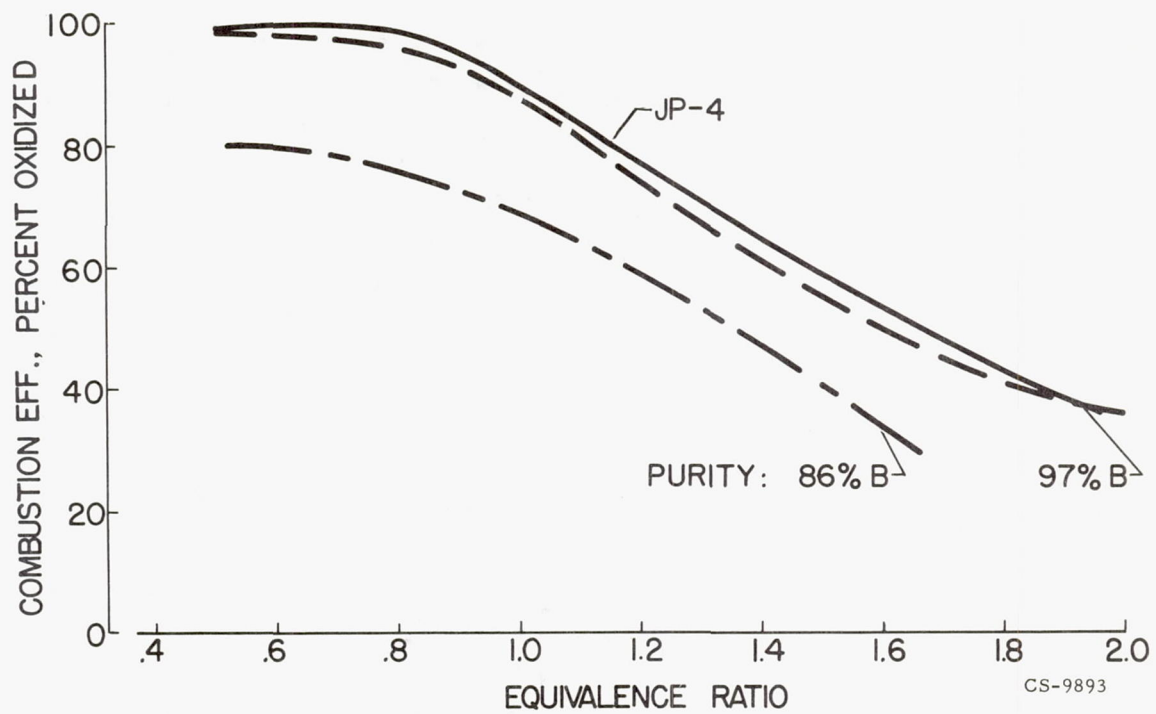

Figure 15. - Combustion efficiency of 30-percent boron slurries.

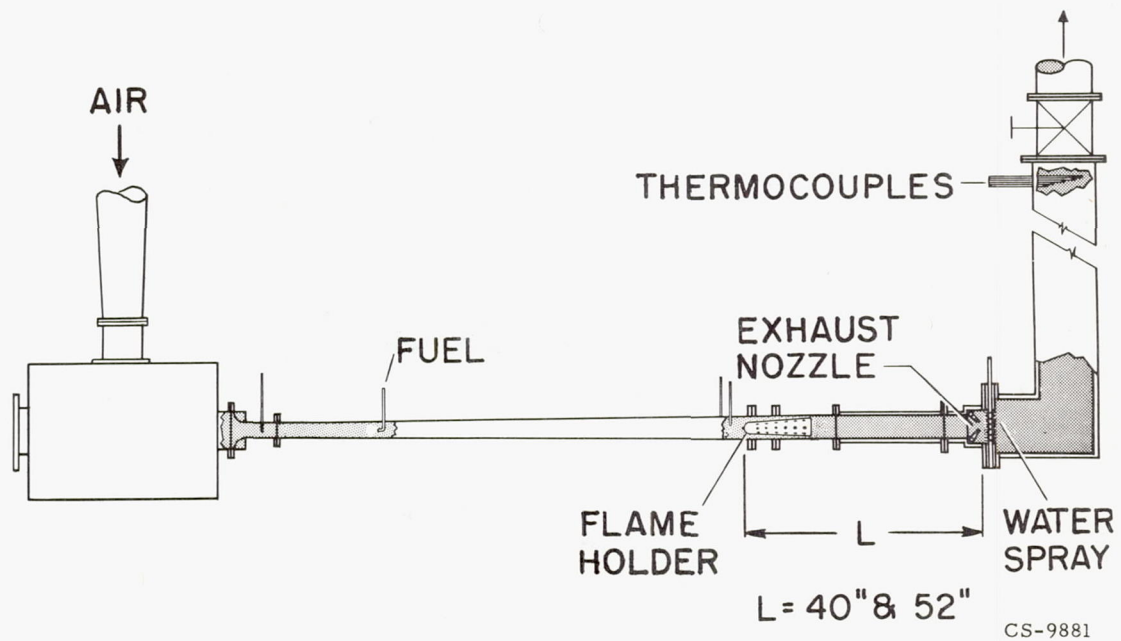

Figure 16. - 5-Inch-diameter ram-jet burner used for boron fuels.

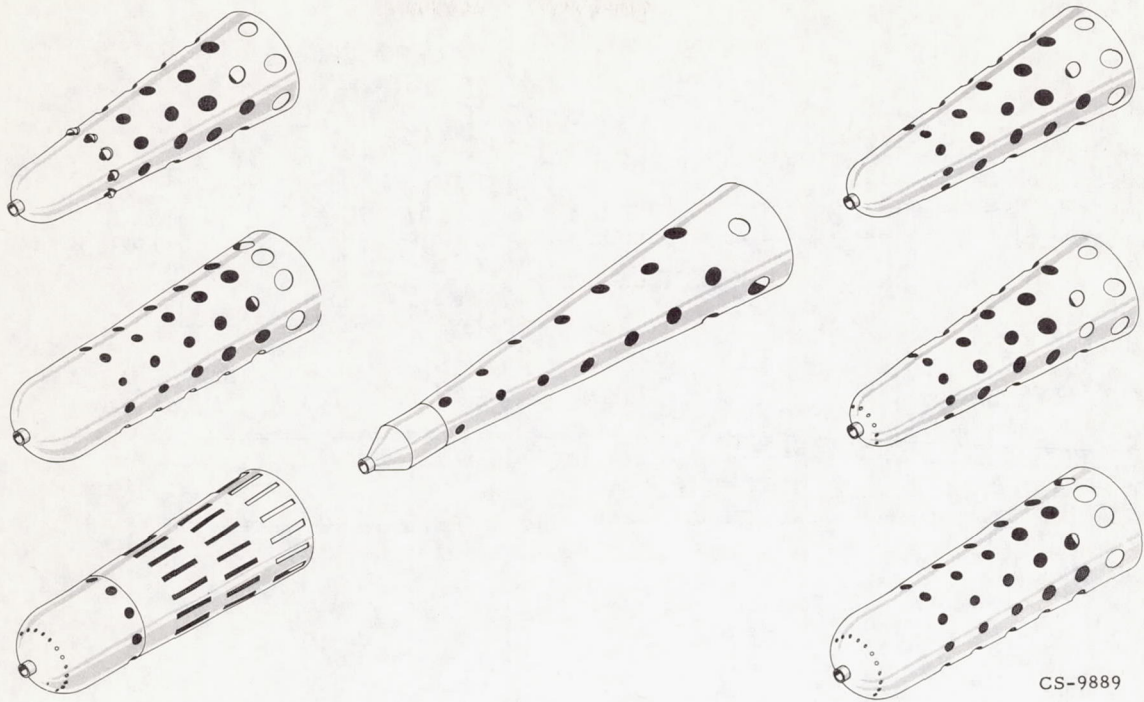

Figure 17. - Boron-slurry flame holders.

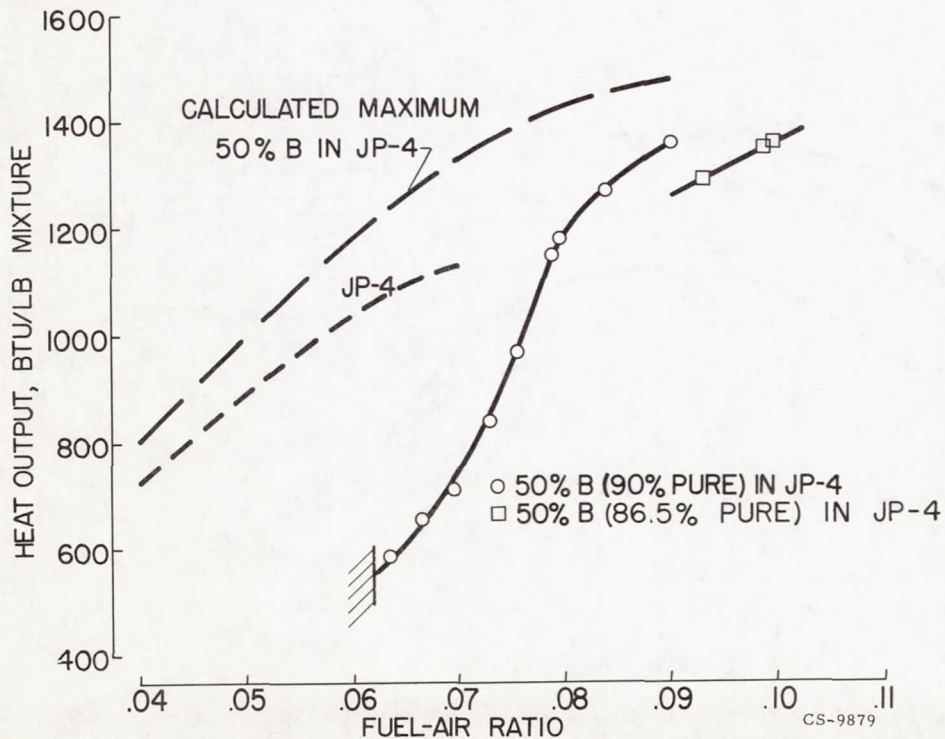

Figure 18. - Combustion of boron slurries in 5-inch diameter burner. Burner length, 40 inches; temperature, approximately 680° R; pressure, 11.8 to 14.8 square inches absolute; velocity, 131 to 181 feet per second.

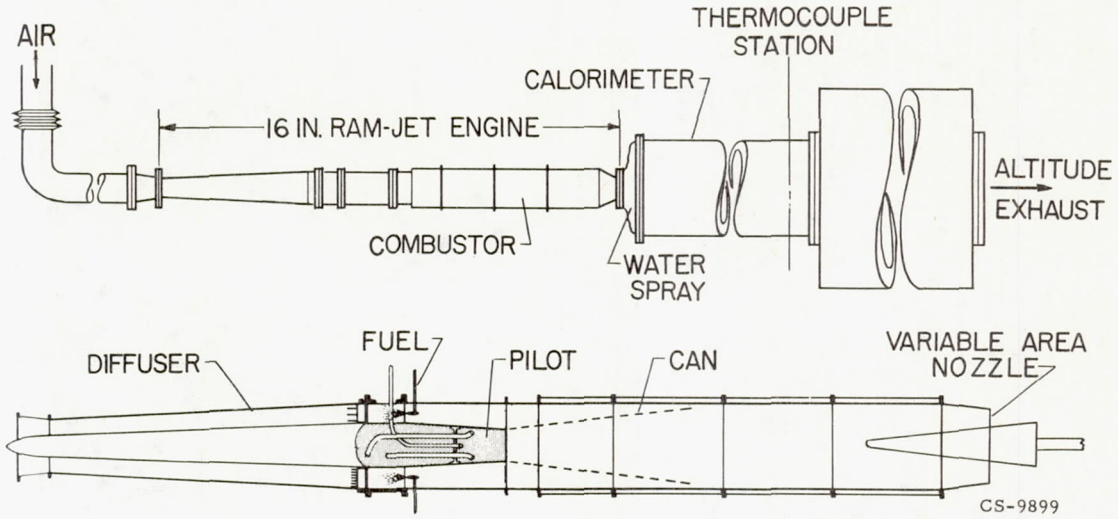

Figure 19. - 16-Inch-diameter ram-jet engine used for boron fuels.

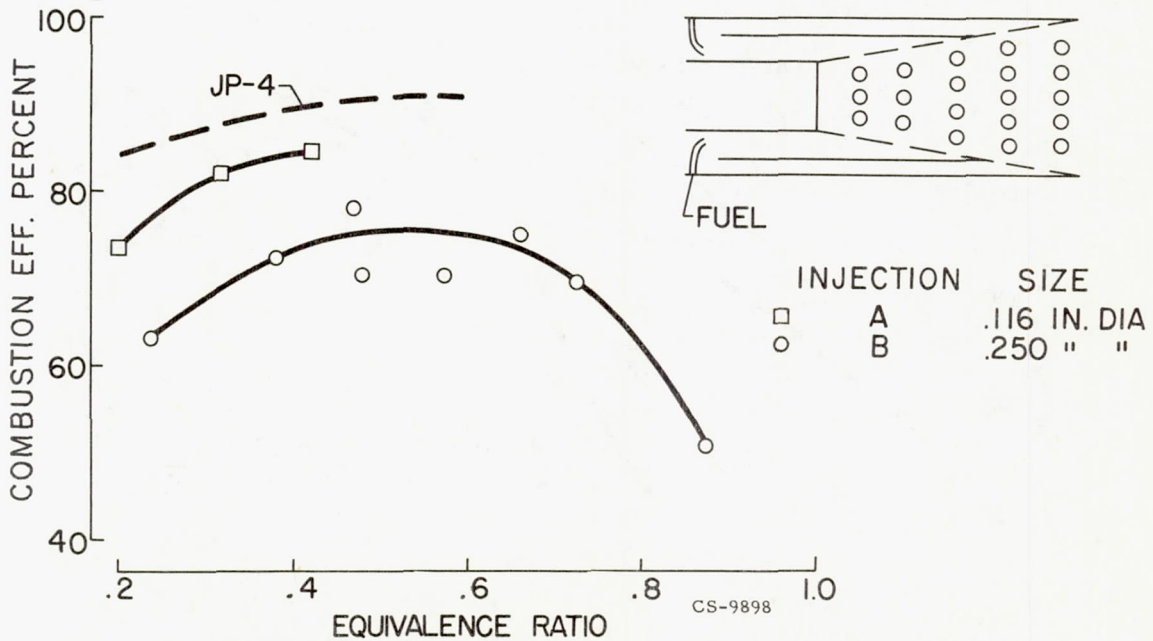
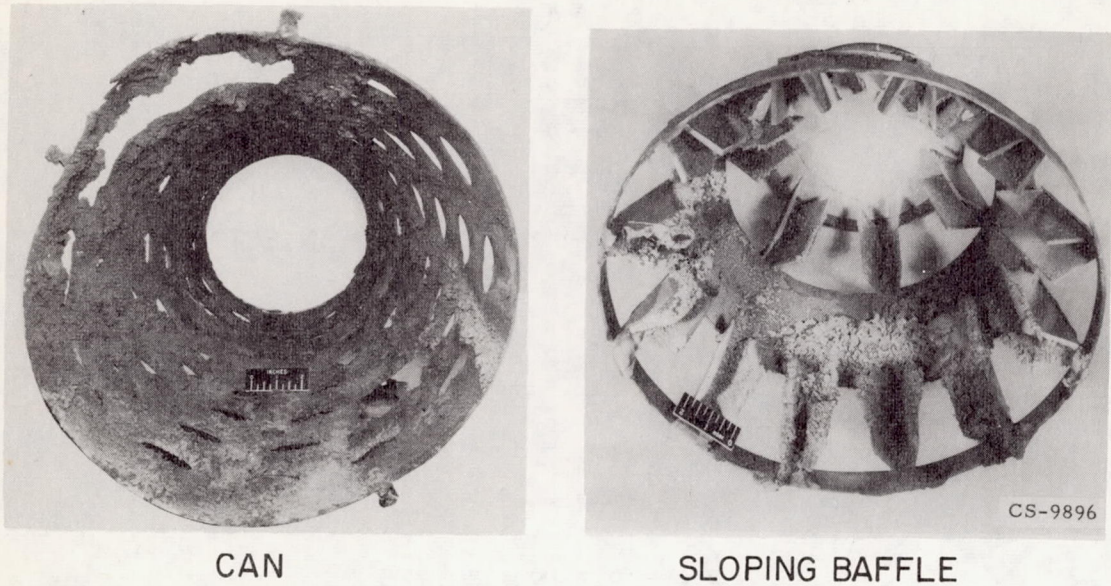

Figure 20. - Performance of 50-percent boron slurry in 16-inch ram-jet combustor. Pressure, 1 atmosphere; velocity, 260 feet per second; temperature, 560° F.



CAN

SLOPING BAFFLE

Figure 21. - Combustors after use of boron fuel.

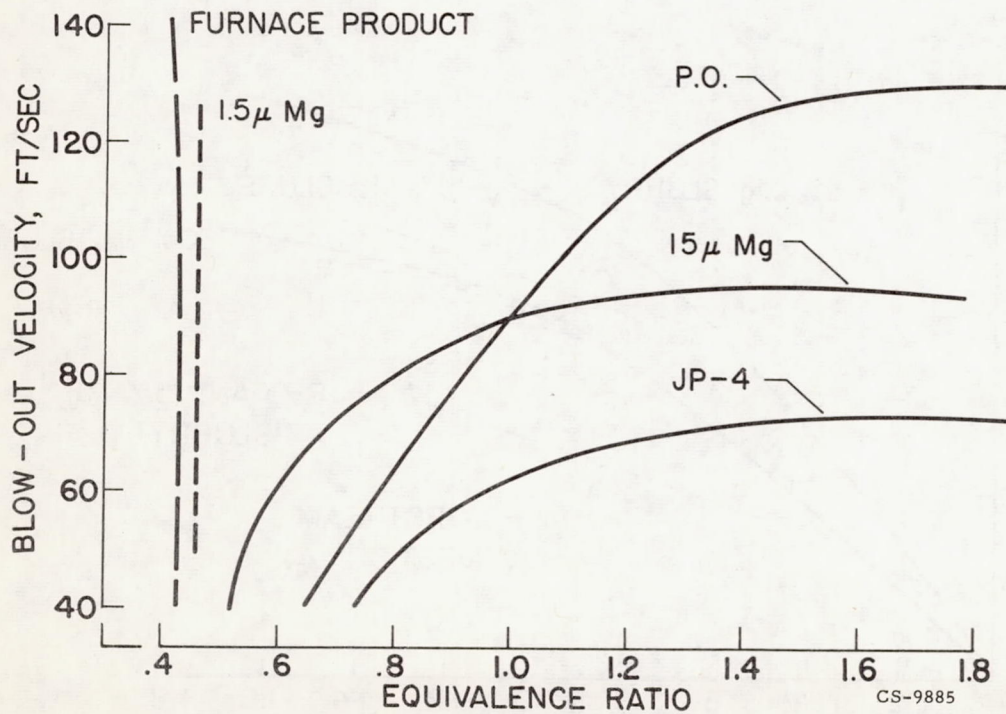
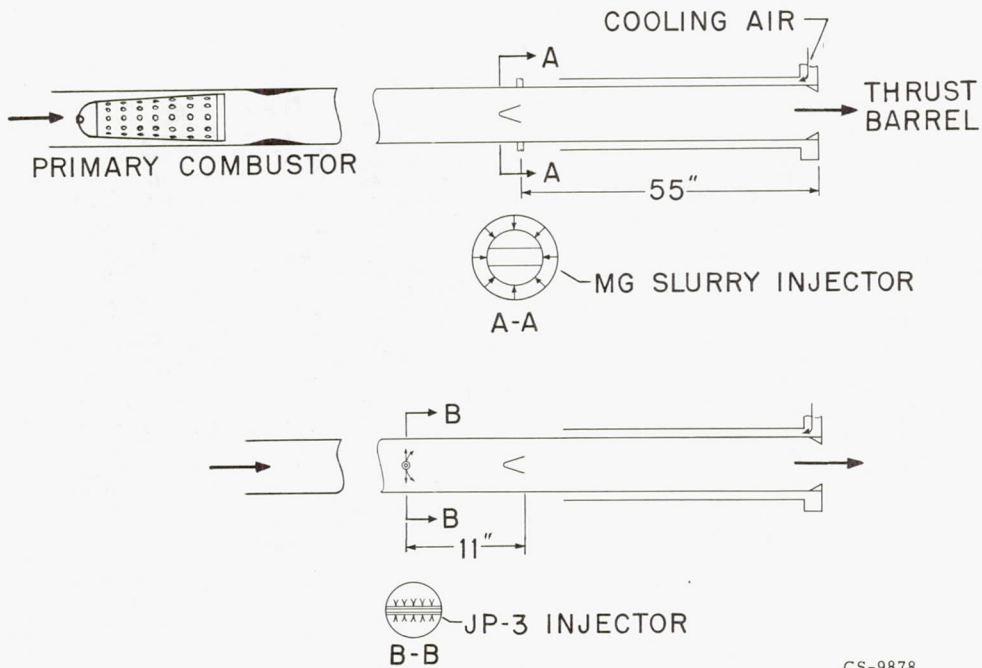

Figure 22. - Flame stability of 50-percent magnesium slurries.



CS-9878

FLAMEHOLDER BLOCKED AREA 31%

Figure 23. - Simulated afterburner of 6-inch diameter.

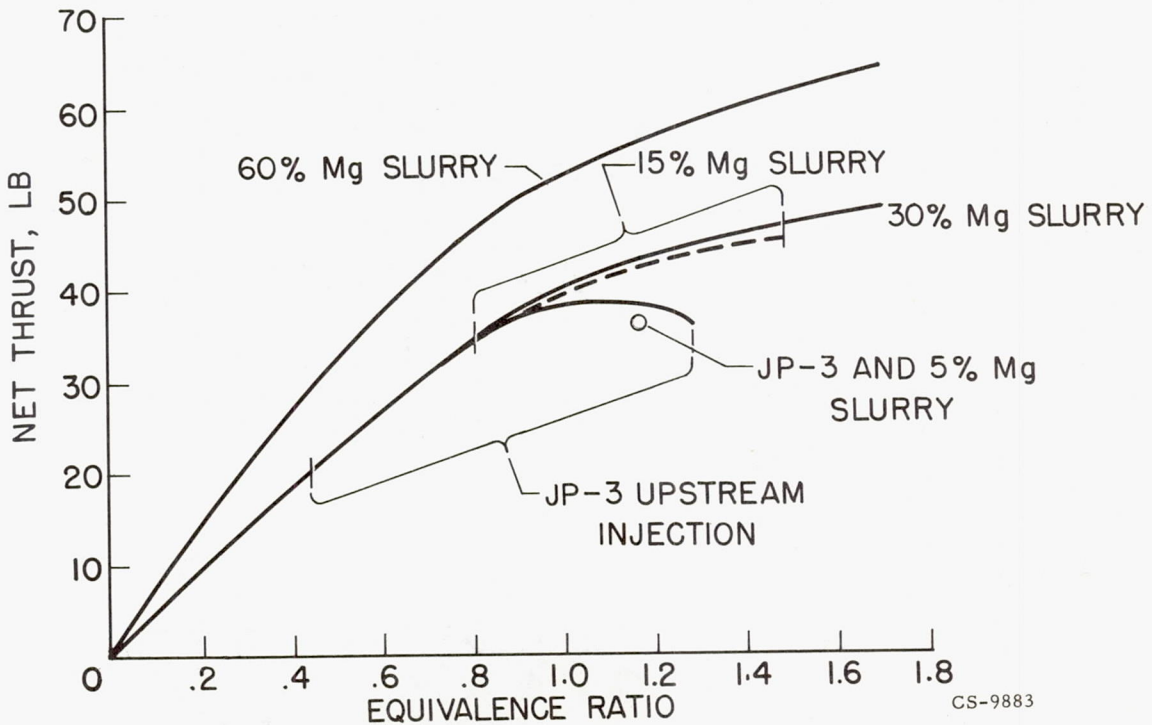

CS-9883

Figure 24. - 6-inch-diameter afterburner performance with magnesium slurry.

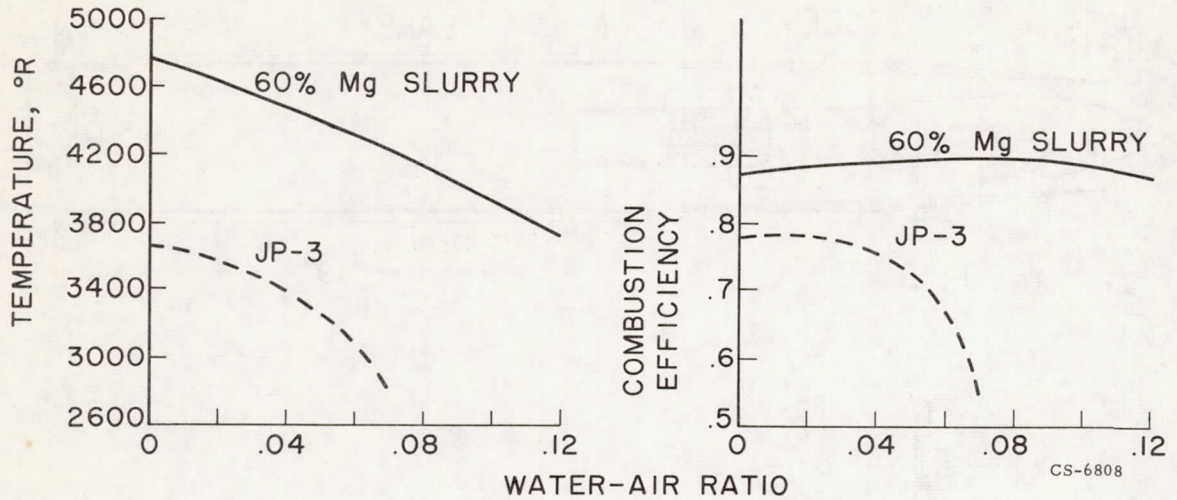

Figure 25. - Temperature and combustion efficiency in small-scale afterburner.

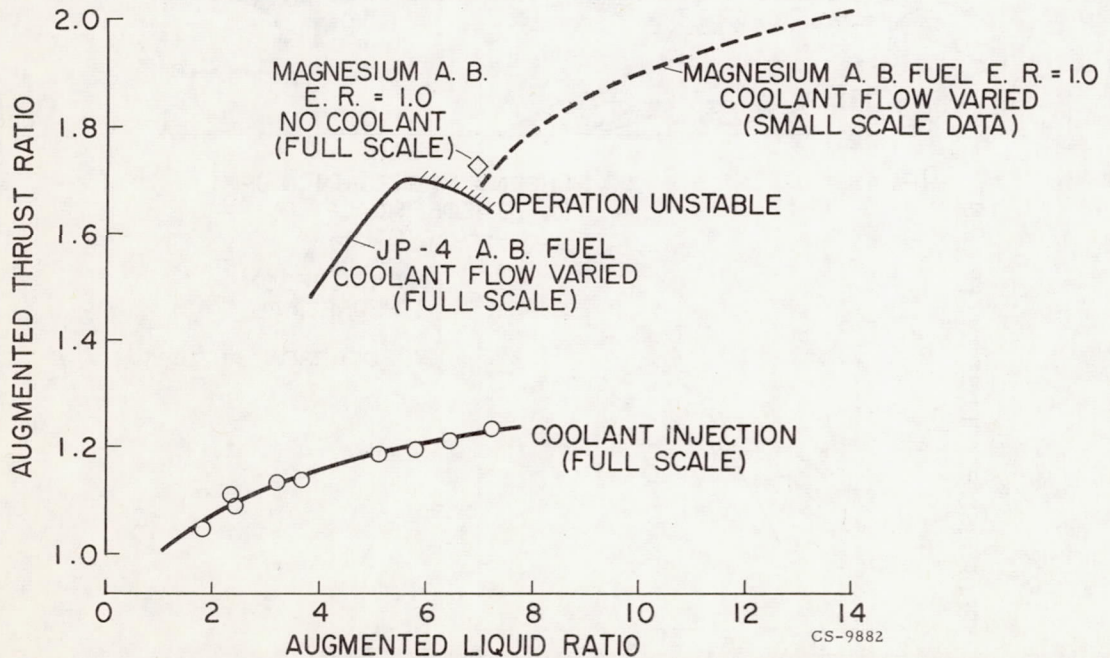
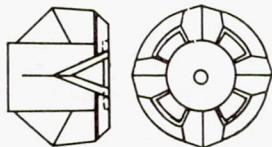
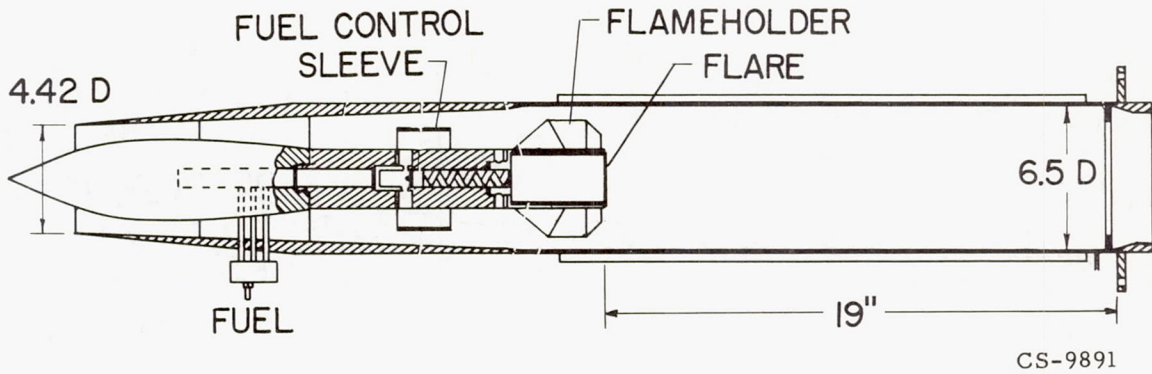

Figure 26. - Turbojet engine thrust augmentation with magnesium slurries (sea level static).



FLAMEHOLDER

Figure 27. - Ram-jet engine used with magnesium slurry.

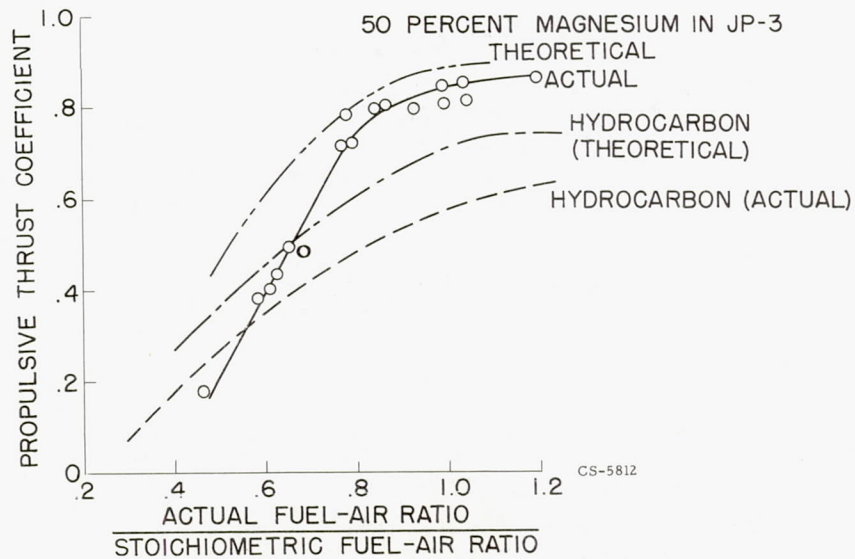
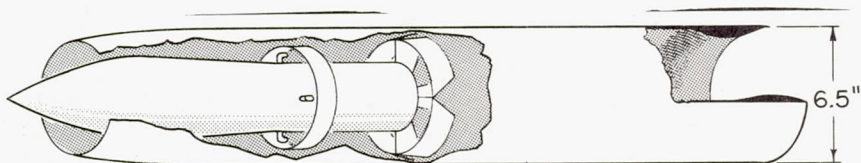

Figure 28. - Magnesium slurry performance.