

RESEARCH MEMORANDUM

EVAPORATION OF JP-5 FUEL SPRAYS IN AIR STREAMS

By Hampton H. Foster and Robert D. Ingebo

Lewis Flight Propulsion Laboratory
Cleveland, Ohio

NATIONAL ADVISORY COMMITTEE
FOR AERONAUTICS

WASHINGTON

February 21, 1956

NATIONAL ADVISORY COMMITTEE FOR AERONAUTICS

RESEARCH MEMORANDUM

EVAPORATION OF JP-5 FUEL SPRAYS IN AIR STREAMS

By Hampton H. Foster and Robert D. Ingebo

SUMMARY

A continuous sampling-probe technique was used to determine the percentage of JP-5 fuel spray evaporated under conditions common in ram-jet engines. Fuel was injected contrastream from a multiple-orifice injector, and sampling data were obtained at distances of 7 to 18 inches downstream of the injector. In order to determine their effect on the evaporation of JP-5 fuel sprays, inlet-air conditions were varied over the following ranges: air velocities, 138 to 370 feet per second; air static pressures, 15 to 35 inches of mercury absolute; and air temperatures, 80° to 700° F.

Results from this investigation gave the following expression for fuel evaporation:

$$N = 7.4 L^{0.33} \Delta T^{0.28} \left(\frac{U_a + U_f}{100 + U_a} \right)^2$$

where N is the percentage of JP-5 fuel spray evaporated, L is the distance downstream from the injector, ΔT is the heat-transfer driving force (the difference between the air temperature and the surface or wet-bulb temperature of the drops), U_a is the air velocity, and U_f is the injection velocity of the fuel. The use of ΔT in this expression reflects the combined effect of air-stream temperature and pressure.

INTRODUCTION

Low-volatility fuels, such as JP-5, are desirable for use in high-altitude aircraft jet engines from the standpoint of low fuel-tank losses. Also, they present less fire hazard, under some conditions, than currently used JP-4 fuel. However, the very low evaporation rate of such fuels may yield poor performance. Therefore, knowledge of the factors that affect the evaporation rate of JP-5 fuel is useful to the combustor designer.

An experimental study of the effect of combustor-inlet conditions on the evaporation of isooctane sprays in high-velocity air streams is reported in reference 1. Since this type of data is not available for very low-volatility fuels, such as JP-5, the following experimental investigation was made using a continuous sampling-probe technique similar to that described in reference 1. The JP-5 fuel was injected contra-stream from a multiple-orifice injector, and spray samples were obtained at distances of 7 to 18 inches downstream of the injector. Inlet-air conditions were varied over the following ranges: air velocity, 138 to 370 feet per second; air static pressure, 15 to 35 inches of mercury absolute; and air temperatures, 80° to 700° F. In this investigation conducted at the NACA Lewis laboratory, the percentage of JP-5 fuel spray evaporated was found to be a function of the heat-transfer driving force ΔT , the downstream distance L , the air velocity U_a , and the fuel injection velocity U_f .

APPARATUS AND PROCEDURE

Installation

A schematic diagram of the test installation is presented in figure 1. Air at a pressure of 40 pounds per square inch gage was drawn from the laboratory air-supply system. The air was preheated by burning some MIL-F-5624C, grade JP-4, fuel in a turbojet-engine combustor connected in the air-supply line.

Test section. - The preheated air passed through a 12-foot length of straight Inconel pipe having an inside diameter of $8\frac{3}{8}$ inches. Flow straighteners in the form of two perforated plates were located upstream of the test section as shown in figure 1. Two relatively flat air-velocity profiles resulting from the use of the plates are shown in figure 2. The sampling station was located $6\frac{3}{4}$ feet downstream of the second plate and the fuel nozzle positions were 7, 12, and 18 inches upstream of the sampling station. The air then flowed through the expansion bellows to the downstream control valves and into the altitude-exhaust system.

Fuel and fuel system. - The fuel used throughout the investigation was JP-5. Table I shows an analysis of this fuel. The fuel was delivered to the injector by pressurized nitrogen.

The fuel injector is shown in figure 3. Initially a single 0.041-inch-orifice injector similar to the one used in reference 1 was used, but the single orifice produced excessive spreading of the JP-5 fuel.

A five-hole injector, which had a 0.021-inch diameter center orifice surrounded by four equally spaced orifices with 0.018-inch diameters, was then adopted. The injector was positioned on the centerline of the test section and pointed directly upstream. The JP-5 fuel was heated to $212^{\circ} \pm 8^{\circ}$ F, before entering the injector. The injection pressure was 26 pounds per square inch gage. For the air velocities used, the resulting JP-5 fuel spray was assumed to be somewhat coarser than the iso-octane spray with a mean drop size of 50-micron diameter as described in reference 2.

The air was measured by a variable orifice located upstream of the air-flow control valves. The air temperature was measured with unshielded thermocouples at the orifice and at a distance of $3\frac{1}{2}$ feet upstream of the sampling station. Wall static-pressure taps were positioned at the thermocouple stations and at the sampling station.

The JP-5 fuel-flow rate was determined with a rotameter. Measurements of the fuel temperature and pressure were taken at the fuel injector. The preheater fuel flow was also measured by a rotameter.

Sampling System

A schematic diagram of the sampling system is shown in figure 4. Samples of the spray were continuously withdrawn from the test section with a single probe. The fuel-air sample flowed vertically downward into the gas-sample combustor.

Probe. - The probe was constructed of 3/16-inch outside-diameter Inconel tubing with a 0.032-inch wall. The 2-inch section of the probe, which pointed directly into the air stream, was tapered to the probe mouth as shown in figure 4.

Analyzing section. - The sample passed from the probe into a combustor. An oxygen-hydrogen pilot flame (with a continuous spark at the spark electrodes in the combustor) was used to ensure complete combustion of the collected fuel. A satisfactory flow rate (measured by critical-flow orifices) for the pilot flame was 0.07 and 0.28 pound per hour for the hydrogen and oxygen, respectively. In general, the analyzer readings were not affected by the pilot flame.

When necessary, diluent air was added to the sample at the combustor. The diluent-air-flow rate was metered with a critical-flow orifice.

The flow rate of the gas sample was measured with a rotameter after the sample had been cooled to about 85° F and the water condensate removed. The temperature and static pressure of the sample were determined

at the rotameter inlet. From the rotameter, the sample passed through a control valve to a two-cylinder diaphragm pump. The sample was then discharged from the pump to an NACA mixture analyzer (ref. 3), which dried the sample and indicated the quantity of carbon dioxide present in the sample. A continuous analysis of the sample was obtained, and the fuel-air ratio of the sample was indicated on a self-balancing potentiometer.

The zero setting of the NACA mixture analyzer was checked before and after each run. The analyzer calibration was also checked periodically with a standard-gas sample. A gage pressure of at least 2 inches of mercury was maintained at the analyzer inlet. For runs in which the air preheater was used, the fuel-air ratio that resulted from the combustion products of the JP-4 fuel was determined before the JP-5 fuel flow was started. This small fuel-air-ratio value was subtracted from each of the measured total fuel-air ratios.

Sampling methods. - Continuous samples were withdrawn at, above, and below stream velocity. When sampling somewhat below stream velocity, some of the intercepted flow is forced to spill around the probe. Most of the droplets, however, enter the probe because their momentum is greater than that of the fuel vapor and air mixture; this is known as the spillover method of determining the liquid fuel-air ratio at the sampling point. The ratio of the weight of droplets collected to the weight that would be collected if no droplets were deflected around the probe is defined as the collection efficiency of the spillover method. This method is described at some length in references 1 and 4.

Sampling slightly above stream velocity results in an increase in intercepted air and fuel vapor, but little or no increase in droplets entering the probe because of their greater momentum.

Methods of Analysis

The method of analysis used in reference 1 gave inconsistent results when applied to the JP-5 fuel data. This inconsistency is attributed to the assumption of a constant fuel-droplet collection efficiency of 90 percent. For this report, a new method of analysis (based on equations shown in the appendix) was used. Fuel evaporation was computed on the basis of a probe collection efficiency of 100 percent. A typical data plot is shown in figure 5(a). In the case of excessive data scatter (fig. 5(b)), or insufficient data (fig. 5(c)), the test was repeated. Initially, vertical traverses were obtained by sampling at points across the spray area. Figure 6 shows a relatively symmetric fuel-distribution profile obtained by this method of sampling. Points on the profiles were obtained from data similar to those of figure 5(a) and the new method of analysis.

Integrated values of W_f and W_L , for use in computing the percentage of fuel evaporated, were found by graphical integration of plots of the points on the traverse against the square of their respective distances from the spray axis. The integrated value of percentage of fuel evaporated (fig. 6) is 75.6. Values of the percentage evaporated at several single points are shown on the figure for comparison. These data show that the integrated value (75.6 percent) agrees fairly well with single point values obtained near the centerline of the duct.

Data for three test conditions are included in the following table to show the comparison between integrated and single-point percentage values of JP-5 fuel evaporated:

Run	Air flow, lb/sec	Air pressure, P_a , in. Hg abs	Air velocity, U_a , ft/sec	Air temperature, T_a , $^{\circ}F$	Probe distance from injector, L, in.	Percent evaporated	
						At single probe position, 1/2 in. below spray axis	At several probe positions, $\frac{3}{4}$ in. traverse; integrated values
A	3.76	29.3	141	86	12	19	16.5
B	3.82	29.6	138	80	7	18	17.0
C	2.74	27.5	212	615	12	72	75.6

Good agreement was found between the quantity of fuel evaporated at a single point 1/2 inch below the spray axis and values obtained by traversing the entire spray. Inasmuch as this fuel-spray study deals only with the percentage of fuel spray evaporated and does not include fuel-spray spreading, measurements were made at a single point 1/2 inch below the spray axis during the remainder of this investigation. These data are included in table II.

Experimental Procedure

At a single air-flow setting and fuel-injection rate, fuel sampling data were obtained over the following range of variables:

Inlet-air temperatures, $^{\circ}F$	80 to 700
Inlet-air velocities, ft/sec	138 to 370
Inlet-air static pressures, in. Hg abs	15 to 35
Axial distances from fuel injector, in.	7, 12, 18
Fuel-injection pressure drop, lb/sq in.	26
Fuel temperature, $^{\circ}F$	212 \pm 8

RESULTS AND DISCUSSION

The mass fraction E of fuel spray evaporated was investigated for the following air-stream and fuel-spray parameters:

$$E = f(L, P_a, T_a, U_a, T_{WB}, U_f) \quad (1)$$

where L is the distance downstream from the injector; P_a , T_a , and U_a are air-stream pressure, temperature, and velocity relative to the duct, respectively; T_{WB} is the wet-bulb temperature of the fuel drop; and U_f the injection velocity of the fuel relative to the duct and at the injector exit.

In order to determine the general effect of L , T_a , and U_a on E , a plot of E against L was made (fig. 7) for different air temperatures and velocities. Air-stream static pressure and fuel-injection pressure were held constant. Figure 7(b) shows a cross plot of figure 7(a) in which E is plotted against T_a to show the general effect of air temperature. Evaporation data were also obtained for a static-pressure range of 15 to 35 inches of mercury absolute as shown in figure 7(c). These figures show that the influence of air pressure is small. This result is consistent with the observed effect of air pressure on the wet-bulb temperature reported in references 2 and 5.

Investigations of vaporization rates for single droplets (ref. 5) and isooctane droplets in sprays (ref. 2) have shown evaporation to be a function of the heat-transfer driving force ΔT (the difference between the air temperature and the surface or wet-bulb temperature of the droplets). Thus, if the effect of air temperature and air static pressure on evaporation are combined as a function of the temperature difference ΔT , equation (1) becomes

$$E = f(L, \Delta T, U_a, U_f) \quad (2)$$

Values of ΔT for JP-5 fuel were obtained from the plot shown in figure 8, which is based on the correlation of psychrometric data with boiling points given in reference 5. The 50-percent boiling point of JP-5 fuel (429° F) was used in this investigation. From plots of $\log E$ against $\log L$ and $\log \Delta T$, respectively, E could be correlated with L and ΔT as shown in figure 9. The equation for the straight line in this plot may be written

$$N = 6.3 \Delta T^{0.28} L^{0.33} \quad \text{where } N = 100E. \quad (3)$$

In figure 9, the air velocity was varied from 216 to 370 feet per second; the effect of U_a on E appeared small and no definite trend

was evident. Similar plots were made for isooctane data (ref. 1) and good agreement was obtained with these exponents over the same air-velocity range.

The most obvious reason for the slight velocity effect is that although the increase in stream velocity reduces the time for evaporation, the increased stream velocity also improves fuel atomization. Thus, an attempt to generalize and include the atomization effect was treated as follows: When fuel is injected contrastream, the liquid-jet velocity U_f is negative and the velocities are additive; therefore for this case,

$$E = f[L, \Delta T, U_a, (U_a + U_f)]$$

The effect of fuel-injection pressure on the mass fraction evaporated E is included as a function of fuel injection velocity U_f in the term $(U_a + U_f)$.

A plot of $\log E$ against $\log U_a$ for isooctane data obtained from reference 1 gave a group of curves for various fuel-injection pressures. A single curve was obtained by plotting $\log E$ against $\log (U_a + U_f)$, which also appeared relatively flat at a value of 250 feet per second for U_a . Because the curve appeared hyperbolic, a plot of $1/\sqrt{E}$ against $1/(U_a + U_f)$ was made. From the slope of this plot, it was found that the evaporation data could be correlated with the group $(U_a + U_f)/(100 + U_a)$ where U_a and U_f are expressed in feet per second. This group shows the effect of air velocity on the percentage evaporated to be negligible at high velocities, possibly as a result of the canceling effect of short residence time and small drop sizes on evaporation.

Thus, equation (3) could be rewritten as follows:

$$N = C \Delta T^{0.28} L^{0.33} \left(\frac{U_a + U_f}{100 + U_a} \right)^2 \quad \text{where } N = 100E$$

From the plot of this equation shown in figure 10, values of the proportionality constant C were found to be 7.4 and 10 for JP-5 fuel and isooctane, respectively. The larger constant obtained for isooctane indicated a better atomization probably due to its low surface tension compared with JP-5 fuel. The term $\frac{U_a + U_f}{100 + U_a}$ is an empirical group, which combines the over-all effects of fuel-drop size, acceleration, residence time, and Reynolds number on the percentage of JP-5 fuel evaporated. For air velocities, injection pressure drops, and injectors considerably different from those of this investigation or those reported in reference 1, the foregoing velocity grouping may not describe the over-all processes effectively.

CONCLUSIONS

The effect of air-stream and fuel-spray parameters on the evaporation of a JP-5 fuel spray were found to be described satisfactorily by the expression

$$N = 7.4 L^{0.33} \Delta T^{0.28} \left(\frac{U_a + U_f}{100 + U_a} \right)^2$$

where N is the percentage of JP-5 fuel evaporated, L is the distance downstream from the injector (in.), ΔT is the difference between air and wet-bulb temperature ($^{\circ}\text{F}$), U_a is air velocity (ft/sec), and U_f is the fuel-injection velocity (ft/sec).

For JP-5 fuel, this expression is applicable for downstream distances of 7 to 18 inches, temperature differences of 3° to 385° F, air-stream velocities of 138 to 370 feet per second, air-stream pressures of 15 to 35 inches of mercury absolute, a constant injection pressure of 26 pounds per square inch, and a multiple-orifice fixed-area fuel injector.

Lewis Flight Propulsion Laboratory
National Advisory Committee for Aeronautics
Cleveland, Ohio, November 3, 1955

APPENDIX - CALCULATION OF FUEL-SPRAY EVAPORATION

The fuel-air-ratio measurements indicated by the conductivity-type mixture analyzer included the concentration of vapor fuel which was captured along with the liquid-fuel droplets. The following analysis was used to calculate the fuel-spray evaporation from the experimental measurements. The symbols used in this analysis were

- f'_t total fuel-air ratio of sample in probe
- N spray evaporation, percent
- W_a calculated weight flow of air intercepted by probe, lb/hr
- W'_a weight flow of air captured by probe, ($W'_a = W_a$ at zero spillover)
lb/hr
- W_f weight flow of fuel captured by probe, lb/hr
- W_l weight flow of liquid fuel captured by probe, lb/hr
- W_v weight flow of vapor fuel captured by probe, lb/hr

The total fuel-air ratio in the sampling probe may be expressed as

$$f'_t = \frac{W_f}{W'_a} = \frac{W_l}{W'_a} + \frac{W_v}{W'_a}$$

or in differential form as

$$df'_t = d \frac{W_l}{W'_a} + d \frac{W_v}{W'_a}$$

When the sampling velocity is at air-stream velocity or slightly above or below, the weight-flow ratio of fuel vapor to air is approximately constant, and its differential is therefore zero. Also, inasmuch as the collection efficiency (at 100 percent) is approximately constant for the foregoing conditions, W_l is also constant, so that

$$df'_t = W_l d \left(\frac{1}{W'_a} \right) + 0$$

and

$$W_l = \frac{df'_t}{d \left(\frac{1}{W'_a} \right)}$$

For large deviations in sampling velocity from the air-stream velocity, where W_a' is considerably greater or less than W_a , values of f_t' are diminished because of a corresponding decrease in the liquid-air ratio of the sample. Thus, a plotting of f_t' against $1/W_a'$ gives a curve that is relatively flat at $1/W_a' = 1/W_a$ (fig. 5). The straight line in this portion of the curve has a slope equal to W_l , since a collection efficiency of 100 percent is obtained at air-stream velocity. The total weight of fuel captured by the probe W_F is obtained from the expression

$$W_F = f_t' W_a$$

where f_t' is taken from the point on the curve where $1/W_a' = 1/W_a$. The percentage of spray evaporation N is calculated from

$$N = 100 \left(1 - \frac{W_l}{W_F} \right)$$

REFERENCES

1. Bahr, Donald W.: Evaporation and Spreading of Isooctane Sprays in High-Velocity Air Streams. NACA RM E53I14, 1953.
2. Ingebo, Robert D.: Vaporization Rates and Drag Coefficients for Isooctane Sprays in Turbulent Air Streams. NACA TN 3265, 1954.
3. Gerrish, Harold C., Meem, J. Lawrence, Jr., Scadron, Marvin D., and Colnar, Anthony: The NACA Mixture Analyzer and Its Application to Mixture-Distribution Measurement in Flight. NACA TN 1238, 1947.
4. Longwell, John P., and Weiss, Malcolm A.: Mixing and Distribution of Liquids in High-Velocity Air Streams. Ind. and Eng. Chem., vol. 45, no. 3, Mar. 1953, pp. 667-677.
5. Ingebo, Robert D.: Vaporization Rates and Heat-Transfer Coefficients for Pure Liquid Drops. NACA TN 2368, 1951.

TABLE I. - FUEL ANALYSIS

Fuel property	MIL-F-5624C, grade JP-5
A.S.T.M. distillation D86-46, °F	
Initial boiling point	360
Percentage evaporated	
5	373
10	382
20	399
30	409
40	419
50	429
60	439
70	449
80	459
90	473
95	481
Final boiling point	502
Residue, percent	1.0
Loss, percent	1.0
Hydrogen-carbon ratio	0.160
Heat of combustion, Btu/lb	18,600
Gravity, 60°/60° F	
Specific	0.815
A.P.I.	42.2
Freezing point, °F	-48
Aromatics, percent by volume	
Silica gel	13.7
A.S.T.M.	14.3
Accelerated gum, mg/100 ml	5.0
Aniline point, °F	148.6
Air-jet gum, mg/100 ml	1.0

1962

CA-2 back

TABLE II. - FUEL-SPRAY EVAPORATION AT VARIOUS
TEMPERATURES AND PRESSURES

[One-point fuel-spray sampling; test duct
cross-sectional area, 0.382 sq ft; fuel
flow, 93 lb/hr.]

(a) At various temperatures. Air pres-
sure, 25 inches of mercury absolute

Distance from injector, L, in.	Air velocity, ft/sec	Spray evaporation, percent, at air temperature, T_a , of					
		300° F		500° F		700° F	
		Run		Run		Run	
7	216	K	31	F	61	J	66
	270	L	32	E	58	G	65
	324	M	36	D	62	H	60
	370	N	33	C	56	I	63
12	216	K	42	F	65	J	78
	270	L	43	E	64	G	78
	324	M	45	D	67	H	81
	370	N	43	C	65	I	80
18	216	K	51	F	71	J	79
	270	L	47	E	70	G	84
	324	M	45	D	68	H	77
	370	N	49	C	76	I	89

(b) At various pressures. Air temperature,
500° F

Distance from injector, L, in.	Air velocity, ft/sec	Spray evaporation, percent, at air pres- sure of					
		15 in. Hg abs		25 in. Hg abs		35 in. Hg abs	
		Run		Run		Run	
7	270	S	60	E	58	T	56
	324	R	62	D	62	U	56
12	270	S	67	E	64	T	66
	324	R	68	D	67	U	64

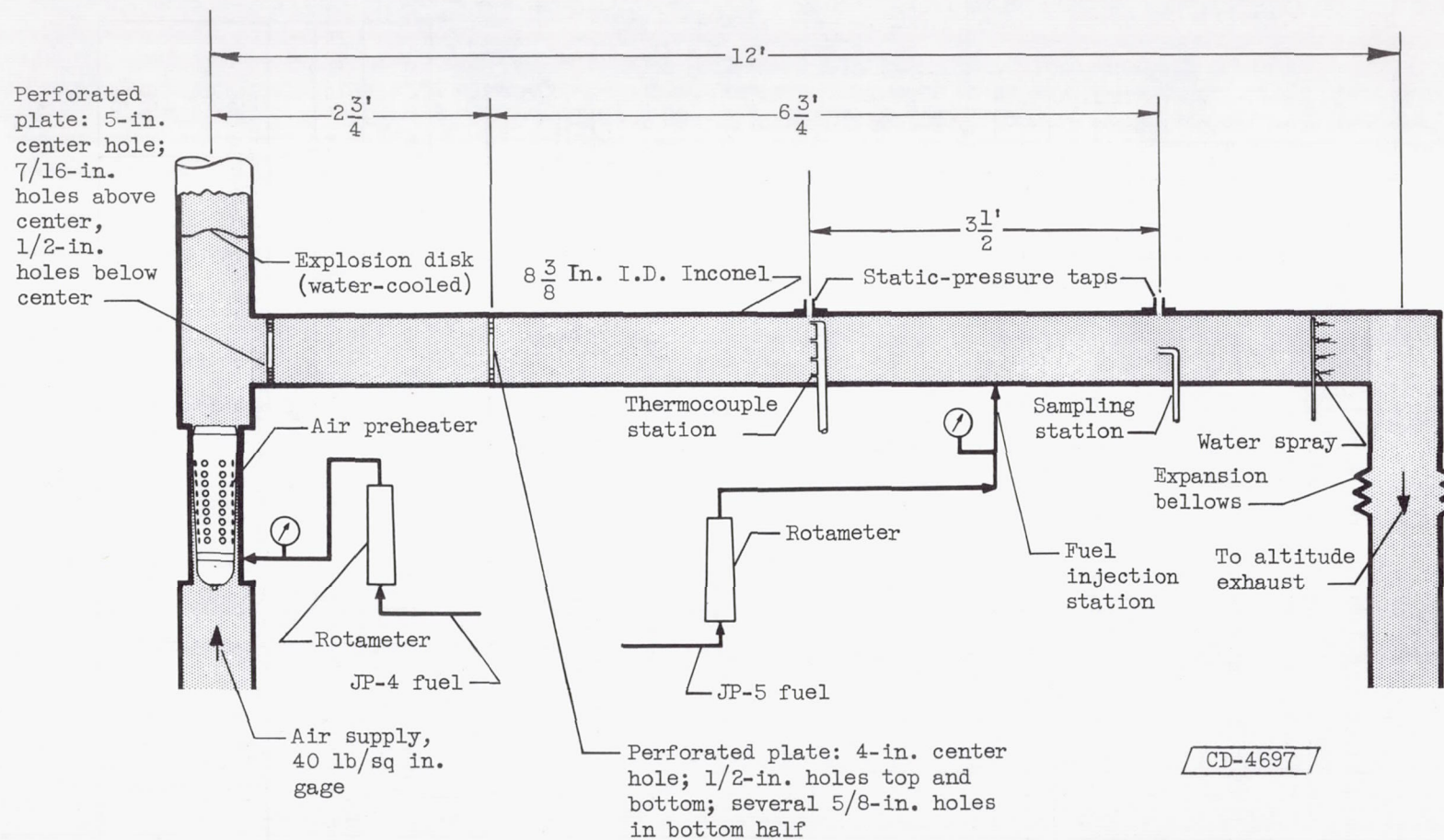

Figure 1. - Schematic drawing of test installation.

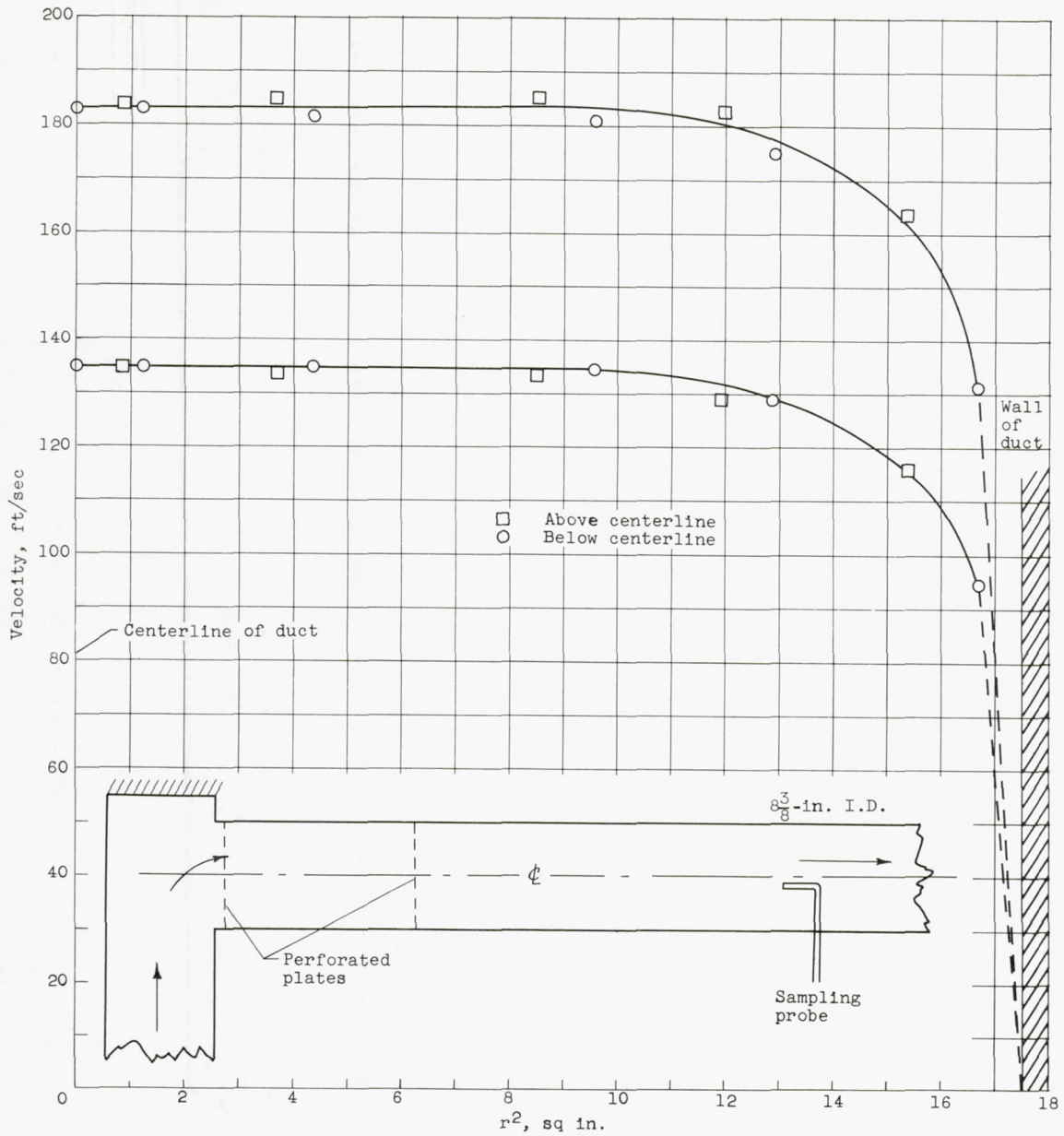

Figure 2. - Velocity profiles in test section at gas-sampling station. Air static pressure, 29.2 inches mercury absolute; air temperature, 86° F.

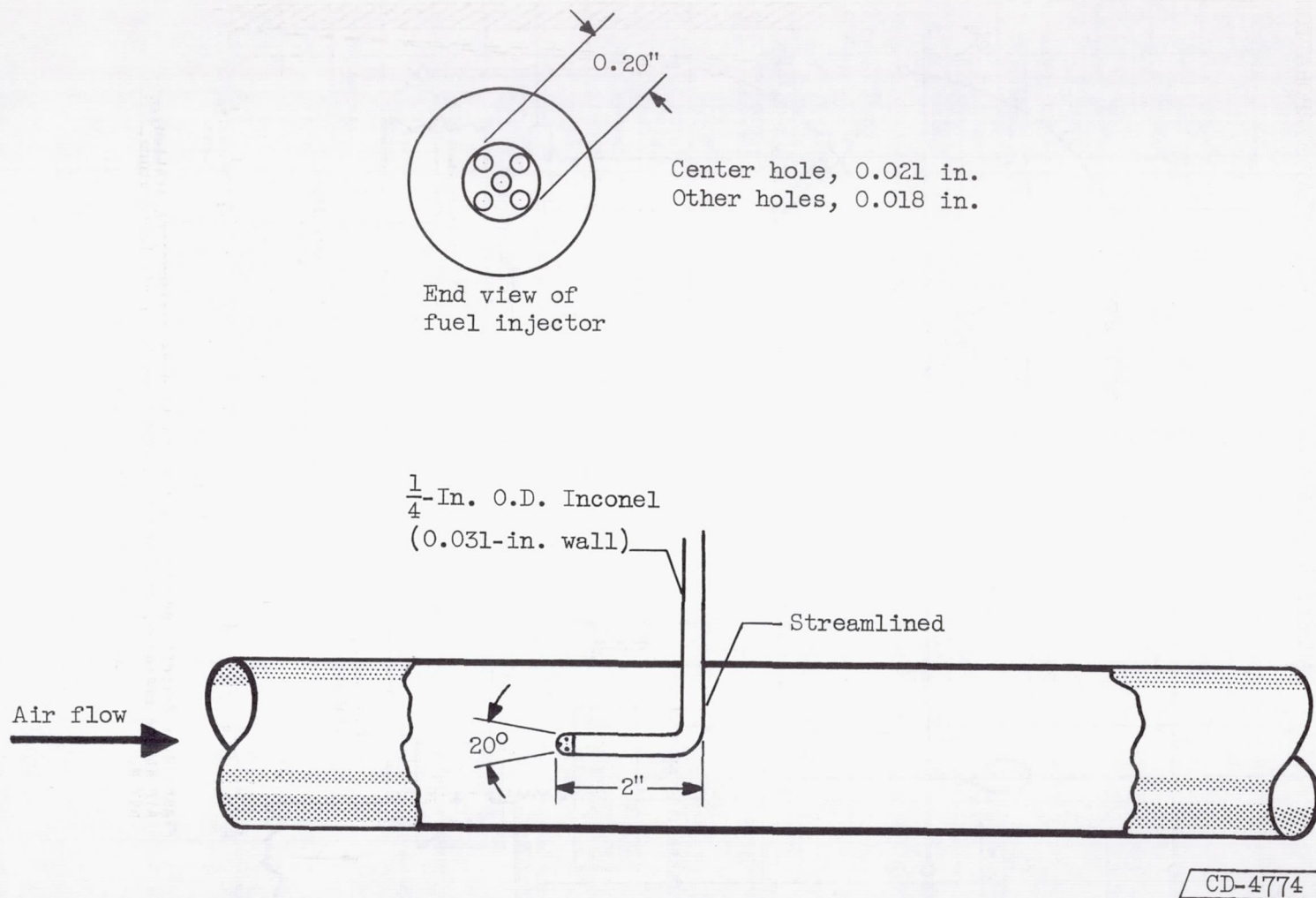
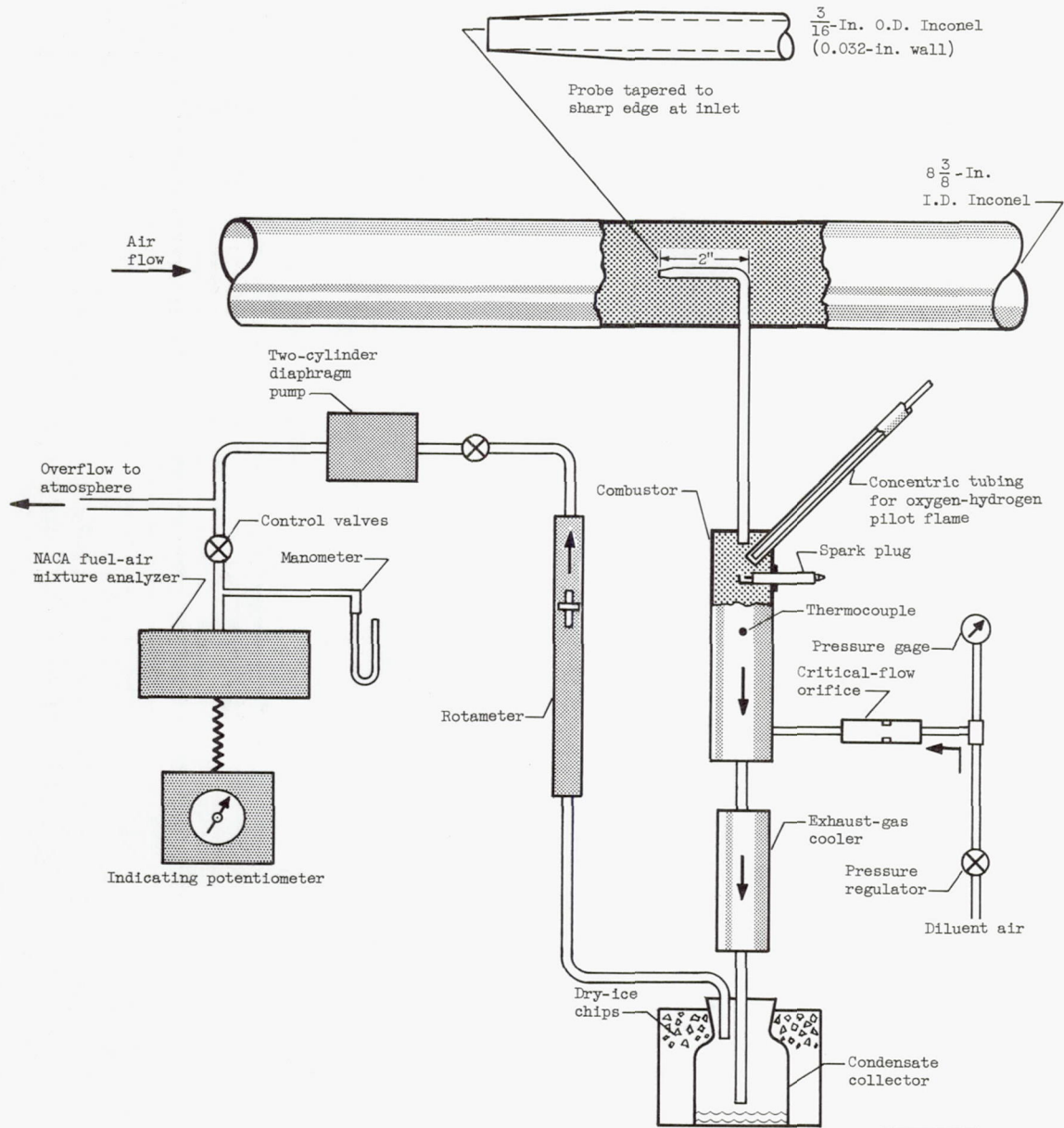
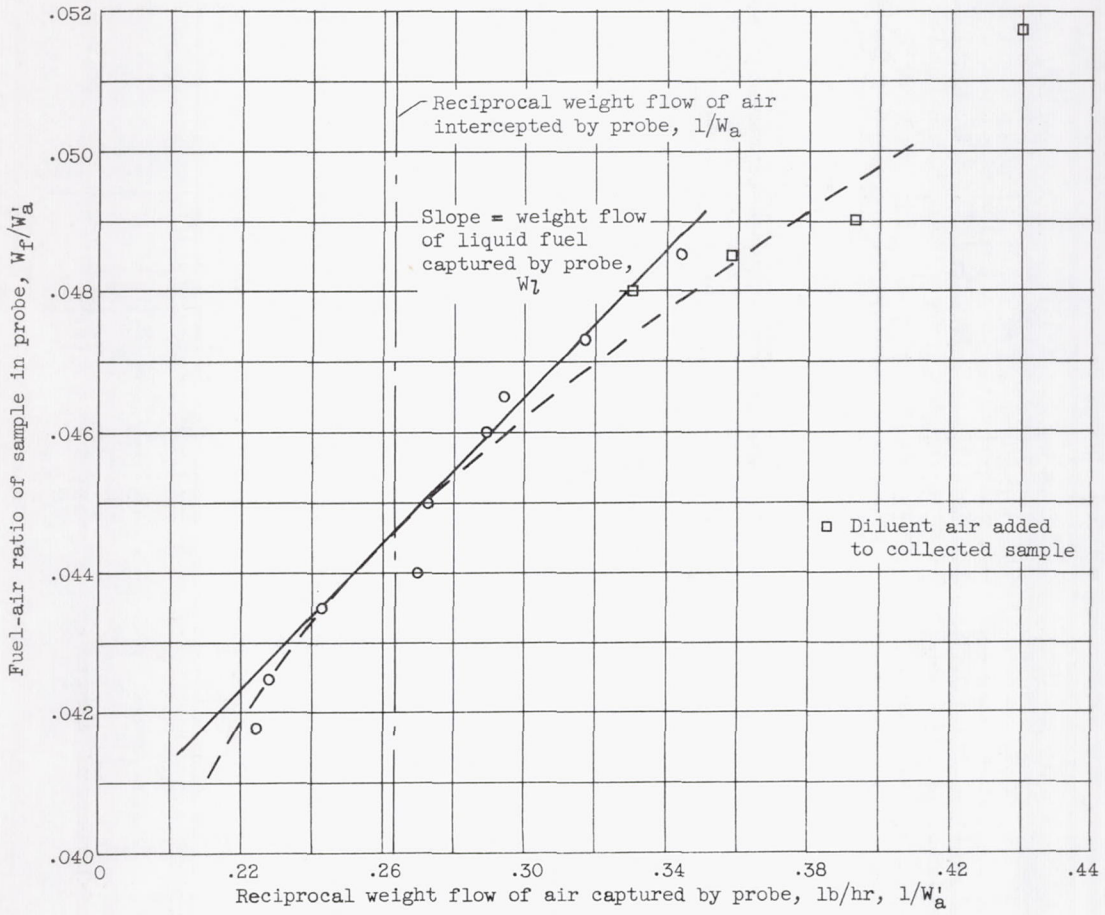

Figure 3. - Fuel injector.



CD-4773

Figure 4. - Schematic diagram of sampling system.



(a) Average data scatter.

Figure 5. - Typical data plots.

CA-3 3931

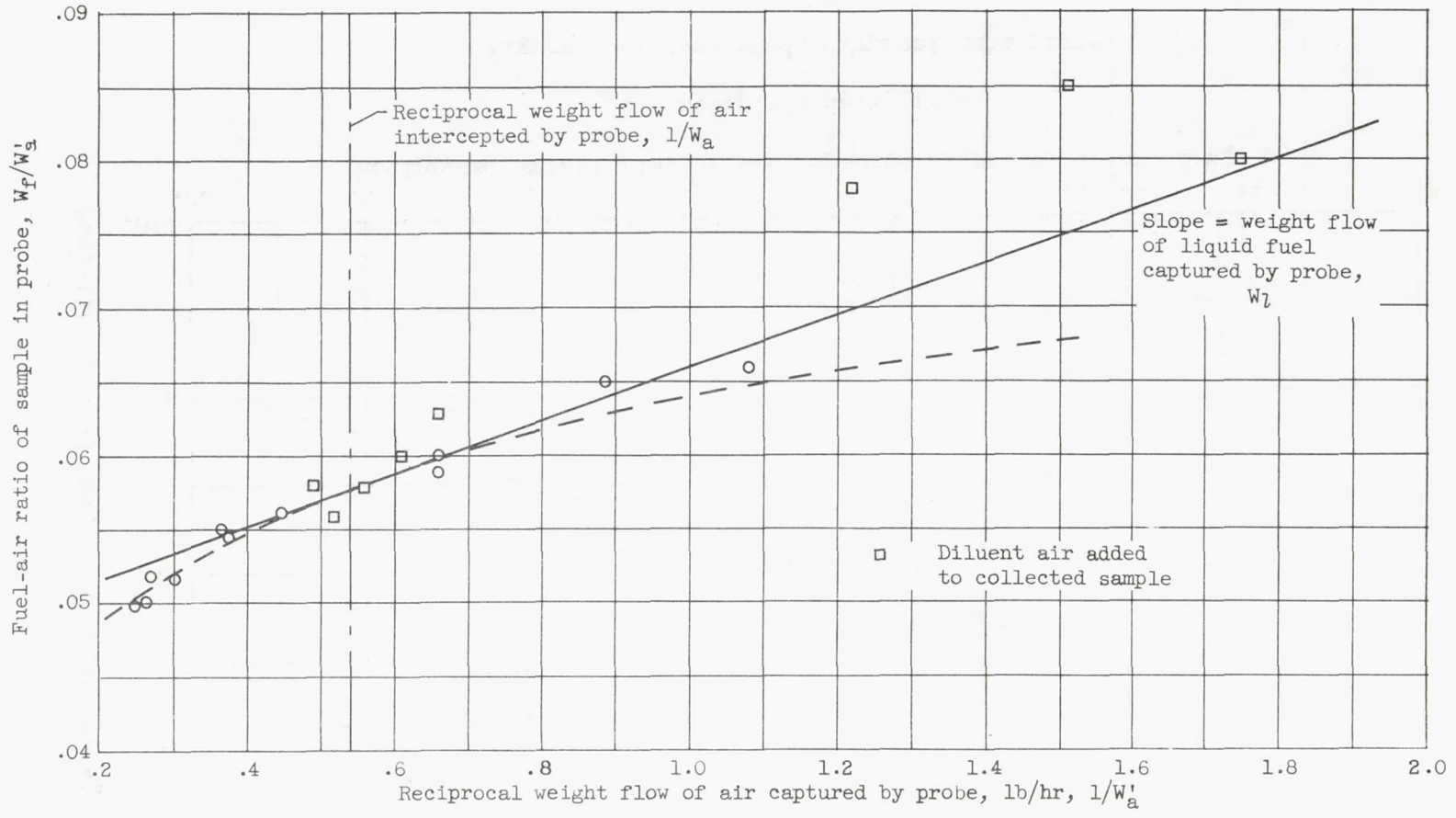

(b) Excessive data scatter (combustor effect).

Figure 5. - Continued. Typical data plots.

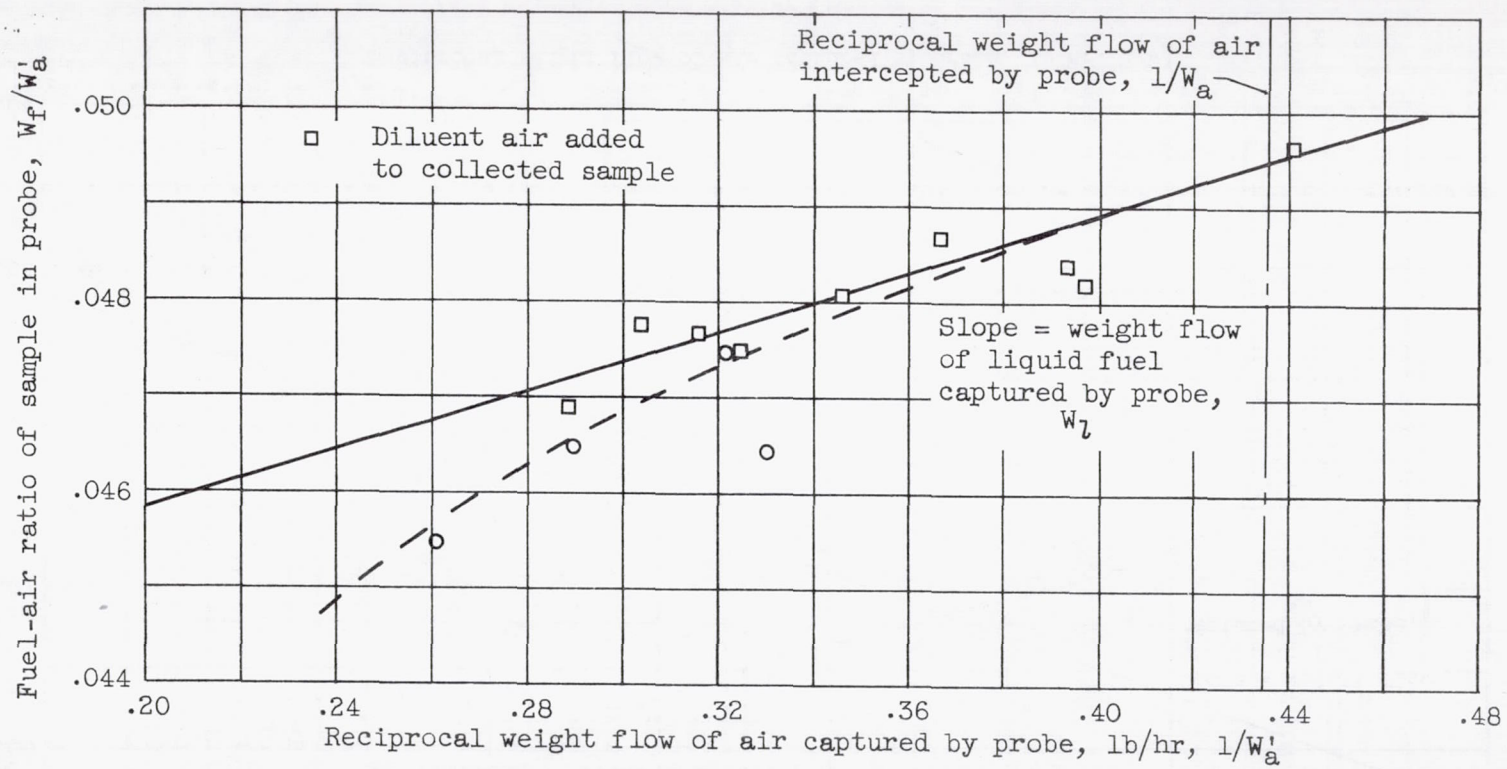

(c) Incomplete data trend.

Figure 5. - Concluded. Typical data plots.

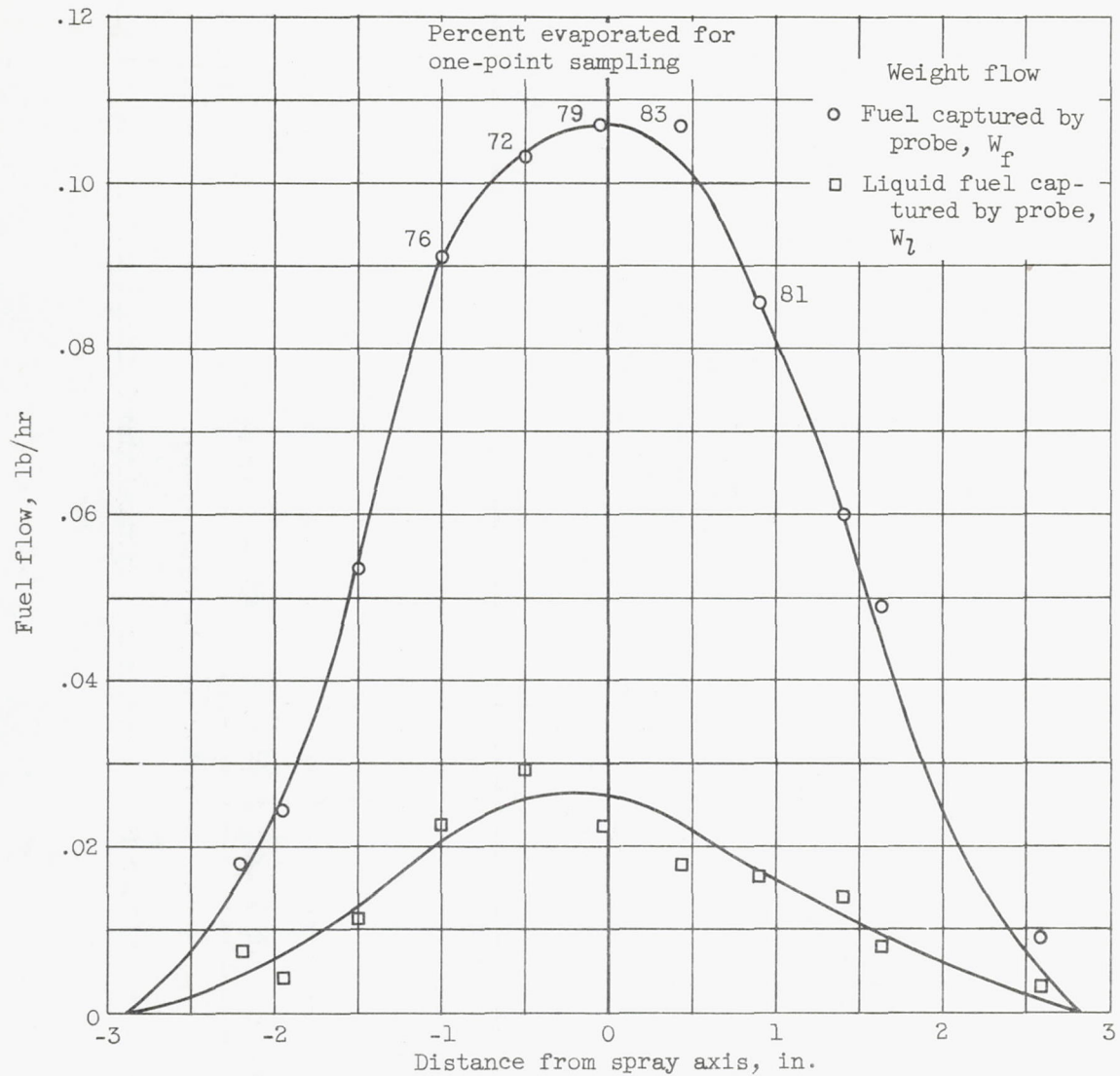
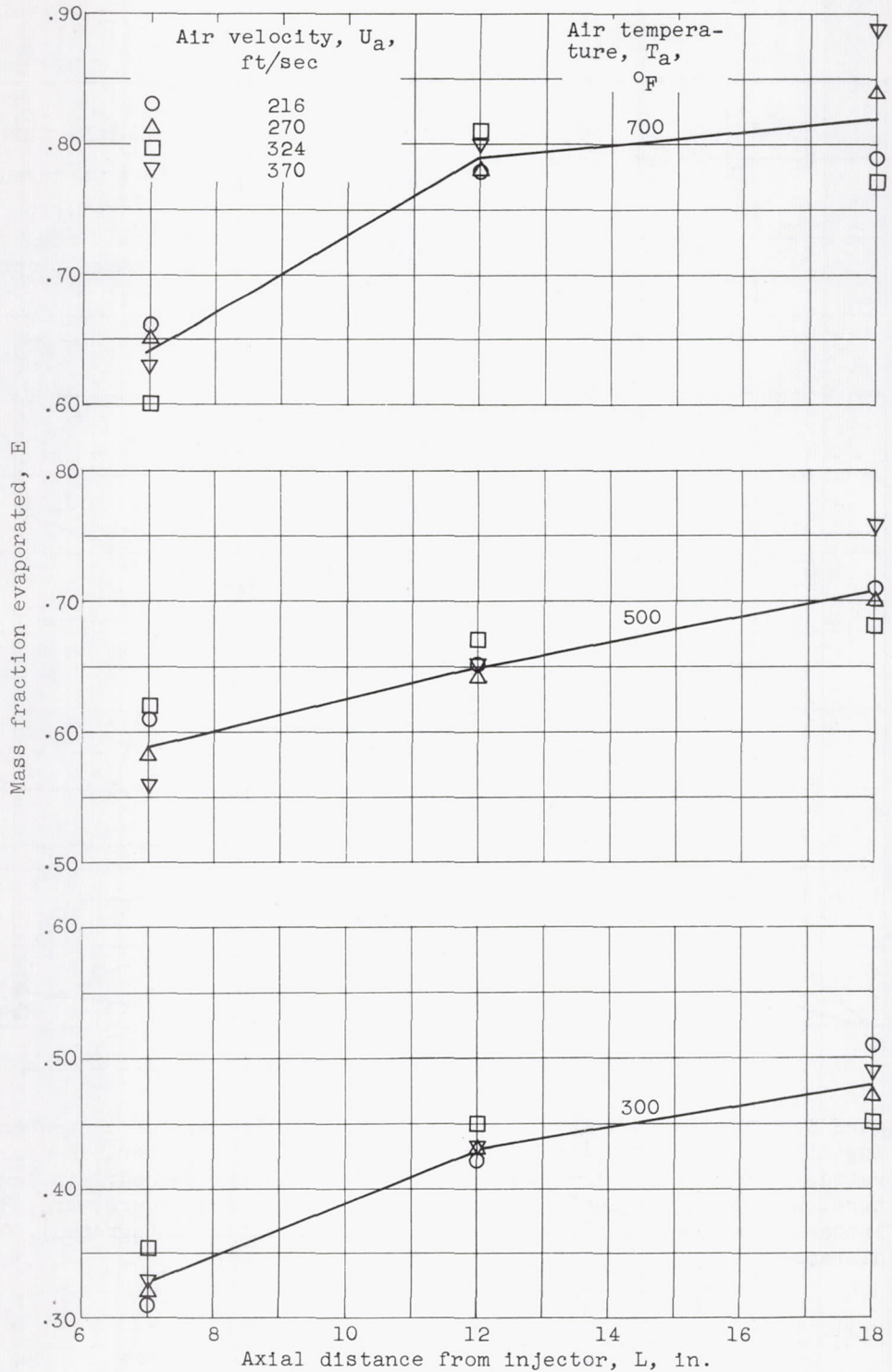

Figure 6. - Typical total- and liquid-fuel distribution for contrastream injection of JP-5 fuel from multiple-orifice fuel injector. Fuel evaporated, 75.6 percent; air-flow rate, 2.74 pounds per second; air temperature, 615° F; air velocity, 212 feet per second; static pressure, 27.5 inches of mercury absolute; over-all fuel-air ratio (integrated), 0.0147; distance from fuel injector, 12 inches.

3931



(a) Effect of sampling distance.

Figure 7. - Profiles of mass fraction of fuel spray evaporated.

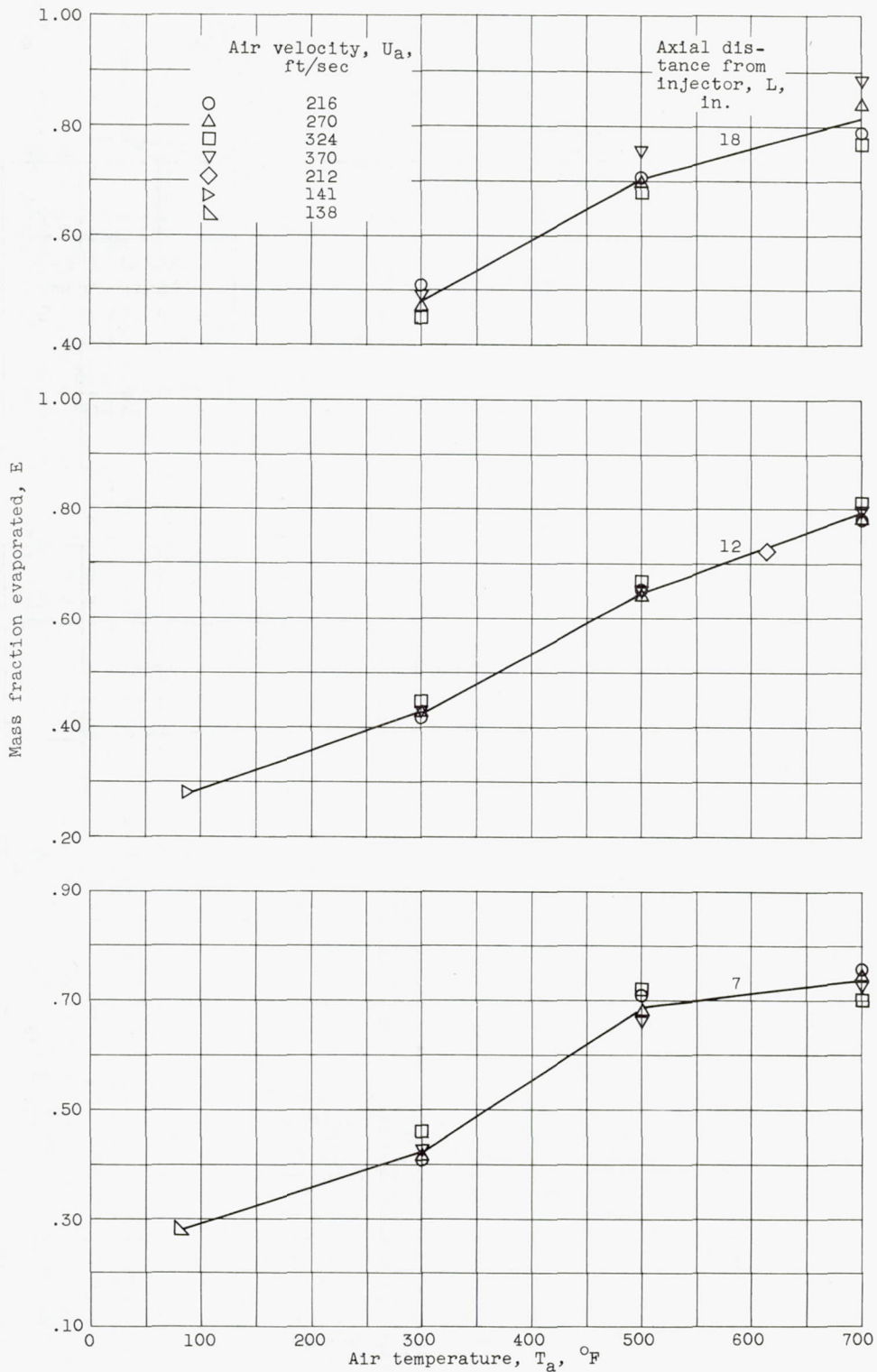

(b) Effect of air-stream temperature.

Figure 7. - Continued. Profiles of mass fraction of fuel spray evaporated.

3931

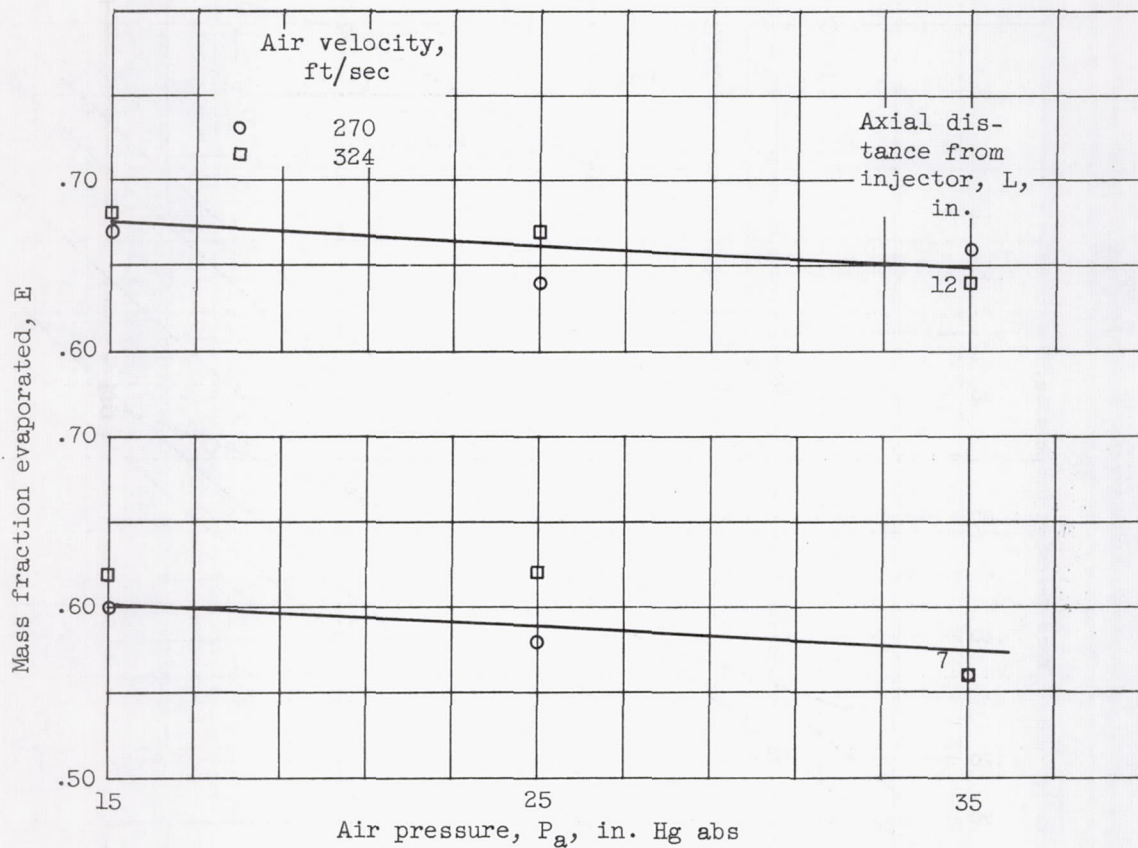

(c) Effect of air pressure.

Figure 7. Concluded. Profiles of mass fraction of fuel spray evaporated.

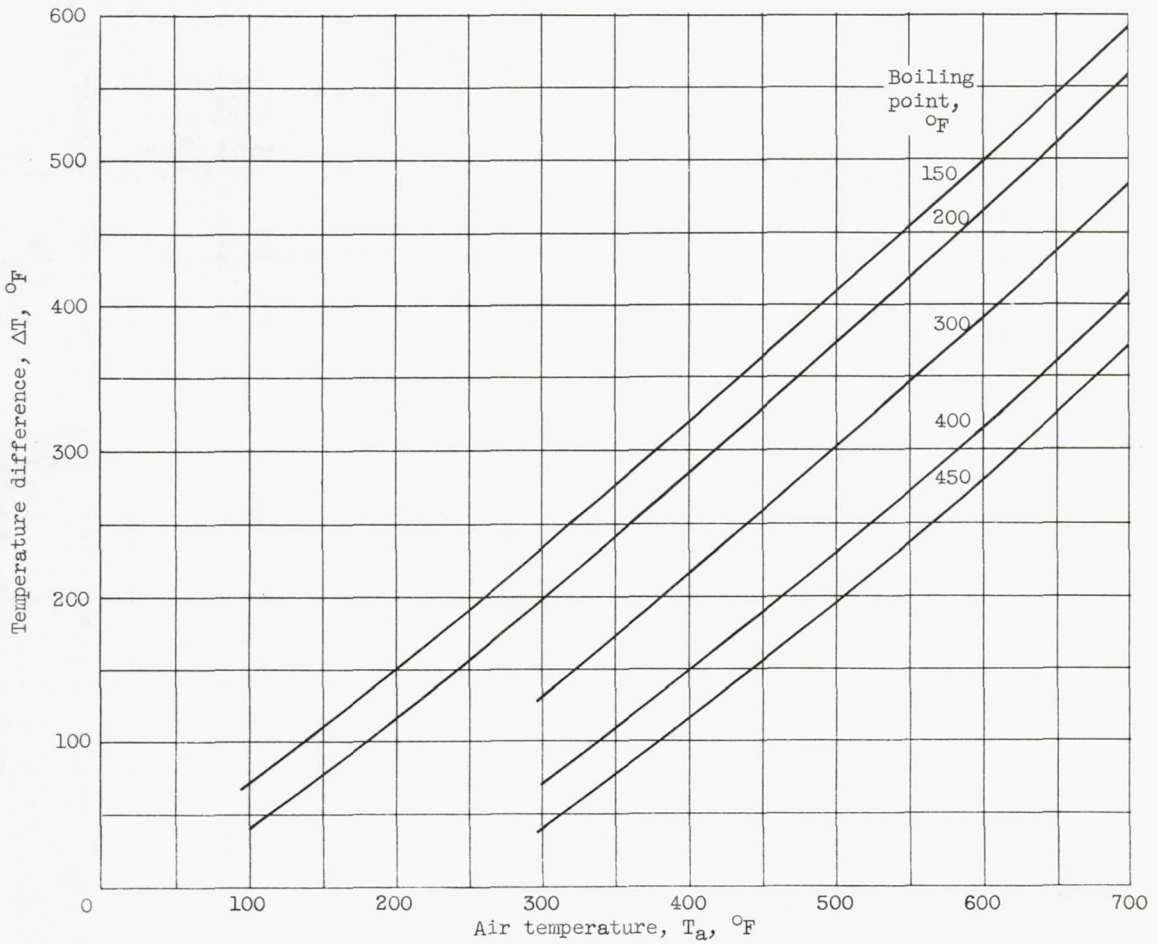
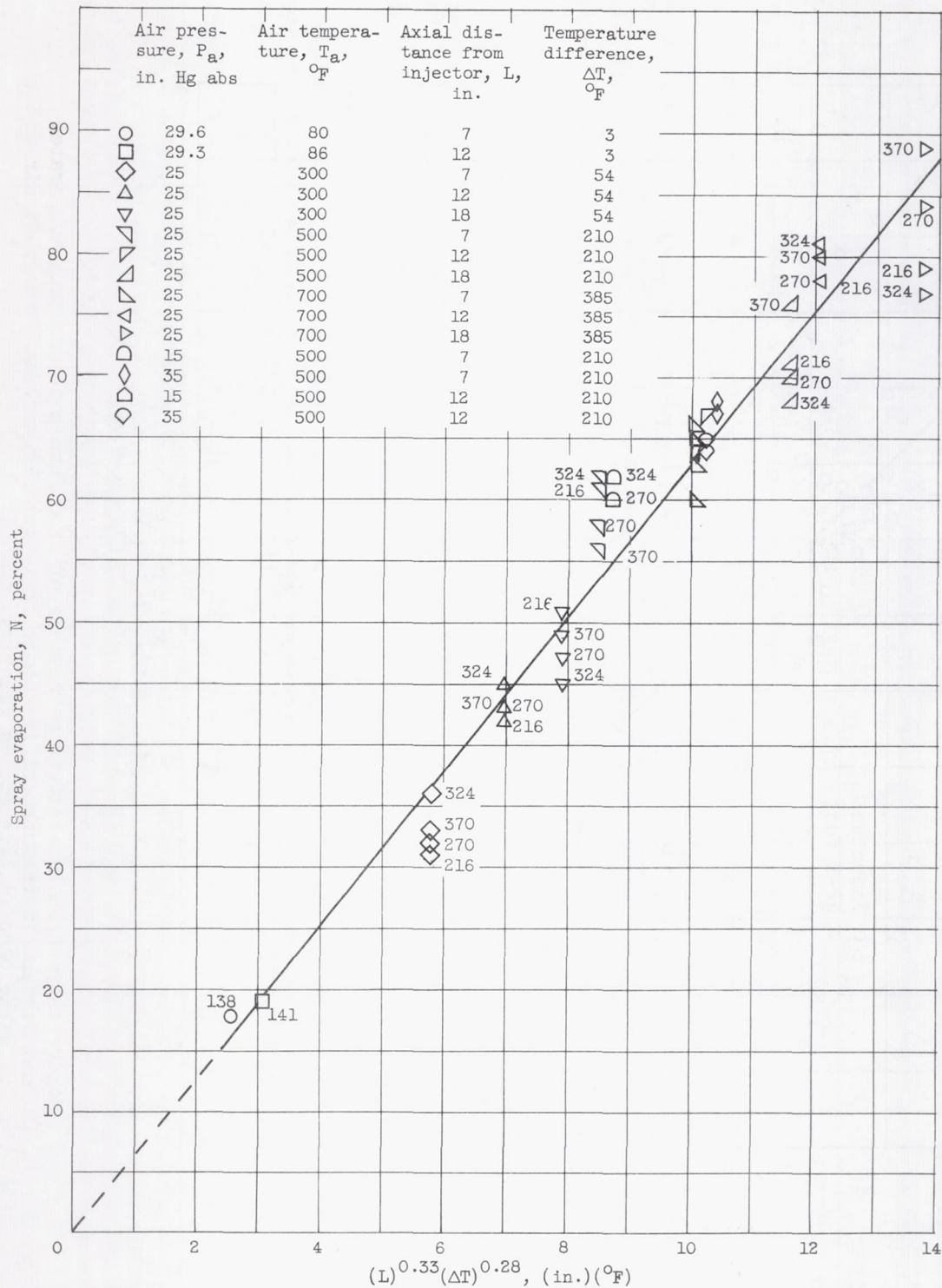

Figure 8. - Psychrometric plot of heat-transfer driving potential based on boiling-point correlation with psychrometric data (ref. 5).



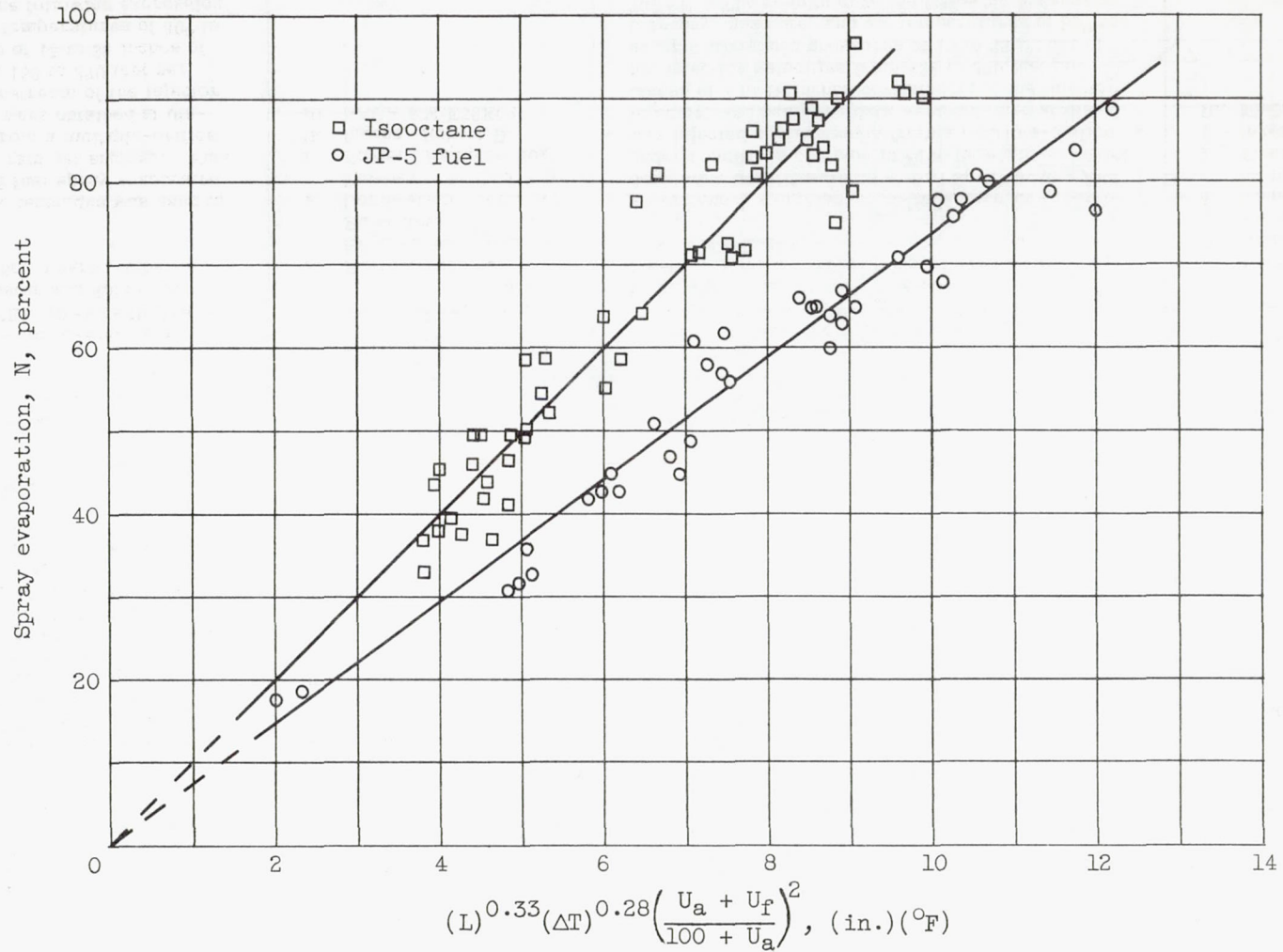

Figure 10. - Relation between percentage of JP-5 fuel and isooctane evaporated and distance downstream of injector, heat-transfer driving potential, air velocity, and fuel-injection velocity.