

Copy
RM L53B24

NACA RM L53B24



RESEARCH MEMORANDUM

MAXIMUM ALTITUDE AND MAXIMUM MACH NUMBER OBTAINED WITH
THE MODIFIED DOUGLAS D-558-II RESEARCH AIRPLANE
DURING DEMONSTRATION FLIGHTS

By Theodore E. Dahlen

Langley Aeronautical Laboratory
Hampton, Va.

~~CLASSIFICATION CHANGED~~

To UNCLASSIFIED

By authority of ✓ RN-128 *DACA Rev also effective* Date June 21, 1958

Am 78-13-58

CLASSIFIED DOCUMENT

This material contains information affecting the National Defense of the United States within the meaning of the espionage laws, Title 18, U.S.C., Secs. 793 and 794, the transmission or revelation of which in any manner to an unauthorized person is prohibited by law.

NATIONAL ADVISORY COMMITTEE FOR AERONAUTICS

WASHINGTON

April 20, 1953



NATIONAL ADVISORY COMMITTEE FOR AERONAUTICS

RESEARCH MEMORANDUM

MAXIMUM ALTITUDE AND MAXIMUM MACH NUMBER OBTAINED WITH
THE MODIFIED DOUGLAS D-558-II RESEARCH AIRPLANE
DURING DEMONSTRATION FLIGHTS

By Theodore E. Dahlen

SUMMARY

Flights to explore the high altitude and Mach number regions were made with the Douglas D-558-II research airplane in August 1951. Maximum pressure altitude recorded was 77,500 feet and the maximum geometric altitude obtained from radar data was 79,500 feet above sea level. The maximum Mach number obtained was 1.87. When a standard atmosphere is assumed, this value represents a true airspeed of 1238 miles per hour; or at the existing temperature, 3° F above standard, this represents an airspeed of 1243 miles per hour.

INTRODUCTION

The Douglas D-558-II research airplanes were procured by the Bureau of Aeronautics, Department of the Navy, and assigned to the National Advisory Committee for Aeronautics for research at transonic flight speeds. Two of these airplanes were returned to the Douglas Aircraft Company for modification. The modification of one airplane consisted of provision for air launching and of removal of the jet engine and fuel tanks which were replaced with larger rocket fuel tanks. As part of the Douglas demonstration program of the all-rocket airplane (BuAero No. 37974, NACA No. 144), several flights were made to explore the high-speed and high-altitude flight regions of this airplane at Edwards Air Force Base, Calif.

NACA instrumentation was utilized to obtain such research information as was possible during these flights. The results obtained from these instruments are presented in this paper in order to document the maximum altitude and maximum Mach number which were obtained.

~~CONFIDENTIAL~~

SYMBOLS

| | |
|-----------------------------|---|
| C_{N_A} | normal-force coefficient |
| H | altitude, ft or yd |
| M | Mach number |
| p | static pressure, lb/sq ft |
| q_c | impact pressure, lb/sq ft |
| R | radar slant range, yd |
| t | time, sec |
| θ | radar elevation angle, mils |
| ΔH | radar correction for earth curvature and atmospheric refraction, yd |
| Δp | indicated static pressure minus true static pressure, lb/sq ft |
| $\Delta\theta$ | radar-elevation-angle correction, mils |
| x | longitudinal coordinate |
| y | lateral coordinate |
| Superscript and subscripts: | |
| ' | indicated quantity |
| f | film |
| p | pressure |
| r | radar |

AIRPLANE AND INSTRUMENTATION

The Douglas D-558-II research airplane is a single-place swept-wing monoplane with a wing span of 25 feet, a wing area of 175 square feet,

and a gross weight of about 16,000 pounds. The airplane is powered by a four-cylinder Reaction Motors, Inc., rocket engine with a total thrust of 6000 pounds at sea level. The airplane carries enough fuel for about 700 cylinder-seconds of operation. A three-view drawing of the airplane is given in figure 1. A complete description of the physical characteristics of the airplane can be found in reference 1.

The static orifices in the NACA high-speed pitot static head (fig. 2) are located 3.93 body diameters ahead of the maximum diameter of the fuselage and 0.93 body diameter or $55\frac{11}{16}$ inches ahead of the apex of the nose of the airplane. The front edge of the pitot static head is $64\frac{1}{4}$ inches ahead of the apex of the nose of the fuselage. The airspeed-altitude recorder and the synchronizing recorder are located in the instrument compartment which is directly behind the pilot's cockpit. The equivalent sea-level lag time determined by the method given in reference 2 is equal to 0.047 second.

Instrumentation utilized to obtain airspeed and altitude data during these flights consisted of an SCR 584 radar unit modified to incorporate a phototheodolite unit, a four-cell airspeed-altitude recorder, and an instrument for synchronizing radar film and internal records.

DISCUSSION

Position-Error Calibration

The airspeed calibration, presented in figure 3 as variation of $\Delta p/q_c$ with Mach number, was obtained by the method of reference 3. Figure 3 shows that, after passage of the bow shock, the position error appears to be constant at a value of -0.006. The scatter of the points about this value is about the same as the estimated uncertainty of the calibration. These results are consistent within the estimated maximum uncertainty of the data with calibrations of similar airspeed heads obtained both in flight and in wind-tunnel tests where comparable speeds were attained.

On the basis of the above, the position error is assumed constant at -0.006 in the remainder of this paper. This value is considered to be reliable within about ± 0.01 .

Determination of Maximum Altitude

The flight which resulted in the maximum altitude obtained was made on August 15, 1951. A time history of pressure altitude, Mach number, and normal-force coefficient from drop to maximum altitude is given in figure 4. The altitude reached by the airplane was determined by two methods, namely, pressure recording instruments and radar tracking.

The values used in the computation of maximum pressure altitude are given in table I. The values of pressure altitude for a given pressure were taken from tables in reference 4. A correction of $-0.006 \Delta p/q_c'$, obtained from the airspeed calibration, was applied to the indicated value of static pressure. The maximum pressure altitude reached was 77,500 feet.

The maximum scatter of data points about the curve in the instrument calibration is less than ± 0.8 pound per square foot. The instrument is calibrated at various temperatures and has a temperature-sensing element so that the maximum probable instrument error is about ± 0.8 pound per square foot. The estimated nominal maximum uncertainty of the airspeed calibration (fig. 3) is believed to be approximately $\pm 0.01 \Delta p/q_c'$. The value of q_c' at the maximum altitude was 124.0 pounds per square foot; this value yields an estimated calibration error of ± 1.24 pounds per square foot and an estimated maximum probable error of about ± 1.48 pounds per square foot which at a pressure altitude of 77,500 feet is equivalent to approximately ± 500 feet.

The determination of maximum geometric altitude is shown in table II. The maximum altitude above the radar antenna was 77,210 feet and the geometric altitude above sea level was 79,500 feet.

The maximum error in radar slant range and radar elevation angle is approximately ± 60 feet and ± 0.3 mil, respectively. For the values of range and elevation angle used, corrected for zero shift, beacon delay, earth curvature and atmospheric refraction, these values result in a maximum probable error in radar altitude of about ± 65 feet.

Determination of Maximum Mach Number

The flight which resulted in the highest Mach number obtained was made on August 7, 1951. A time history of pressure altitude, Mach number, and normal-force coefficient from drop to maximum Mach number is given in figure 5.

The computations of maximum Mach number are given in table III and the maximum Mach number recorded was 1.87. The accuracy of the airspeed-altitude system and the estimated uncertainty of the calibration results in a maximum probable uncertainty in Mach number of about ± 0.05 .

Since there was no radiosonde balloon data at high altitudes on the day of the flight to maximum Mach number, it was necessary to compute the free-air temperature from the stagnation temperature probe on the airplane. This computation was made by the method described in reference 5 and results in a value of free-air temperature of 3° F above standard.

The maximum airspeed obtained by assuming a standard atmosphere with the speed of sound equal to 662 miles per hour was 1238 miles per hour ± 33 miles per hour. At a temperature 3° F above standard, the maximum airspeed was 1243 miles per hour ± 33 miles per hour.

CONCLUSIONS

During flights to explore the high-speed and high-altitude flight regions of the Douglas D-558-II research airplane the following values of maximum Mach number and altitude and their estimated nominal error were obtained:

1. Maximum pressure altitude obtained, based on NACA standard atmosphere, was 77,500 feet ± 500 feet.

2. Maximum geometric altitude above sea level reached was 79,500 feet ± 65 feet.

3. The maximum Mach number was 1.87 ± 0.05 at a pressure altitude of 67,300 feet.

4. Based on a standard atmosphere, the maximum speed was 1238 miles per hour ± 33 miles per hour. The variation from standard temperature, based on computations from stagnation temperature, was 3° F; this variation would result in a maximum airspeed of 1243 miles per hour ± 33 miles per hour.

Langley Aeronautical Laboratory,
National Advisory Committee for Aeronautics,
Langley Field, Va.

REFERENCES

1. Ankenbruck, Herman O., and Dahlen, Theodore E.: Some Measurements of Flying Qualities of a Douglas D-558-II Research Airplane During Flights to Supersonic Speeds. NACA RM L53A06, 1953.
2. Huston, Wilber B.: Accuracy of Airspeed Measurements and Flight Calibration Procedures. NACA Rep. 919, 1948. (Supersedes NACA TN 1605.)
3. Zalovcik, John A.: A Radar Method of Calibrating Airspeed Installations on Airplanes in Maneuvers at High Altitudes and at Transonic and Supersonic Speeds. NACA Rep. 985, 1950. (Supersedes NACA TN 1979.)
4. Aiken, William S., Jr.: Standard Nomenclature for Airspeeds With Tables and Charts for Use in Calculation of Airspeed. NACA Rep. 837, 1946. (Supersedes NACA TN 1120.)
5. Jones, Ira P., Jr.: Measurements of Aerodynamic Heating Obtained During Demonstration Flight Tests of the Douglas D-558-II Airplane. NACA RM L52I26a, 1952.

TABLE I

DETERMINATION OF MAXIMUM PRESSURE ALTITUDE

| Time, sec | q_c' , lb/sq ft | p' , lb/sq ft | q_c'/p' | M' | Δp , lb/sq ft | p , lb/sq ft | H_p , ft |
|--------------|----------------------|--------------------|-----------|-------|--------------------------|-------------------|------------|
| 196 | 124.5 | 65.0 | 1.9154 | 1.361 | -0.8 | 65.8 | 77,362 |
| 197 | 124.0 | 64.8 | 1.9136 | 1.361 | -.7 | 65.5 | 77,456 |
| 198 | 124.0 | 64.8 | 1.9136 | 1.361 | -.7 | 65.5 | 77,456 |
| 199 | 124.0 | 64.8 | 1.9136 | 1.361 | -.7 | 65.5 | 77,456 |
| 200 | 124.0 | 65.0 | 1.9077 | 1.359 | -.7 | 65.7 | 77,393 |

NACA

TABLE II
DETERMINATION OF MAXIMUM GEOMETRIC ALTITUDE

| Frame number | R_f , yd | R, yd | θ_f , mils | $\Delta\theta_f$, mils | θ , mils (a) |
|--------------|------------|--------|-------------------|-------------------------|---------------------|
| 400 | 37,330 | 36,860 | 788.8 | -1.9 | 785.5 |

| $\sin \theta$ | H' , yd (b) | ΔH , yd | H_r , yd | H_r , ft | H, ft |
|---------------|---------------|-----------------|------------|------------|--------|
| 0.69697 | 25,690 | 46 | 25,736 | 77,208 | 79,494 |

^a $\theta = \theta_f + \Delta\theta_f - 1.4.$

^b $H' = R \sin \theta$



TABLE III

MAXIMUM MACH NUMBER COMPUTATION

| Time, sec | q_c' , lb/sq ft | p' , lb/sq ft | q_c'/p' | M' |
|--------------|----------------------|--------------------|-----------|-------|
| 179.0 | 434.5 | 106.3 | 4.0875 | 1.889 |
| 179.2 | 435.5 | 106.4 | 4.0930 | 1.890 |
| 179.4 | 436.0 | 106.4 | 4.0977 | 1.891 |
| 179.6 | 437.0 | 106.4 | 4.1071 | 1.893 |
| 179.8 | 437.0 | 106.4 | 4.1071 | 1.893 |
| 180.0 | 437.0 | 106.7 | 4.0956 | 1.890 |

| $\Delta p'$ lb/sq ft | p , lb/sq ft | q_c' lb/sq ft | q_c/p | M |
|-------------------------|-------------------|--------------------|---------|-------|
| -2.6 | 108.9 | 431.9 | 3.9660 | 1.863 |
| -2.6 | 109.0 | 432.9 | 3.9716 | 1.865 |
| -2.6 | 109.0 | 433.4 | 3.9761 | 1.865 |
| -2.6 | 109.0 | 434.4 | 3.9853 | 1.867 |
| -2.6 | 109.0 | 434.4 | 3.9853 | 1.867 |
| -2.6 | 109.3 | 434.4 | 3.9744 | 1.865 |

 NACA



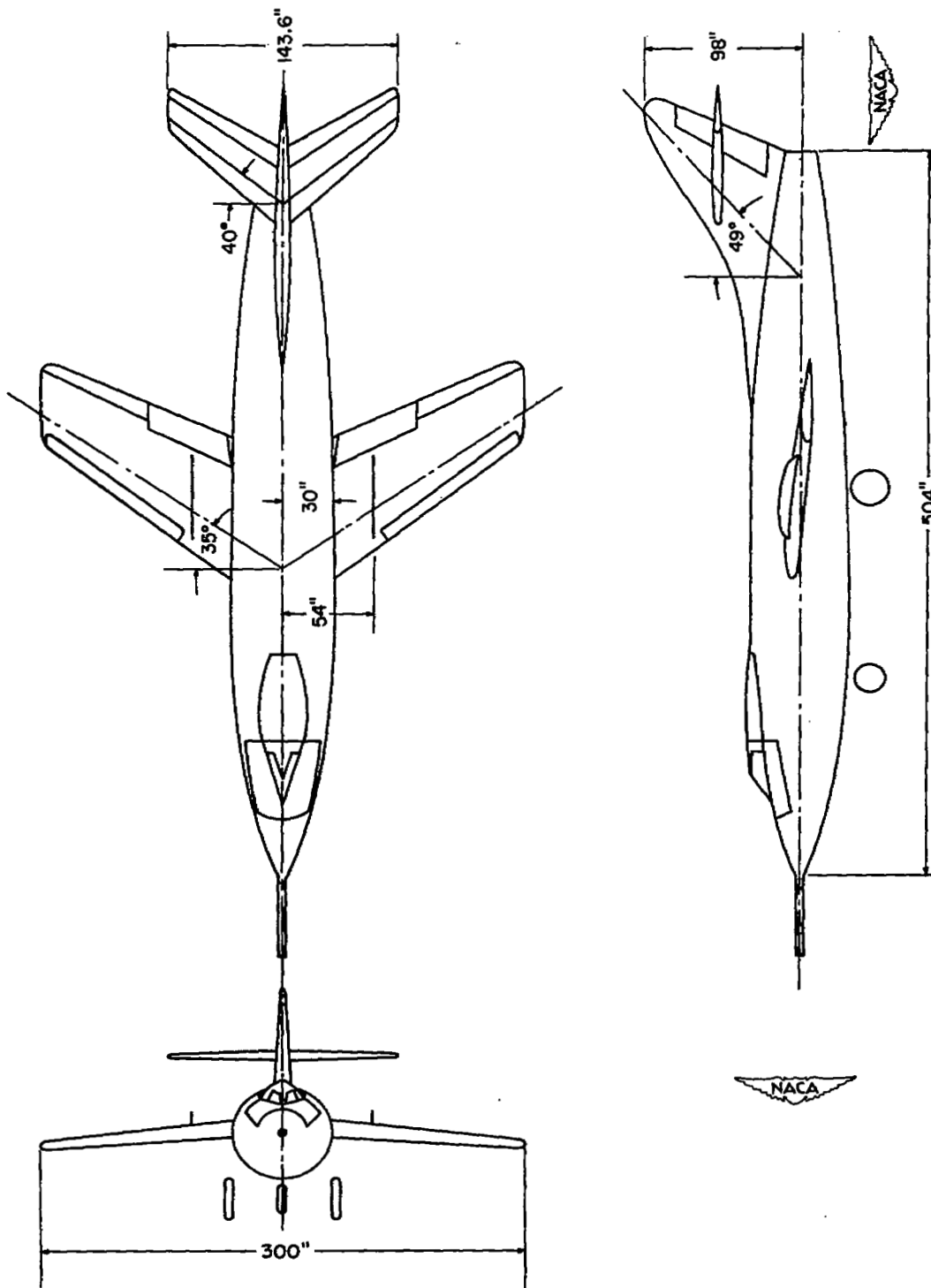

Figure 1.- Three-view drawing of the Douglas D-558-II research airplane.

| Table of ordinates | | | |
|--------------------|--------|------|--------|
| x | y | x | y |
| 0.10 | 0.1837 | 1.40 | 0.3838 |
| .20 | .2034 | 1.50 | .3931 |
| .30 | .2233 | 1.60 | .4014 |
| .40 | .2423 | 1.70 | .4090 |
| .50 | .2605 | 1.80 | .4156 |
| .60 | .2777 | 1.90 | .4213 |
| .70 | .2940 | 2.00 | .4262 |
| .80 | .3095 | 2.10 | .4302 |
| .90 | .3241 | 2.20 | .4333 |
| 1.00 | .3378 | 2.30 | .4356 |
| 1.10 | .3506 | 2.40 | .4369 |
| 1.20 | .3626 | 2.50 | .4375 |
| 1.30 | .3736 | 2.60 | .4375 |

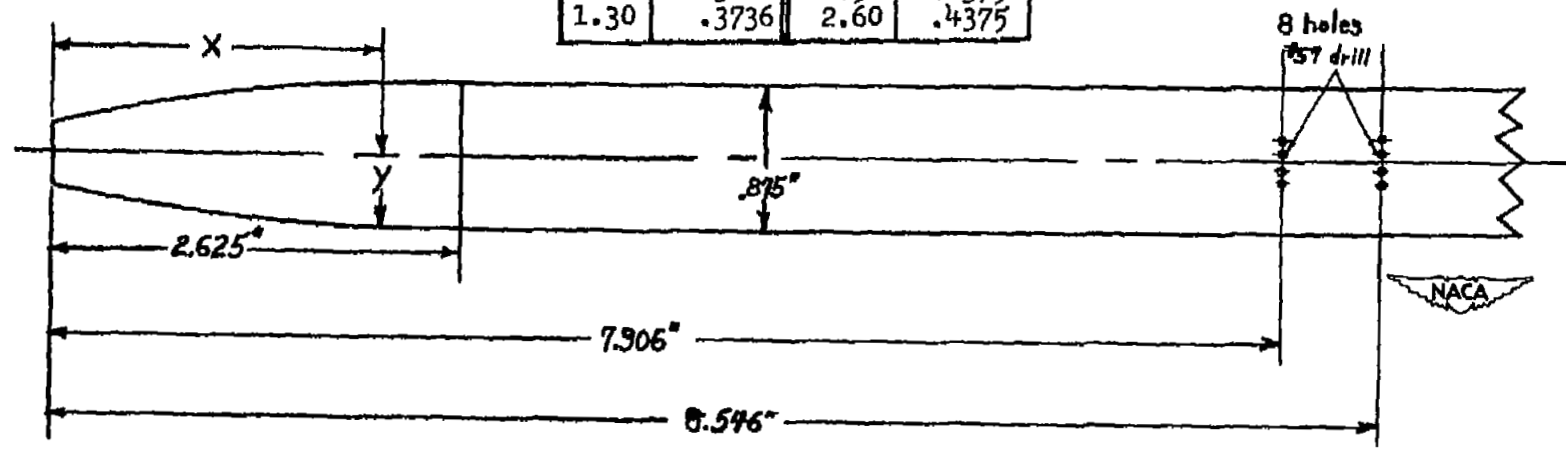

Figure 2.- Pitot static head.

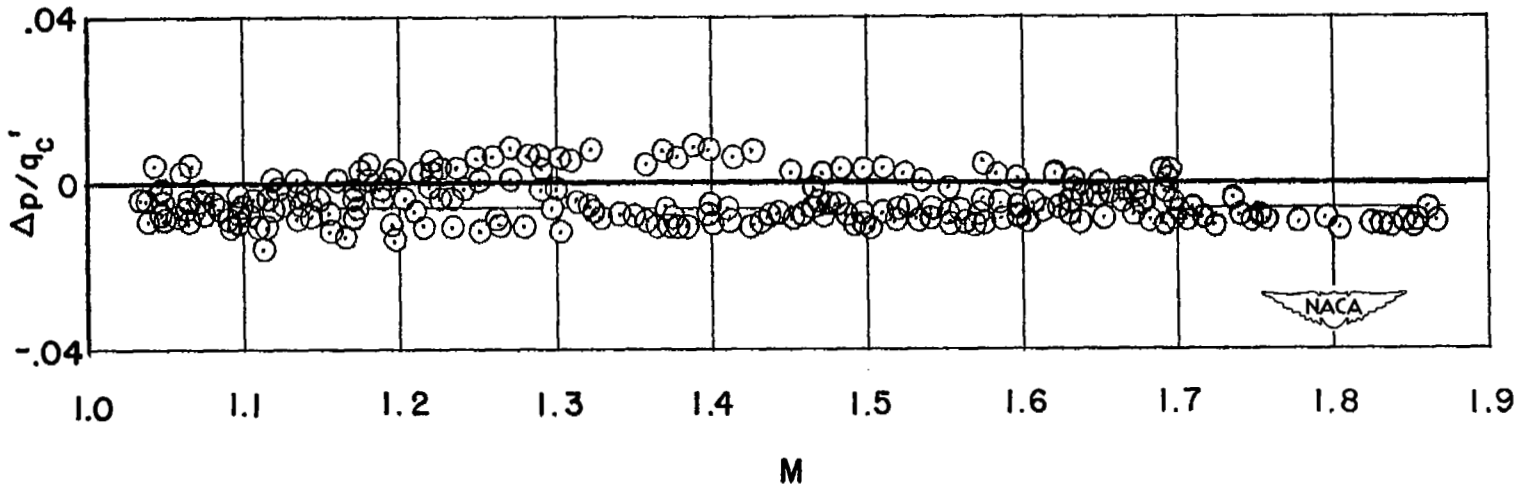

Figure 3.- Position-error calibration.

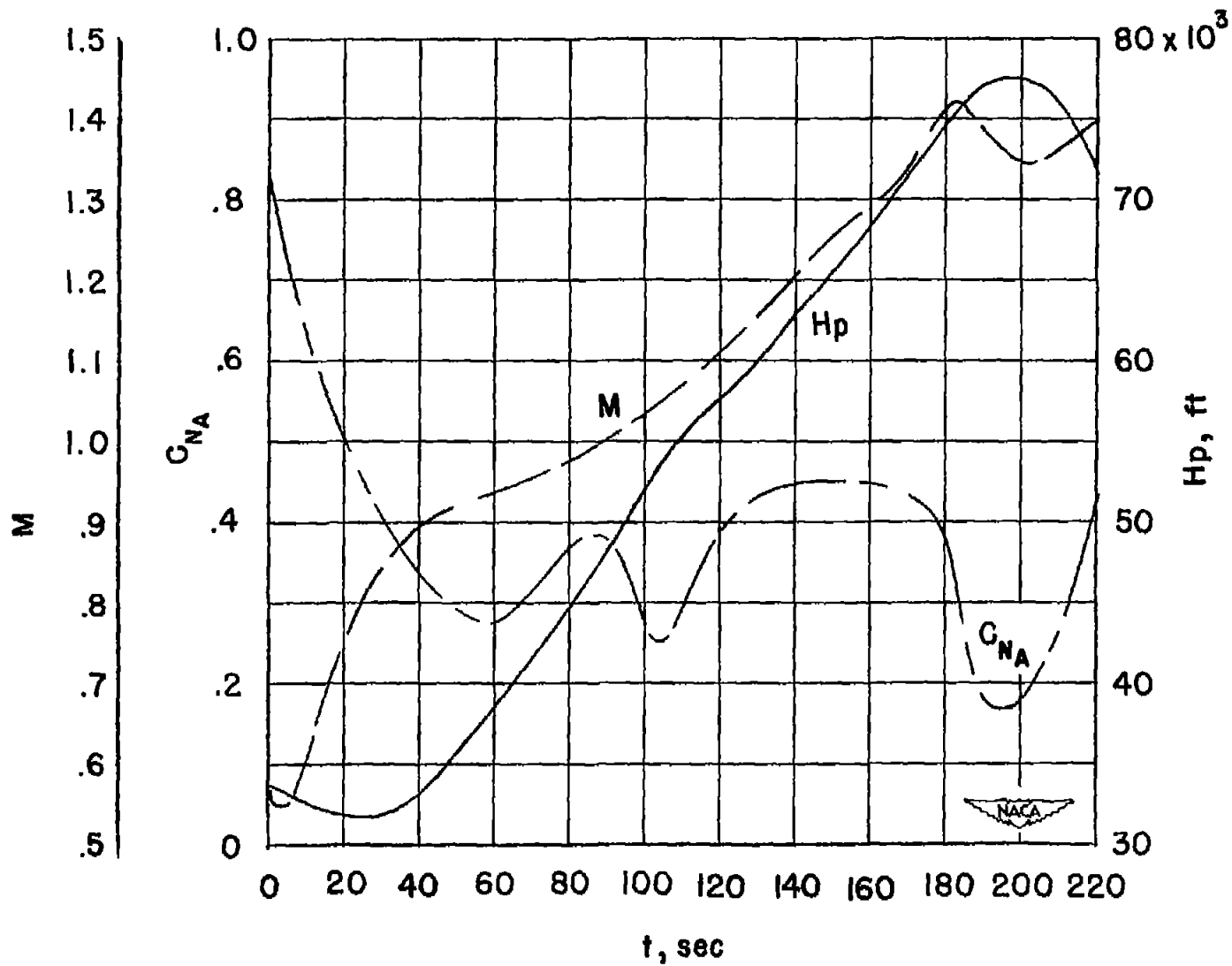

Figure 4.- Time history of flight to maximum altitude.

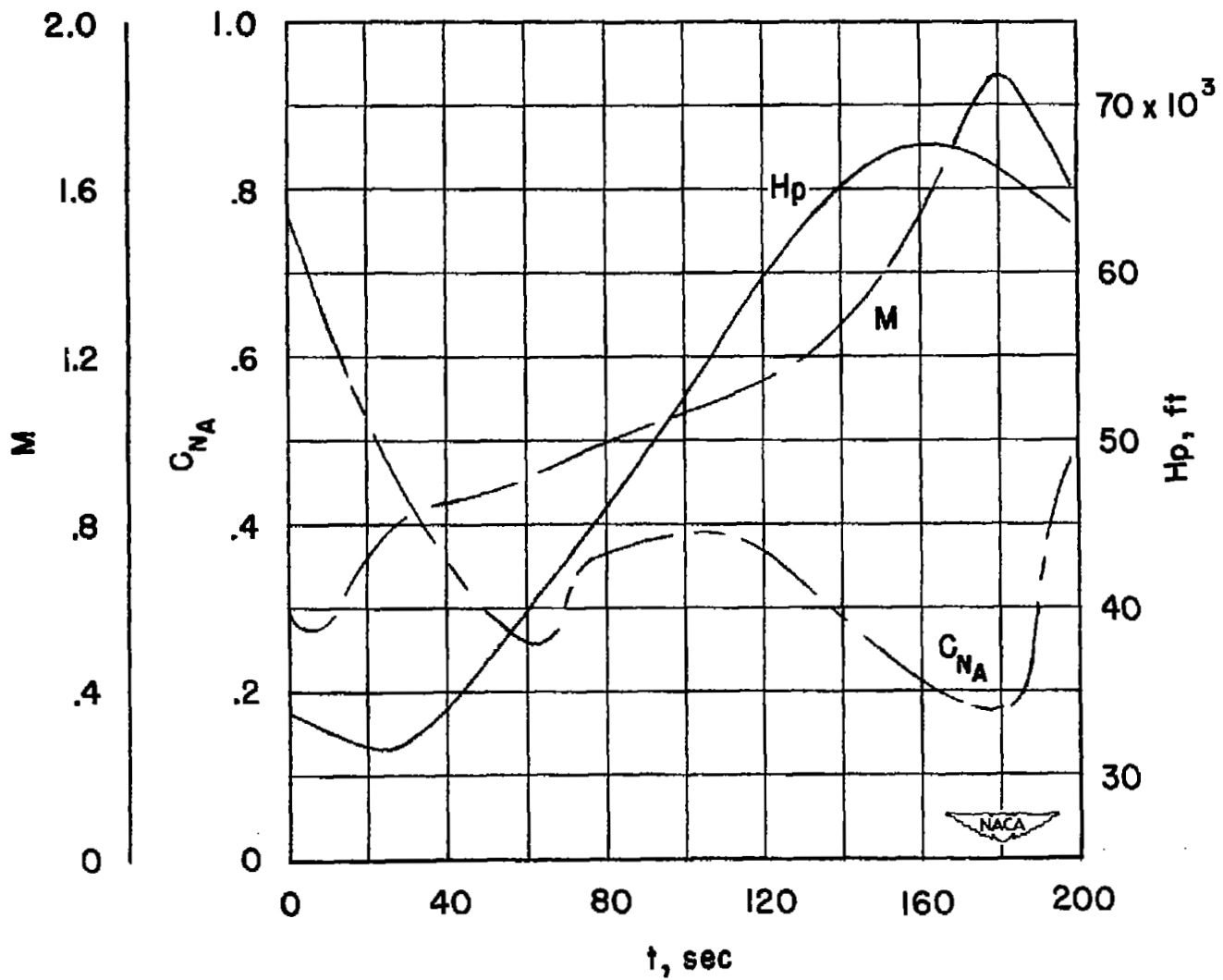

Figure 5.- Time history of flight to maximum Mach number.

SECURITY

NASA Technical Library



3 1176 01437 5704

ATION

~~8/11/59~~

~~CONFIDENTIAL~~