

RESEARCH MEMORANDUM

MACH NUMBER MEASUREMENTS AND CALIBRATIONS DURING FLIGHT
AT HIGH SPEEDS AND AT HIGH ALTITUDES INCLUDING
DATA FOR THE D-558-II RESEARCH AIRPLANE

By Cyril D. Brunn and Wendell H. Stillwell

High-Speed Flight Station
Edwards, Calif.

**NATIONAL ADVISORY COMMITTEE
FOR AERONAUTICS
WASHINGTON**

March 12, 1956
Declassified June 24, 1958

NATIONAL ADVISORY COMMITTEE FOR AERONAUTICS

RESEARCH MEMORANDUM

MACH NUMBER MEASUREMENTS AND CALIBRATIONS DURING FLIGHT

AT HIGH SPEEDS AND AT HIGH ALTITUDES INCLUDING

DATA FOR THE D-558-II RESEARCH AIRPLANE

By Cyril D. Brunn and Wendell H. Stillwell

SUMMARY

The accuracies associated with Mach number measurements based on pitot-static pressures are evaluated with respect to the individual errors of the measuring instruments, recording instruments, position-error calibrations, and time lag. The methods and instruments employed at the National Advisory Committee for Aeronautics High-Speed Flight Station at Edwards, Calif. are used to illustrate the magnitudes of the errors associated with Mach number measurements at supersonic speeds and at high altitudes. It is indicated that the largest Mach number errors are caused by inaccuracies of position-error calibrations and that an overall accuracy of 1 percent will be difficult to attain.

Data are presented for two modified methods of the basic radar photodolite method of position-error calibration. These methods are based on radiosonde measurements of pressure and temperature and are not dependent on a fly-by or low-level position-error calibration.

The practical application of the instruments and methods employed by the NACA is given for the maximum altitude and maximum Mach number flights of the D-558-II research airplane in which a maximum altitude of 83,235 feet, a maximum Mach number of 2.005, and a maximum true airspeed of 1,291 miles per hour were attained.

INTRODUCTION

The accurate determination of Mach number is of fundamental importance in the flight testing of high-speed aircraft. The basic method normally employed to determine Mach number during flight is the measurement of total and static pressures. A review of the various types of instruments and methods and the associated accuracies that have been

used is presented in reference 1. However, the flight envelope of many aircraft has extended past the altitude and Mach number limits of reference 1 and interest has been shown in data concerning the methods and accuracies of Mach number measurements to higher speeds and altitudes.

Instrumentation and methods have been developed by the NACA for particular application to high-altitude, high Mach number flight. Considerable experience has been gained in using these methods and instrumentation at altitudes up to about 80,000 feet and at Mach numbers up to about 2.0. Consideration is also being given to the instrumentation and methods for flights to higher altitudes and Mach numbers. A review is made of the methods and instrumentation now employed at the NACA High-Speed Flight Station to illustrate the errors and accuracies associated with Mach number measurements at high speeds and altitudes. Although the accuracies are for specific instruments and methods, the procedures may be applied to aid in the evaluation of Mach number accuracies of other installations.

Computations are presented for the accuracies associated with Mach number measurements at altitudes from 40,000 feet to 140,000 feet and at Mach numbers from 1.0 to 3.0. An example is given of the practical application of these methods for U. S. Navy and NACA exploratory flights to an altitude of about 83,000 feet and to a Mach number of about 2.0. These flights utilized the Douglas D-558-II research airplane equipped with standard NACA instrumentation.

SYMBOLS

a_n	normal acceleration, g units
C_{NA}	airplane normal-force coefficient, $\frac{a_n W}{qS}$
g	acceleration due to gravity, ft/sec ²
H	total pressure, $q_c + p$, lb/sq ft
h	absolute altitude, ft
h_p	pressure altitude, ft
h_R	altitude above radar antenna, ft
K	temperature probe recovery factor

M	true Mach number
M'	measured Mach number
p	free-stream static pressure, lb/sq ft
q	dynamic pressure, lb/sq ft
q _c	impact pressure, lb/sq ft
R	slant range, yd
S	wing area, sq ft
T _a	ambient air temperature, °F abs
T _t	total temperature, °F abs
t	time, sec
W	weight, lb
Δh	altitude correction for curvature of earth and refraction of light, yd
ΔM	Mach number error
θ	elevation angle, mils
λ _H	lag constant of total-pressure system, sec
λ _p	lag constant of static-pressure system, sec
μ	coefficient of viscosity, slugs/ft-sec
ρ	density, slugs/cu ft
Subscript:	
0	sea-level conditions in standard NACA atmosphere

METHODS

The principal method used at the NACA High-Speed Flight Station for determining the Mach number of research airplanes during flight is

from the relationship of impact pressure to static pressure based on the equation for compressible flow ($M < 1.0$)

$$\frac{q_c}{p} = (1.0 + 0.2M^2)^{7/2} - 1 \quad (1)$$

At Mach numbers greater than 1.0 equation (1) is modified to include the loss in total pressure behind a normal shock wave. Equation (1) then becomes ($M > 1.0$)

$$\frac{q_c}{p} = 1.2M^2 \left(\frac{5.76M^2}{5.6M^2 - 0.8} \right)^{5/2} - 1 \quad (2)$$

Impact and static pressures are measured and recorded directly. From these measurements the ratio $\frac{q_c}{p}$ is calculated and then converted to Mach number from tables similar to those of reference 2.

The accuracy with which Mach numbers may be obtained from this relationship is dependent on the errors in the determination of q_c and p . These errors are caused by several factors: type of pressure-sensing device, recording mechanism, pressure field around the aircraft, and lag of the recording system. Thus, the overall Mach number accuracy must be evaluated with regard to these individual errors.

The errors of the sensing device and recording mechanism are dependent on the type of instruments used. Considerable developmental work has been undertaken to increase the accuracy of these instruments and, as a result, the errors normally form a small part of the overall Mach number errors.

The errors caused by the pressure field around the aircraft are the differences between the measured static pressures and the true free-stream static pressures. At transonic speeds large errors in determining Mach numbers are usually encountered because of the effects of compressibility on the static pressures in the vicinity of the static-pressure orifices. It has not been possible to find a location on an aircraft that will indicate free-stream static pressures except for a very limited speed range. Various methods have been developed for calibrating the static-pressure error caused by the pressure field around aircraft. The accuracy of these calibrations, referred to as position-error calibrations, is dependent on the errors of the instrumentation and methods used to obtain the calibration.

The accuracy of determination of Mach numbers from pressure measurements depends also on the response of the recording system to changes in pressures encountered during flight. In dives, for example, the lag of the pressure-measuring system may introduce large static-pressure and impact-pressure errors and therefore Mach number errors. These errors are dependent on the physical size of the measuring system and recording mechanism and on the operating pressures.

To illustrate the effect of the individual errors, the system in use at the High-Speed Flight Station is evaluated with regard to the desired accuracies. The desired accuracy of Mach number measurements varies somewhat, but for most of the research airplane flight-test programs an overall accuracy of 1 percent has been specified. For a random distribution of the individual errors of four or five measurements involved in the determination of a quantity, the total probable error of the quantity would be only 1 percent for individual errors of one-half of 1 percent. Therefore, it is desirable that the probable errors of the various quantities necessary to determine Mach numbers be less than one-half of 1 percent to realize an overall accuracy of 1 percent.

INSTRUMENTATION

Pitot-Static Heads

Various types and configurations of pitot-static heads may be employed to measure total and static pressures. The most widely used type is the conventional tube with openings at the forward end to measure total pressure, and openings along the side to measure static pressure. This type of pitot-static head is convenient because one instrument may be utilized to make the two measurements. A head of this type, shown in figure 1, is employed at the High-Speed Flight Station. These heads are normally mounted on a boom as far ahead of the nose of an airplane as is practical.

Total-pressure heads.- The significant errors normally encountered in the measurement of total pressure are caused by inclination of the axis of the head with the direction of flow. Most types of heads measure total pressure accurately when aligned with the airflow, but some heads exhibit large errors when appreciable angles of attack or sideslip are encountered. References 3 and 4 present calibrations for many total-pressure head configurations at various angles of attack and sideslip. An A-6 type head (fig. 1) was selected from these types because of its simplicity and its range of -10° to 25° in angle of attack and $\pm 10^{\circ}$ in sideslip, over which accurate total pressures can be measured. The normal ranges of angle of attack and sideslip for the research airplanes

are within these limits. Thus, it is believed that the errors in q_c caused by errors in the measurement of total pressure are negligible.

Static-pressure heads.- The largest error in the measurement of static pressure, excluding that caused by position error, is a result of flow angularities at the static-pressure orifices. The particular arrangement of the static-pressure orifices has a large effect on the magnitude of these errors. The arrangement of the orifices on the heads in use at the High-Speed Flight Station (fig. 1) has been determined from tests of orifice configurations (refs. 5 and 6) designed to increase the range of insensitivity of the head to angle of attack. This configuration exhibits large static-pressure errors at sideslip angles greater than about 3° , but constant sideslip angles are seldom maintained during flight and the fluctuating pressures resulting from sideslip oscillations can be easily faired.

Two sets of static-pressure orifices are used to provide pressures for separate static-pressure systems. One system is used to supply pressures for the recording instruments and the other system is used for the pilot's instruments. In comparison with pilot instruments, the recording instruments have a small time lag in responding to pressure changes. Therefore, a separate static-pressure system is provided for the recording instruments to eliminate the large time lags that would be encountered with a common static-pressure system.

Pressure Instruments

The wide range of pressures encountered at altitudes from sea level to 80,000 feet makes it extremely difficult to use one recording instrument to cover the complete altitude range with adequate accuracy at all altitudes. One solution is to employ instruments which cover only particular pressure ranges, with combinations of these instruments used to cover the entire range. This method is used for the measurement of both static and impact pressures.

The selection of the number of instruments and their ranges for a given installation depends on the altitude and Mach number range over which a specified Mach number accuracy is desired. From pressure-time-lag considerations the instrument volume should remain as small as possible, therefore the instrument accuracy must be evaluated with consideration for the errors caused by the added time lag of multiple instrument installations.

Static-pressure recorders.- Standard NACA static-pressure recorders are of the deflecting diaphragm aneroid type with ranges of 0 to 30 inches of mercury, 0 to 7 inches of mercury, and 0 to 3 inches of mercury.

These instruments maintain an accuracy of one-fourth of 1 percent of the respective capsule ranges with temperature calibrations required for the two lower range instruments.

The percent error in Mach number, calculated according to equations 8 and 9 of the appendix, caused by an error of one-fourth of 1 percent of capsule range in the measurement of static pressure, is shown in figure 2 for instrument ranges of 0 to 30 inches of mercury, 0 to 7 inches of mercury, and 0 to 3 inches of mercury at Mach numbers of 1.0, 2.0, and 3.0. Errors greater than one-half of 1 percent are indicated for the 0 to 30 inches of mercury instrument at altitudes above 40,000 feet; for the 0 to 7 inches of mercury instrument at altitudes above 65,000 feet; and for the 0 to 3 inches of mercury instrument at altitudes above 85,000 feet. The accuracy of a given installation can be easily evaluated from a figure of this type. This figure is also helpful in establishing the instrument ranges for proposed installations.

Impact-pressure recorders.- Impact pressure is recorded by a differential pressure capsule that measures the differential of the total pressure and static pressure. The maximum differential pressures encountered during research flights are usually less than 15 inches of mercury and in many cases are less than 3 inches of mercury. Standard NACA differential pressure recorders of the deflecting diaphragm type are available for these ranges, and almost any other range, with an accuracy of one-fourth of 1 percent of the instrument range. Figure 3 shows the Mach number errors, calculated according to equations 10 and 11 of the appendix, caused by an error of one-fourth of 1 percent of the instrument range in the measurement of impact pressures for instruments with ranges of 0 to 15 inches of mercury and 0 to 3 inches of mercury. Mach number errors of less than one-half of 1 percent would be encountered at altitudes below about 90,000 feet at Mach numbers greater than 1.0 with a two-capsule instrument of the above ranges.

CALIBRATIONS

Position-Error Calibrations

Position-error calibrations may be made by the methods used in reference 1, 7, or 8, or by a combination of these methods. On some airplanes, fly-bys (ref. 1) are made at various Mach numbers past a low altitude reference point at which static pressures can be measured accurately. This calibration up to the maximum level-flight speed at ground level can be extended to higher Mach numbers at higher altitudes by the radar methods of references 7 and 8.

These methods have been used with some research airplanes; however, fly-bys are not practical with the rocket-powered research aircraft.

Two methods have been developed, utilizing radiosonde measurements, that do not require a fly-by calibration. Both methods are modifications of the basic radar-phototheodolite calibration method, but one method relies on temperature measurements, the other on pressure measurements. Therefore, the methods will be referred to individually as either the temperature method or the pressure method. These methods make it possible to obtain calibration data during maneuvers and at any other time during flight.

The accuracy of position-error calibrations by these methods depends on the accuracies of the equipment and instrumentation employed. The accuracy of the pressure method depends on the accuracy of the radar-phototheodolite and radiosonde measurements. The accuracy of the temperature method is dependent not only on these measurements but also on measurements of total temperatures.

Equipment.- Radiosonde: Measurements of atmospheric temperature and pressure are obtained from measurements made by standard AN-AMT-4A radiosonde units carried aloft by balloons. These data are provided by the U. S. Air Force Air Weather Service Unit at Edwards Air Force Base, Calif. Standard GMD-1 tracking and recording equipment is employed.

The pressure measuring elements are built to specifications of an accuracy of ± 3 millibars (1 millibar = 0.03 in. Hg) to an altitude of about 45,000 feet and ± 1.5 millibars above this altitude. Each pressure element is calibrated by the manufacturer, but in some instances a period of two years may elapse from the calibration date to the flight date. Therefore, check calibrations are made by the NACA for each element although, in general, these check calibrations are necessary only to eliminate the units that infrequently fail to meet the specifications. The total probable error in pressure measurements, including errors caused by the receiving and recording systems, is estimated to be an average of approximately ± 3 millibars.

The temperature measuring element is made to specifications of an accuracy of about 1° F in measuring temperatures. The total probable error in measuring temperatures, including errors caused by transmitting, receiving, and recording systems, is estimated to be about $\pm 2^{\circ}$ F.

The maximum altitude at which radiosonde data may be obtained is limited at present by the altitude that the balloons can reach. The present balloons will usually burst at about 100,000 feet, although some ascents to 115,000 feet have been made. The pressure sensing element will indicate pressures up to an altitude of about 120,000 feet.

Radar phototheodolite: Geometric altitudes of the research airplanes are obtained from measurements made by an SCR584 radar unit modified into a radar phototheodolite. The phototheodolite unit includes

both accurate scales for measuring the elevation angle of the radar antenna and a camera mounted on the antenna to photograph the airplane and obtain corrections to the antenna angle readings. Slant range to the airplane is measured by the radar unit which tracks a radar beacon carried in the test airplane. The elevation angles and slant ranges are recorded by 35-millimeter cameras operating simultaneously at a rate of two frames per second.

The phototheodolite is estimated to have an accuracy of about ± 0.5 mil in measuring elevation angles. The radar range unit is estimated to have an accuracy of about ± 60 feet in measuring slant ranges. These errors in the measurement of elevation angle and slant range result in a maximum error of about 100 feet in determining geometric altitude over the normal range of elevation angles and slant ranges encountered during research flights. An altitude error of 100 feet results in errors of less than one-half of 1 percent of Mach number.

Total temperature probe: Total temperatures are measured by a total temperature probe of the type shown in figure 4. The probe forms one arm of a Wheatstone bridge and the unbalance of this bridge is recorded by a galvanometer. These probes have a temperature recovery factor of from 0.99 to 1.00 and, because of this high recovery factor, may be mounted at any location in the flow field outside the boundary layer. They are normally mounted on the underside of the forward fuselage to utilize the added shielding from solar radiation afforded by the fuselage. The probes and their associated recording instrumentation enable stagnation temperatures to be measured with an accuracy of about $\pm 1^\circ$ F.

Pressure method.- The pressure method outlined in this paper makes use of the radiosonde measurements to obtain a survey of the free-stream static-pressure variation with altitude (pressure survey). The radar phototheodolite is used to determine the altitude of the airplane during the flight. By comparing this altitude with the pressure survey, the true free-stream static pressure can be determined.

Early methods of obtaining pressure surveys from radiosonde data utilized the radar phototheodolite to track a radar reflector attached to the radiosonde, with the altitude of the radiosonde obtained from the radar measurements. This method resulted in pressure errors at a given altitude equal to the errors of the radiosonde in measuring pressures. Thus, rather large errors in the true pressure at a given altitude could exist and large discrepancies were found in some position-error calibrations. Present methods of obtaining pressure surveys from radiosonde data make use of measurements of the temperatures and pressures made by the radiosonde during ascent and by the hydrostatic equation

$$dp = -g_0 dh \quad (3)$$

If the density is expressed in terms of temperature, pressure, and the gas constant for dry air, equation (3) after integration may be used in the form

$$h = RT_a \log_e \frac{p_1}{p_2} \quad (4)$$

where h is the altitude increment between the pressure levels p_1 and p_2 ; R is universal gas constant; T_a is the average temperature of the altitude increment; and p_1 and p_2 are the pressures at the lower and upper boundaries of the altitude increment. Temperatures and pressures are recorded by the radiosonde at frequent intervals during the ascent and the altitudes corresponding to these observations are obtained by summing the altitude increments for each layer.

The errors of pressure surveys obtained by this integration method are primarily caused by errors in the measurement of pressure and temperature at each level. A complete analysis of the effects of these errors on the relationship between pressure and altitude calculated by use of equation (4) is presented in reference 9 and may be summarized briefly: The error in altitude caused by temperature errors is proportional to the altitude and percent temperature error; the error in altitude caused by pressure errors is proportional to the altitude, baric lapse rate (rate of change of temperature with pressure), pressure error, and the inverse of the temperature. For a standard NACA atmosphere the lapse rate is zero at altitudes from 35,332 feet to 104,987 feet and the altitude error caused by pressure errors would be zero. In actual practice, however, there are temperature gradients at almost all altitudes and the baric lapse rate attains large values at the higher altitude. Therefore, the accuracy of pressure surveys is difficult to evaluate except for given atmospheric conditions, but for any normal atmospheric condition the integration method is considerably more accurate than the balloon tracking method.

Figure 5 presents the Mach number errors of position-error calibrations based on radiosonde pressure surveys. The pressure survey errors were obtained by the methods of reference 9 for pressure errors of ± 3 millibars and temperature errors of $\pm 2^\circ$ F. The calculations were made for an average temperature gradient encountered during high altitude soundings of 0.6° per 1,000 feet. These data show that errors greater than one-half percent will be encountered at all Mach numbers at altitudes above 40,000 feet and only at Mach numbers greater than 2.0 at altitudes below 65,000 feet will errors of less than one percent be encountered. Thus it appears that errors up to 2 percent may be expected for position-error calibrations from radiosonde data.

Temperature method.- The temperature method of position-error calibration depends on measurements of ambient temperature and total temperature to determine Mach number as related by the equation

$$\frac{T_t}{T_a} = 1 + 0.2KM^2 \quad (5)$$

Radiosonde measurements are used to obtain a survey of the ambient-air temperature variation with altitude (temperature survey) and the radar phototheodolite is used to determine the test plane altitude during flight. The ambient air temperature is obtained and combined with the total temperature measurements of the total temperature probe to calculate true Mach numbers by means of equation (5).

The accuracy of position-error calibrations from this method is dependent on the accuracy of the measurements of T_t and T_a . As stated previously T_t can be measured with an accuracy of about $\pm 1^\circ$ F. At Mach numbers greater than 1.0 this measurement corresponds to errors of less than one-half of 1 percent in Mach number measurements over the normal range of atmospheric temperatures encountered.

The largest errors in position-error calibrations from temperature measurements are caused by errors in the determination of ambient air temperature. Presented in figure 6 are the Mach number errors, calculated according to equation 12 of the appendix, caused by errors of 0° to 5° in the measurement of T_a at a value of T_a of -60° F. This value was selected as representative of the average temperature at high altitudes and the Mach number errors would not be changed significantly for other temperatures normally encountered.

An evaluation of the errors in a temperature survey, obtained from radiosonde measurements similar to that previously shown for pressure surveys, results in errors of about 2.5° F abs in the measurement of T_a . Figure 6 shows that temperature errors of this magnitude would produce Mach number errors of 2 percent at Mach numbers near 1.0 and errors of less than 1 percent at Mach numbers greater than 2.0. A comparison of these data with figure 5 shows the lower errors of the temperature method at the higher Mach numbers.

Lag Calibrations

The accurate measurement of pressures becomes increasingly difficult at high altitude because of the large time lag of systems in responding to pressure changes at very low pressures. This condition can be seen from the equations (ref. 1) relating the time lag at any

pressure to the time lag at sea-level pressure. For static pressure systems

$$\lambda_p = \lambda_{p_0} \frac{p_0}{p} \frac{\mu}{\mu_0} \quad (6)$$

For total pressure systems

$$\lambda_H = \lambda_{H_0} \frac{p_0}{H} \frac{\mu}{\mu_0} \quad (7)$$

For static pressure systems the ratio $\frac{p_0}{p} \frac{\mu}{\mu_0}$ increases from a value of 4.3 at 40,000 feet to a value of 75 at 100,000 feet. Therefore, extremely low values of λ_{p_0} are necessary for time lags to be negligible at the higher altitudes. The lags of total pressure systems depend on total pressure and altitude and must be evaluated in terms of both Mach number and altitude. The value of λ_{H_0} is normally smaller than λ_{p_0} and, together with a lower ratio of $\frac{p_0}{H}$ than $\frac{p_0}{p}$, normally results in total pressure lags considerably less than those of static pressure systems.

The Mach number errors associated with time lags depend on the rate of change of pressure, but normally if the lag is less than 0.1 second, Mach number errors are small and corrections for lag are not required. In practice, ground calibrations are made by measuring the lag at various rates of change of pressure at pressures corresponding to the expected flight conditions. If the lag is shown to be excessive, efforts are made to reduce the lag by increasing tubing size, reducing tubing length, or reducing instrument volume to a value where corrections will not be required.

Figure 7 presents the time lags at various altitudes for two typical static-pressure recording installations in research airplanes. Although the instrument volumes are extremely small and the tubing length is short, it appears that lag corrections may be required during flight at altitudes above about 80,000 feet and λ_{p_0} must be known very accurately to make accurate lag corrections. For example, an error of 0.004 second in λ_{p_0} will cause an error of 0.1 second in λ_p at 80,000 feet.

EXAMPLE

The airspeed-altitude measuring and recording system of the D-558-II research airplane is typical of current installations of various research airplanes at the High-Speed Flight Station. Since the D-558-II has been flown to extreme altitudes and Mach numbers, the methods used with this airplane are illustrated. Data are presented for a flight to maximum altitude and a flight to maximum Mach number.

Airplane

The D-558-II research airplane is a single-place, 35° swept-wing airplane with a gross weight of about 16,000 pounds. It is powered by a four-cylinder rocket engine with a total thrust of 6,000 pounds at sea level. Sufficient fuel is carried for about 700 cylinder-seconds of operation. A three-view drawing of the airplane is shown in figure 8. Reference 10 presents a complete description of the physical characteristics of the airplane.

Instrumentation

The total and static pressures were measured by a pitot-static head of the type shown in figure 1. The pitot-static head was mounted with the static-pressure orifices at a location 3.93 body diameters ahead of the maximum fuselage diameter and 0.95 body diameter ahead of the nose of the airplane.

Static and differential pressures were recorded by a four-capsule airspeed-altitude recorder located in an instrument compartment immediately behind the cockpit and connected to the pitot-static head by approximately 18 feet of $3/16$ inch (outside diameter) tubing. During the flight to maximum altitude a recorder was used with static pressure capsule ranges of 0 to 30 inches of mercury and 0 to 3.0 inches of mercury and a differential pressure capsule range of 0 to 15 inches of mercury. This installation exhibited static pressure lags of 0.063 second at sea level and 1.8 seconds at 80,000 feet. At a Mach number of 1.0 the lag of the total pressure system was 0.005 second at sea level and 0.20 second at 80,000 feet. To reduce the lag for the high Mach number flight, the recording instrument was moved to a compartment ahead of the cockpit, resulting in a reduction of lag of the static pressure system to about 0.016 second at sea level and to 0.20 second at 60,000 feet. The lag of the total pressure system at 60,000 feet and a Mach number of 2.0 was about 0.014 second. For the maximum Mach number flight a recorder was used with static-pressure capsule ranges of 0 to 7 inches

of mercury and 0 to 3 inches of mercury and differential-pressure capsule ranges of 0 to 15 inches of mercury and 0 to 3.5 inches of mercury.

A standard NACA total temperature probe of the type shown in figure 4 was mounted on the nose-wheel door to measure total temperatures.

Position-Error Calibration

The position error was calibrated by both the temperature method and the pressure method at altitudes from 50,000 feet to 70,000 feet. The calibration for Mach numbers from 1.2 to 2.0 is presented in figure 9. Zero position-error correction is shown for this Mach number range and good agreement is obtained for the two calibration methods.

Maximum Altitude Flight

A U. S. Navy exploratory flight to high altitude was made with the D-558-II research airplane in August 1953, resulting in the maximum altitude obtained with this airplane. A time history of pressure altitude, Mach number, and normal-force coefficient from launch to maximum altitude is shown in figure 10.

Maximum altitude was obtained from the radar phototheodolite measurements shown in table I. The maximum altitude above the radar station was 80,949 feet, resulting in an altitude above sea level of 83,235 feet. The error of the radar phototheodolite in measuring altitudes at these elevation angles and slant ranges is estimated to be about ± 100 feet.

The value of maximum pressure altitude was difficult to evaluate because the bow shock wave passed over the static-pressure orifices as the airplane decelerated through a Mach number of 1.0 just before the peak altitude was reached. The large time lag of the system in responding to the pressure change associated with the shock wave passage resulted in large pressure errors at peak altitude. It is extremely difficult to make lag corrections for this condition unless the Mach number is stabilized or decreases below about 0.90. For this flight the Mach number began to increase after reaching a value of about 0.96 and it was not possible to correct accurately the pressure data. A fairing was then made of the pressure-altitude data by comparing it with the geometric-altitude data. This comparison indicated that maximum pressure altitude of about 81,180 feet was reached. This value is about 2,000 feet lower than the geometric altitude but differences of this amount have been noted during other flights to high altitude and indicate the variation of the pressures at these altitudes from the NACA standard atmosphere.

Maximum Mach Number Flight

An exploratory flight to high Mach number was made by the NACA in November 1953, which resulted in the maximum Mach number obtained with the D-558-II. A time history of pressure altitude, Mach number, and normal-force coefficient for this flight is shown in figure 11. A climb was made to about 72,000 feet where a shallow dive was started. Maximum Mach number was reached at 62,000 feet.

The computations for determining Mach number are shown in table II. These data show that a maximum Mach number of 2.005 was reached. This corresponds to a true airspeed of 1,327 miles per hour based on standard atmospheric temperature. The temperature indicated by radiosonde data, however, was 22° F below standard, resulting in a true airspeed of 1,291 miles per hour.

The accuracy of these measurements can be evaluated by the methods previously outlined. The errors in Mach number caused by errors in the measurement of static and impact pressures as obtained from figures 2 and 3 are

ΔM (static)	± 0.003
ΔM (impact)	± 0.003

The error of the position-error calibration is obtained from figures 5 and 6 in the altitude range at which the calibration data were obtained (50,000 ft to 70,000 ft). The error expected from the pressure method is ± 0.020 and the error from the temperature method is ± 0.014 . An inspection of the position-error calibration presented in figure 9 shows that a value of about ± 0.015 for the accuracy of the position-error calibration is reasonable. The individual errors result in a total probable error for ΔM of ± 0.02 in the measurement of maximum Mach number. The error in true airspeed corresponding to this Mach number error and an error of 2.5° F in the measurement of ambient air temperature is about ± 17 miles per hour.

CONCLUDING REMARKS

The accuracies associated with Mach number measurements based on pitot-static pressures are evaluated with respect to the individual errors of the measuring instruments, recording instruments, position-error calibrations, and time lag. The methods and instruments employed at the NACA High-Speed Flight Station at Edwards, Calif., are used to illustrate the magnitudes of the errors associated with Mach number measurements at supersonic speeds and at high altitudes. It is

indicated that the largest Mach number errors are caused by inaccuracies of position-error calibrations and that an overall accuracy of 1 percent will be difficult to attain.

Data are presented for two modified methods of the basic radar-phototheodolite method of position-error calibration. These methods are based on radiosonde measurements of pressure and temperature and are not dependent on a fly-by or low-level position-error calibration.

The practical application of these methods and instruments to the flights performed by the U. S. Navy and the NACA with the D-558-II research airplane resulted in the determination of the following values and accuracies for maximum altitude and maximum Mach number:

Maximum geometric altitude, ft	83,235 ±100
Maximum pressure altitude, ft	81,180 ±500
Maximum Mach number	2.005 ±0.02
Maximum true airspeed, mph	1,291 ±17

High-Speed Flight Station,
National Advisory Committee for Aeronautics,
Edwards, Calif., October 28, 1955.

APPENDIX

CALCULATION OF MACH NUMBER ERRORS

Error Caused by Error in Measuring Static

Pressure and Impact Pressure

After differentiation of equation (1) for $M \leq 1.0$, the following expressions for Mach number error corresponding to an error in static pressure and impact pressure are obtained (figs. 2 and 3)

$$\frac{\Delta M}{M} = \frac{1.0 - (1 + 0.2M^2)^{7/2}}{1.4M^2(1.0 + 0.2M^2)^{5/2}} \frac{\Delta p}{p} \quad (8)$$

and

$$\frac{\Delta M}{M} = \frac{(1 + 0.2M^2)^{7/2} - 1.0}{1.4M^2(1.0 + 0.2M^2)^{5/2}} \frac{\Delta q_c}{q_c} \quad (9)$$

After differentiation of equation (2) the following expressions are obtained for $M \geq 1.0$

$$\frac{\Delta M}{M} = \frac{1.0}{5.6(2M^2 - 1.0)} \left[\frac{(5.6M^2 - 0.8)^{7/2}}{96M^7} - 5.6M^2 + 0.8 \right] \frac{\Delta p}{p} \quad (10)$$

and

$$\frac{\Delta M}{M} = \frac{1.0}{5.6(2M^2 - 1.0)} \left[-\frac{(5.6M^2 - 0.8)^{7/2}}{96M^7} + 5.6M^2 + 0.8 \right] \frac{\Delta q_c}{q_c} \quad (11)$$

Error Caused by Error in Measuring Temperature

After differentiation of equation (5), the following expressions for Mach number errors corresponding to errors in ambient air temperature and total temperature are obtained (fig. 6)

$$\frac{\Delta M}{M} = - \frac{1.0 + 0.2KM^2}{0.4KM^2} \frac{\Delta T_a}{T_a} \quad (12)$$

and

$$\frac{\Delta M}{M} = \frac{1.0 + 0.2KM^2}{0.4KM^2} \frac{\Delta T_t}{T_t} \quad (13)$$

REFERENCES

1. Huston, Wilber B.: Accuracy of Airspeed Measurements and Flight Calibration Procedures. NACA Rep. 919, 1948. (Supersedes NACA TN 1605.)
2. Aiken, William S., Jr.: Standard Nomenclature for Airspeeds With Tables and Charts for Use in Calculation of Airspeed. NACA Rep. 837, 1946. (Supersedes NACA TN 1120.)
3. Gracey, William, Letko, William, and Russell, Walter R.: Wind-Tunnel Investigation of a Number of Total-Pressure Tubes at High Angles of Attack - Subsonic Speeds. NACA TN 2331, 1951. (Supersedes NACA RM L50G19.)
4. Gracey, William, Coletti, Donald E., and Russell, Walter R.: Wind-Tunnel Investigation of a Number of Total-Pressure Tubes at High Angles of Attack - Supersonic Speeds. NACA TN 2261, 1951.
5. Pearson, Albin O., and Brown, Harold A.: Calibration of a Combined Pitot-Static Tube and Vane-Type Flow Angularity Indicator at Transonic Speeds and at Large Angles of Attack or Yaw. NACA RM L52F24, 1952.
6. Gracey, William, and Scheithauer, Elwood F.: Flight Investigation at Large Angles of Attack of the Static-Pressure Errors of a Service Pitot-Static Tube Having a Modified Orifice Configuration. NACA TN 3159, 1954.
7. Zalovcik, John A.: A Radar Method of Calibrating Airspeed Installations on Airplanes in Maneuvers at High Altitudes and at Transonic and Supersonic Speeds. NACA Rep. 985, 1950. (Supersedes NACA TN 1979.)
8. Thompson, Jim Rogers, and Kurbjun, Max C.: Evaluation of the Accuracy of an Aircraft Radio Altimeter for Use in a Method of Airspeed Calibration. NACA TN 3186, 1954.
9. Anon.: Temperatures at the 10-MB (101,000-Foot) Level. Air Weather Service Technical Report 105-108, 1953.
10. Ankenbruck, Herman O., and Dahlen, Theodore E.: Some Measurements of Flying Qualities of a Douglas D-558-II Research Airplane During Flights to Supersonic Speeds. NACA RM L53A06, 1953.

TABLE I.- TIME HISTORY OF RADAR ALTITUDE

Time, sec	R, yd	θ , mils	$\sin \theta$	h' , yd (1)	Δh , yd	h_R , yd	h_R , ft	h , ft (2)
216.0	65,705	425.9	0.40605	26,680	246	26,926	80,778	83,064
217.0	66,002	424.2	.40452	26,699	248	26,947	80,841	83,127
217.5	66,146	423.6	.40398	26,722	249	26,971	80,913	83,199
218.0	66,304	422.6	.40309	26,726	250	26,976	80,928	83,214
218.5	66,452	421.6	.40220	26,727	251	26,978	80,934	83,220
219.0	66,576	420.7	.40138	26,722	253	26,975	80,925	83,211
219.5	66,728	419.7	.40048	26,723	255	26,978	80,934	83,220
220.0	66,886	418.7	.39958	26,726	257	26,983	80,949	83,235
221.0	67,188	416.4	.39751	26,708	260	26,968	80,904	83,190
220.0	67,464	413.8	.39517	26,660	262	26,922	80,766	83,052

$${}^1h' = R \sin \theta.$$

$${}^2h = h_R + 2,286 \text{ (elevation of radar above sea level).}$$

TABLE II.- MAXIMUM MACH NUMBER COMPUTATION

Time, sec	q_c , lb/sq ft	p , lb/sq ft	q_c/p	M
194.6	567.0	130.3	4.352	1.943
196.0	601.5	133.3	4.512	1.974
196.3	622.0	134.1	4.638	1.999
196.5	625.5	134.6	4.647	2.001
196.7	629.0	134.8	4.666	2.005
196.8	630.0	135.0	4.667	2.005
196.9	630.5	135.2	4.663	2.004
197.0	630.5	135.8	4.643	2.000
200.0	640.0	145.1	4.411	1.954
204.0	652.0	157.0	4.153	1.902

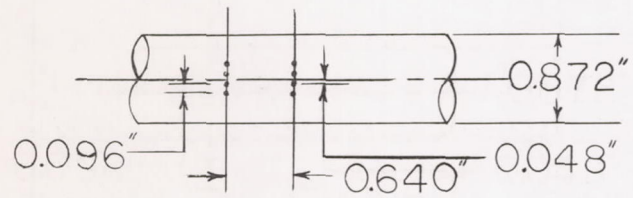
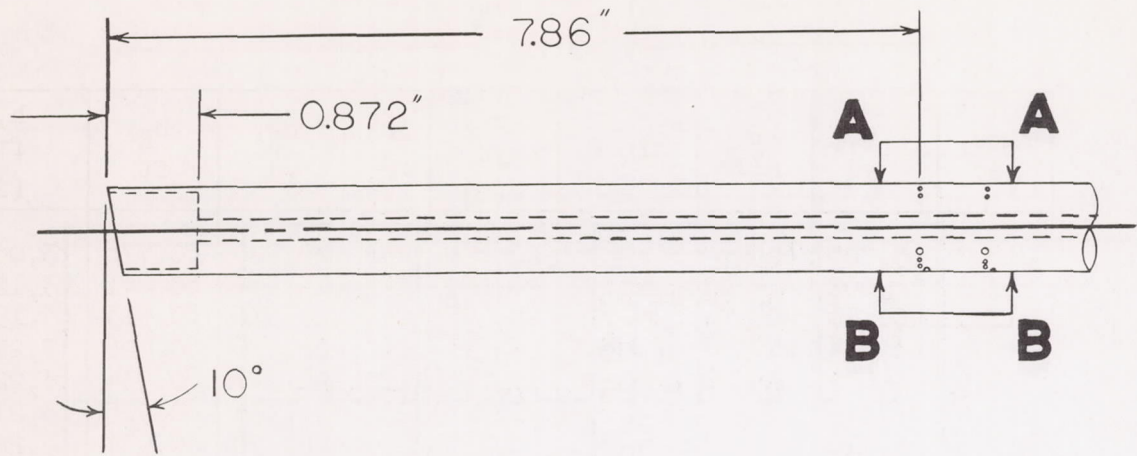

VIEW A-A

- 0.043" dia. orifice
- 0.052" dia. orifice

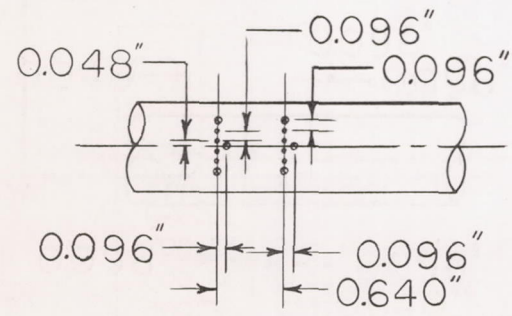

VIEW B-B

Figure 1.- Details of static and total pressure orifices.

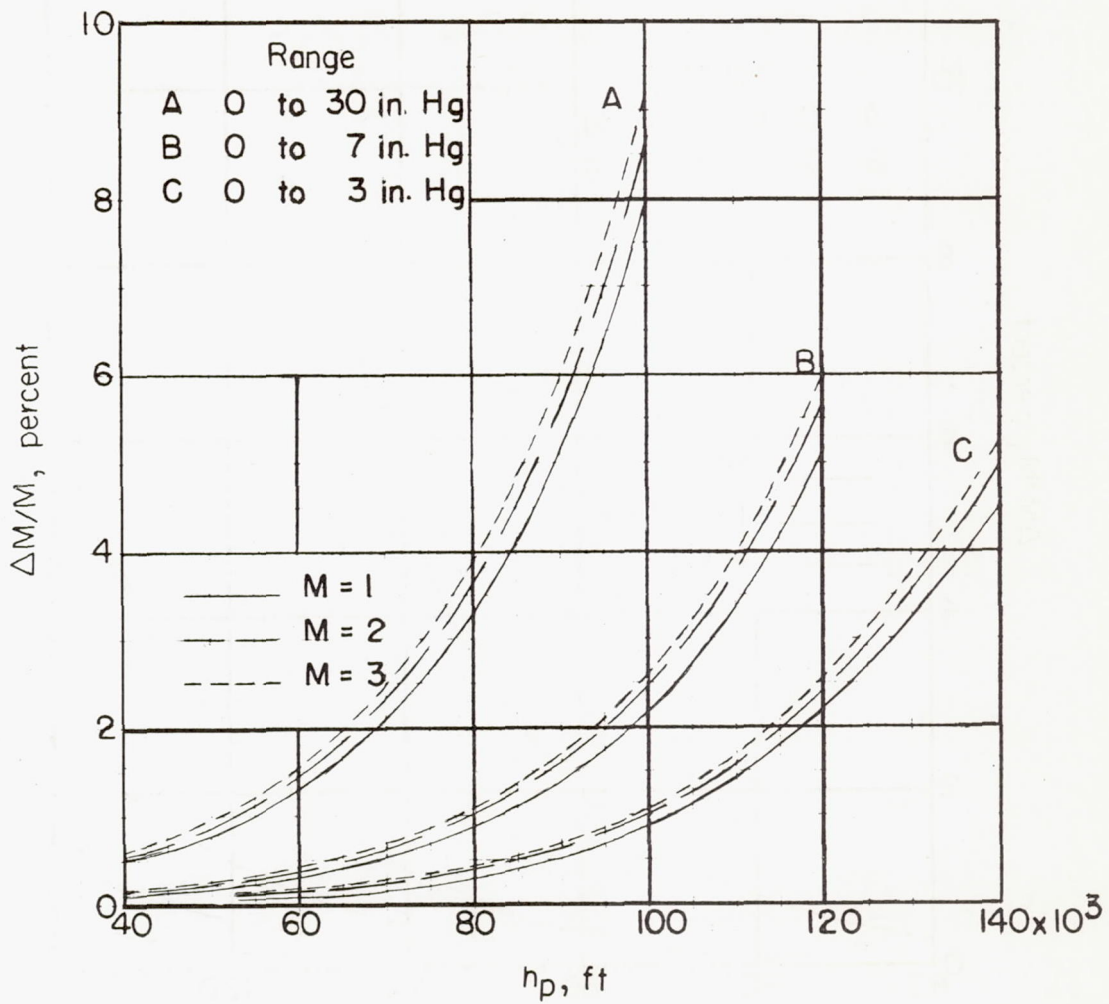

Figure 2.- Mach number errors for different ranges of static-pressure cells.

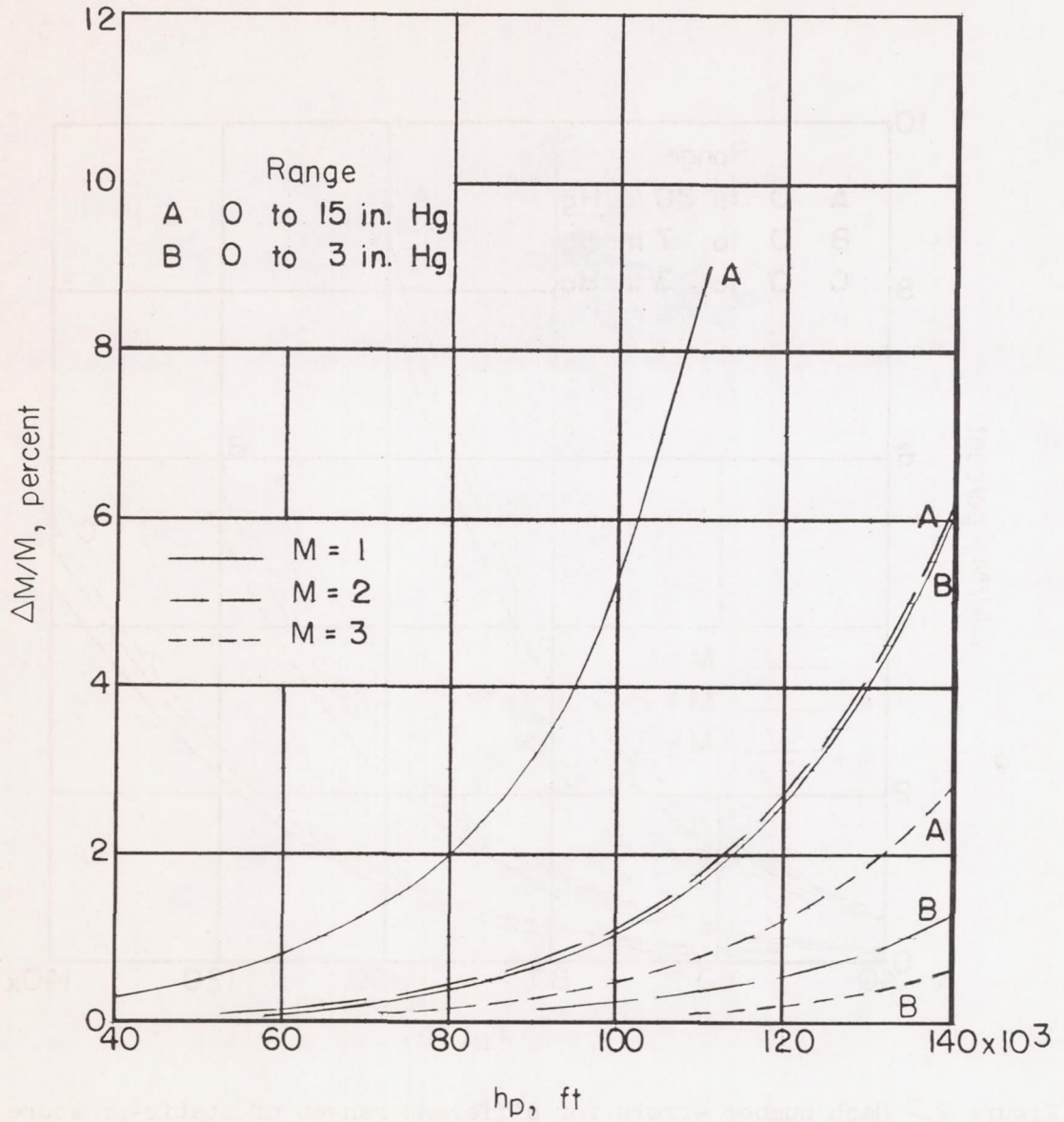

Figure 3.- Mach number errors for different ranges of impact-pressure cells.

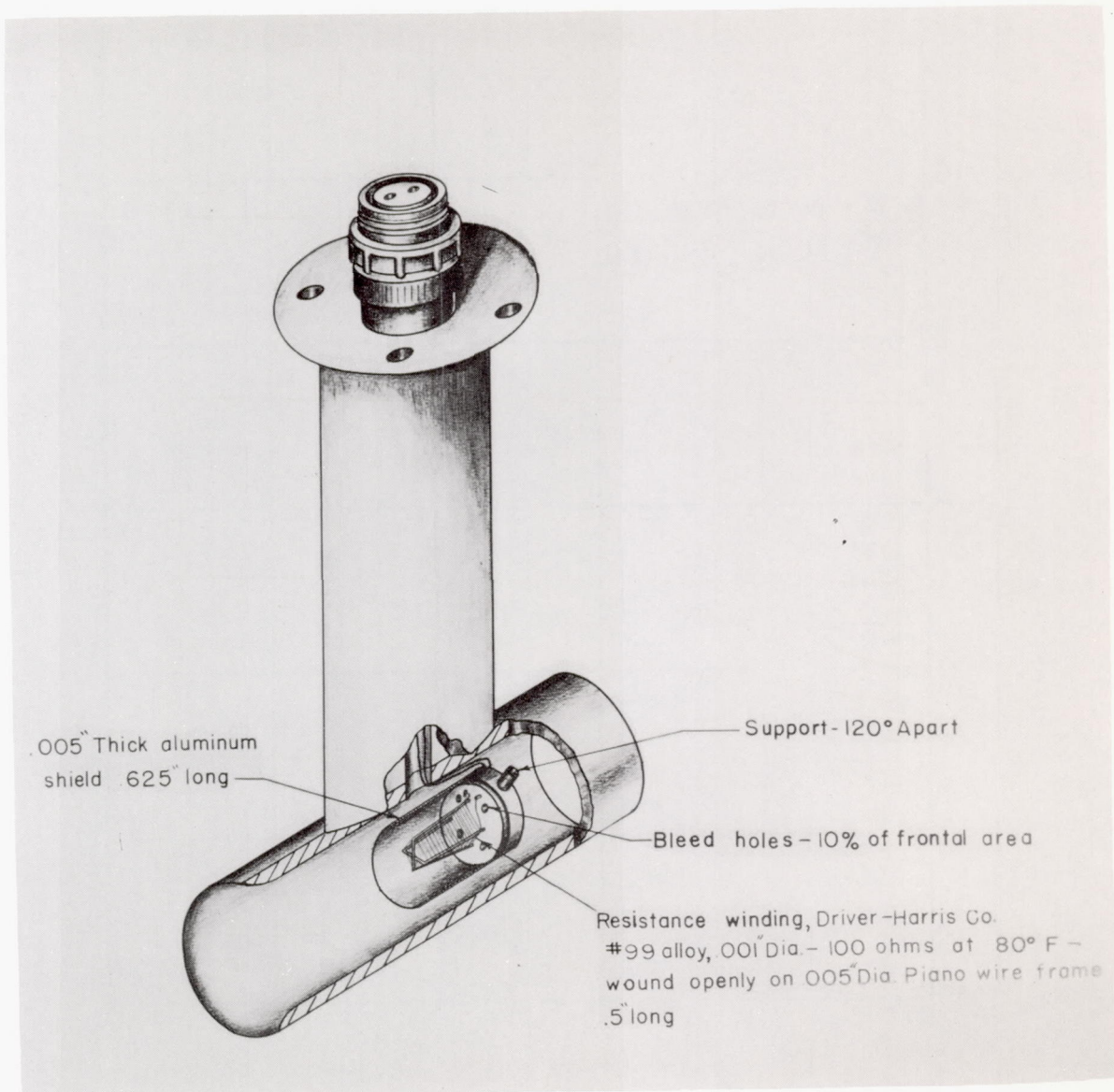

Figure 4.- Sketch of NACA total temperature probe.

L-64976

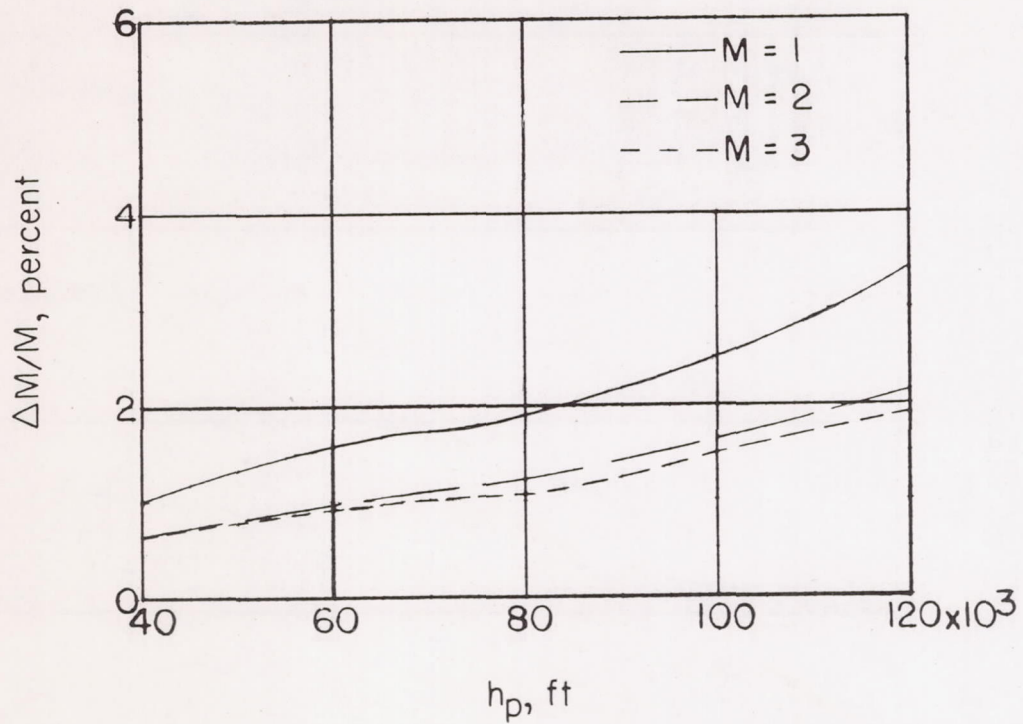

Figure 5.- Mach number errors caused by errors in radiosonde pressure surveys.

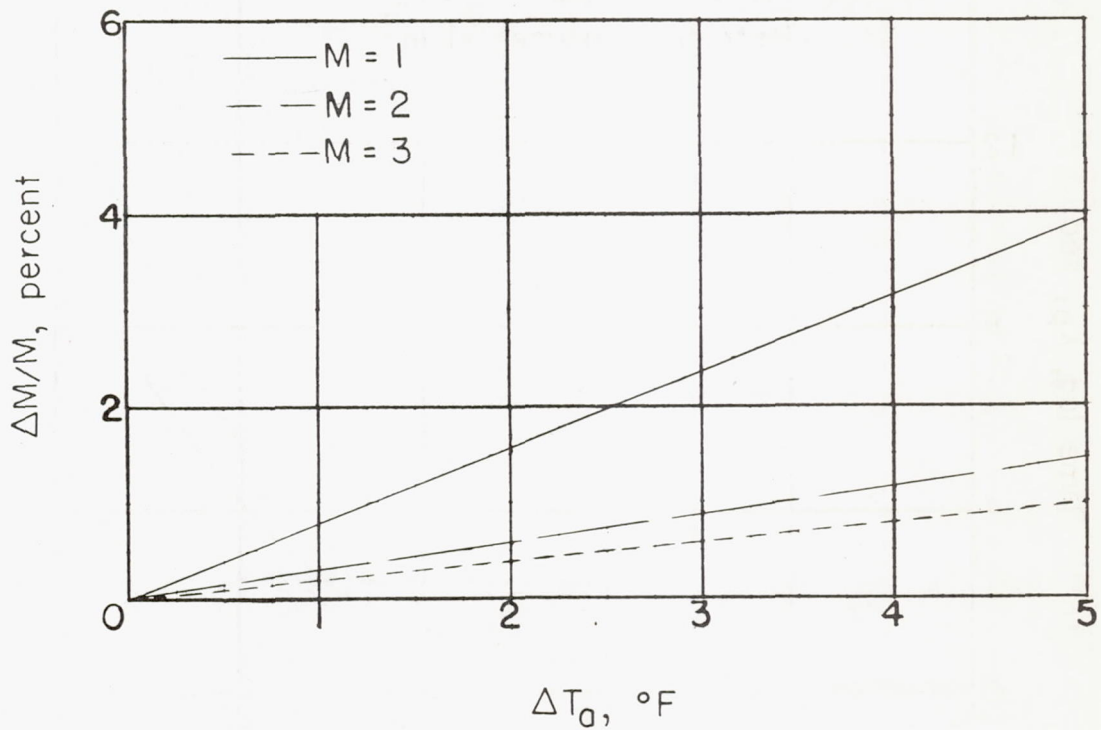

Figure 6.- Mach number errors caused by errors in the measurement of ambient air temperature for a mean temperature of -60° F.

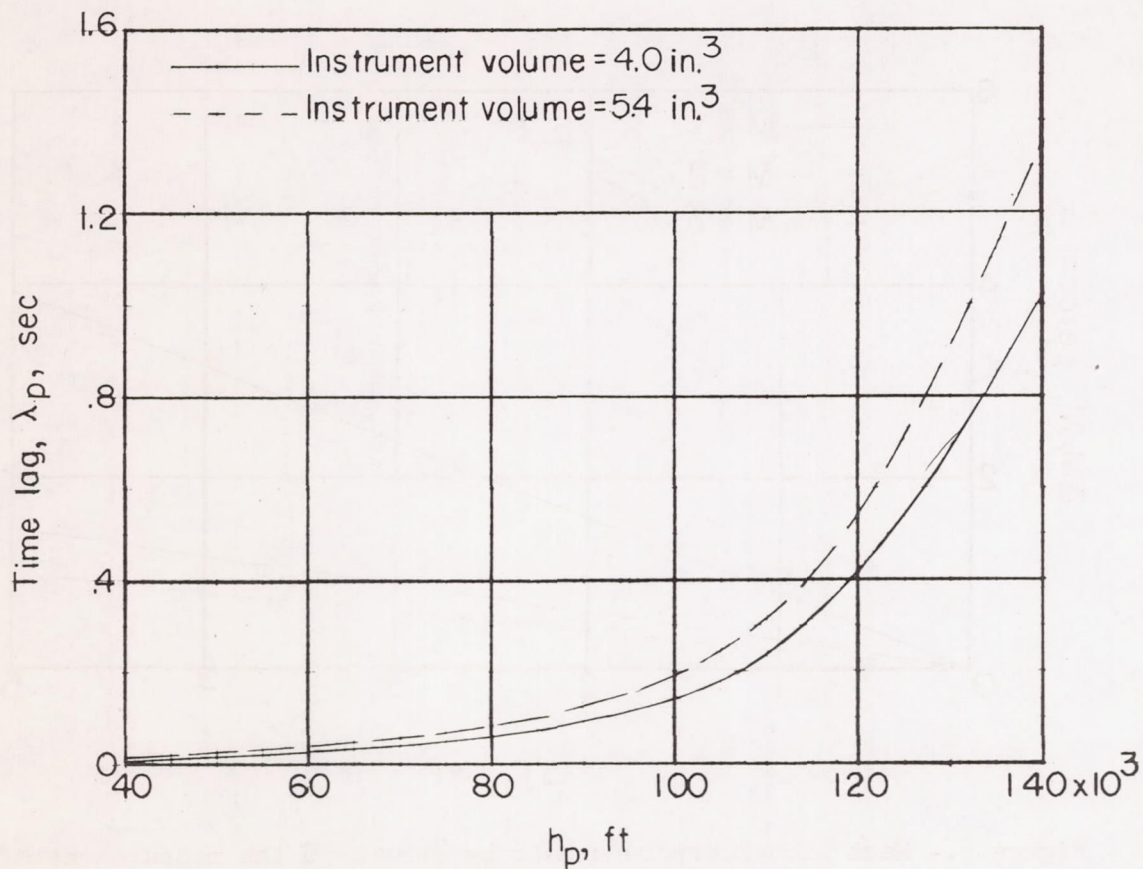

Figure 7.- Time lag in two static pressure measuring systems including 6 feet of 1/4-inch outside-diameter tubing.

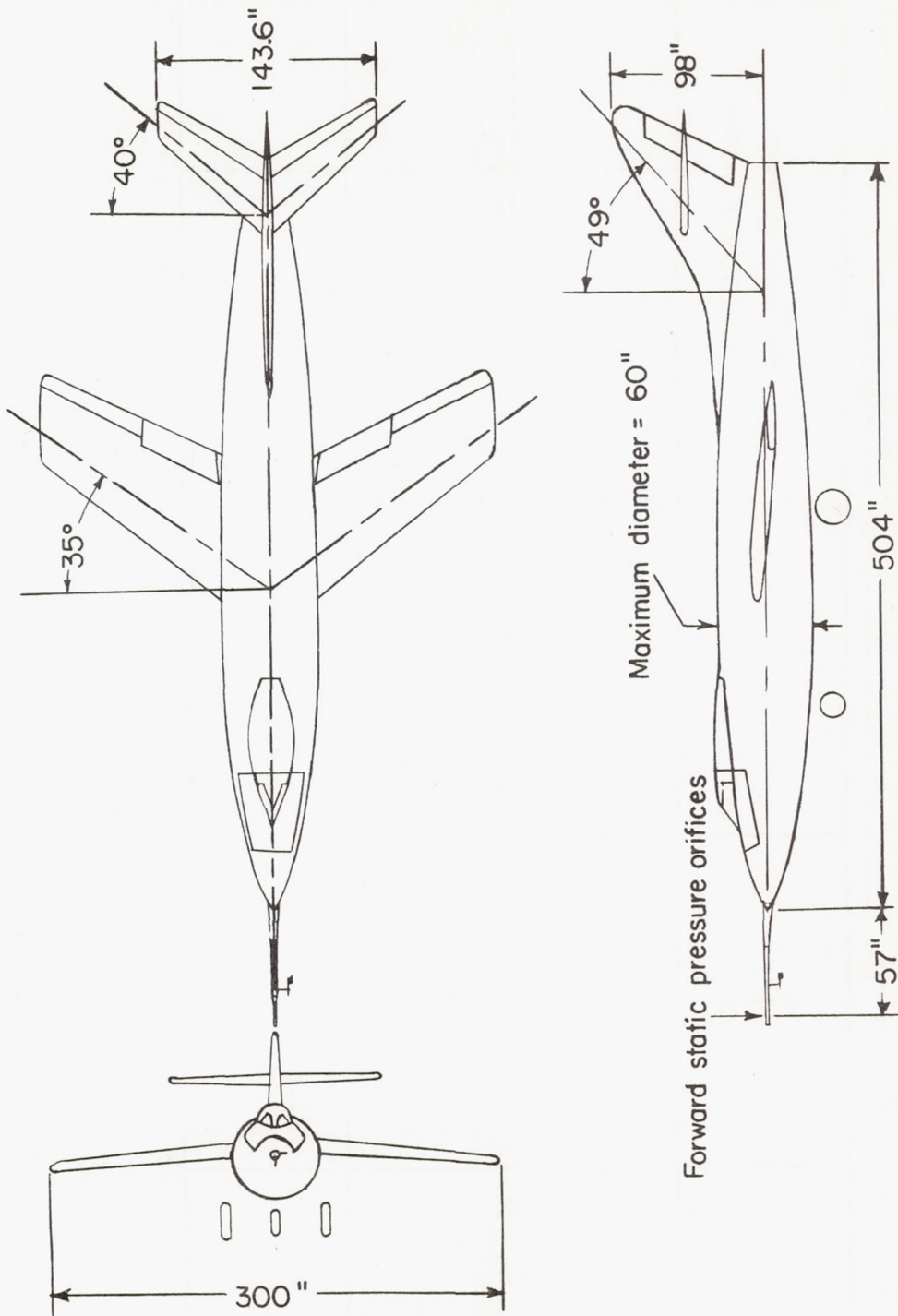

Figure 8.- A three-view drawing of the D-558-II research airplane.

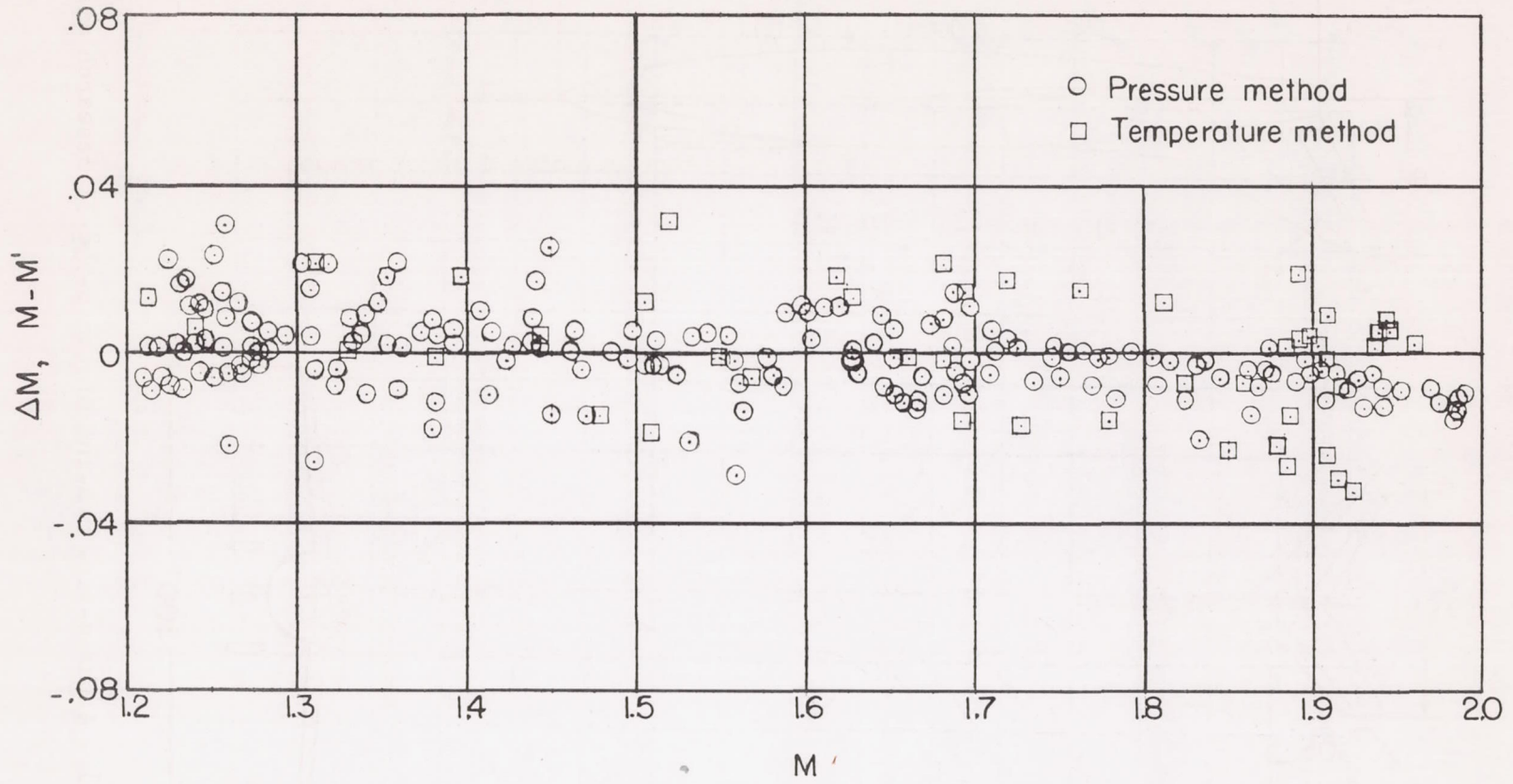

Figure 9.- Position-error calibration for the D-558-II research airplane.

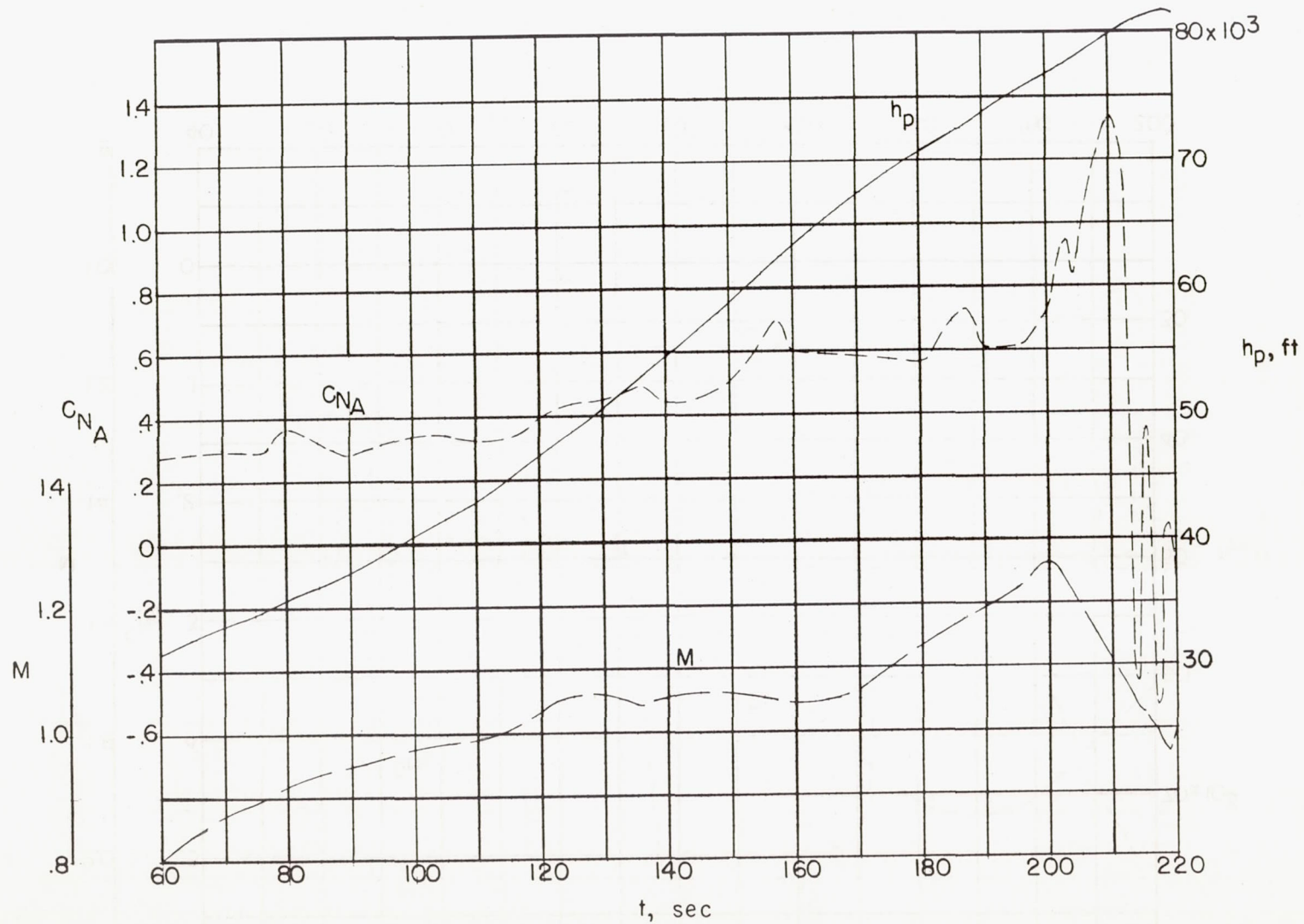

Figure 10.- Time history of flight to maximum altitude.

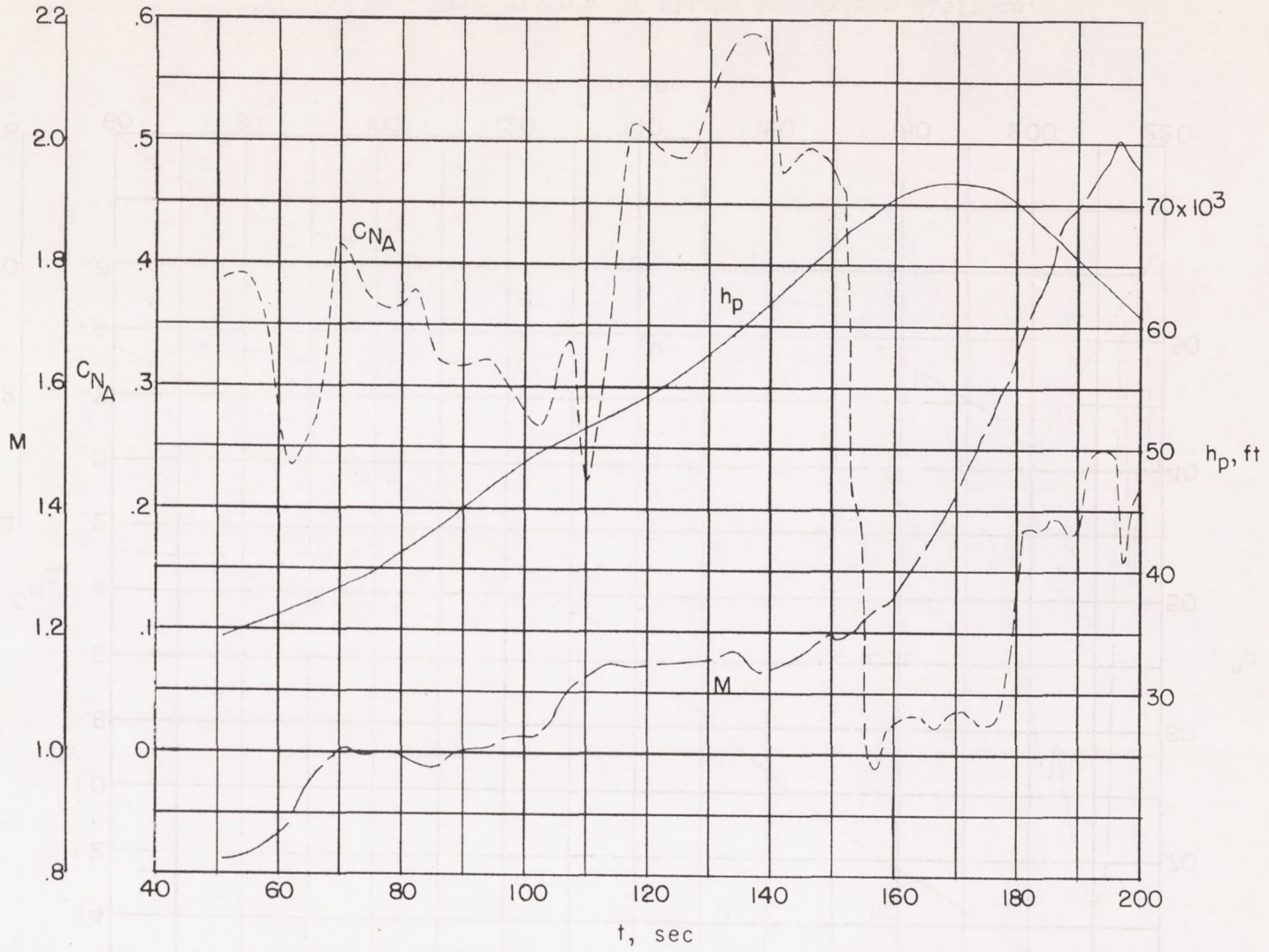

Figure 11.- Time history of flight to maximum Mach number.