

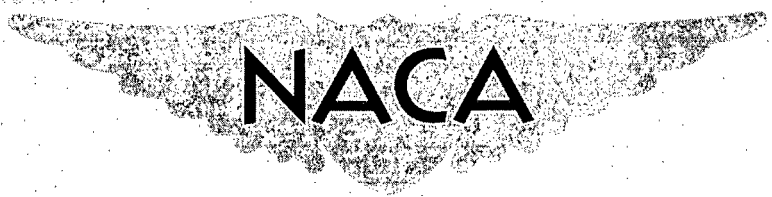
UNCLASSIFIED

CONFIDENTIAL

Copy 5
RM L57C20

NACA RM L57C20

02



RESEARCH MEMORANDUM

RESULTS OF AN INVESTIGATION AT HIGH SUBSONIC SPEEDS
TO DETERMINE LATERAL-CONTROL AND HINGE-MOMENT
CHARACTERISTICS OF A SPOILER-SLOT-DEFLECTOR
CONFIGURATION ON A 35° SWEEPBACK WING

By Alexander D. Hammond and Albert E. Brown

CLASSIFICATION CHANGED

UNCLASSIFIED

Langley Aeronautical Laboratory
Langley Field, Va.

LIBRARY COPY

To

By authority of *NASA TPA 8* *Effective* Date *7-22-59*

JUN 10 1957

NB 9-10-57

LANGLEY AERONAUTICAL LABORATORY
LIBRARY, NACA
LANGLEY FIELD, VIRGINIA

CLASSIFIED DOCUMENT

This material contains information affecting the National Defense of the United States within the meaning of the espionage laws, Title 18, U.S.C., Secs. 793 and 794, the transmission or revelation of which in any manner to an unauthorized person is prohibited by law.

NATIONAL ADVISORY COMMITTEE FOR AERONAUTICS

WASHINGTON

June 5, 1957

CONFIDENTIAL
UNCLASSIFIED



NATIONAL ADVISORY COMMITTEE FOR AERONAUTICS

RESEARCH MEMORANDUM

RESULTS OF AN INVESTIGATION AT HIGH SUBSONIC SPEEDS

TO DETERMINE LATERAL-CONTROL AND HINGE-MOMENT

CHARACTERISTICS OF A SPOILER-SLOT-DEFLECTOR

CONFIGURATION ON A 35° SWEPTBACK WING

By Alexander D. Hammond and Albert E. Brown

SUMMARY

An investigation was made in the Langley high-speed 7- by 10-foot tunnel through a Mach number range from 0.60 to 0.93 to determine the lateral-control and hinge-moment characteristics of a spoiler-slot-deflector configuration on a semispan 35° sweptback-wing model. The wing had an aspect ratio of 4, a taper ratio of 0.6, and an NACA 65A006 airfoil section. The wing was equipped with an inboard 41-percent-semispan, 15-percent-wing-chord spoiler slot deflector located between the 55- and 70-percent-chord lines. In order to provide stiffness, the spoiler and deflector had box-type sections. The tests were made at angles of attack from -4° to 26° or the angle of attack limited by tunnel choking for spoiler projections from 0 to -10 percent of the wing chord with the deflector at projections from zero to a projection equal to that of the spoiler at each spoiler projection.

The results of the investigation indicate that the spoiler-slot-deflector configuration with the ratio of deflector projection to spoiler projection increasing with increasing control projection has good rolling-moment effectiveness throughout the angle-of-attack range and throughout the high subsonic speed range. The results also indicate that a varying control-projection ratio, basically similar to that essential for good rolling-moment effectiveness, is also requisite for generally minimal total hinge-moment characteristics.

INTRODUCTION

Recent investigations of spoiler-type controls suitable for use on high-speed thin-wing configurations have shown that the spoiler slot deflector has certain advantages over the plain flap-type spoiler, such

~~CONFIDENTIAL~~

as lower hinge moments and more effectiveness at high angles of attack (for example, ref. 1).

The spoiler and deflector of a spoiler-slot-deflector configuration designed for an airplane installation would in all probability be constructed of box-type sections to withstand the loads imposed on the control in flight. The spoiler and deflector should be designed to maintain good flow properties through the slot of the control.

In order to determine the lateral-control and hinge-moment characteristics of one such box-type spoiler and deflector control configuration, an investigation was made in the Langley high-speed 7- by 10-foot tunnel of an inboard 41-percent-semispan spoiler slot deflector on a 35° sweptback-semispan-wing model.

The spoiler and deflector had a chord of 15 percent of the wing chord and were hinged along the 55-percent and 70-percent-chord line, respectively; thus tests could be made on the spoiler-slot-deflector configuration at various control projections.

COEFFICIENTS AND SYMBOLS

Most of the data are presented about the model body axes; however, the basic-wing aerodynamic characteristics (fig. 10) are presented about the wind axes. The origin of the model body axes (fig. 1) and the wind axes is on the wing-root chord at a longitudinal position corresponding to the quarter chord of the mean aerodynamic chord.

C_N	normal-force coefficient, $\frac{\text{Twice semispan normal force}}{qS}$
C_L	lift coefficient, $\frac{\text{Twice semispan lift}}{qS}$
C_A	axial-force coefficient, $\frac{\text{Twice semispan axial force}}{qS}$
C_D	drag coefficient, $\frac{\text{Twice semispan drag}}{qS}$
C_m	pitching-moment coefficient referred to $0.25\bar{c}$, $\frac{\text{Twice semispan pitching moment}}{qS\bar{c}}$

- ΔC_l rolling-moment coefficient produced by control, $\frac{\text{Rolling moment}}{qSb}$
- ΔC_n yawing-moment coefficient produced by control, $\frac{\text{Yawing moment}}{qSb}$
- C_h hinge-moment coefficient about control hinge axis,

$$\frac{\text{Hinge moment}}{2q(\text{area moment of control about its hinge line})}$$
- $C_{h,t}$ total hinge-moment coefficient, $C_{h,s} + \frac{d\delta_d}{d\delta_s} C_{h,d}$
- q free-stream dynamic pressure, lb/sq ft
- S twice wing area of semispan model, 4.00 sq ft
- c local wing chord, ft
- \bar{c} mean aerodynamic chord, $\frac{2}{S} \int_0^{b/2} c^2 dy$, ft
- b twice span of semispan model, 4.00 ft
- α angle of attack, deg
- M Mach number
- y spanwise coordinate measured from plane of symmetry, ft
- δ control projection (negative for spoiler trailing edge above and deflector leading edge below wing surface), fraction of wing chord

Subscripts:

- s spoiler
- d deflector
- corr corrected

APPARATUS AND MODEL

The semispan-sweptback-wing model was mounted in the Langley high-speed 7- by 10-foot tunnel adjacent to the ceiling of the tunnel, the ceiling thereby serving as a reflection plane. A small clearance was maintained between the model and the tunnel ceiling so that no part of the model came in contact with the tunnel structure. A small end plate was attached to the model root to minimize the effects on the flow over the model of air inflow into the tunnel test section through the clearance hole between the model and tunnel ceiling. The model was mounted on a five-component strain-gage balance which measured the forces and moments about the body axes of the semispan model. In addition, the spoiler and deflector were equipped with strain gages to measure moments about the hinge lines of each control. The forces and moments were measured simultaneously with calibrated recording potentiometers.

The geometric characteristics and dimensions of the semispan model are shown in figure 2. The wing was made of steel and had 35° sweepback of the quarter-chord line, an aspect ratio of 4, a taper ratio of 0.6, and had no twist or dihedral. The wing had NACA 65A006 airfoil sections parallel to the free stream. The wing was equipped with an inboard 41-percent-semispan, 15-percent-wing-chord spoiler slot deflector (fig. 2). The spoiler and deflector were hinged along the 55-percent- and 70-percent-chord lines, respectively. The spoiler and deflector had box-type sections and the material used in their fabrication was 1/16-inch sheet steel (fig. 2).

TESTS

All tests were made in the Langley high-speed 7- by 10-foot tunnel. Tests were made through a Mach number range from 0.60 to 0.93 for a range of spoiler projections from 0 to -10 percent of the wing chord with a range of deflector projections from zero to a projection equal to that of the spoiler at each spoiler projection. For all tests where the deflector was at zero projection, the gap around the deflector was sealed and no deflector hinge moments were measured. The tests were made through an angle-of-attack range from -4° to 26° at Mach numbers of 0.60 and 0.80 and to angles of attack at which tunnel choking occurred for Mach numbers of 0.85, 0.90, and 0.93. Reynolds number based on the wing mean aerodynamic chord varied from about 3.1×10^6 at $M = 0.60$ to about 4.0×10^6 at $M = 0.93$.

~~CONFIDENTIAL~~

CORRECTIONS

No blockage or jet-boundary corrections have been applied to the data since these corrections were found to be of very small magnitude. No reflection-plane corrections have been applied to the rolling-moment coefficients.

RESULTS AND DISCUSSION

The aerodynamic characteristics of the semispan-sweptback-wing model for various control projections of the spoiler-slot-deflector configurations are presented in tabular form. An index to the tabulated data is provided in table I. These data (tables II to VIII) are referred to the system of body axes shown in figure 1. The rolling-moment characteristics of the spoiler-slot-deflector configurations are presented in figure 3 and the hinge-moment characteristics in figures 4 to 9 for several angles of attack. For reference the variations of angle-of-attack, drag, and pitching-moment coefficients with lift coefficient for the 35° sweptback semispan wing with the spoiler slot deflector at zero deflection are presented in figure 10. In order to expedite the publication of the results of this investigation, only the more significant lateral-control and hinge-moment characteristics are covered in the discussion.

Rolling-moment characteristics.- In general, the rolling-moment characteristics of the configurations of the present investigation are similar to those obtained for the spoiler slot deflector with flat-plate controls reported in reference 2.

At a Mach number of 0.6 the curves of the variation of rolling moment with angle of attack for the various ratios of deflector projections to spoiler projection investigated (fig. 3) indicate that increasing the deflector projection at a given spoiler projection generally increases the rolling-moment effectiveness for all spoiler projections investigated. In general, increasing Mach number had little effect on this trend except that at negative and low positive angles of attack an increase in rolling effectiveness was noted for each given spoiler-slot-deflector configuration investigated. This increase in rolling effectiveness was more pronounced for the spoiler-slot-deflector configuration having low control projection ratios; this condition resulted in a loss in control effectiveness for a given spoiler projection above approximately $-0.02c$ with an increase in deflector projection above a projection of about one-quarter of the spoiler projection.

When the variation of the rolling-moment coefficient with angle of attack and Mach number for the various spoiler-slot-deflector configurations investigated is considered, the data of figure 3 indicate that a

spoiler-slot-deflector configuration having an increasing ratio of deflector projection to spoiler projection δ_d/δ_s with increasing control projection has good rolling-moment effectiveness throughout the Mach number range investigated.

Hinge-moment characteristics.- The variation of spoiler and deflector hinge-moment coefficients with deflector projection (figs. 4 to 8) indicates that, in general, for angles of attack below 12° , increasing spoiler deflection at a given deflector projection results in a positive increment in spoiler hinge-moment coefficients. Increasing the spoiler deflection also generally resulted in a positive increment in deflector hinge-moment coefficients except for the highest spoiler projection investigated. For spoiler projections less than approximately $-0.04c$ in this angle-of-attack range, increasing deflector projection at a given spoiler projection generally resulted in a negative increment in spoiler hinge-moment coefficients. For the entire angle-of-attack range and spoiler-projection range, increasing the deflector projection at a given spoiler projection generally results in a negative trend in deflector hinge-moment coefficient.

These trends of spoiler and deflector hinge-moment coefficients are similar to those found for a spoiler-slot-deflector configuration on this wing (unpublished) having a flat-plate spoiler and deflector except that the variation of deflector hinge-moment coefficient with deflector projection was considerably larger than that shown in the present investigation and the magnitude of the deflector hinge-moment coefficient for projections greater than about $-0.04c$ was about 1.5 to 2 times the magnitude found for this investigation.

Increasing angle of attack above 12° generally resulted in a decrease in the magnitude of spoiler hinge-moment coefficient at a given spoiler projection. This increase in angle of attack had relatively small effect on deflector hinge-moment coefficient at high deflector projections. However, the deflector hinge-moment coefficient for small deflector projections became substantially more positive with increasing angle of attack (figs. 4 to 8). Increasing Mach number generally increased the magnitude of spoiler and deflector hinge-moment coefficients. However, these effects were small and increasing Mach number resulted in less variation of deflector hinge-moment coefficient than of spoiler hinge-moment coefficient.

Total hinge-moment characteristics.- The hinge-moment characteristics shown in figures 4 to 8 indicate that small total control forces could be obtained throughout the angle-of-attack range and throughout the transonic speed range by using a control linkage that varies with control projection. The required control linkage for generally minimal total hinge-moment characteristics is one that provides an increasing ratio of deflector projection to spoiler projection with increasing control projection; this linkage provides a spoiler-slot-deflector configuration that is basically similar to that indicated in the present investigation by the rolling-moment characteristics to have good control effectiveness.

Figure 9 presents a summary of total hinge-moment coefficients (where the total hinge-moment coefficient $C_{h,t} = C_{h,s} + \frac{d\delta_d}{d\delta_s} C_{h,d}$) for one possible linkage of the deflector to the spoiler. The variation of the deflector projection with spoiler projection is shown in figure 9. This control projection curve was obtained from the following equations of two tangent parabolas:

$$\begin{aligned} \delta_d &= 0.09\delta_s - 13.50\delta_s^2 & |\delta_s| &\leq 0.05c \\ \delta_d &= 2.38\delta_s + 9.40\delta_s^2 + 0.05725 & |\delta_s| &\geq 0.05c \end{aligned}$$

The variation of the slope of the control projection curve $d\delta_d/d\delta_s$ with spoiler projection was obtained by differentiating the deflection curve.

CONCLUSIONS

A wind-tunnel investigation was made through a Mach number range from 0.60 to 0.93 to determine the lateral-control and hinge-moment characteristics of a spoiler-slot-deflector configuration on a semispan 35° sweptback-wing model. The wing had an aspect ratio of 4, a taper ratio of 0.6, and an NACA 65A006 airfoil section. The wing was equipped with an inboard 41-percent-semispan, 15-percent-wing-chord spoiler slot deflector located between the 55- and 70-percent-chord lines. The tests were made at angles of attack from -4° to 26° or the angle of attack limited by tunnel choking for spoiler projections from 0 to -10 percent of the wing chord with the deflector at projections from zero to a projection equal to that of the spoiler at each spoiler projection. The results of the investigation led to the following conclusions:

1. The spoiler-slot-deflector configuration with an increasing ratio of deflector projection to spoiler projection with increasing control projection had good rolling-moment effectiveness throughout the angle-of-attack range and throughout the high subsonic speed range investigated.
2. The required control linkage for generally minimal total hinge-moment characteristics is one that provides an increasing ratio of deflector projection to spoiler projection with increasing control

projection and is basically similar to the spoiler-slot-deflector linkage for good control effectiveness.

Langley Aeronautical Laboratory,
National Advisory Committee for Aeronautics,
Langley Field, Va., March 6, 1957.

REFERENCES

1. Lowry, John G.: Data on Spoiler-Type Ailerons. NACA RM L53I24a, 1953.
2. Vogler, Raymond D.: Wind-Tunnel Investigation at High Subsonic Speeds of a Spoiler-Slot-Deflector Combination on an NACA 65A006 Wing With Quarter-Chord Line Swept Back 32.6° . NACA RM L53D17, 1953.

TABLE I.- INDEX TO TABULATED DATA

[M = 0.60, 0.80, 0.85, 0.90, 0.93]

Table	Control projection	
	δ_s	$\frac{\delta_d}{\delta_s}$
II	0.000	Plain wing
III(a)	-.005	0
III(b)	-.005	.50
III(c)	-.005	1.00
IV(a)	-.010	0
IV(b)	-.010	.25
IV(c)	-.010	.50
IV(d)	-.010	1.00
V(a)	-.020	0
V(b)	-.020	.25
V(c)	-.020	.50
V(d)	-.020	1.00
VI(a)	-.050	0
VI(b)	-.050	.10
VI(c)	-.050	.20
VI(d)	-.050	.40
VI(e)	-.050	1.00
VII(a)	-.075	0
VII(b)	-.075	.07
VII(c)	-.075	.13
VII(d)	-.075	.27
VII(e)	-.075	.67
VII(f)	-.075	1.00
VIII(a)	-.100	0
VIII(b)	-.100	.05
VIII(c)	-.100	.10
VIII(d)	-.100	.20
VIII(e)	-.100	.50
VIII(f)	-.100	.75
VIII(g)	-.100	1.00

TABLE II.- AERODYNAMIC CHARACTERISTICS

Plain Wing

$\delta_{s,corr}$	$\delta_{d,corr}$	α , deg	C_N	C_A	C_m	ΔC_l	ΔC_n	$C_{h,s}$	$C_{h,d}$
M = 0.60									
-.0004	.0000	-4	-.2356	.0002	-.0044	.0000	.0000	-.0361	.0000
-.0003	.0000	-2	-.1174	.0063	-.0040	.0000	.0000	-.0284	.0000
-.0003	.0000	0	.0009	.0083	-.0021	.0000	.0000	-.0232	.0000
-.0002	.0000	2	.1192	.0065	-.0009	.0000	.0000	-.0206	.0000
-.0002	.0000	4	.2471	.0000	-.0008	.0000	.0000	-.0155	.0000
-.0001	.0000	6	.3699	-.0056	-.0008	.0000	.0000	-.0129	.0000
-.0001	.0000	8	.4980	-.0097	-.0066	.0000	.0000	-.0103	.0000
-.0001	.0000	10	.6084	-.0115	-.0077	.0000	.0000	-.0052	.0000
-.0001	.0000	12	.7050	-.0111	-.0084	.0000	.0000	-.0052	.0000
-.0003	.0000	14	.7355	-.0015	.0089	.0000	.0000	-.0309	.0000
-.0003	.0000	16	.7698	.0025	.0001	.0000	.0000	-.0284	.0000
-.0004	.0000	18	.8029	.0061	-.0061	.0000	.0000	-.0361	.0000
-.0004	.0000	20	.8369	.0086	-.0130	.0000	.0000	-.0361	.0000
-.0003	.0000	22	.8417	.0113	-.0208	.0000	.0000	-.0284	.0000
-.0003	.0000	24	.8392	.0134	-.0325	.0000	.0000	-.0232	.0000
-.0002	.0000	26	.8278	.0145	-.0454	.0000	.0000	-.0155	.0000
M = 0.80									
-.0009	.0000	-4	-.2667	.0001	-.0058	.0000	.0000	-.0556	.0000
-.0007	.0000	-2	-.1266	.0067	-.0042	.0000	.0000	-.0434	.0000
-.0006	.0000	0	.0010	.0084	-.0027	.0000	.0000	-.0347	.0000
-.0005	.0000	2	.1185	.0066	-.0045	.0000	.0000	-.0295	.0000
-.0004	.0000	4	.2560	.0006	-.0010	.0000	.0000	-.0261	.0000
-.0003	.0000	6	.4010	-.0058	.0015	.0000	.0000	-.0191	.0000
-.0001	.0000	8	.5271	-.0084	-.0077	.0000	.0000	-.0087	.0000
-.0001	.0000	10	.6215	-.0010	-.0074	.0000	.0000	-.0087	.0000
-.0003	.0000	12	.6784	.0021	-.0023	.0000	.0000	-.0191	.0000
-.0003	.0000	14	.7283	.0043	-.0019	.0000	.0000	-.0174	.0000
-.0003	.0000	16	.7774	.0074	-.0092	.0000	.0000	-.0208	.0000
-.0004	.0000	18	.8027	.0090	-.0180	.0000	.0000	-.0243	.0000
-.0003	.0000	20	.8408	.0103	-.0296	.0000	.0000	-.0208	.0000
-.0003	.0000	22	.8819	.0108	-.0413	.0000	.0000	-.0174	.0000
-.0002	.0000	24	.8863	.0112	-.0520	.0000	.0000	-.0122	.0000
-.0001	.0000	26	.9003	.0114	-.0665	.0000	.0000	-.0087	.0000
M = 0.85									
-.0009	.0000	-4	-.2753	.0003	-.0053	.0000	.0000	-.0534	.0000
-.0007	.0000	-2	-.1325	.0060	-.0044	.0000	.0000	-.0405	.0000
-.0006	.0000	0	.0010	.0082	-.0025	.0000	.0000	-.0324	.0000
-.0005	.0000	2	.1317	.0071	-.0021	.0000	.0000	-.0308	.0000
-.0005	.0000	4	.2677	.0004	-.0012	.0000	.0000	-.0259	.0000
-.0004	.0000	6	.4159	-.0072	-.0020	.0000	.0000	-.0227	.0000
-.0001	.0000	8	.5658	-.0085	-.0130	.0000	.0000	-.0081	.0000
-.0001	.0000	10	.6490	-.0032	-.0150	.0000	.0000	-.0065	.0000
-.0003	.0000	12	.6917	.0026	-.0090	.0000	.0000	-.0146	.0000
-.0001	.0000	14	.7537	.0056	-.0087	.0000	.0000	-.0081	.0000
-.0003	.0000	16	.7839	.0078	-.0168	.0000	.0000	-.0162	.0000
M = 0.90									
-.0010	.0000	-4	-.3057	.0008	.0016	.0000	.0000	-.0533	.0000
-.0008	.0000	-2	-.1533	.0065	-.0028	.0000	.0000	-.0411	.0000
-.0007	.0000	0	-.0055	.0087	-.0024	.0000	.0000	-.0366	.0000
-.0007	.0000	2	.1399	.0072	-.0045	.0000	.0000	-.0396	.0000
-.0007	.0000	4	.2845	.0017	-.0071	.0000	.0000	-.0396	.0000
-.0006	.0000	6	.4456	-.0046	-.0160	.0000	.0000	-.0320	.0000
-.0005	.0000	8	.5989	-.0054	-.0368	.0000	.0000	-.0244	.0000
-.0003	.0000	10	.6649	.0001	-.0257	.0000	.0000	-.0183	.0000
-.0002	.0000	12	.7329	.0051	-.0272	.0000	.0000	-.0091	.0000
M = 0.93									
-.0010	.0000	-4	-.3145	.0041	.0114	.0000	.0000	-.0531	.0000
-.0009	.0000	-2	-.1618	.0083	.0022	.0000	.0000	-.0443	.0000
-.0007	.0000	0	-.0080	.0100	-.0031	.0000	.0000	-.0339	.0000
-.0007	.0000	2	.1401	.0084	-.0082	.0000	.0000	-.0339	.0000
-.0006	.0000	4	.2830	.0046	-.0131	.0000	.0000	-.0325	.0000
-.0005	.0000	6	.4520	-.0004	-.0293	.0000	.0000	-.0251	.0000
-.0002	.0000	8	.6136	-.0012	-.0588	.0000	.0000	-.0089	.0000
-.0004	.0000	10	.6911	.0010	-.0434	.0000	.0000	-.0221	.0000

TABLE III.- AERODYNAMIC CHARACTERISTICS

(a) $\delta_s = -0.005$; $\frac{\delta_d}{\delta_s} = 0$

δ_s, corr	δ_d, corr	α, deg	C_N	C_A	C_m	ΔC_l	ΔC_n	$C_{h,s}$	$C_{h,d}$
M = 0.80									
-0.0050	0.0000	-4	-0.2367	-0.0004	-0.0049	-0.0014	0.0001	-0.0026	0.0000
-0.0049	0.0000	-2	-0.1140	0.0062	-0.0045	-0.0022	0.0002	0.0052	0.0000
-0.0049	0.0000	0	-0.0007	0.0071	-0.0025	-0.0021	0.0001	0.0077	0.0000
-0.0049	0.0000	2	0.1180	0.0064	-0.0018	-0.0014	0.0002	0.0103	0.0000
-0.0048	0.0000	4	0.2361	-0.0001	-0.0013	-0.0011	0.0003	0.0155	0.0000
-0.0048	0.0000	6	0.3637	-0.0062	-0.0005	-0.0014	0.0002	0.0206	0.0000
-0.0047	0.0000	8	0.4964	-0.0098	-0.0062	-0.0022	0.0003	0.0258	0.0000
-0.0047	0.0000	10	0.6170	-0.0122	-0.0073	-0.0023	0.0001	0.0309	0.0000
-0.0046	0.0000	12	0.7134	-0.0128	-0.0076	-0.0026	0.0002	0.0335	0.0000
-0.0048	0.0000	14	0.7390	-0.0028	0.0093	-0.0022	0.0002	0.0155	0.0000
-0.0049	0.0000	16	0.7825	0.0007	0.010	-0.0037	0.0001	0.0129	0.0000
-0.0049	0.0000	18	0.8116	0.0032	-0.0056	-0.0022	0.0001	0.0052	0.0000
-0.0050	0.0000	20	0.8408	0.0063	-0.0126	-0.0017	0.0001	-0.0026	0.0000
-0.0050	0.0000	22	0.8397	0.0090	-0.0199	-0.0028	0.0000	-0.0000	0.0000
-0.0050	0.0000	24	0.8383	0.0117	-0.0307	-0.0014	0.0001	0.0026	0.0000
-0.0049	0.0000	26	0.8364	0.0127	-0.0428	-0.0026	0.0001	0.0077	0.0000
M = 0.80									
-0.0049	0.0000	-4	-0.2640	0.0000	-0.0067	-0.0011	0.0001	0.0052	0.0000
-0.0048	0.0000	-2	-0.1372	0.0059	-0.0060	-0.0002	0.0001	0.0104	0.0000
-0.0047	0.0000	0	-0.0097	0.0084	-0.0039	-0.0004	0.0002	0.0156	0.0000
-0.0047	0.0000	2	0.1176	0.0069	-0.0025	-0.0012	0.0002	0.0174	0.0000
-0.0047	0.0000	4	0.2484	0.0008	-0.0019	-0.0007	0.0003	0.0191	0.0000
-0.0046	0.0000	6	0.3889	-0.0071	0.0010	-0.0015	0.0004	0.0226	0.0000
-0.0045	0.0000	8	0.5265	-0.0067	-0.0092	-0.0005	0.0005	0.0278	0.0000
-0.0046	0.0000	10	0.6228	-0.0020	-0.0076	0.0000	0.0035	0.0260	0.0000
-0.0046	0.0000	12	0.6805	0.0016	-0.0014	-0.0015	0.0002	0.0226	0.0000
-0.0046	0.0000	14	0.7371	0.0038	-0.0016	-0.0018	0.0002	0.0226	0.0000
-0.0045	0.0000	16	0.7698	0.0066	-0.0075	-0.0007	0.0002	0.0295	0.0000
-0.0049	0.0000	18	0.8078	0.0082	-0.0192	-0.0020	0.0002	0.0052	0.0000
-0.0048	0.0000	20	0.8558	0.0094	-0.0308	-0.0027	0.0003	0.0104	0.0000
-0.0048	0.0000	22	0.8709	0.0100	-0.0395	-0.0005	0.0002	0.0139	0.0000
M = 0.85									
-0.0052	0.0000	-4	-0.2819	0.0006	-0.0064	0.0000	0.0002	-0.0113	0.0000
-0.0048	0.0000	-2	-0.1426	0.0070	-0.0056	-0.0004	0.0002	0.0113	0.0000
-0.0047	0.0000	0	-0.0090	0.0092	-0.0045	-0.0002	0.0002	0.0178	0.0000
-0.0047	0.0000	2	0.1249	0.0077	-0.0032	-0.0003	0.0003	0.0194	0.0000
-0.0047	0.0000	4	0.2677	0.0013	-0.0018	0.0000	0.0003	0.0194	0.0000
-0.0046	0.0000	6	0.4097	-0.0065	-0.0023	0.0004	0.0003	0.0227	0.0000
-0.0044	0.0000	8	0.5598	-0.0089	-0.0130	0.0003	0.0017	0.0356	0.0000
-0.0044	0.0000	10	0.6582	-0.0030	-0.0139	-0.0007	0.0003	0.0356	0.0000
-0.0043	0.0000	12	0.7064	0.0031	-0.0075	-0.0022	0.0003	0.0405	0.0000
-0.0044	0.0000	14	0.7474	0.0059	-0.0057	0.0000	0.0002	0.0356	0.0000
-0.0046	0.0000	16	0.7683	0.0081	-0.0144	0.0006	0.0002	0.0227	0.0000
M = 0.90									
-0.0047	0.0000	-4	-0.3059	0.0017	-0.0000	-0.0001	0.0002	0.0137	0.0000
-0.0046	0.0000	-2	-0.1530	0.0091	-0.0026	0.0004	0.0001	0.0198	0.0000
-0.0045	0.0000	0	-0.0141	0.0106	-0.0042	0.0008	0.0002	0.0244	0.0000
-0.0046	0.0000	2	0.1254	0.0091	-0.0043	0.0009	0.0003	0.0198	0.0000
-0.0047	0.0000	4	0.2738	0.0027	-0.0048	0.0014	0.0003	0.0168	0.0000
-0.0046	0.0000	6	0.4401	-0.0039	-0.0145	0.0005	0.0001	0.0213	0.0000
-0.0045	0.0000	8	0.7618	-0.0078	-0.0431	0.0000	0.0016	0.0274	0.0000
-0.0042	0.0000	10	0.6740	0.0008	-0.0264	0.0000	-0.0026	0.0442	0.0000
M = 0.93									
-0.0047	0.0000	-4	-0.3136	0.0045	0.0121	0.0012	0.0000	0.0177	0.0000
-0.0045	0.0000	-2	-0.1693	0.0099	0.0036	0.0016	0.0001	0.0251	0.0000
-0.0045	0.0000	0	-0.0266	0.0113	-0.0016	0.0026	0.0001	0.0266	0.0000
-0.0045	0.0000	2	0.1221	0.0098	-0.0042	0.0030	0.0002	0.0236	0.0000
-0.0046	0.0000	4	0.2755	0.0050	-0.0072	0.0013	0.0000	0.0192	0.0000
-0.0044	0.0000	6	0.4444	0.0015	-0.0266	0.0014	0.0002	0.0310	0.0000
-0.0042	0.0000	8	0.6126	-0.0018	-0.0564	-0.0019	-0.0015	0.0428	0.0000

TABLE III.- AERODYNAMIC CHARACTERISTICS - Continued

(b) $\delta_s = -0.005$; $\frac{\delta_d}{\delta_s} = 0.50$

$\delta_{s,corr}$	$\delta_{d,corr}$	α , deg	C_N	C_A	C_m	ΔC_l	ΔC_n	$C_{h,s}$	$C_{h,d}$
M = 0.80									
-.0051	-.0029	-4	-.2363	.0013	-.0049	.0006	.0002	-.0129	-.0388
-.0051	-.0028	-2	-.1045	.0079	-.0044	.0006	.0002	-.0077	-.0287
-.0051	-.0026	0	.0008	.0088	-.0026	.0007	.0004	-.0052	-.0129
-.0051	-.0025	2	.1145	.0082	.0008	.0008	.0003	-.0090	.0000
-.0051	-.0024	4	.2379	.0016	.0013	.0015	.0003	-.0077	.0129
-.0050	-.0022	6	.3608	-.0045	.0008	.0008	.0003	-.0013	.0273
-.0050	-.0020	8	.4990	-.0082	-.0067	.0010	.0003	.0026	.0460
-.0049	-.0019	10	.6190	-.0100	-.0069	.0000	.0003	.0052	.0618
-.0050	-.0017	12	.7258	-.0107	-.0080	-.0005	.0003	.0013	.0819
-.0052	-.0012	14	.7415	.0000	.0063	.0012	.0005	-.0194	.1350
-.0052	-.0009	16	-.2298	.0070	.0019	.0007	.0001	-.0142	.1580
-.0053	-.0008	18	.9193	.0066	-.0052	.0016	.0000	-.0297	.1680
-.0054	-.0008	20	.3527	.0102	-.0129	.0004	.0001	-.0336	.1709
-.0053	-.0008	22	.8570	.0112	-.0209	-.0007	.0001	-.0271	.1709
-.0052	-.0008	24	.8605	.0133	-.0326	-.0011	.0001	-.0207	.1709
-.0052	-.0008	26	.8540	.0155	-.0472	.0011	.0001	-.0142	.1709
M = 0.80									
-.0056	-.0045	-4	-.2767	.0041	-.0062	.0023	.0004	-.0391	-.1316
-.0058	-.0047	-2	-.1428	.0108	-.0043	.0023	.0005	-.0478	-.1509
-.0063	-.0046	0	-.0217	.0136	-.0034	.0022	.0007	-.0791	-.1412
-.0063	-.0042	2	.0992	.0118	-.0015	.0022	.0006	-.0809	-.1122
-.0060	-.0035	4	.2238	.0054	.0001	.0032	.0005	-.0617	-.0648
-.0052	-.0022	6	.3712	-.0041	.0001	.0026	.0004	-.0139	.0203
-.0049	-.0018	8	.5327	-.0084	-.0077	.0026	.0002	.0087	.0474
-.0047	-.0013	10	.6456	-.0068	-.0130	-.0012	-.0002	.0183	.0784
-.0049	-.0011	12	.6865	.0028	-.0026	.0009	.0000	.0035	.1045
-.0050	-.0009	14	.7396	.0050	-.0042	.0005	.0001	-.0000	.1103
-.0052	-.0008	16	.7820	.0070	-.0090	.0012	.0000	-.0130	.1132
-.0053	-.0008	18	.8104	.0097	-.0192	.0008	.0000	-.0165	.1151
-.0053	-.0008	20	.8520	.0106	-.0294	.0012	.0000	-.0183	.1151
-.0053	-.0008	22	.8805	.0112	-.0390	.0012	.0000	-.0165	.1161
-.0052	-.0008	24	.8950	.0122	-.0524	.0013	.0000	-.0096	.1161
-.0051	-.0008	26	.9188	.0128	-.0669	.0013	.0000	-.0043	.1171
M = 0.85									
-.0058	-.0056	-4	-.2972	.0080	-.0040	.0013	.0005	-.0445	-.1962
-.0065	-.0060	-2	-.1608	.0182	-.0032	.0010	.0006	-.0858	-.2214
-.0069	-.0059	0	-.0303	.0180	-.0029	.0007	.0005	-.1084	-.2142
-.0069	-.0054	2	.0945	.0156	-.0013	.0012	.0004	-.1068	-.1836
-.0067	-.0048	4	.2255	.0086	.0005	.0015	.0004	-.0963	-.1431
-.0063	-.0039	6	.3769	-.0003	.0000	.0029	.0006	-.0752	-.0891
-.0047	-.0019	8	.5431	-.0061	-.0110	.0012	.0000	.0146	.0405
-.0047	-.0012	10	.6388	-.0018	-.0147	.0005	-.0015	.0178	.0846
-.0047	-.0010	12	.7058	.0052	-.0093	-.0004	.0000	.0170	.0927
-.0047	-.0009	14	.7528	.0073	-.0076	-.0005	.0001	.0154	.0990
-.0050	-.0008	16	.7893	.0088	-.0158	-.0006	.0000	.0016	.1035
-.0051	-.0008	18	.8433	.0104	-.0269	-.0006	-.0029	-.0049	.1044
M = 0.90									
-.0065	-.0065	-4	-.3081	.0140	-.0045	.0012	.0003	-.0799	-.2336
-.0068	-.0066	-2	-.1662	.0199	-.0047	.0013	.0001	-.0959	-.2437
-.0074	-.0068	0	-.0296	.0240	-.0058	.0015	.0002	-.1278	-.2522
-.0075	-.0067	2	.0991	.0202	-.0037	.0018	-.0001	-.1339	-.2463
-.0074	-.0062	4	.2390	.0129	-.0028	.0019	.0003	-.1301	-.2192
-.0072	-.0055	6	.3922	.0042	-.0068	.0022	.0003	-.1179	-.1777
-.0046	-.0015	8	.5924	-.0060	-.0336	.0025	-.0005	.0205	.0618
-.0044	-.0012	10	.6533	-.0008	-.0220	.0010	-.0002	.0297	.0770
-.0046	-.0011	12	.7215	.0051	-.0229	.0011	-.0001	.0213	.0829
-.0047	-.0010	14	.7576	.0075	-.0204	-.0014	.0001	.0167	.0863
M = 0.93									
-.0066	-.0067	-4	-.3149	.0167	-.0022	.0018	.0000	-.0818	-.2386
-.0069	-.0068	-2	-.1638	.0232	-.0060	.0021	-.0001	-.0965	-.2468
-.0076	-.0070	0	-.0294	.0262	-.0094	.0026	.0000	-.1334	-.2591
-.0078	-.0070	2	.1060	.0255	-.0090	.0025	.0002	-.1444	-.2550
-.0078	-.0067	4	.2388	.0170	-.0068	.0041	.0001	-.1452	-.2386
-.0076	-.0063	6	.4027	.0096	-.0191	.0035	.0001	-.1371	-.2181
-.0072	-.0053	8	.5745	.0039	-.0471	.0020	.0003	-.1128	-.1590
-.0046	-.0013	10	.6824	.0029	-.0412	.0003	-.0005	.0221	.0689
-.0044	-.0012	12	.7870	.0038	-.0512	-.0008	.0001	.0302	.0730

TABLE III.- AERODYNAMIC CHARACTERISTICS - Concluded

(c) $\delta_S = -0.005$; $\frac{\delta_d}{\delta_S} = 1.00$

$\delta_{S,corr}$	$\delta_{d,corr}$	α , deg	C_N	C_A	C_m	ΔC_l	ΔC_n	$C_{h,s}$	$C_{h,d}$
M = 0.30									
-.0053	-.0058	-4	-.2359	.0019	-.0049	.0017	.0002	-.0285	-.0777
-.0054	-.0057	-2	-.1224	.0081	-.0036	.0014	.0001	-.0375	-.0734
-.0055	-.0056	0	-.0037	.0106	-.0017	.0015	.0002	-.0479	-.0633
-.0055	-.0054	2	.1155	.0093	.0004	.0018	.0002	-.0479	-.0446
-.0055	-.0053	4	.2291	.0023	.0004	.0031	.0002	-.0479	-.0288
-.0055	-.0051	6	.3469	-.0044	.0004	.0021	.0001	-.0453	-.0115
-.0055	-.0049	8	.4850	-.0075	-.0067	.0019	.0001	-.0414	.0115
-.0055	-.0047	10	.6058	-.0099	-.0082	.0016	.0001	-.0427	.0302
-.0055	-.0044	12	.7077	-.0100	-.0072	.0011	.0002	-.0491	.0619
-.0057	-.0040	14	.7275	-.0020	-.0081	.0013	.0001	-.0672	.1021
-.0057	-.0036	16	.7741	.0601	-.0013	-.0011	.0004	-.0634	.1381
-.0058	-.0035	18	.8102	.0055	-.0069	.0014	-.0002	-.0685	.1525
-.0058	-.0034	20	.8594	.0080	-.0139	-.0006	-.0001	-.0685	.1626
-.0057	-.0032	22	.8587	.0113	-.0213	-.0004	-.0001	-.0621	.1654
-.0056	-.0032	24	.8565	.0134	-.0334	-.0014	.0000	-.0569	.1669
-.0055	-.0033	26	.8504	.0150	-.0464	.0011	-.0001	-.0479	.1698
M = 0.80									
-.0061	-.0065	-4	-.2746	.0048	-.0056	.0013	.0005	-.0671	-.1028
-.0063	-.0074	-2	-.1469	.0115	-.0041	.0019	.0006	-.0793	-.1590
-.0066	-.0074	0	-.0189	.0139	-.0029	.0015	.0007	-.1011	-.1609
-.0067	-.0072	2	.1028	.0122	-.0015	.0022	.0006	-.1028	-.1473
-.0065	-.0067	4	.2274	.0061	-.0008	.0028	.0006	-.0941	-.1163
-.0063	-.0062	6	.3614	-.0009	-.0026	.0026	.0009	-.0828	-.0814
-.0059	-.0052	8	.4995	-.0047	-.0104	.0041	.0007	-.0558	-.0116
-.0054	-.0042	10	.6267	-.0056	-.0121	-.0004	-.0002	-.0227	.0572
-.0053	-.0034	12	.6704	.0021	-.0031	.0008	-.0001	-.0200	.1057
-.0052	-.0030	14	.7269	.0044	-.0051	.0002	.0000	-.0174	.1367
-.0055	-.0026	16	.7796	.0066	-.0098	.0005	.0000	-.0296	.1590
-.0055	-.0025	18	.7547	.0091	-.0189	.0008	-.0001	-.0288	.1658
-.0054	-.0024	20	.8358	.0103	-.0303	.0004	-.0001	-.0253	.1755
-.0053	-.0022	22	.8581	.0109	-.0397	.0014	-.0001	-.0200	.1842
-.0052	-.0021	24	.7330	.0123	-.0555	.0015	.0000	-.0131	.1929
-.0052	-.0021	26	.8966	.0126	-.0682	.0018	-.0001	-.0105	.1948
M = 0.85									
-.0064	-.0081	-4	-.2955	.0070	-.0053	.0010	.0004	-.0788	-.1934
-.0066	-.0082	-2	-.1555	.0141	-.0042	.0004	.0005	-.0918	-.2033
-.0070	-.0082	0	-.0243	.0163	-.0039	.0003	.0003	-.1137	-.1988
-.0070	-.0079	2	.0976	.0146	-.0018	.0005	.0003	-.1153	-.1798
-.0069	-.0075	4	.2291	.0076	-.0000	.0007	.0003	-.1105	-.1545
-.0068	-.0071	6	.3622	-.0009	-.0013	.0028	.0006	-.1032	-.1292
-.0064	-.0061	8	.5245	-.0064	-.0102	.0034	.0003	-.0788	-.0678
-.0052	-.0042	10	.6383	-.0035	-.0142	.0004	-.0016	-.0106	.0506
-.0050	-.0032	12	.6843	.0036	-.0080	.0013	.0000	-.0024	.1129
-.0050	-.0027	14	.7247	.0054	-.0084	.0011	.0000	-.0000	.1446
-.0051	-.0024	16	.7890	.0081	-.0175	-.0011	.0000	-.0073	.1635
-.0054	-.0022	18	.8342	.0093	-.0284	-.0006	.0000	-.0219	.1735
-.0053	-.0022	20	.8329	.0100	-.0357	-.0017	-.0002	-.0171	.1762
M = 0.90									
-.0065	-.0087	-4	-.3178	.0104	-.0020	.0022	-.0001	-.0810	-.2167
-.0067	-.0083	-2	-.1697	.0172	-.0038	.0017	-.0002	-.1001	-.2269
-.0074	-.0090	0	-.0328	.0207	-.0049	.0014	-.0001	-.1307	-.2371
-.0074	-.0089	2	.0995	.0177	-.0039	.0018	-.0003	-.1299	-.2286
-.0074	-.0085	4	.2368	.0107	-.0032	.0016	.0000	-.1276	-.2074
-.0072	-.0079	6	.3903	.0020	-.0083	.0014	.0001	-.1200	-.1649
-.0068	-.0067	8	.5405	-.0048	-.0271	.0017	-.0004	-.0970	-.0994
-.0050	-.0039	10	.6496	-.0008	-.0242	.0003	-.0001	.0023	.0731
-.0048	-.0028	12	.7148	.0045	-.0250	.0001	.0000	.0084	.1292
M = 0.93									
-.0066	-.0089	-4	-.3159	.0144	.0011	.0022	-.0003	-.0836	-.2256
-.0069	-.0090	-2	-.1701	.0194	-.0031	.0024	-.0005	-.0992	-.2305
-.0074	-.0091	0	-.0354	.0215	-.0063	.0025	-.0005	-.1251	-.2363
-.0075	-.0084	2	.1006	.0201	-.0066	.0023	-.0002	-.1347	-.1927
-.0076	-.0088	4	.2366	.0134	-.0057	.0035	-.0002	-.1354	-.2207
-.0074	-.0085	6	.3979	.0060	-.0188	.0025	-.0003	-.1243	-.1992
-.0070	-.0075	8	.5778	.0023	-.0537	-.0004	.0001	-.1066	-.1449
-.0050	-.0036	10	.6816	.0010	-.0408	-.0011	-.0005	-.0000	.0807

TABLE IV.- AERODYNAMIC CHARACTERISTICS

(a) $\delta_s = -0.010$; $\frac{\delta_d}{\delta_s} = 0$

δ_s, corr	δ_d, corr	α, deg	C_N	C_A	C_m	ΔC_l	ΔC_n	$C_{h,s}$	$C_{h,d}$
M = 0.60									
-.0099	.0000	-4	-.2312	.0007	-.0075	-.0007	-.0001	.0129	.0000
-.0098	.0000	-2	-.1131	.0074	-.0070	-.0007	-.0001	.0206	.0000
-.0097	.0000	0	.0055	.0082	-.0047	-.0004	-.0001	.0258	.0000
-.0097	.0000	2	.1268	.0076	.0394	-.0002	.0000	.0284	.0000
-.0097	.0000	4	.2473	.0011	-.0021	.0002	.0000	.0284	.0000
-.0096	.0000	6	.3755	-.0056	-.0017	.0006	-.0001	.0335	.0000
-.0095	.0000	8	.4980	-.0091	-.0075	.0000	.0000	.0412	.0000
-.0095	.0000	10	.6132	-.0109	-.0081	-.0004	-.0002	.0464	.0000
-.0095	.0000	12	.7051	-.0115	-.0088	.0001	-.0002	.0438	.0000
-.0097	.0000	14	.7402	-.0026	.0089	-.0006	-.0003	.0258	.0000
-.0097	.0000	16	.7694	.0015	.0015	-.0005	-.0003	.0232	.0000
-.0099	.0000	18	.7935	.0041	-.0047	.0011	-.0005	.0103	.0000
-.0100	.0000	20	.8419	.0076	-.0130	-.0002	-.0003	-.0000	.0000
-.0100	.0000	22	.8407	.0102	-.0212	-.0013	-.0003	-.0000	.0000
-.0099	.0000	24	.8393	.0124	-.0320	.0002	-.0004	.0077	.0000
-.0099	.0000	26	.8373	.0134	-.0449	-.0011	-.0003	.0129	.0000
M = 0.80									
-.0097	.0000	-4	-.2669	.0015	-.0102	.0002	-.0001	.0191	.0000
-.0096	.0000	-2	-.1363	.0075	-.0083	.0013	-.0001	.0261	.0000
-.0095	.0000	0	-.0024	.0099	-.0065	.0004	.0001	.0313	.0000
-.0095	.0000	2	.1188	.0081	-.0046	.0004	.0001	.0330	.0000
-.0094	.0000	4	.2431	.0028	-.0039	.0015	.0001	.0347	.0000
-.0093	.0000	6	.3837	-.0044	-.0010	.0009	.0003	.0417	.0000
-.0091	.0000	8	.5275	-.0066	-.0106	.0007	.0002	.0521	.0000
-.0092	.0000	10	.6243	-.0019	-.0087	.0017	.0031	.0486	.0000
-.0092	.0000	12	.6788	.0021	-.0014	.0005	-.0002	.0469	.0000
-.0094	.0000	14	.7289	.0044	-.0015	.0008	-.0002	.0382	.0000
-.0096	.0000	16	.7777	.0063	-.0080	.0003	-.0002	.0261	.0000
-.0097	.0000	18	.7900	.0084	-.0177	.0015	-.0002	.0174	.0000
-.0097	.0000	20	.8407	.0096	-.0293	-.0002	-.0001	.0174	.0000
-.0097	.0000	22	.8725	.0102	-.0401	.0012	-.0002	.0208	.0000
-.0096	.0000	24	.8871	.0109	-.0511	.0010	-.0001	.0261	.0000
-.0095	.0000	26	.9042	.0107	-.0656	.0005	-.0002	.0295	.0000
M = 0.85									
-.0095	.0000	-4	-.2810	.0013	-.0091	.0014	.0000	.0259	.0000
-.0094	.0000	-2	-.1477	.0043	-.0079	.0016	.0000	.0324	.0000
-.0093	.0000	0	-.0234	.0100	-.0058	.0022	.0001	.0389	.0000
-.0093	.0000	2	.1201	.0089	-.0038	.0020	.0002	.0405	.0000
-.0093	.0000	4	.2506	.0028	-.0021	.0031	.0003	.0405	.0000
-.0092	.0000	6	.3988	-.0054	-.0020	.0030	.0002	.0453	.0000
-.0090	.0000	8	.5501	-.0054	-.0124	.0004	.0014	.0567	.0000
-.0090	.0000	10	.6352	-.0014	-.0120	.0029	.0003	.0567	.0000
-.0089	.0000	12	.6986	.0033	-.0069	.0003	.0000	.0648	.0000
-.0090	.0000	14	.7388	.0057	-.0070	.0015	-.0001	.0567	.0000
-.0093	.0000	16	.7727	.0079	-.0147	.0022	-.0001	.0373	.0000
M = 0.90									
-.0092	.0000	-4	-.3171	.0059	.0004	.0004	.0004	.0426	.0000
-.0091	.0000	-2	-.1673	.0100	-.0047	.0014	.0002	.0487	.0000
-.0090	.0000	0	-.0254	.0109	-.0047	.0020	.0003	.0517	.0000
-.0091	.0000	2	.1117	.0099	-.0031	.0029	.0005	.0502	.0000
-.0091	.0000	4	.2540	.0041	-.0017	.0038	.0004	.0502	.0000
-.0090	.0000	6	.4119	-.0021	-.0099	.0040	.0003	.0517	.0000
-.0089	.0000	8	.5799	-.0058	-.0363	.0002	-.0005	.0608	.0000
-.0089	.0000	10	.6630	-.0006	-.0292	-.0009	-.0001	.0608	.0000
-.0087	.0000	12	.7169	.0045	-.0251	.0001	.0000	.0715	.0000
M = 0.93									
-.0089	.0000	-4	-.3304	.0072	.0115	.0016	.0004	.0560	.0000
-.0089	.0000	-2	-.0429	.0102	.0060	.0008	.0002	.0575	.0000
-.0089	.0000	0	-.0403	.0123	-.0004	.0037	.0003	.0589	.0000
-.0089	.0000	2	.1053	.0105	-.0023	.0042	.0003	.0589	.0000
-.0089	.0000	4	.2510	.0052	-.0030	.0041	.0002	.0545	.0000
-.0088	.0000	6	.4141	.0017	-.0204	.0047	.0003	.0648	.0000
-.0085	.0000	8	.5768	.0005	-.0482	.0022	-.0012	.0766	.0000
-.0089	.0000	10	.6632	.0006	-.0345	.0028	-.0001	.0560	.0000

TABLE IV.- AERODYNAMIC CHARACTERISTICS - Continued

(b) $\delta_s = -0.010$; $\frac{\delta_d}{\delta_s} = 0.25$

$\delta_{s,corr}$	$\delta_{d,corr}$	α , deg	C_N	C_A	C_m	ΔC_l	ΔC_n	$C_{h,s}$	$C_{h,d}$
M = 0.80									
-.0101	-.0028	-4	-.2266	.0012	-.0058	.0005	.0003	-.0129	-.0331
-.0101	-.0027	-2	-.1125	.0074	-.0045	.0008	.0001	-.0052	-.0245
-.0100	-.0026	0	.0062	.0094	-.0026	.0010	.0003	-.0000	-.0072
-.0100	-.0025	2	.1152	.0088	.0008	.0014	.0003	.0026	.0029
-.0099	-.0024	4	.2340	.0017	.0017	.0026	.0003	.0078	.0115
-.0098	-.0022	6	.3674	-.0045	.0013	.0017	.0002	.0142	.0259
-.0098	-.0021	8	.4950	-.0081	-.0063	.0015	.0001	.0194	.0446
-.0098	-.0019	10	.6107	-.0104	-.0078	.0012	.0000	.0207	.0619
-.0099	-.0017	12	.7273	-.0106	-.0080	-.0002	.0001	.0129	.0820
-.0100	-.0013	14	.7384	-.0026	.0094	.0019	.0000	.0039	.1252
-.0100	.001	16	.2710	.0043	.0012	.0025	-.0002	-.0026	.1511
-.0102	-.0008	18	.8259	.0050	-.0056	.0015	-.0001	-.0194	.1669
-.0103	-.0007	20	.8323	.0630	-.0132	-.0019	.0005	-.0259	.1770
-.0102	-.0007	22	.8447	.0108	-.0191	.0013	-.0002	-.0207	.1770
-.0102	-.0007	24	.8671	.0133	-.0322	-.0013	.0000	-.0168	.1813
-.0101	-.0007	26	.8500	.0200	-.0469	.0006	-.0001	-.0078	.1798
M = 0.80									
-.0099	-.0029	-4	-.2610	.0019	-.0076	.0009	.0002	.0044	-.0281
-.0098	-.0028	-2	-.1331	.0078	-.0057	.0017	.0001	.0096	-.0233
-.0097	-.0026	0	-.0085	.0096	-.0036	.0014	.0002	.0157	-.0048
-.0097	-.0024	2	.1099	.0085	-.0011	.0023	.0002	.0174	.0048
-.0096	-.0023	4	.2377	.0032	.0004	.0026	.0002	.0218	.0136
-.0095	-.0020	6	.3786	-.0044	.0004	.0023	.0002	.0279	.0329
-.0095	-.0017	8	.1845	-.0076	-.0069	.0068	.0000	.0305	.0562
-.0096	-.0013	10	.6402	-.0059	-.0116	-.0008	-.0003	.0261	.0814
-.0097	-.0007	12	.6874	.0021	-.0014	.0004	-.0001	.0174	.1240
-.0099	-.0004	14	.7345	.0044	-.0021	.0011	-.0001	.0087	.1386
-.0101	-.0003	16	.7897	.0066	-.0087	.0003	.0000	-.0052	.1473
-.0101	-.0003	18	.8156	.0090	-.0184	.0012	-.0001	-.0087	.1502
-.0102	-.0002	20	.8554	.0100	-.0280	.0035	-.0001	-.0096	.1531
-.0101	-.0002	22	.8845	.0108	-.0391	-.0002	-.0001	-.0061	.1580
-.0100	-.0002	24	.9000	.0119	-.0519	.0012	-.0001	-.0000	.1580
-.0099	-.0001	26	.9135	.0126	-.0664	.0014	-.0001	.0044	.1599
M = 0.85									
-.0096	-.0016	-4	-.2729	.0016	-.0089	.0009	-.0004	.0203	.0569
-.0095	-.0016	-2	-.1393	.0073	-.0094	.0007	-.0004	.0268	.0596
-.0094	-.0015	0	-.0052	.0096	-.0056	.0000	-.0005	.0325	.0659
-.0094	-.0014	2	.1198	.0085	-.0032	.0001	-.0005	.0317	.0704
-.0094	-.0013	4	.2481	.0028	-.0005	.0004	-.0003	.0317	.0731
-.0094	-.0012	6	.3999	-.0054	-.0004	.0016	.0000	.0317	.0795
-.0094	-.0016	8	.5461	-.0088	-.0102	.0024	.0000	.0325	.0587
-.0095	-.0010	10	.6517	-.0035	-.0123	.0014	-.0016	.0284	.0930
-.0095	-.0006	12	.8572	.0024	-.0074	-.0012	-.0001	.0276	.1201
-.0097	-.0004	14	.7293	.0051	-.0056	.0034	-.0002	.0187	.1327
-.0100	-.0002	16	.7622	.0073	-.0128	.0024	-.0001	.0024	.1427
-.0101	-.0002	18	.8258	.0090	-.0248	.0016	-.0001	-.0041	.1472
M = 0.90									
-.0109	-.0059	-4	-.3245	.0090	.0015	.0055	-.0003	-.0489	-.2016
-.0110	-.0059	-2	-.1761	.0155	-.0004	.0052	-.0005	-.0551	-.2016
-.0112	-.0059	0	-.0362	.0177	-.0009	.0046	-.0004	-.0650	-.2007
-.0112	-.0056	2	.0930	.0157	-.0002	.0048	-.0006	-.0658	-.1820
-.0109	-.0047	4	.2365	.0080	.0004	.0046	-.0004	-.0497	-.1293
-.0098	-.0022	6	.4099	-.0027	-.0056	.0024	-.0006	.0107	.0204
-.0095	-.0017	8	.5813	-.0071	-.0327	-.0010	-.0009	.0268	.0493
-.0092	-.0009	10	.6573	-.0008	-.0222	.0014	-.0001	.0436	.0961
-.0095	-.0004	12	.7251	.0045	-.0245	.0008	-.0001	.0268	.1259
-.0095	-.0015	14	.7696	.0071	-.0234	-.0029	.0000	.0283	.0578
M = 0.93									
-.0108	-.0059	-4	-.3403	.0121	.0105	.0073	-.0006	-.0436	-.1965
-.0110	-.0060	-2	-.1894	.0173	.0053	.0068	-.0009	-.0495	-.1989
-.0111	-.0060	0	-.0491	.0203	.0013	.0070	-.0008	-.0591	-.1989
-.0112	-.0057	2	.0895	.0167	.0000	.0067	-.0007	-.0606	-.1858
-.0111	-.0053	4	.2384	.0104	-.0019	.0061	-.0007	-.0569	-.1578
-.0096	-.0019	6	.4134	-.0001	-.0159	.0041	-.0011	.0222	.0353
-.0091	-.0011	8	.5949	.0016	-.0553	.0002	.0002	.0466	.0781
-.0095	-.0008	10	.6816	.0014	-.0395	.0003	-.0007	.0259	.0970
-.0093	-.0004	12	.7686	.0033	-.0533	-.0086	.0000	.0369	.1217

TABLE IV.- AERODYNAMIC CHARACTERISTICS - Continued

(c) $\delta_s = -0.010$; $\frac{\delta_d}{\delta_s} = 0.50$

$\delta_{s,corr}$	$\delta_{d,corr}$	α , deg	C_N	C_A	C_m	ΔC_l	ΔC_n	$C_{h,s}$	$C_{h,d}$
M = 0.60									
-.0102	-.0056	-4	-.2514	.0024	-.0037	.0018	.0006	-.0220	-.0648
-.0102	-.0056	-2	-.1325	.0086	-.0028	.0017	.0005	-.0194	-.0648
-.0102	-.0054	0	-.0141	.0110	-.0013	.0015	.0007	-.0207	-.0446
-.0102	-.0053	2	.0951	.0099	.0016	.0019	.0006	-.0194	-.0288
-.0102	-.0051	4	.2088	.0033	.0025	.0032	.0006	-.0168	-.0130
-.0101	-.0050	6	.3370	-.0028	.0030	.0020	.0005	-.0116	.0029
-.0101	-.0047	8	.4700	-.0070	-.0054	.0020	.0004	-.0129	.0274
-.0102	-.0045	10	.6000	-.0100	-.0074	.0001	.0003	-.0168	.0504
-.0102	-.0042	12	-.3258	-.0071	-.0070	.0000	.0003	-.0194	.0849
-.0104	-.0037	14	.2055	-.0009	.0087	-.0005	.0003	-.0324	.1296
-.0104	-.0034	16	.7811	.0024	-.0004	.0000	.0002	-.0362	.1627
-.0106	-.0033	18	.8049	.0049	-.0057	.0002	.0001	-.0505	.1728
-.0106	-.0032	20	.8195	.0081	-.0135	.0005	.0002	-.0518	.1800
-.0105	-.0031	22	.8361	.0656	-.0215	-.0033	.0008	-.0479	.1871
-.0105	-.0031	24	.8419	.0134	-.0335	-.0010	.0002	-.0414	.1871
-.0104	-.0031	26	.8245	.0155	-.0478	.0002	.0002	-.0362	.1900
M = 0.80									
-.0102	-.0067	-4	-.2919	.0042	-.0039	.0019	.0005	-.0113	-.1117
-.0104	-.0067	-2	-.1637	.0101	-.0023	.0028	.0005	-.0218	-.1175
-.0105	-.0066	0	-.0358	.0129	-.0017	.0020	.0006	-.0323	-.1078
-.0104	-.0062	2	.0892	.0156	.0005	.0022	.0006	-.0262	-.0806
-.0102	-.0057	4	.2174	.0054	.0018	.0027	.0006	-.0113	-.0456
-.0100	-.0052	6	.3470	-.0033	.0034	.0033	.0005	-.0017	-.0136
-.0097	-.0044	8	.4944	-.0074	-.0346	.0030	.0002	.0175	.0388
-.0096	-.0039	10	.6307	-.0045	-.0113	-.0013	-.0001	.0236	.0777
-.0097	-.0032	12	.6708	.0036	-.0020	-.0003	.0000	.0192	.1214
-.0097	-.0027	14	.7308	.0091	-.0028	-.0011	.0001	.0175	.1544
-.0099	-.0024	16	.7770	.0111	-.0081	-.0003	.0001	.0035	.1738
-.0100	-.0023	18	.8119	.0093	-.0190	-.0013	.0001	.0017	.1835
-.0099	-.0021	20	.8504	.0102	-.0295	-.0007	.0000	.0035	.1942
-.0099	-.0020	22	.8755	.0116	-.0406	-.0007	.0000	.0087	.2000
-.0097	-.0019	24	.9062	.0140	-.0552	-.0021	.0000	.0157	.2068
-.0097	-.0019	26	.9046	.0130	-.0668	.0008	-.0001	.0192	.2078
M = 0.85									
-.0109	-.0056	-4	-.3063	.0099	-.0040	.0037	.0005	-.0504	-.1934
-.0110	-.0057	-2	-.1676	.0149	-.0031	.0014	.0005	-.0593	-.1988
-.0113	-.0056	0	-.0397	.0174	-.0028	.0014	.0005	-.0739	-.1952
-.0113	-.0052	2	.0886	.0150	-.0007	.0013	.0004	-.0723	-.1681
-.0110	-.0047	4	.2198	.0086	.0008	.0012	.0004	-.0585	-.1355
-.0108	-.0040	6	.3663	-.0009	.0014	.0036	.0006	-.0430	-.0931
-.0098	-.0020	8	.5274	-.0077	-.0069	.0026	.0000	.0130	.0289
-.0095	-.0011	10	.6382	-.0031	-.0128	.0002	-.0017	.0276	.0858
-.0094	-.0003	12	.6962	.0035	-.0080	-.0002	.0000	.0325	.1355
-.0094	.0001	14	.7583	.0059	-.0087	-.0017	.0000	.0325	.1626
-.0097	.0004	16	.8075	.0084	-.0189	-.0023	.0001	.0187	.1807
-.0099	.0004	18	.8365	.0092	-.0278	-.0020	.0000	.0081	.1852
-.0099	.0005	20	.8663	.0098	-.0379	-.0047	-.0001	.0081	.1907
M = 0.90									
-.0110	-.0060	-4	-.4706	.0122	-.0008	.0056	-.0001	-.0535	-.2099
-.0112	-.0061	-2	-.1744	.0179	-.0010	.0032	-.0002	-.0634	-.2133
-.0115	-.0061	0	-.0401	.0202	-.0028	.0036	-.0002	-.0787	-.2141
-.0115	-.0060	2	.0919	.0182	-.0016	.0036	-.0004	-.0802	-.2073
-.0114	-.0057	4	.2319	.0111	-.0004	.0029	-.0001	-.0749	-.1869
-.0112	-.0049	6	.3940	.0020	-.0065	.0023	.0000	-.0657	-.1402
-.0097	-.0018	8	.5582	.0060	-.0258	.0011	-.0009	.0153	.0391
-.0095	-.0010	10	.6617	.0005	-.0250	.0005	-.0002	.0283	.0884
-.0094	-.0001	12	.7155	.0068	-.0227	.0012	-.0002	.0328	.1427
-.0095	.0004	14	.7854	.0083	-.0280	-.0046	.0000	.0283	.1699
M = 0.93									
-.0110	-.0062	-4	-.3306	.0165	.0073	.0054	-.0001	-.0518	-.2140
-.0112	-.0063	-2	-.1851	.0216	.0069	.0050	-.0005	-.0614	-.2157
-.0115	-.0063	0	-.0390	.0229	-.0023	.0052	-.0005	-.0792	-.2181
-.0116	-.0063	2	.1002	.0206	-.0021	.0052	-.0003	-.0829	-.2157
-.0116	-.0060	4	.2411	.0135	-.0030	.0053	-.0003	-.0814	-.2008
-.0115	-.0056	6	.3993	.0067	-.0163	.0043	-.0004	-.0792	-.1761
-.0096	-.0015	8	.5826	.0009	-.0474	.0018	-.0005	.0222	.0601
-.0096	-.0009	10	.6942	-.0612	-.0450	-.0003	-.0001	.0192	.0905
-.0091	.0000	12	.8098	-.0601	-.0601	-.0106	.0005	.0459	.1440

TABLE IV.- AERODYNAMIC CHARACTERISTICS - Concluded

(d) $\delta_s = -0.010$; $\frac{\delta_d}{\delta_s} = 1.00$

δ_s, corr	δ_d, corr	α, deg	C_N	C_A	C_m	ΔC_l	ΔC_n	$C_{h,s}$	$C_{h,d}$
M = 0.60									
-.0103	-.0112	-4	-.2606	.0052	-.0033	.0025	.0006	-.0245	-.1206
-.0103	-.0112	-2	-.1417	.0113	-.0037	.0027	.0005	-.0297	-.1206
-.0105	-.0111	0	-.0238	.0138	-.0022	.0022	.0007	-.0452	-.1135
-.0105	-.0109	2	.0901	.0126	.0003	.0026	.0006	-.0452	-.0948
-.0105	-.0108	4	.2087	.0061	.0012	.0039	.0005	-.0439	-.0790
-.0105	-.0106	6	.3315	-.0006	.0012	.0028	.0004	-.0413	-.0574
-.0105	-.0103	8	.4594	-.0047	-.0067	.0033	.0004	-.0413	-.0287
-.0105	-.0100	10	.5792	-.0081	-.0077	.0020	.0002	-.0452	-.0014
-.0106	-.0096	12	.6908	-.0089	-.0076	.0010	.0002	-.0568	.0417
-.0107	.009	14	.7037	-.0012	.0090	.0004	.0000	-.0646	.1005
-.0109	-.0086	16	.7692	.0031	.0001	.0005	-.0001	-.0775	.1436
-.0110	-.0084	18	.7984	.0061	-.0060	.0013	-.0001	-.0904	.1580
-.0111	-.0083	20	.8279	.0087	-.0135	.0007	-.0001	-.0968	.1695
-.0110	-.0082	22	.8468	.0118	-.0209	-.0005	-.0001	-.0904	.1781
-.0109	-.0082	24	.8353	.0140	-.0321	-.0003	-.0001	-.0839	.1810
-.0109	-.0082	26	.8284	.0151	-.0459	.0012	-.0001	-.0775	.1810
M = 0.80									
-.0111	-.0126	-4	-.2868	.0088	-.0046	.0018	.0010	-.0660	-.1738
-.0113	-.0126	-2	-.1661	.0155	-.0033	.0030	.0010	-.0781	-.1767
-.0115	-.0127	0	-.0388	.0172	-.0018	.0024	.0011	-.0911	-.1786
-.0116	-.0126	2	.0792	.0158	-.0007	.0034	.0010	-.0955	-.1719
-.0114	-.0123	4	.2068	.0097	.0005	.0043	.0010	-.0877	-.1574
-.0114	-.0120	6	.3470	.0024	-.0015	.0039	.0012	-.0868	-.1371
-.0114	-.0115	8	.4803	-.0035	-.0071	.0043	.0006	-.0877	-.1033
-.0111	-.0102	10	.6045	-.0036	-.0112	.0013	-.0002	-.0660	-.0126
-.0105	-.0084	12	.6642	.0032	-.0020	.0008	.0000	-.0304	.1091
-.0106	-.0078	14	.7239	.0047	-.0033	.0003	.0000	-.0347	.1458
-.0108	-.0075	16	.7789	.0073	-.0104	-.0005	.0001	-.0477	.1661
-.0108	-.0074	18	.7945	.0094	-.0194	.0005	.0000	-.0503	.1719
-.0108	-.0073	20	.8390	.0106	-.0314	.0004	.0000	-.0512	.1796
-.0107	-.0072	22	.8641	.0112	-.0401	.0004	-.0001	-.0434	.1902
-.0106	-.0070	24	.7138	.0124	-.0532	.0031	-.0001	-.0347	.1999
-.0104	-.0069	26	.8998	.0122	-.0676	.0018	-.0001	-.0260	.2095
M = 0.85									
-.0113	-.0133	-4	-.3103	.0108	-.0049	.0017	.0008	-.0737	-.2082
-.0115	-.0134	-2	-.1705	.0179	-.0038	.0014	.0008	-.0851	-.2145
-.0117	-.0133	0	-.0397	.0190	-.0029	.0012	.0006	-.0997	-.2046
-.0118	-.0130	2	.0825	.0173	-.0008	.0021	.0006	-.1013	-.1911
-.0117	-.0128	4	.2106	.0107	.0010	.0026	.0006	-.0948	-.1749
-.0116	-.0126	6	.3534	.0018	.0016	.0050	.0009	-.0932	-.1605
-.0116	-.0122	8	.5226	-.0040	-.0094	.0025	.0003	-.0932	-.1352
-.0115	-.0110	10	.6244	-.0014	-.0120	.0011	-.0015	-.0851	-.0658
-.0102	-.0081	12	.6764	.0040	-.0066	.0016	.0000	-.0130	.1190
-.0103	-.0075	14	.7508	.0059	-.0087	-.0005	.0000	-.0162	.1550
-.0106	-.0074	16	.7865	.0088	-.0169	-.0018	.0000	-.0324	.1641
-.0107	-.0072	18	.8223	.0093	-.0275	-.0009	.0000	-.0397	.1767
M = 0.90									
-.0114	-.0138	-4	-.3256	.0161	-.0019	.0029	.0004	-.0732	-.2230
-.0116	-.0139	-2	-.1749	.0206	-.0045	.0023	.0001	-.0861	-.2306
-.0119	-.0139	0	-.0438	.0226	-.0047	.0028	.0001	-.1029	-.2315
-.0120	-.0139	2	.0855	.0200	-.0019	.0035	-.0001	-.1067	-.2289
-.0119	-.0136	4	.2337	.0136	-.0018	.0021	.0003	-.1029	-.2137
-.0119	-.0133	6	.3869	.0049	-.0070	.0022	.0003	-.1029	-.1925
-.0118	-.0126	8	.5569	-.0010	-.0276	.0012	-.0002	-.0968	-.1552
-.0120	-.0121	10	.6859	.0056	-.0345	-.0030	.0004	-.1098	-.1213
-.0099	-.0088	12	.6458	.0002	-.0221	.0013	-.0001	-.0038	.0738
-.0101	-.0078	14	.7331	.0054	-.0270	-.0013	-.0001	-.0038	.1289
-.0103	-.0074	16	.7721	.0077	-.0271	-.0039	.0000	-.0175	.1543
M = 0.93									
-.0114	-.0140	-4	-.3261	.0176	.0013	.0035	.0000	-.0739	-.2285
-.0116	-.0141	-2	-.1835	.0237	-.0030	.0037	-.0001	-.0842	-.2326
-.0120	-.0141	0	-.0310	.0098	-.0069	.0042	-.0003	-.1035	-.2367
-.0120	-.0141	2	.0931	.0230	-.0052	.0041	.0000	-.1064	-.2367
-.0121	-.0139	4	.2396	.0158	-.0065	.0041	.0000	-.1079	-.2244
-.0121	-.0137	6	.3989	.0085	-.0168	.0046	-.0002	-.1116	-.2096
-.0120	-.0132	8	.5727	.0060	-.0504	.0017	.0006	-.1042	-.1833
-.0121	-.0122	10	.6593	.0046	-.0321	.0014	-.0004	-.1108	-.1258

TABLE V.- AERODYNAMIC CHARACTERISTICS

(a) $\delta_s = -0.020$; $\frac{\delta_d}{\delta_s} = 0$

δ_s, corr	δ_d, corr	$\alpha,$ deg	C_N	C_A	C_m	ΔC_l	ΔC_n	$C_{h,s}$	$C_{h,d}$
M = 0.80									
-.0192	.0000	-4	-.2357	.0038	-.0137	.0004	.0003	.0696	.0000
-.0192	.0000	-2	-.1179	.0099	-.0132	.0001	.0004	.0747	.0000
-.0191	.0000	0	.0006	.0130	-.0100	.0003	.0004	.0773	.0000
-.0192	.0000	2	.1143	.0129	-.0071	.0010	.0005	.0747	.0000
-.0192	.0000	4	.2277	.0043	-.0048	.0020	.0005	.0747	.0000
-.0191	.0000	6	.3554	-.0023	-.0027	.0017	.0004	.0799	.0000
-.0190	.0000	8	.4975	-.0065	-.0102	.0001	.0004	.0902	.0000
-.0190	.0000	10	.6124	-.0089	-.0117	-.0006	.0002	.0902	.0000
-.0191	.0000	12	.7044	-.0100	-.0097	.0000	.0001	.0799	.0000
-.0192	.0000	14	.7392	-.0016	.0080	-.0010	-.0001	.0696	.0000
-.0195	.0000	16	.7682	.0024	.0014	-.0015	.0003	.0489	.0000
-.0197	.0000	18	.8167	.0049	-.0061	-.0015	-.0001	.0258	.0000
-.0198	.0000	20	.8403	.0080	-.0147	-.0014	.0000	.0155	.0000
-.0199	.0000	22	.8395	.0102	-.0216	-.0020	-.0002	.0129	.0000
-.0198	.0000	24	.8384	.0123	-.0329	-.0003	-.0001	.0180	.0000
-.0197	.0000	26	.8313	.0139	-.0462	-.0014	-.0001	.0258	.0000
M = 0.80									
-.0188	.0000	-4	-.2863	.0037	-.0114	.0017	.0002	.0746	.0000
-.0187	.0000	-2	-.1591	.0101	-.0089	.0031	.0002	.0781	.0000
-.0187	.0000	0	-.0316	.0128	-.0066	.0029	.0006	.0798	.0000
-.0187	.0000	2	.0894	.0122	-.0035	.0029	.0006	.0816	.0000
-.0186	.0000	4	.1290	.0073	-.0005	.0034	.0007	.0833	.0000
-.0186	.0000	6	.3508	-.0018	.0010	.0035	.0008	.0850	.0000
-.0185	.0000	8	.5037	-.0037	-.0110	.0021	.0006	.0920	.0000
-.0185	.0000	10	.6196	.0010	-.0099	.0011	.0035	.0920	.0000
-.0186	.0000	12	.6776	.0032	-.0008	-.0002	.0000	.0850	.0000
-.0189	.0000	14	.7338	.0050	-.0007	-.0010	.0000	.0642	.0000
-.0193	.0000	16	.7696	.0074	-.0083	-.0001	-.0001	.0416	.0000
-.0195	.0000	18	.7914	.0091	-.0191	.0000	.0000	.0330	.0000
-.0195	.0000	20	.8389	.0102	-.0308	-.0011	.0000	.0295	.0000
-.0195	.0000	22	.8711	.0109	-.0408	.0009	-.0016	.0330	.0000
-.0194	.0000	24	.8848	.0111	-.0525	-.0006	.0000	.0382	.0000
-.0195	.0000	26	.8992	.0111	-.0670	-.0001	-.0001	.0330	.0000
M = 0.85									
-.0186	.0000	-4	-.3175	.0042	-.0092	.0039	.0004	.0793	.0000
-.0186	.0000	-2	-.1688	.0112	-.0062	.0032	.0005	.0825	.0000
-.0185	.0000	0	-.0444	.0137	-.0046	.0042	.0006	.0858	.0000
-.0184	.0000	2	.0800	.0127	-.0020	.0045	.0008	.0890	.0000
-.0184	.0000	4	.2180	.0068	.0144	.0058	.0009	.0890	.0000
-.0184	.0000	6	.3566	-.0018	.0036	.0071	.0008	.0890	.0000
-.0184	.0000	8	.5138	-.0063	-.0067	.0039	.0017	.0922	.0000
-.0183	.0000	10	.6357	-.0021	-.0147	.0004	.0001	.0971	.0000
-.0183	.0000	12	.6909	.0043	-.0069	-.0003	.0002	.0955	.0000
-.0187	.0000	14	.7373	.0063	-.0057	.0005	.0001	.0744	.0000
-.0191	.0000	16	.7672	.0082	-.0152	.0003	.0000	.0534	.0000
M = 0.90									
-.0184	.0000	-4	-.3476	.0058	.0030	.0042	.0005	.0852	.0000
-.0183	.0000	-2	-.1945	.0117	.0010	.0051	.0011	.0898	.0000
-.0182	.0000	0	-.0553	.0147	.0003	.0061	.0007	.0974	.0000
-.0181	.0000	2	.0816	.0135	.0019	.0068	.0010	.1004	.0000
-.0181	.0000	4	.2237	.0075	.0030	.0073	.0009	.1004	.0000
-.0182	.0000	6	.3793	-.0004	-.0005	.0078	.0007	.0989	.0000
-.0182	.0000	8	.5615	-.0032	-.0275	.0027	.0000	.0974	.0000
-.0180	.0000	10	.6586	.0014	-.0229	.0000	.0001	.1081	.0000
-.0182	.0000	12	.7335	.0054	-.0109	.0000	.0001	.0989	.0000
M = 0.93									
-.0180	.0000	-4	-.3754	.0109	.0251	.0072	.0007	.1017	.0000
-.0181	.0000	-2	-.2281	.0151	.0159	.0081	.0006	.0988	.0000
-.0179	.0000	0	-.0807	.0169	.0082	.0078	.0007	.1076	.0000
-.0178	.0000	2	.0679	.0154	.0056	.0084	.0009	.1165	.0000
-.0178	.0000	4	.2163	.0097	.0044	.0079	.0007	.1121	.0000
-.0179	.0000	6	.3770	.0026	-.0067	.0085	.0004	.1091	.0000
-.0177	.0000	8	.5641	.0012	-.0403	.0036	-.0012	.1180	.0000
-.0179	.0000	10	.6632	.0036	-.0345	.0021	.0002	.1106	.0000

TABLE V.- AERODYNAMIC CHARACTERISTICS - Continued

(b) $\delta_s = -0.020$; $\frac{\delta_d}{\delta_s} = 0.25$

$\delta_{s,corr}$	$\delta_{d,corr}$	α , deg	C_N	C_A	C_m	ΔC_l	ΔC_n	$C_{h,s}$	$C_{h,d}$
M = 0.80									
-.0198	-.0052	-4	-.2746	.0037	-.0036	.0045	.0005	.0220	-.0216
-.0197	-.0051	-2	-.1103	.0091	-.0037	.0034	.0005	.0245	-.0115
-.0196	-.0048	0	-.0372	.0133	-.0009	.0049	.0008	.0323	.0172
-.0196	-.0047	2	.0766	.0127	.0020	.0049	.0008	.0362	.0302
-.0196	-.0047	4	.1904	.0062	.0038	.0065	.0008	.0375	.0345
-.0196	-.0045	6	.3235	-.0005	.0038	.0053	.0006	.0375	.0460
-.0196	-.0043	8	.4750	-.0053	-.0072	.0030	.0005	.0362	.0690
-.0197	-.0041	10	.5996	-.0082	-.0099	.0012	.0002	.0284	.0891
-.0199	-.0040	12	.6966	-.0094	-.0089	.0013	.0002	.0129	.1049
-.0200	-.0035	14	.7510	-.0022	.0093	-.0009	.0003	-.0026	.1480
-.0202	-.0033	16	.7856	.0025	.0005	.0009	-.0001	-.0220	.1710
-.0205	-.0032	18	.7952	.0051	-.0060	.0031	-.0002	-.0413	.1797
-.0205	-.0031	20	.8335	.0081	-.0135	.0005	-.0001	-.0491	.1911
-.0205	-.0030	22	.8477	.0107	-.0209	-.0002	.0000	-.0478	.1983
-.0205	-.0030	24	.8457	.0129	-.0330	-.0008	-.0001	-.0426	.1983
-.0204	-.0030	26	.8486	.0149	-.0481	.0001	.0000	-.0375	.1983
M = 0.80									
-.0194	-.0057	-4	-.3151	.0047	-.0023	.0055	.0004	.0365	-.0444
-.0193	-.0055	-2	-.1875	.0114	.0001	.0066	.0005	.0417	-.0328
-.0192	-.0050	0	-.0606	.0142	.0010	.0054	.0007	.0512	.0029
-.0191	-.0047	2	.0643	.0131	.0038	.0062	.0008	.0547	.0203
-.0191	-.0046	4	.1886	.0074	.0053	.0071	.0009	.0547	.0261
-.0191	-.0044	6	.3252	.0008	.0035	.0065	.0011	.0538	.0415
-.0191	-.0040	8	.4882	-.0036	-.0078	.0053	.0008	.0538	.0647
-.0193	-.0037	10	.6074	-.0040	-.0144	.0005	-.0001	.0417	.0850
-.0194	-.0031	12	.6610	.0029	-.0017	.0009	.0000	.0356	.1275
-.0197	-.0027	14	.7244	.0040	-.0004	.0003	.0000	.0200	.1574
-.0199	-.0024	16	.7571	.0074	-.0075	.0022	.0001	.0043	.1748
-.0201	-.0023	18	.7981	.0093	-.0206	.0004	.0000	-.0035	.1825
-.0201	-.0022	20	.8428	.0102	-.0302	.0003	.0000	-.0052	.1912
-.0200	-.0021	22	.8688	.0109	-.0387	.0015	-.0001	-.0017	.1961
-.0199	-.0020	24	.8857	.0119	-.0532	.0004	-.0001	.0069	.2009
-.0198	-.0020	26	.9168	.0125	-.0685	.0010	-.0001	.0104	.2028
M = 0.85									
-.0193	-.0068	-4	-.3499	.0062	.0017	.0087	.0000	.0421	-.1145
-.0192	-.0066	-2	-.2108	.0133	.0025	.0074	.0001	.0470	-.1010
-.0189	-.0057	0	-.0737	.0154	.0028	.0071	.0001	.0624	-.0415
-.0188	-.0050	2	.0598	.0142	.0026	.0061	.0002	.0673	.0027
-.0189	-.0048	4	.1878	.0078	.0060	.0063	.0004	.0640	.0135
-.0188	-.0045	6	.3393	-.0004	.0071	.0072	.0008	.0664	.0297
-.0188	-.0042	8	.5056	-.0065	-.0028	.0052	.0001	.0656	.0523
-.0189	-.0038	10	.6282	-.0024	-.0112	.0050	-.0015	.0600	.0766
-.0192	-.0029	12	.6774	.0027	-.0057	.0028	-.0001	.0438	.1298
-.0195	-.0024	14	.7358	.0054	-.0062	.0009	-.0001	.0308	.1605
-.0197	-.0022	16	.7842	.0084	-.0158	-.0006	.0000	.0186	.1740
-.0199	-.0021	18	.8169	.0097	-.0283	.0006	.0000	.0057	.1794
M = 0.90									
-.0192	-.0079	-4	-.3835	.0125	.0156	.0130	-.0002	.0442	-.1704
-.0191	-.0077	-2	-.2343	.0175	.0086	.0111	-.0005	.0488	-.1603
-.0188	-.0073	0	-.0840	.0190	.0045	.0091	-.0005	.0633	-.1340
-.0186	-.0065	2	.0508	.0172	.0067	.0092	-.0005	.0747	-.0907
-.0186	-.0053	4	.1960	.0098	.0071	.0079	-.0002	.0747	-.0204
-.0186	-.0046	6	.3580	.0007	.0041	.0072	.0000	.0739	.0246
-.0186	-.0041	8	.5438	-.0043	-.0211	.0034	-.0007	.0739	.0517
-.0186	-.0037	10	.6429	.0002	-.0203	.0014	-.0001	.0739	.0789
-.0188	-.0026	12	.7286	.0054	-.0232	.0005	-.0001	.0640	.1425
-.0194	-.0022	14	.7862	.0080	-.0297	-.0052	.0000	.0297	.1679
M = 0.93									
-.0189	-.0079	-4	-.3923	.0171	.0286	.0148	-.0003	.0591	-.1685
-.0188	-.0078	-2	-.2452	.0213	.0207	.0136	-.0007	.0650	-.1619
-.0186	-.0075	0	-.0997	.0220	.0117	.0132	-.0007	.0739	-.1455
-.0184	-.0070	2	.0494	.0195	.0092	.0115	-.0005	.0835	-.1167
-.0184	-.0063	4	.2036	.0125	.0060	.0101	-.0004	.0835	-.0756
-.0184	-.0047	6	.3673	.0039	-.0043	.0086	-.0006	.0835	.0189
-.0183	-.0039	8	.5499	.0008	-.0367	.0054	-.0001	.0872	.0617
-.0185	-.0035	10	.6653	.0043	-.0408	.0023	-.0004	.0798	.0888

TABLE V.- AERODYNAMIC CHARACTERISTICS - Continued

(c) $\delta_s = -0.020$; $\frac{\delta_d}{\delta_s} = 0.50$

δ_s, corr	δ_d, corr	α, deg	C_N	C_A	C_m	ΔC_l	ΔC_n	$C_{h,s}$	$C_{h,d}$
M = 0.60									
-.0197	-.0105	-4	-.2745	.0053	-.0032	.0045	.0005	.0310	-.0488
-.0196	-.0104	-2	-.1547	-.0159	-.0019	.0056	.0001	.0362	-.0373
-.0194	-.0100	0	-.0420	.0145	-.0005	.0053	.0007	.0504	-.0029
-.0194	-.0112	2	.0813	.0138	.0015	.0044	.0007	.0555	-.1235
-.0193	-.0097	4	.1971	.0076	.0333	.0062	.0008	.0607	.0330
-.0193	-.0096	6	.3184	.0006	.0038	.0057	.0006	.0607	.0417
-.0193	-.0094	8	.4550	-.0030	-.0059	.0043	.0005	.0620	.0646
-.0194	-.0091	10	.5843	-.0066	-.0095	.0021	.0004	.0568	.0919
-.0195	-.0088	12	.7006	-.0078	-.0097	.0005	.0003	.0426	.1192
-.0198	-.0083	14	.7214	.0007	.0063	.0020	.0003	.0219	.1738
-.0199	-.0079	16	.7793	.0035	.0001	.0002	.0000	.0065	.2068
-.0202	-.0078	18	.8031	.0061	-.0086	.0008	-.0001	-.0181	.2169
-.0203	-.0077	20	.8369	.0091	-.0148	-.0010	-.0001	-.0258	.2284
-.0203	-.0077	22	.8417	.0113	-.0221	-.0004	-.0001	-.0258	.2298
-.0202	-.0077	24	.8399	.0134	-.0342	-.0007	.0000	-.0207	.2312
-.0201	-.0076	26	.8378	.0161	-.0481	.0003	-.0001	-.0103	.2355
M = 0.80									
-.0194	-.0115	-4	-.3210	.0074	-.0012	.0066	.0005	.0338	-.1023
-.0194	-.0114	-2	-.1940	.0136	-.0011	.0071	.0007	.0391	-.0937
-.0192	-.0109	0	-.0634	.0164	.0003	.0063	.0008	.0495	-.0628
-.0190	-.0105	2	.0578	.0153	.0028	.0069	.0009	.0582	-.0348
-.0190	-.0103	4	.1817	.0096	.0038	.0073	.0009	.0625	-.0174
-.0190	-.0099	6	.3189	.0027	.0038	.0075	.0012	.0634	.0087
-.0190	-.0093	8	.4693	-.0013	-.0066	.0080	.0010	.0625	.0483
-.0191	-.0086	10	.5981	-.0025	-.0127	.0020	-.0002	.0538	.0946
-.0193	-.0079	12	.6647	.0043	-.0014	.0015	.0001	.0434	.1439
-.0197	-.0075	14	.7179	.0055	-.0016	.0013	.0000	.0191	.1680
-.0201	-.0072	16	.7667	.0078	-.0089	.0016	.0000	-.0061	.1873
-.0201	-.0071	18	.7982	.0097	-.0206	.0009	.0000	-.0069	.1970
-.0201	-.0069	20	.8460	.0110	-.0323	.0005	-.0001	-.0069	.2085
-.0200	-.0068	22	.8774	.0112	-.0424	-.0001	-.0001	-.0026	.2172
-.0199	-.0066	24	.8855	.0126	-.0540	.0007	-.0001	.0061	.2259
-.0198	-.0066	26	.8998	.0125	-.0670	.0018	-.0001	.0095	.2298
M = 0.85									
-.0195	-.0126	-4	-.3447	.0105	-.0007	.0071	.0004	.0292	-.1614
-.0194	-.0125	-2	-.2174	.0173	.0002	.0074	.0005	.0340	-.1587
-.0193	-.0123	0	-.0840	.0187	.0002	.0065	.0004	.0413	-.1424
-.0192	-.0118	2	.0473	.0176	.0020	.0067	.0005	.0470	-.1109
-.0190	-.0112	4	.1841	.0112	.0032	.0059	.0006	.0551	-.0739
-.0189	-.0105	6	.3238	.0021	.0041	.0084	.0008	.0616	-.0297
-.0188	-.0096	8	.4723	-.0043	-.0028	.0083	.0003	.0705	.0261
-.0188	-.0086	10	.6088	-.0013	-.0133	.0061	-.0017	.0705	.0883
-.0190	-.0077	12	.6617	.0058	-.0055	.0035	.0001	.0543	.1415
-.0194	-.0073	14	.7295	.0071	-.0084	.0013	.0001	.0365	.1695
-.0199	-.0070	16	.7598	.0086	-.0158	.0013	-.0001	.0057	.1884
-.0200	-.0068	18	.8036	.0100	-.0288	.0002	.0000	.0016	.1983
M = 0.90									
-.0195	-.0132	-4	-.3851	.0152	.0090	.0113	.0001	.0290	-.1865
-.0194	-.0131	-2	-.2324	.0277	.0045	.0099	.0000	.0320	-.1831
-.0193	-.0130	0	-.0927	.0231	.0031	.0097	.0000	.0358	-.1772
-.0193	-.0129	2	.0443	.0210	.0038	.0090	-.0001	.0396	-.1695
-.0192	-.0126	4	.1840	.0142	.0031	.0085	.0004	.0434	-.1534
-.0191	-.0119	6	.3398	.0052	-.0014	.0079	.0004	.0472	-.1119
-.0186	-.0101	8	.5207	-.0016	-.0211	.0054	-.0007	.0732	-.0034
-.0184	-.0087	10	.6220	.0007	-.0215	.0024	-.0003	.0853	.0754
-.0191	-.0076	12	.6964	.0056	-.0218	.0025	-.0002	.0495	.1390
-.0193	-.0071	14	.7690	.0084	-.0271	-.0036	.0001	.0351	.1729
M = 0.93									
-.0195	-.0136	-4	-.3726	.0200	.0135	.0108	.0001	.0273	-.2063
-.0195	-.0136	-2	-.2255	.0233	.0044	.0098	-.0005	.0273	-.2054
-.0194	-.0135	0	-.0901	.0263	.0041	.0110	-.0002	.0288	-.2022
-.0193	-.0134	2	.0459	.0249	.0052	.0110	.0002	.0340	-.1939
-.0193	-.0132	4	.1948	.0177	.0034	.0104	.0003	.0384	-.1833
-.0193	-.0128	6	.3558	.0100	-.0082	.0094	.0000	.0384	-.1619
-.0190	-.0117	8	.5303	.0037	-.0355	.0070	.0000	.0495	-.0994
-.0183	-.0085	10	.6507	.0049	-.0370	.0026	-.0004	.0864	.0879

TABLE V.- AERODYNAMIC CHARACTERISTICS - Concluded

(d) $\delta_s = -0.020$; $\frac{\delta_d}{\delta_s} = 1.00$

δ_s, corr	δ_d, corr	α, deg	C_N	C_A	C_m	ΔC_l	ΔC_n	$C_{h,s}$	$C_{h,d}$
M = 0.60									
-.0199	-.0216	-4	-.2812	.0113	.0365	.0053	.0012	.0064	-.1578
-.0200	-.0216	-2	-.0589	.0174	-.0075	.0033	.0012	.0039	-.1578
-.0200	-.0215	0	-.0475	.0197	-.0063	.0053	.0012	-.0026	-.1521
-.0201	-.0214	2	.0714	.0185	-.0038	.0056	.0013	-.0052	-.1420
-.0200	-.0213	4	.1899	.0115	-.0033	.0068	.0012	-.0013	-.1263
-.0200	-.0211	6	.3074	.0038	-.0036	.0060	.0009	-.0013	-.1090
-.0201	-.0209	8	.4500	-.0009	-.0120	.0056	.0007	-.0090	-.0890
-.0202	-.0206	10	.5694	-.0060	-.0147	.0041	.0004	-.0155	-.0574
-.0204	-.0201	12	.6708	-.0071	-.0149	.0034	.0003	-.0322	-.0143
-.0206	-.0195	14	.7058	-.0019	.0051	.0029	-.0001	-.0568	.0488
-.0206	-.0189	16	.7542	.0020	-.0046	.0026	-.0002	-.0555	.1148
-.0208	-.0186	18	.7928	.0040	-.0116	.0023	-.0004	-.0709	.1449
-.0208	-.0183	20	.8311	.0070	-.0216	.0000	-.0002	-.0722	.1650
-.0208	-.0182	22	.8406	.0091	-.0268	-.0001	-.0003	-.0696	.1779
-.0206	-.0182	24	.8390	.0112	-.0372	-.0005	-.0002	-.0580	.1837
-.0206	-.0181	26	.8321	.0128	-.0480	.0006	-.0002	-.0503	.1865
M = 0.80									
-.0204	-.0227	-4	-.3101	.0146	-.0095	.0038	.0016	-.0217	-.1817
-.0204	-.0227	-2	-.1789	.0206	-.0070	.0049	.0015	-.0217	-.1798
-.0204	-.0227	0	-.0642	.0235	-.0037	.0057	.0016	-.0261	-.1788
-.0204	-.0225	2	.0574	.0214	-.0009	.0066	.0016	-.0235	-.1662
-.0203	-.0223	4	.1785	.0153	.0004	.0078	.0016	-.0174	-.1537
-.0203	-.0221	6	.3192	.0076	-.0010	.0079	.0018	-.0182	-.1411
-.0204	-.0218	8	.4624	.0044	-.0117	.0078	.0016	-.0226	-.1237
-.0206	-.0213	10	.5822	.0008	-.0148	.0034	.0002	-.0365	-.0889
-.0209	-.0205	12	.6174	.0061	.0012	.0024	.0001	-.0521	-.0367
-.0204	-.0186	14	.7086	.0048	-.0053	.0021	-.0001	-.0261	.0918
-.0204	-.0178	16	.7637	.0063	-.0130	.0014	-.0001	-.0217	.1508
-.0204	-.0175	18	.7919	.0087	-.0244	.0010	-.0001	-.0217	.1653
-.0202	-.0172	20	.8400	.0095	-.0352	.0008	-.0002	-.0130	.1885
-.0201	-.0170	22	.8720	.0101	-.0427	.0008	-.0002	-.0087	.2049
-.0200	-.0167	24	.9013	.0480	-.0563	-.0021	.0002	.0017	.2194
-.0199	-.0166	26	.9096	.0483	-.0693	.0003	.0002	.0061	.2310
M = 0.85									
-.0201	-.0233	-4	-.3176	.0187	-.0084	.0026	.0014	-.0040	-.2062
-.0203	-.0234	-2	-.1848	.0235	-.0067	.0026	.0014	-.0161	-.2133
-.0205	-.0234	0	-.0572	.0253	-.0050	.0034	.0013	-.0258	-.2142
-.0205	-.0233	2	.0673	.0247	-.0010	.0040	.0014	-.0266	-.2062
-.0204	-.0230	4	.1920	.0170	.0024	.0051	.0014	-.0210	-.1900
-.0204	-.0228	6	.3434	.0082	.0041	.0070	.0017	-.0218	-.1766
-.0204	-.0225	8	.4874	.0013	-.0054	.0067	.0008	-.0226	-.1533
-.0205	-.0219	10	.6018	.0010	-.0122	.0055	-.0014	-.0274	-.1192
-.0209	-.0210	12	.6517	.0074	-.0066	.0042	.0003	-.0524	-.0610
-.0200	-.0186	14	.7397	.0066	-.0110	-.0005	.0000	.0008	.0869
-.0199	-.0176	16	.7938	.0076	-.0203	-.0026	-.0001	.0040	.1524
-.0201	-.0172	18	.8323	.0085	-.0319	-.0020	.0000	-.0056	.1730
M = 0.90									
-.0203	-.0238	-4	-.3268	.0196	-.0077	.0030	.0009	-.0167	-.2208
-.0204	-.0239	-2	-.1883	.0260	-.0111	.0037	.0010	-.0205	-.2309
-.0205	-.0240	0	-.0570	.0288	-.0059	.0050	.0008	-.0265	-.2377
-.0205	-.0240	2	.0658	.0263	-.0011	.0061	.0006	-.0258	-.2335
-.0204	-.0238	4	.1941	.0200	.0037	.0073	.0011	-.0205	-.2234
-.0204	-.0236	6	.3499	.0111	.0020	.0077	.0011	-.0212	-.2090
-.0205	-.0233	8	.5260	.0058	-.0217	.0046	.0005	-.0250	-.1922
-.0205	-.0226	10	.6272	.0063	-.0195	.0020	.0004	-.0288	-.1526
-.0211	-.0214	12	.6900	.0074	-.0179	.0032	.0001	-.0583	-.0809
-.0200	-.0182	14	.7678	.0064	-.0236	-.0033	-.0002	.0015	.1037
M = 0.93									
-.0202	-.0240	-4	-.3265	.0240	-.0040	.0041	.0007	-.0088	-.2262
-.0203	-.0242	-2	-.1911	.0298	-.0188	.0049	.0005	-.0132	-.2384
-.0205	-.0244	0	-.0358	.0335	-.0059	.0053	.0008	-.0242	-.2531
-.0206	-.0244	2	.0718	.0290	-.0016	.0076	.0007	-.0301	-.2490
-.0203	-.0242	4	.2098	.0226	.0027	.0088	.0009	-.0176	-.2384
-.0204	-.0239	6	.3627	.0142	-.0026	.0096	.0006	-.0220	-.2221
-.0205	-.0237	8	.5280	.0106	-.0273	.0080	.0009	-.0250	-.2082
-.0207	-.0231	10	.6456	.0128	-.0387	.0018	.0005	-.0367	-.1772

TABLE VI.- AERODYNAMIC CHARACTERISTICS

(a) $\delta_s = -0.050$; $\frac{\delta_d}{\delta_s} = 0$

δ_s, corr	δ_d, corr	α, deg	C_N	C_A	C_m	ΔC_l	ΔC_n	$C_{h,s}$	$C_{h,d}$
M = 0.60									
-.0480	.0000	-4	-.3079	.0145	-.0057	.0061	.0011	.1777	.0000
-.0480	.0000	-2	-.1892	.0212	-.0031	.0068	.0012	.1803	.0000
-.0480	.0000	0	-.0757	.0242	-.0021	.0074	.0015	.1828	.0000
-.0480	.0000	2	.0325	.0235	.0008	.0077	.0018	.1854	.0000
-.0479	.0000	4	.1409	.0181	.0031	.0089	.0021	.1880	.0000
-.0480	.0000	6	.2646	.0105	.0057	.0103	.0017	.1828	.0000
-.0481	.0000	8	.4245	.0050	-.0078	.0056	.0017	.1751	.0000
-.0482	.0000	10	.5719	.0009	-.0136	.0007	.0009	.1597	.0000
-.0485	.0000	12	.6890	.0046	-.0087	.0004	.0010	.1391	.0000
-.0488	.0000	14	.7044	.0035	.0110	.0007	.0001	.1082	.0000
-.0493	.0000	16	.7671	.0041	.0040	-.0028	.0000	.0592	.0000
-.0499	.0000	18	.7903	.0050	-.0077	-.0017	-.0004	.0052	.0000
-.0502	.0000	20	.8287	.0064	-.0142	-.0027	-.0003	-.0180	.0000
-.0503	.0000	22	.8573	.0079	-.0216	-.0052	-.0005	-.0258	.0000
-.0503	.0000	24	.8359	.0101	-.0323	-.0031	-.0005	-.0232	.0000
-.0502	.0000	26	.8341	.0123	-.0453	-.0040	-.0004	-.0180	.0000
M = 0.80									
-.0472	.0000	-4	-.3720	.0149	-.0003	.0108	.0010	.1718	.0000
-.0471	.0000	-2	-.2415	.0215	.0036	.0119	.0013	.1770	.0000
-.0470	.0000	0	-.1207	.0254	.0045	.0122	.0017	.1839	.0000
-.0469	.0000	2	-.0029	.0250	.0070	.0126	.0020	.1874	.0000
-.0469	.0000	4	.1214	.0215	.0099	.0137	.0024	.1909	.0000
-.0469	.0000	6	.2556	.0135	.0100	.0142	.0025	.1874	.0000
-.0470	.0000	8	.4299	.0096	-.0071	.0094	.0022	.1857	.0000
-.0472	.0000	10	.5565	.0122	-.0017	.0086	.0046	.1718	.0000
-.0476	.0000	12	.6328	.0103	.0046	.0043	.0006	.1440	.0000
-.0486	.0000	14	.7070	.0081	-.0106	.0011	.0001	.0850	.0000
-.0495	.0000	16	.7655	.0077	-.0098	-.0008	.0000	.0278	.0000
-.0499	.0000	18	.8003	.0090	-.0214	-.0017	-.0001	.0035	.0000
-.0502	.0000	20	.8444	.0084	-.0325	-.0030	-.0002	-.0104	.0000
-.0501	.0000	22	.9048	.0089	-.0384	-.0008	-.0003	-.0087	.0000
-.0500	.0000	24	.9007	.0103	-.0528	-.0025	-.0001	-.0017	.0000
-.0499	.0000	26	.8984	.0107	-.0658	-.0012	-.0002	.0035	.0000
M = 0.85									
-.0466	.0000	-4	-.4024	.0144	.0048	.0139	.0011	.1957	.0000
-.0465	.0000	-2	-.2666	.0228	.0074	.0133	.0014	.2006	.0000
-.0464	.0000	0	-.1361	.0265	.0076	.0140	.0018	.2070	.0000
-.0463	.0000	2	-.0118	.0264	.0094	.0143	.0022	.2103	.0000
-.0463	.0000	4	.1191	.0217	.0119	.0162	.0026	.2135	.0000
-.0464	.0000	6	.2616	.0132	.0125	.0175	.0025	.2070	.0000
-.0465	.0000	8	.4158	.0074	.0051	.0145	.0033	.1973	.0000
-.0467	.0000	10	.5657	.0124	-.0043	.0098	.0018	.1892	.0000
-.0471	.0000	12	.6465	.0126	-.0005	.0049	.0008	.1650	.0000
-.0482	.0000	14	.7222	.0105	-.0033	.0020	.0003	.1035	.0000
-.0494	.0000	16	.7667	.0096	-.0182	.0003	.0000	.0356	.0000
M = 0.90									
-.0463	.0000	-4	-.4561	.0194	.0332	.0179	.0017	.2008	.0000
-.0462	.0000	-2	-.3053	.0255	.0210	.0171	.0016	.2038	.0000
-.0459	.0000	0	-.1518	.0258	.0168	.0174	.0020	.2175	.0000
-.0458	.0000	2	-.0276	.0285	.0154	.0178	.0026	.2251	.0000
-.0458	.0000	4	.1124	.0236	.0167	.0195	.0029	.2266	.0000
-.0458	.0000	6	.2663	.0155	.0168	.0218	.0026	.2236	.0000
-.0486	.0000	8	.4409	.0090	.0040	.0177	.0013	.0745	.0000
-.0457	.0000	10	.5883	.0120	-.0104	.0072	.0007	.2327	.0000
-.0468	.0000	12	.6900	.0107	-.0132	.0038	.0003	.1703	.0000
M = 0.93									
-.0458	.0000	-4	-.4673	.0255	.0513	.0190	.0022	.2196	.0000
-.0456	.0000	-2	-.3182	.0316	.0387	.0189	.0024	.2285	.0000
-.0454	.0000	0	-.1734	.0334	.0297	.0193	.0025	.2403	.0000
-.0452	.0000	2	-.0256	.0323	.0197	.0197	.0027	.2476	.0000
-.0452	.0000	4	.1176	.0268	.0185	.0201	.0029	.2506	.0000
-.0453	.0000	6	.2800	.0177	.0162	.0223	.0022	.2432	.0000
-.0451	.0000	8	.4589	.0140	-.0074	.0176	.0000	.2550	.0000
-.0449	.0000	10	.6062	.0160	-.0177	.0113	.0013	.2653	.0000

TABLE VI.- AERODYNAMIC CHARACTERISTICS - Continued

(b) $\delta_s = -0.050$; $\frac{\delta d}{\delta s} = 0.10$

$\delta_{s,corr}$	$\delta_{d,corr}$	α , deg	C_N	C_A	C_m	ΔC_l	ΔC_n	$C_{h,s}$	$C_{h,d}$
M = 0.60									
-.0484	-.0050	-4	-.3338	.0142	-.0013	.0112	.0014	.1411	.0000
-.0484	-.0049	-2	-.2300	.0209	.0004	.0128	.0013	.1462	.0057
-.0483	-.0048	0	-.1170	.0260	.0031	.0136	.0019	.1552	.0243
-.0482	-.0046	2	.0010	.0253	.0060	.0135	.0020	.1629	.0399
-.0482	-.0045	4	.1153	.0207	.0293	.0152	.0022	.1642	.0457
-.0482	-.0044	6	.2362	.0123	.0091	.0147	.0019	.1642	.0585
-.0482	-.0042	8	.3959	.0069	-.0031	.0113	.0017	.1603	.0827
-.0483	-.0039	10	.5467	.0016	-.0118	.0056	.0011	.1513	.1070
-.0485	-.0037	12	.6773	-.0013	-.0115	.0035	.0010	.1321	.1256
-.0489	-.0033	14	.7170	.0029	.0084	.0027	.0003	.0962	.1655
-.0493	-.0031	16	.7555	.0063	.0018	.0030	.0001	.0590	.1840
-.0498	-.0030	18	.7885	.0072	-.0103	.0028	-.0002	.0180	.1955
-.0501	-.0029	20	.8267	.0080	-.0168	.0004	-.0001	-.0051	.2054
-.0501	-.0029	22	.8358	.0101	-.0228	-.0001	-.0002	-.0103	.2083
-.0501	-.0029	24	.8336	.0128	-.0340	-.0012	-.0002	-.0064	.2097
-.0500	-.0028	26	.8320	.0143	-.0490	.0006	-.0002	-.0038	.2126
M = 0.80									
-.0472	-.0053	-4	-.3951	.0154	.0035	.0150	.0013	.1684	-.0183
-.0472	-.0051	-2	-.2682	.0217	.0062	.0162	.0014	.1693	-.0086
-.0471	-.0047	0	-.1416	.0261	.0064	.0157	.0019	.1788	.0183
-.0470	-.0045	2	-.0146	.0257	.0092	.0157	.0021	.1831	.0365
-.0470	-.0043	4	.1026	.0211	.0116	.0174	.0024	.1814	.0452
-.0471	-.0041	6	.2384	.0135	.0108	.0167	.0024	.1779	.0624
-.0472	-.0037	8	.4126	.0083	-.0062	.0138	.0020	.1675	.0865
-.0474	-.0034	10	.5699	.0062	-.0145	.0057	.0010	.1563	.1057
-.0478	-.0028	12	.6242	.0103	.0037	.0069	.0006	.1356	.1441
-.0486	-.0025	14	.6991	.0088	.0025	.0040	.0003	.0838	.1691
-.0495	-.0022	16	.7581	.0085	.0185	.0023	.0001	.0320	.1873
-.0497	-.0021	18	.7876	.0097	-.0228	.0018	-.0001	.0164	.1931
-.0499	-.0020	20	.8517	.0101	-.0321	.0003	-.0001	.0060	.2017
-.0499	-.0019	22	.8664	.0104	-.0407	.0005	-.0002	.0052	.2065
-.0498	-.0018	24	.8817	.0115	-.0523	.0019	-.0002	.0104	.2104
-.0497	-.0018	26	.9053	.0117	-.0681	.0019	-.0002	.0155	.2152
M = 0.85									
-.0469	-.0067	-4	-.4323	.0176	.0095	.0186	.0009	.1779	-.1066
-.0468	-.0066	-2	-.3001	.0256	.0103	.0181	.0012	.1827	-.0967
-.0465	-.0058	0	-.1613	.0296	.0099	.0172	.0015	.1964	-.0484
-.0464	-.0051	2	-.0314	.0285	.0125	.0168	.0017	.2012	-.0045
-.0465	-.0046	4	.0989	.0230	.0139	.0171	.0022	.1988	.0251
-.0466	-.0041	6	.2376	.0139	.0154	.0197	.0025	.1932	.0528
-.0467	-.0037	8	.4000	.0075	.0059	.0183	.0019	.1843	.0788
-.0471	-.0032	10	.5800	.0076	-.0120	.0109	-.0008	.1626	.1119
-.0472	-.0026	12	.6353	.0129	-.0002	.0084	.0008	.1586	.1513
-.0483	-.0022	14	.7050	.0109	-.0035	.0051	.0004	.0958	.1746
-.0493	-.0020	16	.7793	.0101	-.0198	.0006	.0001	.0378	.1872
-.0496	-.0019	18	.8079	.0103	-.0313	.0009	.0000	.0233	.1934
M = 0.90									
-.0461	-.0074	-4	-.4951	.0264	.0445	.0270	.0010	.2098	-.1390
-.0460	-.0072	-2	-.3452	.0311	.0273	.0243	.0007	.2113	-.1264
-.0457	-.0066	0	-.1786	.0335	.0193	.0217	.0010	.2280	-.0935
-.0456	-.0061	2	-.0404	.0319	.0162	.0200	.0011	.2340	-.0640
-.0457	-.0053	4	.0931	.0248	.0168	.0205	.0018	.2272	-.0177
-.0459	-.0042	6	.2517	.0152	.0188	.0205	.0018	.2212	.0455
-.0459	-.0037	8	.4318	.0081	.0055	.0179	.0007	.2212	.0775
-.0457	-.0032	10	.6006	.0106	-.0140	.0066	.0008	.2287	.1079
-.0468	-.0024	12	.6969	.0106	-.0142	.0044	.0003	.1697	.1517
-.0480	-.0020	14	.7469	.0113	-.0156	.0007	.0003	.1076	.1727
M = 0.93									
-.0455	-.0070	-4	-.4916	.0319	.0564	.0280	.0014	.2312	-.1143
-.0455	-.0068	-2	-.3347	.0350	.0424	.0263	.0007	.2327	-.1021
-.0451	-.0062	0	-.1981	.0375	.0371	.0269	.0010	.2510	-.0694
-.0449	-.0059	2	-.0514	.0357	.0259	.0242	.0014	.2613	-.0531
-.0450	-.0057	4	.0963	.0286	.0199	.0238	.0018	.2562	-.0408
-.0453	-.0041	6	.2713	.0170	.0164	.0226	.0012	.2452	.0498
-.0450	-.0033	8	.4629	.0127	-.0108	.0175	.0010	.2562	.0955
-.0443	-.0025	10	.6189	.0176	-.0382	.0053	.0006	.2951	.1429

TABLE VI.- AERODYNAMIC CHARACTERISTICS - Continued

(c) $\delta_s = -0.050$; $\frac{\delta_d}{\delta_s} = 0.20$

δ_s, corr	δ_d, corr	α, deg	C_N	C_A	C_m	ΔC_l	ΔC_n	$C_{h,s}$	$C_{h,d}$
M = 0.60									
-.0488	-.0103	-4	-.3519	.0159	-.0009	.0142	.0014	.1129	-.0285
-.0487	-.0102	-2	-.2338	.0231	.0008	.0145	.0014	.1193	-.0228
-.0485	-.0100	0	-.1158	.0282	.0026	.0152	.0019	.1321	-.0043
-.0484	-.0098	2	.0018	.0286	.0055	.0148	.0021	.1436	.0185
-.0484	-.0097	4	.1156	.0232	.0077	.0174	.0024	.1488	.0285
-.0484	-.0096	6	.2328	.0150	.0078	.0170	.0020	.1488	.0371
-.0485	-.0094	8	.3778	.0086	-.0009	.0143	.0017	.1398	.0571
-.0485	-.0092	10	.5343	.0034	-.0096	.0092	.0012	.1321	.0813
-.0487	-.0089	12	.6641	.0001	-.0120	.0064	.0011	.1141	.1056
-.0498	-.0083	14	.7178	.0035	.0093	.0037	.0003	.0167	.1641
-.0494	-.0080	16	.7520	.0075	.0018	.0051	.0001	.0551	.1983
-.0499	-.0079	18	.7997	.0088	-.0095	.0040	-.0001	.0077	.2112
-.0502	-.0078	20	.8376	.0097	-.0168	.0012	-.0002	-.0218	.2197
-.0503	-.0077	22	.8467	.0112	-.0233	.0007	-.0002	-.0282	.2240
-.0503	-.0077	24	.8453	.0133	-.0340	.0007	-.0001	-.0282	.2240
-.0503	-.0077	26	.8479	.0149	-.0469	.0010	-.0001	-.0231	.2254
M = 0.80									
-.0476	-.0114	-4	-.3937	.0187	.0043	.0172	.0015	.1486	-.0923
-.0475	-.0113	-2	-.2672	.0260	.0058	.0178	.0016	.1547	-.0865
-.0472	-.0107	0	-.1376	.0301	.0060	.0165	.0022	.1728	-.0481
-.0470	-.0103	2	-.0138	.0294	.0085	.0169	.0023	.1823	-.0183
-.0470	-.0100	4	.1136	.0247	.0106	.0181	.0026	.1841	.0010
-.0471	-.0097	6	.2433	.0165	.0116	.0183	.0026	.1763	.0211
-.0473	-.0093	8	.4119	.0113	-.0019	.0166	.0023	.1668	.0481
-.0475	-.0088	10	.5747	.0084	-.0123	.0067	.0011	.1504	.0798
-.0480	-.0079	12	.6289	.0118	.0049	.0079	.0007	.1201	.1394
-.0488	-.0075	14	.7040	.0103	.0024	.0052	.0003	.0752	.1682
-.0496	-.0072	16	.7575	.0099	-.0112	.0035	.0002	.0225	.1855
-.0499	-.0070	18	.8056	.0108	-.0234	.0022	-.0001	.0043	.1980
-.0502	-.0068	20	.8526	.0105	-.0336	.0009	-.0002	-.0095	.2105
-.0502	-.0068	22	.8753	.0109	-.0393	.0023	-.0003	-.0104	.2163
-.0501	-.0065	24	.9149	.0121	-.0567	-.0004	-.0002	-.0035	.2317
-.0500	-.0064	26	.9293	.0124	-.0697	.0010	-.0002	-.0017	.2365
M = 0.85									
-.0469	-.0125	-4	-.4412	.0217	.0107	.0196	.0013	.1763	-.1532
-.0466	-.0123	-2	-.3004	.0289	.0102	.0179	.0015	.1924	-.1424
-.0461	-.0116	0	-.1622	.0329	.0093	.0161	.0018	.2190	-.1021
-.0461	-.0110	2	-.0317	.0315	.0103	.0166	.0020	.2239	-.0618
-.0462	-.0105	4	.0951	.0254	.0120	.0165	.0024	.2166	-.0305
-.0463	-.0100	6	.2374	.0169	.0132	.0195	.0027	.2077	-.0009
-.0464	-.0095	8	.3907	.0099	.0072	.0185	.0020	.2029	.0314
-.0468	-.0086	10	.5585	.0100	-.0085	.0127	-.0005	.1796	.0842
-.0472	-.0078	12	.6297	.0140	.0011	.0090	.0008	.1594	.1344
-.0482	-.0073	14	.7050	.0126	-.0043	.0048	.0004	.1031	.1648
-.0493	-.0071	16	.7642	.0112	-.0192	.0015	.0001	.0395	.1827
-.0495	-.0068	18	.8173	.0113	-.0327	.0003	.0000	.0258	.1989
M = 0.90									
-.0459	-.0130	-4	-.4743	.0275	.0316	.0239	.0013	.2197	-.1762
-.0457	-.0128	-2	-.3320	.0341	.0221	.0225	.0008	.2303	-.1627
-.0454	-.0123	0	-.1848	.0367	.0193	.0216	.0012	.2462	-.1340
-.0452	-.0119	2	-.0460	.0351	.0166	.0205	.0014	.2584	-.1096
-.0452	-.0113	4	.0927	.0286	.0162	.0200	.0020	.2584	-.0767
-.0454	-.0104	6	.2512	.0184	.0157	.0201	.0020	.2447	-.0261
-.0456	-.0097	8	.4173	.0104	.0055	.0186	.0009	.2364	.0177
-.0456	-.0089	10	.5796	.0107	-.0127	.0066	.0007	.2349	.0624
-.0468	-.0077	12	.6824	.0110	-.0129	.0048	.0002	.1690	.1332
-.0480	-.0072	14	.7328	.0120	-.0130	.0015	.0003	.1083	.1660
M = 0.93									
-.0451	-.0127	-4	-.4843	.0349	.0538	.0262	.0016	.2518	-.1543
-.0450	-.0125	-2	-.3369	.0394	.0410	.0236	.0011	.2591	-.1421
-.0446	-.0120	0	-.1986	.0414	.0370	.0263	.0013	.2775	-.1151
-.0445	-.0118	2	-.0572	.0394	.0270	.0243	.0016	.2863	-.1004
-.0445	-.0116	4	.0959	.0317	.0210	.0231	.0020	.2848	-.0890
-.0447	-.0109	6	.2651	.0216	.0146	.0225	.0014	.2723	-.0482
-.0451	-.0098	8	.4305	.0135	-.0034	.0206	.0009	.2554	.0098
-.0448	-.0081	10	.6066	.0146	-.0271	.0074	.0004	.2701	.1053

TABLE VI.- AERODYNAMIC CHARACTERISTICS - Continued

(d) $\delta_s = -0.050$; $\frac{\delta_d}{\delta_s} = 0.40$

$\delta_{s,corr}$	$\delta_{d,corr}$	α , deg	C_N	C_A	C_m	ΔC_l	ΔC_n	$C_{h,s}$	$C_{h,d}$
M = 0.60									
-.0484	-.0209	-4	-.3614	.0207	-.0006	.0150	.0020	.1487	-.0841
-.0481	-.0207	-2	-.2386	.0279	-.0007	.0149	.0019	.1692	-.0670
-.0479	-.0204	0	-.1161	.0324	.0011	.0148	.0025	.1872	-.0399
-.0478	-.0202	2	.0010	.0316	.0032	.0137	.0026	.1974	-.0157
-.0478	-.0199	4	.1147	.0257	.0054	.0164	.0028	.2000	.0057
-.0478	-.0197	6	.2454	.0176	.0069	.0335	.0023	.2000	.0257
-.0479	-.0195	8	.3826	.0113	-.0014	.0140	.0020	.1872	.0456
-.0482	-.0192	10	.5237	.0050	-.0084	.0089	.0014	.1641	.0827
-.0484	-.0191	12	.6433	.0010	-.0120	.0063	.0012	.1474	.0884
-.0485	-.0184	14	.6739	.0079	.0113	.0068	.0009	.1372	.1540
-.0487	-.0180	16	.7466	.0085	.0026	.0051	.0003	.1141	.1954
-.0492	-.0178	18	.7885	.0082	-.0086	.0031	.0000	.0705	.2139
-.0496	-.0177	20	.8413	.0096	-.0160	-.0002	-.0001	.0359	.2268
-.0497	-.0176	22	.8504	.0106	-.0224	-.0008	-.0001	.0308	.2325
-.0496	-.0176	24	.8538	.0138	-.0336	-.0012	.0000	.0333	.2382
-.0495	-.0176	26	.8466	.0153	-.0448	-.0005	.0001	.0410	.2396
M = 0.80									
-.0470	-.0218	-4	-.3999	-.0140	.0049	.0176	.0016	.1831	-.1201
-.0467	-.0215	-2	-.2683	.0295	.0051	.0163	.0020	.1996	-.0999
-.0465	-.0211	0	-.1416	.0329	.0053	.0159	.0025	.2151	-.0740
-.0464	-.0208	2	-.0214	.0322	.0076	.0161	.0026	.2203	-.0500
-.0463	-.0205	4	.0993	.0272	.0091	.0177	.0029	.2220	-.0317
-.0464	-.0202	6	.2392	.0190	.0098	.0177	.0028	.2177	-.0115
-.0467	-.0197	8	.3974	.0135	-.0025	.0160	.0025	.2004	.0173
-.0471	-.0194	10	.5436	.0099	-.0137	.0071	.0012	.1788	.0413
-.0473	-.0184	12	.5983	.0130	.0057	.0088	.0008	.1624	.1076
-.0480	-.0177	14	.6867	.0114	.0033	.0054	.0005	.1244	.1518
-.0486	-.0172	16	.7923	.0122	-.0104	.0495	.0002	.0838	.1855
-.0491	-.0170	18	.7945	.0111	-.0220	.0014	.0000	.0570	.1999
-.0493	-.0167	20	.8488	.0109	-.0307	.0005	-.0001	.0432	.2172
-.0493	-.0166	22	.8610	.0109	-.0393	.0020	-.0002	.0432	.2230
-.0493	-.0164	24	.8827	.0121	-.0811	.0007	-.0001	.0449	.2364
-.0492	-.0163	26	.8990	.0125	-.0667	.0022	-.0001	.0492	.2460
M = 0.85									
-.0464	-.0223	-4	-.4296	.0246	.0084	.0180	.0016	.2045	-.1424
-.0471	-.0223	-2	-.2974	.0325	.0087	.0175	.0018	.1666	-.1406
-.0458	-.0219	0	-.1581	.0359	.0097	.0171	.0020	.2367	-.1209
-.0457	-.0215	2	-.0313	.0345	.0107	.0170	.0023	.2415	-.0931
-.0458	-.0210	4	.0926	.0284	.0116	.0175	.0026	.2407	-.0600
-.0458	-.0205	6	.2404	.0193	.0118	.0195	.0029	.2359	-.0304
-.0461	-.0201	8	.3878	.0109	.0064	.0192	.0020	.2206	-.0054
-.0466	-.0194	10	.5520	.0097	-.0107	.0140	-.0006	.1948	.0385
-.0467	-.0184	12	.6173	.0144	.0025	.0099	.0008	.1851	.1012
-.0476	-.0176	14	.6997	.0130	-.0016	.0064	.0004	.1368	.1478
-.0484	-.0171	16	.7683	-.0052	-.0178	.0027	.0000	.0926	.1818
-.0489	-.0168	18	.8275	-.0055	-.0299	.0011	-.0001	.0620	.1988
M = 0.90									
-.0456	-.0228	-4	-.4582	.0310	.0238	.0219	.0015	.2349	-.1652
-.0453	-.0228	-2	-.3147	.0377	.0207	.0215	.0012	.2485	-.1618
-.0450	-.0224	0	-.1708	.0388	.0166	.0203	.0014	.2644	-.1374
-.0449	-.0221	2	-.0376	.0379	.0165	.0198	.0016	.2728	-.1205
-.0449	-.0218	4	.0930	.0321	.0166	.0204	.0023	.2713	-.1037
-.0450	-.0213	6	.2459	.0215	.0163	.0209	.0023	.2667	-.0742
-.0452	-.0206	8	.4120	.0123	.0062	.0195	.0011	.2569	-.0379
-.0452	-.0199	10	.5736	.0120	-.0152	.0068	.0007	.2553	.0084
-.0463	-.0186	12	.6713	.0127	-.0104	.0059	.0004	.1970	.0834
-.0473	-.0175	14	.7353	.0126	-.0143	.0010	.0003	.1424	.1483
M = 0.93									
-.0448	-.0232	-4	-.4685	.0388	.0437	.0248	.0019	.2679	-.1813
-.0447	-.0231	-2	-.3312	.0451	.0333	.0241	.0015	.2745	-.1772
-.0445	-.0227	0	-.1889	.0433	.0270	.0245	.0014	.2833	-.1519
-.0444	-.0224	2	-.0496	.0408	.0220	.0230	.0017	.2877	-.1347
-.0443	-.0221	4	.0847	.0345	.0222	.0237	.0022	.2936	-.1192
-.0444	-.0216	6	.2518	.0245	.0167	.0240	.0017	.2885	-.0923
-.0447	-.0210	8	.4202	.0142	-.0009	.0223	.0011	.2716	-.0539
-.0444	-.0200	10	.5902	.0160	-.0283	.0092	.0004	.2914	-.0008

TABLE VI.- AERODYNAMIC CHARACTERISTICS - Concluded

(e) $\delta_s = -0.050$; $\frac{\delta_d}{\delta_s} = 1.00$

δ_s, corr	δ_d, corr	α, deg	C_N	C_A	C_m	ΔC_l	ΔC_n	$C_{h,s}$	$C_{h,d}$
M = 0.80									
-.0486	-.0515	-4	-.3447	.0375	-.0056	.0109	.0037	.1258	-.2027
-.0485	-.0516	-2	-.2356	.0448	-.0000	.0124	.0037	.1335	-.2099
-.0485	-.0516	0	-.1361	.0490	.0053	.0152	.0042	.1386	-.2113
-.0484	-.0516	2	-.0371	.0479	.0113	.0169	.0042	.1437	-.2084
-.0483	-.0515	4	.0769	.0425	.0161	.0196	.0045	.1502	-.2013
-.0483	-.0514	6	-.0633	.0348	.0186	.0243	.0040	.1553	-.1885
-.0477	-.0513	8	.3211	.0271	.0090	.0194	.0036	.2092	-.1799
-.0485	-.0512	10	.4581	.0198	.0012	.0154	.0028	.1360	-.1599
-.0487	-.0510	12	.5915	.0146	-.0054	.0109	.0026	.1206	-.1328
-.0490	-.0507	14	.6316	.0167	.0138	.0107	.0017	.0911	-.0885
-.0493	-.0504	16	.6995	.0152	.0073	.0091	.0010	.0667	-.0600
-.0497	-.0503	18	.7505	.0181	-.0036	.0055	.0006	.0257	-.0385
-.0501	-.0502	20	.8205	.0112	-.0186	-.0016	.0001	-.0128	-.0271
-.0503	-.0502	22	.8450	.0122	-.0238	-.0022	.0000	-.0308	-.0243
-.0503	-.0502	24	.8343	.0154	-.0337	-.0011	.0001	-.0295	-.0228
-.0503	-.0501	26	.8428	.0159	-.0422	-.0001	.0001	-.0270	-.0128
M = 0.80									
-.0477	-.0524	-4	-.3665	.0414	-.0052	.0088	.0042	.1427	-.2136
-.0475	-.0525	-2	-.2612	.0490	.0017	.0127	.0042	.1496	-.2270
-.0474	-.0526	0	-.1528	.0538	.0087	.0146	.0047	.1582	-.2376
-.0473	-.0526	2	-.0409	.0528	.0159	.0169	.0047	.1617	-.2357
-.0473	-.0526	4	.0607	.0473	.0204	.0202	.0050	.1626	-.2318
-.0474	-.0525	6	.1815	.0394	.0238	.0219	.0051	.1591	-.2280
-.0476	-.0524	8	.3338	.0353	.0100	.0215	.0050	.1479	-.2184
-.0478	-.0522	10	.4832	.0289	-.0013	.0121	.0033	.1332	-.2011
-.0485	-.0518	12	.5229	.0300	.0240	.0162	.0025	.0934	-.1606
-.0490	-.0514	14	.6036	.0252	.0173	.0123	.0018	.0631	-.1241
-.0497	-.0512	16	.6996	.0218	.0022	.0073	.0012	.0190	-.1049
-.0502	-.0511	18	.7558	.0192	-.0131	.0032	.0009	-.0121	-.0972
-.0505	-.0510	20	.8096	.0175	-.0261	.0020	.0006	-.0329	-.0866
-.0506	-.0508	22	.8406	.0163	-.0362	.0009	.0002	-.0363	-.0693
-.0505	-.0506	24	.8851	.0168	-.0461	.0050	.0002	-.0294	-.0577
-.0504	-.0505	26	.8634	.0155	-.0593	.0035	.0000	-.0259	-.0414
M = 0.85									
-.0474	-.0528	-4	-.3865	.0439	-.0037	.0088	.0039	.1466	-.2357
-.0473	-.0529	-2	-.2705	.0522	.0043	.0114	.0041	.1539	-.2474
-.0472	-.0531	0	-.1573	.0569	.0119	.0140	.0043	.1612	-.2573
-.0471	-.0530	2	-.0473	.0559	.0200	.0164	.0045	.1652	-.2555
-.0470	-.0530	4	.0654	.0504	.0237	.0186	.0049	.1684	-.2492
-.0471	-.0529	6	.1929	.0419	.0266	.0230	.0054	.1636	-.2438
-.0473	-.0528	8	.3313	.0355	.0176	.0237	.0050	.1507	-.2348
-.0479	-.0525	10	.4647	.0336	.0067	.0147	.0020	.1168	-.2089
-.0483	-.0522	12	.5230	.0334	.0222	.0189	.0029	.0959	-.1838
-.0489	-.0518	14	.6071	.0289	.0159	.0135	.0020	.0637	-.1479
-.0498	-.0515	16	.7065	.0240	.0132	.0068	.0013	.0137	-.1246
-.0505	-.0513	18	.7547	.0203	-.0164	.0048	.0010	-.0266	-.1103
M = 0.90									
-.0472	-.0532	-4	-.3996	.0479	-.0011	.0107	.0035	.1495	-.2499
-.0471	-.0533	-2	-.2746	.0555	.0040	.0127	.0035	.1563	-.2634
-.0470	-.0534	0	-.1568	.0573	.0123	.0156	.0037	.1594	-.2676
-.0469	-.0534	2	-.0504	.0590	.0217	.0184	.0040	.1670	-.2719
-.0468	-.0534	4	.0622	.0370	.0280	.0223	.0045	.1708	-.2659
-.0469	-.0532	6	.2013	.0436	.0313	.0242	.0047	.1677	-.2567
-.0469	-.0532	8	.3571	.0381	.0229	.0245	.0042	.1677	-.2550
-.0470	-.0531	10	.5063	.0375	.0086	.0146	.0038	.1586	-.2474
-.0483	-.0526	12	.5514	.0355	.0199	.0196	.0030	.0903	-.2068
M = 0.93									
-.0471	-.0532	-4	-.4004	.0511	.0025	.0112	.0031	.1485	-.2470
-.0470	-.0535	-2	-.2739	.0593	.0056	.0139	.0034	.1544	-.2675
-.0469	-.0535	0	-.1515	.0631	.0148	.0173	.0038	.1618	-.2716
-.0468	-.0536	2	-.0433	.0626	.0228	.0198	.0042	.1662	-.2740
-.0467	-.0535	4	.0737	.0553	.0290	.0240	.0045	.1706	-.2716
-.0467	-.0534	6	.2082	.0461	.0319	.0266	.0041	.1706	-.2642
-.0467	-.0534	8	.3777	.0404	.0171	.0256	.0040	.1706	-.2617
-.0468	-.0534	10	.5116	.0417	.0040	.0175	.0035	.1632	-.2576

TABLE VII.- AERODYNAMIC CHARACTERISTICS

(a) $\delta_s = -0.075$; $\frac{\delta_d}{\delta_s} = 0$

δ_s, corr	δ_d, corr	α, deg	C_N	C_A	C_m	ΔC_l	ΔC_n	$C_{h,s}$	$C_{h,d}$
M = 0.80									
-.0724	.0000	-4	-.3866	.0268	.0008	.0173	.0026	.2810	.0000
-.0725	.0000	-2	-.2633	.0335	.0035	.0172	.0026	.2758	.0000
-.0725	.0000	0	-.1618	.0388	-.0169	.0173	.0032	.2758	.0000
-.0724	.0000	2	-.0360	.0401	.0073	.0184	.0036	.2810	.0000
-.0724	.0000	4	.0725	.0368	.0094	.0197	.0042	.2810	.0000
-.0724	.0000	6	.1912	.0281	.0126	.0208	.0037	.2810	.0000
-.0726	.0000	8	.3558	.0216	-.0013	.0156	.0034	.2578	.0000
-.0730	.0000	10	.5220	.0141	-.0113	.0085	.0024	.2165	.0000
-.0731	.0000	12	.6354	.0117	-.0035	.0097	.0011	.2037	.0000
-.0738	.0000	14	.6736	.0091	.0092	.0067	.0006	.1289	.0000
-.0732	.0000	16	.7453	.0081	.0027	.0015	.0003	.1959	.0000
-.0751	.0000	18	.7928	.0056	-.0103	.0006	-.0002	-.0129	.0000
-.0754	.0000	20	.8311	.0054	-.0147	-.0006	-.0005	-.0412	.0000
-.0754	.0000	22	.8498	.0075	-.0225	-.0026	-.0005	-.0490	.0000
-.0754	.0000	24	.8388	.0097	-.0341	-.0004	-.0005	-.0438	.0000
-.0754	.0000	26	.8322	.0124	-.0457	-.0009	-.0004	-.0387	.0000
M = 0.80									
-.0708	.0000	-4	-.4468	.0270	.0075	.0214	.0022	.3126	.0000
-.0709	.0000	-2	-.3164	.0358	.0108	.0222	.0026	.3004	.0000
-.0709	.0000	0	-.1887	.0407	.0115	.0225	.0034	.3004	.0000
-.0709	.0000	2	-.0747	.0417	.0131	.0223	.0038	.3039	.0000
-.0709	.0000	4	.0499	.0374	.0149	.0238	.0044	.3056	.0000
-.0710	.0000	6	.1777	.0302	.0163	.0249	.0045	.2969	.0000
-.0710	.0000	8	.3652	.0263	.0001	.0191	.0039	.2952	.0000
-.0715	.0000	10	.4973	.0255	-.0010	.0123	.0057	.2553	.0000
-.0723	.0000	12	.6053	.0199	.0027	.0087	.0014	.1997	.0000
-.0735	.0000	14	.6909	.0137	.0033	.0056	.0005	.1111	.0000
-.0749	.0000	16	.7438	.0097	-.0133	.0023	.0001	.0087	.0000
-.0753	.0000	18	.7924	.0084	-.0229	.0010	-.0003	-.0208	.0000
-.0755	.0000	20	.8394	.0081	-.0322	-.0012	-.0003	-.0365	.0000
-.0755	.0000	22	.8306	.0088	-.0394	.0013	-.0003	-.0347	.0000
-.0754	.0000	24	.9190	.0103	-.0555	-.0019	-.0001	-.0295	.0000
-.0754	.0000	26	.9006	.0107	-.0656	.0008	-.0001	-.0278	.0000
M = 0.85									
-.0702	.0000	-4	-.4865	.0285	.0146	.0254	.0025	.3317	.0000
-.0704	.0000	-2	-.3386	.0372	.0154	.0239	.0028	.3155	.0000
-.0704	.0000	0	-.2051	.0428	.0155	.0244	.0035	.3139	.0000
-.0704	.0000	2	-.0808	.0433	.0161	.0248	.0043	.3187	.0000
-.0703	.0000	4	.0410	.0399	.0176	.0273	.0048	.3236	.0000
-.0704	.0000	6	.1811	.0319	.0188	.0299	.0033	.3139	.0000
-.0706	.0000	8	.3436	.0260	.0071	.0255	.0039	.2993	.0000
-.0709	.0000	10	.5023	.0282	-.0003	.0193	.0035	.2848	.0000
-.0718	.0000	12	.6148	.0229	-.0017	.0097	.0017	.2200	.0000
-.0731	.0000	14	.6939	.0158	-.0022	.0069	.0007	.1278	.0000
-.0748	.0000	16	.7681	.0109	-.0214	.0021	.0002	.0162	.0000
M = 0.90									
-.0697	.0000	-4	-.5368	.0362	.0547	.0302	.0036	.3441	.0000
-.0699	.0000	-2	-.4019	.0425	.0387	.0285	.0034	.3319	.0000
-.0698	.0000	0	-.2341	.0468	.0280	.0281	.0040	.3380	.0000
-.0697	.0000	2	-.0943	.0477	.0242	.0293	.0033	.3456	.0000
-.0697	.0000	4	.0361	.0424	.0228	.0303	.0052	.3456	.0000
-.0698	.0000	6	.1816	.0337	.0227	.0333	.0050	.3349	.0000
-.0699	.0000	8	.3543	.0290	.0088	.0306	.0042	.3304	.0000
-.0698	.0000	10	.5207	.0290	-.0055	.0169	.0034	.3349	.0000
-.0712	.0000	12	.6367	.0228	-.0055	.0121	.0017	.2436	.0000
M = 0.93									
-.0691	.0000	-4	-.5141	.0427	.0612	.0266	.0043	.3673	.0000
-.0692	.0000	-2	-.3594	.0519	.0457	.0262	.0045	.3643	.0000
-.0691	.0000	0	-.2260	.0521	.0342	.0272	.0048	.3717	.0000
-.0689	.0000	2	-.0840	.0524	.0224	.0276	.0052	.3835	.0000
-.0690	.0000	4	.0479	.0454	.0194	.0289	.0054	.3791	.0000
-.0692	.0000	6	.1998	.0370	.0184	.0325	.0048	.3643	.0000
-.0690	.0000	8	.3756	.0327	.0047	.0303	.0028	.3761	.0000

TABLE VII.- AERODYNAMIC CHARACTERISTICS - Continued

(b) $\delta_s = -0.075$; $\frac{\delta_d}{\delta_s} = 0.07$

δ_s, corr	δ_d, corr	α, deg	C_N	C_A	C_m	ΔC_l	ΔC_n	$C_{h,s}$	$C_{h,d}$
M = 0.60									
-.0728	-.0048	-4	-.3942	.0281	-.0005	.0185	.0028	.2386	.0245
-.0728	-.0047	-2	-.2749	.0343	.0018	.0184	.0026	.2464	.0332
-.0727	-.0045	0	-.1555	.0411	.0031	.0192	.0034	.2516	.0476
-.0726	-.0044	2	-.0463	.0414	.0064	.0194	.0037	.2593	.0620
-.0726	-.0043	4	.0631	.0382	.0096	.0212	.0038	.2593	.0721
-.0726	-.0042	6	.1778	.0294	.0105	.0224	.0037	.2593	.0808
-.0728	-.0040	8	.3387	.0224	.0009	.0180	.0032	.2412	.0995
-.0731	-.0038	10	.5115	.0149	-.0091	.0116	.0024	.2127	.1183
-.0734	-.0037	12	.6425	.0097	-.0080	.0081	.0022	.1764	.1356
-.0739	-.0033	14	.6976	.0107	.0093	.0068	.0009	.1245	.1717
-.0744	-.0032	16	.7505	.0098	.0018	.0050	.0003	.0648	.1832
-.0751	-.0031	18	.8073	.0083	-.0117	.0018	-.0001	-.0130	.1890
-.0754	-.0030	20	.8467	.0076	-.0170	.0002	-.0004	-.0467	.2034
-.0754	-.0029	22	.8508	.0097	-.0235	-.0003	-.0004	-.0493	.2063
-.0754	-.0030	24	.8491	.0119	-.0343	-.0006	-.0003	-.0493	.2048
-.0754	-.0029	26	.8371	.0135	-.0474	.0009	-.0003	-.0467	.2077
M = 0.80									
-.0713	-.0050	-4	-.4475	.0276	-.0081	.0223	.0024	.2725	-.0010
-.0713	-.0049	-2	-.3186	.0360	.0088	.0227	.0026	.2725	.0087
-.0712	-.0046	0	-.1940	.0416	.0095	.0222	.0034	.2813	.0291
-.0711	-.0043	2	-.0718	.0423	.0118	.0230	.0038	.2900	.0486
-.0711	-.0041	4	.0400	.0387	.0147	.0246	.0044	.2917	.0593
-.0712	-.0039	6	.1751	.0301	.0161	.0254	.0043	.2830	.0758
-.0715	-.0036	8	.3471	.0234	-.0004	.0214	.0034	.2620	.0962
-.0721	-.0034	10	.5304	.0150	-.0174	.0091	.0012	.2131	.1069
-.0724	-.0028	12	.6090	.0201	.0013	.0093	.0012	.1922	.1496
-.0734	-.0025	14	.6911	.0142	.0016	.0053	.0006	.1205	.1691
-.0748	-.0023	16	.7488	.0105	-.0142	.0037	.0001	.0175	.1827
-.0751	-.0022	18	.7865	.0099	-.0236	.0017	-.0002	-.0087	.1914
-.0753	-.0021	20	.8415	.0093	-.0324	.0008	-.0003	-.0245	.1982
-.0754	-.0020	22	.8678	.0096	-.0388	.0020	-.0004	-.0297	.2021
-.0754	-.0019	24	.8754	.0113	-.0514	.0022	-.0003	-.0280	.2070
-.0754	-.0019	26	.9130	.0119	-.0675	.0019	-.0001	-.0262	.2108
M = 0.85									
-.0709	-.0067	-4	-.4997	.0316	.0166	.0259	.0053	.2867	-.1051
-.0708	-.0064	-2	-.3599	.0415	.0153	.0252	.0026	.2916	-.0870
-.0705	-.0058	0	-.2320	.0470	.0150	.0248	.0031	.3111	-.0535
-.0704	-.0050	2	-.0968	.0464	.0162	.0249	.0036	.3176	-.0018
-.0704	-.0044	4	.0220	.0413	.0177	.0251	.0042	.3176	.0362
-.0706	-.0042	6	.1660	.0321	.0192	.0281	.0046	.3046	.0516
-.0709	-.0036	8	.1598	.0258	.0079	.0294	.0039	.2867	.0888
-.0717	-.0032	10	.5241	.0172	-.0163	.0107	-.0002	.2313	.1123
-.0719	-.0026	12	.6118	.0217	-.0044	.0102	.0014	.2134	.1540
-.0729	-.0022	14	.7039	.0172	-.0050	.0050	.0006	.1466	.1749
-.0746	-.0021	16	.7576	.0117	-.0221	.0021	.0002	.0293	.1839
-.0750	-.0020	18	.8083	.0105	-.0330	.0011	-.0001	.0016	.1903
M = 0.90									
-.0702	-.0068	-4	-.5588	.0416	.0561	.0351	.0026	.3158	-.1083
-.0702	-.0065	-2	-.4121	.0475	.0427	.0335	.0021	.3128	-.0912
-.0700	-.0062	0	-.2588	.0514	.0293	.0311	.0027	.3266	-.0733
-.0698	-.0059	2	-.1187	.0503	.0240	.0297	.0031	.3404	-.0546
-.0697	-.0050	4	.0217	.0446	.0216	.0291	.0040	.3434	-.0017
-.0700	-.0039	6	.1681	.0343	.0218	.0308	.0041	.3235	.0682
-.0701	-.0034	8	.3366	.0283	.0102	.0297	.0036	.3220	.0955
-.0701	-.0029	10	.5141	.0270	-.0093	.0151	.0029	.3220	.1228
-.0709	-.0023	12	.6459	.0241	-.0094	.0095	.0016	.2668	.1612
-.0725	-.0021	14	.7327	.0180	-.0171	.0016	.0008	.1641	.1740
M = 0.93									
-.0694	-.0064	-4	-.5459	.0460	.0641	.0343	.0027	.3565	-.0793
-.0694	-.0061	-2	-.3980	.0522	.0505	.0338	.0023	.3535	-.0628
-.0693	-.0058	0	-.2636	.0561	.0381	.0337	.0029	.3609	-.0446
-.0692	-.0056	2	-.1228	.0519	.0294	.0322	.0033	.3654	-.0364
-.0691	-.0052	4	.0209	.0479	.0228	.0318	.0039	.3713	-.0132
-.0693	-.0036	6	.1706	.0362	.0193	.0336	.0036	.3580	.0793
-.0691	-.0028	8	.3737	.0347	-.0040	.0282	.0040	.3728	.1248
-.0693	-.0025	10	.5257	.0306	-.0141	.0185	.0027	.3609	.1438

TABLE VII.- AERODYNAMIC CHARACTERISTICS - Continued

(c) $\delta_s = -0.075$; $\frac{\delta_d}{\delta_s} = 0.13$

δ_s, corr	δ_d, corr	α, deg	C_N	C_A	C_m	ΔC_l	ΔC_n	$C_{h,s}$	$C_{h,d}$
M = 0.60									
-0.0726	-0.0100	-4	-0.4136	0.0287	-0.0005	0.0202	0.0028	0.2593	0.0043
-0.0726	-0.0099	-2	-0.2943	0.0355	0.0022	0.0201	0.0026	0.2593	0.0115
-0.0725	-0.0097	0	-0.1800	0.0412	0.0040	0.0210	0.0034	0.2723	0.0289
-0.0724	-0.0095	2	-0.0704	0.0427	0.0060	0.0218	0.0037	0.2827	0.0476
-0.0723	-0.0094	4	0.0435	0.0388	0.0095	0.0227	0.0043	0.2931	0.0620
-0.0724	-0.0093	6	0.1583	0.0306	0.0105	0.0241	0.0038	0.2879	0.0678
-0.0726	-0.0092	8	0.3048	0.0231	0.0031	0.0209	0.0035	0.2697	0.0837
-0.0728	-0.0090	10	0.4671	0.0156	-0.0078	0.0144	0.0024	0.2464	0.1039
-0.0731	-0.0087	12	0.6127	0.0104	-0.0101	0.0100	0.0022	0.2075	0.1269
-0.0733	-0.0082	14	0.6627	0.0146	0.0079	0.0087	0.0015	0.1867	0.1760
-0.0740	-0.0081	16	0.7153	0.0116	0.0018	0.0065	0.0005	0.1141	0.1904
-0.0747	-0.0079	18	0.7829	0.0084	-0.0104	0.0036	-0.0001	0.0337	0.2106
-0.0750	-0.0078	20	0.8263	0.0082	-0.0156	0.0005	-0.0003	0.0026	0.2164
-0.0750	-0.0078	22	0.8356	0.0098	-0.0235	0.0003	-0.0003	-0.0026	0.2164
-0.0750	-0.0078	24	0.8190	0.0125	-0.0330	0.0005	-0.0002	-0.0000	0.2164
-0.0749	-0.0078	26	0.8224	0.0141	-0.0452	0.0018	-0.0002	0.0078	0.2164
M = 0.80									
-0.0718	-0.0111	-4	-0.4708	0.0306	0.0069	0.0235	0.0026	0.2362	-0.0759
-0.0717	-0.0110	-2	-0.3424	0.0402	0.0092	0.0243	0.0030	0.2450	-0.0681
-0.0715	-0.0106	0	-0.2143	0.0450	0.0089	0.0235	0.0037	0.2625	-0.0419
-0.0714	-0.0102	2	-0.0922	0.0457	0.0111	0.0240	0.0041	0.2712	-0.0107
-0.0713	-0.0098	4	0.0264	0.0414	0.0138	0.0251	0.0046	0.2765	0.0117
-0.0715	-0.0095	6	0.1552	0.0327	0.0149	0.0264	0.0045	0.2607	0.0331
-0.0718	-0.0091	8	0.3214	0.0250	0.0032	0.0233	0.0035	0.2362	0.0623
-0.0722	-0.0086	10	0.5084	0.0204	-0.0161	0.0108	0.0024	0.2065	0.0983
-0.0728	-0.0080	12	0.5791	0.0206	0.0013	0.0099	0.0013	0.1662	0.1372
-0.0738	-0.0076	14	0.6720	0.0154	0.0013	0.0062	0.0006	0.0927	0.1625
-0.0750	-0.0073	16	0.7290	0.0117	-0.0148	0.0036	0.0002	-0.0017	0.1801
-0.0754	-0.0071	18	0.7915	0.0107	-0.0237	0.0017	-0.0002	-0.0332	0.1956
-0.0757	-0.0069	20	0.8392	0.0093	-0.0325	0.0005	-0.0003	-0.0490	0.2083
-0.0757	-0.0067	22	0.8713	0.0099	-0.0427	0.0003	-0.0003	-0.0525	0.2209
-0.0757	-0.0066	24	0.8860	0.0109	-0.0544	0.0005	-0.0003	-0.0525	0.2277
-0.0757	-0.0064	26	0.9004	0.0116	-0.0690	0.0018	-0.0002	-0.0525	0.2453
M = 0.85									
-0.0710	-0.0120	-4	-0.4999	0.0356	0.0159	0.0268	0.0025	0.2756	-0.1279
-0.0710	-0.0119	-2	-0.3638	0.0429	0.0139	0.0249	0.0027	0.2772	-0.1197
-0.0708	-0.0115	0	-0.2294	0.0486	0.0135	0.0244	0.0033	0.2886	-0.0979
-0.0707	-0.0110	2	-0.1097	0.0489	0.0142	0.0253	0.0038	0.2967	-0.0635
-0.0706	-0.0104	4	0.0189	0.0444	0.0160	0.0254	0.0044	0.3049	-0.0227
-0.0708	-0.0097	6	0.1599	0.0341	0.0173	0.0285	0.0047	0.2902	0.0200
-0.0712	-0.0092	8	0.3176	0.0266	0.0083	0.0266	0.0041	0.2641	0.0526
-0.0721	-0.0086	10	0.5027	0.0169	-0.0168	0.0118	-0.0002	0.2005	0.0880
-0.0723	-0.0077	12	0.5966	0.0225	-0.0030	0.0106	0.0014	0.1859	0.1424
-0.0732	-0.0073	14	0.7066	0.0175	-0.0085	0.0035	0.0007	0.1223	0.1687
-0.0749	-0.0071	16	0.7508	0.0121	-0.0235	0.0008	0.0002	0.0065	0.1850
-0.0753	-0.0068	18	0.8113	0.0101	-0.0344	-0.0003	-0.0001	-0.0196	0.2031
M = 0.90									
-0.0704	-0.0122	-4	-0.5491	0.0476	0.0559	0.0333	0.0034	0.2995	-0.1290
-0.0704	-0.0120	-2	-0.3958	0.0525	0.0438	0.0316	0.0028	0.3025	-0.1196
-0.0700	-0.0118	0	-0.2564	0.0559	0.0331	0.0305	0.0033	0.3240	-0.1051
-0.0700	-0.0116	2	-0.1167	0.0539	0.0240	0.0286	0.0034	0.3240	-0.0940
-0.0700	-0.0111	4	0.0243	0.0475	0.0223	0.0284	0.0043	0.3271	-0.0666
-0.0702	-0.0103	6	0.1650	0.0382	0.0218	0.0303	0.0044	0.3133	-0.0188
-0.0702	-0.0103	6	0.1650	0.0382	0.0218	0.0303	0.0044	0.3133	-0.0188
-0.0706	-0.0092	8	0.3344	0.0291	0.0128	0.0299	0.0035	0.2903	0.0478
-0.0706	-0.0084	10	0.5176	0.0267	-0.0093	0.0144	0.0027	0.2857	0.0940
-0.0712	-0.0075	12	0.6485	0.0260	-0.0210	0.0084	0.0017	0.2457	0.1469
-0.0731	-0.0071	14	0.7307	0.0187	-0.0171	0.0013	0.0008	0.1259	0.1751
M = 0.93									
-0.0695	-0.0118	-4	-0.5308	0.0523	0.0626	0.0323	0.0037	0.3467	-0.1043
-0.0695	-0.0116	-2	-0.3880	0.0571	0.0496	0.0324	0.0031	0.3452	-0.0919
-0.0694	-0.0114	0	-0.2417	0.0620	0.0405	0.0317	0.0035	0.3571	-0.0794
-0.0693	-0.0112	2	-0.1171	0.0595	0.0350	0.0318	0.0039	0.3601	-0.0712
-0.0693	-0.0111	4	0.0242	0.0523	0.0276	0.0318	0.0044	0.3601	-0.0645
-0.0695	-0.0106	6	0.1822	0.0421	0.0197	0.0328	0.0040	0.3452	-0.0331
-0.0698	-0.0091	8	0.3646	0.0347	0.0048	0.0303	0.0038	0.3273	0.0530
-0.0698	-0.0077	10	0.5564	0.0317	-0.0204	0.0150	0.0026	0.3273	0.1299

TABLE VII.- AERODYNAMIC CHARACTERISTICS - Continued

(d) $\delta_s = -0.075$; $\frac{\delta_d}{\delta_s} = 0.27$

$\delta_{s,corr}$	$\delta_{d,corr}$	α , deg	C_N	C_A	C_m	ΔC_l	ΔC_n	$C_{h,s}$	$C_{h,d}$
M = 0.60									
-.0728	-.0206	-4	-.3941	.0342	.0015	.0203	.0033	.2420	-.0579
-.0727	-.0205	-2	-.2748	.0421	.0033	.0198	.0032	.2576	-.0478
-.0725	-.0203	0	-.1603	.0477	.0051	.0202	.0040	.2810	-.0318
-.0724	-.0201	2	-.0505	.0487	.0080	.0208	.0042	.2862	-.0087
-.0723	-.0199	4	.0591	.0448	.0106	.0224	.0048	.2967	.0101
-.0726	-.0197	6	.1793	.0355	.0117	.0234	.0042	.2706	.0261
-.0728	-.0196	8	.2701	.0277	.0048	.0215	.0036	.2446	.0449
-.0729	-.0194	10	.4793	.0184	-.0043	.0142	.0027	.2342	.0593
-.0732	-.0192	12	.6244	.0125	-.0098	.0088	.0023	.2004	.0811
-.0737	-.0188	14	.6897	.0086	.0128	.0065	.0009	.1457	.1245
-.0739	-.0183	16	.7481	.0131	.0048	.0050	.0007	.1171	.1693
-.0746	-.0181	18	.8003	.0111	-.0088	.0022	.0002	.0468	.1911
-.0748	-.0179	20	.5776	.0118	-.0133	.0046	.0000	.0182	.2084
-.0749	-.0178	22	.8586	.0124	-.0193	-.0012	.0000	.0130	.2186
-.0749	-.0178	24	.8474	.0152	-.0311	-.0004	.0002	.0156	.2186
-.0748	-.0178	26	.8504	.0162	-.0424	.0002	.0002	.0208	.2171
M = 0.80									
-.0710	-.0218	-4	-.4581	.0365	.0090	.0233	.0031	.2982	-.1200
-.0709	-.0215	-2	-.3299	.0457	.0114	.0233	.0035	.3069	-.1024
-.0707	-.0212	0	-.2009	.0510	.0122	.0231	.0042	.3227	-.0810
-.0706	-.0208	2	-.0852	.0513	.0139	.0240	.0046	.3262	-.0576
-.0706	-.0206	4	.0407	.0466	.0160	.0252	.0050	.3315	-.0420
-.0707	-.0203	6	.1698	.0375	.0159	.0265	.0050	.3192	-.0215
-.0711	-.0200	8	.3293	.0287	.0036	.0233	.0039	.2877	.0029
-.0718	-.0196	10	.4933	.0203	-.0102	.0119	.0020	.2385	.0263
-.0721	-.0188	12	.5782	.0236	.0057	.0110	.0016	.2192	.0839
-.0730	-.0181	14	.6778	.0176	.0042	.0067	.0009	.1508	.1288
-.0742	-.0177	16	.7414	.0135	-.0114	.0034	.0004	.0631	.1580
-.0745	-.0172	18	.8070	.0121	-.0208	.0007	.0001	.0351	.1873
-.0747	-.0170	20	.8489	.0111	-.0282	.0007	.0000	.0193	.2068
-.0748	-.0168	22	.8697	.0117	-.0385	-.0004	-.0001	.0175	.2166
-.0748	-.0167	24	.8854	.0128	-.0502	.0009	-.0001	.0158	.2244
-.0748	-.0165	26	.9162	.0134	-.0663	.0007	.0000	.0175	.2351
M = 0.85									
-.0703	-.0222	-4	-.4888	.0408	.0184	.0259	.0030	.3254	-.1364
-.0703	-.0221	-2	-.3515	.0491	.0179	.0250	.0033	.3286	-.1346
-.0701	-.0220	0	-.2166	.0546	.0183	.0245	.0039	.3417	-.1255
-.0700	-.0216	2	-.0971	.0538	.0182	.0248	.0043	.3450	-.1037
-.0700	-.0212	4	.0257	.0489	.0189	.0254	.0049	.3450	-.0791
-.0702	-.0207	6	.1606	.0390	.0191	.0287	.0053	.3352	-.0437
-.0706	-.0203	8	.3224	.0307	.0090	.0273	.0044	.3090	-.0164
-.0711	-.0196	10	.5030	.0219	-.0097	.0139	.0012	.2698	.0273
-.0716	-.0187	12	.5932	.0250	.0010	.0121	.0017	.2371	.0828
-.0725	-.0180	14	.6917	.0194	-.0017	.0065	.0007	.1733	.1255
-.0740	-.0174	16	.7673	.0138	-.0195	.0021	.0003	.0687	.1619
-.0745	-.0171	18	.8264	.0122	-.0330	-.0007	-.0004	.0360	.1855
M = 0.90									
-.0695	-.0228	-4	-.5252	.0505	.0454	.0307	.0035	.3615	-.1677
-.0695	-.0228	-2	-.3910	.0582	.0397	.0311	.0033	.3615	-.1694
-.0694	-.0226	0	-.2515	.0624	.0329	.0295	.0039	.3677	-.1549
-.0692	-.0223	2	-.1185	.0608	.0315	.0298	.0041	.3800	-.1395
-.0693	-.022	4	.0130	.0541	.0265	.0293	.0049	.3754	-.1172
-.0694	-.0215	6	.1543	.0438	.0255	.0317	.0050	.3631	-.0916
-.0698	-.0208	8	.3317	.0345	.0114	.0297	.0041	.3415	-.0488
-.0698	-.0200	10	.5008	.0307	-.0094	.0153	.0031	.3384	.0000
-.0707	-.0189	12	.6191	.0263	-.0030	.0111	.0018	.2784	.0642
-.0724	-.0179	14	.7066	.0201	-.0120	.0038	.0009	.1723	.1224
M = 0.93									
-.0688	-.0229	-4	-.5346	.0618	.0636	.0324	.0043	.3949	-.1658
-.0687	-.0228	-2	-.4002	.0665	.0513	.0327	.0041	.3979	-.1625
-.0686	-.0227	0	-.2646	.0684	.0433	.0332	.0042	.4054	-.1575
-.0686	-.0225	2	-.1336	.0644	.0404	.0333	.0044	.4039	-.1426
-.0686	-.0221	4	.0025	.0588	.0343	.0341	.0051	.4069	-.1235
-.0688	-.0217	6	.1579	.0470	.0271	.0350	.0046	.3905	-.0970
-.0690	-.0211	8	.3346	.0396	.0109	.0326	.0043	.3800	-.0630
-.0691	-.0201	10	.5122	.0360	-.0167	.0180	.0030	.3726	-.0075

TABLE VII.- AERODYNAMIC CHARACTERISTICS - Continued

(e) $\delta_s = -0.075$; $\frac{\delta_d}{\delta_s} = 0.87$

δ_s, corr	δ_d, corr	α, deg	C_N	C_A	C_m	ΔC_l	ΔC_n	$C_{h,s}$	$C_{h,d}$
M = 0.60									
-.0726	-.0512	-4	-.4745	.0539	.0064	.0216	.0051	.2569	-.1672
-.0725	-.0513	-2	-.3661	.0622	.0086	.0224	.0051	.2723	-.1715
-.0724	-.0513	0	-.2572	.0679	.0117	.0242	.0058	.2826	-.1715
-.0723	-.0512	2	-.1560	.0139	.0182	.0280	.0055	.2929	-.1601
-.0723	-.0511	4	-.0440	.0645	.0220	.0285	.0066	.2980	-.1529
-.0722	-.0510	6	.0696	.0543	.0231	.0298	.0060	.3006	-.1386
-.0725	-.0510	8	.2152	.0426	.0164	.0274	.0053	.2698	-.1315
-.0729	-.0509	10	.3560	.0353	.0057	.0218	.0042	.2312	-.1243
-.0733	-.0508	12	.4973	.0278	-.0030	.0142	.0036	.1824	-.1115
-.0738	-.0506	14	.5536	.0263	.0241	.0145	.0022	.1285	-.0872
-.0740	-.0503	16	.6201	.0236	.0107	.0115	.0015	.1105	-.0386
-.0745	-.0500	18	.6955	.0183	-.0010	.0062	.0009	.0591	-.0029
-.0748	-.0499	20	.7622	.0146	-.0130	.0011	.0006	.0206	.0186
-.0749	-.0498	22	.7765	.0173	-.0178	.0005	.0005	.0103	.0243
-.0748	-.0498	24	.7659	.0206	-.0260	.0016	.0007	.0180	.0257
-.0749	-.0498	26	.7838	.0215	-.0372	.0017	.0007	.0128	.0329
M = 0.80									
-.0708	-.0520	-4	-.4908	.0576	.0117	.0218	.0055	.3118	-.1821
-.0707	-.0522	-2	-.3670	.0654	.0146	.0230	.0055	.3170	-.1946
-.0706	-.0522	0	-.2556	.0719	.0186	.0244	.0062	.3205	-.1995
-.0706	-.0522	2	-.1438	.0722	.0241	.0265	.0066	.3257	-.1985
-.0706	-.0521	4	-.0420	.0674	.0280	.0299	.0070	.3274	-.1927
-.0706	-.0520	6	.0827	.0581	.0318	.0320	.0069	.3240	-.1850
-.0712	-.0519	8	.2380	.0494	.0208	.0304	.0059	.2789	-.1744
-.0720	-.0518	10	.3965	.0393	.0047	.0195	.0037	.2235	-.1590
-.0724	-.0515	12	.4673	.0405	.0207	.0196	.0032	.1906	-.1320
-.0731	-.0511	14	.5678	.0327	.0161	.0139	.0023	.1386	-.0983
-.0742	-.0508	16	.6670	.0259	.0008	.0084	.0015	.0606	-.0742
-.0745	-.0507	18	.7209	.0227	-.0105	.0054	.0010	.0346	-.0644
-.0749	-.0506	20	.7720	.0213	-.0201	.0048	.0009	.0087	-.0549
-.0751	-.0505	22	.8197	.0218	-.0294	.0028	.0008	-.0052	-.0453
-.0751	-.0503	24	.8188	.0215	-.0383	.0053	.0007	-.0052	-.0299
-.0751	-.0501	26	.8429	.0203	-.0525	.0057	.0006	-.0069	-.0077
M = 0.85									
-.0701	-.0525	-4	-.4947	.0591	.0127	.0224	.0050	.3358	-.2083
-.0701	-.0526	-2	-.3705	.0689	.0182	.0232	.0053	.3374	-.2173
-.0700	-.0526	0	-.2522	.0751	.0219	.0242	.0059	.3422	-.2218
-.0700	-.0526	2	-.1424	.0751	.0265	.0263	.0064	.3438	-.2173
-.0700	-.0525	4	-.0264	.0694	.0307	.0284	.0068	.3422	-.2083
-.0702	-.0524	6	.0954	.0604	.0337	.0336	.0072	.3261	-.1993
-.0708	-.0523	8	.2577	.0514	.0230	.0278	.0065	.2906	-.1939
-.0713	-.0521	10	.3713	.0511	.0214	.0294	.0040	.2518	-.1760
-.0722	-.0518	12	.4810	.0425	.0205	.0220	.0034	.1937	-.1490
-.0729	-.0514	14	.5867	.0358	.0135	.0153	.0024	.1453	-.1140
-.0740	-.0511	16	.6818	.0298	-.0014	.0079	.0019	.0678	-.0934
-.0746	-.0509	18	.7377	.0258	-.0159	.0061	.0014	.0291	-.0790
M = 0.90									
-.0694	-.0527	-4	-.4886	.0665	.0243	.0242	.0051	.3640	-.2127
-.0694	-.0529	-2	-.3520	.0733	.0218	.0247	.0050	.3610	-.2289
-.0694	-.0529	0	-.2231	.0778	.0235	.0255	.0056	.3656	-.2306
-.0694	-.0528	2	-.1108	.0754	.0274	.0273	.0057	.3640	-.2255
-.0694	-.0527	4	.0018	.0711	.0328	.0303	.0066	.3656	-.2170
-.0696	-.0526	6	.1286	.0609	.0369	.0343	.0068	.3503	-.2084
-.0698	-.0525	8	.2772	.0547	.0306	.0354	.0063	.3350	-.2016
-.0700	-.0525	10	.4512	.0527	.0086	.0209	.0055	.3273	-.1965
-.0711	-.0522	12	.5554	.0459	.0201	.0188	.0040	.2554	-.1753
-.0726	-.0517	14	.6421	.0391	.0087	.0114	.0030	.1545	-.1395
M = 0.93									
-.0691	-.0529	-4	-.4809	.0698	.0283	.0244	.0049	.3707	-.2227
-.0694	-.0531	-2	-.3567	.0759	.0254	.0269	.0046	.3529	-.2367
-.0691	-.0532	0	-.2237	.0825	.0270	.0281	.0056	.3707	-.2474
-.0691	-.0532	2	-.1119	.0825	.0325	.0304	.0063	.3722	-.2441
-.0691	-.0530	4	.0024	.0751	.0353	.0338	.0066	.3707	-.2318
-.0693	-.0529	6	.1360	.0642	.0389	.0375	.0063	.3589	-.2227
-.0695	-.0528	8	.2881	.0600	.0307	.0383	.0068	.3485	-.2202
-.0696	-.0527	10	.4602	.0571	.0082	.0251	.0054	.3396	-.2120

TABLE VII.- AERODYNAMIC CHARACTERISTICS - Concluded

(f) $\delta_s = -0.075$; $\frac{\delta_d}{\delta_s} = 1.00$

$\delta_{s,corr}$	$\delta_{d,corr}$	α , deg	C_N	C_A	C_m	ΔC_l	ΔC_n	$C_{h,s}$	$C_{h,d}$
M = 0.80									
-.0729	-.0763	-4	-.4020	.0694	.0046	.0178	.0067	.2374	-.2147
-.0728	-.0764	-2	-.3056	.0770	.0126	.0204	.0066	.2452	-.2234
-.0727	-.0764	0	-.2047	.0833	.0175	.0228	.0075	.2530	-.2249
-.0727	-.0764	2	-.1083	.0850	.0235	.0257	.0078	.2556	-.2278
-.0726	-.0764	4	-.0070	.0817	.0288	.0295	.0083	.2608	-.2307
-.0726	-.0764	6	.0936	.0731	.0326	.0315	.0078	.2634	-.2292
-.0729	-.0764	8	.2321	.0645	.0261	.0303	.0072	.2374	-.2263
-.0731	-.0764	10	.3705	.0549	.0171	.0252	.0062	.2087	-.2176
-.0734	-.0763	12	.5144	.0484	.0039	.0183	.0057	.1748	-.2060
-.0738	-.0762	14	.5329	.0487	.0339	.0223	.0046	.1278	-.1872
-.0741	-.0760	16	.6151	.0454	.0251	.0177	.0038	.1017	-.1668
-.0745	-.0760	18	.7016	.0394	.0108	.0118	.0030	.0522	-.1523
-.0750	-.0759	20	.7641	.0357	.0016	.0064	.0027	.0052	-.1480
-.0752	-.0759	22	.7833	.0362	-.0032	.0051	.0025	-.0183	-.1509
-.0752	-.0760	24	.7913	.0399	-.0150	.0038	.0025	-.0209	-.1567
-.0752	-.0760	26	.8001	.0398	-.0264	.0051	.0025	-.0261	-.1523
M = 0.80									
-.0715	-.0770	-4	-.4004	.0708	-.0002	.0139	.0071	.2620	-.2211
-.0714	-.0771	-2	-.3053	.0788	.0137	.0197	.0070	.2673	-.2309
-.0714	-.0772	0	-.1953	.0835	.0193	.0214	.0076	.2708	-.2348
-.0713	-.0772	2	-.0947	.0844	.0252	.0247	.0080	.2761	-.2348
-.0713	-.0771	4	.0024	.0799	.0313	.0288	.0083	.2796	-.2309
-.0714	-.0772	6	.1155	.0727	.0354	.0314	.0084	.2726	-.2358
-.0718	-.0772	8	.2603	.0655	.0266	.0308	.0076	.2409	-.2387
-.0724	-.0772	10	.4050	.0575	.0125	.0212	.0056	.1970	-.2348
-.0729	-.0771	12	.4521	.0618	.0373	.0251	.0054	.1600	-.2269
-.0735	-.0770	14	.5446	.0572	.0358	.0203	.0050	.1126	-.2201
-.0743	-.0769	16	.6351	.0504	.0212	.0151	.0042	.0510	-.2054
-.0747	-.0768	18	.7006	.0463	.0085	.0123	.0037	.0229	-.1956
-.0751	-.0767	20	.7515	.0450	-.0015	.0104	.0033	-.0053	-.1888
-.0754	-.0767	22	.7936	.0429	-.0097	.0091	.0030	-.0317	-.1819
-.0755	-.0766	24	.7843	.0411	-.0199	.0098	.0027	-.0405	-.1712
-.0756	-.0765	26	.8327	.0391	-.0360	.0096	.0025	-.0440	-.1595
M = 0.85									
-.0711	-.0773	-4	-.3999	.0722	-.0024	.0130	.0067	.2688	-.2333
-.0711	-.0774	-2	-.3022	.0820	.0146	.0182	.0069	.2720	-.2443
-.0711	-.0775	0	-.1967	.0874	.0204	.0210	.0074	.2737	-.2488
-.0710	-.0775	2	-.0973	.0868	.0265	.0242	.0077	.2753	-.2479
-.0710	-.0774	4	.0085	.0819	.0333	.0274	.0082	.2802	-.2461
-.0711	-.0775	6	.1353	.0744	.0374	.0320	.0088	.2704	-.2488
-.0714	-.0775	8	.2666	.0692	.0272	.0331	.0086	.2507	-.2552
-.0722	-.0775	10	.4117	.0650	.0195	.0273	.0052	.1966	-.2507
-.0728	-.0775	12	.4762	.0654	.0359	.0255	.0058	.1540	-.2507
-.0735	-.0774	14	.5531	.0598	.0345	.0213	.0051	.1065	-.2406
-.0743	-.0772	16	.6314	.0535	.0217	.0154	.0044	.0492	-.2260
-.0748	-.0771	18	.6973	.0497	.0064	.0127	.0039	.0131	-.2133
M = 0.90									
-.0710	-.0777	-4	-.4194	.0613	.0043	.0172	.0063	.2637	-.2522
-.0710	-.0777	-2	-.3067	.0862	.0157	.0199	.0065	.2652	-.2599
-.0709	-.0778	0	-.1962	.0925	.0229	.0230	.0072	.2683	-.2659
-.0708	-.0778	2	-.0987	.0915	.0032	.0261	.0075	.2729	-.2667
-.0707	-.0778	4	.0141	.0859	.0367	.0299	.0083	.2791	-.2633
-.0709	-.0778	6	.1303	.0780	.0409	.0347	.0086	.2714	-.2633
-.0711	-.0779	8	.2740	.0736	.0323	.0359	.0085	.2544	-.2753
-.0712	-.0779	10	.4292	.0708	.0103	.0230	.0075	.2467	-.2753
M = 0.93									
-.0707	-.0780	-4	-.4307	.0850	.0133	.0183	.0072	.2719	-.2742
-.0707	-.0781	-2	-.3073	.0941	.0209	.0216	.0073	.2704	-.2867
-.0706	-.0782	0	-.1949	.1004	.0277	.0251	.0082	.2764	-.2908
-.0706	-.0781	2	-.0932	.0980	.0342	.0286	.0081	.2794	-.2890
-.0705	-.0781	4	.0067	.0925	.0437	.0350	.0060	.2868	-.2817
-.0706	-.0780	6	.1379	.0811	.0462	.0380	.0084	.2764	-.2742
-.0707	-.0781	8	.2804	.0806	.0373	.0402	.0090	.2734	-.2883
-.0710	-.0782	10	.4434	.0752	.0086	.0256	.0073	.2569	-.2917

TABLE VIII.- AERODYNAMIC CHARACTERISTICS

(a) $\delta_s = -0.100$; $\frac{\delta_d}{\delta_s} = 0$

$\delta_{s,corr}$	$\delta_{d,corr}$	α , deg	C_N	C_A	C_m	ΔC_l	ΔC_n	$C_{h,s}$	$C_{h,d}$
M = 0.80									
-.0974	.0002	-4	-.4290	.0490	-.0025	.0219	.0043	.3580	.0215
-.0974	.0002	-2	-.3255	.0509	-.0010	.0231	.0041	.3580	.0229
-.0974	.0003	0	-.2114	.0570	.0012	.0244	.0049	.3580	.0272
-.0974	.0004	2	-.1026	.0596	.0040	.0256	.0056	.3657	.0430
-.0973	.0004	4	.0161	.0583	.0044	.0268	.0065	.3708	.0430
-.0973	.0005	6	.1294	.0513	.0050	.0283	.0060	.3734	.0501
-.0975	.0006	8	.2664	.0409	.0031	.0265	.0051	.3477	.0587
-.0979	.0007	10	.4604	.0310	-.0125	.0163	.0039	.2910	.0716
-.0980	.0009	12	.5973	.0280	-.0028	.0144	.0043	.2704	.0902
-.0989	.0010	14	.6720	.0187	.0026	.0061	.0012	.1494	.0974
-.0996	.0011	16	.7686	.0085	-.0025	-.0002	.0001	.0489	.1103
-.1003	.0011	18	.8056	.0039	-.0124	-.0015	-.0006	-.0361	.1117
-.1005	.0012	20	.8542	.0026	-.0168	-.0028	-.0008	-.0695	.1175
-.1005	.0012	22	.8489	.0048	-.0224	-.0027	-.0009	-.0721	.1189
-.1005	.0012	24	.9471	.0080	-.0345	-.0017	-.0007	-.0721	.1203
-.1005	.0012	26	.8352	.0096	-.0469	-.0025	-.0007	-.0721	.1232
M = 0.80									
-.0957	.0003	-4	-.4971	.0438	.0048	.0269	.0037	.4022	.0193
-.0958	.0004	-2	-.3702	.0529	.0072	.0283	.0042	.3900	.0270
-.0958	.0005	0	-.2530	.0596	.0085	.0286	.0051	.3918	.0357
-.0957	.0007	2	-.1417	.0621	.0104	.0297	.0059	.3970	.0472
-.0956	.0009	4	-.0080	.0609	.0095	.0301	.0068	.4091	.0627
-.0957	.0010	6	.1131	.0531	.0112	.0318	.0069	.3970	.0694
-.0961	.0012	8	.2850	.0437	.0020	.0281	.0054	.3606	.0781
-.0969	.0013	10	.4778	.0323	-.0191	.0122	.0060	.2860	.0868
-.0977	.0014	12	.5942	.0274	-.0150	.0063	.0016	.2132	.0964
-.0988	.0016	14	.6788	.0173	-.0017	.0054	.0007	.1109	.1070
-.0999	.0016	16	.7582	.0078	-.0161	.0004	-.0002	.0052	.1070
-.1003	.0017	18	.8057	.0065	-.0248	-.0022	-.0005	-.0312	.1109
-.1005	.0017	20	.8545	.0044	-.0307	-.0022	-.0007	-.0468	.1138
-.1006	.0017	22	.8698	.0055	-.0394	-.0001	-.0006	-.0520	.1157
-.1004	.0018	24	.8939	.0079	-.0524	-.0011	-.0003	-.0381	.1186
-.1005	.0018	26	.8988	.0089	-.0669	.0006	-.0003	-.0485	.1186
M = 0.85									
-.0950	.0000	-4	-.5515	.0468	.0194	.0328	.0041	.4304	.0009
-.0952	.0003	-2	-.4075	.0546	.0147	.0310	.0044	.4174	.0162
-.0952	.0005	0	-.2807	.0613	.0151	.0312	.0054	.4191	.0324
-.0951	.0008	2	-.1498	.0645	.0154	.0317	.0064	.4255	.0504
-.0950	.0011	4	-.0133	.0626	.0127	.0329	.0073	.4336	.0711
-.0952	.0012	6	.1115	.0545	.0130	.0364	.0074	.4191	.0783
-.0957	.0014	8	.2927	.0460	.0009	.0311	.0075	.3738	.0864
-.0960	.0015	10	.4912	.0417	-.0223	.0151	.0050	.3430	.0936
-.0973	.0016	12	.6054	.0296	-.0188	.0074	.0019	.2362	.0990
-.0985	.0018	14	.6938	.0192	-.0058	.0072	.0008	.1278	.1098
-.0999	.0018	16	.7824	.0102	-.0233	-.0003	.0000	.0129	.1098
M = 0.90									
-.0945	-.0001	-4	-.5978	.0556	.0623	.0365	.0055	.4473	-.0034
-.0948	.0001	-2	-.4470	.0619	.0455	.0360	.0054	.4245	.0034
-.0947	.0005	0	-.3039	.0683	.0330	.0354	.0063	.4336	.0296
-.0946	.0009	2	-.1655	.0697	.0231	.0352	.0071	.4412	.0516
-.0944	.0013	4	-.0121	.0670	.0155	.0353	.0079	.4534	.0795
-.0947	.0015	6	.1133	.0584	.0148	.0401	.0078	.4321	.0880
-.0950	.0016	8	.2802	.0501	.0032	.0378	.0062	.4123	.0922
-.0949	.0017	10	.4506	.0536	-.0086	.0254	.0059	.4169	.0999
-.0949	.0018	12	.6361	.0359	-.0197	.0331	.0026	.4138	.1032
M = 0.93									
-.0939	.0020	-4	-.5613	.0670	.0476	.0310	.0070	.4807	.1140
-.0941	.0019	-2	-.4144	.0733	.0434	.0311	.0072	.4689	.1107
-.0941	.0019	0	-.2726	.0766	.0295	.0318	.0075	.4703	.1066
-.0938	.0018	2	-.1335	.0784	.0157	.0325	.0082	.4895	.1033
-.0937	.0018	4	.0091	.0743	.0047	.0330	.0087	.4998	.1009
-.0939	.0017	6	.1351	.0659	.0013	.0378	.0085	.4807	.0943
-.0942	.0017	8	.2831	.0604	-.0183	.0386	.0059	.4586	.0943
-.0938	.0018	10	.4753	.0621	-.0296	.0255	.0072	.4895	.1017

TABLE VIII.- AERODYNAMIC CHARACTERISTICS - Continued

(b) $\delta_S = -0.100$; $\frac{h_i}{\delta_S} = 0.05$

δ_S, corr	δ_d, corr	α, deg	C_N	C_A	C_m	ΔC_L	ΔC_N	$C_{h,s}$	$C_{h,d}$
M = 0.60									
-.0976	-.0048	-4	-.4131	.0484	-.0027	.0599	.0047	.3376	.0218
-.0977	-.0047	-2	-.3355	.0533	-.0015	.0249	.0044	.3298	.0291
-.0977	-.0045	0	-.2199	.0602	.0007	.0260	.0053	.3271	.0553
-.0977	-.0044	2	-.1094	.0622	.0023	.0266	.0058	.3219	.0568
-.0977	-.0043	4	.0012	.0610	.0040	.0287	.0066	.3298	.0713
-.0976	-.0042	6	.1216	.0544	.0051	.0291	.0062	.3350	.0830
-.0977	-.0041	8	.2413	.0439	.0048	.0294	.0052	.3193	.0946
-.0981	-.0038	10	.4475	.0327	-.0122	.0172	.0041	.2722	.1208
-.0984	-.0036	12	.6053	.0262	-.0111	.0128	.0041	.2277	.1412
-.0991	-.0034	14	.6583	.0197	-.0022	.0088	.0015	.1282	.1659
-.0997	-.0032	16	.7561	.0110	-.0039	.0033	.0002	.0366	.1834
-.1002	-.0031	18	.8118	.0052	-.0135	-.0056	-.0005	-.0236	.1878
-.1004	-.0031	20	.8287	.0062	-.0166	.0001	-.0006	-.0523	.1907
-.1005	-.0031	22	.8480	.0077	-.0241	-.0010	-.0007	-.0654	.1965
-.1004	-.0031	24	.8265	.0105	-.0341	.0000	-.0005	-.0628	.1965
-.1004	-.0030	26	.8449	.0126	-.0464	.0003	-.0004	-.0602	.2023
M = 0.80									
-.0963	-.0051	-4	-.5116	.0466	.0045	.0259	.0042	.3543	-.0049
-.0963	-.0050	-2	-.3834	.0557	.0061	.0297	.0045	.3455	.0020
-.0963	-.0047	0	-.2564	.0627	.0229	.0293	.0054	.3543	.0196
-.0962	-.0044	2	-.1441	.0661	.0099	.0308	.0062	.3632	.0412
-.0960	-.0041	4	-.0149	.0634	.0096	.0309	.0069	.3737	.0637
-.0961	-.0038	6	.1053	.0555	.0116	.0334	.0070	.3684	.0794
-.0964	-.0035	8	.2700	.0457	.0030	.0309	.0055	.3420	.1039
-.0973	-.0032	10	.4792	.0325	-.0205	.0138	.0031	.2591	.1206
-.0979	-.0029	12	.5909	.0273	-.0161	.0070	.0014	.1974	.1432
-.0989	-.0025	14	.6740	.0185	-.0029	.0068	.0007	.1022	.1677
-.0999	-.0024	16	.7545	.0110	-.0176	.0019	.0000	.0053	.1794
-.1003	-.0023	18	.8007	.0093	-.0250	.0010	-.0004	-.0247	.1863
-.1005	-.0021	20	.8524	.0076	-.0324	-.0003	-.0006	-.0494	.1961
-.1006	-.0021	22	.8849	.0082	-.0398	-.0004	-.0006	-.0564	.2010
-.1006	-.0020	24	.8900	.0107	-.0530	.0009	-.0004	-.0546	.2049
-.1006	-.0020	26	.9072	.0113	-.0663	.0010	-.0003	-.0582	.2069
M = 0.85									
-.0954	-.0067	-4	-.5483	.0529	.0167	.0331	.0041	.4075	-.1078
-.0954	-.0064	-2	-.4136	.0613	.0164	.0323	.0044	.4075	-.0905
-.0954	-.0061	0	-.2850	.0688	.0140	.0313	.0053	.4075	-.0676
-.0953	-.0052	2	-.1583	.0702	.0130	.0316	.0060	.4124	-.0128
-.0954	-.0042	4	-.0227	.0657	.0118	.0312	.0067	.4059	.0530
-.0955	-.0038	6	.1009	.0575	.0134	.0357	.0073	.3977	.0795
-.0959	-.0033	8	.2787	.0488	.0020	.0329	.0062	.3648	.1078
-.0965	-.0029	10	.4844	.0409	-.0195	.0168	.0028	.3089	.1344
-.0975	-.0027	12	.5996	.0309	-.0193	.0094	.0017	.2185	.1481
-.0986	-.0023	14	.6885	.0210	-.0069	.0064	.0007	.1216	.1737
-.0999	-.0022	16	.7548	.0113	-.0225	.0021	-.0002	.0115	.1755
-.1001	-.0021	18	.8033	.0100	-.0302	.0015	-.0003	-.0131	.1837
M = 0.90									
-.0946	-.0066	-4	-.6103	.0627	.0664	.0422	.0047	.4453	-.0955
-.0949	-.0063	-2	-.4626	.0691	.0489	.0403	.0043	.4237	-.0808
-.0949	-.0060	0	-.3086	.0756	.0354	.0372	.0052	.4237	-.0602
-.0949	-.0058	2	-.1735	.0761	.0236	.0361	.0056	.4267	-.0456
-.0949	-.0045	4	-.0268	.0701	.0146	.0346	.0070	.4252	.0292
-.0950	-.0035	6	.1033	.0608	.0150	.0374	.0070	.4128	.0912
-.0953	-.0031	8	.2795	.0517	.0023	.0366	.0056	.3865	.1144
-.0961	-.0027	10	.4829	.0398	-.0235	.0179	.0031	.3201	.1385
-.0970	-.0022	12	.6162	.0358	-.0210	.0125	.0024	.2505	.1660
-.0981	-.0021	14	.7322	.0256	-.0222	.0009	.0012	.1608	.1763
M = 0.93									
-.0939	-.0056	-4	-.5542	.0743	.0648	.0378	.0061	.4913	-.0325
-.0942	-.0054	-2	-.4193	.0626	.0484	.0380	.0051	.4674	-.0242
-.0943	-.0051	0	-.2852	.0823	.0326	.0363	.0057	.4599	-.0033
-.0942	-.0046	2	-.1490	.0827	.0199	.0353	.0065	.4674	.0258
-.0941	-.0037	4	-.0046	.0754	.0051	.0349	.0070	.4704	.0775
-.0944	-.0030	6	.1382	.0669	.0029	.0375	.0069	.4524	.1175
-.0944	-.0026	8	.2902	.0627	-.0045	.0397	.0073	.4494	.1400
-.0951	-.0022	10	.4832	.0538	-.0269	.0242	.0045	.3925	.1633

TABLE VIII.- AERODYNAMIC CHARACTERISTICS - Continued

(c) $\delta_s = -0.100$; $\frac{\delta_d}{\delta_s} = 0.10$

$\delta_{s,corr}$	$\delta_{d,corr}$	α , deg	C_N	C_A	C_m	ΔC_l	ΔC_n	$C_{h,s}$	$C_{h,d}$
M = 0.60									
-.0977	-.0101	-4	-.4448	.0486	-.0034	.0259	.0049	.3245	-.0073
-.0977	-.0103	-2	-.3300	.0550	-.0024	.0254	.0045	.3219	-.0029
-.0977	-.0099	0	-.2192	.0618	-.0002	.0269	.0055	.3219	.0116
-.0977	-.0097	2	-.1139	.0643	.0013	.0276	.0061	.3245	.0277
-.0976	-.0096	4	-.0082	.0621	.0031	.0301	.0067	.3324	.0422
-.0977	-.0094	6	.1128	.0555	.0046	.0312	.0063	.3298	.0568
-.0978	-.0093	8	.2426	.0444	.0044	.0312	.0053	.3114	.0742
-.0981	-.0090	10	.4339	.0333	-.0105	.0199	.0042	.2643	.1019
-.0984	-.0087	12	.6000	.0273	-.0159	.0132	.0042	.2225	.1281
-.0991	-.0084	14	.6599	.0219	.0026	.0108	.0018	.1256	.1601
-.0998	-.0082	16	.7417	.0132	-.0044	.0051	.0005	.0236	.1805
-.1003	-.0081	18	.7956	.0085	-.0127	.0036	-.0002	-.0445	.1892
-.1005	-.0080	20	.8346	.0072	-.0162	.0009	-.0003	-.0707	.1980
-.1015	-.0080	22	.8491	.0094	-.0228	.0003	-.0005	-.2068	.2009
-.1005	-.0082	24	.8272	.0122	-.0342	.0009	-.0003	-.0707	.1994
-.1005	-.0080	26	.8408	.0137	-.0460	.0016	-.0002	-.0707	.2023
M = 0.80									
-.0959	-.0111	-4	-.5080	.0489	.0050	.0305	.0044	.3843	-.0784
-.0960	-.0112	-2	-.3855	.0590	.0071	.0315	.0048	.3773	-.0814
-.0960	-.0108	0	-.2627	.0662	.0082	.0314	.0058	.3737	-.0579
-.0959	-.0103	2	-.1434	.0683	.0095	.0317	.0065	.3843	-.0216
-.0960	-.0098	4	-.0202	.0650	.0096	.0333	.0071	.3790	.0108
-.0960	-.0094	6	.0991	.0566	.0107	.0346	.0071	.3755	.0431
-.0964	-.0089	8	.2605	.0465	.0041	.0322	.0057	.3385	.0755
-.0972	-.0085	10	.4639	.0334	-.0173	.0166	.0033	.2609	.1020
-.0979	-.0081	12	.5724	.0292	-.0135	.0103	.0017	.1992	.1324
-.0990	-.0076	14	.6725	.0197	.0127	.0080	.0008	.0970	.1628
-.1001	-.0074	16	.7489	.0114	-.0179	.0039	.0001	-.0123	.1745
-.1004	-.0073	18	.7956	.0094	-.0238	.0035	-.0004	-.0405	.1873
-.1006	-.0070	20	.8439	.0080	-.0303	.0022	-.0006	-.0564	.2049
-.1007	-.0069	22	.8694	.0083	-.0386	.0022	-.0005	-.0617	.2138
-.1006	-.0067	24	.9003	.0107	-.0548	.0007	-.0003	-.0599	.2275
-.1007	-.0066	26	.8986	.0110	-.0665	.0035	-.0003	-.0635	.2314
M = 0.85									
-.0952	-.0121	-4	-.5534	.0550	.0193	.0348	.0044	.4190	-.1353
-.0954	-.0120	-2	-.4091	.0640	.0160	.0337	.0048	.4059	-.1280
-.0953	-.0118	0	-.2837	.0715	.0142	.0328	.0056	.4108	-.1170
-.0952	-.0113	2	-.1572	.0733	.0140	.0329	.0064	.4207	-.0841
-.0953	-.0105	4	-.0277	.0678	.0123	.0332	.0070	.4157	-.0320
-.0955	-.0096	6	.0959	.0585	.0123	.0379	.0075	.3993	.0256
-.0957	-.0088	8	.2737	.0479	.0029	.0348	.0061	.3582	.0768
-.0965	-.0081	10	.4703	.0403	-.0184	.0197	.0028	.3073	.1179
-.0975	-.0078	12	.6042	.0319	-.0175	.0110	.0020	.2185	.1417
-.0986	-.0073	14	.6988	.0212	-.0100	.0073	.0009	.1200	.1709
-.1000	-.0072	16	.7656	.0116	-.0237	.0034	.0000	-.0016	.1782
-.1003	-.0069	18	.8192	.0096	-.0347	.0012	-.0002	-.0279	.1965
M = 0.90									
-.0945	-.0122	-4	-.6030	.0661	.0633	.0439	.0052	.4546	-.1333
-.0947	-.0120	-2	-.4613	.0736	.0498	.0421	.0048	.4391	-.1204
-.0947	-.0119	0	-.3123	.0786	.0376	.0401	.0056	.4376	-.1144
-.0946	-.0117	2	-.1797	.0797	.0297	.0396	.0063	.4468	-.0989
-.0947	-.0113	4	-.0331	.0722	.0182	.0382	.0070	.4422	-.0765
-.0949	-.0101	6	.1026	.0618	.0152	.0405	.0072	.4206	-.0060
-.0952	-.0087	8	.2723	.0521	.0033	.0392	.0057	.3943	.0800
-.0963	-.0080	10	.4457	.0403	-.0211	.0216	.0032	.3108	.1204
-.0970	-.0073	12	.6177	.0361	-.0213	.0145	.0026	.2520	.1617
M = 0.93									
-.0941	-.0114	-4	-.5696	.0808	.0642	.0374	.0066	.4733	-.0833
-.0941	-.0112	-2	-.4202	.0855	.0487	.0369	.0061	.4718	-.0692
-.0940	-.0109	0	-.2848	.0904	.0358	.0367	.0066	.4838	-.0500
-.0939	-.0108	2	-.1622	.0894	.0282	.0370	.0073	.4943	-.0442
-.0939	-.0106	4	-.0259	.0821	.0172	.0373	.0079	.4913	-.0375
-.0941	-.0103	6	.1187	.0703	.0063	.0390	.0075	.4763	-.0158
-.0943	-.0081	8	.2897	.0630	-.0073	.0392	.0074	.4584	.1116
-.0942	-.0070	10	.4559	.0603	-.0199	.0269	.0061	.4644	.1725

TABLE VIII.- AERODYNAMIC CHARACTERISTICS - Continued

(d) $\delta_s = -0.100$; $\frac{\delta_d}{\delta_s} = 0.20$

δ_s, corr	δ_d, corr	α, deg	C_N	C_A	C_m	ΔC_l	ΔC_n	$C_{h,s}$	$C_{h,d}$
M = 0.60									
-.0974	-.0208	-4	-.4550	.0519	-.0022	.0258	.0051	.3610	-.0771
-.0974	-.0207	-2	-.3347	.0593	-.0017	.0259	.0049	.3663	-.0728
-.0973	-.0206	0	-.2194	.0661	.0001	.0266	.0058	.3794	-.0597
-.0972	-.0204	2	-.1190	.0692	.0016	.0277	.0064	.3872	-.0437
-.0972	-.0202	4	-.0084	.0670	.0043	.0298	.0071	.3872	-.0233
-.0973	-.0200	6	.1020	.0583	.0045	.0309	.0065	.3846	-.0015
-.0975	-.0198	8	.2270	.0478	.0065	.0312	.0055	.3558	.0204
-.0978	-.0195	10	.4089	.0362	-.0070	.0212	.0043	.3061	.0553
-.0982	-.0191	12	.5798	.0285	-.0141	.0143	.0040	.2564	.0873
-.0988	-.0188	14	.6590	.0192	-.0114	.0092	.0015	.1622	.1266
-.0994	-.0185	16	.7319	.0133	-.0017	.0061	.0003	.0785	.1513
-.1001	-.0184	18	.7791	.0075	-.0126	.0029	-.0003	-.0157	.1615
-.1003	-.0182	20	.8387	.0077	-.0158	-.0002	-.0003	-.0392	.1863
-.1002	-.0181	22	.8435	.0104	-.0202	-.0001	-.0003	-.0340	.1964
-.1002	-.0181	24	.8323	.0127	-.0311	.0008	-.0001	-.0288	.1964
-.1002	-.0181	26	.8304	.0142	-.0421	.0018	-.0001	-.0288	.1950
M = 0.80									
-.0956	-.0220	-4	-.5144	.0545	.0069	.0309	.0049	.4124	-.1372
-.0957	-.0219	-2	-.3857	.0652	.0084	.0310	.0054	.4106	-.1274
-.0956	-.0215	0	-.2663	.0728	.0109	.0310	.0064	.4141	-.1049
-.0955	-.0212	2	-.1499	.0749	.0122	.0320	.0071	.4265	-.0823
-.0955	-.0209	4	-.0302	.0712	.0123	.0337	.0076	.4265	-.0598
-.0956	-.0206	6	.0890	.0618	.0126	.0351	.0076	.4194	-.0392
-.0960	-.0201	8	.2508	.0506	.0055	.0333	.0060	.3771	-.0059
-.0963	-.0194	10	.4378	.0425	-.0152	.0192	.0046	.3454	.0382
-.0974	-.0189	12	.5656	.0318	-.0115	.0107	.0019	.2432	.0784
-.0985	-.0182	14	.6567	.0215	-.0017	.0074	.0008	.1445	.1225
-.0997	-.0180	16	.7474	.0114	-.0179	.0022	.0000	.0247	.1382
-.1001	-.0178	18	.7866	.0090	-.0238	.0013	-.0004	-.0123	.1519
-.1003	-.0173	20	.8521	.0083	-.0318	-.0003	-.0004	-.0300	.1843
-.1003	-.0171	22	.8752	.0089	-.0371	.0009	-.0004	-.0300	.1951
-.1003	-.0170	24	.9002	.0106	-.0519	.0007	-.0003	-.0300	.2078
-.1003	-.0168	26	.8974	.0117	-.0651	.0023	-.0001	-.0300	.2205
M = 0.85									
-.0950	-.0225	-4	-.5478	.0617	.0190	.0335	.0051	.4404	-.1599
-.0951	-.0224	-2	-.4191	.0709	.0185	.0334	.0054	.4322	-.1554
-.0949	-.0224	0	-.2838	.0777	.0181	.0324	.0062	.4469	-.1499
-.0949	-.0221	2	-.1634	.0802	.0179	.0332	.0071	.4502	-.1307
-.0949	-.0217	4	-.0434	.0750	.0162	.0337	.0077	.4535	-.1069
-.0950	-.0210	6	.0929	.0640	.0157	.0380	.0079	.4404	-.0621
-.0955	-.0203	8	.2550	.0535	.0063	.0359	.0065	.3977	-.0192
-.0959	-.0195	10	.4449	.0452	-.0138	.0205	.0032	.3631	.0292
-.0970	-.0187	12	.5786	.0355	-.0142	.0116	.0022	.2662	.0804
-.0981	-.0181	14	.6678	.1625	-.0083	.0021	.0022	.1643	.1216
-.0996	-.0178	16	.7639	.0122	-.0231	.0011	.0001	.0394	.1408
-.0999	-.0175	18	.8092	.0099	-.0333	.0008	-.0002	.0066	.1618
M = 0.90									
-.0940	-.0231	-4	-.5882	.0737	.0551	.0398	.0059	.4979	-.1840
-.0942	-.0230	-2	-.4541	.0821	.0455	.0397	.0057	.4809	-.1823
-.0943	-.0229	0	-.3166	.0856	.0373	.0386	.0062	.4762	-.1711
-.0942	-.0225	2	-.1865	.0871	.0333	.0385	.0070	.4824	-.1522
-.0942	-.0221	4	-.0544	.0804	.0258	.0379	.0078	.4809	-.1281
-.0944	-.0216	6	.0876	.0699	.0210	.0405	.0079	.4669	-.0980
-.0947	-.0210	8	.2485	.0577	.0096	.0398	.0063	.4360	-.0576
-.0957	-.0200	10	.4549	.0436	-.0160	.0211	.0033	.3541	-.0026
-.0965	-.0186	12	.5884	.0379	-.0135	.0160	.0027	.2891	.0869
M = 0.93									
-.0937	-.0228	-4	-.5745	.0855	.0640	.0387	.0071	.5093	-.1650
-.0938	-.0227	-2	-.4339	.0871	.0511	.0383	.0067	.4988	-.1566
-.0935	-.0225	0	-.2987	.0967	.0393	.0378	.0075	.5243	-.1458
-.0934	-.0224	2	-.1665	.0957	.0355	.0385	.0082	.5318	-.1400
-.0934	-.0221	4	-.0386	.0885	.0270	.0394	.0088	.5288	-.1233
-.0936	-.0217	6	.1069	.0799	.0161	.0423	.0083	.5168	-.0966
-.0937	-.0210	8	.2620	.0709	.0012	.0415	.0083	.5063	-.0567
-.0940	-.0196	10	.4299	.0631	-.0099	.0313	.0061	.4793	.0208

TABLE VIII.- AERODYNAMIC CHARACTERISTICS - Continued

(e) $\delta_s = -0.100$; $\frac{\delta_d}{\delta_s} = 0.50$

δ_s, corr	δ_d, corr	α, deg	C_N	C_A	C_m	ΔC_l	ΔC_D	$C_{h,s}$	$C_{h,d}$
M = 0.60									
-.0971	-.0514	-4	-.4653	.0726	.0031	.0257	.0072	.4083	-.1863
-.0970	-.0514	-2	-.3505	.0799	.0049	.0249	.0095	.4214	-.1907
-.0969	-.0514	0	-.2388	.0875	.0094	.0277	.0080	.4292	-.1863
-.0969	-.0513	2	-.1422	.0896	.0137	.0304	.0085	.4371	-.1776
-.0969	-.0512	4	-.0416	.0874	.0168	.0331	.0091	.4397	-.1674
-.0969	-.0511	6	.0741	.0776	.0180	.0341	.0085	.4344	-.1528
-.0971	-.0510	8	.1944	.0666	.0187	.0353	.0074	.4057	-.1412
-.0966	-.0504	10	.3616	.0534	.0066	.0264	.0060	.4711	-.0480
-.0980	-.0508	12	.5208	.0430	-.0066	.0183	.0055	.2800	-.1063
-.0986	-.0506	14	.5957	.0354	.0155	.0147	.0031	.1910	-.0873
-.0994	-.0504	16	.7072	.0248	.0055	.0070	.0016	.0864	-.0597
-.0998	-.0502	18	.7593	.0179	-.0063	.0034	.0007	.0288	-.0335
-.1001	-.0501	20	.8226	.0132	-.0120	-.0016	.0004	-.0105	-.0175
-.1002	-.0501	22	.8428	.0137	-.0159	-.0018	.0002	-.0236	-.0204
-.1002	-.0502	24	.8262	.0159	-.0260	-.0012	.0002	-.0288	-.0247
-.1001	-.0501	26	.8250	.0191	-.0374	.0007	.0005	-.0183	-.0116
M = 0.80									
-.0953	-.0520	-4	-.5001	.0739	.0095	.0263	.0072	.4459	-.1833
-.0952	-.0521	-2	-.3803	.0849	.0138	.0283	.0075	.4494	-.1941
-.0951	-.0522	0	-.2736	.0926	.0176	.0300	.0083	.4600	-.1990
-.0950	-.0527	2	-.1589	.0958	.0213	.0424	.0091	.4688	-.2000
-.0950	-.0521	4	-.0566	.0912	.0235	.0350	.0096	.4688	-.1960
-.0952	-.0520	6	.0569	.0822	.0259	.0379	.0095	.4564	-.1862
-.0957	-.0519	8	.2026	.0704	.0230	.0379	.0079	.4089	-.1725
-.0965	-.0516	10	.3739	.0557	.0121	.0255	.0051	.3278	-.1510
-.0974	-.0515	12	.4908	.0496	.0080	.0172	.0034	.2502	-.1382
-.0983	-.0512	14	.6119	.0372	.0116	.0122	.0025	.1621	-.1098
-.0994	-.0509	16	.7009	.0246	.0264	.0067	.0013	.0599	-.0823
-.0997	-.0507	18	.7774	.0203	-.0143	.0022	.0008	.0282	-.0647
-.1001	-.0506	20	.8094	.0165	-.0204	.0026	.0003	-.0070	-.0539
-.1002	-.0505	22	.8449	.0175	-.0284	.0020	.0003	-.0159	-.0480
-.1002	-.0504	24	.8671	.0181	-.0416	.0027	.0003	-.0176	-.0372
-.1002	-.0502	26	.8877	.0169	-.0554	.0026	.0003	-.0194	-.0186
M = 0.85									
-.0947	-.0524	-4	-.5343	.0795	.0182	.0296	.0069	.4698	-.2083
-.0947	-.0525	-2	-.4079	.0896	.0221	.0303	.0072	.4714	-.2138
-.0945	-.0525	0	-.2843	.0978	.0245	.0310	.0081	.4846	-.2174
-.0945	-.0525	2	-.1796	.1001	.0266	.0326	.0089	.4879	-.2165
-.0945	-.0524	4	-.0588	.0943	.0271	.0341	.0095	.4879	-.2065
-.0947	-.0523	6	.0592	.0845	.0292	.0399	.0098	.4681	-.1964
-.0952	-.0522	8	.310	.0738	.0237	.0347	.0086	.4189	-.1891
-.0961	-.0519	10	.3847	.0635	.0079	.0261	.0046	.3466	-.1672
-.0970	-.0518	12	.4948	.0555	.0121	.0202	.0042	.2677	-.1581
-.0980	-.0514	14	.6093	.0405	.0095	.0134	.0025	.1741	-.1197
-.0992	-.0511	16	.7160	.0279	-.0047	.0059	.0015	.0739	-.0941
-.0997	-.0509	18	.7782	.0224	-.0192	.0025	.0010	.0263	-.0767
M = 0.90									
-.0940	-.0527	-4	-.5460	.0883	.0317	.0321	.0069	.4991	-.2157
-.0941	-.0527	-2	-.4173	.0964	.0279	.0324	.0070	.4898	-.2217
-.0940	-.0527	0	-.2903	.1025	.0278	.0332	.0078	.4975	-.2217
-.0939	-.0527	2	-.1738	.0388	.0339	.0381	.0078	.5022	-.2217
-.0940	-.0527	4	-.0603	.0987	.0319	.0377	.0094	.4991	-.2140
-.0942	-.0526	6	.0589	.0894	.0352	.0423	.0097	.4805	-.2063
-.0946	-.0525	8	.2008	.0808	.0305	.0445	.0086	.4450	-.2002
-.0958	-.0524	10	.3706	.0672	.0145	.0298	.0057	.3492	-.1917
-.0968	-.0521	12	.4957	.0594	.0194	.0258	.0048	.2642	-.1702
M = 0.93									
-.0937	-.0530	-4	-.5353	.0969	.0421	.0327	.0076	.5090	-.2306
-.0938	-.0530	-2	-.4136	.1060	.0378	.0344	.0077	.5000	-.2356
-.0936	-.0531	0	-.2881	.1142	.0361	.0359	.0088	.5164	-.2440
-.0935	-.0531	2	-.1757	.1149	.0374	.0379	.0097	.5254	-.2398
-.0936	-.0529	4	-.0521	.1055	.0349	.0406	.0097	.5104	-.2281
-.0939	-.0528	6	.3583	.0929	.0360	.0409	.0096	.4910	-.2190
-.0940	-.0527	8	.2035	.0914	.0311	.0488	.0102	.4820	-.2115
-.0943	-.0525	10	.3486	.0874	.0241	.0399	.0084	.4581	-.1973

TABLE VIII.- AERODYNAMIC CHARACTERISTICS - Continued

$$(f) \delta_s = -0.100; \frac{d\delta}{\delta_s} = 0.75$$

δ_s, corr	δ_d, corr	α , deg	C_N	C_A	C_m	ΔC_l	ΔC_n	$C_{h,s}$	$C_{h,d}$
M = 0.60									
-.0977	-.0764	-4	-.4578	.0927	.0108	.0265	.0090	.3185	-.2236
-.0978	-.0765	-2	-.3568	.1013	.0174	.0283	.0090	.3133	-.2338
-.0977	-.0765	0	-.2090	.1086	.0228	.0306	.0099	.3159	-.2396
-.0977	-.0765	2	-.1642	.1119	.0274	.0340	.0105	.3238	-.2454
-.0977	-.0765	4	-.0682	.1103	.0310	.0378	.0113	.3238	-.2483
-.0977	-.0765	6	.0393	.1032	.0326	.0557	.0107	.3211	-.2454
-.0979	-.0765	8	.1523	.0912	.0333	.0409	.0097	.3003	-.2382
-.0982	-.0764	10	.3188	.0825	.0199	.0318	.0084	.2480	-.2295
-.0986	-.0764	12	.4772	.0671	.0047	.0234	.0077	.1932	-.2193
-.0993	-.0763	14	.5287	.0602	.0342	.0230	.0054	.0966	-.2135
-.0999	-.0762	16	.6300	.0503	.0225	.0161	.0039	.0261	-.1946
-.1003	-.0761	18	.7069	.0437	.0111	.0110	.0033	-.0392	-.1772
-.1005	-.0760	20	.7603	.0390	.0059	.0069	.0030	-.0653	-.1656
-.1005	-.0760	22	.7899	.0411	.0028	.0053	.0029	-.0731	-.1670
-.1005	-.0761	24	.7843	.0433	-.0068	.0064	.0031	-.0757	-.1685
-.1005	-.0760	26	.8047	.0461	.0233	.0058	.0032	-.0731	-.1656
M = 0.80									
-.0958	-.0770	-4	-.4842	.0943	.0113	.0244	.0093	.3968	-.2178
-.0958	-.0771	-2	-.3675	.1020	.0163	.0267	.0093	.3950	-.2285
-.0958	-.0771	0	-.2667	.1087	.0235	.0295	.0101	.4021	-.2315
-.0957	-.0772	2	-.1661	.1113	.0284	.0326	.0107	.4091	-.2334
-.0956	-.0772	4	-.0623	.1082	.0322	.0362	.0114	.4127	-.2384
-.0958	-.0772	6	.0416	.1000	.0366	.0399	.0113	.4003	-.2413
-.0963	-.0773	8	.1710	.0919	.0360	.0412	.0102	.3527	-.2472
-.0971	-.0772	10	.3514	.0788	.0182	.0274	.0078	.2751	-.2423
-.0980	-.0773	12	.4384	.0753	.0327	.0244	.0063	.1905	-.2472
-.0988	-.0771	14	.5448	.0633	.0317	.0189	.0052	.1093	-.2305
-.0998	-.0770	16	.6360	.0527	.0206	.0138	.0043	.0229	-.2168
-.1000	-.0768	18	.7007	.0493	.0088	.0098	.0039	.0018	-.2001
-.1002	-.0768	20	.7695	.0464	.0008	.0078	.0037	-.0212	-.1913
-.1002	-.0767	22	.7823	.0464	-.0036	.0093	.0034	-.0229	-.1805
-.1002	-.0766	24	.8041	.0463	-.0168	.0094	.0034	-.0229	-.1736
M = 0.85									
-.0953	-.0773	-4	-.4847	.0949	.0058	.0231	.0087	.4126	-.2286
-.0953	-.0773	-2	-.3759	.1062	.0164	.0259	.0092	.4126	-.2368
-.0952	-.0774	0	-.2668	.1126	.0236	.0286	.0098	.4208	-.2386
-.0952	-.0774	2	-.1670	.1151	.0297	.0318	.0106	.4274	-.2405
-.0952	-.0774	4	-.0580	.1107	.0327	.0348	.0113	.4274	-.2423
-.0952	-.0775	6	.0536	.1036	.0368	.0404	.0119	.4192	-.2505
-.0958	-.0775	8	.1955	.0970	.0344	.0414	.0106	.3666	-.2523
-.0968	-.0775	10	.3638	.0811	.0168	.0277	.0064	.2794	-.2542
-.0976	-.0776	12	.4509	.0780	.0306	.0253	.0065	.2088	-.2587
-.0985	-.0774	14	.5627	.0664	.0293	.0190	.0054	.1315	-.2459
-.0995	-.0772	16	.6294	.0540	.0193	.0146	.0044	.0444	-.2185
-.0999	-.0771	18	.7202	.0527	.0047	.0097	.0043	.0099	-.2149
M = 0.90									
-.0946	-.0777	-4	-.5085	.1058	.0147	.0265	.0090	.4484	-.2571
-.0948	-.0777	-2	-.3813	.1130	.0209	.0280	.0090	.4345	-.2597
-.0947	-.0777	0	-.2648	.1185	.0258	.0305	.0098	.4360	-.2571
-.0947	-.0777	2	-.1681	.1196	.0324	.0343	.0101	.4391	-.2554
-.0947	-.0776	4	-.0544	.1141	.0353	.0372	.0111	.4376	-.2511
-.0949	-.0777	6	.0593	.1065	.0396	.0424	.0116	.4206	-.2571
-.0954	-.0778	8	.1951	.0982	.0334	.0447	.0103	.3835	-.2683
-.0964	-.0779	10	.3699	.0851	.0143	.0285	.0077	.2969	-.2752
-.0973	-.0780	12	.4626	.0853	.0341	.0293	.0077	.2227	-.2855
-.0985	-.0778	14	.5832	.0717	.0255	.0162	.0059	.1283	-.2657
M = 0.93									
-.0943	-.0779	-4	-.5053	.1104	.0239	.0270	.0093	.4554	-.2649
-.0945	-.0780	-2	-.3824	.1204	.0273	.0295	.0096	.4449	-.2741
-.0944	-.0781	0	-.2730	.1304	.0319	.0328	.0107	.4494	-.2824
-.0943	-.0780	2	-.1629	.1281	.0346	.0354	.0114	.4554	-.2741
-.0944	-.0780	4	-.0529	.1228	.0370	.0394	.0120	.4494	-.2741
-.0947	-.0779	6	.0514	.1130	.0405	.0460	.0118	.4299	-.2699
-.0951	-.0780	8	.1941	.1028	.0346	.0478	.0109	.3955	-.2783
-.0961	-.0782	10	.3593	.0955	.0173	.0346	.0085	.3146	-.2908

TABLE VIII.- AERODYNAMIC CHARACTERISTICS - Concluded

(g) $\delta_s = -0.100$; $\frac{\delta_d}{\delta_s} = 1.00$

δ_s, corr	δ_d, corr	α, deg	C_N	C_A	C_m	ΔC_l	ΔC_n	$C_{h,s}$	$C_{h,d}$
M = 0.60									
-.0972	-.1014	-4	-.4364	.1092	.0007	.0201	.0110	.3867	-.2681
-.0972	-.1014	-2	-.3313	.1156	.0096	.0221	.0108	.3918	-.2696
-.0971	-.1014	0	-.2544	.1265	.0226	.0280	.0118	.3996	-.2782
-.0971	-.1015	2	-.1778	.1277	.0342	.0329	.0123	.4021	-.2825
-.0971	-.1014	4	-.0733	.1244	.0365	.0361	.0130	.3996	-.2782
-.0972	-.1014	6	.0259	.1169	.0368	.0381	.0125	.3918	-.2767
-.0974	-.1014	8	.1442	.1071	.0371	.0394	.0115	.3583	-.2782
-.0979	-.1014	10	.3094	.0952	.0248	.0314	.0102	.2861	-.2796
-.0985	-.1014	12	.4615	.0850	.0136	.0241	.0096	.2062	-.2782
-.0990	-.1014	14	.5025	.0847	.0417	.0243	.0080	.1315	-.2782
-.0996	-.1014	16	.5785	.0792	.0357	.0193	.0071	.0619	-.2782
-.0999	-.1014	18	.6502	.0755	.0275	.0153	.0067	.0103	-.2681
-.1001	-.1013	20	.7167	.0723	.0201	.0091	.0065	-.0103	-.2595
-.1001	-.1013	22	.7315	.0756	.0188	.0088	.0065	-.0077	-.2466
-.1000	-.1013	24	.7303	.0771	.0106	.0088	.0067	-.0026	-.2438
-.1000	-.1012	26	.7432	.0781	-.0015	.0089	.0067	-.0026	-.2395
M = 0.80									
-.0960	-.1021	-4	-.4463	.1104	.0010	.0191	.0113	.3769	-.2725
-.0959	-.1022	-2	-.3442	.1177	.0072	.0228	.0111	.3787	-.2811
-.0958	-.1022	0	-.2506	.1255	.0194	.0270	.0120	.3891	-.2860
-.0957	-.1022	2	-.1633	.1284	.0326	.0324	.0126	.3995	-.2840
-.0957	-.1021	4	-.0545	.1227	.0364	.0355	.0130	.4012	-.2744
-.0958	-.1021	6	.0506	.1149	.0382	.0389	.0130	.3891	-.2754
-.0964	-.1022	8	.1784	.1066	.0387	.0407	.0119	.3318	-.2811
-.0972	-.1022	10	.3314	.0986	.0278	.0305	.0101	.2605	-.2898
-.0983	-.1023	12	.4223	.0940	.0381	.0257	.0082	.1581	-.3043
-.0991	-.1024	14	.5052	.0891	.0440	.0230	.0079	.0799	-.3121
-.0998	-.1024	16	.5694	.0850	.0367	.0205	.0078	.0156	-.3092
-.1000	-.1023	18	.6429	.0831	.0257	.0157	.0074	-.0000	-.2927
-.1001	-.1021	20	.7069	.0791	.0161	.0134	.0070	-.0139	-.2763
-.1001	-.1021	22	.7390	.0800	.0097	.0133	.0071	-.0104	-.2667
-.1001	-.1020	24	.7605	.0814	.0019	.0131	.0071	-.0104	-.2589
M = 0.85									
-.0957	-.1023	-4	-.4545	.1088	-.0037	.0191	.0105	.3772	-.2765
-.0956	-.1024	-2	-.3469	.1216	.0084	.0225	.0110	.3837	-.2900
-.0955	-.1024	0	-.2509	.1288	.0190	.0270	.0117	.3918	-.2918
-.0954	-.1024	2	-.1578	.1307	.0299	.0317	.0124	.4015	-.2864
-.0954	-.1023	4	-.0443	.1254	.0329	.0344	.0129	.3999	-.2801
-.0954	-.1023	6	.0623	.1171	.0374	.0402	.0134	.3983	-.2819
-.0962	-.1023	8	.1966	.1086	.0377	.0425	.0123	.3319	-.2846
-.0971	-.1024	10	.3545	.1017	.0270	.0307	.0088	.2542	-.2954
-.0981	-.1025	12	.4240	.0965	.0380	.0286	.0085	.1635	-.3089
-.0991	-.1026	14	.5018	.0917	.0443	.0261	.0081	.0810	-.3170
-.0998	-.1027	16	.5767	.0887	.0353	.0211	.0080	.0146	-.3224
-.0999	-.1025	18	.6354	.0866	.0231	.0182	.0079	.0049	-.3053
M = 0.90									
-.0953	-.1026	-4	-.4741	.1178	.0012	.0219	.0108	.3823	-.2965
-.0952	-.1027	-2	-.3540	.1458	.0132	.0244	.0114	.3884	-.3100
-.0970	-.1027	0	-.2493	.1386	.0248	.0292	.0120	.2482	-.3134
-.0950	-.1026	2	-.1454	.1374	.0321	.0325	.0125	.4127	-.3016
-.0951	-.1026	4	-.0387	.1305	.0356	.0365	.0131	.4005	-.2965
-.0953	-.1026	6	.0679	.1227	.0424	.0426	.0137	.3853	-.2982
-.0958	-.1026	8	.1988	.1149	.0389	.0451	.0125	.3427	-.2999
-.0968	-.1028	10	.3279	.1100	.0403	.0390	.0112	.2650	-.3177
-.0980	-.1029	12	.4480	.1039	.0404	.0313	.0099	.1660	-.3346
M = 0.93									
-.0951	-.1029	-4	-.4719	.1265	.0079	.0226	.0116	.3866	-.3184
-.0950	-.1030	-2	-.3500	.1393	.0149	.0260	.0122	.3954	-.3348
-.0948	-.1031	0	-.2468	.1494	.0253	.0307	.0134	.4146	-.3447
-.0947	-.1031	2	-.1457	.1505	.0346	.0350	.0139	.4234	-.3404
-.0947	-.1030	4	-.0425	.1423	.0401	.0399	.0143	.4175	-.3324
-.0950	-.1029	6	.0689	.1326	.0443	.0465	.0140	.3998	-.3217
-.0956	-.1029	8	.2067	.1210	.0387	.0487	.0132	.3497	-.3160
-.0966	-.1030	10	.3632	.1123	.0229	.0353	.0105	.2715	-.3348

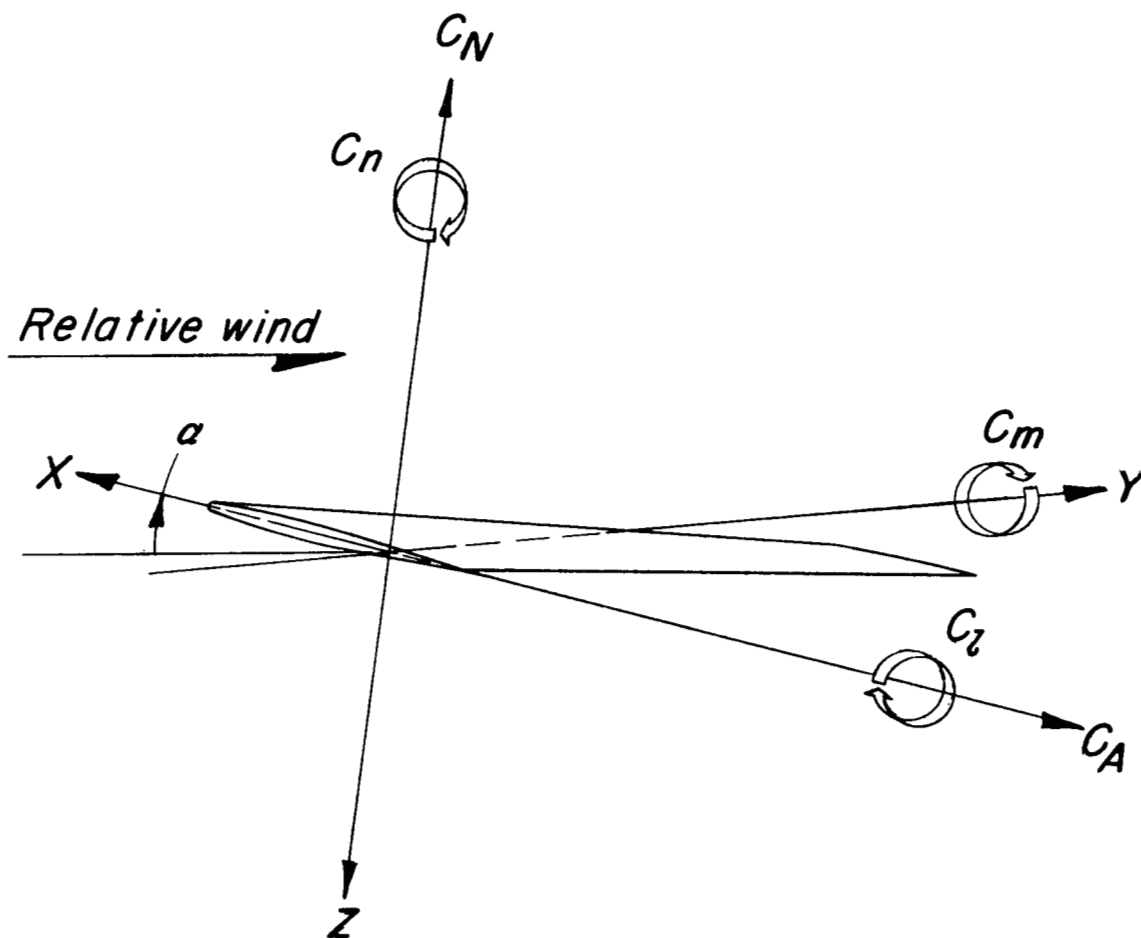


Figure 1.- System of body axes. Positive values of forces, moments, and angles are indicated by arrows.

TABULATED WING DATA

Area (twice semispan)	4.00 sq ft
Aspect ratio	4.00
Taper ratio	0.60
Mean aerodynamic chord	1.02 ft
Airfoil section	NACA 65A006

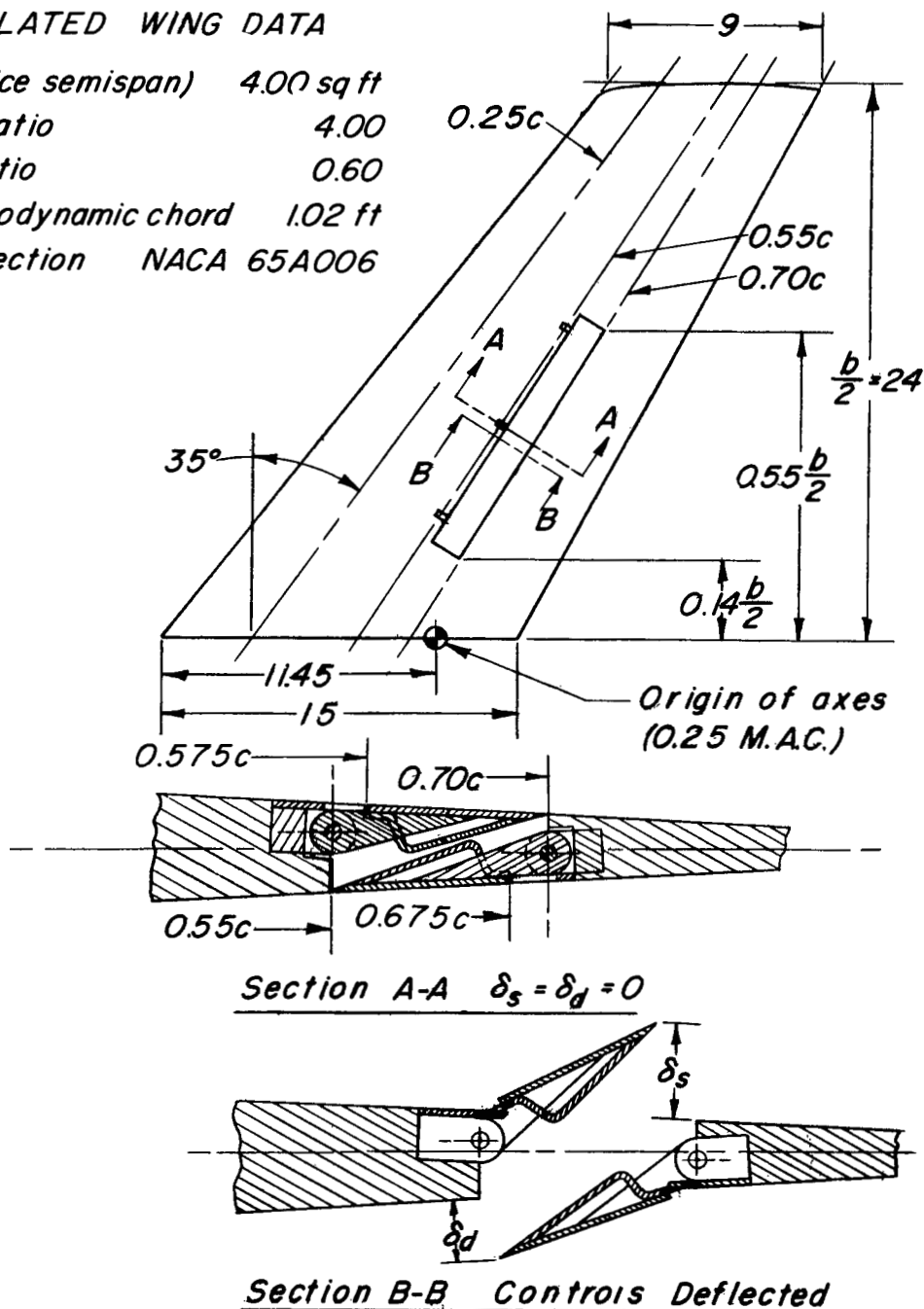


Figure 2.- Geometric characteristics of the 35° sweptback wing equipped with a spoiler slot deflector. All dimensions are in inches unless otherwise noted.

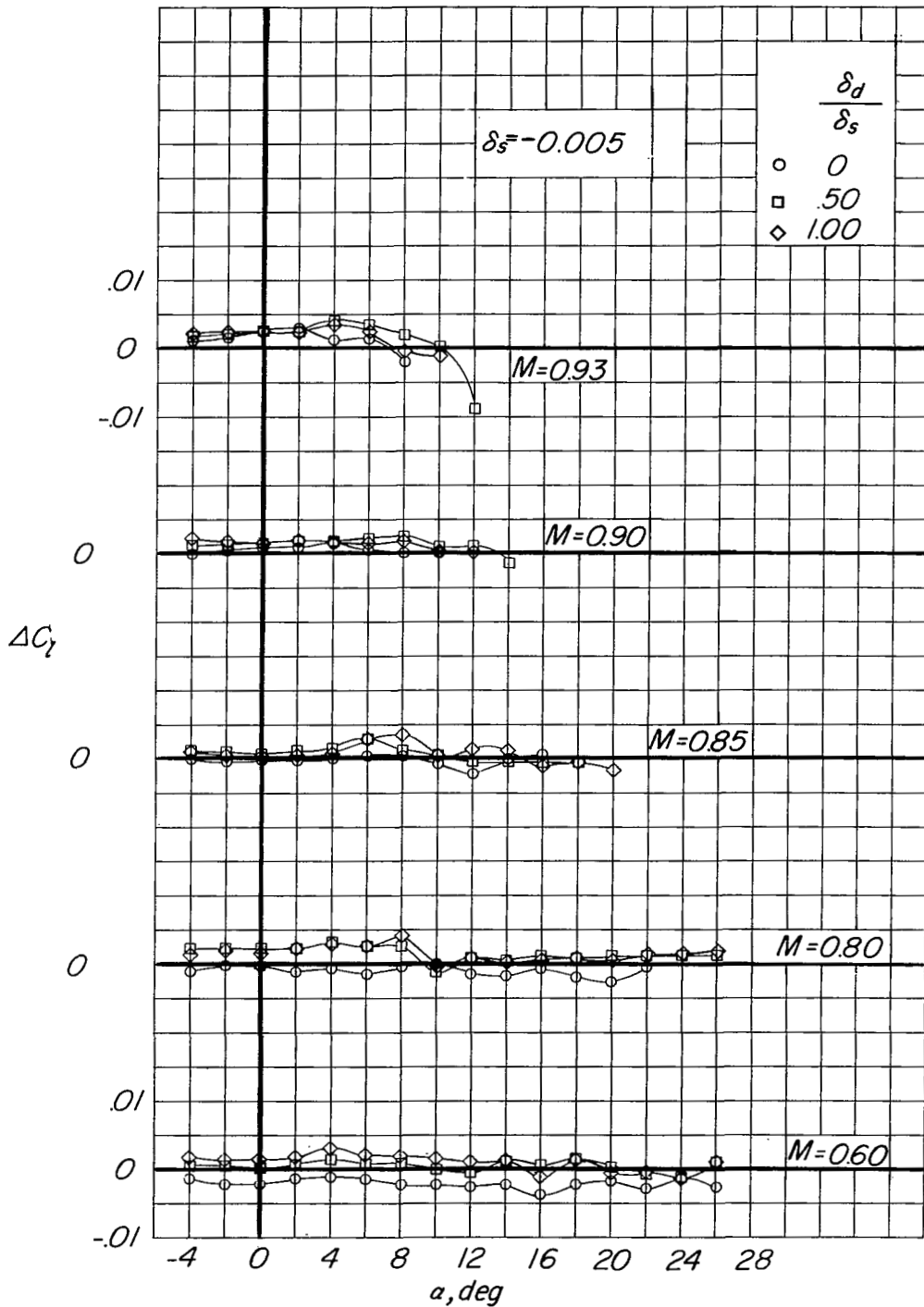


Figure 3.- Variation of the rolling moment produced by the spoiler slot deflector with angle of attack at various control projections.

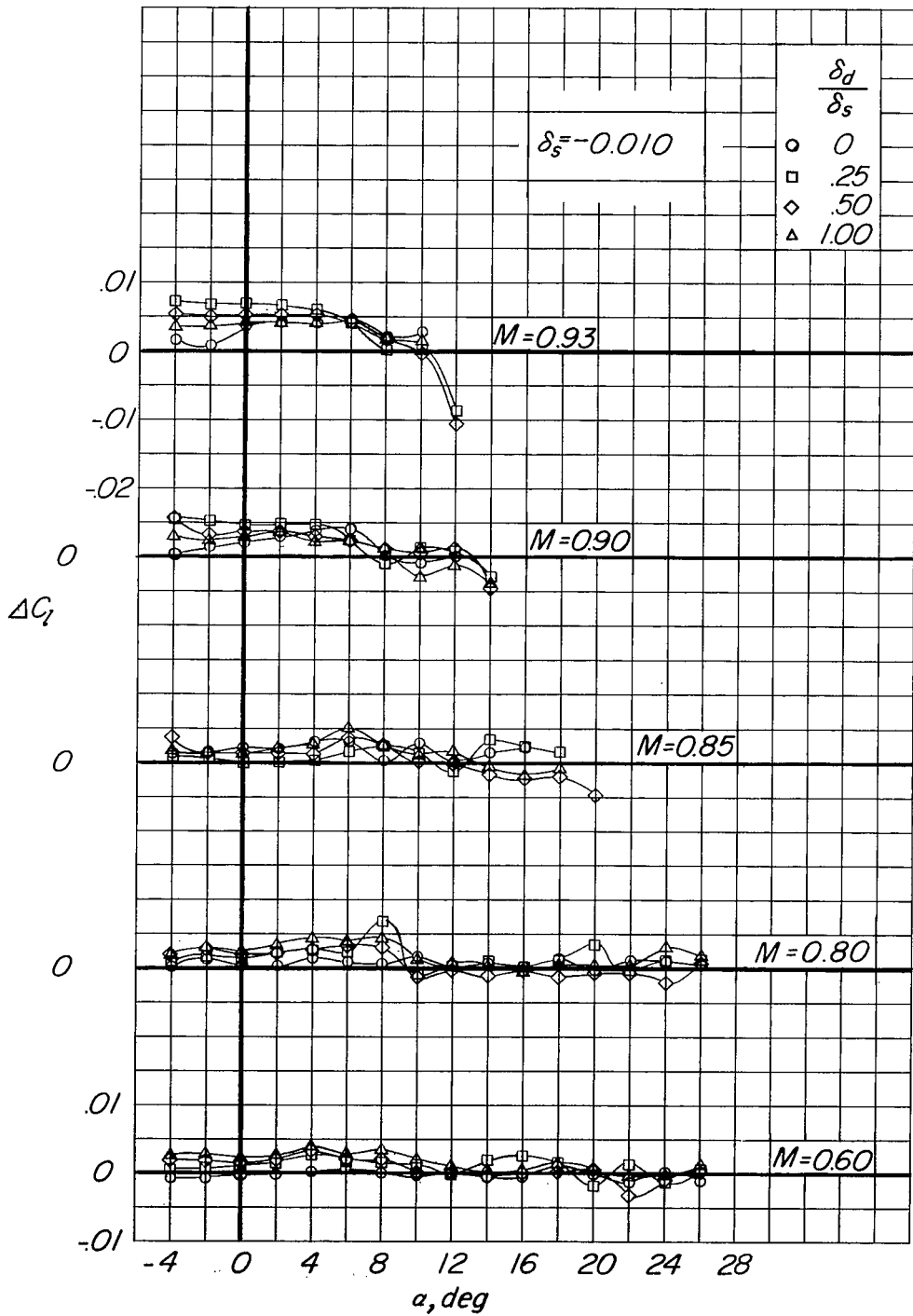


Figure 3.- Continued.

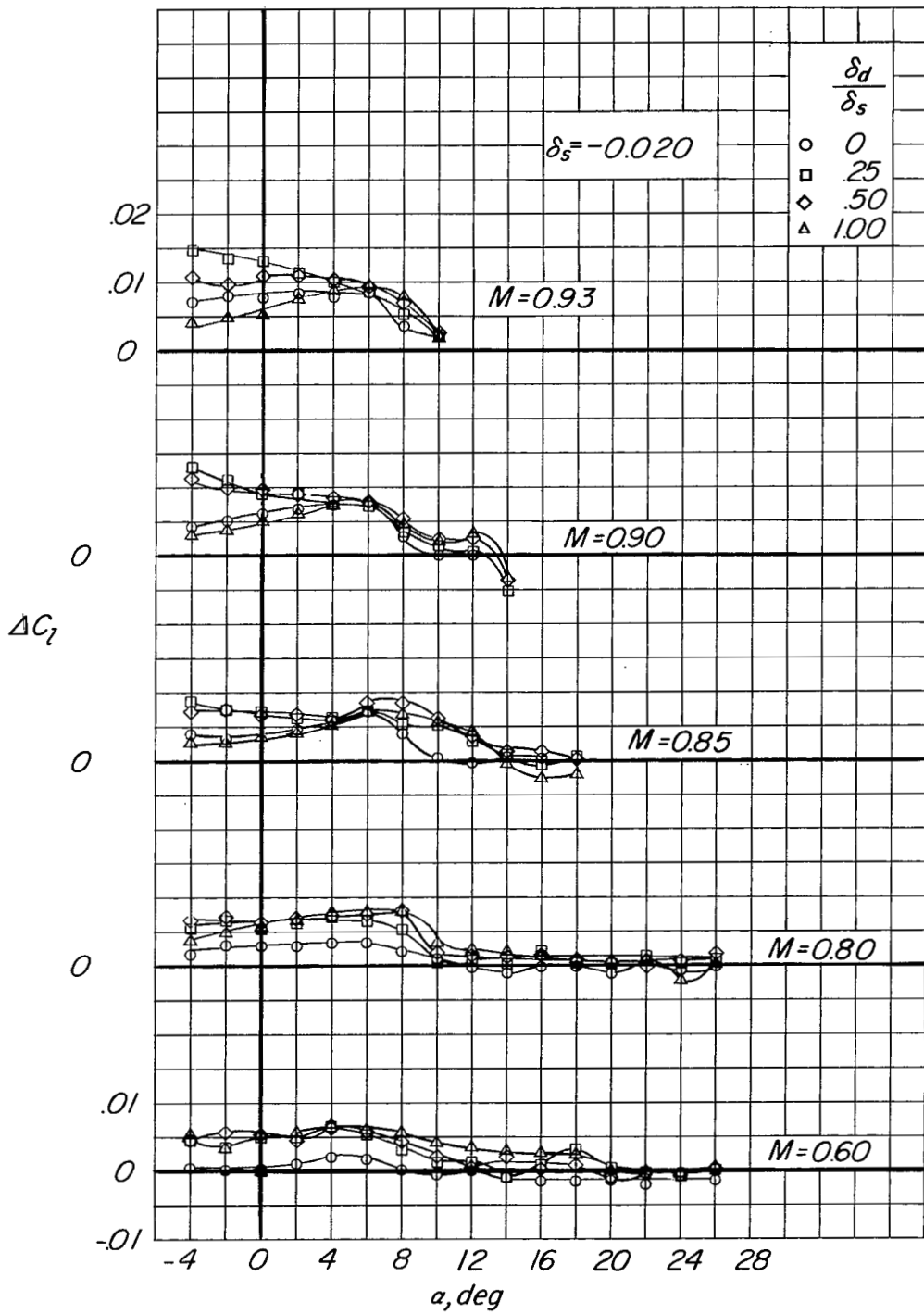


Figure 3.- Continued.

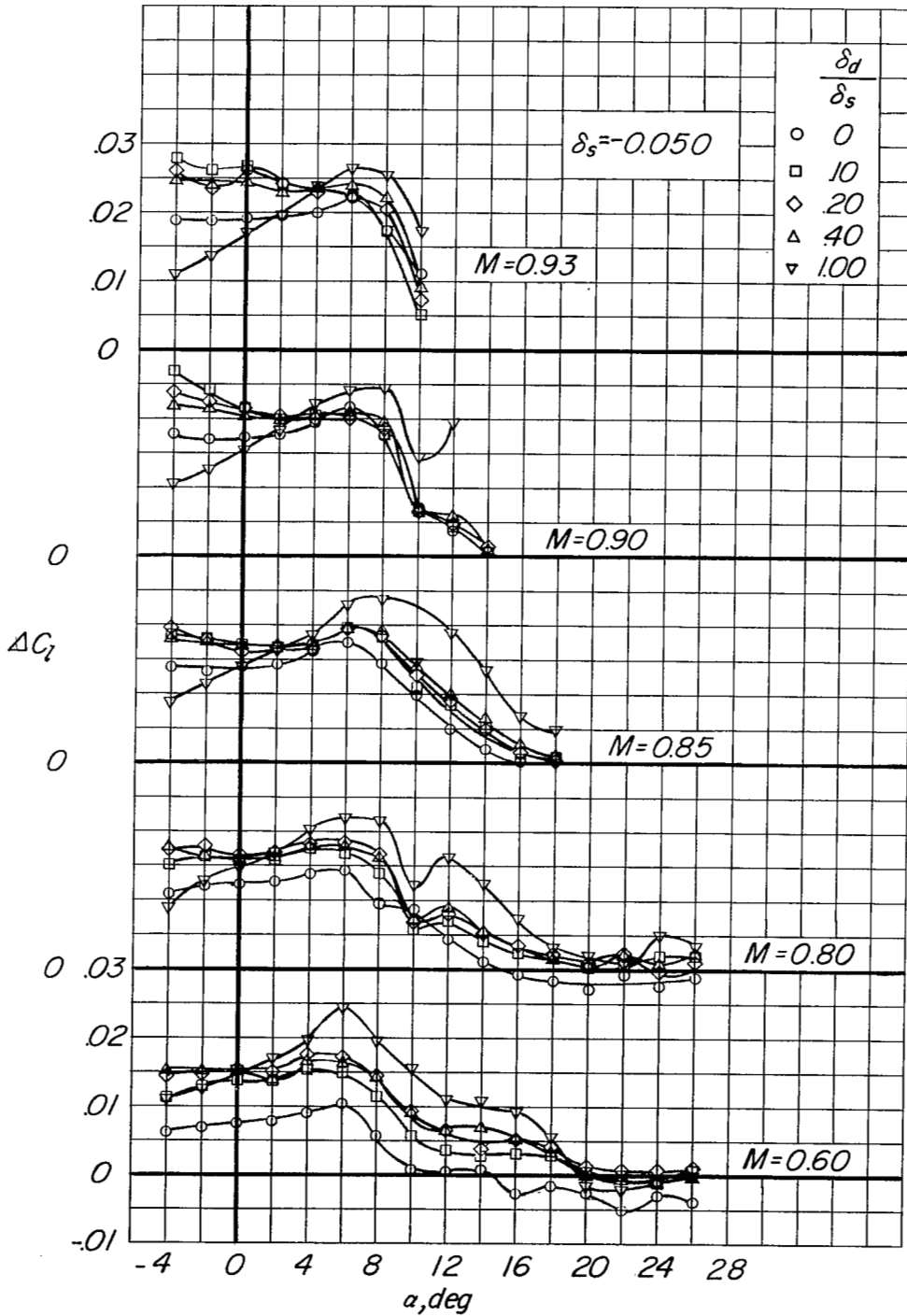


Figure 3.- Continued.

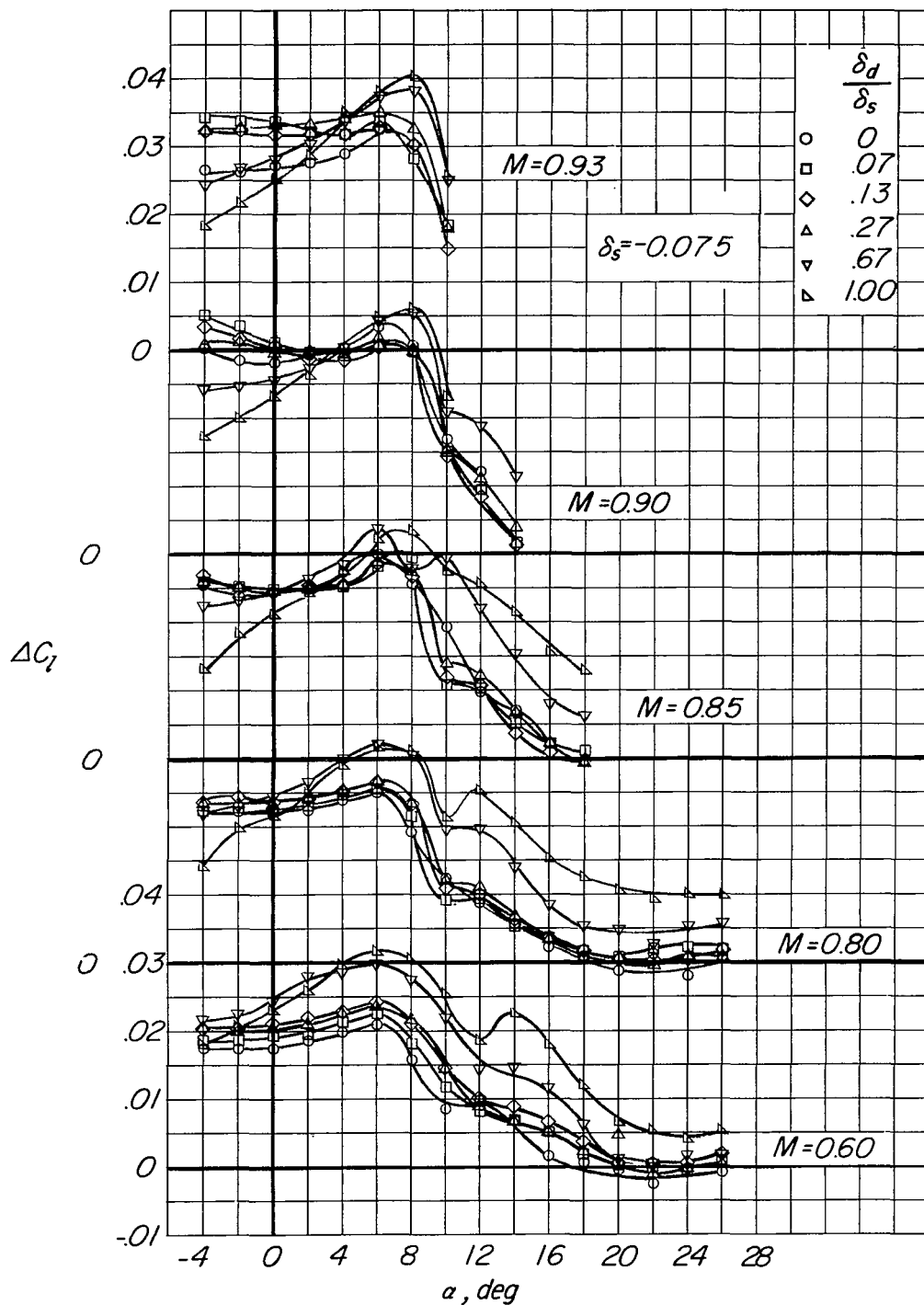


Figure 3.- Continued.

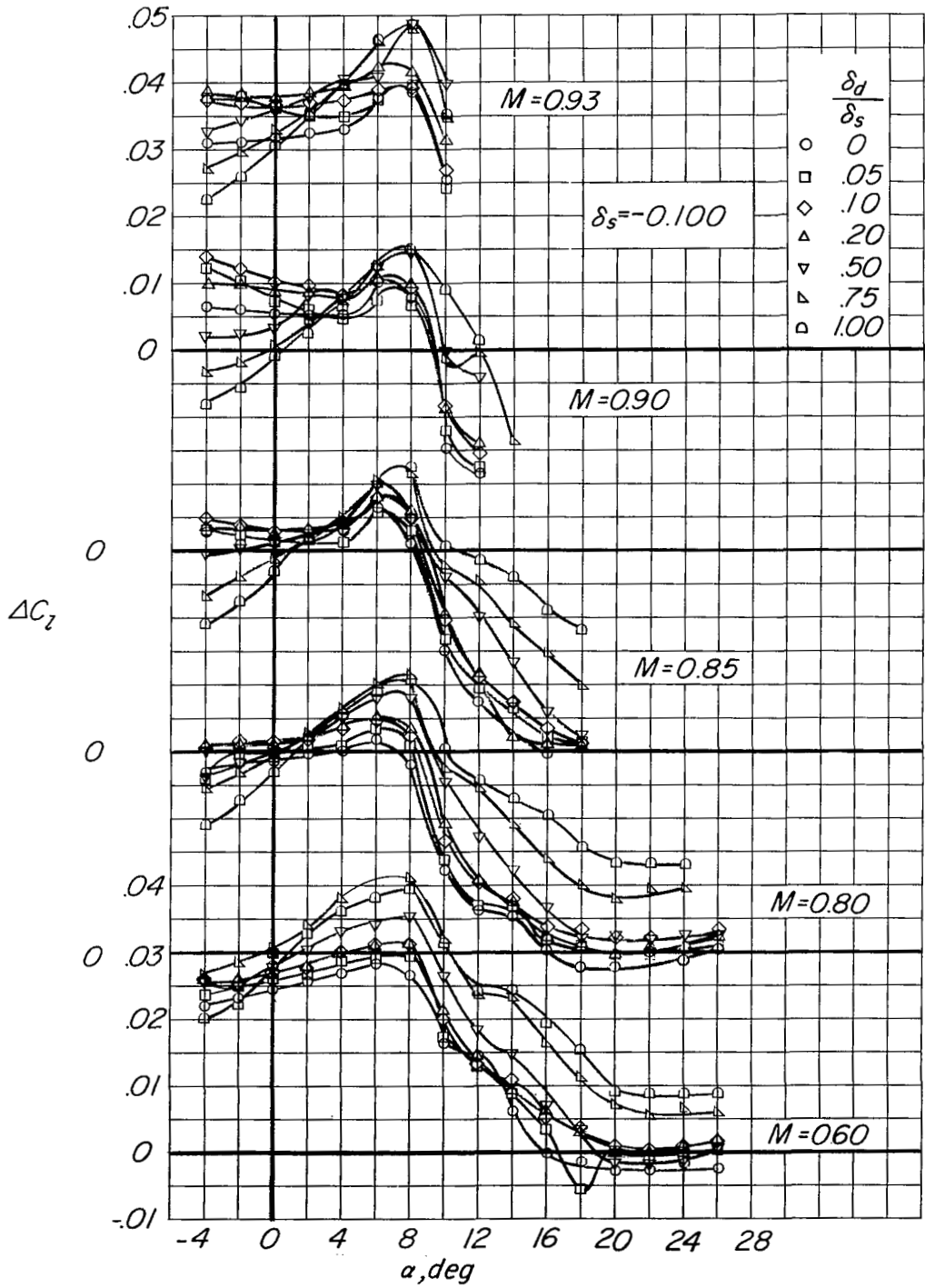


Figure 3.- Concluded.

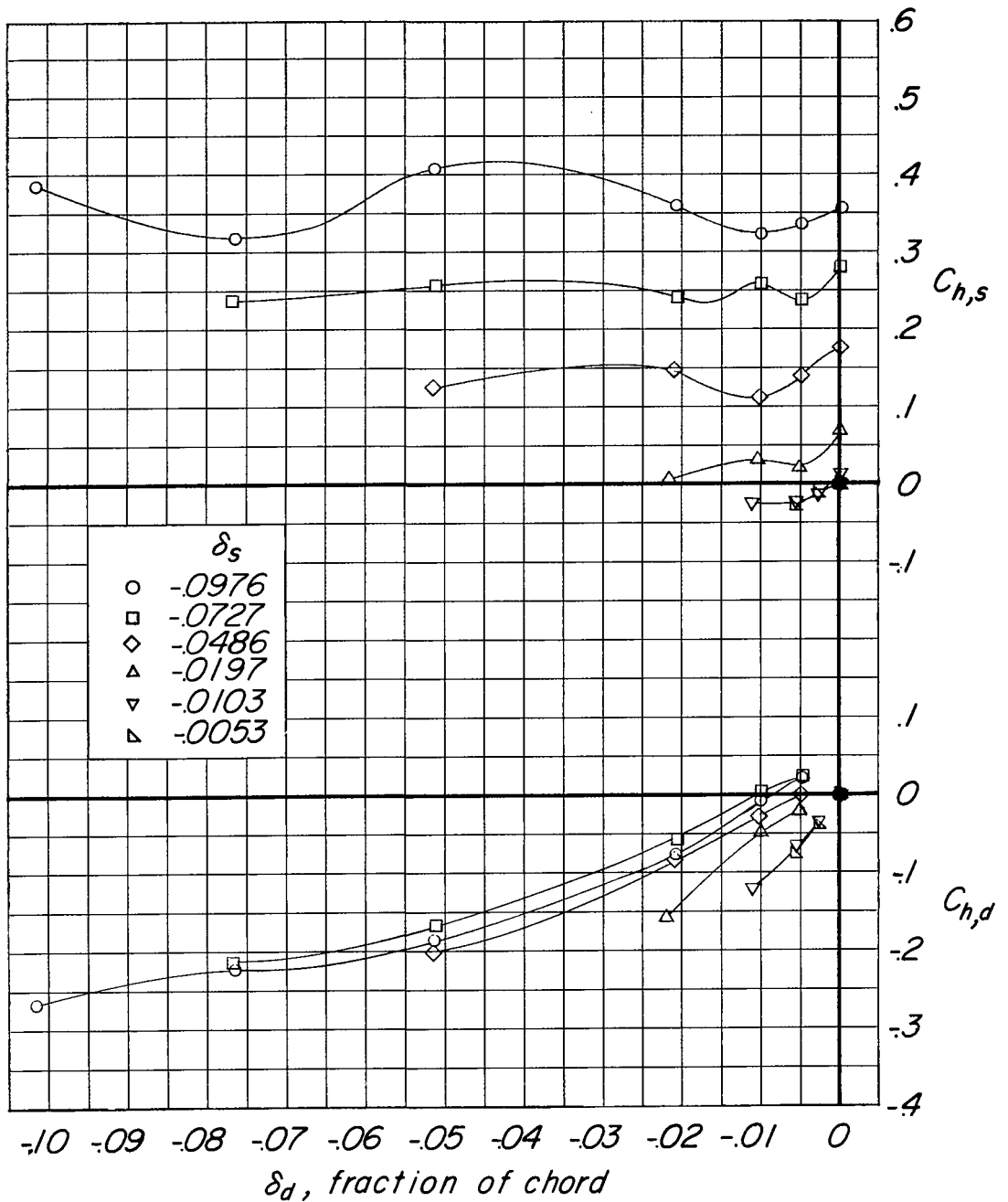
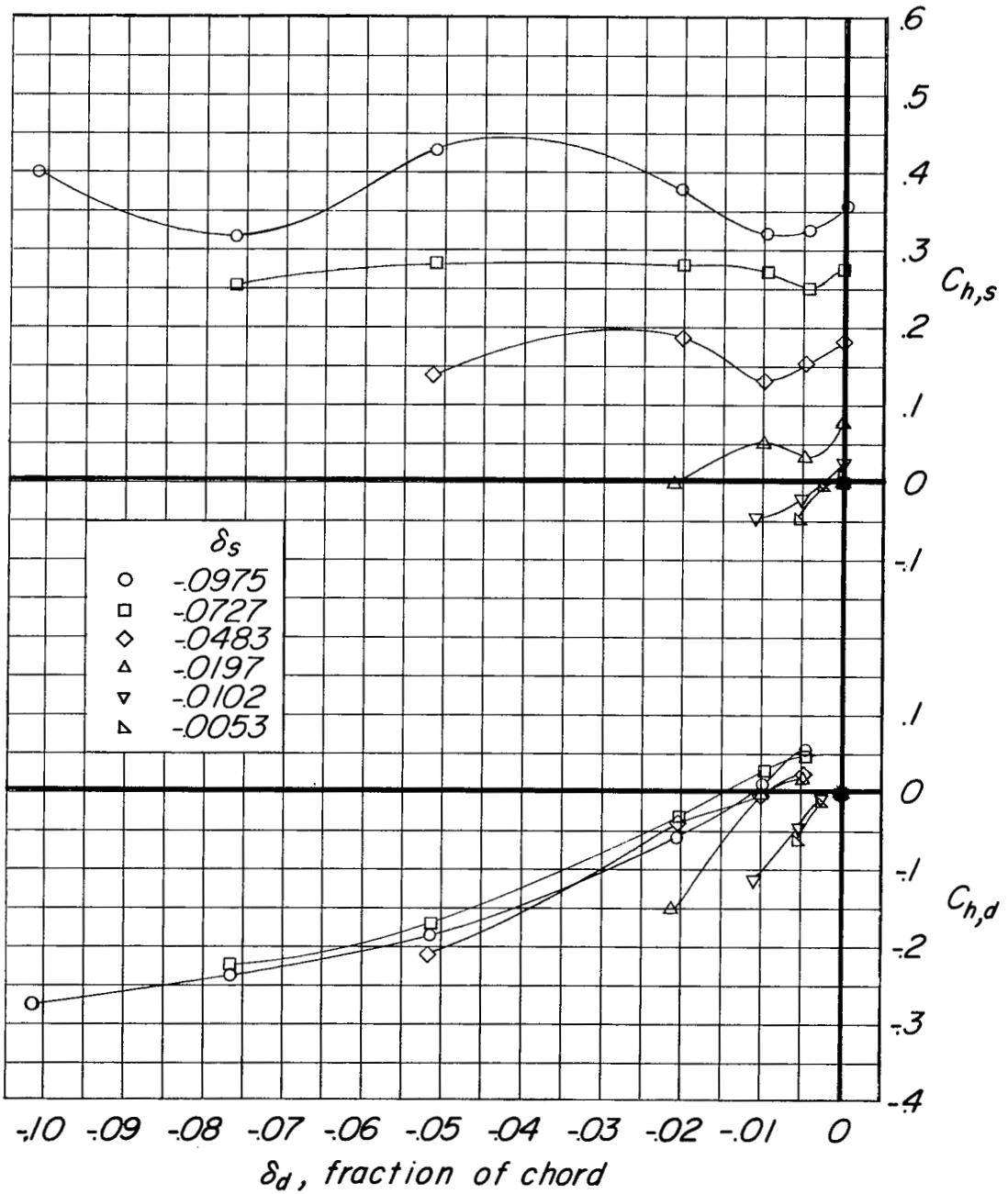
(a) $\alpha = -4^\circ$.

Figure 4.- Variation of hinge-moment characteristics with deflector projection of the spoiler and deflector for a 35° sweptback wing at a Mach number of 0.60.



(b) $\alpha = 0^\circ$.

Figure 4.- Continued.

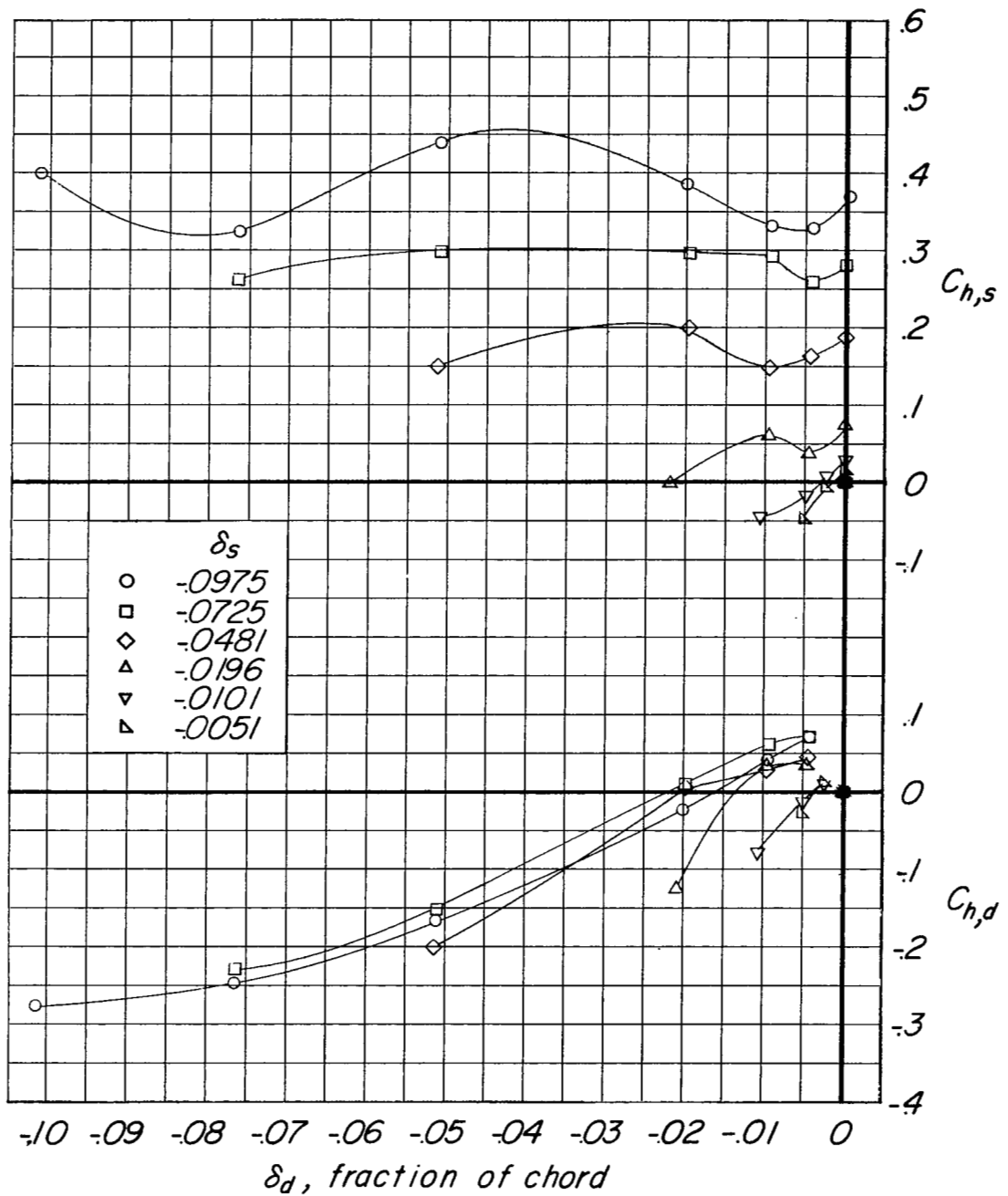
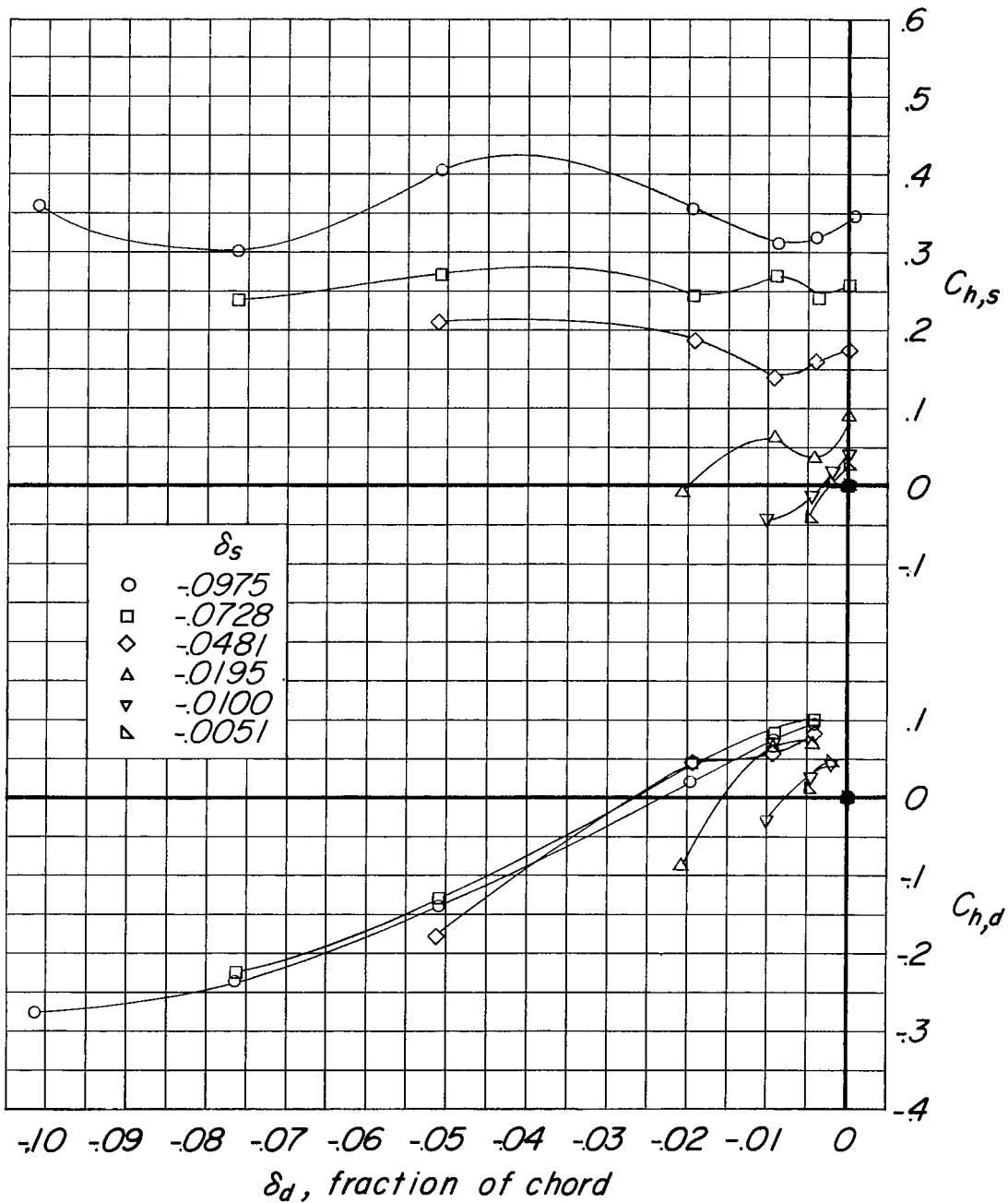
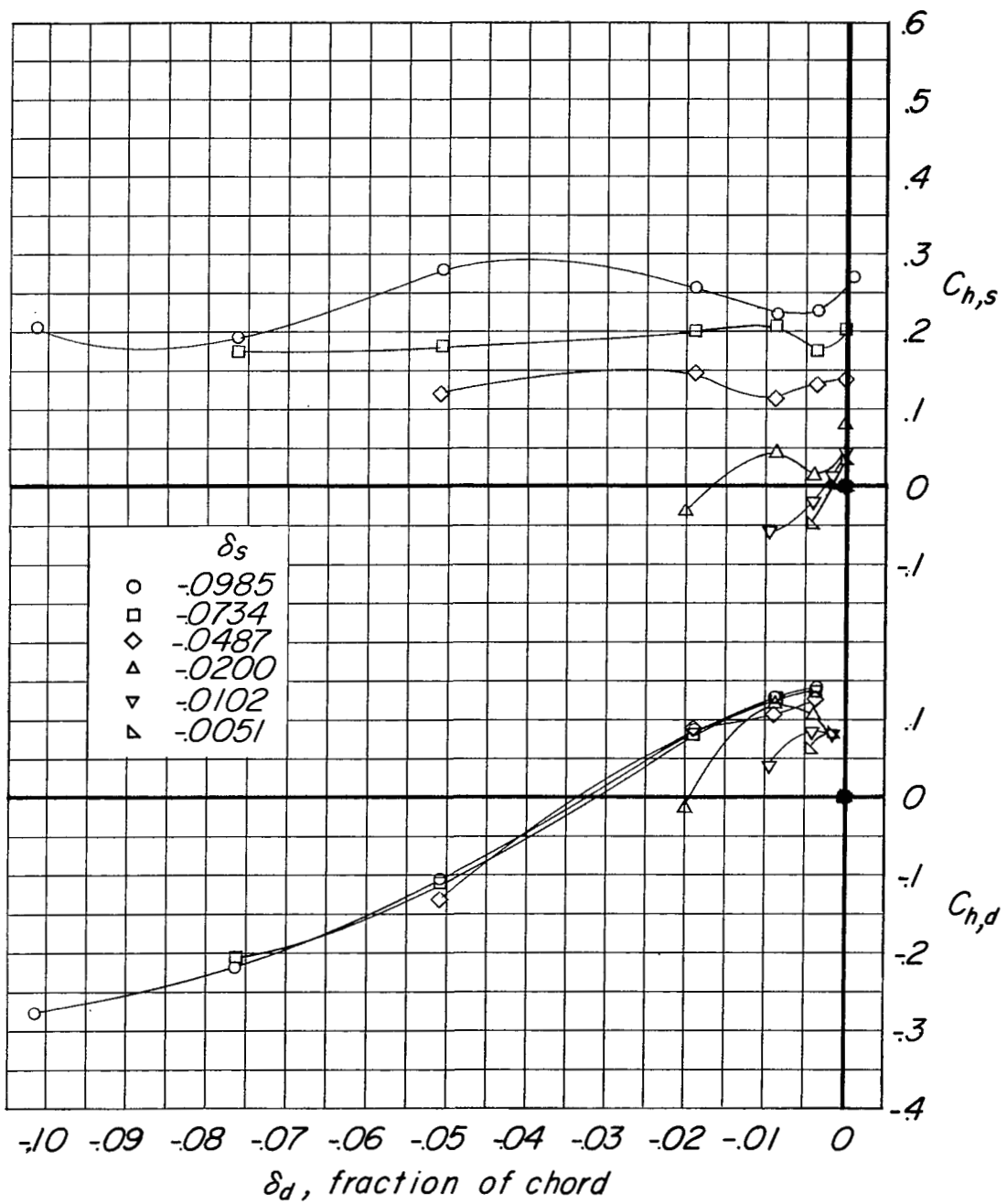
(c) $\alpha = 4^\circ$.

Figure 4.- Continued.



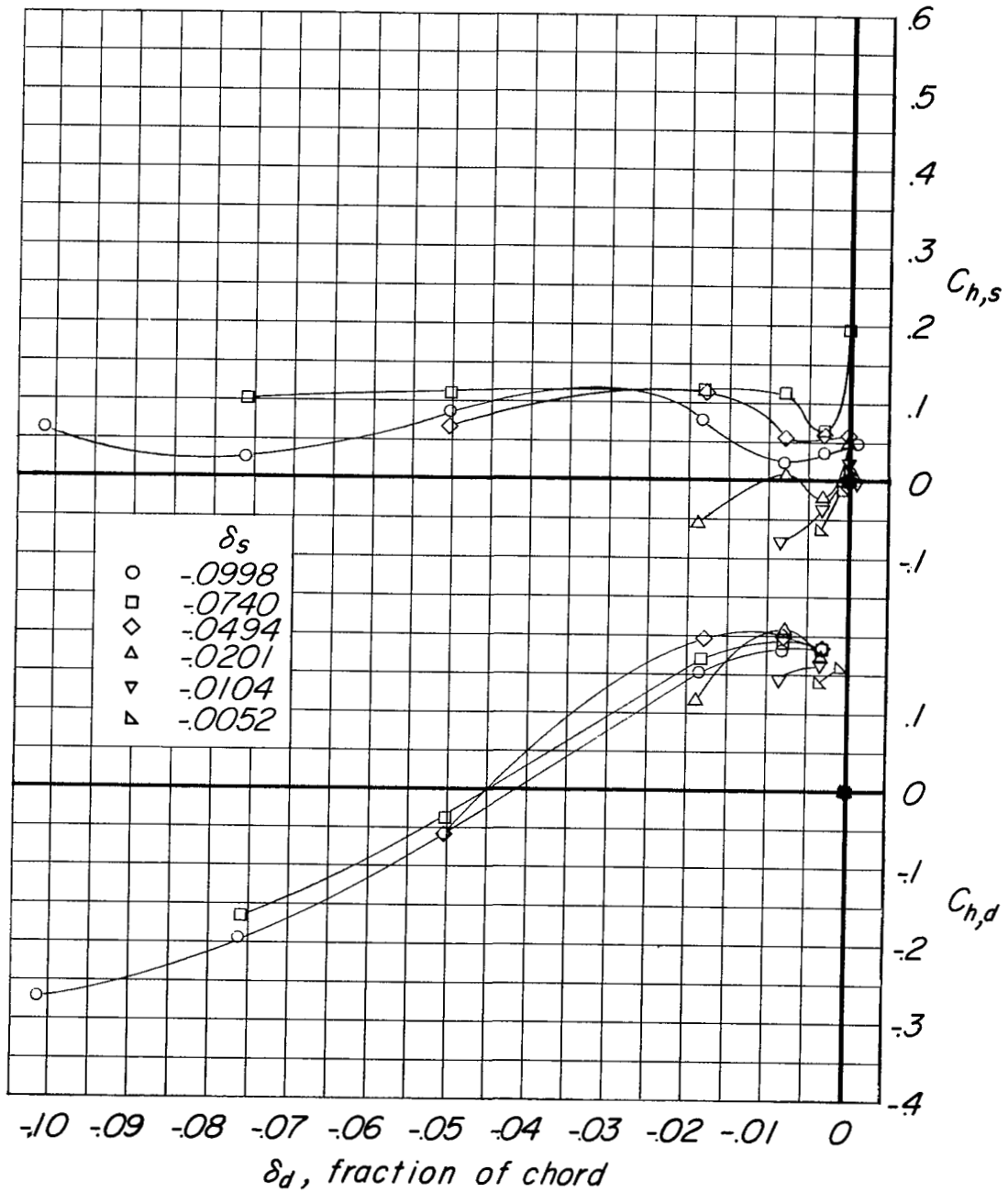
(d) $\alpha = 8^\circ$.

Figure 4.- Continued.



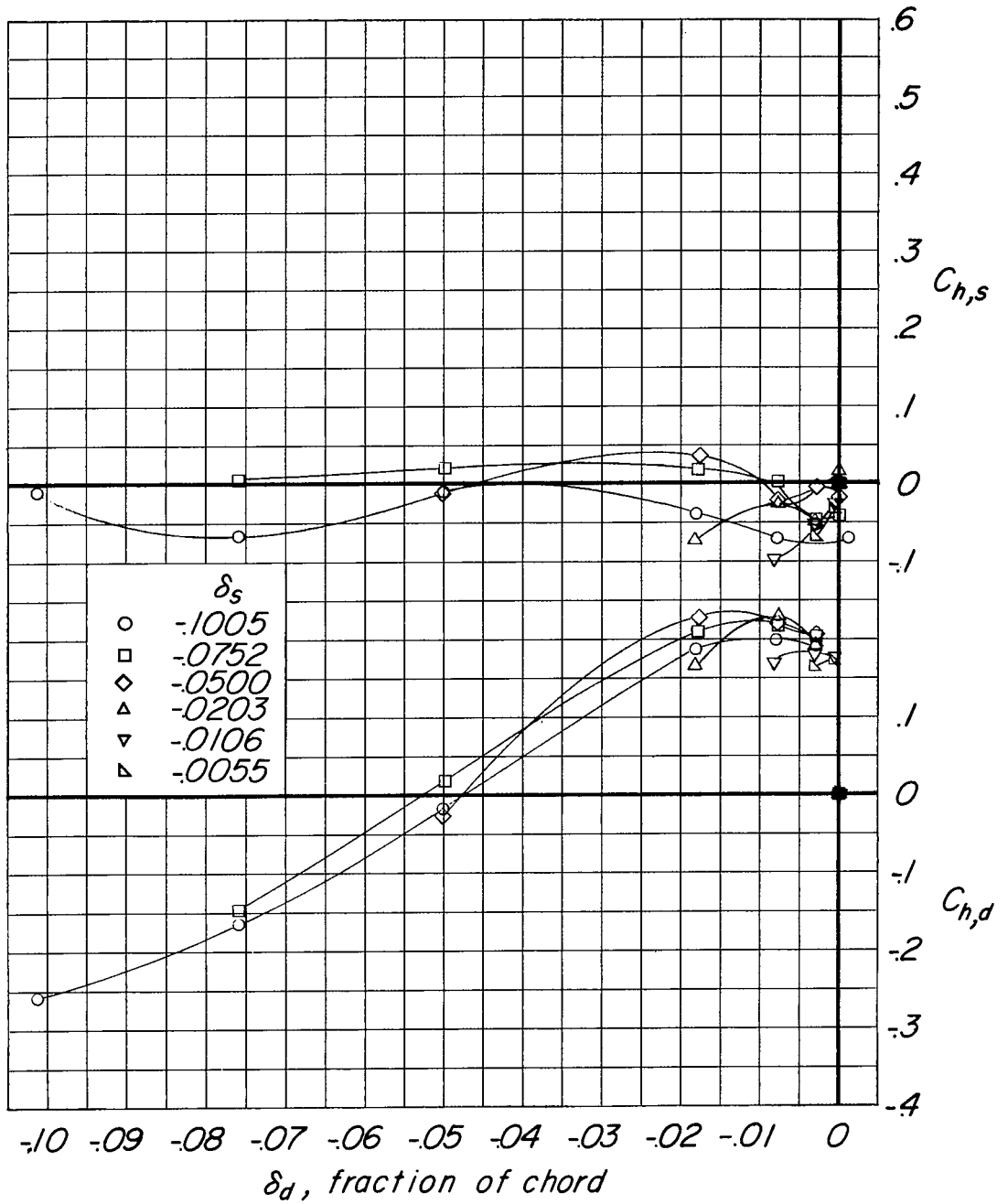
(e) $\alpha = 12^\circ$.

Figure 4.- Continued.



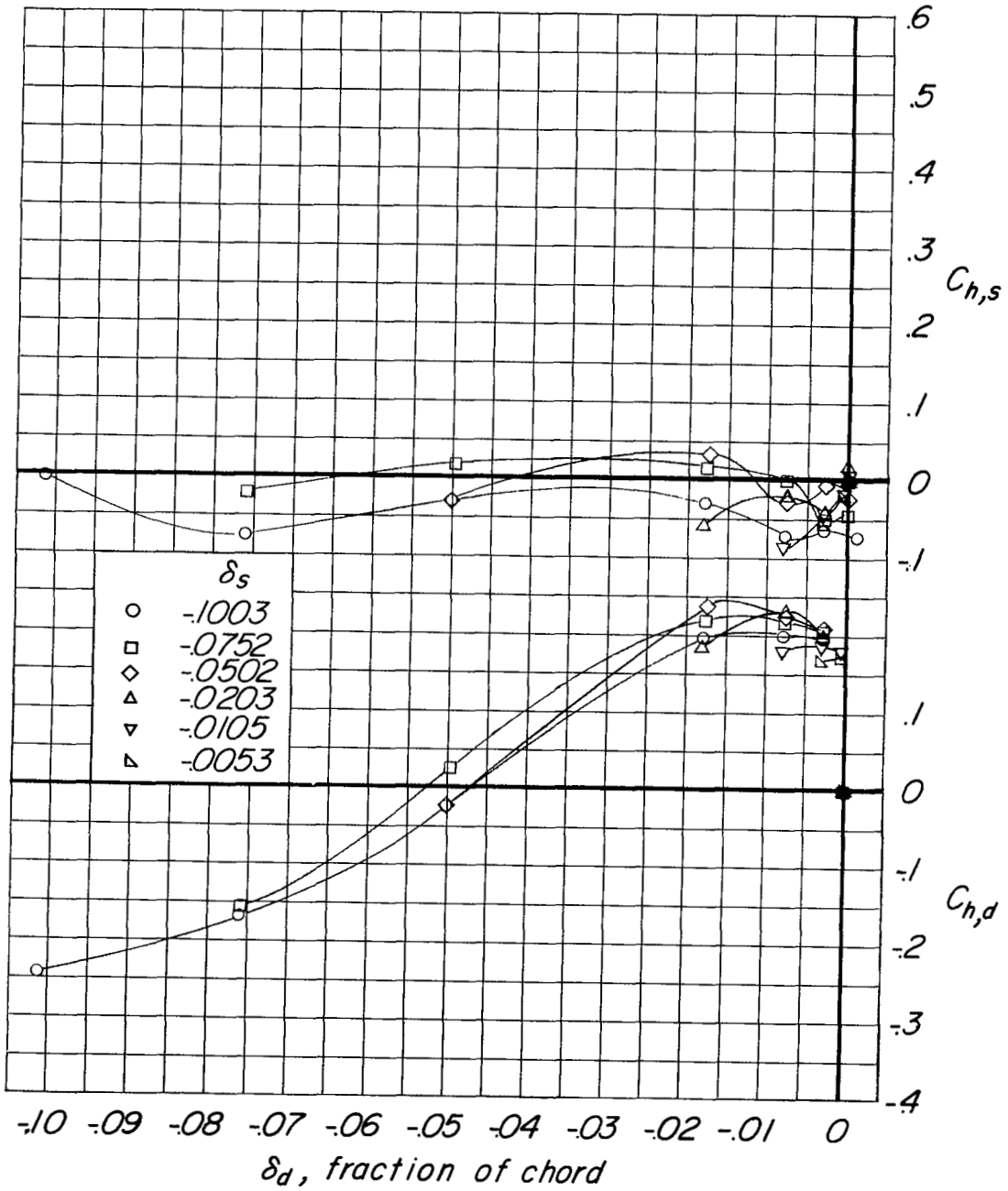
(f) $\alpha = 16^\circ$.

Figure 4.- Continued.



(g) $\alpha = 20^\circ$.

Figure 4.- Continued.



(h) $\alpha = 24^\circ$.

Figure 4.- Concluded.

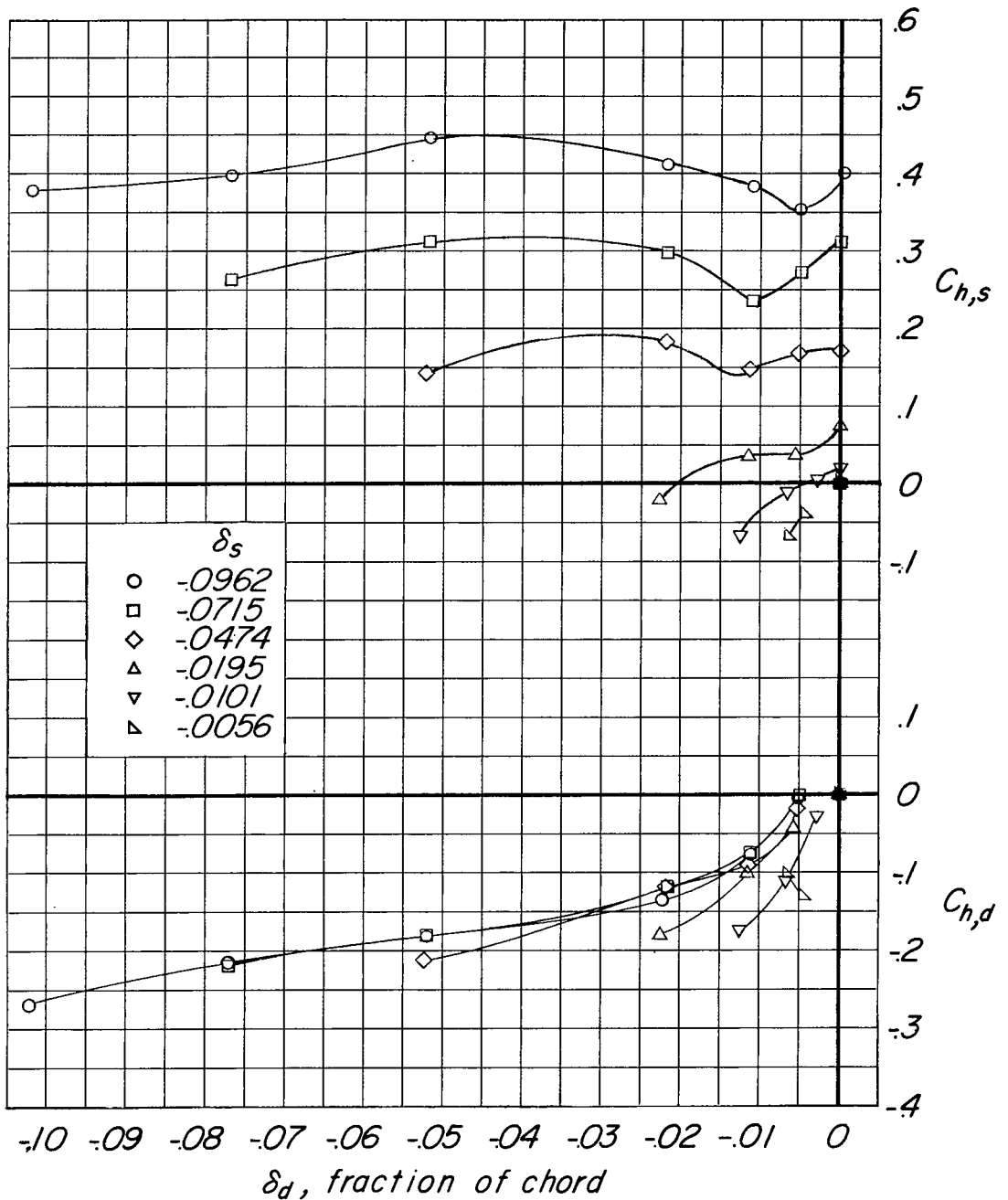
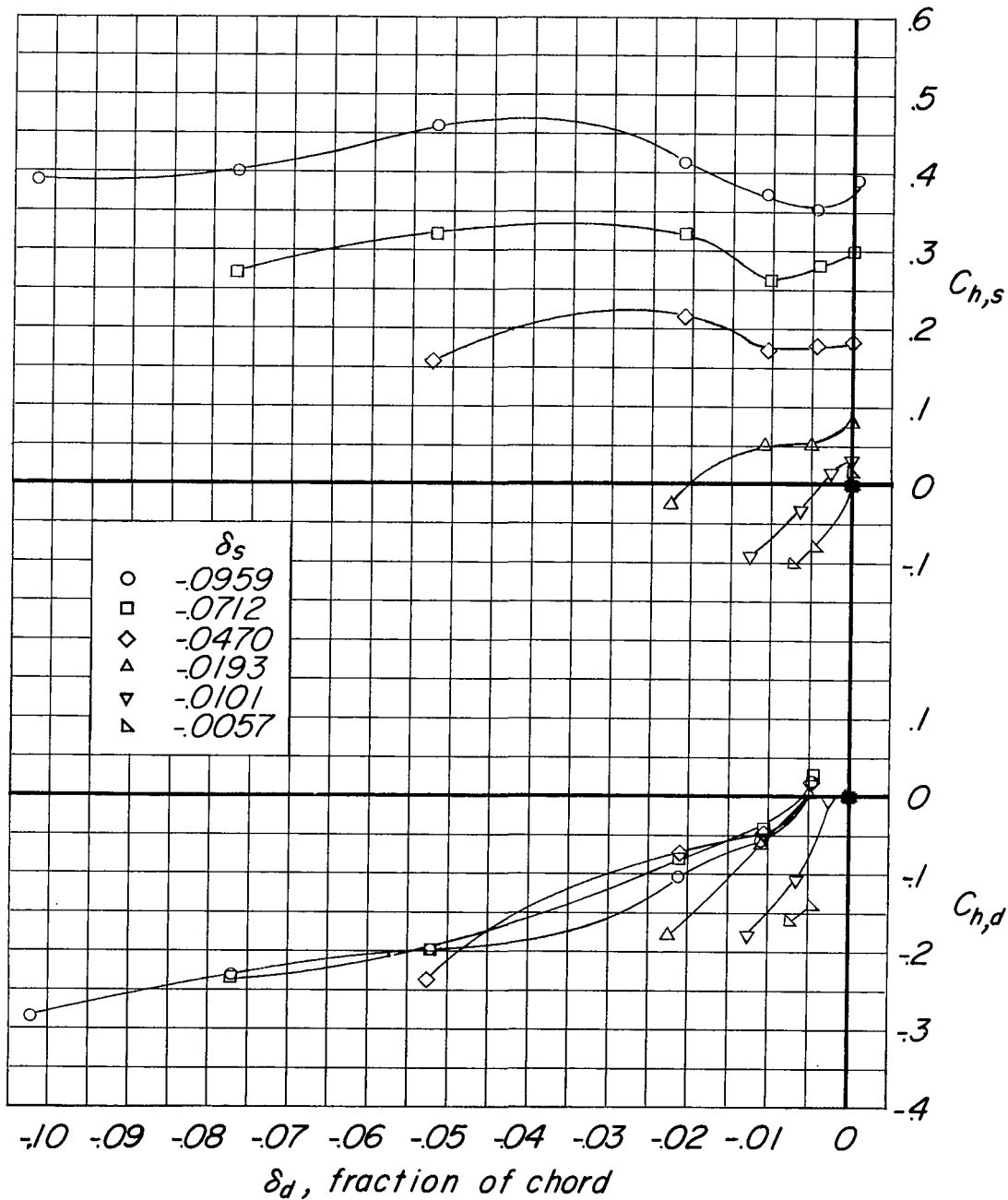
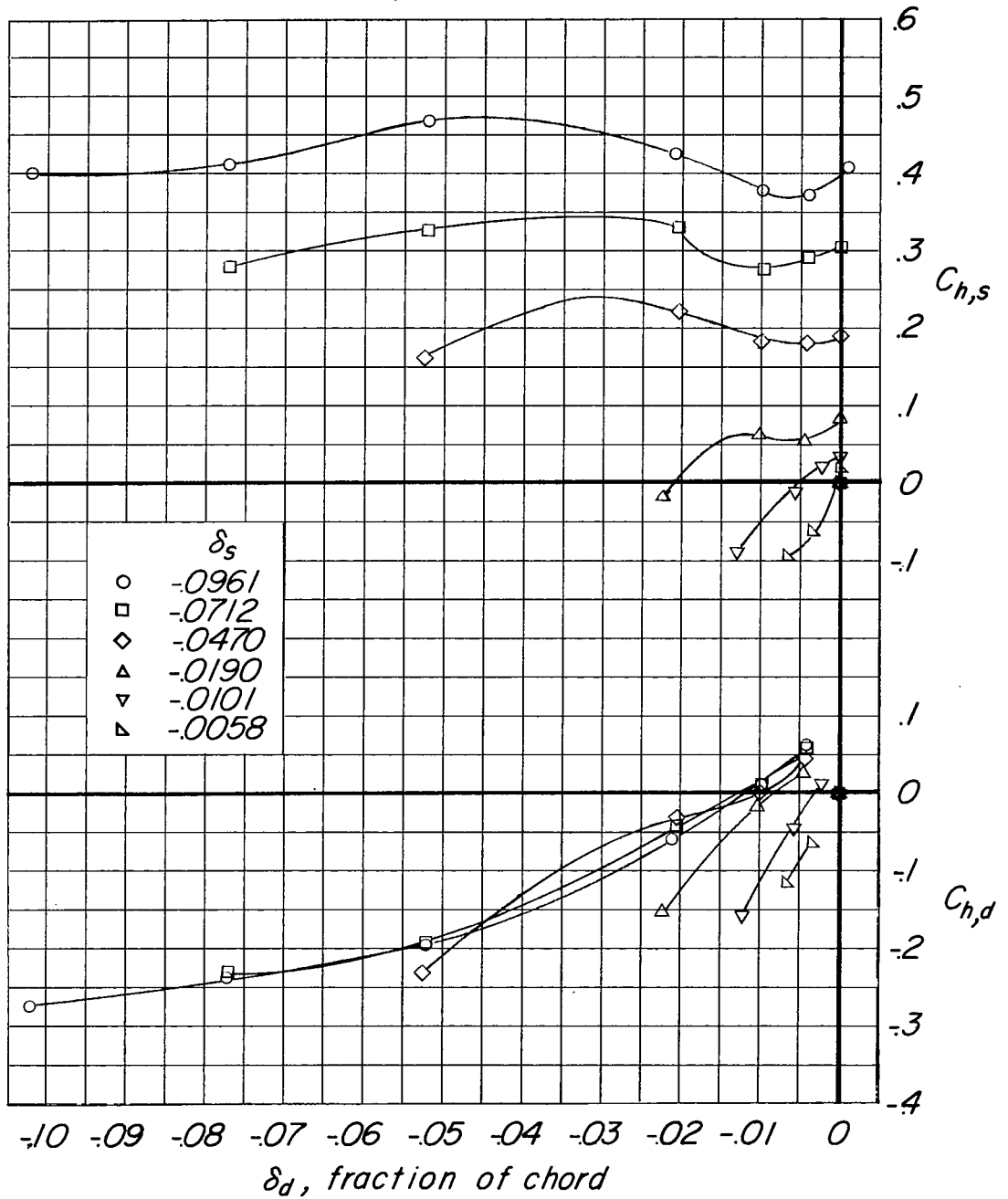
(a) $\alpha = -4^\circ$.

Figure 5.- Variation of hinge-moment characteristics with deflector projection of the spoiler and deflector for a 35° sweptback wing at a Mach number of 0.80.



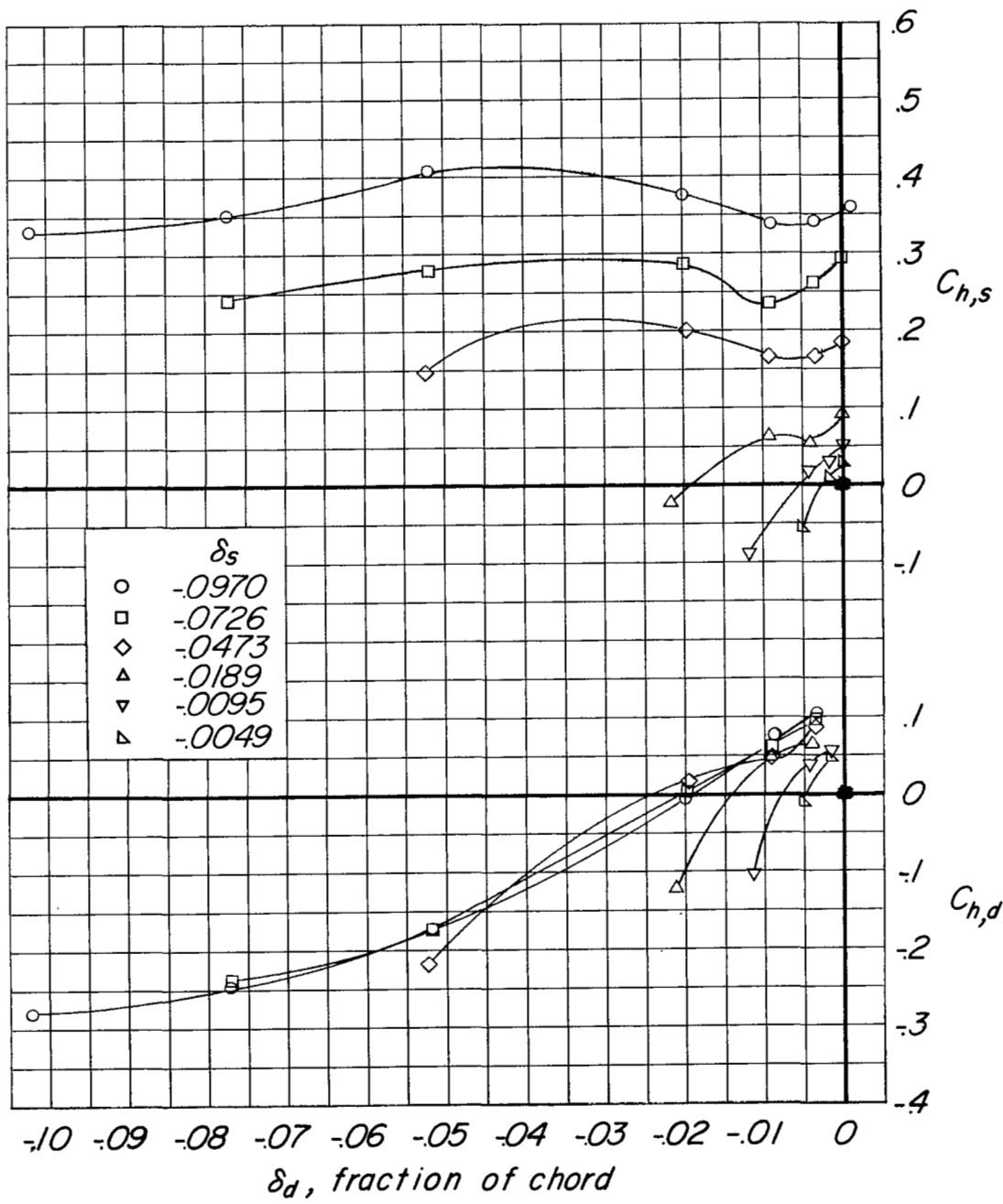
(b) $\alpha = 0^\circ$.

Figure 5.- Continued.



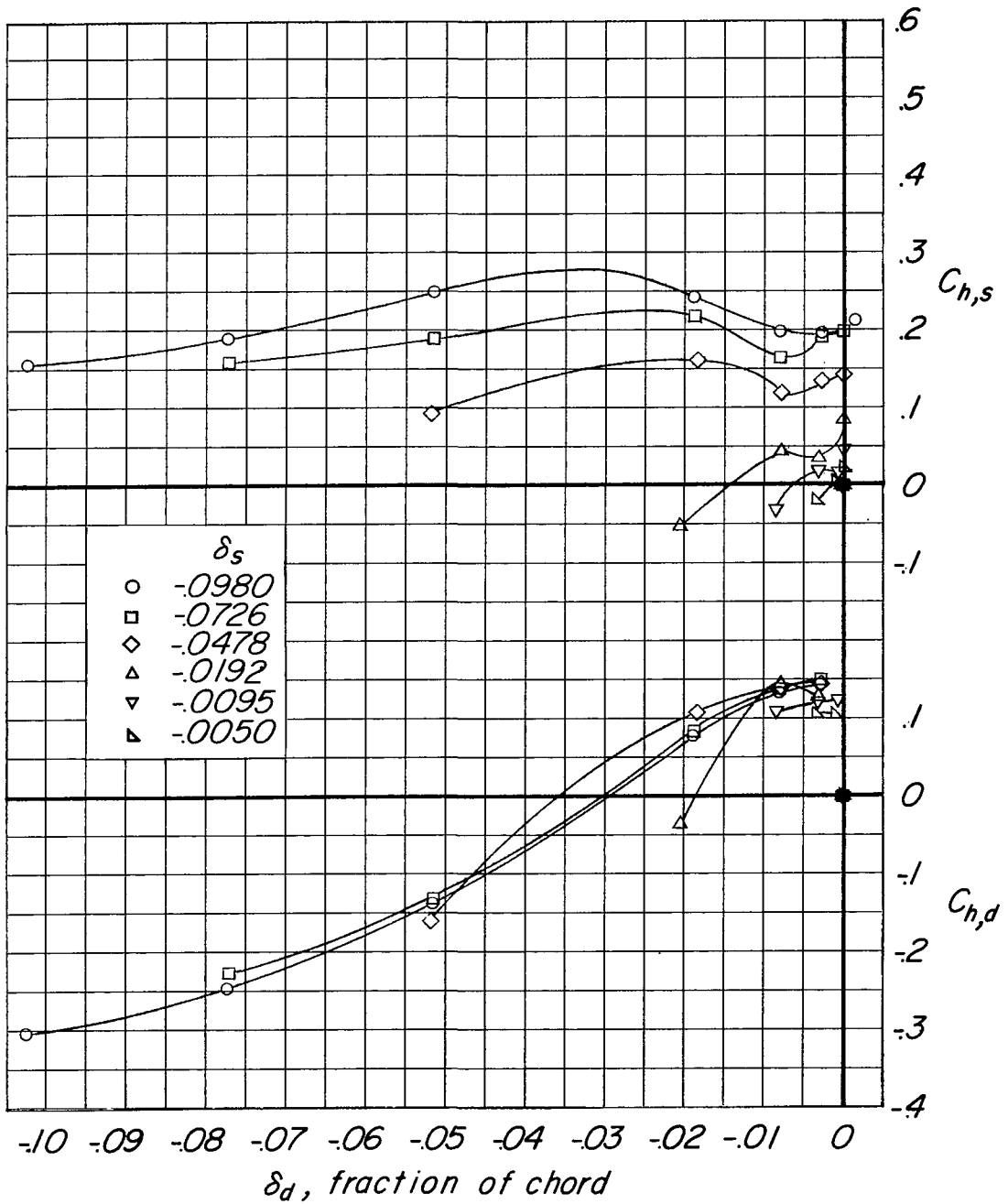
(c) $\alpha = 4^\circ$.

Figure 5.- Continued.



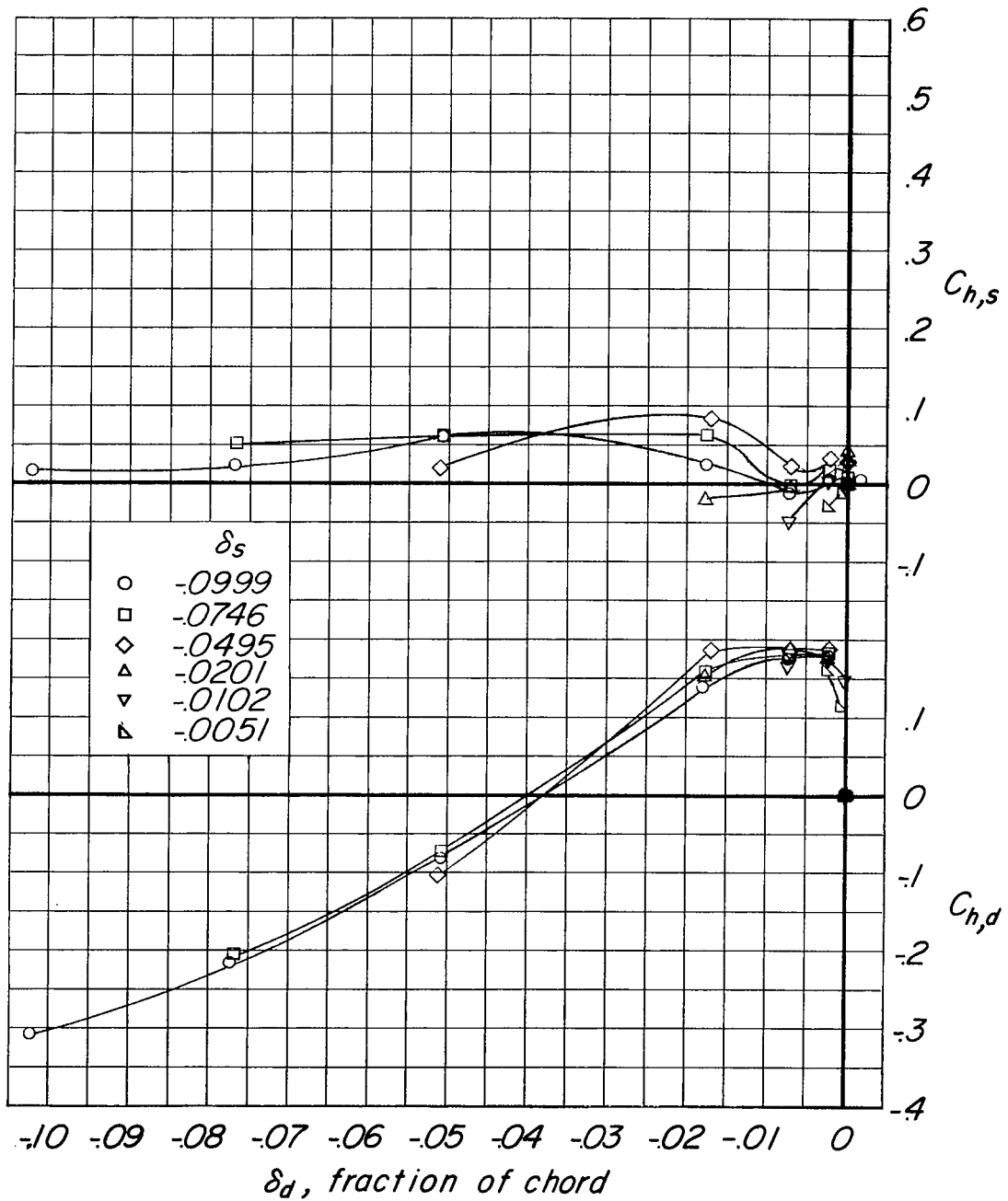
(d) $\alpha = 8^\circ$.

Figure 5.- Continued.



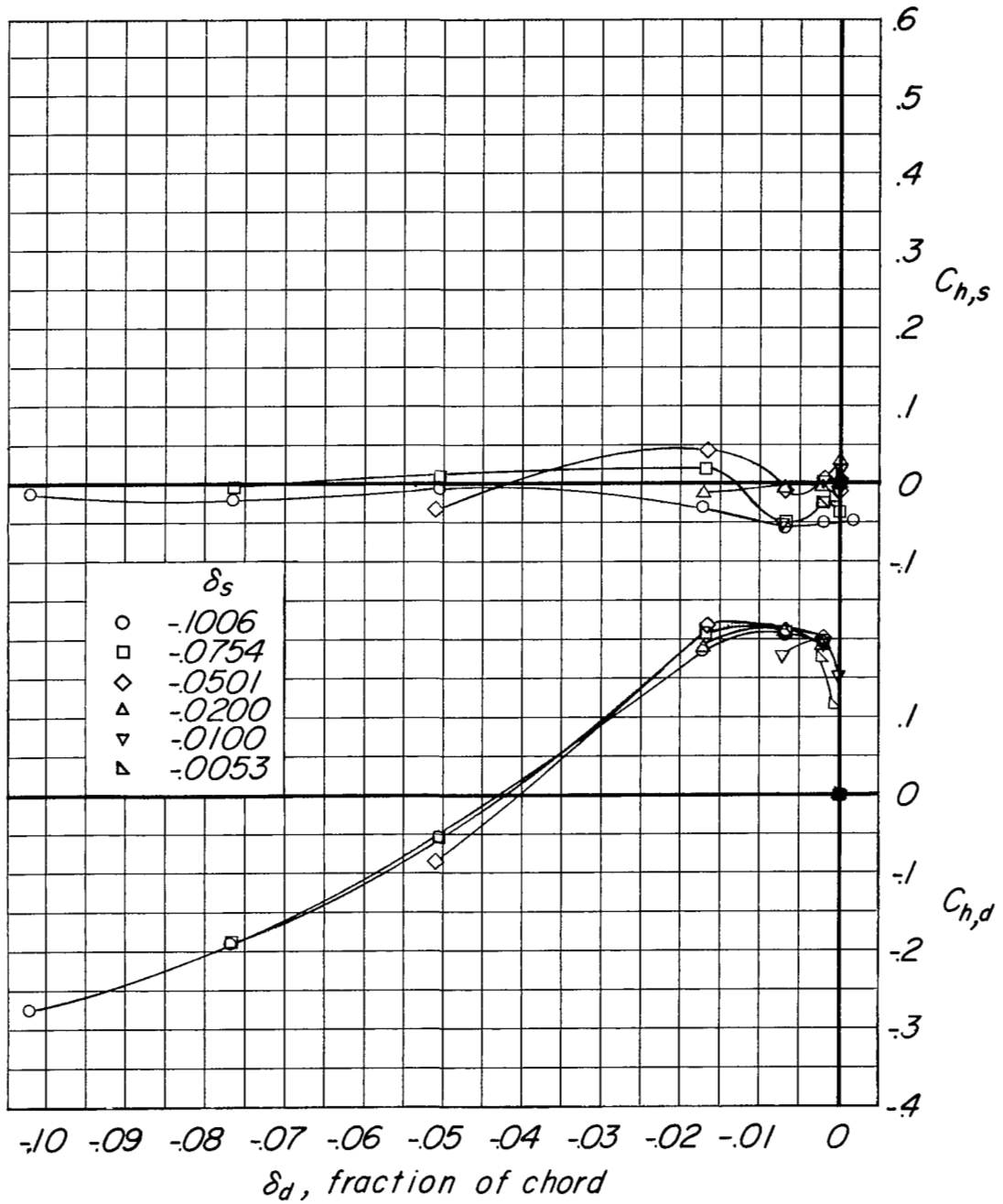
(e) $\alpha = 12^\circ$.

Figure 5.- Continued.



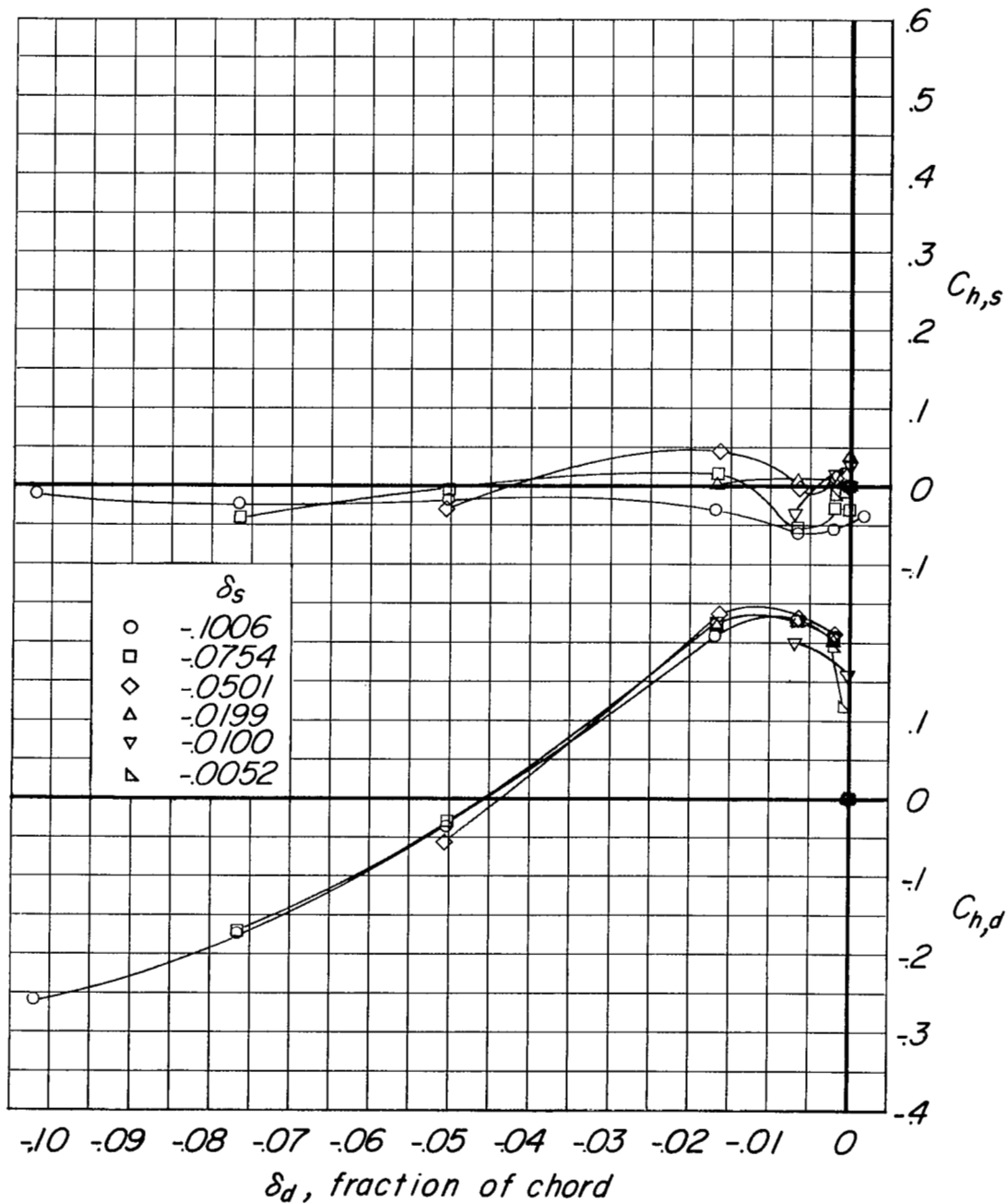
(f) $\alpha = 16^\circ$.

Figure 5.- Continued.



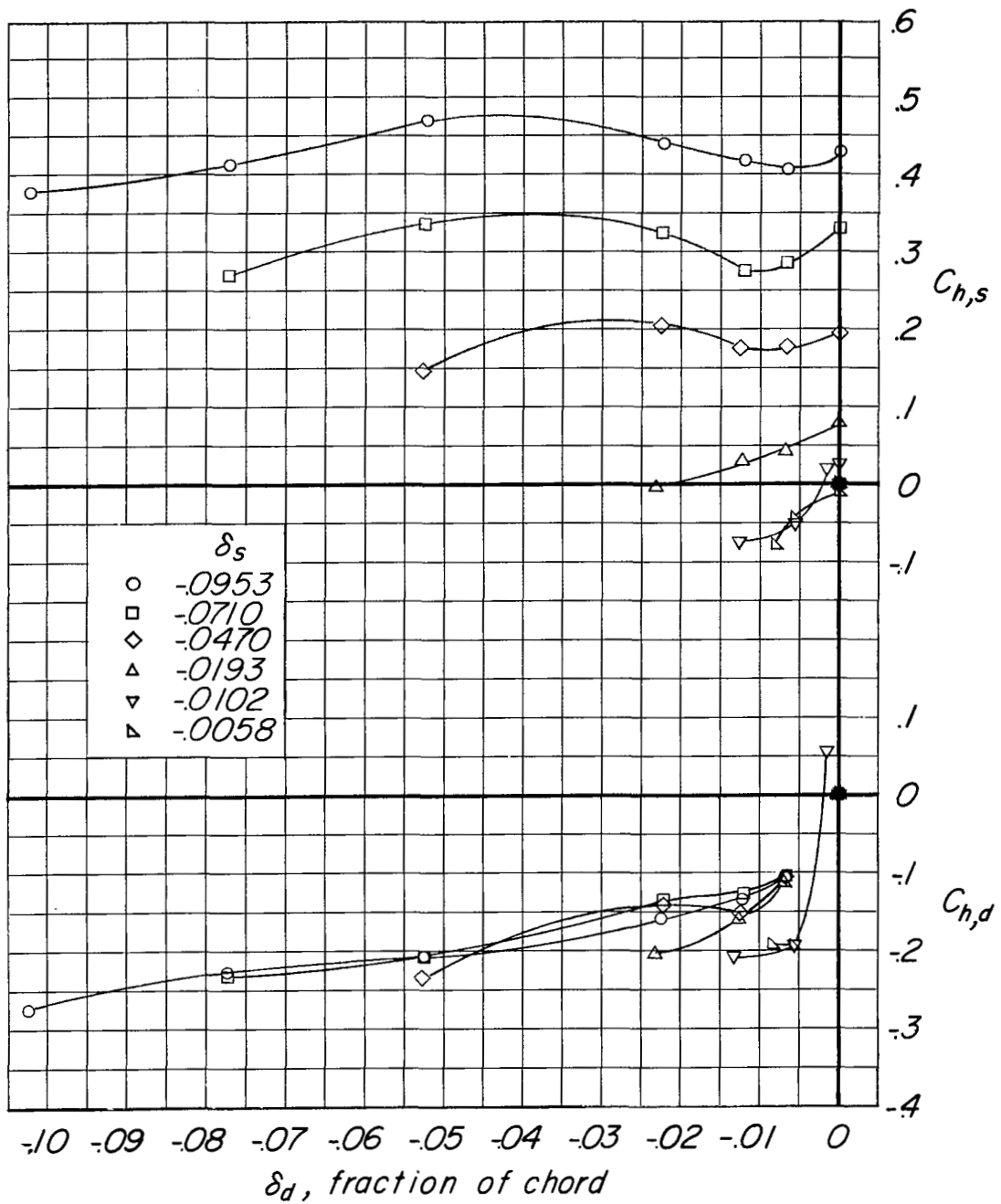
(g) $\alpha = 20^\circ$.

Figure 5.- Continued.



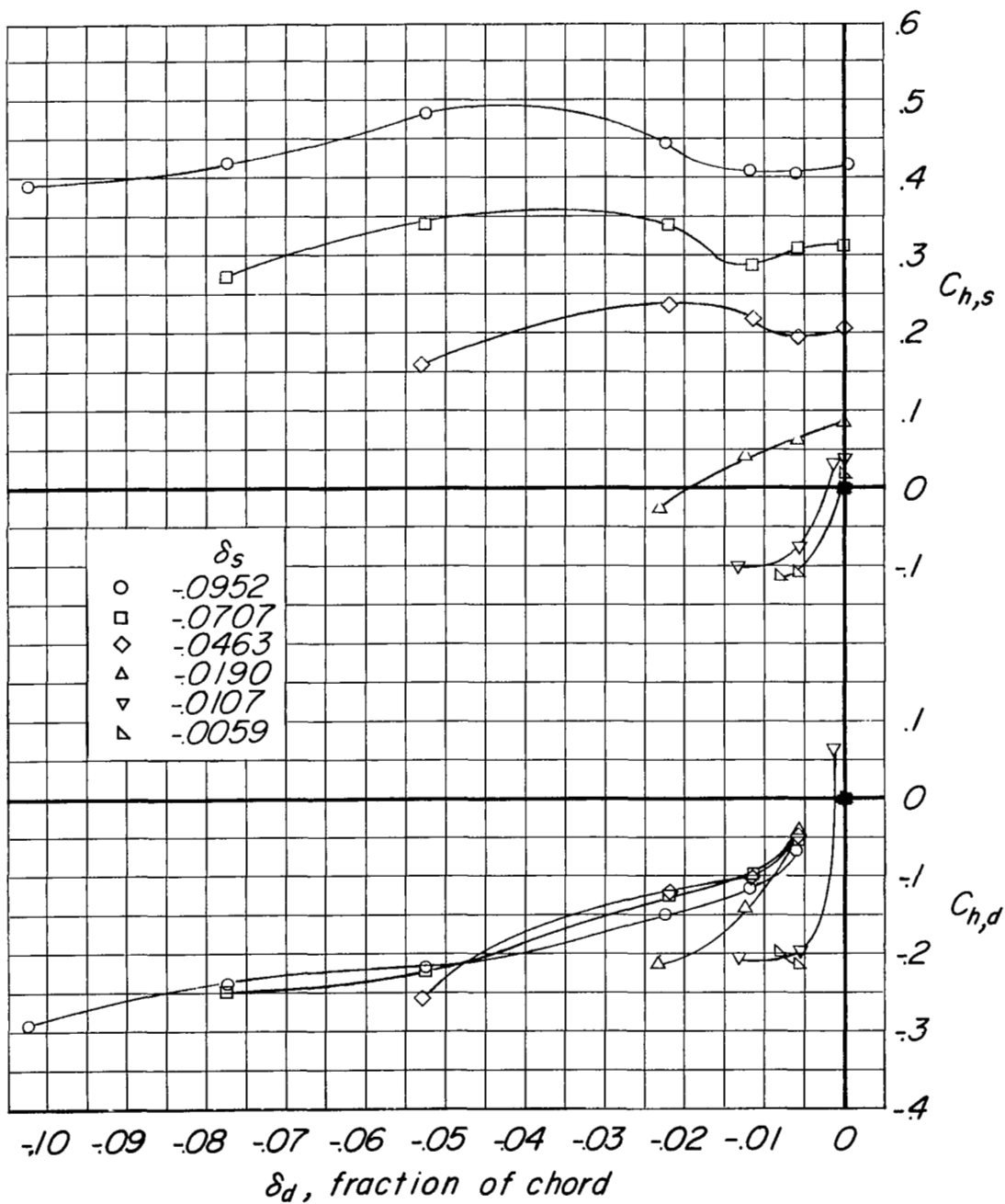
(h) $\alpha = 24^\circ$.

Figure 5.- Concluded.



(a) $\alpha = -4^\circ$.

Figure 6.- Variation of hinge-moment characteristics with deflector projection of the spoiler and deflector for a 35° sweptback wing at a Mach number of 0.85.



(b) $\alpha = 0^\circ$.

Figure 6.- Continued.

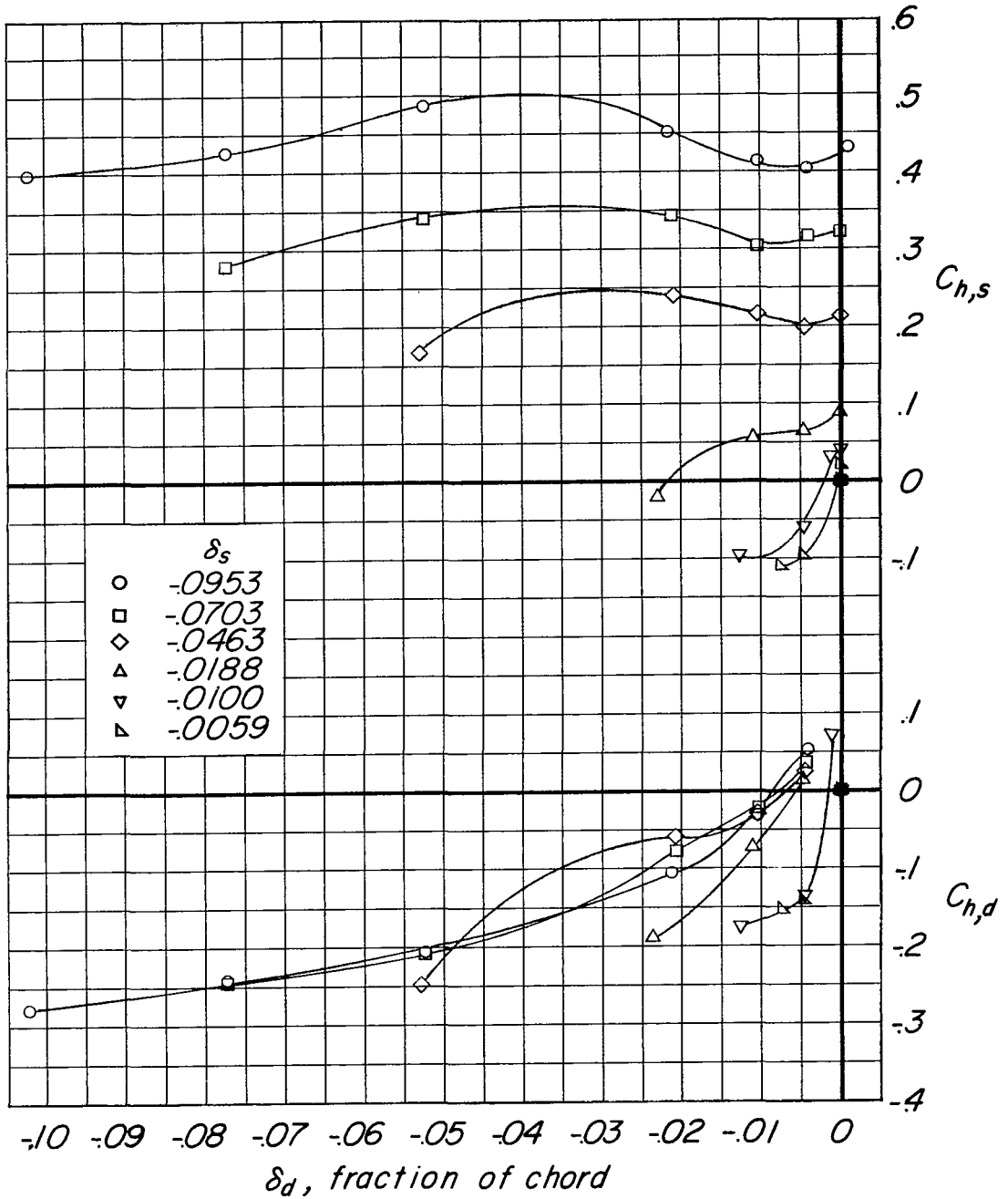
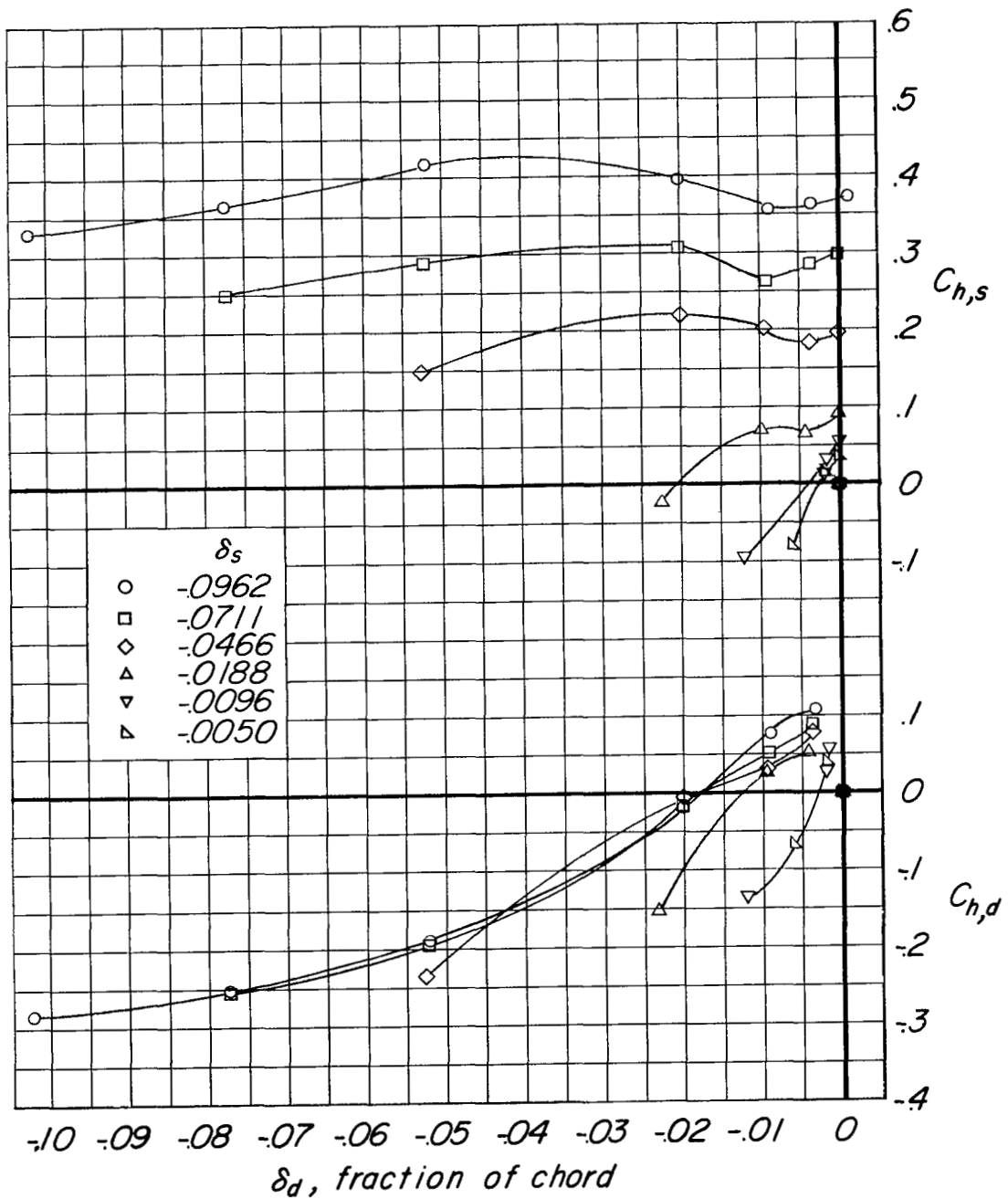
(c) $\alpha = 4^\circ$.

Figure 6.- Continued.



(a) $\alpha = 8^\circ$.

Figure 6.- Continued.

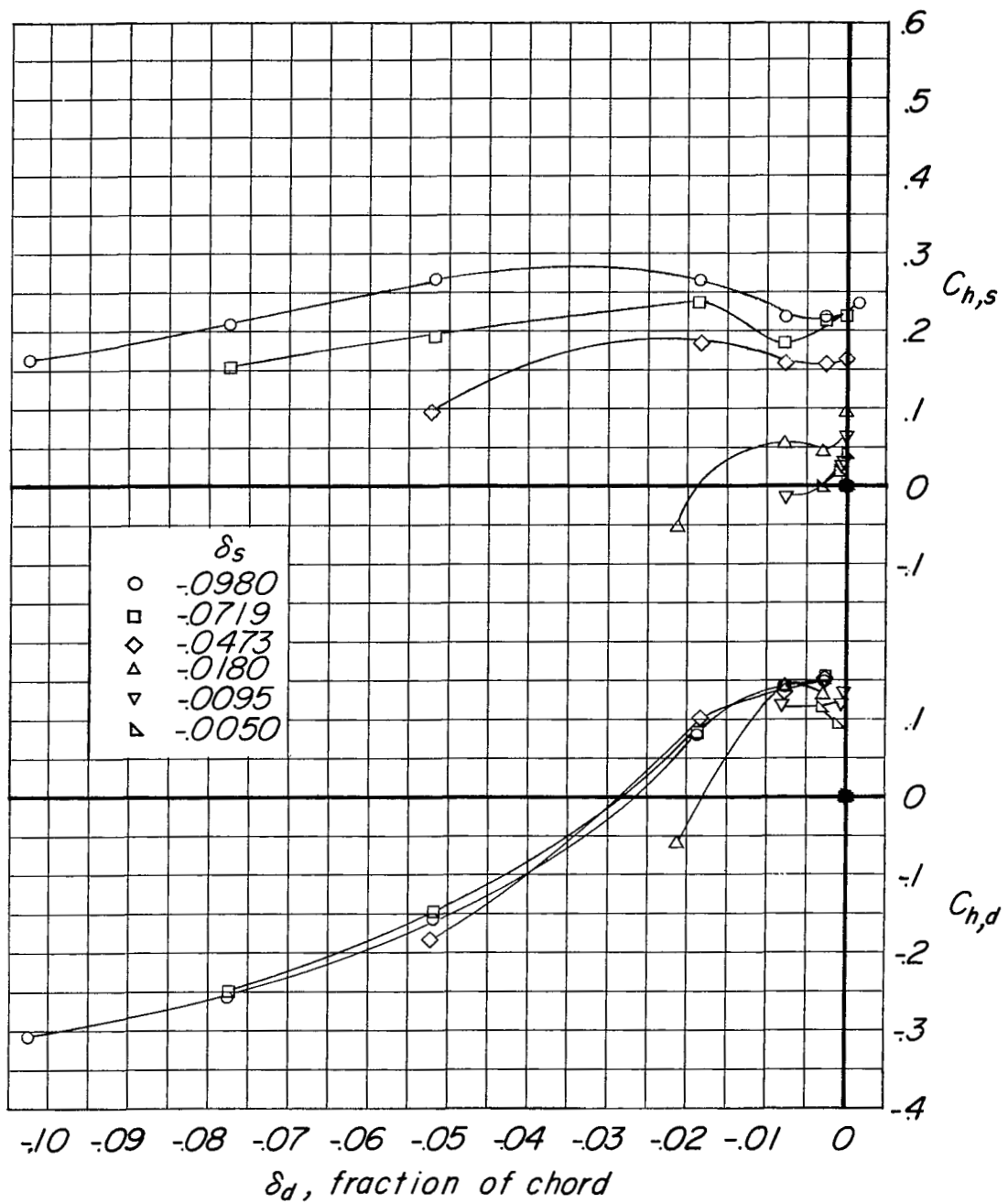
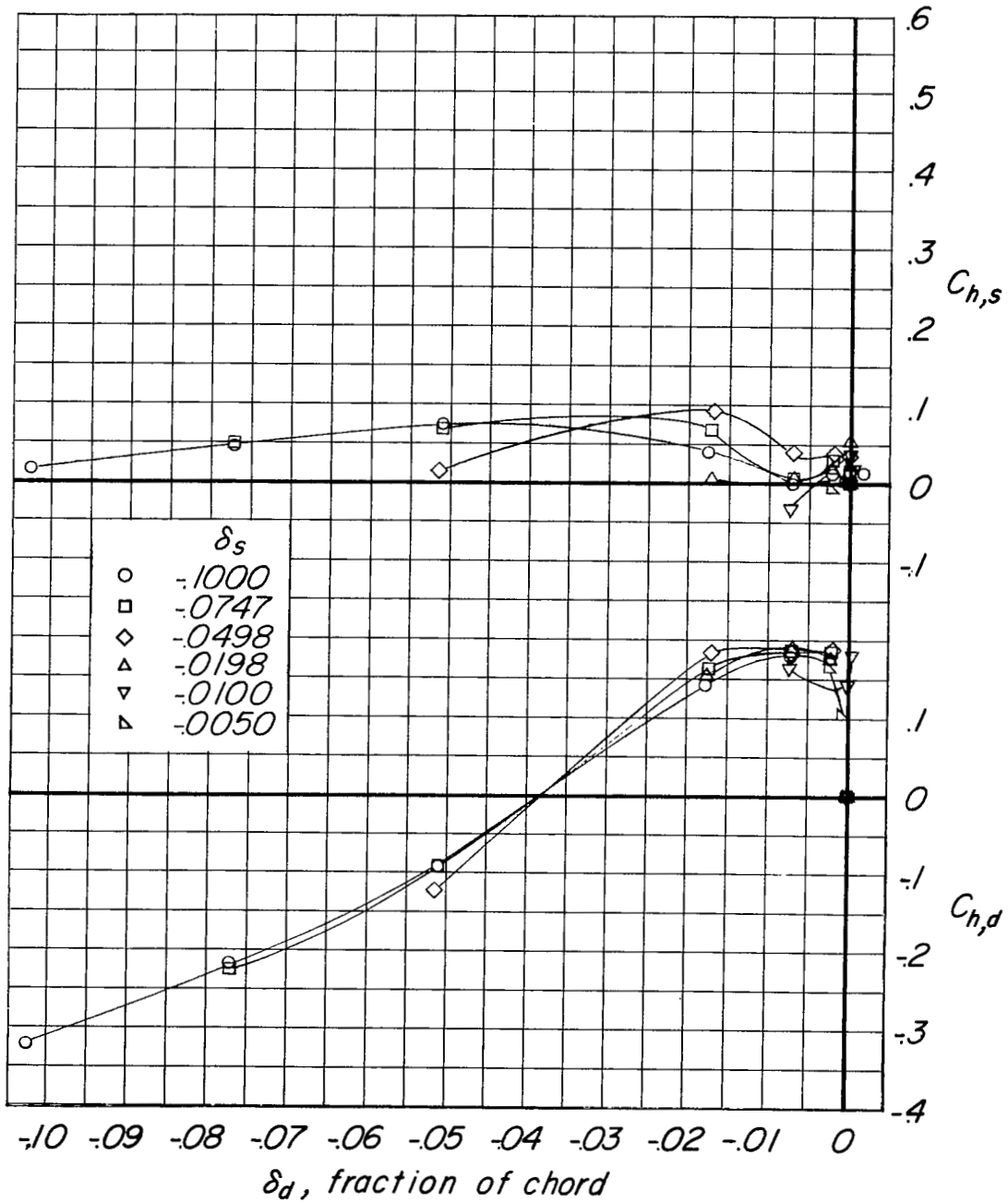
(e) $\alpha = 12^\circ$.

Figure 6.- Continued.



(f) $\alpha = 16^\circ$.

Figure 6.- Concluded.

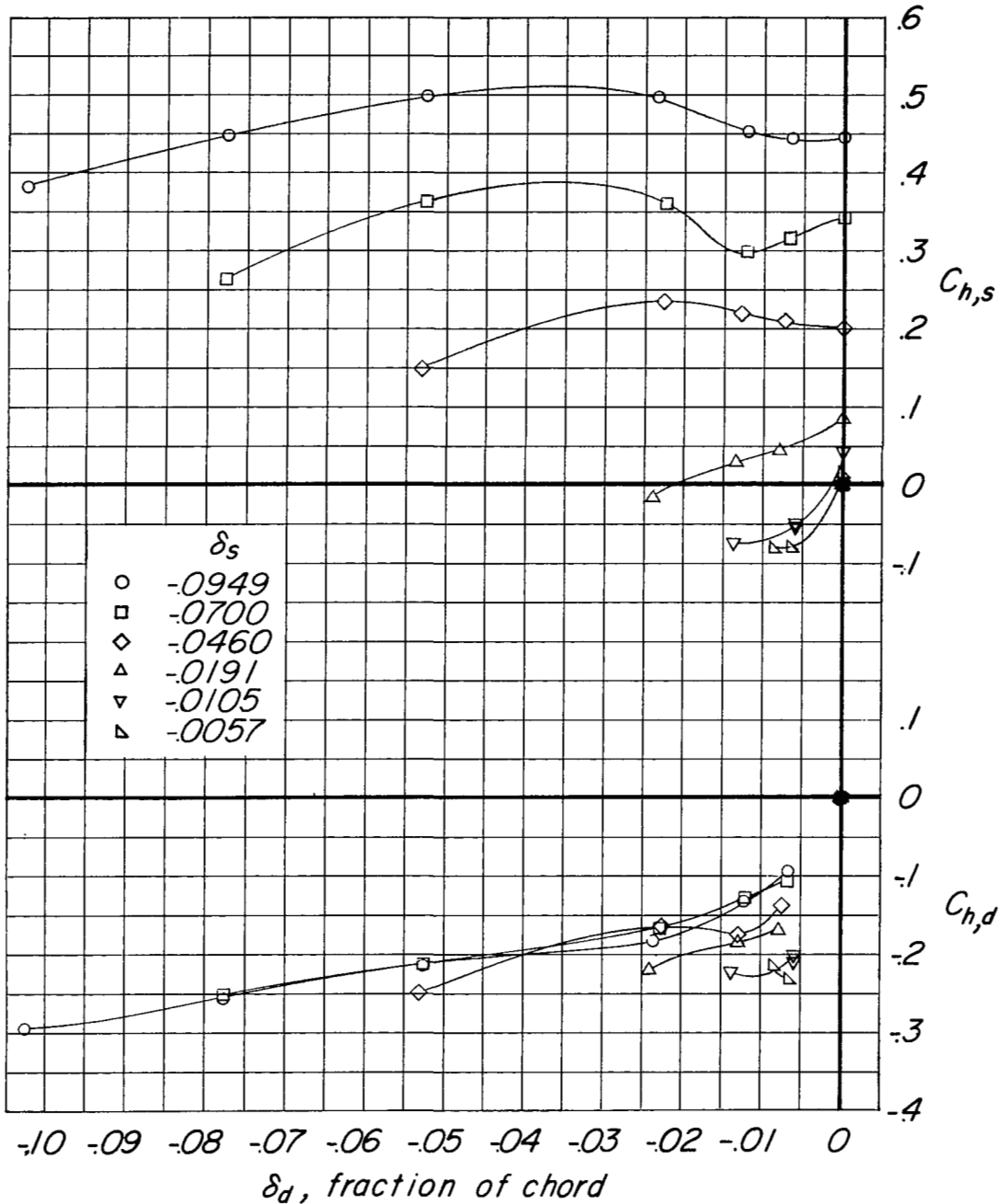
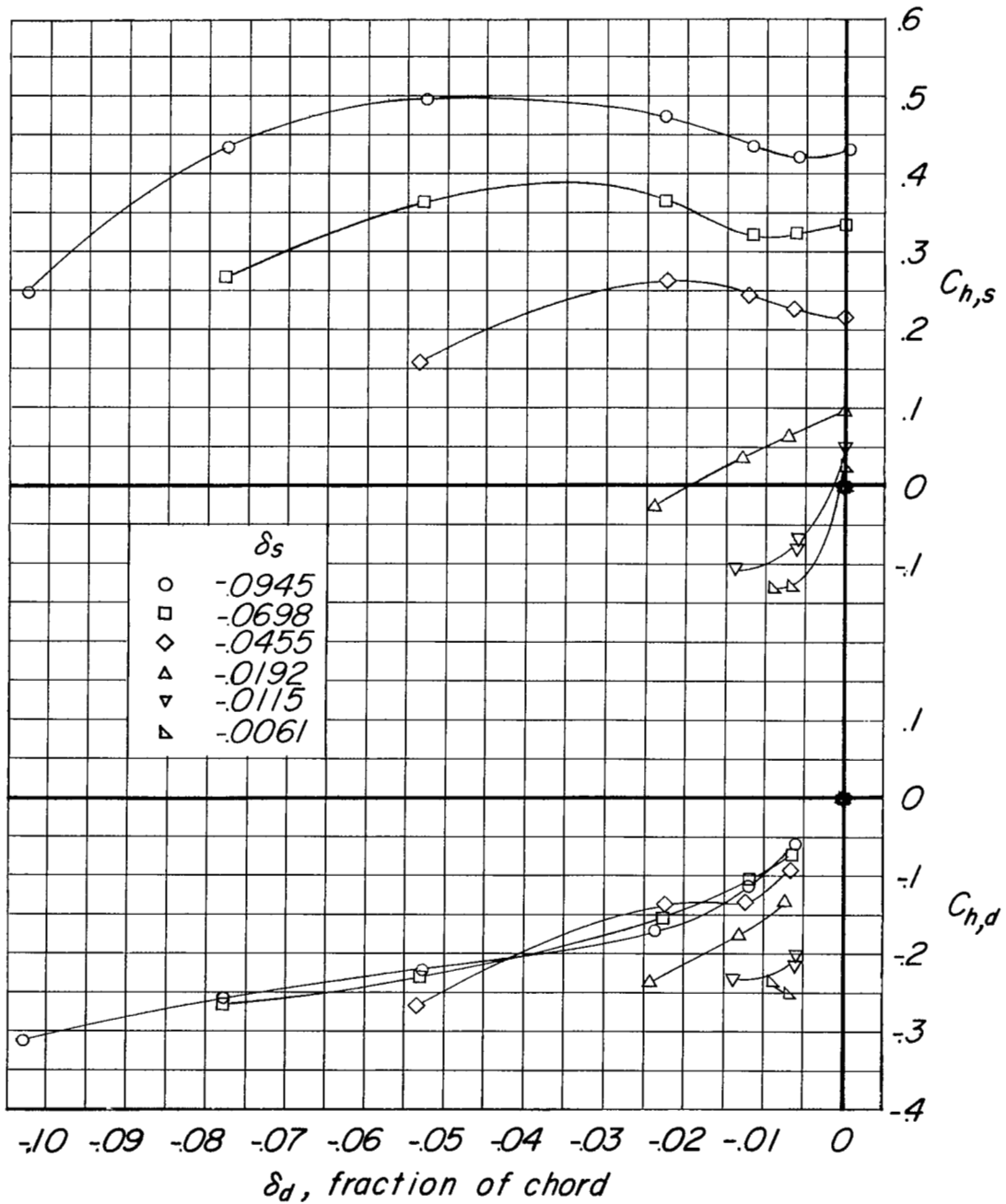
(a) $\alpha = -4^\circ$.

Figure 7.- Variation of hinge-moment characteristics with deflector projection of the spoiler and deflector for a 35° sweptback wing at a Mach number of 0.90.



(b) $\alpha = 0^\circ$.

Figure 7.- Continued.

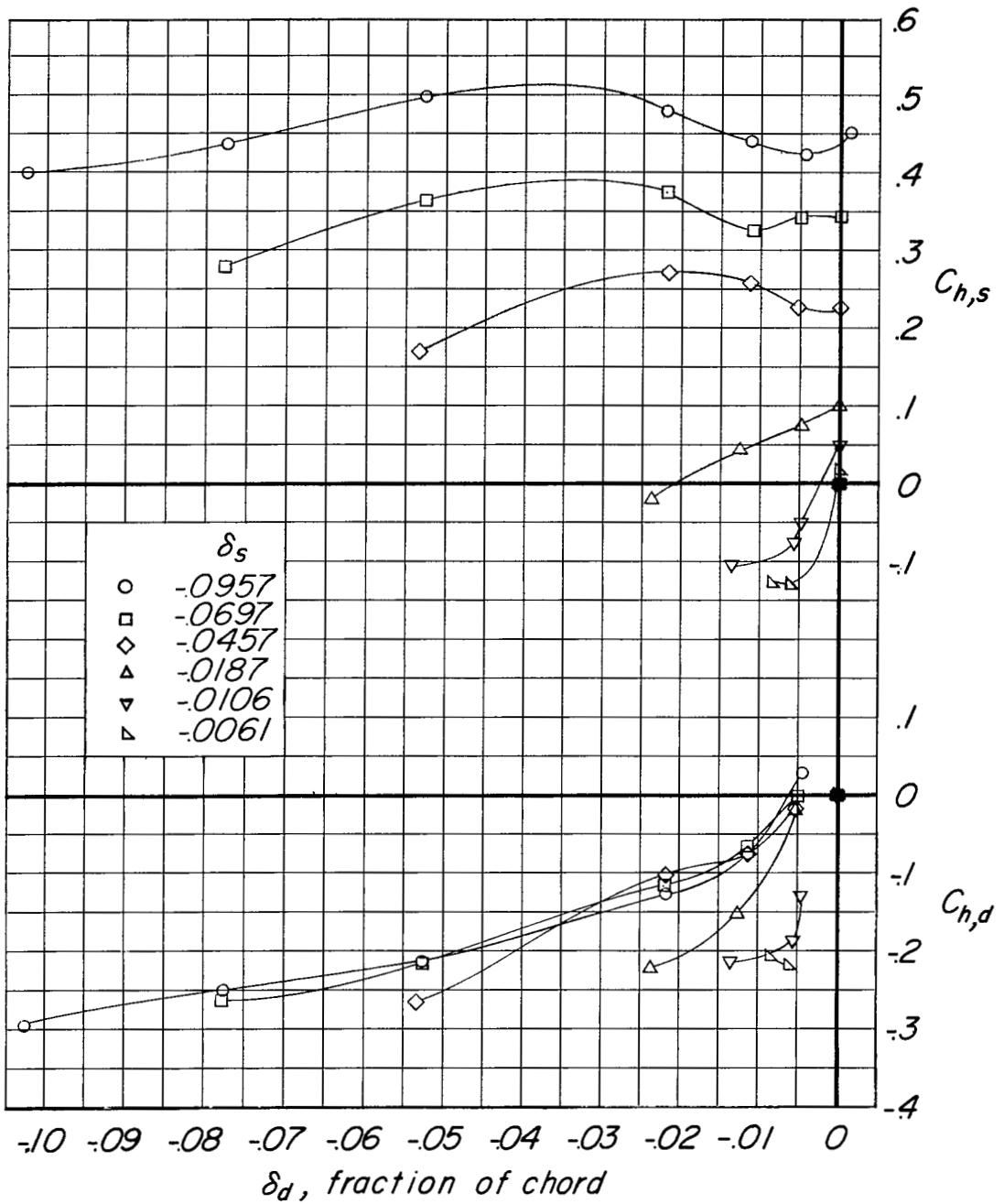
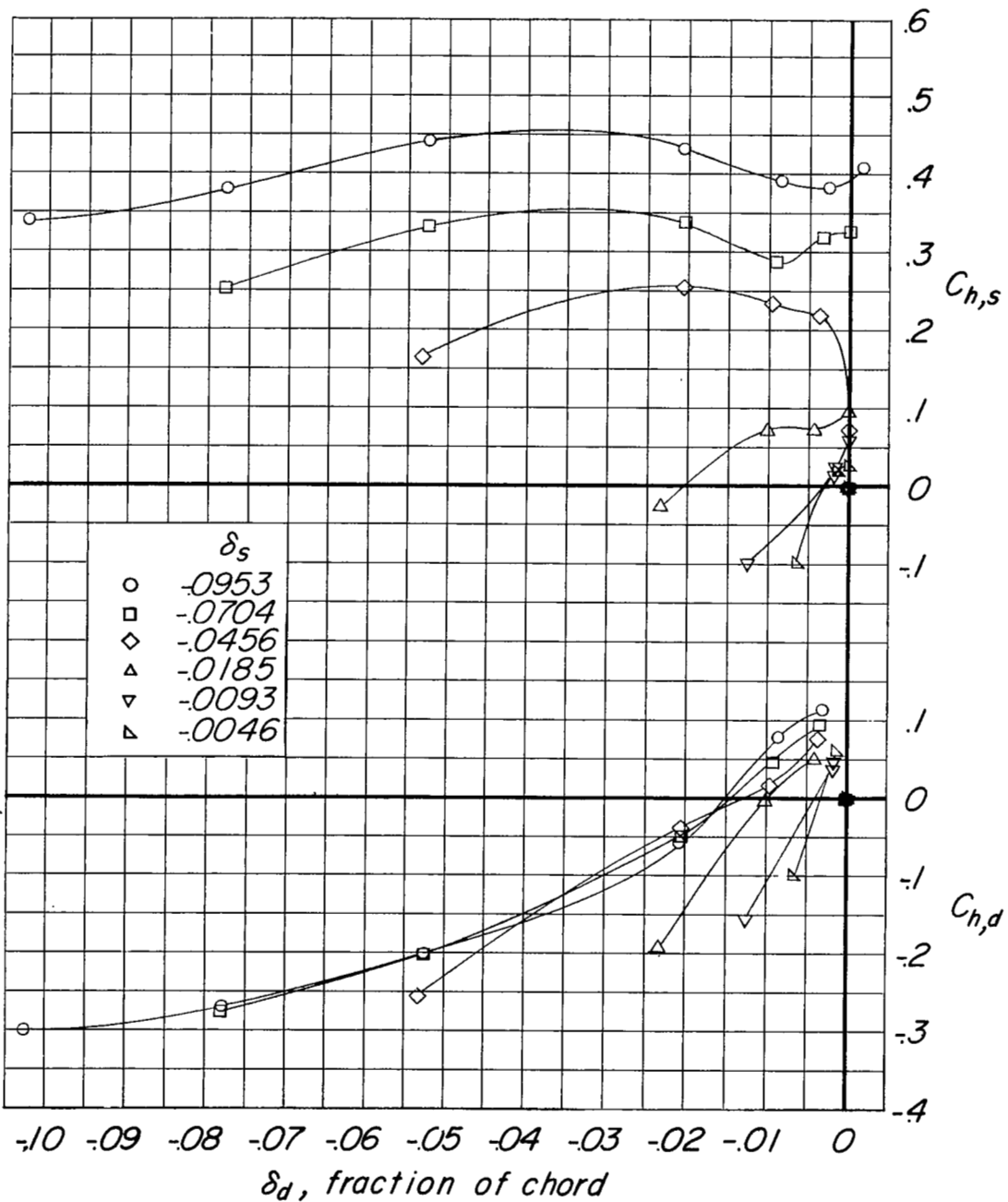
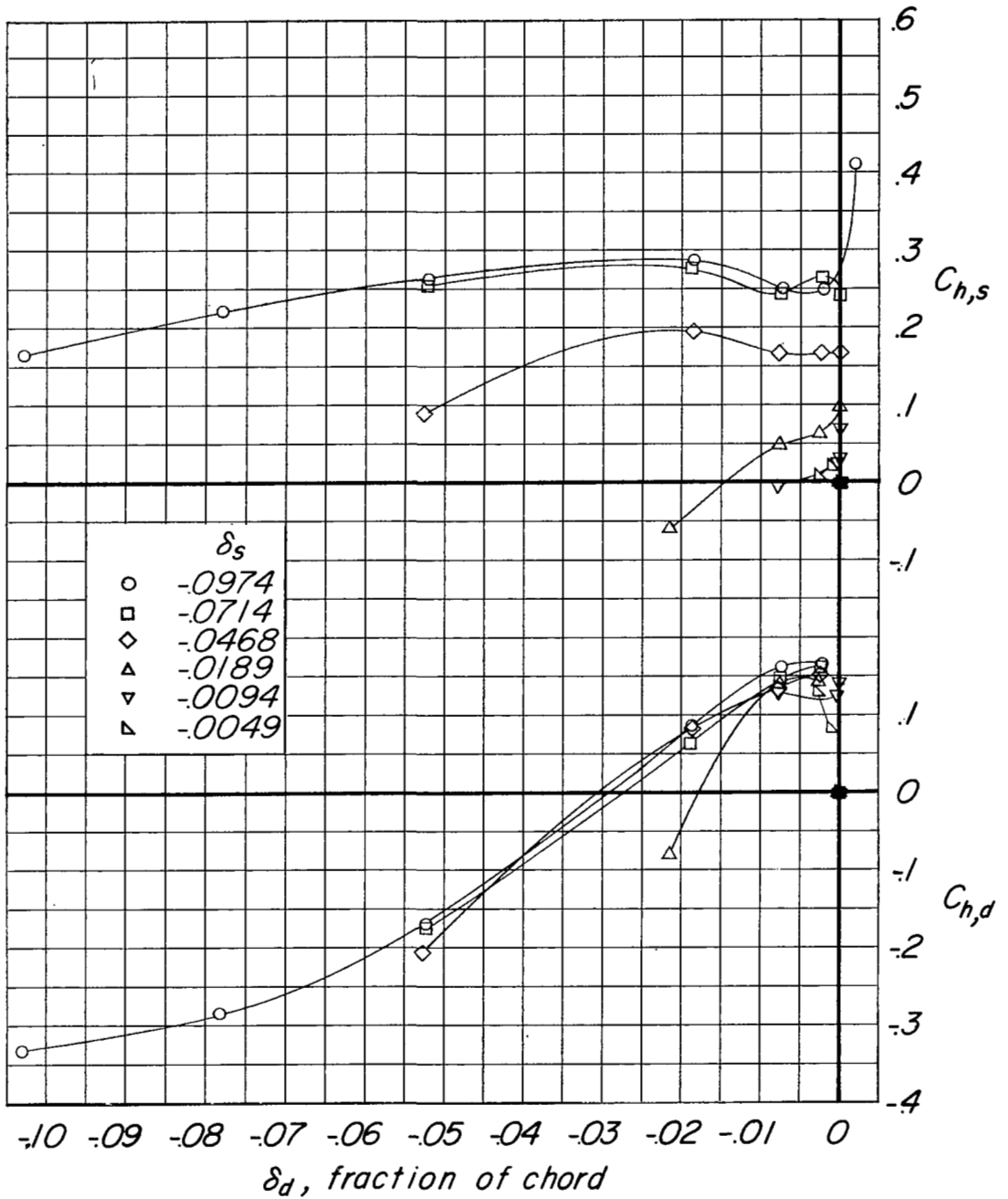
(c) $\alpha = 4^\circ$.

Figure 7.- Continued.



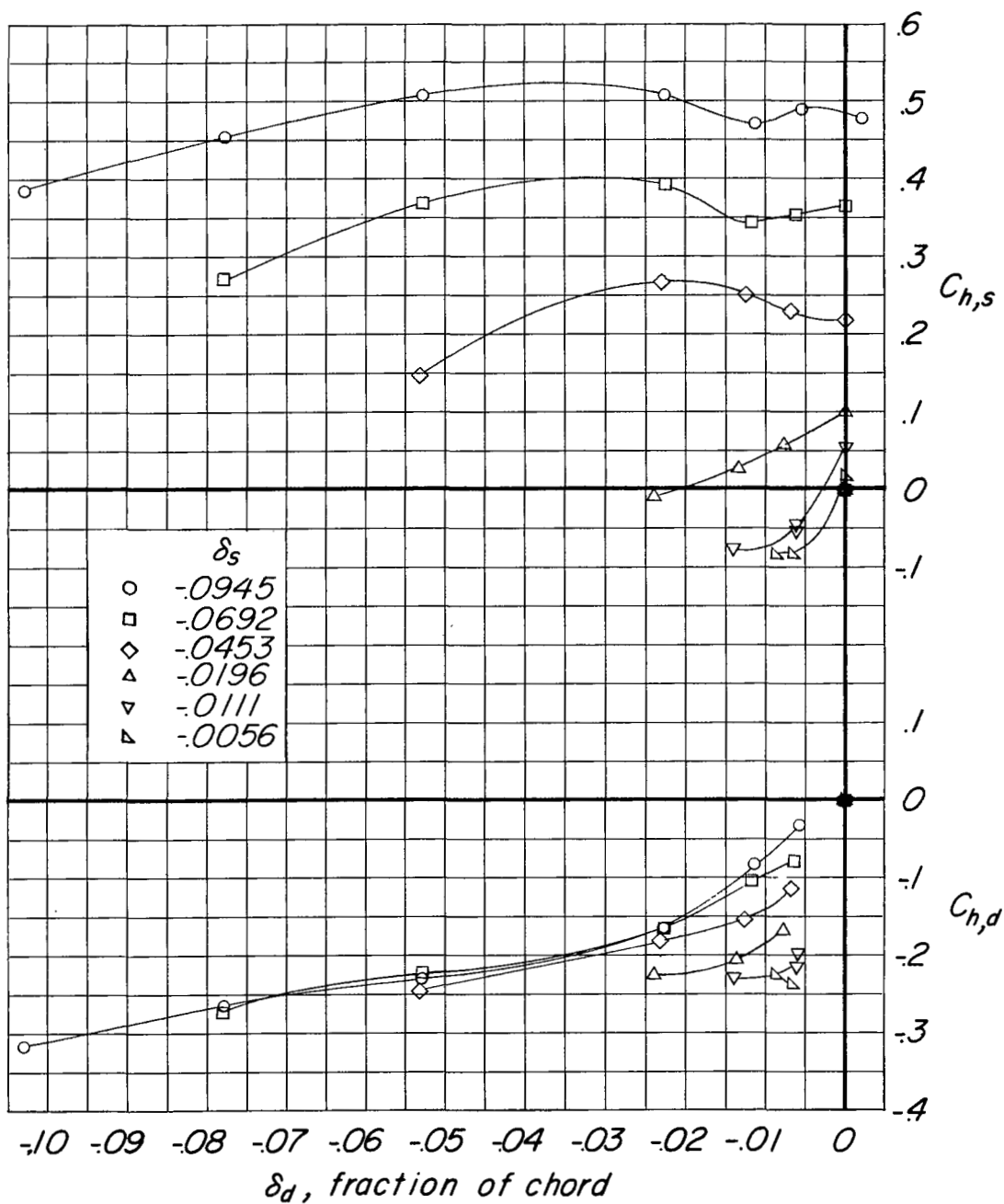
(d) $\alpha = 8^\circ$.

Figure 7.- Continued.



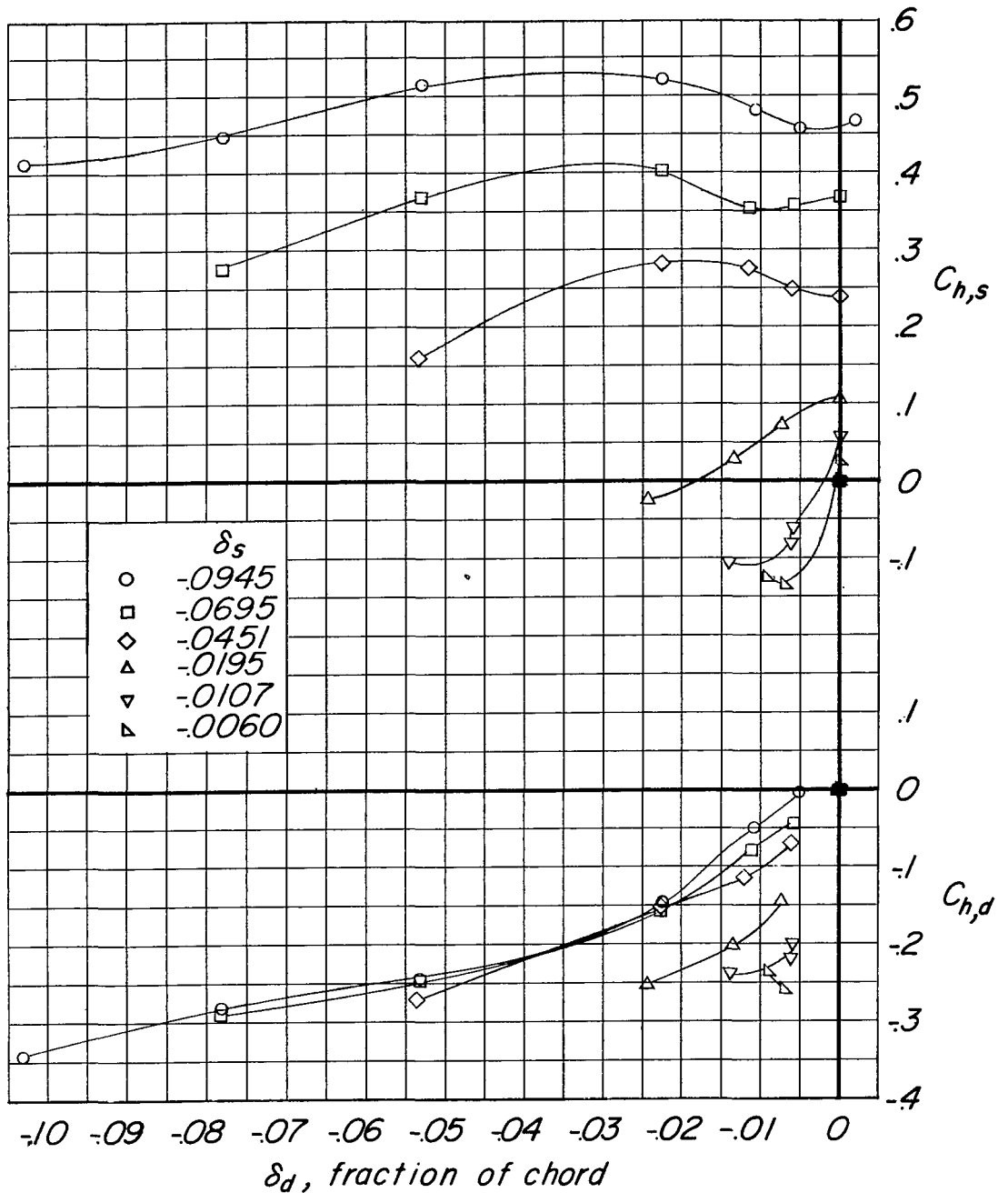
(e) $\alpha = 12^\circ$.

Figure 7.- Concluded.



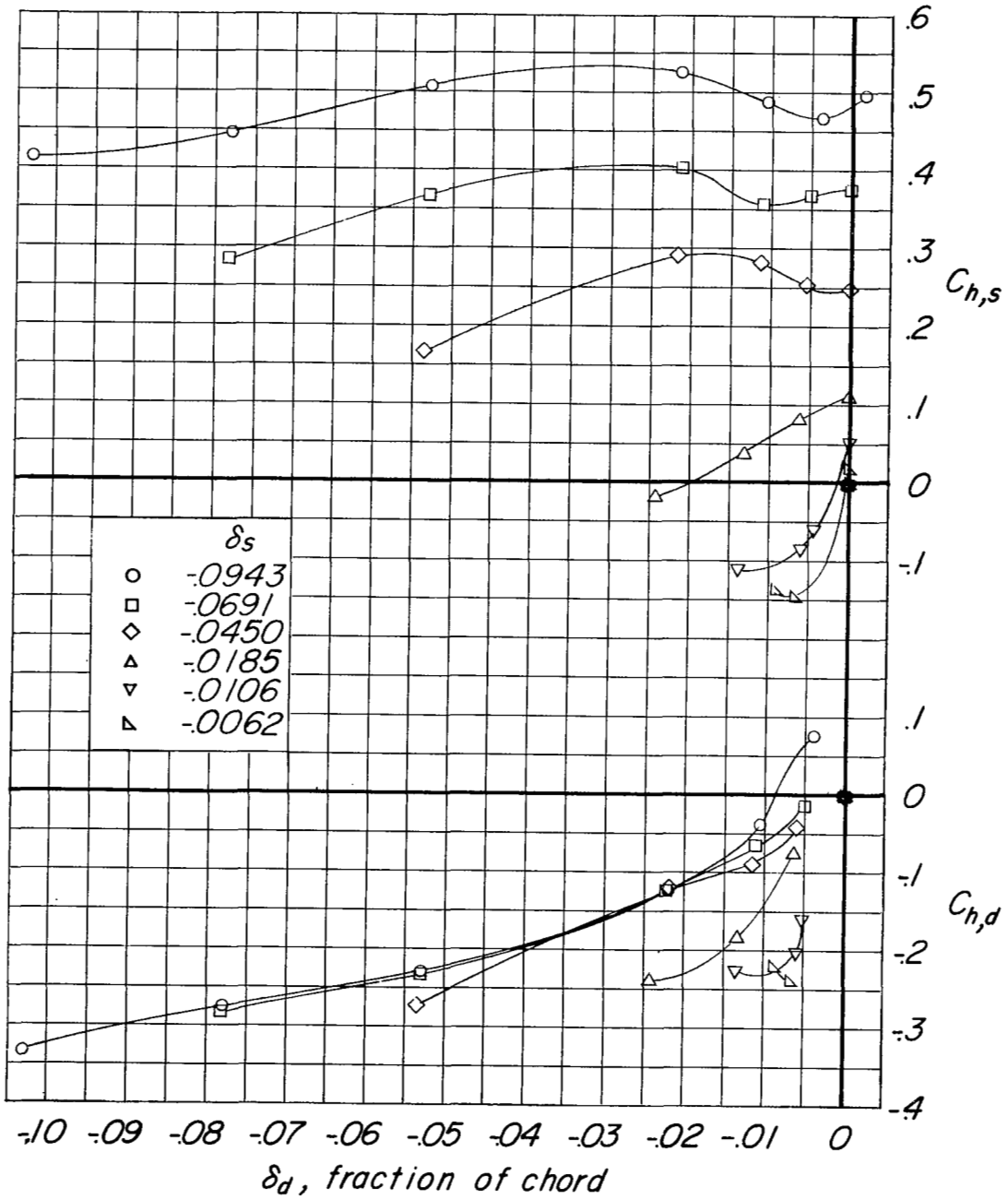
(a) $\alpha = -4^\circ$.

Figure 8.- Variation of hinge-moment characteristics with deflector projection of the spoiler and deflector for a 35° sweptback wing at a Mach number of 0.93.



(b) $\alpha = 0^\circ$.

Figure 8.- Continued.



(c) $\alpha = 4^\circ$.

Figure 8.- Continued.

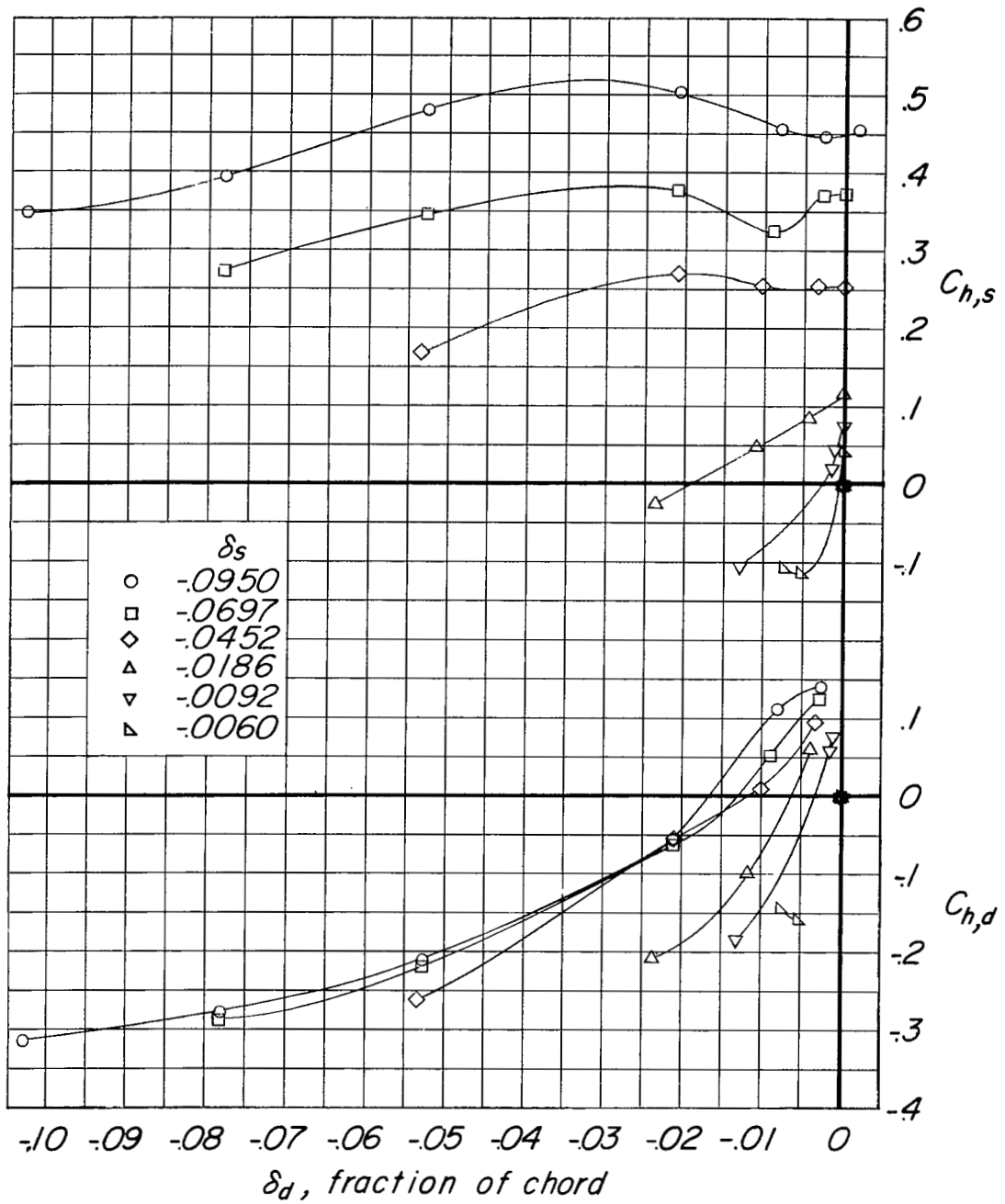
(d) $\alpha = 8^\circ$.

Figure 8.- Concluded.

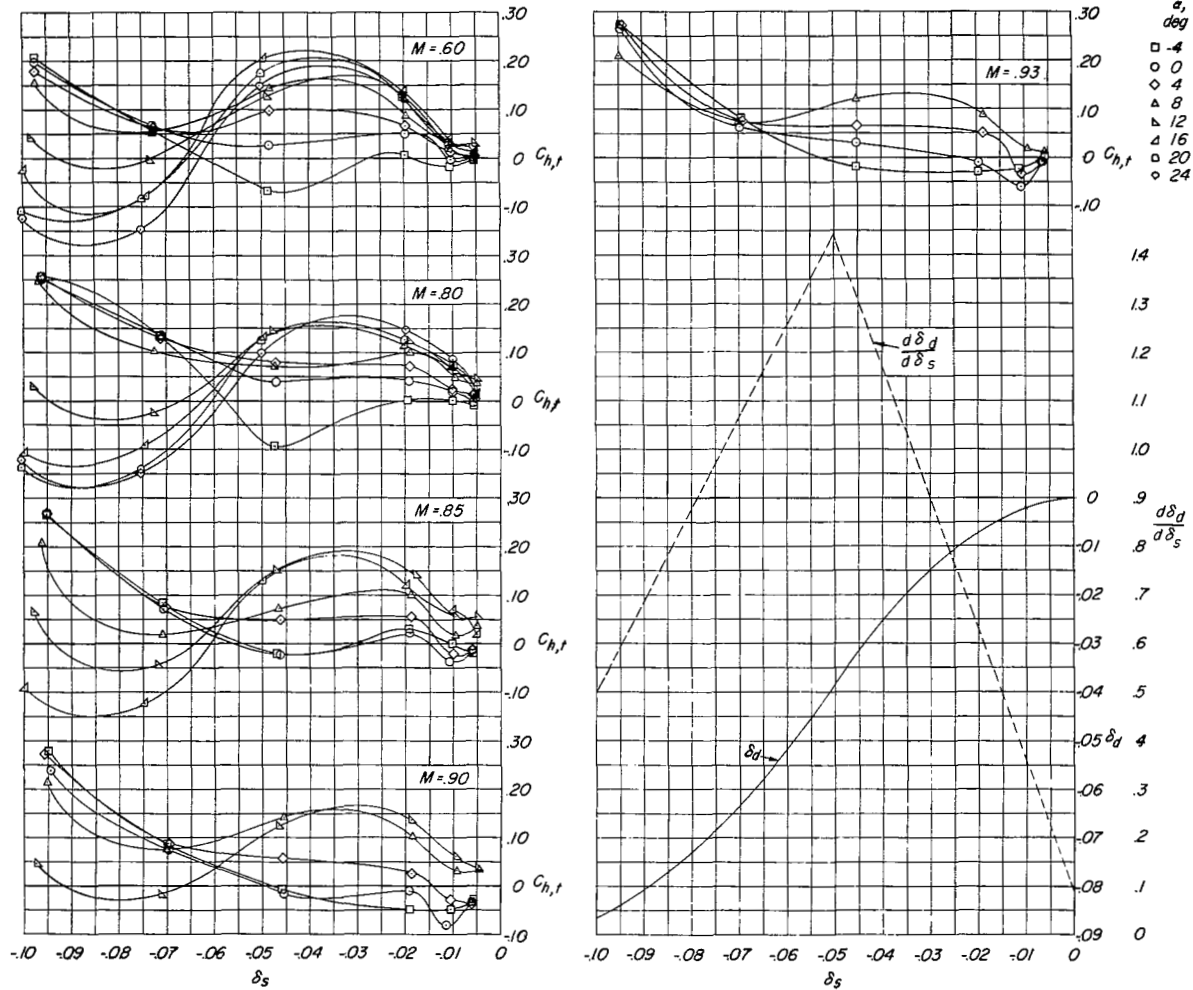


Figure 9.- Variation of total hinge moment produced by varying the ratio of deflector projection to spoiler projection of the spoiler slot deflector with spoiler deflection for several angles of attack.

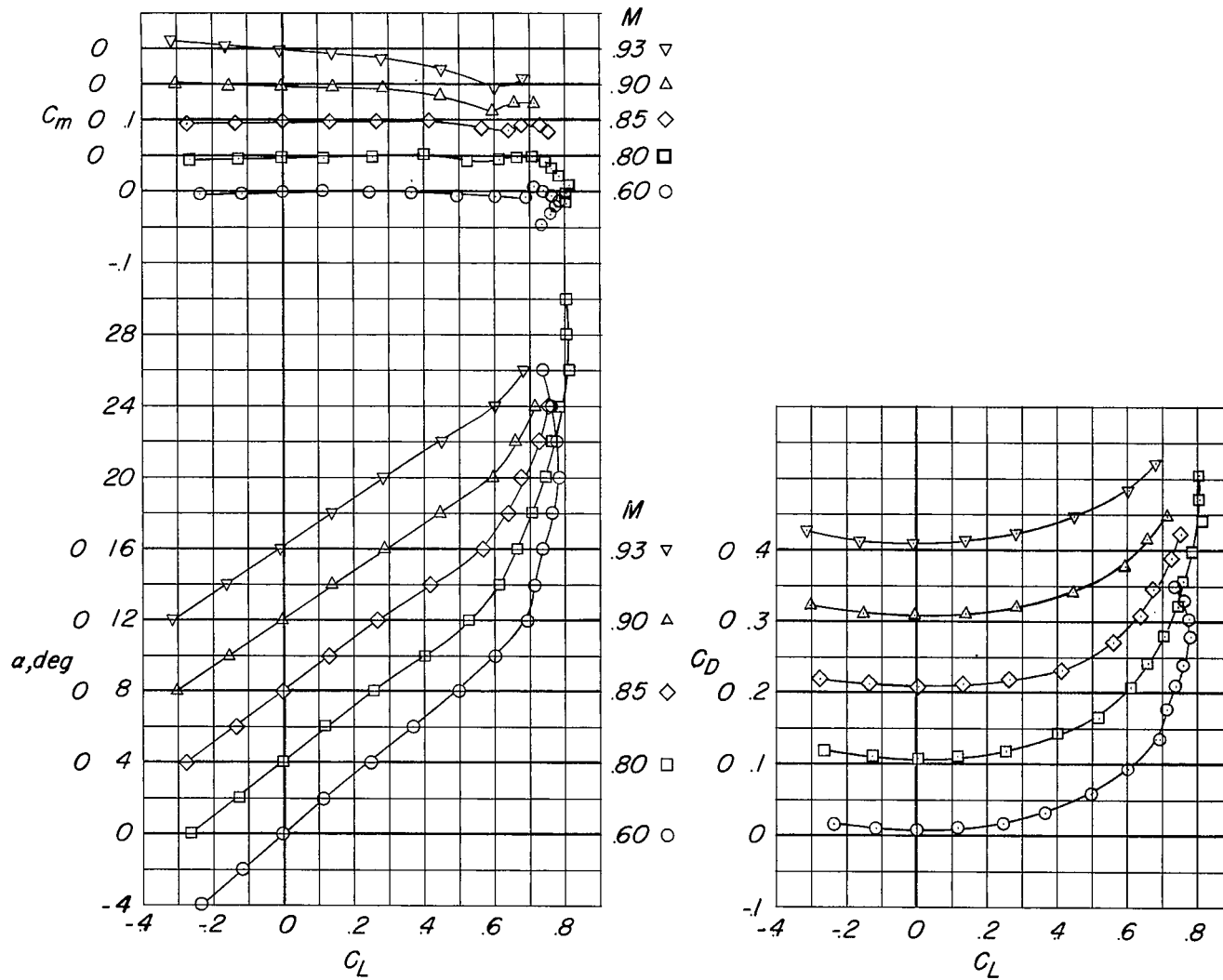


Figure 10.- Variation of angle-of-attack drag and pitching-moment coefficients with lift coefficient for the semispan 35° sweptback wing with the spoiler slot deflector at zero deflection.

NASA Technical Library



3 1176 01437 9078

