

CASE FILE

RM A57D30

COPY

NACA RM A57D30

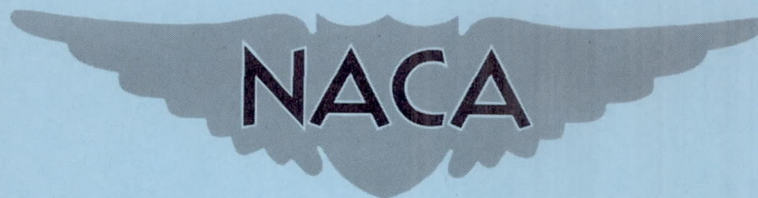

RESEARCH MEMORANDUM

A COMPARISON OF CARRIER APPROACH SPEEDS AS DETERMINED
FROM FLIGHT TESTS AND FROM PILOT-OPERATED
SIMULATOR STUDIES

By Maurice D. White and Fred J. Drinkwater III

Ames Aeronautical Laboratory
Moffett Field, Calif.

NATIONAL ADVISORY COMMITTEE
FOR AERONAUTICS
WASHINGTON

June 19, 1957
Declassified September 14, 1959

NATIONAL ADVISORY COMMITTEE FOR AERONAUTICS

RESEARCH MEMORANDUM

A COMPARISON OF CARRIER APPROACH SPEEDS AS DETERMINED
FROM FLIGHT TESTS AND FROM PILOT-OPERATED
SIMULATOR STUDIES

By Maurice D. White and Fred J. Drinkwater III

SUMMARY

A simplified analog simulator is described which may be used to predict the minimum comfortable approach speeds that would be used in carrier landings for a particular class of airplanes - those that are limited by ability to control altitude. In operation, a pilot maneuvers the simulated airplane longitudinally as he would in flight to arrive at a comfortable approach speed. Predicted speeds obtained from initial tests on several airplanes are compared with values from flight tests in order to indicate the validity of the simulator results. Illustrative application of the simulator to determine whether certain factors are important in influencing the choice of an approach speed is indicated. For this purpose consideration is given the effects of stall warning and some tentative conclusions regarding the effects of engine thrust, engine response, and airplane short-period longitudinal time constant are shown.

INTRODUCTION

With the introduction of jet-propelled aircraft for use on aircraft carriers, it has been reported that the landing-approach speeds selected by the pilots tend to be higher than would have been predicted from previous experience. To enable better predictions of the approach speed it is necessary to know the factors that cause the pilot to select a particular approach speed for each airplane. Flight tests at Ames Aeronautical Laboratory on a large number of fighter-type configurations indicate that there are several possible reasons why pilots are reluctant to make landing approaches at speeds below a selected speed. These include proximity to the stall, poor visibility from the cockpit, unsatisfactory stability and control characteristics, and inability to control altitude or check

sink rates satisfactorily. Of the reasons listed, inability to control altitude is by far the most prevalent, being given for about 70 percent of the configurations tested.

A general program is under way at the Ames Aeronautical Laboratory to gain a better understanding of the factors that limit approach speed and to develop criteria that will enable better predictions of landing-approach speeds. As a part of this program, an analog simulator has been developed to enable a more detailed study of some of the factors that influence the choice of an approach speed. This simulator permits the pilot to maneuver an airplane longitudinally, using the control stick and throttle as he would in flight, and thereby to arrive at a selected approach speed. Such an evaluation would, of course, be expected to compare with flight evaluations only for airplanes for which the flight approach speed was limited by ability to control altitude or check sink rate, rather than by such other factors as visibility from the cockpit or adverse stability and control characteristics.

The present report describes the simulator and the results of preliminary evaluations of several airplanes that were made on it. Flight data for these airplanes, which were all reported to be limited in approach speed by pilots' ability to control altitude, are also shown. The simulator evaluations were made to determine (1) whether satisfactory agreement could be obtained between approach speeds determined on the simulator and in flight, (2) what the pilots' opinions of the simulator were, and (3) the effects on approach speed of changes in several factors.

NOTATION

A_x	longitudinal acceleration, units of gravity
A_z	vertical acceleration, units of gravity
\bar{c}	mean aerodynamic chord, ft
D	airplane drag, lb
F_G	gross engine thrust, lb
g	unit of acceleration, 32.2 ft/sec ²
h	altitude, ft
I	moment of inertia about transverse axis, slug-ft ²

k	factor relating period of second-order system to time constant of first-order system
K	gearing or gain
m	airplane mass, slugs
P	undamped natural period, sec
q	dynamic pressure, lb/sq ft
S	wing area, sq ft
s	Laplace transform variable
T	net engine thrust, lb
V	true airspeed, ft/sec
W	airplane gross weight, lb
W _a	mass flow of air through engine, slugs/sec
C _D	airplane drag coefficient, $\frac{\text{drag}}{qS}$
C _L	airplane lift coefficient, $\frac{\text{lift}}{qS}$
C _{Lα}	lift-curve slope, per radian
C _m	pitching-moment coefficient, $\frac{\text{pitching moment}}{qSc}$
C _{mα}	$\frac{\partial C_m}{\partial \alpha}$, per radian
C _{m$\dot{\alpha}$}	$\frac{\partial C_m}{\partial (\dot{\alpha}c/2V)}$, per radian
C _{m$\dot{\theta}$}	$\frac{\partial C_m}{\partial (\dot{\theta}c/2V)}$, per radian
α	angle of attack, deg
ρ	air density, slugs/cu ft

γ	flight-path angle, radians
ζ	damping ratio for short-period longitudinal oscillation
δ_e	horizontal control deflection, deg
δ_{stick}	control stick deflection, inches at grip
δ_T	throttle deflection
δ_{stab}	stabilizer deflection, deg
$\dot{\theta}$	rate of change of airplane attitude in pitch
τ_a	airplane time constant

Subscripts

app	approach
avail	available
eff	effective
equiv	equivalent

GENERAL DESCRIPTION OF THE SIMULATOR

A block diagram of the simulator is shown in figure 1, and figure 2 shows the physical arrangement of the apparatus. The pilot was supplied with a conventional stick and throttle for control. He perceived airplane altitude as the vertical displacement of a horizontal line on the oscilloscope, at a scale of 10 feet per inch of displacement. Airspeed was indicated on a meter located beside the oscilloscope, and a stall warning was provided by an audible buzzer that sounded continuously at lift coefficients greater than a preset value. A second, shorter horizontal line on the oscilloscope was available to indicate vertical acceleration by vertical displacement of the line.

It will be seen from the block diagram of figure 1 that movement of the stick results in changes in lift coefficient which are combined with dynamic pressures appropriate to the airspeed in order to produce vertical accelerations and flight-path-angle changes in the airplane. Through flight-determined (or any desired) curves of drag coefficient as a function of lift coefficient, the variations of C_D are made appropriate to

the variations in C_L , and are combined with dynamic pressures to produce longitudinal accelerations and consequent airspeed changes in the airplane.

Movements of the throttle produce thrust increments that contribute to the longitudinal acceleration and airspeed changes. The angle of attack was omitted from the simulation and, as a consequence, the following assumptions with regard to the action of the thrust vector were introduced:

1. The thrust effect on lift was simulated only to the extent of including in C_L for the C_L-C_D curves the component of whatever thrust was required to balance the drag at about the approach speed and angle of attack.
2. Thrust increments due to throttle manipulation were assumed to act along the flight path rather than the airplane axis, and hence produced no lift.

Gravity effects on the horizontal acceleration were included as a function of flight-path angle; the effects of flight-path-angle changes on the vertical acceleration were neglected.

DETAILED DESCRIPTION OF THE SIMULATOR

The control stick was geared linearly to the airplane lift coefficient through a first-order time constant. Actual airplane responses are usually better described by second-order systems. In order to approximate reasonably the time variations of the second-order system with a first-order system, the time constant for the first-order system was set at a value equal to the time required for the second-order step response to reach 63 percent of the final value. The degree of approximation involved by this substitution is indicated by the curves in figure 3(a), which shows a comparison of the step responses for the first-order system with the responses to equivalent second-order systems. Figure 3(b), which is based on the data of figure 3(a), presents a convenient curve for determining the equivalent first-order time constant when the undamped natural period and damping ratio of the second-order-system characteristics of the actual airplane are given.

An attempt was made to conduct evaluations with the actual airplane gearings of stick movement to C_L , as determined from flight tests. No stick-force gradient was supplied in conjunction with these tests, and the pilots found the control unacceptably sensitive and the trim position difficult to locate. Accordingly the gearing was changed to a value of 20 inches (at the stick grip) per unit C_L , which was considered satisfactory and was used with no stick-force gradient, for all the tests reported here.

The throttle control was geared linearly to thrust, full rearward producing zero thrust and full forward, full thrust. Three different arrangements of time delay between throttle control movement and thrust were investigated. Descriptive time histories showing the thrust response to throttle movement for each of the arrangements noted below are given in figure 4.

1. No time lag between throttle movement and thrust development.
2. Time delay of 0.5 second. Thrust lags throttle by about 0.5 second regardless of rate or amplitude of throttle movement.
3. Variable thrust response. Thrust response is approximately first order, the value of the first-order time constant increasing linearly with the amplitude of the throttle movement.

For the last case the circuitry provided for initiation of a new time sequence each time the throttle was reversed or the thrust reached about 95 percent of the steady-state increment called for.

An additional factor found desirable in the investigation was the provision of a random but repeatable disturbance in A_z , a time history of which is shown in figure 5. The need for a disturbance was indicated during preliminary simulator tests when one of the pilots, deprived of adequate physical references, unconsciously imposed rates of descent that were higher than usual and thereby arrived at higher approach speeds. The disturbance was introduced as a series of steps in vertical acceleration, applied through a 1-second, first-order time constant at random time intervals and in either positive or negative direction. The steps were of uniform amplitude, corresponding, according to pilots' impressions, to moderate atmospheric turbulence. It is of interest to note that a random amplitude of disturbance that was tried initially raised objections on the grounds that infrequent large-amplitude disturbances tended to upset a precise approach and were unrealistic in simulating atmospheric turbulence; also it created an uncertainty in the pilot's mind as to whether in a given period of flying he had encountered the same degree of disturbance that he had in another period.

FLIGHT TESTS

Airplanes

Four airplane configurations were tested in flight and on the simulator. These were:

Airplane	Engine	Speed brakes	Gross weight (landing con- figuration), lb	Wing area, sq ft	Wing M.A.C., ft	Estimated value of I , slug-ft ²	Maximum T/W available, max. military power
F7U-3	J46-WE8B	Split wing - flaps retracted	21,030	535	13.69	43,750	0.32
F7U-3	J46-WE8B	Split wing - flaps extended	21,030	535	13.69	43,750	.32
F9F-6	J48-P8	Retracted	13,440	300	8.96	26,700	.42
FJ3	J65-W4	Retracted	13,078	288	8.08	20,000	.53

Figure 6 shows drawings of the test airplanes, and figure 7 shows the gearings between the control stick and the horizontal control surfaces.

Instrumentation

Item	Instrument
Airspeed Altitude Elevator angle Throttle control position Normal acceleration Longitudinal acceleration Angle of attack Pitching velocity Tail-pipe area (where variable)	Standard NACA recording instruments.
Tail-pipe pressure	Single probe recording on NACA pressure recorder. Calibrated on thrust stand.
Tail-pipe temperature Engine rpm	Camera photographing pilot's instrument panel.

Tests

Field carrier-landing evaluation runs were made on the test airplanes by three NACA pilots to determine the minimum comfortable approach speeds. The speeds quoted correspond to landing weights defined as the weight empty plus 1000 pounds fuel per engine. In addition to determining the approach speeds the pilots were asked to give the reason for limiting the approach speed. Of the three NACA test pilots who conducted the tests, two, pilots B and C, were experienced carrier pilots; the third, pilot A, had no carrier experience, but was an Air Force fighter pilot who has had considerable experience as an NACA test pilot.

The approach speeds used by Navy pilots in actual carrier operations were determined for the F9F-6 and the F7U-3 airplanes by interrogating a group of the pilots during a carrier evaluation cruise.

Additional flight tests in the test airplanes were made at the Ames Aeronautical Laboratory to obtain supplementary information applicable to the landing-approach configurations. Static tests were made to obtain the variations of α , C_D , and δ_e with C_L . The values of C_L and C_D were computed from flight measured quantities, using the relationships:

$$C_L = \frac{W}{qS} (A_Z \cos \alpha + A_X \sin \alpha) - \frac{1}{qS} (F_G \sin \alpha)$$

$$C_D = \frac{W}{qS} (A_Z \sin \alpha - A_X \cos \alpha) + \frac{1}{qS} (F_G \cos \alpha - W_a V)$$

The dynamic longitudinal stability and horizontal control effectiveness characteristics were evaluated from the responses to elevator pulses and steps. The period and damping ratio were computed from the simplified equations

$$P = 2\pi \sqrt{\frac{I}{C_{m_{\alpha}} q S \bar{c}}}$$

$$\zeta = \frac{C_{L_{\alpha}} q S}{mV} - \frac{(C_{m_{\theta}} + C_{m_{\alpha}}) q S \bar{c}}{I} \frac{\bar{c}}{2V}$$

A series of throttle bursts were performed by applying step movements to the throttle at an altitude of about 5000 feet, and at about the approach speed in order to document the dynamic response characteristics of the engine.

RESULTS AND DISCUSSION

Flight Tests

Comparison of NACA and Navy pilots approach speeds.- As shown by the data of table I, the approach speeds used by Navy pilots tend to be higher than the values selected by the NACA pilots. This difference is probably due to the fact that the NACA pilots were selecting a minimum comfortable approach speed, while the Navy pilots were defining merely an operational approach speed, which could be reduced further if there were sufficient reason. This argument is supported by flight data obtained during a carrier cruise and presented in figure 8. The results of 44 landings made with the F7U-3 by four skilled Navy pilots are shown in figure 8. The values of approach speed were obtained from radar instrumentation on the carrier, with suitable corrections for carrier and wind velocities, and have been corrected to the standard landing weight by multiplication of the measured value by the square root of the ratio of the landing weight to the actual weight. The data show that while the average approach speed is about 113 knots, values as low as 105 knots occur, albeit infrequently. The values selected by the NACA pilots are in agreement with the lower values of the curve as would be expected when a minimum value is sought. The fact that the NACA tests were made under the less hazardous conditions of field landing might also contribute to lower values for the NACA tests.

Static aerodynamic characteristics.- The variations of C_D , α , and δ_e with C_L for the test configurations are shown in figure 9. Included in this figure are the modified curves of C_D against C_L that were used in the simulator tests. Figure 10 shows the variation of the drag with velocity and the variation of the thrust required to balance the drag. These curves were determined from the data of figure 9 by solution of the equations:

$$W = C_L q S + T \sin \alpha$$

$$D = C_D q S = T \cos \alpha$$

It is of interest to observe, in connection with the data of figure 10, that for the two extremes in curve shape represented by the two F7U-3 configurations, one of which represents flight on the unstable side of the D-V curve throughout the available speed range, the pilots selected the same approach speed. From this it is apparent that the speed for minimum drag, which has occasionally been proposed as a fundamental criterion for defining approach speed, will not apply for all configurations.

Dynamic longitudinal stability characteristics.- The dynamic stability characteristics of the test configurations, shown in figure 11(a), were obtained on an analog computer by trial and error fitting of measured

responses in A_z , α , and $\dot{\theta}$, following pulses and steps of the horizontal control surfaces. Some variation in value with speed is indicated but the variation is relatively small. From these curves the values of the equivalent first-order time constants were obtained by the use of figure 3(b), and these are shown in figure 11(b).

Engine response characteristics.- Figure 12 shows some results of the engine response tests. There are differences indicated in the response characteristics of the engines which are associated with the type of engine control system used. For the F7U-3 (fig. 12(a)), the thrust lags the throttle movement by about 1/2 second regardless of the amplitude of the throttle step. For the thrust level to which these data apply, which is the level required for carrier approaches, the engine operates at constant rotational speed and the thrust is modulated basically by changing the fuel flow and the tail-pipe area. This method of engine control is not commonly used.

For the F9F-6 and FJ3 airplanes (figs. 12(b) and 12(c)), the thrust response to a throttle step follows essentially a ramp variation with little time delay, which, for convenience of simulator representation, may be considered as a first-order system, the time constant of which increases with the amplitude of the throttle step. This type of response is characteristic of engines in which the thrust varies with the rotational speed, and is hereafter referred to as "variable time constant."

Landing-approach time histories.- Several typical approach time histories obtained during the field carrier evaluations are shown in figure 13.

Applicability of the Simulator

As noted in the Introduction, the simulator, as described herein, is best adapted to study cases in which the approach speed is limited by the ability to control altitude and has been used almost exclusively for such cases. Although the simulator could, by obvious modifications, be adapted to study cases in which the approach speed is limited by some of the other factors mentioned, no serious efforts have been made as yet along this line. Until the validity of such modifications are proven it should be understood that the results obtained from the simulator, such as those presented in this report, are applicable primarily to configurations for which ability to control altitude is the limiting factor. In cases where ability to control altitude is not the limiting factor indicated by the simulator, then only stall proximity could be given as an alternative factor.

Simulator validity - comparison of approach speeds.- The validity of the landing-approach simulator is determined by several factors.

Foremost of these is, of course, the ability of the pilot to determine the same approach speed on the simulator and in flight. Table I and figure 14 show a comparison of the approach speeds determined by the two methods by each of the three pilots and the average of their values. The average values as determined on the simulator are seen to agree with the flight values within 3 knots. This agreement would be influenced by the stall-warning margin provided. In the simulator operation, the pilots considered that the stall warning, set for a C_L equivalent to a 5-knot speed margin, represented an effective limit of operation which should not be exceeded in ordinary maneuvering. No attempt was made to relate this margin to the actual flight stall-warning margins; the figure used was selected simply as a reasonable value. If the stall warning had been set at another value of C_L , then the pilot would in some cases have reported a correspondingly different approach speed. These few cases of dependence of the agreement on the particular margin of C_L chosen do not represent a serious objection to the simulator validity, however, because it is unlikely that in flight the pilot would ordinarily maneuver up to $C_{L_{max}}$; rather, he would select an approach speed such that ordinary maneuvers would still leave a margin of C_L available for emergency situations.

Insufficient comparisons have been made between simulator predictions and flight approach speeds to permit a general conclusion that the simulator in its present simplified form will always enable accurate predictions. The importance of this particular attribute of the simulator should not be overestimated, however; its adaptability to the study of individual factors that influence the ability to control altitude, discussed in a later section of this report, is regarded as an equally important attribute.

Repeatability of simulator results.- A second test of the simulator validity is the repeatability of the test results. Check runs of various configurations made on different days indicated that the selected approach speeds were repeatable within 3 knots, which is considered satisfactory.

Pilots' impressions.- A third test of the simulator would be whether the pilots could relate visual indications of a simulated airplane approach to their impressions of the behavior of the airplane in flight. Generally speaking, the simulator, in the simplified form that is described here, requires that the pilots extract information about the behavior of the airplane from a lesser number of perceptual channels than they have available in flight. Also certain aspects of the airplane behavior on the simulator seem somewhat unrealistic. For example, on the simulator, throttle actuation with the stick fixed resulted in speed changes only, while in flight the speed might change by lesser amounts, some of the energy from the engine thrust change producing a rate of climb or descent. Significant differences exist between airplanes in this

regard, apparently as a result of differences in longitudinal trim characteristics, increased ease of control being associated with lesser speed changes.

As a consequence of such factors, the pilots felt that on the simulator they were unable to capture completely the feeling that they were flying a particular airplane and, accordingly, approach speeds and reasons for limiting approach speeds could not be quoted with as much assurance as they would be from flight tests. Despite these reservations the pilots were able to obtain valuable information from the simulator regarding the variables that influence ability to control altitude. The comparisons of flight and simulator approach speeds discussed previously indicate that the pilots were able to evaluate approach speeds to an acceptable degree of accuracy. Also, two of the three pilots indicated that for all four configurations they limited their approach speeds for the same reason they had in flight, namely because of inability to control altitude at low speeds. The third pilot (pilot B) indicated that while his reason for limiting speed in flight agreed with those of the other pilots, his reason for limiting speed on the simulator was because of stall proximity as represented by the stall-warning buzzer. It should be noted that these are the only reasons that can be given on this simulator.

The causes of this difference between reasons assigned by the pilots can, of course, only be speculated upon. An obvious possibility is that some pilots are affected to a greater degree than others by the lack of such factors as static longitudinal stability, attitude changes with speed, and the sensations of vertical and longitudinal accelerations, which are not included on the simulator. An illustration of this is afforded by the fact that in the present study pilot C required an indication of the vertical acceleration on the scope in addition to the altitude, while the other two pilots preferred to fly without this added visual indication, and, in fact, considered it distracting and accordingly detrimental. This is not to say that they did not miss the perception of accelerations, but that they could not interpret this additional visual information.

Because of the aforementioned lack of complete simulation, some reservations were felt as to the possibility of using the simulator to evaluate the effects of different airplane characteristics on the approach speed. In this regard it was observed that the pilots were able to identify which of the four configurations was being tested by means of impressions gained during simulator operation. This feat was undoubtedly made easier by the fact that there were large differences in certain characteristics among the test configurations. Aside from the degree of ability to control altitude through the longitudinal control, there were two factors in particular which aided pilots in identification. One of these was a speed stability as indicated by the rate of change of airspeed resulting from flying at speeds removed from that at which the thrust

balanced the drag. The speed stability variations with airspeed are largely a function of the shape of the drag-air-speed curve. The other factor was the thrust-weight ratio available ($\Delta T/W$) which determined to a large extent the pilot's ability to control the rate of airspeed change. As indicated by the curves of figure 10 and the data in figure 15, there were large differences in both of these characteristics among the four configurations tested which aided in their identification.

In summary, it was the opinion of the pilots that the ability to distinguish on the present simulator the effects of large changes in airplane characteristics is fairly well established, but the effects of smaller changes would be difficult to determine. Increasing the complexity of the simulator to include more accurate simulation of such other factors as stability and control characteristics may improve it from the standpoint of pilot feel, sensitivity to smaller changes in airplane characteristics, and ability to study the effects of these factors on approach speed.

Simulator Studies of Individual Factors

An important feature of the landing-approach simulator is its flexibility, which indicates its possible use in a study of factors that influence the pilot in arriving at an approach speed. In order to illustrate the use of the simulator for this purpose a few test results are presented here, in which the effects on selected approach speed of several different variables are considered. Because the scope of these tests is limited and because the results quoted may be a function of the particular simulator conditions (i.e., what values were used simultaneously for other factors), the results given should not be considered as general.

Stick gain (C_L per unit stick movement).- As previously noted, attempts to use stick gains corresponding to those of the airplane in flight (fig. 9) met with objections from the pilot on the grounds that the control was too sensitive, and it was found necessary to reduce the gain to a value of 0.05 C_L per inch stick grip movement before it was considered acceptable. It was inferred that the lack of the stick-force gradient made the higher stick gains unacceptable. This conclusion is supported by results presented in reference 1 which indicate a moderate stick-force gradient to be necessary for acceptable control feel characteristics. The fact that it was possible to operate on the simulator with zero force per unit acceleration with a low stick gain, in contrast with the findings of reference 1, does not mean that such operation would be acceptable in flight. The pilots accepted this simplification on the simulator in order to reduce the number of variables to be considered in preliminary studies. However, the fact that reasonable correlation of the approach speeds was obtained in the absence of accurate simulation of the stick forces and stick gains could be interpreted as indicating

that this factor was not of first-order importance in defining approach speeds on the simulator for these airplanes. The extent to which the approach speed for these airplanes would be altered in flight by changes in longitudinal stability is, of course, not defined by these results, particularly where the effects of negative stability are concerned. In fact, adverse stability and control characteristics have been primary factors in limiting flight approach speeds for several airplane configurations recently evaluated.

Throttle response.- In the evaluation of the basic airplane configurations, the approximation to the engine response characteristics shown in figure 4 were used. For the variable time constant case, the value assigned to the time constant was set equal to the time required for the ramp-like response of the actual thrust to reach 63 percent of the final increment. To evaluate the effect of engine time constant on the selected approach speed, evaluations were also made with the engine time constant reduced to zero. The results in table II show that with the simplified simulator arrangement used the effect of the time-constant change was insignificant in that the differences in approach speed were within the repeatability of the data.

The reason for the lack of effect of engine response is indicated in the typical time histories of landing approaches in flight (fig. 13) and of evaluation maneuvers on the simulator shown in figure 5. The throttle motions used in maneuvering are seen to consist of a series of small discrete steps with intervals between steps of the order of 1 second or greater. For the variable time-constant case, the small amplitude of the thrust steps would be associated with small time constants, giving almost instantaneous responses. For the case of 1/2-second time delay, the value of the time lag is presumably small enough so that it does not affect the pilots' impressions adversely enough to affect the approach speed on the simulator. The degree to which longer time delays or larger time constants would influence approach speed has not been established.

Thrust margin.- The margin of engine thrust available for maneuvering (thrust greater than that required for level flight at about the approach speed) was varied to determine the effect of this factor on the approach speed. The results shown in figure 15 indicate that while thrust values greater than those provided on the actual airplane do not influence the approach speed on the simulator, some increase in approach speed accompanied decreases in thrust margin below about 0.2 of the airplane weight. The effect was particularly evident for the pilots who consciously employed the same technique on the simulator and in flight of using the throttle for the primary altitude control at low approach speeds (pilots B and C). This greater reliance on throttle for altitude control would tend to make these pilots more sensitive to differences in the margin of thrust available.

The data of figure 15 indicate an additional factor that could result in increased landing-approach speeds with increasing gross weight for a particular airplane. Not only would the stalling and stall-warning speeds be increased with the increased wing loading, but the available thrust margin in terms of $\Delta T/W$ would be reduced with consequent increases in approach speed.

CONCLUDING REMARKS

Minimum comfortable approach speeds for carrier-type landings can be determined by the use of a landing-approach simulator that incorporates the basic performance parameters of the airplane - lift, drag, weight, and thrust. Flight tests indicate that the approach speeds so determined must be revised upward if on the aircraft any other detrimental factors appear; that is, poor stability or control characteristics, severe buffeting, presence of unacceptable stalling characteristics, restricted visibility from the cockpit, etc. In simulator evaluations by three NACA test pilots, average approach speeds for four airplane configurations were determined which agreed with flight values within 3 knots. Average approach speeds selected in flight by Navy pilots were about 5 knots higher than those of the NACA pilots. Available flight data on approach speeds of different airplanes cover a rather limited range of values, and the number of configurations to which the simulator has been applied is relatively limited, so that the range of applicability of the simulator has yet to be established.

The use of the simulator to examine various factors that might influence the selection of the approach speed is illustrated by several results which, because of the limited scope of the tests, must be regarded only as tentative. For the four airplane configurations tested, reduction of the engine time constant from values equivalent to those of flight to a value of zero had no effect on the selected approach speed. However, reduction of margin of thrust available (above that required for level flight) to values less than about 0.2 of the airplane weight was indicated to result in increases in the approach speed.

Ames Aeronautical Laboratory
National Advisory Committee for Aeronautics
Moffett Field, Calif., Apr. 30, 1957

REFERENCE

1. Harper, Robert P., Jr.: Flight Evaluations of Various Longitudinal Handling Qualities in a Variable-Stability Jet Fighter. WADC Tech. Rep. 55-299, July 1955.

TABLE I.- COMPARISON OF APPROACH SPEEDS DETERMINED ON SIMULATOR WITH THOSE DETERMINED IN FLIGHT

Airplane	Navy average (four pilots)	Pilot A		Pilot B		Pilot C		Average of NACA pilots	
		Flight	Simulator	Flight	Simulator	Flight	Simulator	Flight	Simulator
FJ3	^a 116-118	113	115	111	114	113	113	112	114
F7U-3 Brakes in	115	104-109	107	104-109	106	109	105	107	106
F7U-3 Brakes out		104-109	Not evaluated	104-109	106	109	107	107	107
F9F-6	119	114	111	114	108	114	114	114	111

^aData from Patuxent Flight Test Rep. BIS-21168, FT 31-0150, on YFJ-3.

TABLE II.- EFFECT OF ENGINE RESPONSE ON THE APPROACH SPEED DETERMINED ON THE SIMULATOR

Airplane	Simulated flight response	Pilot A		Pilot B		Pilot C	
		Approach speed for simulated flight response	Approach speed for instantaneous response	Approach speed for simulated flight response	Approach speed for instantaneous response	Approach speed for simulated flight response	Approach speed for instantaneous response
FJ3	Variable time constant	115	115	114	114	113	114
F7U-3 Brakes in	0.5 sec. delay			106	106	105	107
F7U-3 Brakes out	0.5 sec. delay			106	108	107	107
F9F-6	Variable time constant	111	111	108	108	114	112

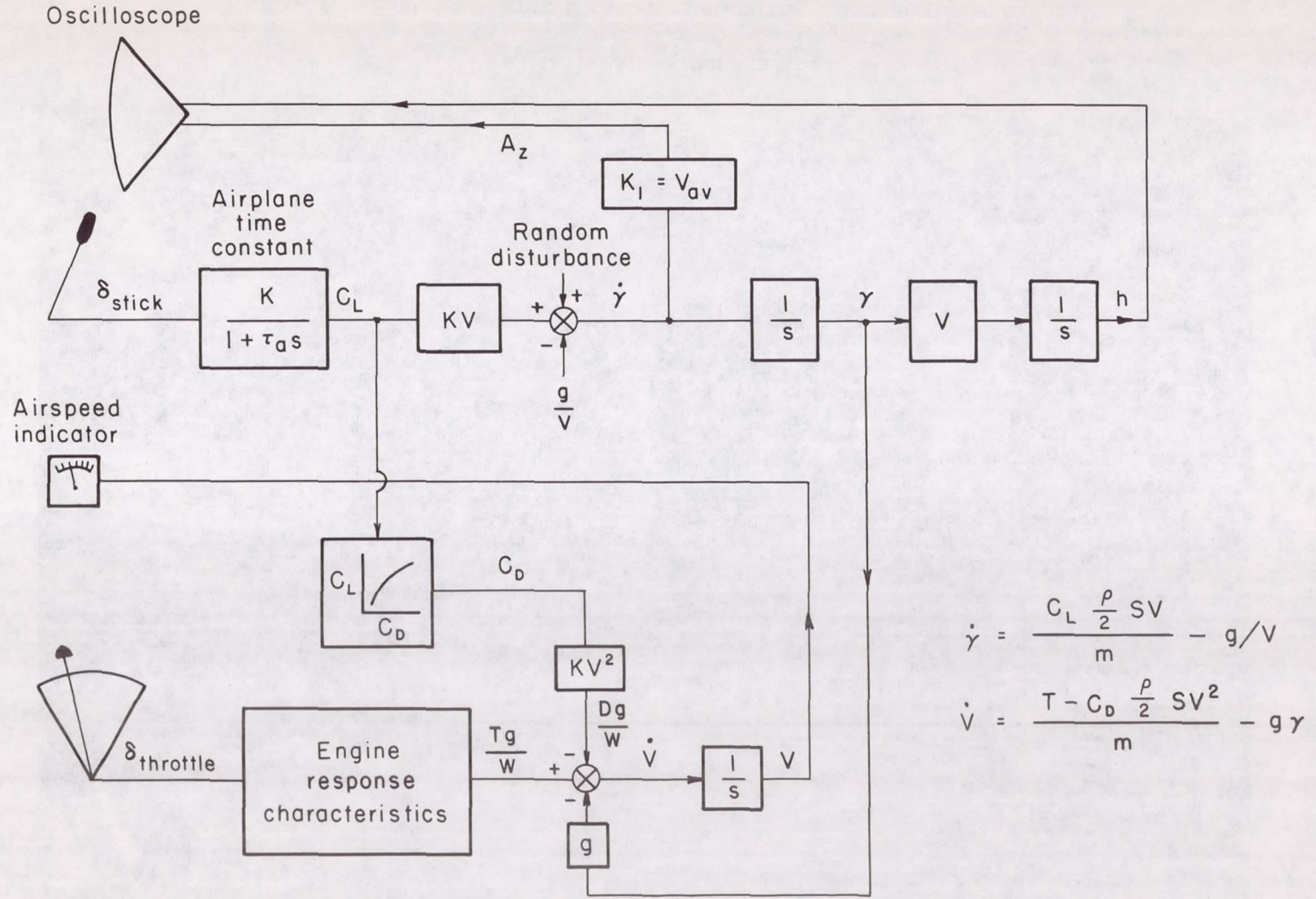
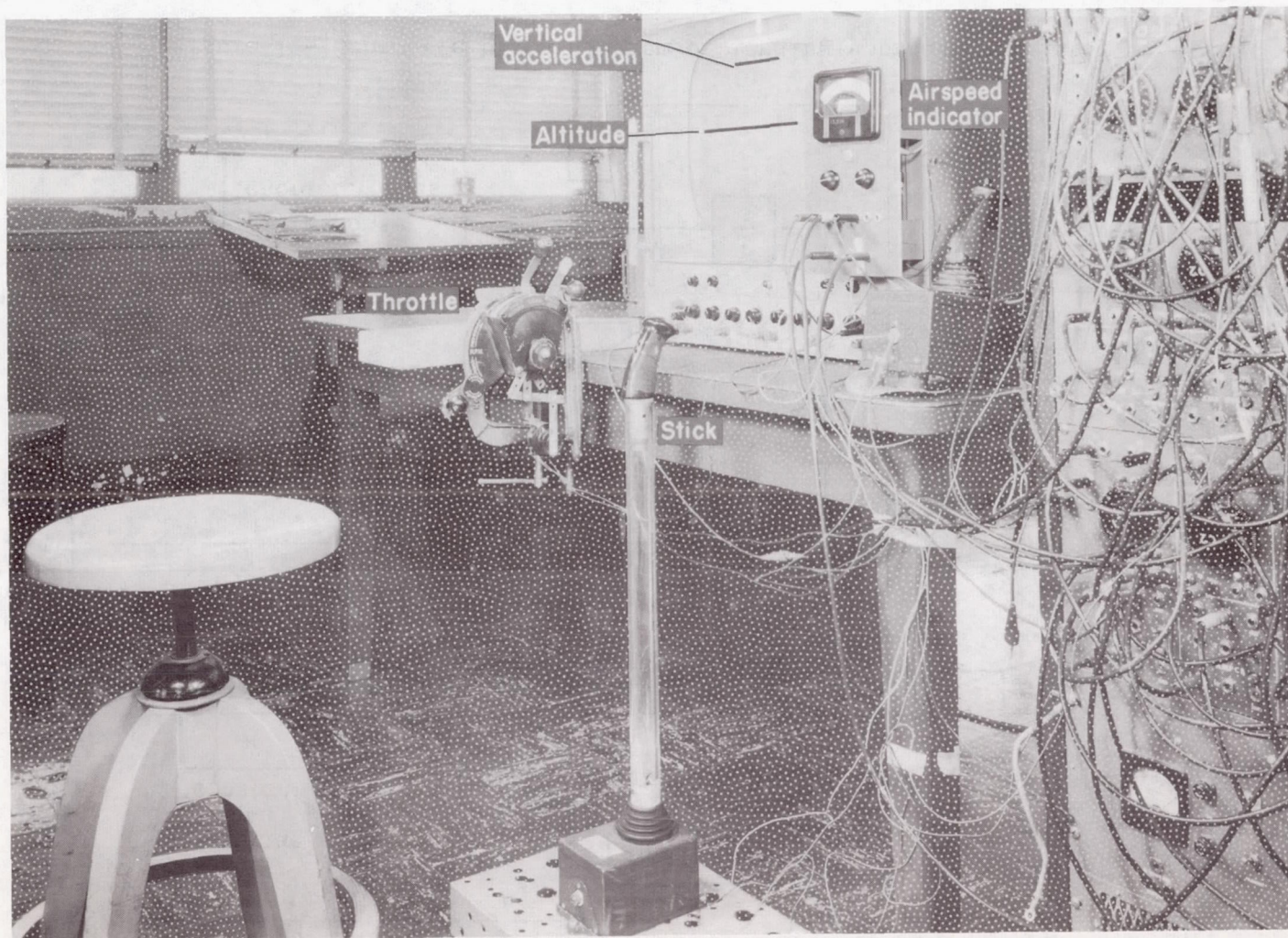

Figure 1.- Schematic block diagram of landing-approach simulator.



(a) General arrangement.

A-21273.1

Figure 2.- Physical arrangement of landing-approach simulator.

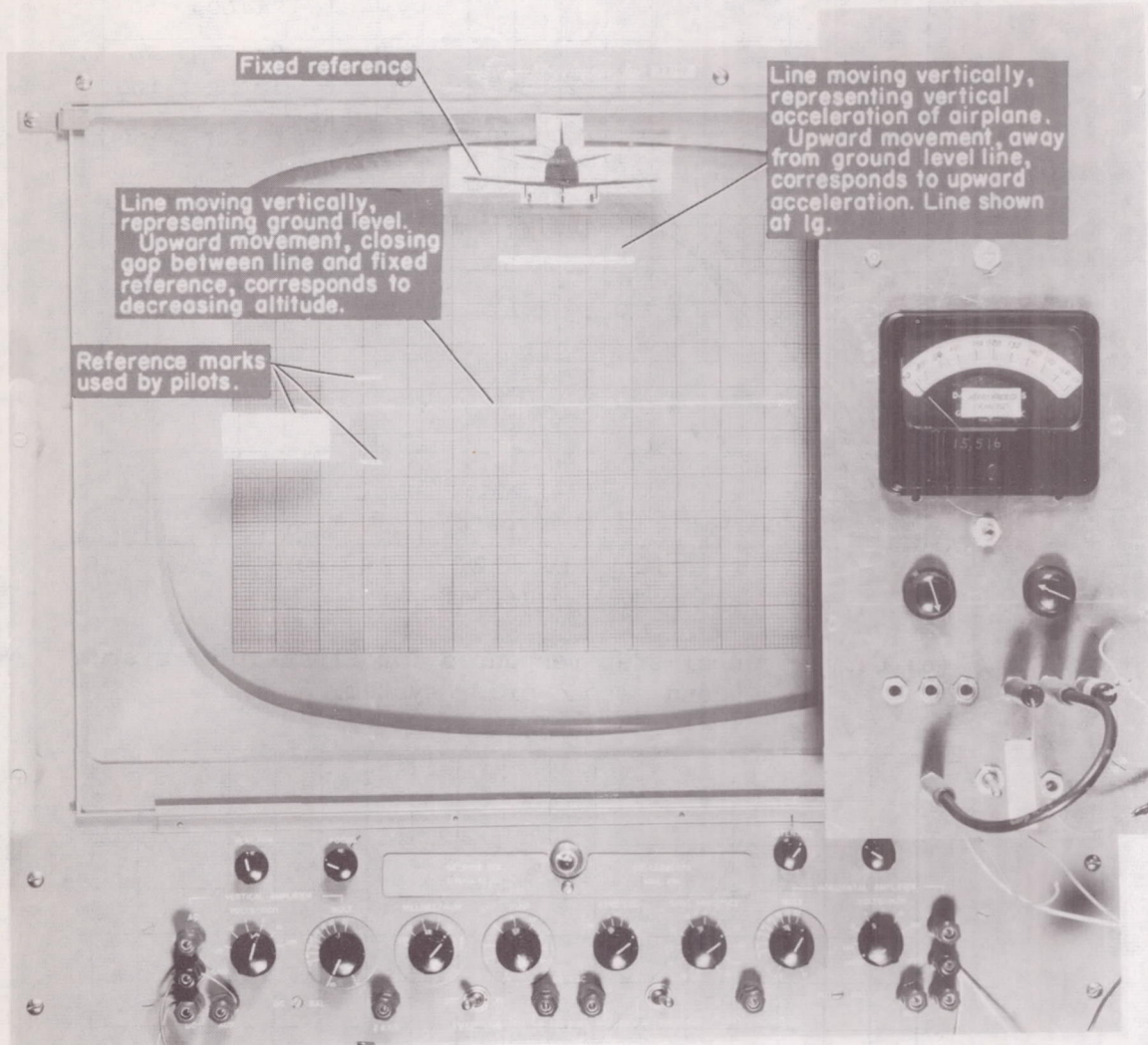

(b) Visual presentation to the pilot.

Figure 2.- Concluded.

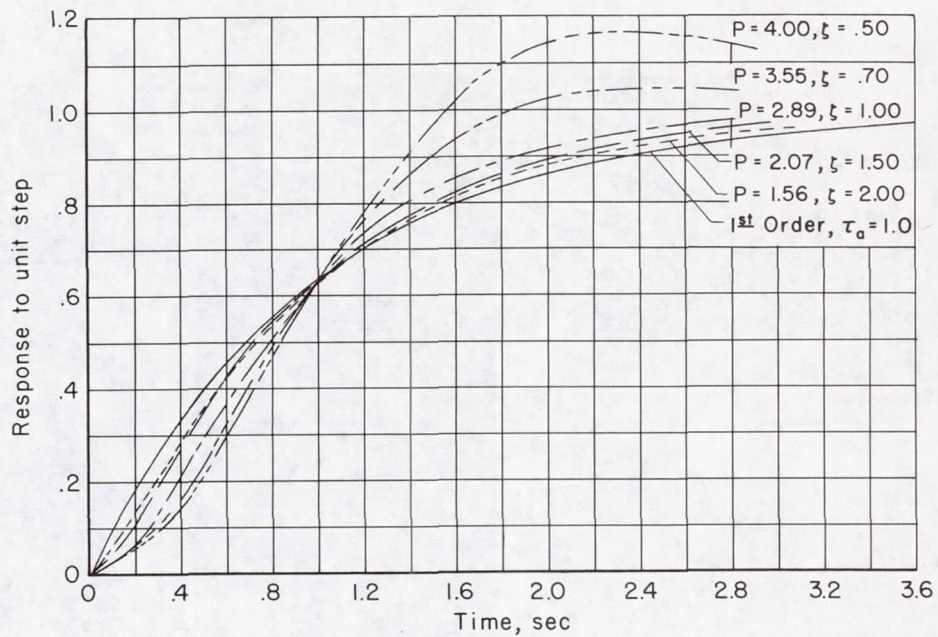

(a) Comparison of step responses for first-order system and second-order system.

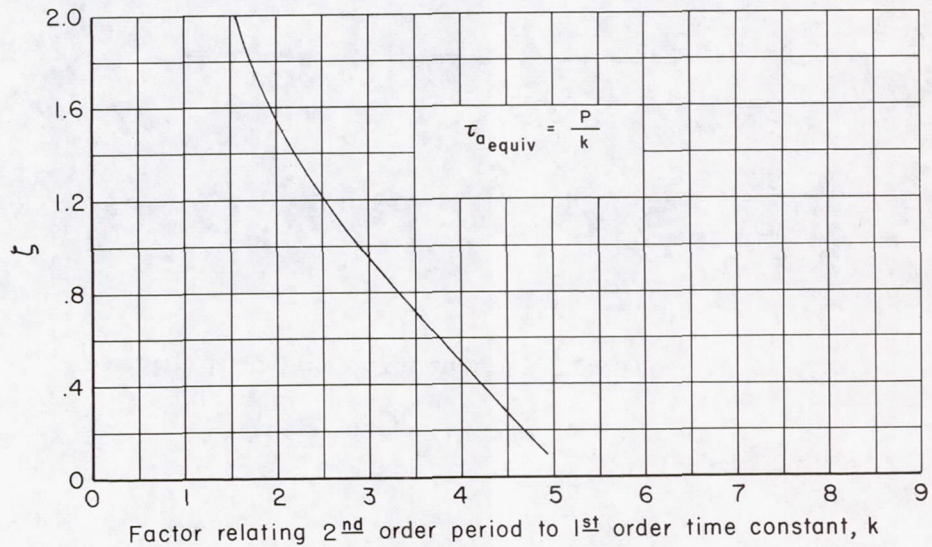

(b) Curve for estimation of first-order time constant equivalent to a given second-order system period and damping ratio.

Figure 3.- Comparative characteristics of second-order system and equivalent first-order system.

———— Small input
 - - - - Large input

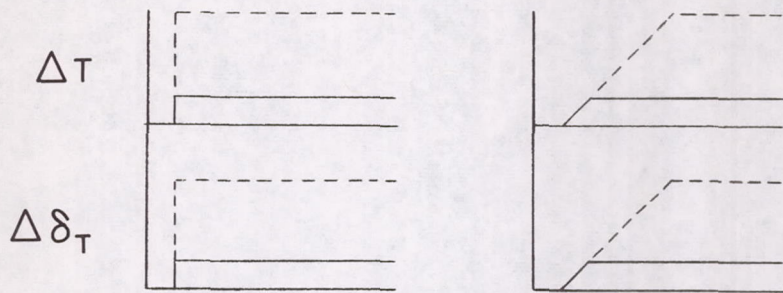

(a) No time lag.

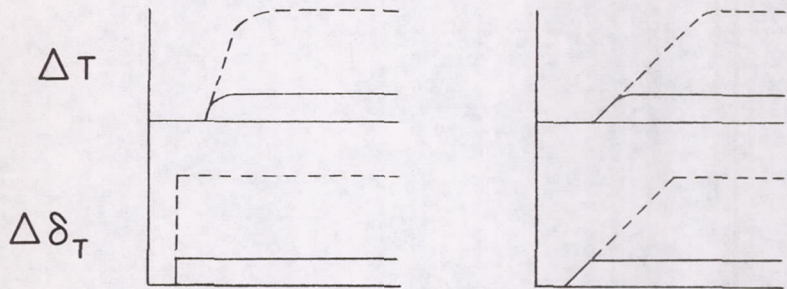

(b) Time delay of 0.5 sec.

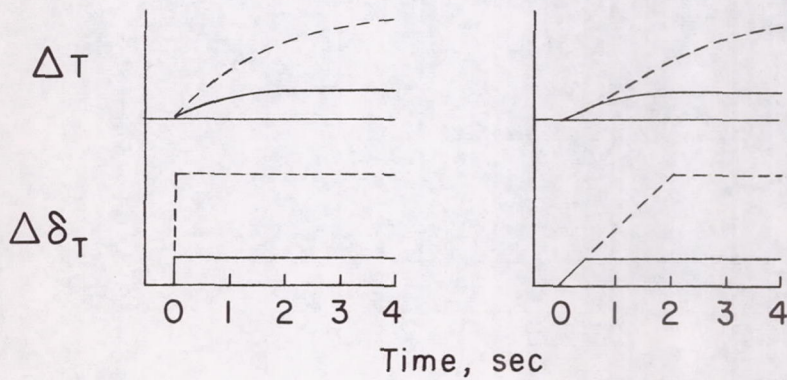

(c) Variable thrust response.

Figure 4.- Sketches showing thrust responses for different engine time-constant arrangements used on simulator.

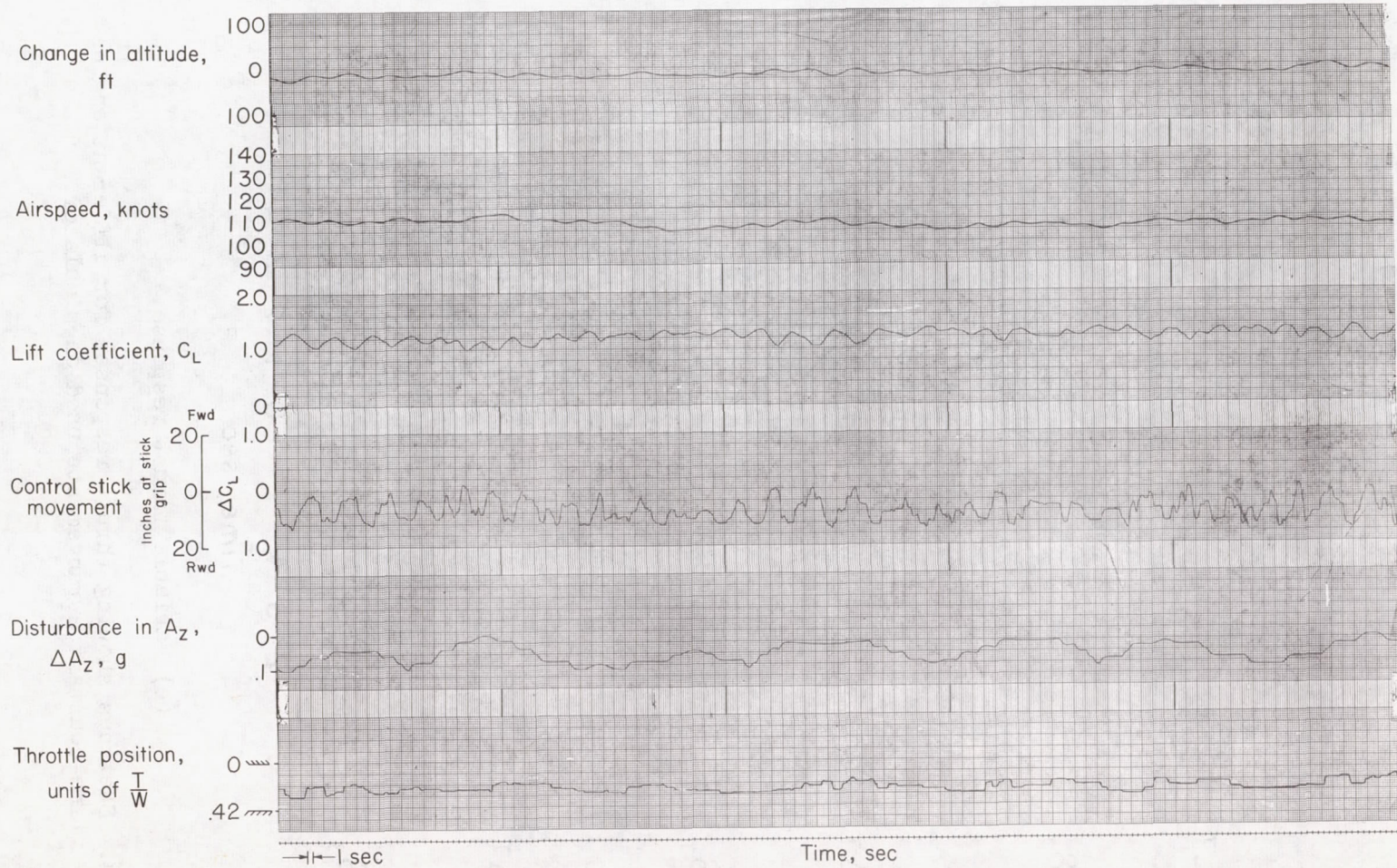

(a) Pilot A with F9F-6 airplane.

Figure 5.- Time history of a typical evaluation to determine approach speed on the simulator.

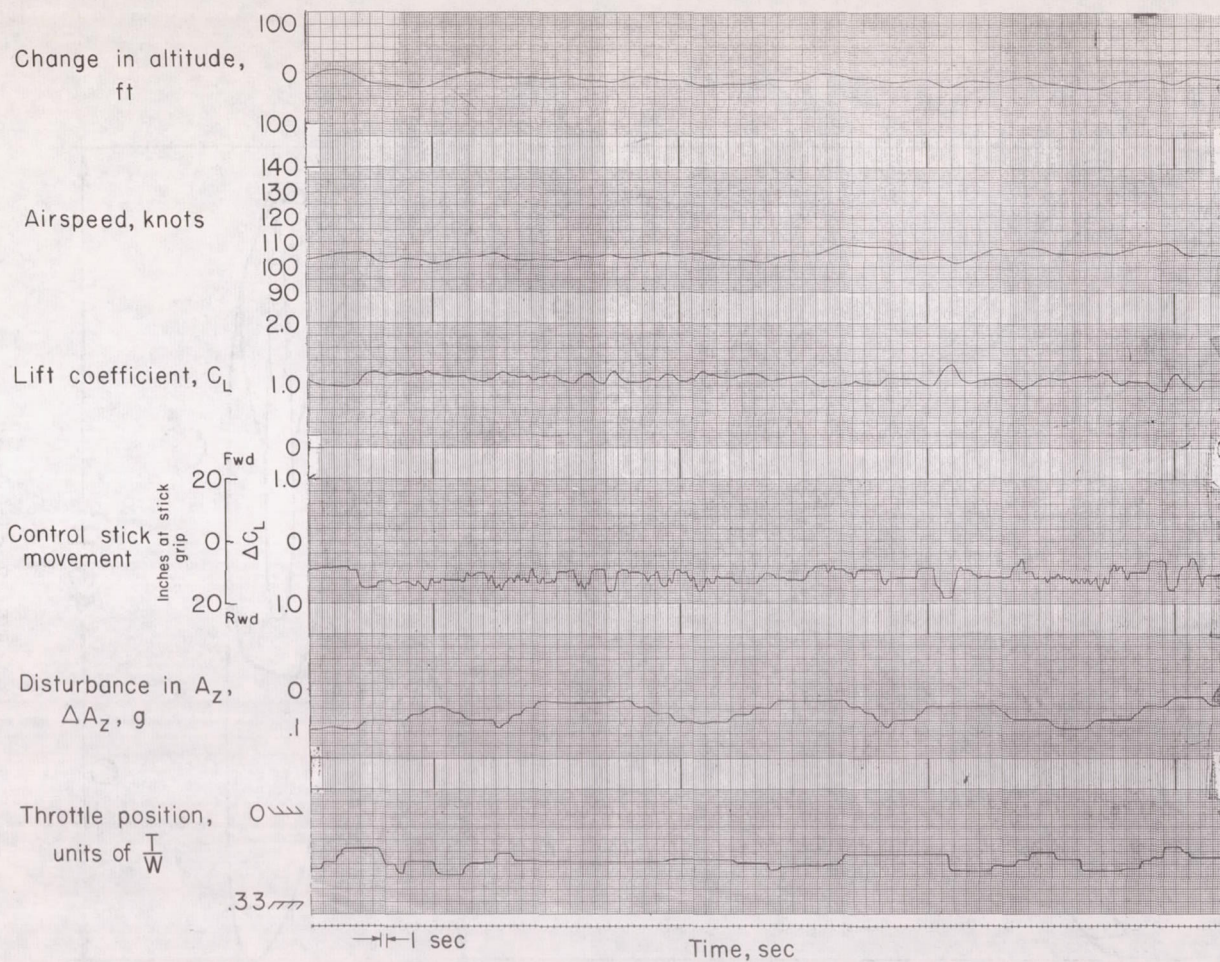

(b) Pilot B with F7U-3 airplane; brakes in.

Figure 5.- Concluded.

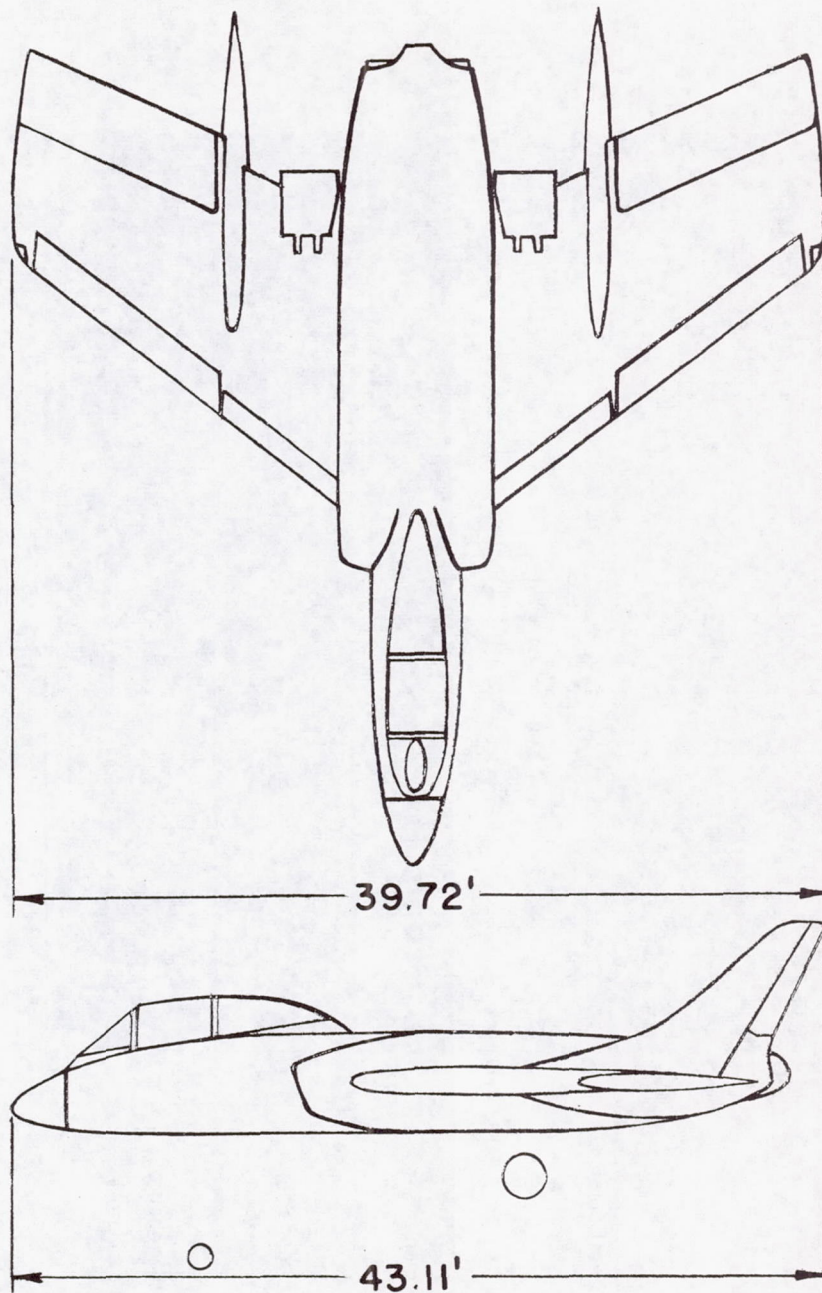

(a) F7U-3 airplane.

Figure 6.- Airplanes tested in present investigation.

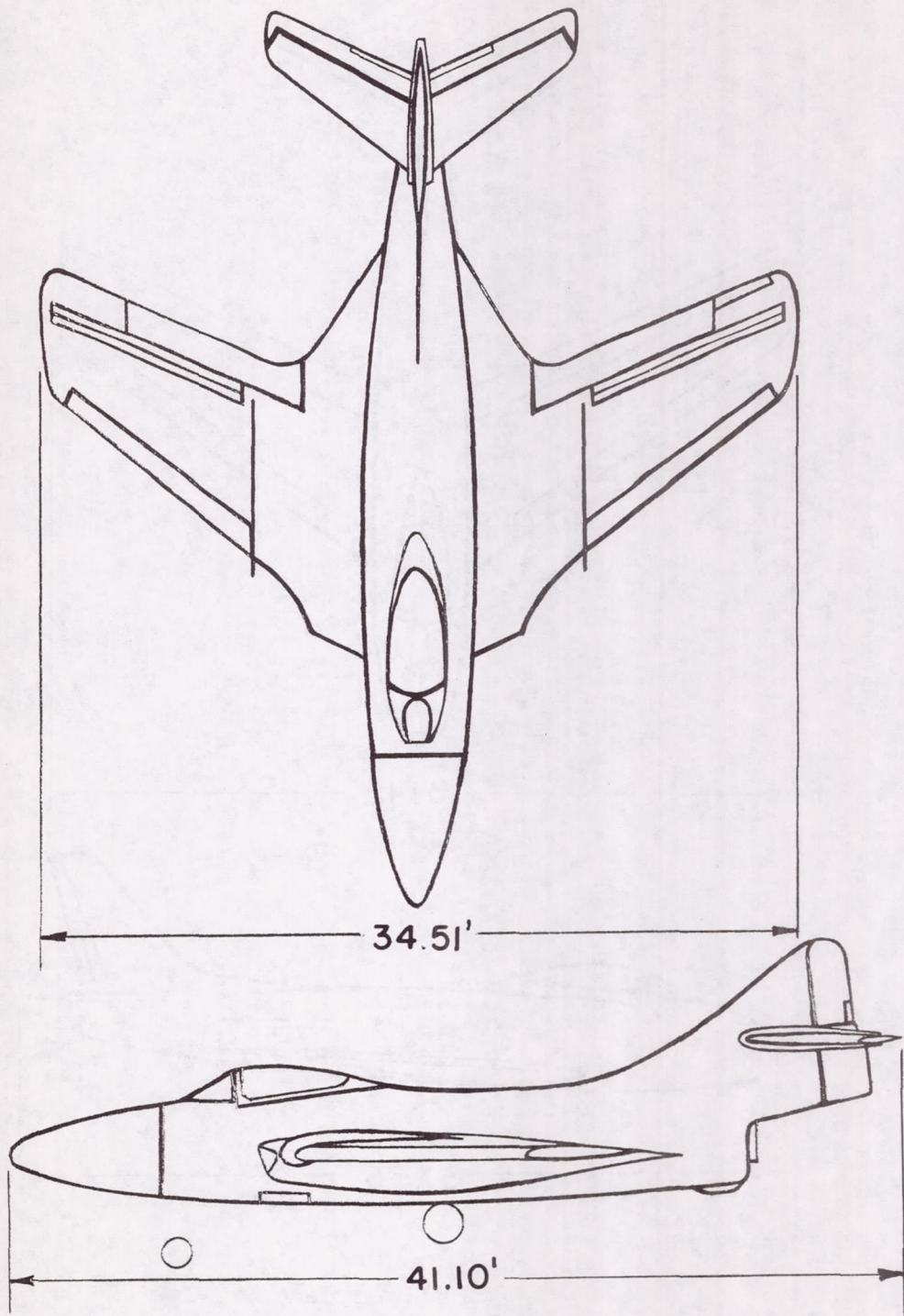

(b) F9F-6 airplane.

Figure 6.- Continued.

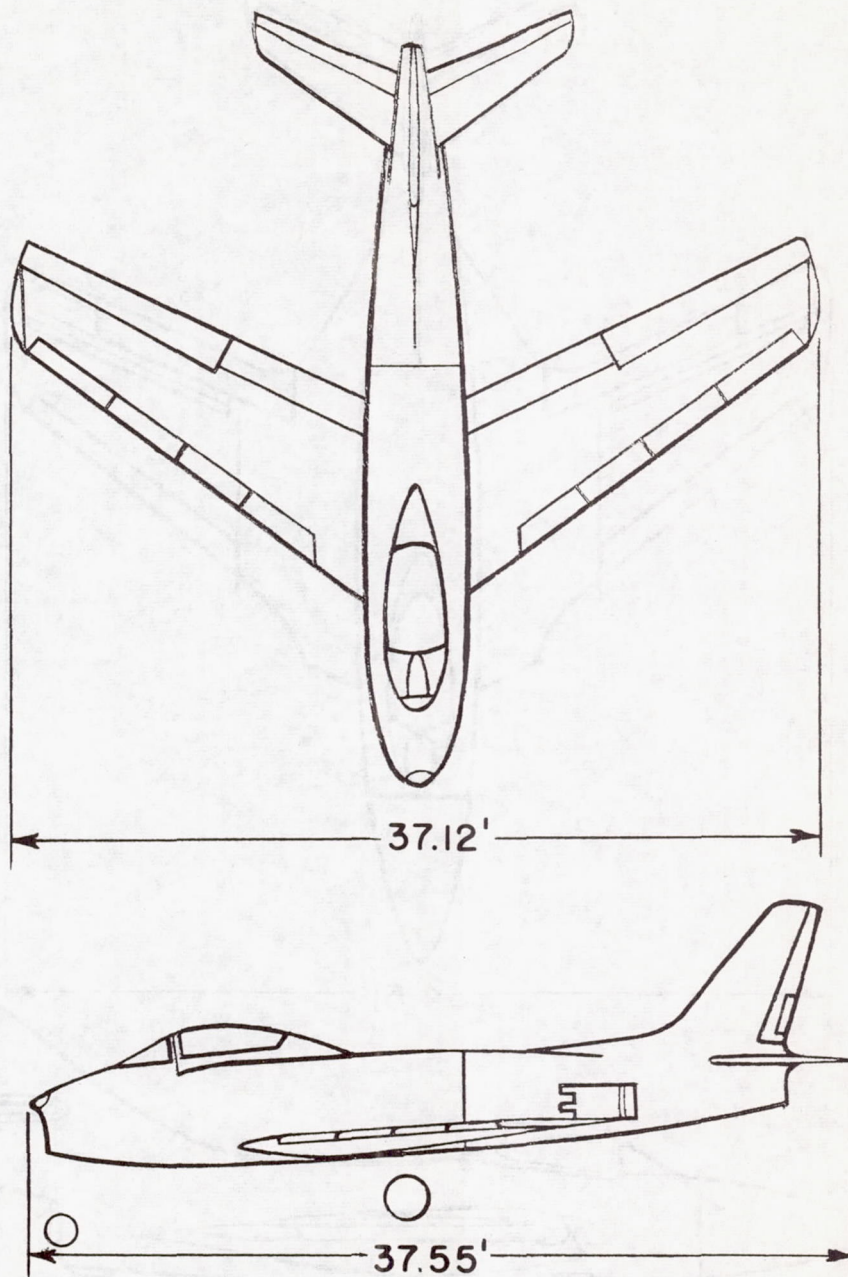

(c) FJ3 airplane.

Figure 6.- Concluded.

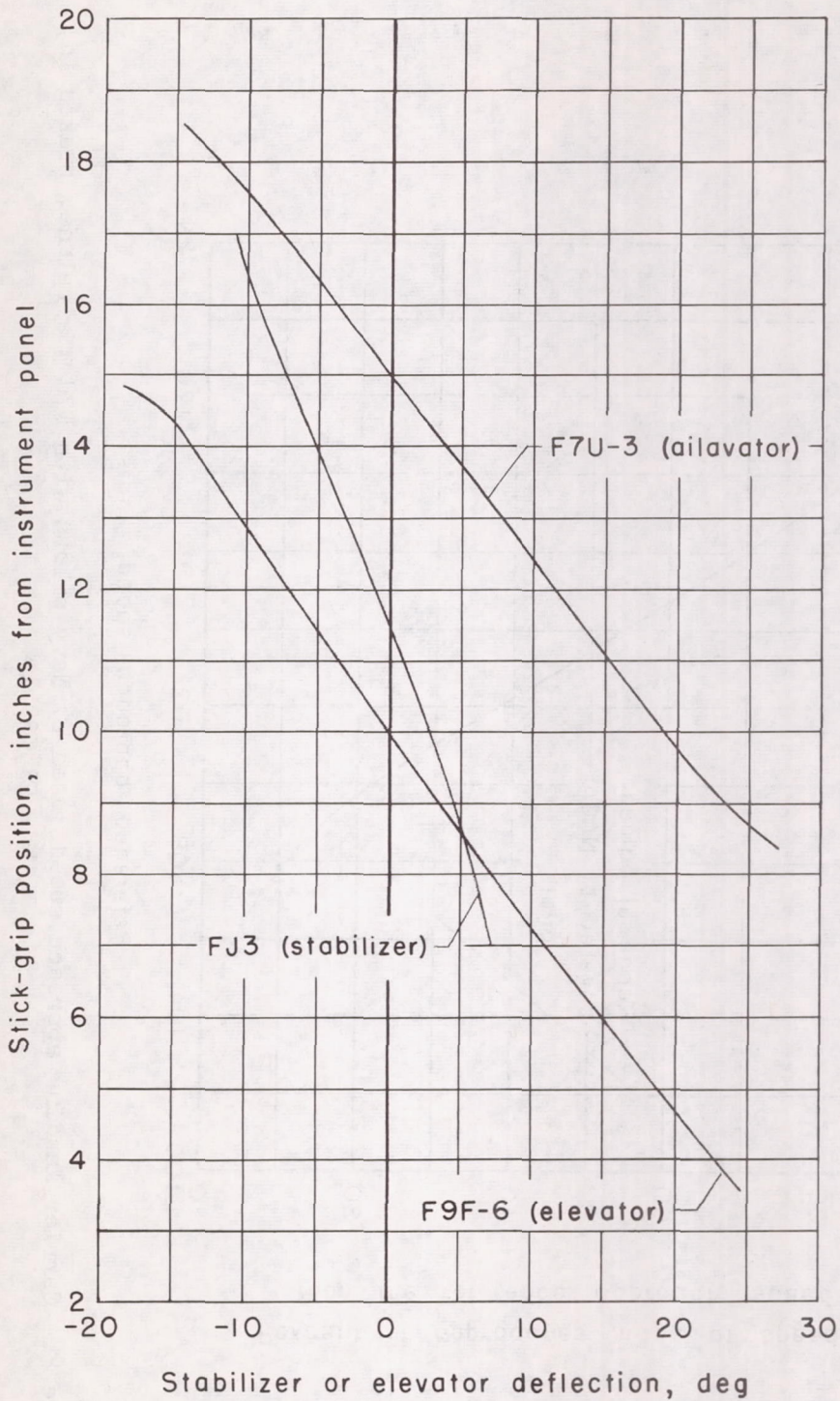

Figure 7.- Relationship between stick position and horizontal control surface deflection for the test airplanes.

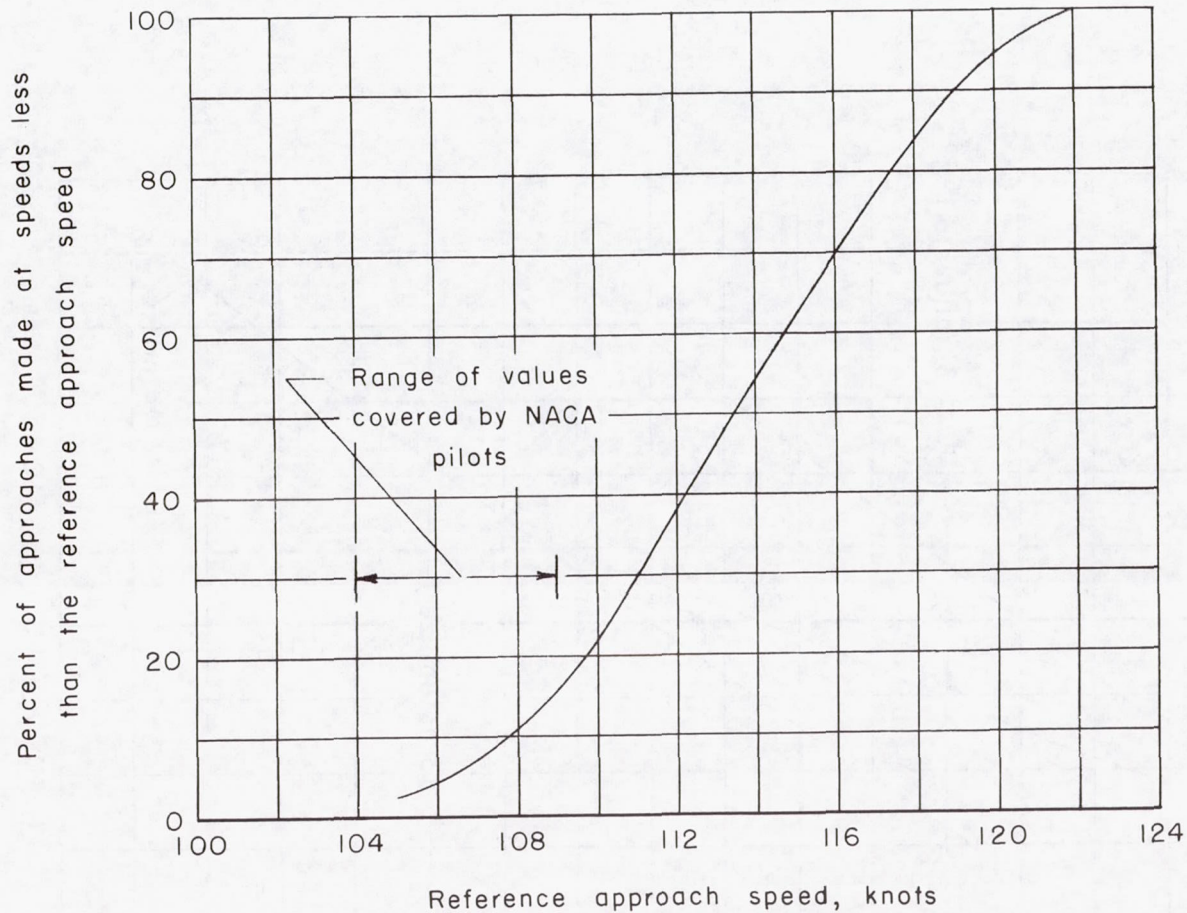
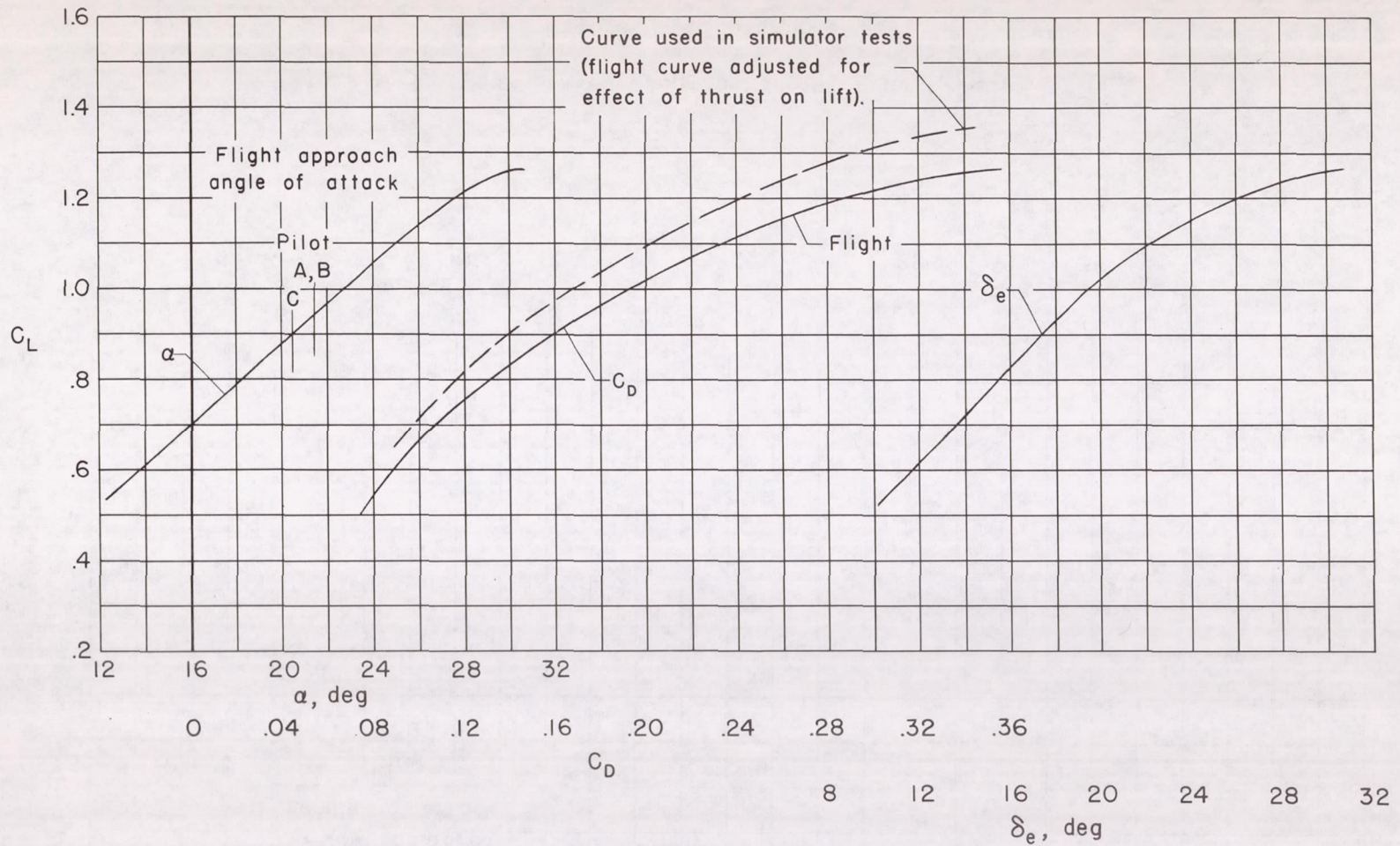
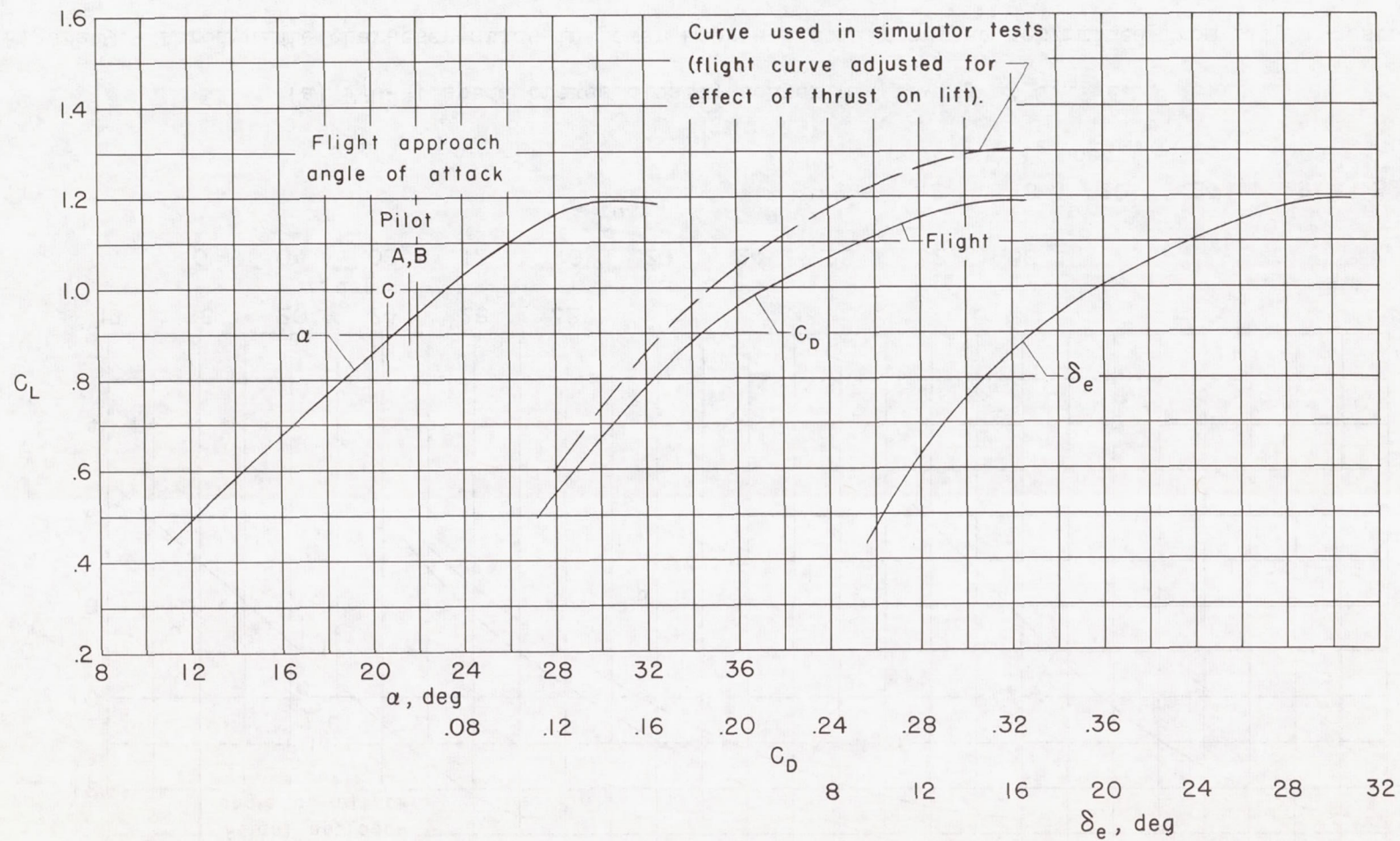

Figure 8.- Carrier landing approach speeds used by Navy pilots with F7U-3 airplane, brakes in;
 $W = 21,030$ lb.



(a) F7U-3; speed brakes closed; center of gravity at $0.13 \bar{c}$.

Figure 9.- Aerodynamic characteristics in power approach condition, as determined from flight tests.



(b) F7U-3; speed brakes open; center of gravity at $0.13 \bar{c}$.

Figure 9.- Continued.

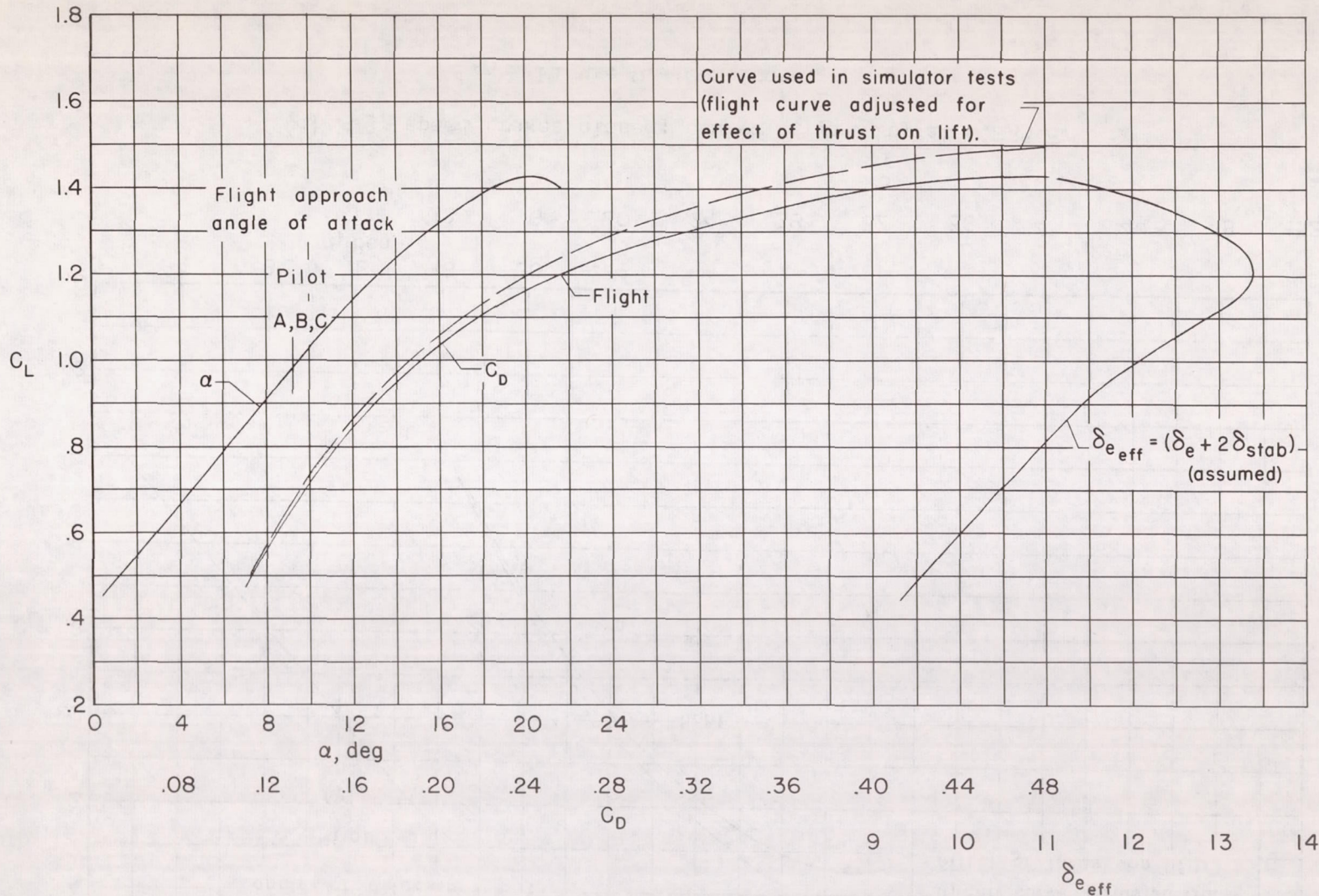

(c) F9F-6; speed brakes closed; center of gravity at $0.28 \bar{c}$.

Figure 9.- Continued.

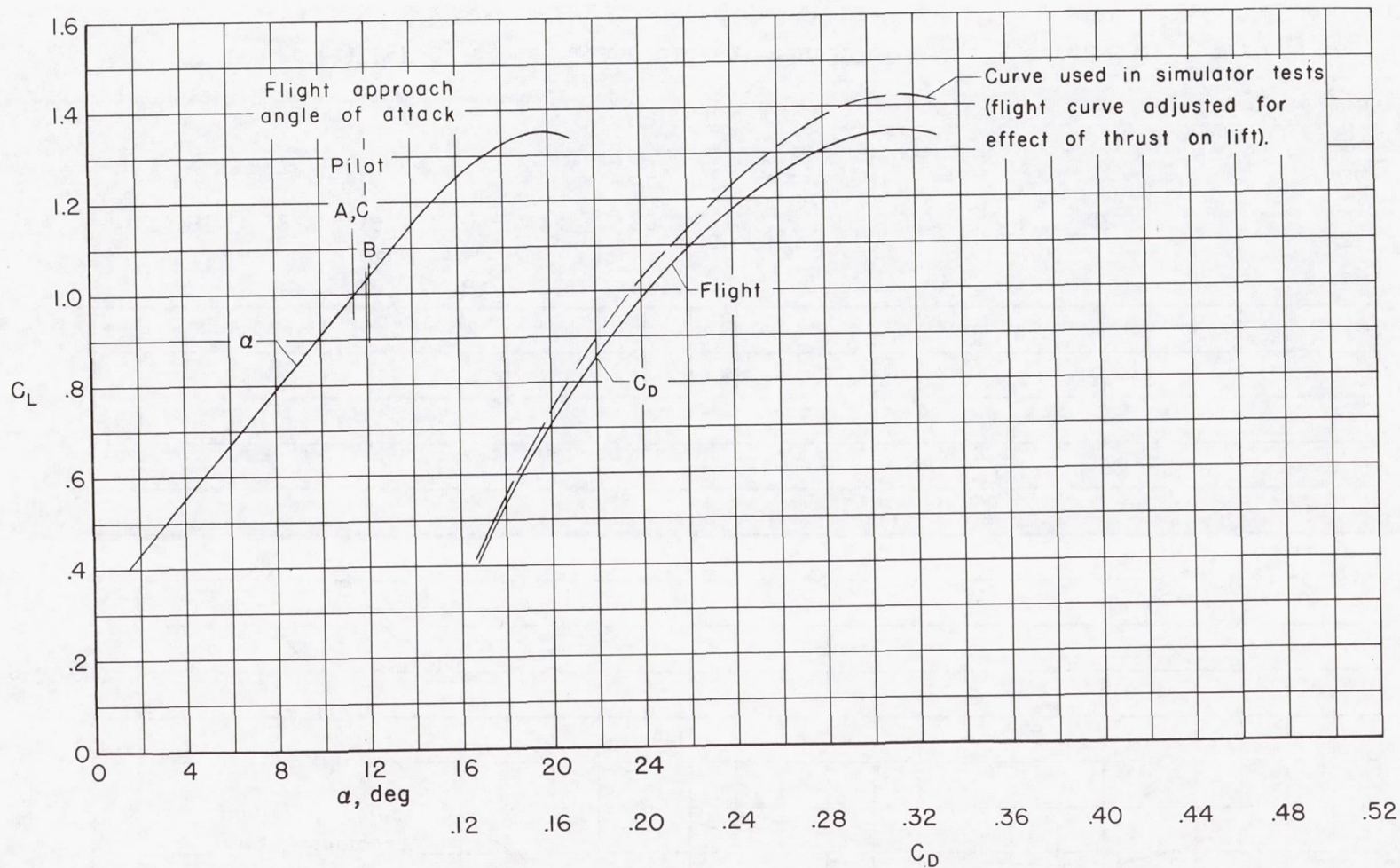

(d) FJ3; speed brakes closed; center of gravity at $0.235 \bar{c}$.

Figure 9.- Concluded.

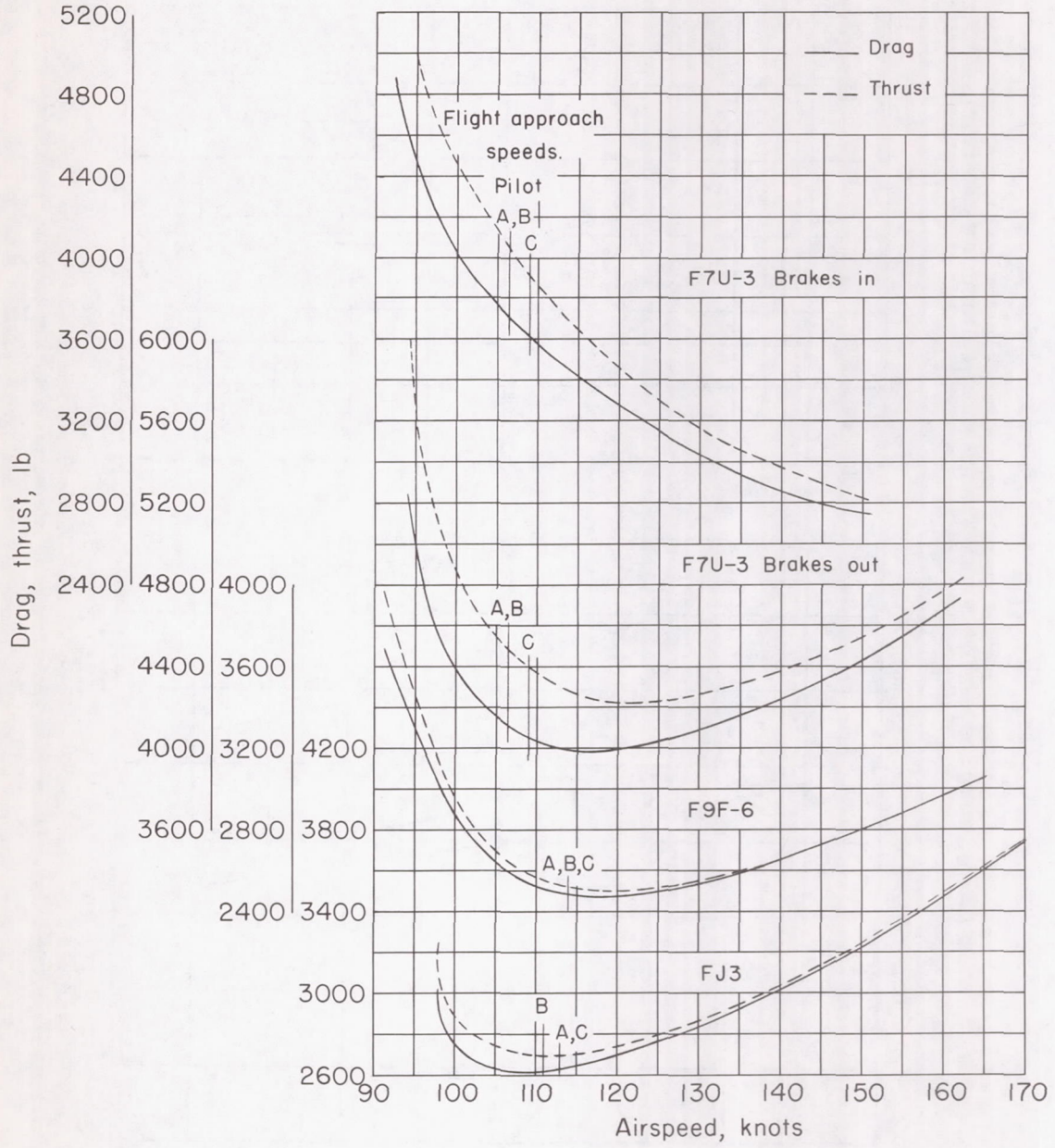
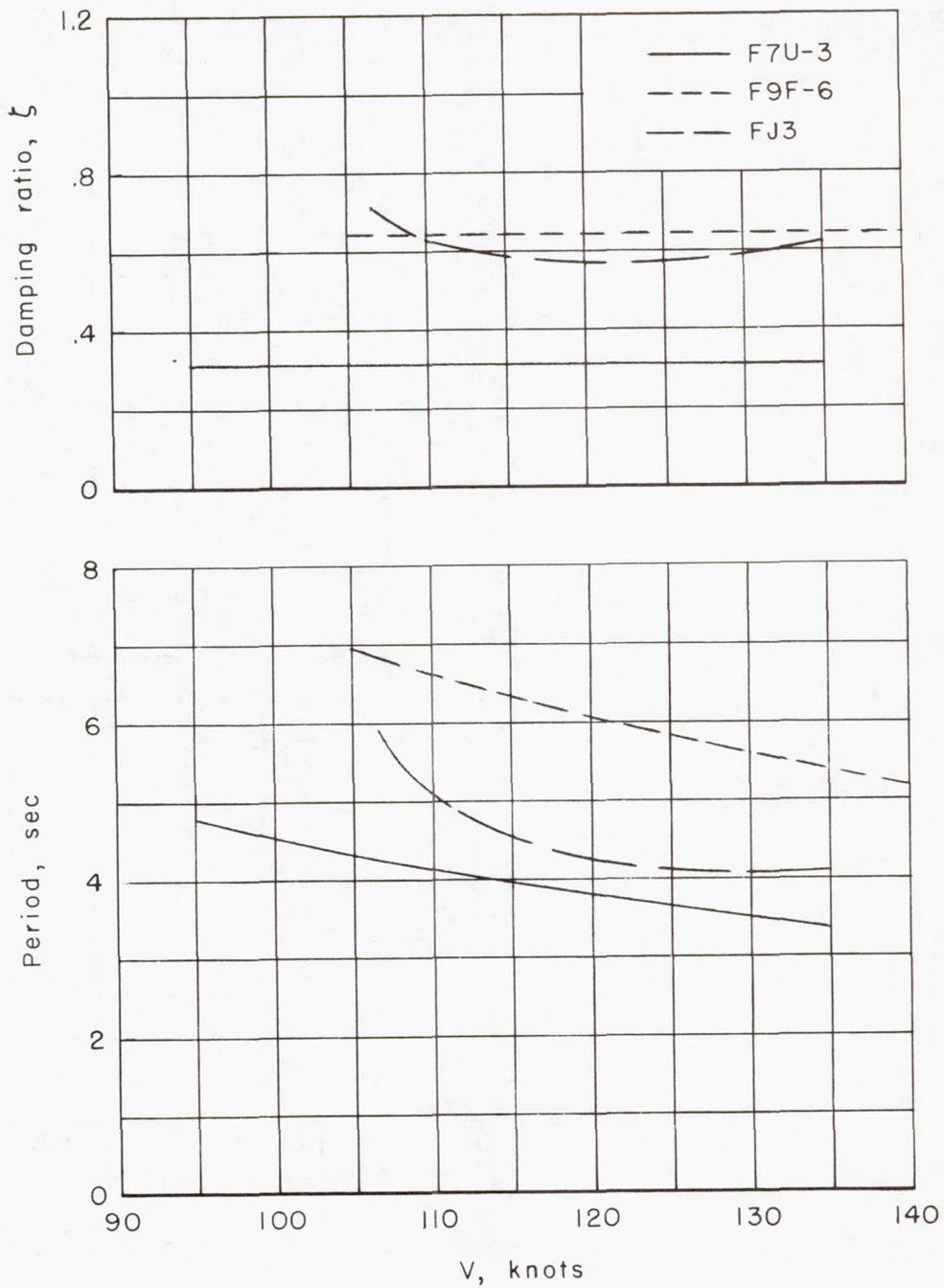
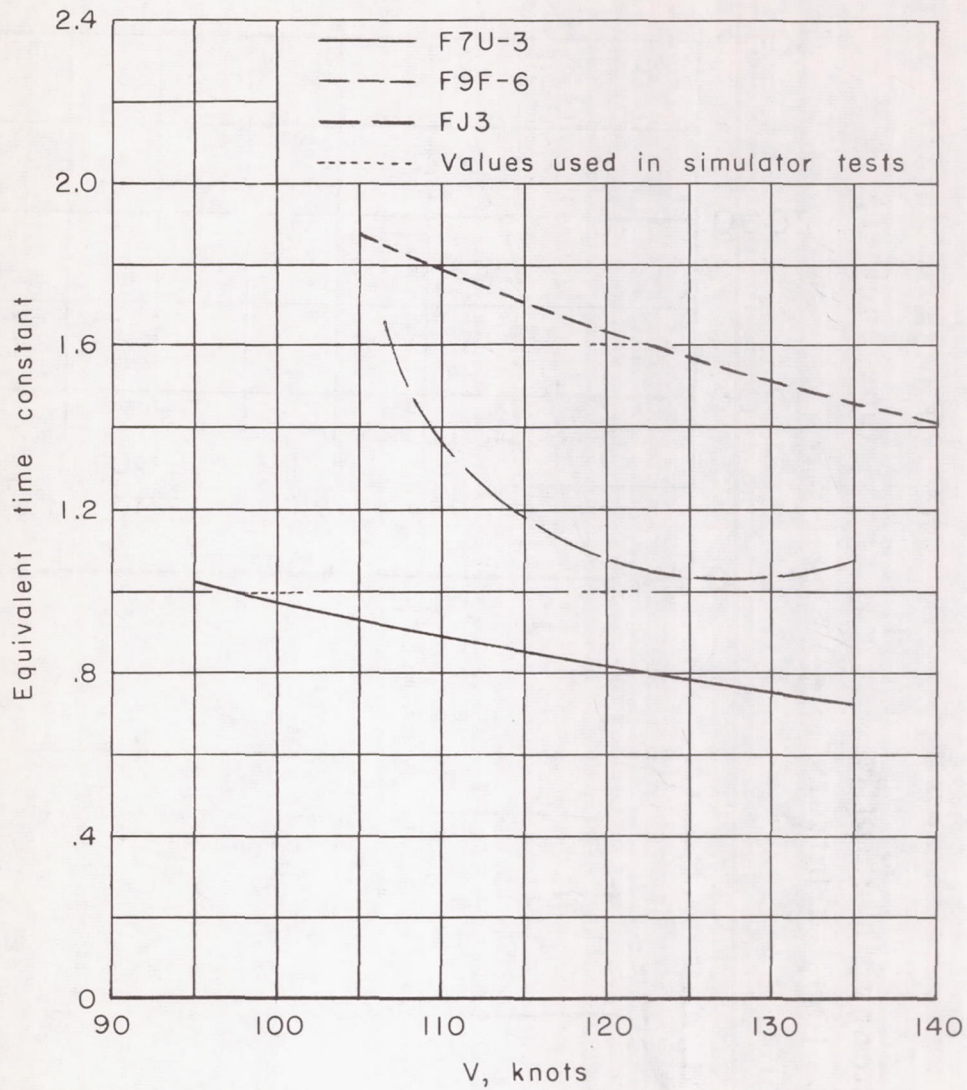

Figure 10.- Variation with airspeed of airplane drag and of engine thrust required for level flight.



(a) Flight-test results.

Figure 11.- Short-period dynamic longitudinal stability characteristics of test airplanes.



(b) Equivalent time constants for first-order system approximations to dynamic stability.

Figure 11.- Concluded.

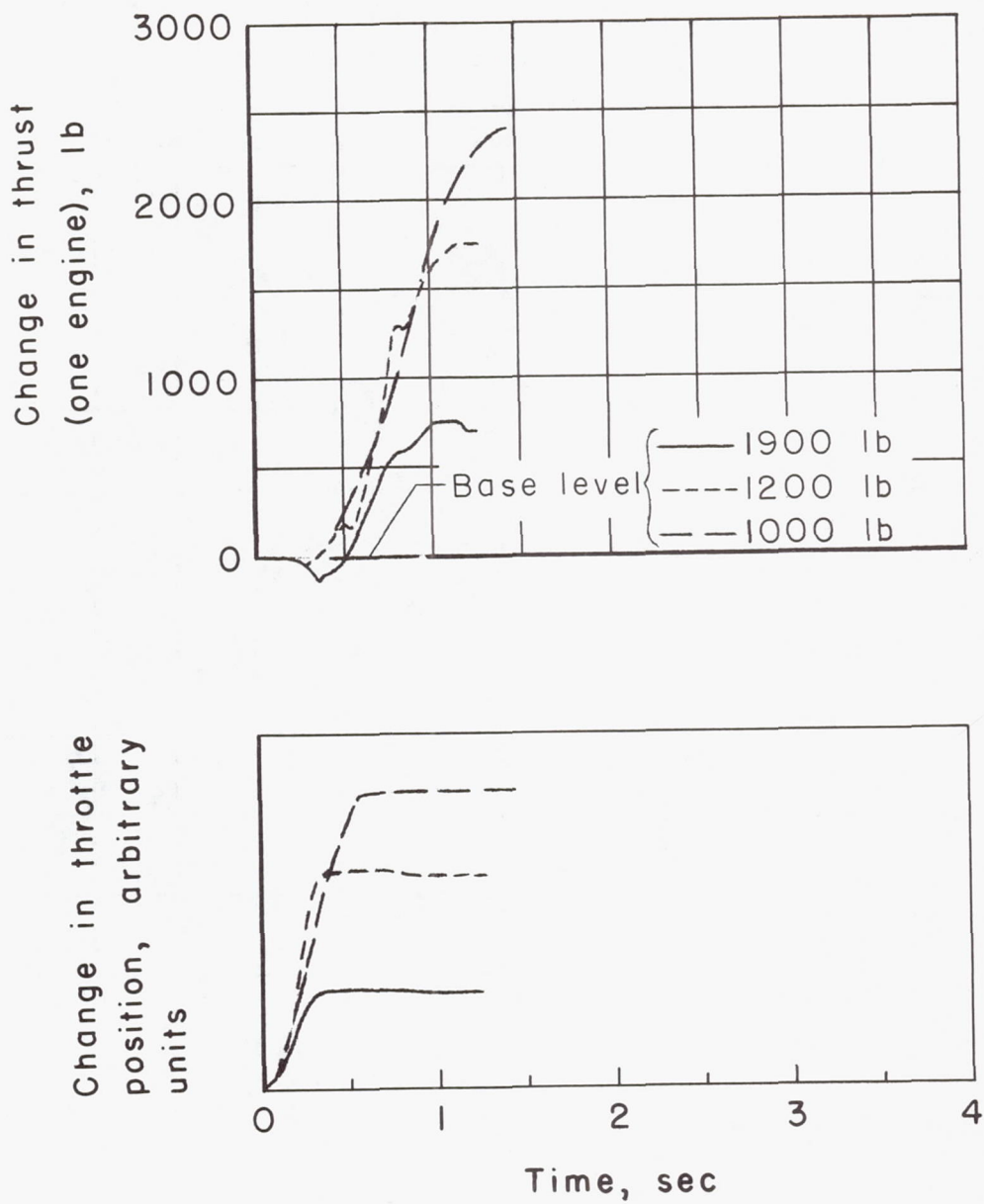

(a) F7U-3 airplane; $V = 115$ knots.

Figure 12.- Typical responses to throttle movements as determined from flight tests.

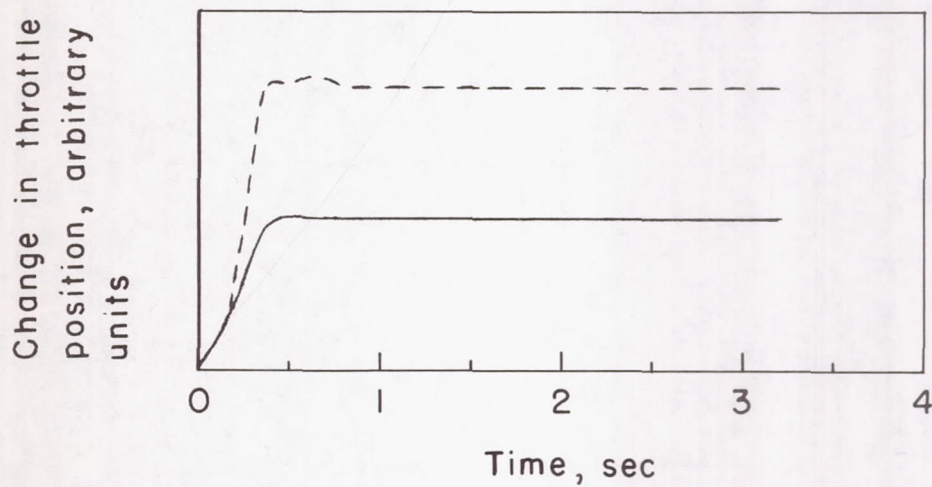
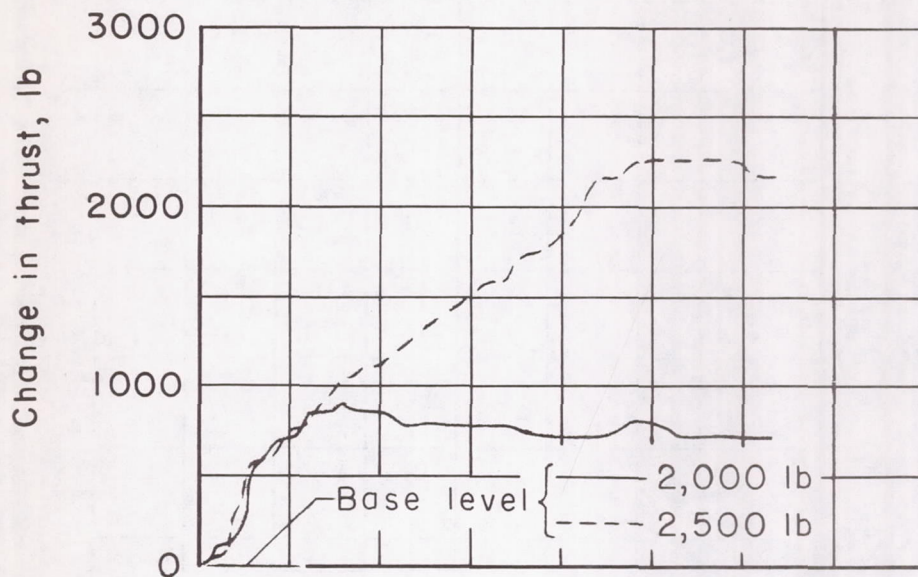

(b) F9F-6 airplane; $V = 110$ knots.

Figure 12.- Continued.

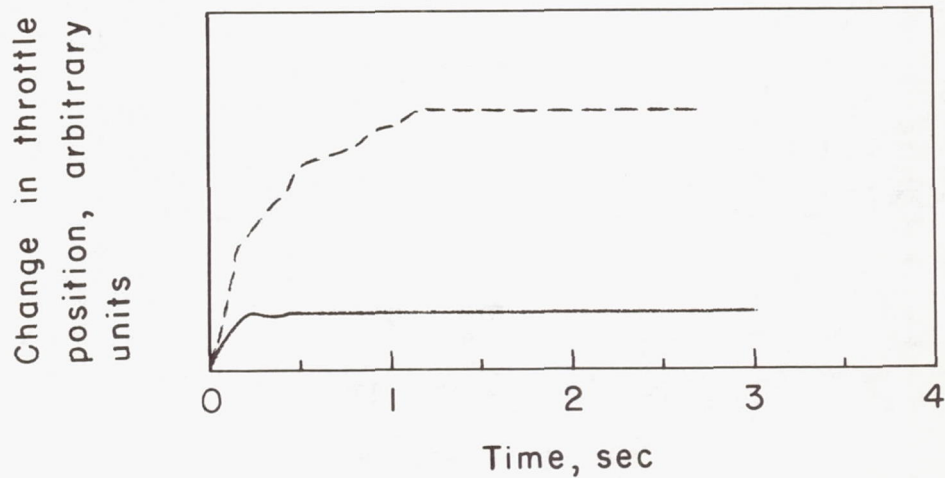
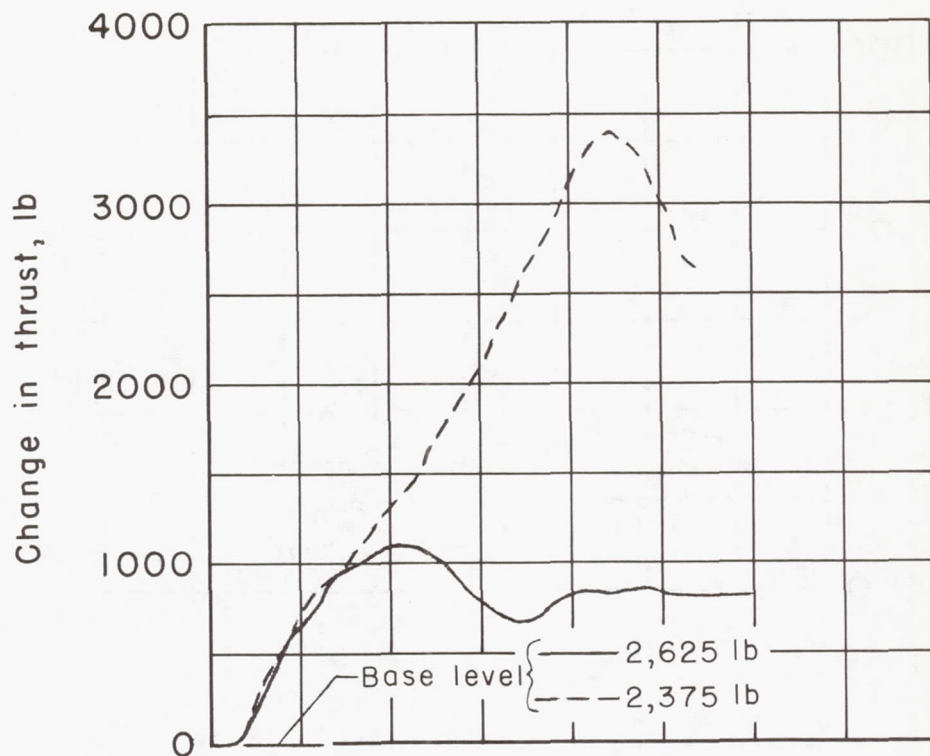

(c) FJ3 airplane; $V = 110$ knots.

Figure 12.- Concluded.

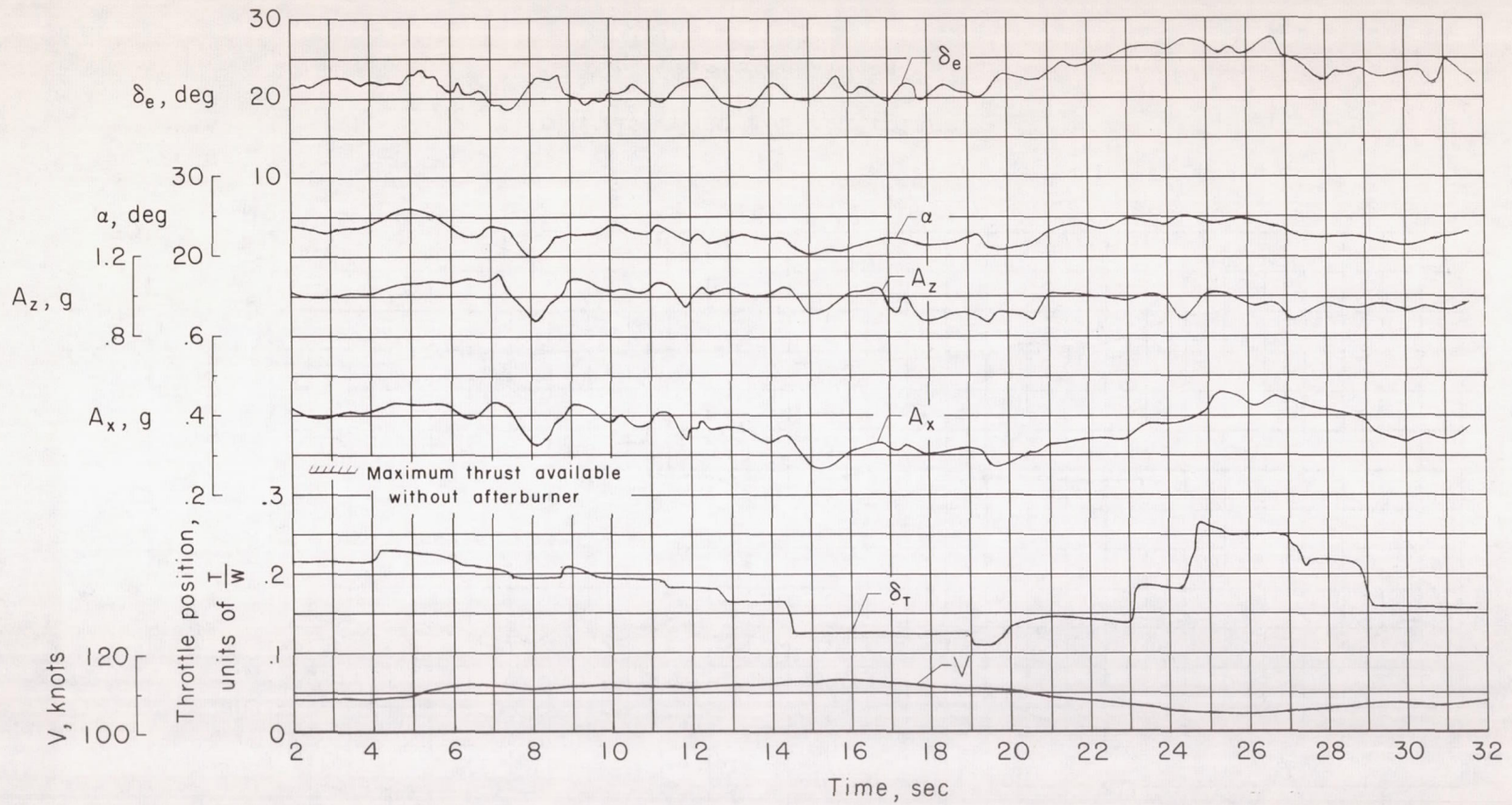

(a) Pilot B in F7U-3 airplane; brakes in.

Figure 13.- Time histories of typical landing approaches in flight.

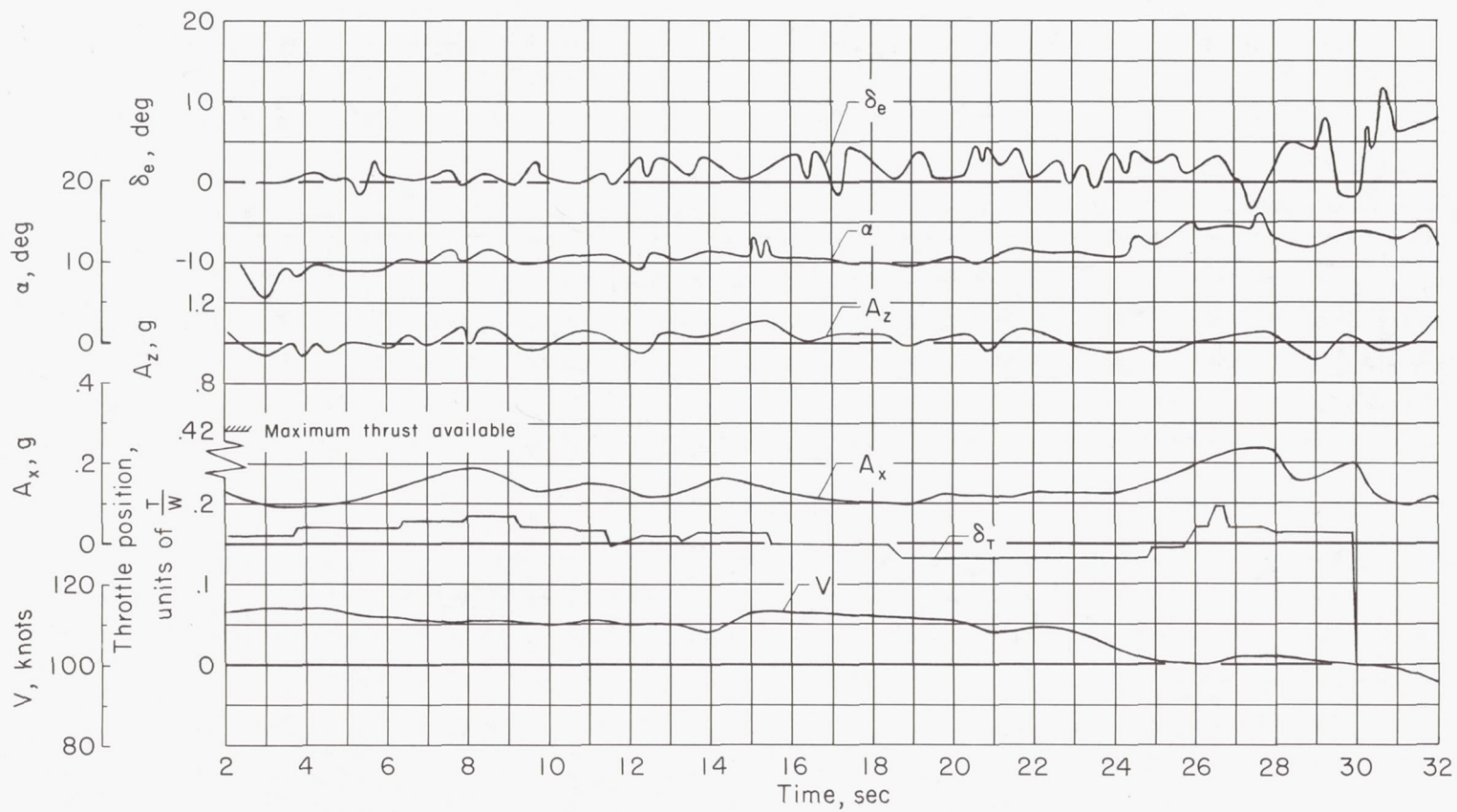

(b) Pilot A in F9F-6 airplane.

Figure 13.- Concluded.

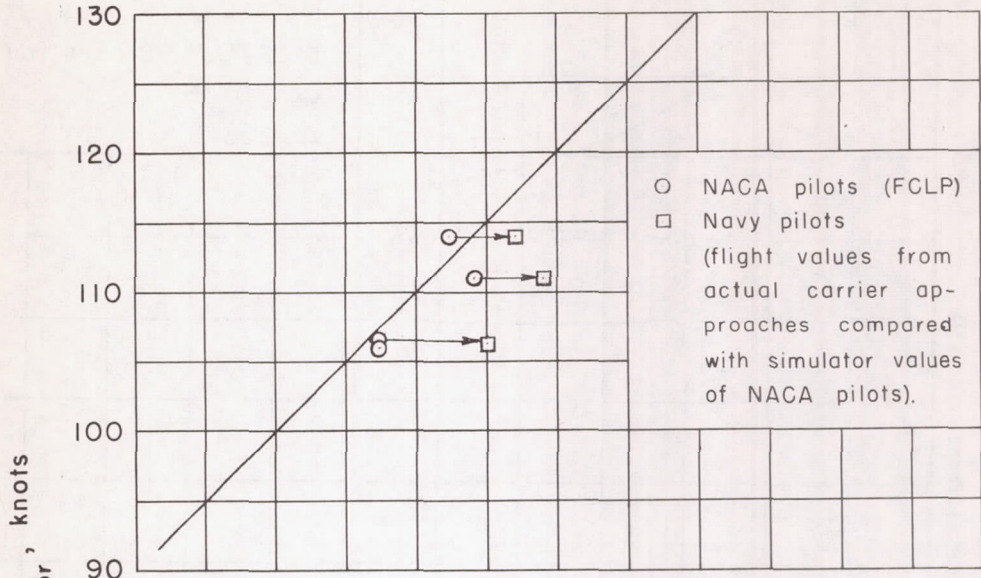

(a) Average values for NACA and Navy pilots.

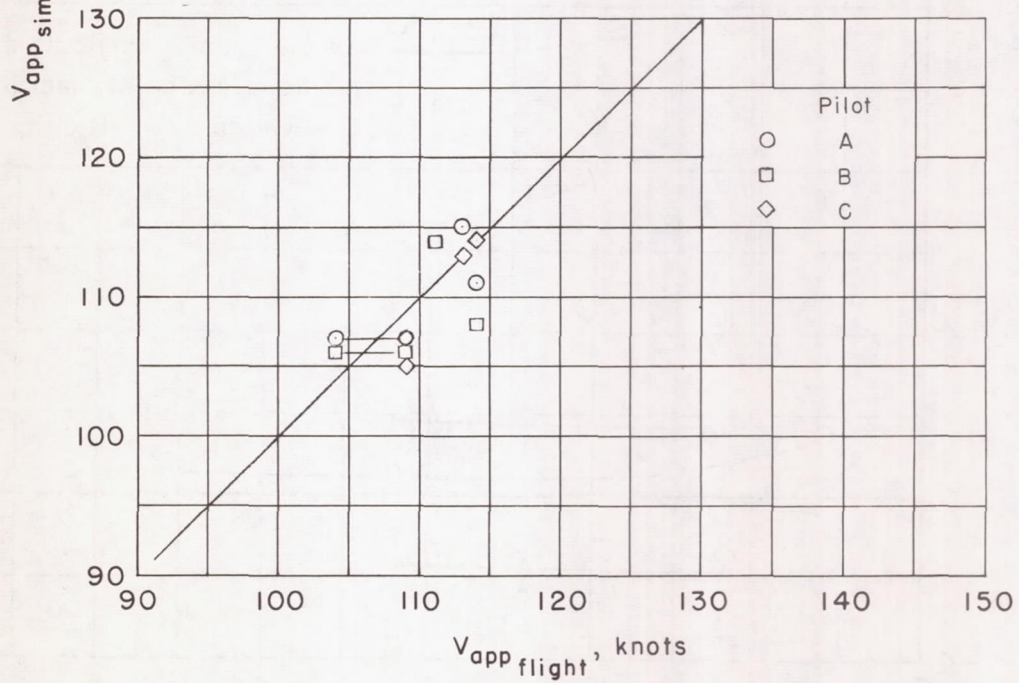

(b) Individual values for NACA pilots.

Figure 14.- Comparison of carrier approach speeds determined from flight and from simulator tests.

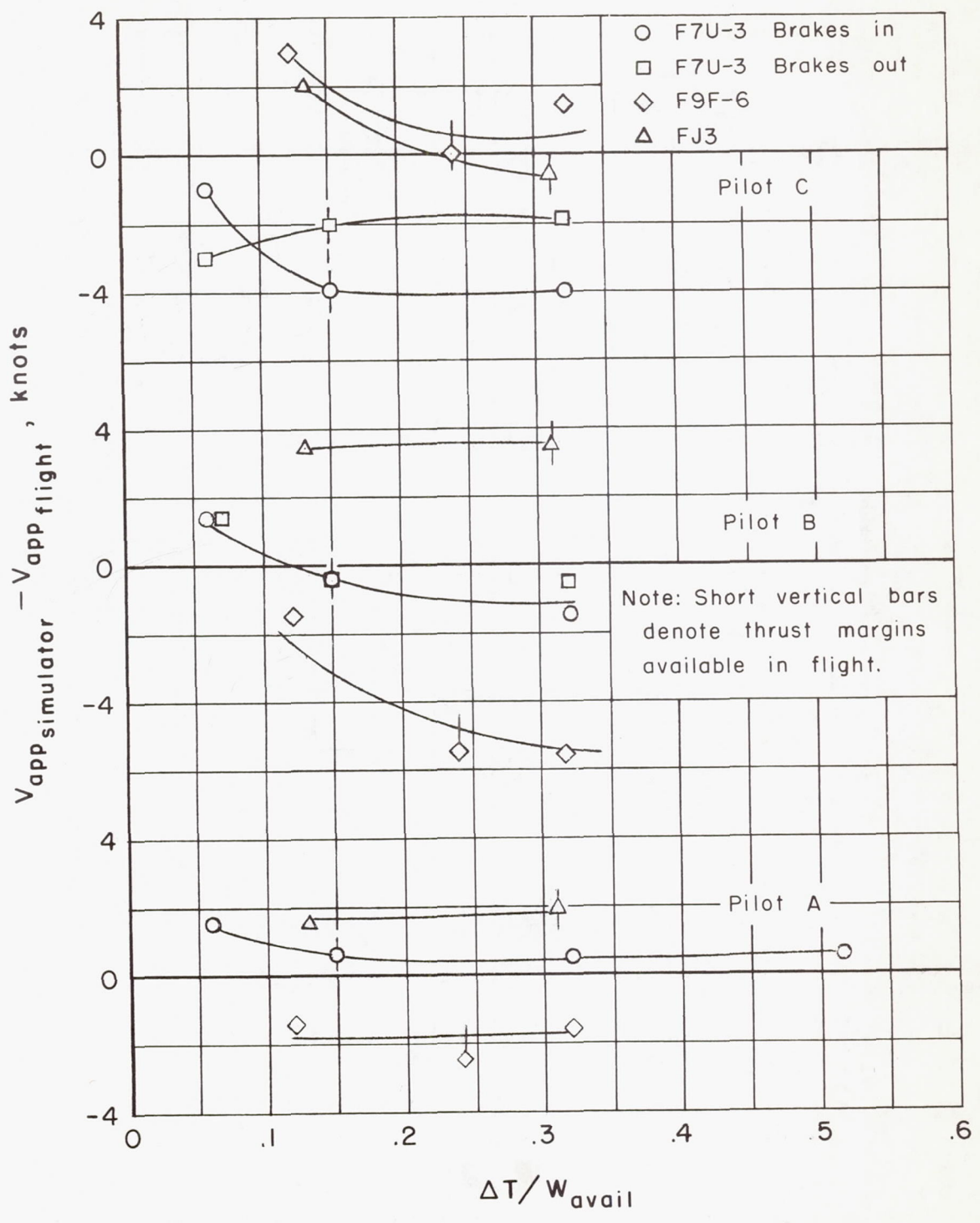

Figure 15.- Effect of available thrust margin on approach speed.