

RESEARCH MEMORANDUM

EFFECTS OF CANARDS ON AIRPLANE

PERFORMANCE AND STABILITY

By Charles F. Hall and John W. Boyd

Ames Aeronautical Laboratory
Moffett Field, Calif.

Declassified April 23, 1962

**NATIONAL ADVISORY COMMITTEE
FOR AERONAUTICS**

WASHINGTON

July 7, 1958

NATIONAL ADVISORY COMMITTEE FOR AERONAUTICS

RESEARCH MEMORANDUM

EFFECTS OF CANARDS ON AIRPLANE

PERFORMANCE AND STABILITY

By Charles F. Hall and John W. Boyd

INTRODUCTION

In considering the use of a canard in preference to a trailing-edge flap or tail control, the designer may ask the following questions: (1) What is its effect on lift-drag ratio and maximum trim lift at cruise and high-speed flight? (2) Is the control effective throughout the Mach number range and will it trim the airplane to a sufficiently high lift in the landing and take-off attitude? (3) Will the control affect adversely the longitudinal and lateral stability of the configuration? (4) What effect will the configuration variables have on the answers to these questions? To answer these questions an extensive investigation has been conducted at the Ames and Langley laboratories during the past year on canard airplane configurations.

Wide ranges in control plan form, size, and position and in wing plan form have been examined, as shown in figure 1. Also shown in figure 1 are several trailing-edge flap and tail-aft arrangements which have been used for comparison purposes in discussing the various characteristics of the canards. In addition to plan-form effects, experimental investigations of the effects of canard height with respect to the wing and body and of wing height with respect to the body have been made on several of the configurations in figure 1. Various arrangements of vertical tails and ventral fins in combination with canard controls have also been studied experimentally.

It is beyond the scope of this paper to discuss in detail the characteristics of the many configurations shown in figure 1. The purpose of this paper is to give an over-all picture of canard characteristics, stressing those characteristics which make the canard either a desirable or an impractical control, and to select data for configurations of figure 1 which are illustrative of these trends. More detailed information on the configuration characteristics can be found in references 1 to 13.

An obvious advantage of canard controls over control-aft arrangements stems from the present-day trends in high-speed aircraft, that is,

an increase in the fineness ratio of the body, a rearward movement of the center of gravity as the engines are brought closer to the fuselage base, and a corresponding rearward movement of the wing with respect to the body. Such trends permit the distance from the control to the center of gravity to be larger in general for the canard than for the aft control arrangement. This geometric advantage permits the control size, force, and hence drag to be less for a canard than for an aft control. Thus, in comparing the trim characteristics of canard and aft control arrangements it should be realized that any advantage of the former over the latter control can result from this geometric advantage. Nevertheless, the comparisons to be made subsequently are considered valid and worthwhile because many of the configurations shown in figure 1 represent actual airplanes presently used by the Air Force or are very similar to proposed airplanes.

SYMBOLS

\bar{c}	wing mean aerodynamic chord
$C_{L\alpha}$	lift-curve slope of wing, body, and fixed control
$(C_{L\delta})_C$	control lift effectiveness
C_m	pitching-moment coefficient
C_{m_0}	pitching-moment coefficient at zero lift
ΔC_m	incremental pitching-moment coefficient
ΔC_n	incremental yawing-moment coefficient
$\left(\frac{L}{D}\right)_{\max_{TR}}$	maximum lift-drag ratio at trim
$\left(\frac{L}{D}\right)_{\max_{WB}}$	maximum lift-drag ratio of wing body
l_C	effective control length, negative for forward controls, in terms of \bar{c}
M	Mach number
m	longitudinal static-stability margin of complete configuration, in terms of \bar{c}

S	wing area
S _C	control area
δ _{TR}	control deflection at trim
α _{TR}	angle of attack at trim

PERFORMANCE

Before discussing the experimental trim-drag characteristics of canard and control-aft arrangements a few simplifying concepts will be considered to determine whether one type of control has certain characteristics which make it superior to the other type and to provide orientation for the experimental data. Figure 2 represents a wing with either a canard or aft control arrangement. The normal forces on these surfaces for trim and stability are indicated as follows: N is the force on the wing, N_α the control force due to angle of attack, N_δ the control force due to control deflection, and N_i the force on the wing due to canard interference. The center of gravity must be located to assure static stability; that is, it must be ahead of the resultant of N and N_α. For the canard the single case is shown in which δ/α is equal to or greater than 0. For the aft control two cases are important, that in which δ/α is between 0 and -1 and that in which δ/α is less than -1; in the first case the control is positively inclined to the free stream and in the second case it is negatively inclined. The significance of δ/α can also be shown by expressing it in terms of other aerodynamic parameters. If these parameters vary linearly with angle of attack and control deflection then,

$$\frac{\delta_{TR}}{\alpha_{TR}} = - \frac{mC_{L\alpha} - C_{m0}/\alpha_{TR}}{l_C(C_{L\delta})_C}$$

Considering first the canard arrangement, figure 2 shows that the canard carries positive lift to balance the wing lift, a beneficial effect. However, the drag component of this lift is greater than that of a comparable lift carried by the wing because of the greater inclination of the force vector to the free stream. When the zero-lift drag of the control is added to the drag due to lift it is seen that the drag of the trimmed wing is higher than that of the untrimmed wing. It is also seen that this difference in drag increases as δ/α increases because of the greater inclination of the force vector. The diagram shows that the horizontal component of N_i is in the thrust direction.

However, this thrust is always smaller than the drag increase resulting from the increase in wing angle of attack to compensate for the loss in lift due to interference, and thus canard-wing interference results in a net drag increase.

Considering the wing and aft control with δ/α between 0 and -1 and with the center of gravity behind the wing center of pressure, the diagram shows that the control carries positive lift, which is a beneficial effect. This lift will have a drag component because of its rearward inclination, but the diagram cannot present a clear-cut comparison of this drag increment with that which would occur if the wing were carrying this lift. Nevertheless, when the zero-lift drag of the control is considered it is probable that the drag of the trimmed wing is higher than that of the untrimmed wing. Furthermore, as with the canard arrangement, interference between the wing and aft control increases the trim drag. An increase in downwash from the wing necessitates a clockwise rotation of the control from the position shown in figure 2 to obtain the same normal force, and hence an increase in the horizontal component of the force.

For the second case of a wing having an aft control wherein δ/α is between 0 and -1, the center of gravity is ahead of the wing center of pressure. The control thus carries a negative lift to balance, which is an adverse effect. Due to a large downwash from the wing the control force is inclined into the free stream so that a thrust exists, which is a favorable effect. The thrust is smaller, however, than the drag increase resulting from the increase in wing angle of attack to compensate for the negative lift on the control. When the zero-lift drag of the control is considered it is seen that the drag of the trimmed wing is greater than that of the untrimmed wing. Nevertheless, it is seen that for δ/α between zero and -1 the trim drag can be small either because the control is carrying positive lift, as in the first case, or because the negative lift has a horizontal component in the thrust direction, as in the second case.

In the last case, for δ/α less than -1, the control force is down to balance the wing lift and its horizontal component is in the drag direction. Both effects are adverse, and therefore the trim drag is high. Furthermore, as δ/α becomes more negative the inclination of the force vector to the free stream increases, and thus causes an increase in trim drag.

It is evident that the simplified force diagrams of figure 2 do not show which is the better control. They show that the trim drag is reduced as δ/α reduces toward zero for the canard and increases towards -1 for the aft control because of a reduction in the inclination of the force vector, and they serve to aid in the analysis of the data.

Therefore they will be applied to a comparison of the trim drag for canard and aft-control arrangements.

The trim characteristics of an unswept wing having either a canard, an inline tail, or a high tail are compared in figure 3. The center of gravity for each configuration is set so that the minimum static stability occurring in either the subsonic or the supersonic speed range is comparable for all configurations. For the canard and inline-tail arrangements, the results show that the absolute value of δ/α was greater than 1 in each case so that the forces are as indicated on the left side and right side of figure 2. The results for a Mach number of 1.3 show that the trim drag of the canard was slightly less than that of the tail even though the absolute values of δ/α were approximately the same. Possibly of greater importance is the effect of Mach number on the characteristics. The wing is the same in each case, its center of pressure moves aft and for each control the lift-curve slope reduces with Mach number. Both effects tend to increase the absolute value of δ/α and hence to increase the trim drag. However, the center of lift on the canard and the associated interference lift on the body move forward with increasing Mach number. This movement tends to reduce the required control force and, hence, the deflection, so that δ/α is essentially constant in the Mach number range of figure 3. In general this forward movement of the center of pressure with increasing Mach number between Mach numbers of 1 and 2 has been characteristic of the canard configurations investigated, and in the case illustrated in figure 3 amounted to 15 percent of the control length. Furthermore, a significant reduction in the interference lift with increasing supersonic Mach number resulted in the increase in the ratio of trim-lift drag to wing-body lift drag. This reduction in interference with Mach number has also been characteristic of the various canards investigated. On the other hand, for the inline-tail configuration no effect existed to compensate for the rearward travel of the wing center of pressure and the decreasing control lift-curve slope with increasing Mach number, and therefore the control force and negative deflection increased. Furthermore, the wing downwash decreased with Mach number so that the negative deflection of the control was increased to maintain an equal force. From the force diagram on the right of figure 2 it is evident that increasing the download and negative deflection results in an increase in the drag component of the control force and hence an increase in trim drag.

It should be mentioned that in both cases the trim drag could be reduced if at subsonic speeds artificial stability devices were used, or if the canard were permitted to free-float so that the center of gravity could be moved closer to the wing center of pressure and the value of δ/α for trim could be reduced. Nevertheless, the relative effects of increasing supersonic Mach number would be the same.

The adverse effects of Mach number for the inline tail are not necessarily characteristic of an aft control arrangement, as indicated by the results for the high tail. The data show that for the high-tail arrangement δ/α was between 0 and -1, and therefore the control forces are as indicated by the lower center diagram of figure 2. The low value of δ/α resulted from two factors. First, the control drag produced a positive trimming moment and thus reduced the normal force required for trim. This effect would also reduce the canard trim drag if the canard were moved above the center of gravity by negatively cambering the body, as has been done on several of the configurations shown in figure 1. Second, interference between the vertical and horizontal tails induced a download on the tail with no corresponding increase in negative deflection. The results show that the effect of Mach number was favorable for the high-tail arrangement. This favorable effect resulted from the fact that the downwash from the wing in the vicinity of the tail increased between Mach numbers of 1.3 and 2. Thus the inclination of the tail to the free stream was increased to maintain an equal load and the result was a greater thrust component of the control force and, hence, less trim drag. This favorable effect of Mach number on the high-tail characteristics is determined by the location of the tail with respect to the shock waves from the leading and trailing edges of the wing. When the horizontal tail is outside of the region bounded by these two shock waves the downwash from the wing is small and therefore δ/α is more negative and the trim drag is greater than shown in figure 3 for a Mach number of 2. Thus, these favorable effects of Mach number will disappear at some higher Mach number where the shock wave from the wing leading edge is depressed below the horizontal tail. Also, raising the horizontal tail or moving it forward will lower the range of Mach numbers in which this favorable effect is present. Although the characteristics of the high-tail arrangement shown in figure 3 are very desirable it should be mentioned that these benefits of a high tail may be outweighed by longitudinal-stability and structural problems associated with the arrangement.

Another comparison of the trim-drag characteristics of canard and aft control arrangements is made in figure 4, in which results for a canard and a trailing-edge flap in combination with a triangular wing (configurations 1 and 15) are shown. At low supersonic Mach numbers the absolute value of δ/α was greater for the canard than for the trailing-edge flap as a result of lower control effectiveness for the canard configuration; the trim drag of the canard configuration was therefore higher. With increasing Mach number the canard became considerably superior to the trailing-edge flap, partly because of the beneficial characteristics mentioned in conjunction with the unswept wing and canard arrangement of figure 3, that is, a forward movement of the center of pressure due to canard lift and its associated interference lift on the body and a reduction in canard-wing lift interference.

In addition to the aforementioned favorable effects of Mach number on the trim-drag characteristics of canard configurations with either unswept or triangular wings, another favorable characteristic was present in the case of the triangular wing which was primarily responsible for its more impressive beneficial effects with increasing Mach number. This additional beneficial effect was the large forward movement of the wing and body center of pressure with increasing Mach number, as indicated in figure 5. The position of the center of pressure is expressed as a percentage of the mean aerodynamic chord of the respective wing, and thus the large differences in the characteristics of the triangular and the unswept wing are due in part to the fact that the mean aerodynamic chord of the former wing is approximately $1\frac{1}{2}$ times that of the latter wing for the same area. Nevertheless, even accounting for these differences, the results of figure 5 indicate that the maximum rearward travel of the center of pressure between subsonic and supersonic speeds was less and the forward movement of the center of pressure with increasing supersonic Mach number was faster for the triangular wing than for the unswept wing. The forward movement of the center of pressure of the triangular wing and body, coupled with the aforementioned forward shift of the center of pressure of lift due to the canard as supersonic Mach number increased, caused the center of pressure of the triangular wing with canard to be the same at a Mach number of 3.4 as at a Mach number of 0.7. The data thus raise the interesting possibility that the position of the center of gravity for a triangular wing and canard arrangement similar to this may be dictated by characteristics at Mach numbers above approximately 3.5 rather than at subsonic speeds.

Returning to trim-drag characteristics of canard and aft control arrangements, figure 6 presents the results for many of the configurations of figure 1 in order to show general trends. The two diagonal lines are symmetrical about a value of δ/α of zero and are drawn to aid in the comparison of the general trends of canard and aft control configurations. In general the data for the aft control arrangements lie near the diagonal line, whereas those for the canard arrangements are above the line, indicating that for the same absolute value of δ/α the canard trim drag will in general be less. As before, the results show that the trim drag of inline-tail arrangements increased with Mach number (configurations 15, 16, and 18) whereas the trim drag decreased with increasing Mach number for high-tail arrangements (configurations 19 and 20). Also (as for configuration 1 in fig. 4) the trim drag of configuration 2 (a triangular wing and canard) decreased considerably with increasing Mach number between Mach numbers of 1.3 and 2. Configurations 1 and 2 are the same except that the distance from the control to the wing is larger in the latter case and the control effectiveness is therefore larger. Comparison of the data for these configurations in

figure 6 shows that increasing the distance between control and wing is an effective way of reducing δ/α and, hence, trim drag. Within limits, another effective way of increasing the control effectiveness and thereby reducing δ/α and the trim drag is to increase the control area, as indicated by the results for configurations 7, 8, and 9, in which the exposed area of the control was increased from 5.1 percent to 7.6 percent of the wing area.

Beneficial effects of the canard on maximum trim lift-drag ratio also extended to higher lifts, as shown in figure 7. The configurations compared are the same as those in figures 3 and 4. It will be noted that the lift-drag ratios for these configurations are lower than those obtained for other configurations tested at Mach numbers as high as 3.0. These lower ratios are due in part to the fact that in the present case the body volume is considerably larger relative to the wing than in those previous cases. The body size should not affect significantly the comparisons shown herein. More impressive than the drag characteristics is the large increase in maximum trim lift, which was as much as 60 percent greater for the canard than for the aft control arrangement, even though the maximum control deflection was the same in both cases. More than half of this beneficial effect of the canard was due to the fact that the canard had a large positive lift and the canard-wing interference lift was small, whereas a negative lift existed on the aft control.

STABILITY AND CONTROL

In view of the beneficial effects of canard arrangements on lift-drag characteristics, it is advisable to investigate other aspects of canards, such as their control effectiveness and their effect on longitudinal and lateral stability. Figure 8 presents the lift-curve slope with respect to angle of attack and control deflection for various plan forms as obtained experimentally and theoretically. The theoretical methods were those discussed in reference 14. The experimental results from which the derivatives were obtained were essentially linear in the angle-of-attack and control-deflection ranges up to 10° . The comparison indicates that the theory is adequate for predicting the effects of plan form on lift, such as reduced lift with increasing supersonic Mach number, increasing leading-edge sweep, and decreasing aspect ratio. These data were obtained from the differences between canard-body data and body-alone data in order to eliminate canard-wing interference. They contain the mutual interference between canard and body, however, which in this angle-of-attack and deflection range was favorable, as predicted by theory. At higher angles of attack the effect of interference between the canard and body was such as to suppress the body

lift resulting from viscous cross flow and, to a smaller extent, the potential lift. Thus at angles of attack near 16° the interference lift on the body was negative, as indicated by a comparison of values for body lift with and without the canard and the measured lift on the canard in the presence of the body. That is, at high angle of attack the canard reduced the lift on the body.

At subsonic speeds an important characteristic of canard arrangements is the maximum lift effectiveness in the presence of a ground plane, and this characteristic is shown in figure 9. The curves labeled "required" are the pitching moment necessary to trim the triangular wing and body combination at various heights above the ground plane. The results indicate a considerable increase in pitching moment and lift at a constant angle of attack; that is, the ground induced a lift on the aft portions of the wing as the wing and body approached the ground. The maximum available trimming moment of the canard, as shown in figure 9, was obtained from an envelope of data for various angles of attack and control deflections. As might be expected, the ground plane did not affect the maximum available trimming moment since the height of the canard above the ground, expressed in terms of its own chord, was considerably greater than that of the wing. Thus, as a result of the large influence of the ground on the wing-body characteristics and the lack of a corresponding influence on the canard, the maximum trimmed lift coefficient for this configuration was reduced approximately 0.2, or 18 percent, as it reached a distance of 0.6 of the wing mean aerodynamic chord above the ground.

Since the ground plane had no effect on the canard characteristics, the effects of canard plan form on the maximum available pitching moment required for trim can be obtained in the absence of a ground plane. Such data have been obtained for canards of various aspect ratio, taper ratio, and sweep, and are shown in figure 10. For these data the exposed canard area and the distance from the control to the center of gravity of the wing are the same in each case. In general the results indicate an increase in maximum pitching moment available for trim with increasing leading-edge sweep or decreasing aspect ratio, or combinations thereof. This is just opposite to the effect of these parameters on the lift effectiveness. For canards, an increase in lift effectiveness produces a destabilizing contribution at low angles of attack. Thus, if it were desired to use one of these canards of higher aspect ratio and lower sweep in combination with the wing-body configuration of figure 9, it would be necessary to increase the stability of the wing-body combination by forward movement of the center of gravity to offset the increased destabilizing moment of the canard. Thus, increasing the aspect ratio or reducing the sweep of the canard has the double deleterious effect on maximum trim-lift coefficient of reducing the available moment and increasing the required moment. In fact, for the triangular wing and

body of figure 9 in combination with either a triangular or an unswept canard, both configurations having the same static margin, the maximum trim lift of the unswept canard arrangement was only about 1/2 of that for the triangular canard configuration.

Interference effects between the canard and the wing or vertical tail may be sufficiently large to prohibit the use of a canard arrangement, and therefore it is necessary to examine these effects. The lift interference between the canard and wing affects primarily the lift-drag characteristics and is shown in figure 11. The experimental data were obtained from the difference in the incremental lifts due to addition of canard to the body in the presence of the wing and in the absence of the wing. The theoretical results are based on the assumption that a vortex originates at the trailing edge of each canard panel and these vortices stream rearward over the wing, altering the flow in the vicinity of the wing and hence the lift on the wing. The spanwise origin of these vortices is determined in the manner presented in reference 14. In this method the spanwise loading on the exposed canard panel must be known. In the present calculations the assumption was made that at $\alpha = 0^\circ$, the span loading was as given by the linear theory, and that it changed with increasing angle of attack until, at $\alpha = 30^\circ$, it had the same shape as the canard plan form. Thus, for the triangular canard with subsonic leading edges the vortex is located at $\pi/4$ of the exposed semispan at $\alpha=0^\circ$ and 1/2 of the exposed semispan at $\alpha=30^\circ$. It is next assumed that the vortex flows in the free-stream direction from the canard trailing edge to the wing shock wave, where it is deflected downward by the wing downwash field. The downwash field above the wing was determined by the methods of reference 15. The strength of the vortex is determined from the theoretical lift on the exposed canard panel, which includes interference from the body, and the spanwise distance from the body to the vortex at the canard trailing edge. The strength and position of the vortex in the vicinity of the wing are used to determine its influence on the wing lift by means of strip theory. In this method the lift induced by the vortex at any wing section is the product of the angle of attack induced by a two-dimensional vortex and the section lift-curve slope (assumed to be equal to the two-dimensional value $4/\beta$). The results of figure 11 show that the trends of the canard-wing lift interference with increasing Mach number are predictable. The agreement is not entirely satisfactory, however, and studies are continuing to determine the cause of the discrepancies.

The pitching-moment interference between the canard and wing shown in figure 12 can be serious in that the stability of the configuration may be changed. Two sets of experimental data are shown in figure 12. The symbols represent data measured for the complete configuration and the dashed curves represent the condition of no wing-canard interference

as determined from tests of the separate components of the configurations. The centers of gravity were selected to provide the same static margin for all configurations at subsonic speeds, and the Mach number at which the largest interference effects occurred was used for each configuration. The theoretical results were obtained by the methods discussed for the wing-canard lift interference. The experimental and theoretical results show that for wings in which the stabilizing moment of the tip upload resulting from the upwash field of the canard is small, either because of a small tip chord in the case of triangular wings or because the tip is in line with the root chord as for the unswept wing, the interference effects are small. In the cases shown the interference effects are slightly favorable and are unaffected by angle of attack. However, for wings having a sizable tip chord swept considerably behind the center of gravity, the interference effects can be large, particularly at high control deflection and small angle of attack, and as shown in figure 12 can affect adversely the stability of the configuration. As shown, the stabilizing contribution of the upload at the tip of the sweptback wing can become significant at small angles of attack and a control deflection of 20° . However, with increasing angle of attack the tip moves below the canard-vortex field faster than the root section of the wing. This condition reduces the influence of the tip with respect to that of the root section and thus significantly reduces the stability of the configuration. At higher angles of attack, where the tip effect is small, the interference becomes favorable; that is, for the conditions shown the interference effect has increased the trim angle of attack. However, for small control deflections trim would occur in those regions of reduced stability which might be sufficiently pronounced, for highly swept wings with a sizable tip chord, to determine the center of gravity of the configuration.

Because the directional stability of high-speed aircraft may become marginal at high angles of attack at moderate supersonic Mach numbers, it is necessary to examine the interference effect of the canard on this characteristic. In order to show the relative importance of the canard interference on directional stability, in figure 13 the directional stability of the complete configuration BWVC is subdivided into the stability contributions of the vertical tail, V , the body-wing, BW , the body-wing interference on the vertical tail, V_{BW} , the canard interference on the vertical tail and body at $\delta = 0^\circ$, V_C and B_C , respectively, and the canard interference on the body and vertical tail due to canard deflection, B_δ and V_δ . The results show that the largest interference effect was that of the body-wing on the vertical tail, V_{BW} . This effect is due to an increase in the high-velocity field and a reduction in dynamic pressure in the vicinity of the vertical

tail resulting from the wing and body effects which reduced the lift-curve slope of the vertical tail (ref. 16). Calculations have shown that for this configuration approximately 80 percent of V_{BW} could be attributed to these causes.

The interference of the canard on the body, B_C , was stabilizing at high angles of attack. This effect can be traced to the aforementioned reduction in body forces near the canard due to canard interference at high angles of attack.

The interference of the canard on the vertical tail, V_C , was destabilizing throughout the angle-of-attack range for the single vertical-tail arrangement shown in figure 13. This destabilizing effect of the canard on the vertical tail results from the interference between the canard-vortex field and the vertical tail. For a configuration in sideslip the interference is such that the flow below the core of the windward-side vortex is in a destabilizing direction, whereas that for the lee side is in a stabilizing direction. Therefore, with increasing sideslip angle the vertical tail moves toward the destabilizing flow field and away from the stabilizing flow field. With increasing angle of attack the vertical tail moves down with respect to these vortex cores and the vortex strength increases. Thus more of the vertical tail is affected by a stronger flow field beneath the core and the adverse interference effect increases. It can be seen that if the vortex cores are lowered with respect to the vertical tail the destabilizing influence of the canard on the vertical tail will be reduced. At high angles of attack V_C is stabilizing since in this case the vortex core is moved downward as a result of control deflection.

The interference of the canard on the vertical tail, V_C , depends to a large extent on the vertical-tail arrangement, as shown in figure 14. The results show that, as in figure 13, the effect of the canard is destabilizing for a single-tail arrangement. However, for the twin-tail arrangement the interference of the canard on the vertical tail is stabilizing. In contrast to the single vertical tail, the twin vertical tail moved away from the destabilizing flow field beneath the windward vortex and toward the stabilizing flow field of the leeward vortex. Tests of another configuration having twin tails closer together than those of the configuration in figure 14 have indicated that the tail spacing should be at least equal to the canard span to obtain favorable interference between the canard and vertical tails.

The effects of Mach number on the directional stability of a canard configuration are presented in figure 15 in a manner similar to that of figure 13. The results show that the destabilizing influence of the canard on the vertical tail became essentially zero above a Mach number

of 2.2, whereas the stabilizing contribution due to canard interference on the body extended up to a Mach number of 3.5, the limit of the tests. In fact, it apparently was the favorable body-canard interference that maintained positive directional stability at Mach numbers above 2.5.

For all configurations investigated, canard interference made $C_{l\beta}$ (rolling moment due to sideslip) more negative; that is, it increased the dihedral effect. Since this interference results from a leeward shift of the center of the canard interference lift on the wing with increasing sideslip, the effects of Mach number and angle of attack on the interference $C_{l\beta}$ are similar to those on interference lift; that is, $C_{l\beta}$ reduces with increasing supersonic Mach number and increases with angle of attack.

CONCLUDING REMARKS

The data have indicated factors which cause the trim-drag characteristics of canard configurations to be superior to those of trailing-edge-flap and tail arrangements. The effect of plan form and control lift at low angles is predictable by theory and is opposite to the plan-form effect on the maximum available pitching moment. Interference effects between the canard and other configuration components were not serious, except possibly those which affect the directional stability, and these latter effects can be reduced by rearrangement of the vertical tail.

Ames Aeronautical Laboratory
National Advisory Committee for Aeronautics
Moffett Field, Calif., Mar. 20, 1958

REFERENCES

1. Boyd, John W., and Peterson, Victor L.: Static Stability and Control of Canard Configurations at Mach Numbers From 0.70 to 2.22 - Longitudinal Characteristics of a Triangular Wing and Canard. NACA RM A57J15, 1958.
2. Peterson, Victor L., and Menees, Gene P.: Static Stability and Control of Canard Configurations at Mach Numbers From 0.70 to 2.22 - Lateral-Directional Characteristics of a Triangular Wing and Canard. NACA RM A57L18, 1958.

3. Boyd, John W., and Peterson, Victor L.: Static Stability and Control of Canard Configurations at Mach Numbers From 0.70 to 2.22 - Triangular Wing and Canard on an Extended Body. NACA RM A57K14, 1958.
4. Peterson, Victor L., and Menees, Gene P.: Static Stability and Control of Canard Configurations at Mach Numbers From 0.70 to 2.22 - Longitudinal Characteristics of a Triangular Wing and Unswept Canard. NACA RM A57K26, 1958.
5. Peterson, Victor L., and Boyd, John W.: Static Stability and Control of Canard Configurations at Mach Numbers From 0.70 to 2.22 - Longitudinal Characteristics of an Unswept Wing and Canard. NACA RM A57K27, 1958.
6. Hedstrom, C. Ernest, Blackaby, James R., and Peterson, Victor L.: Static Stability and Control Characteristics of a Triangular Wing and Canard Configuration at Mach Numbers From 2.58 to 3.53. NACA RM A58C05. (Prospective NACA paper.)
7. Spearman, M. Leroy, and Driver, Cornelius: Effects of Canard Surface Size on Stability and Control Characteristics of Two Canard Airplane Configurations at Mach Numbers of 1.41 and 2.01. NACA RM L57L17a, 1958.
8. Spearman, M. Leroy, and Driver, Cornelius: Some Factors Affecting the Stability and Performance Characteristics of Canard Aircraft Configurations. NACA RM L58D16. (Prospective NACA paper.)
9. Driver, Cornelius: Longitudinal and Lateral Stability and Control Characteristics of Two Canard Airplane Configurations at Mach Numbers of 1.41 and 2.01. NACA RM L56L19, 1957.
10. Driver, Cornelius: Longitudinal and Lateral Stability and Control Characteristics of Various Combinations of the Component Parts of Two Canard Airplane Configurations at Mach Numbers of 1.41 and 2.01. (Prospective NACA paper.)
11. Sleeman, William C., Jr.: Investigation at High Subsonic Speeds of the Static Longitudinal and Lateral Stability Characteristics of Two Canard Airplane Configurations. NACA RM L57J08, 1957.
12. Spearman, M. Leroy, and Driver, Cornelius: Longitudinal and Lateral Stability and Control Characteristics at Mach Number 2.01 of a 60° Delta-Wing Airplane Configuration Equipped With a Canard Control and With Wing Trailing-Edge Flap Controls. NACA RM L58A20, 1958.

13. Spearman, M. Leroy: Some Factors Affecting the Static Longitudinal and Directional Stability Characteristics of Supersonic Aircraft Configurations. NACA RM L57E24a, 1957.
14. Pitts, William C., Nielsen, Jack N., and Kaattari, George E.: Lift and Center of Pressure of Wing-Body-Tail Combinations at Subsonic, Transonic, and Supersonic Speeds. NACA Rep. 1307, 1957.
15. Nielsen, Jack N., and Perkins, Edward W.: Charts for the Conical Part of the Downwash Field of Swept Wings at Supersonic Speeds. NACA TN 1780, 1948.
16. Nielsen, Jack N., and Kaattari, George E.: The Effect of Vortex and Shock-Expansion Fields on Pitch and Yaw Instabilities of Supersonic Airplanes. Preprint No. 743, S.M.F. Fund Preprint, Inst. Aero. Sci., June 1957.

CONFIGURATIONS INVESTIGATED

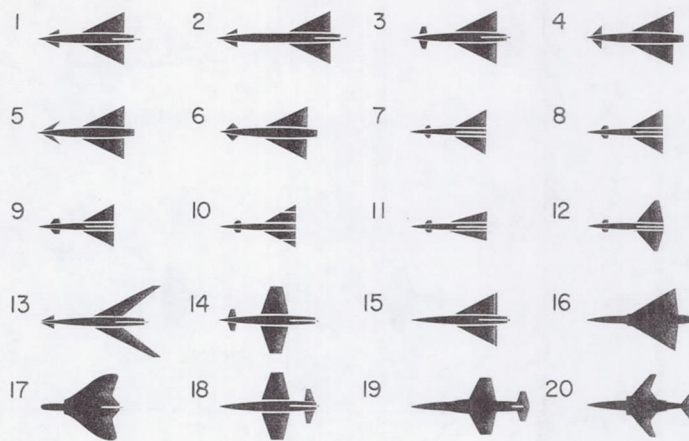

Figure 1

CANARD AND TAIL-AFT CONTROL FORCES FOR TRIM

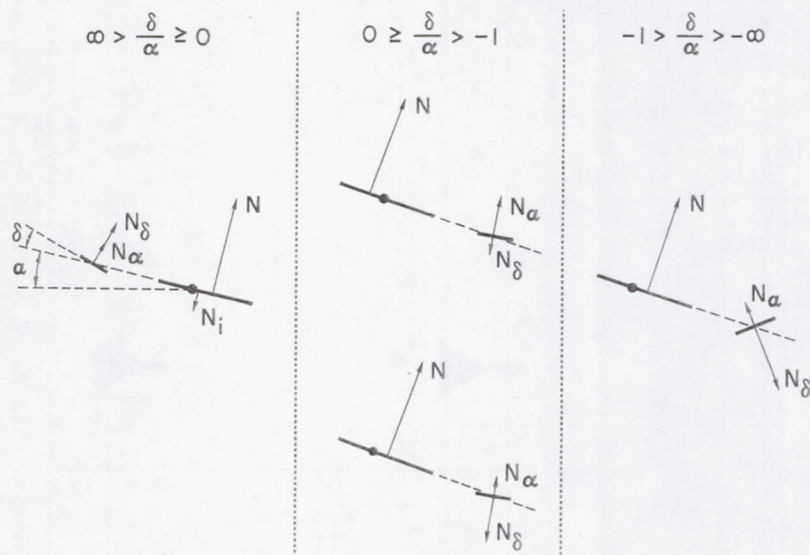

Figure 2

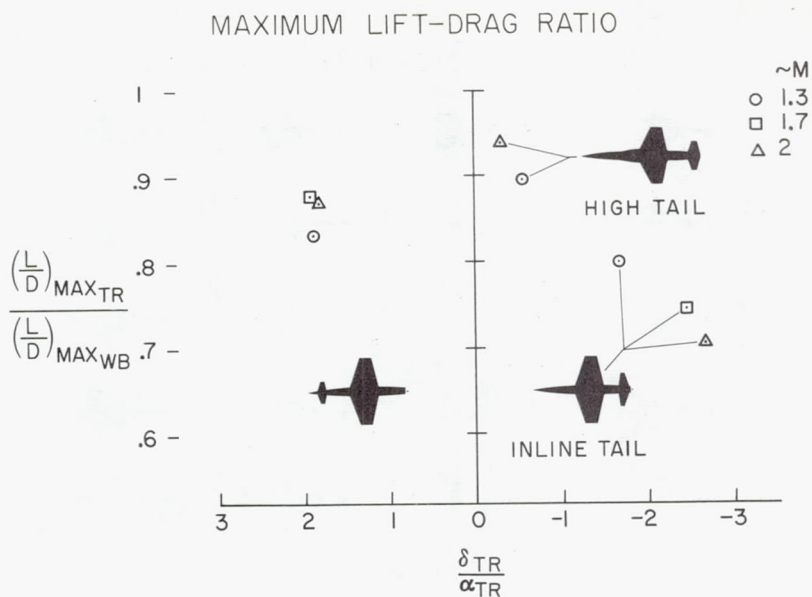

Figure 3

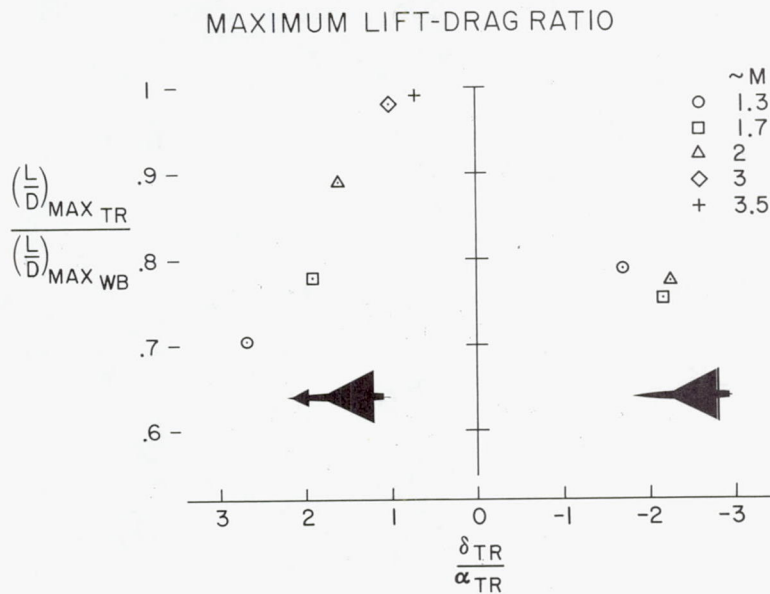

Figure 4

EFFECT OF MACH NO. ON CENTER OF PRESSURE

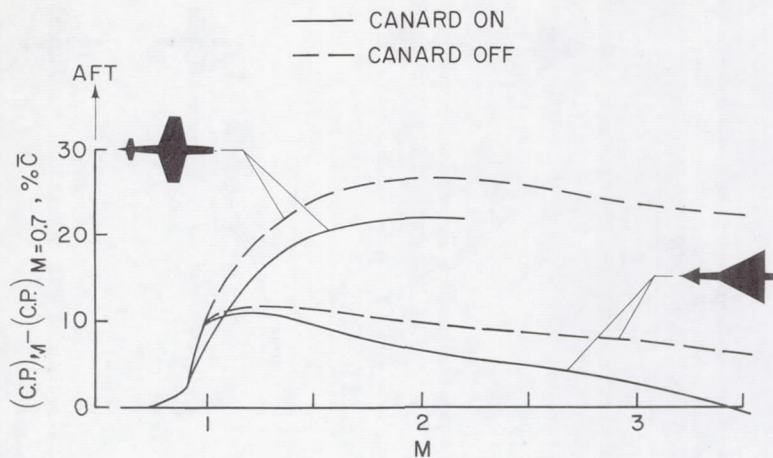

Figure 5

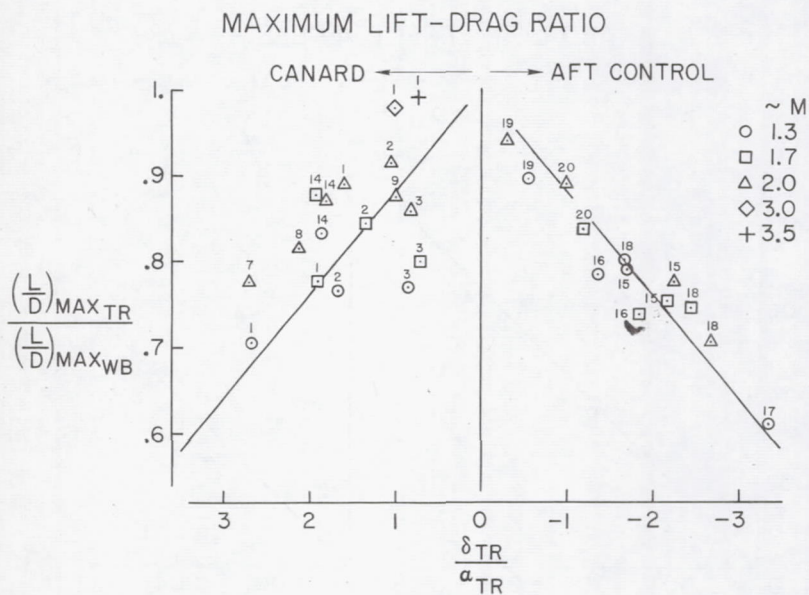

Figure 6

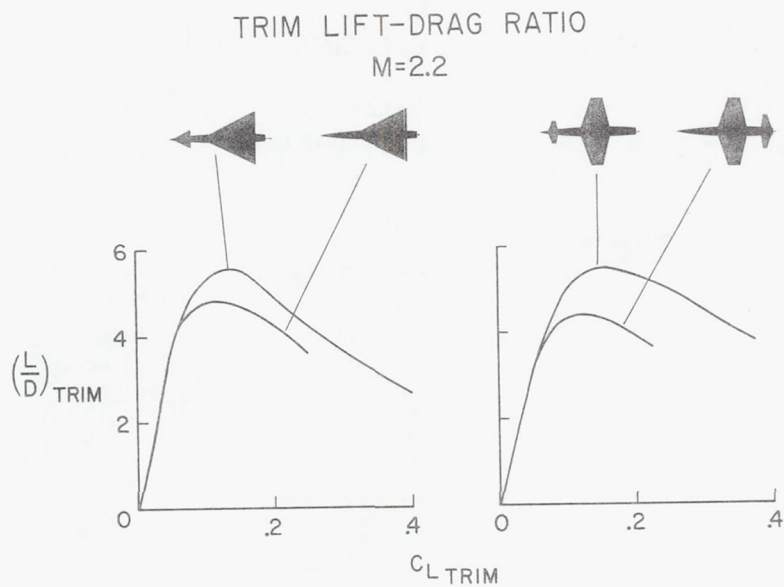

Figure 7

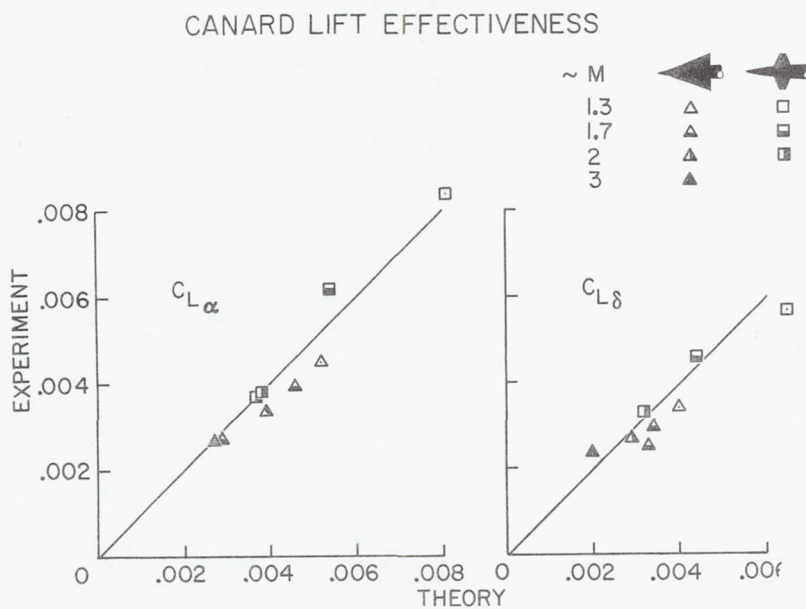

Figure 8

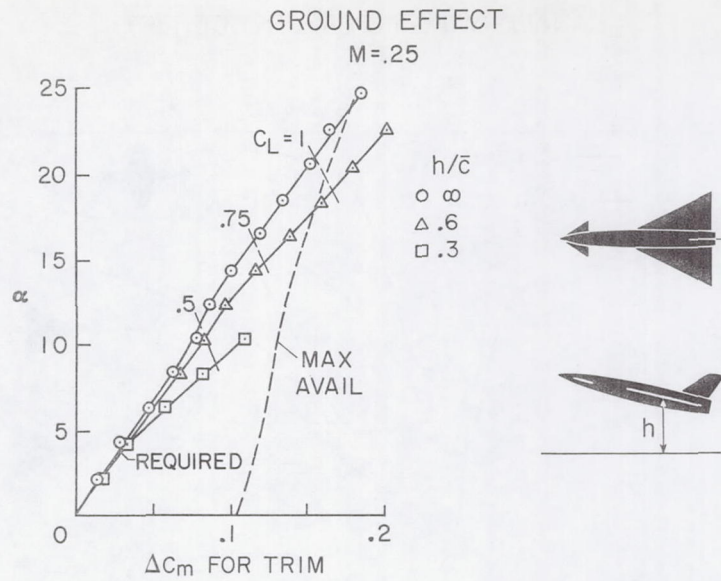

Figure 9

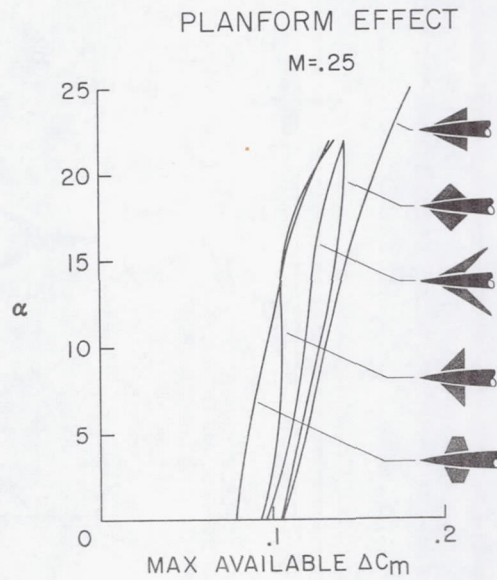

Figure 10

CANARD-WING INTERFERENCE LIFT

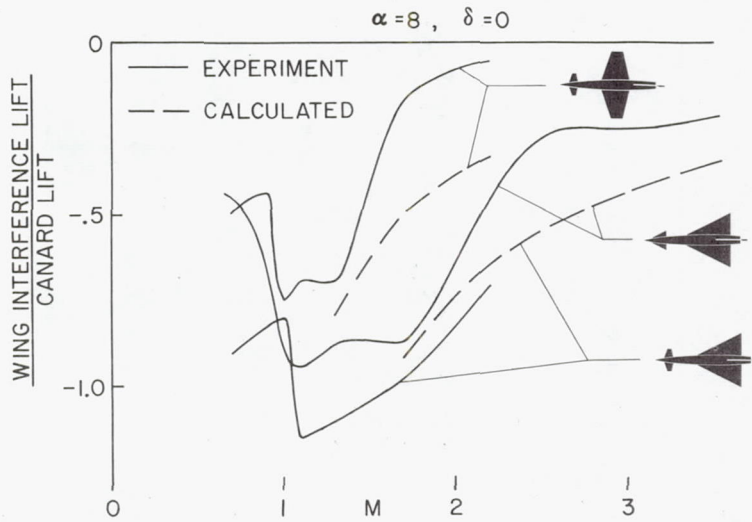

Figure 11

PITCHING-MOMENT INTERFERENCE

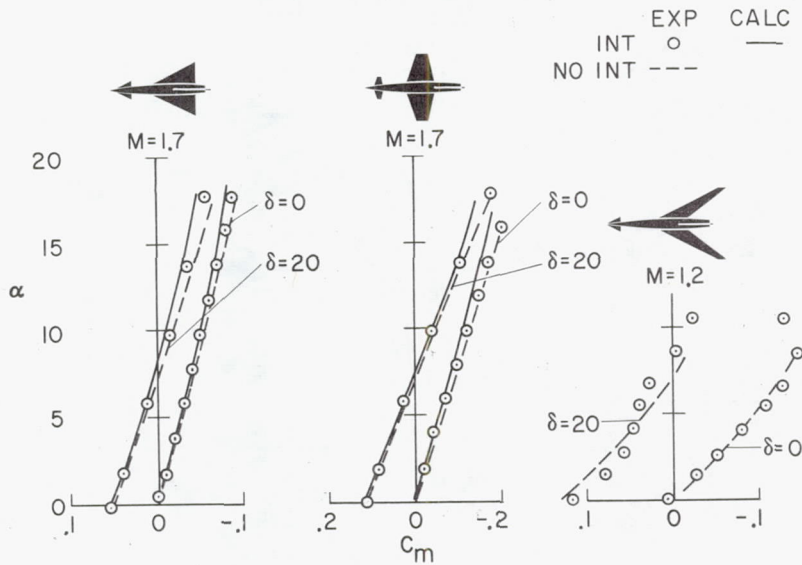

Figure 12

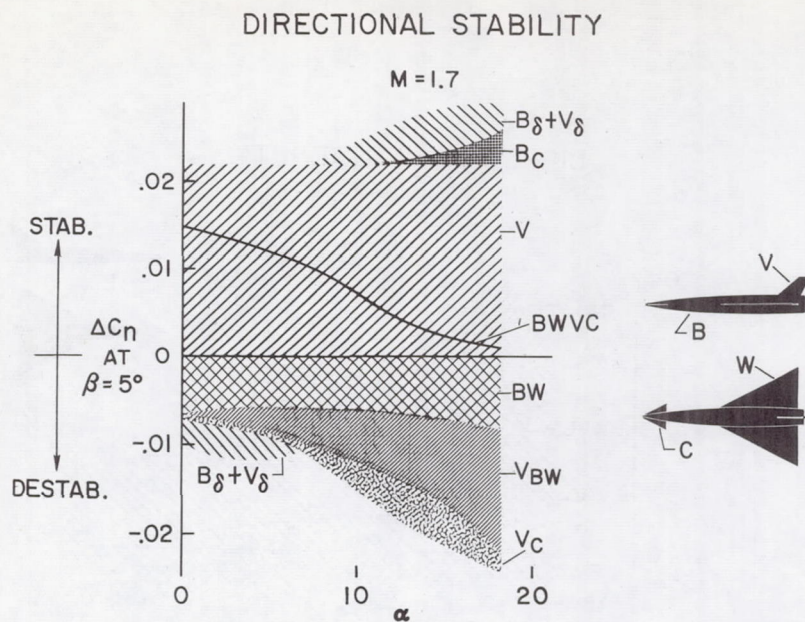

Figure 13

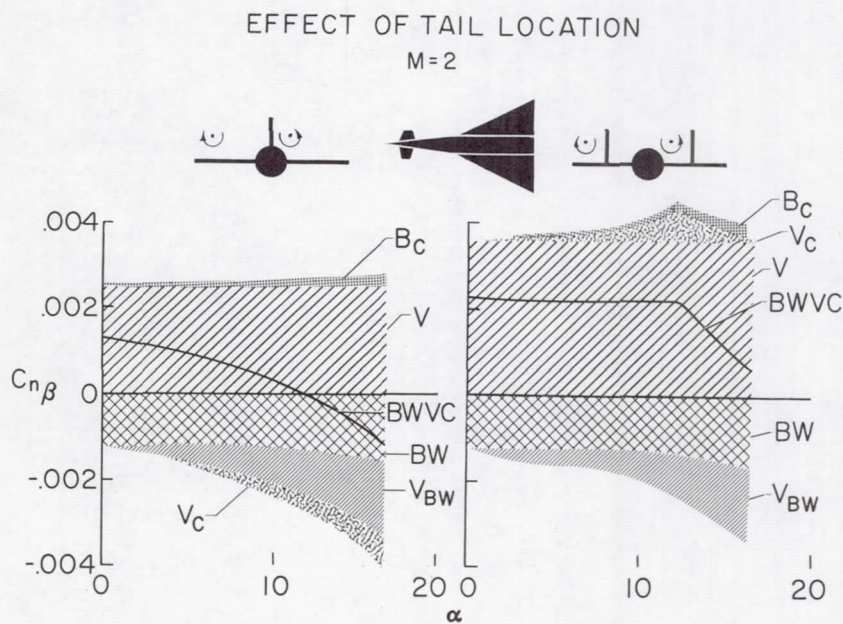

Figure 14

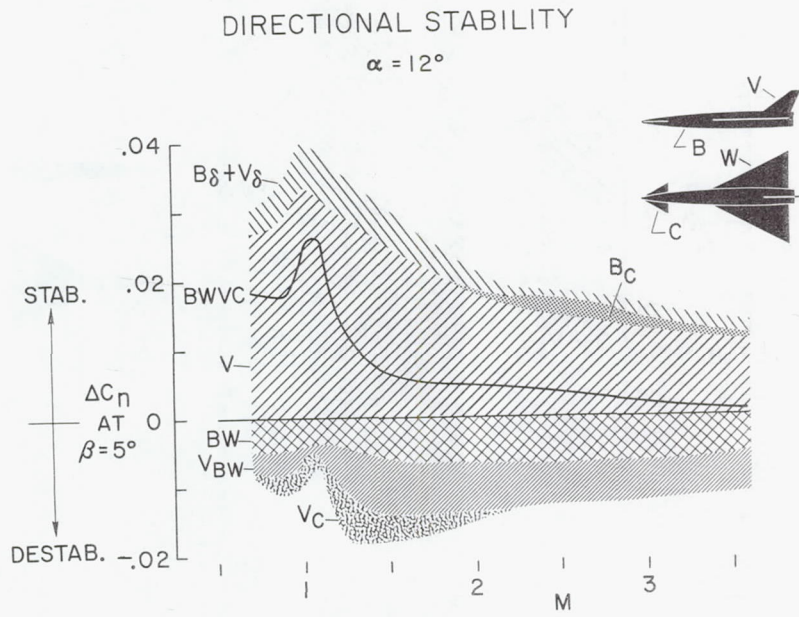

Figure 15