

~~CONFIDENTIAL~~

Copy 425
RM L58E26a



RESEARCH MEMORANDUM

Declassified by authority of NASA
Classification Change Notices No. ~~1000~~ 213
Dated ** JUN 30 1971

FLIGHT, ANALOG-SIMULATOR, AND ANALYTICAL STUDIES OF AN
AUTOMATICALLY CONTROLLED INTERCEPTOR WHICH USES A
BANK-ANGLE-ERROR COMPUTER FOR LATERAL COMMANDS

By Donald C. Cheatham and Roy F. Brissenden

Langley Aeronautical Laboratory
Langley Field, Va.

~~CONFIDENTIAL~~
~~CONFIDENTIAL~~
~~CONFIDENTIAL~~

~~CONFIDENTIAL~~
~~SPECIAL HANDLING~~
47

~~CLASSIFIED DOCUMENT~~

~~This material contains information affecting the national defense within the meaning of the espionage laws, Title 18, U.S.C., Secs. 793 and 794, the transmission or revelation of which in any manner to an unauthorized person is prohibited by law.~~

NATIONAL ADVISORY COMMITTEE FOR AERONAUTICS

WASHINGTON

August 11, 1958

~~CONFIDENTIAL~~



NATIONAL ADVISORY COMMITTEE FOR AERONAUTICS

RESEARCH MEMORANDUM

FLIGHT, ANALOG-SIMULATOR, AND ANALYTICAL STUDIES OF AN
AUTOMATICALLY CONTROLLED INTERCEPTOR WHICH USES A
BANK-ANGLE-ERROR COMPUTER FOR LATERAL COMMANDS*

By Donald C. Cheatham and Roy F. Brissenden

SUMMARY

Studies have been made of the tracking performance of an automatically controlled interceptor in which the deflection channel incorporated a bank-angle-error computer that commanded rolling velocities of the interceptor proportional to the computed bank-angle errors. Flight and analog-simulator studies showed that the modified system in the present investigation (including a bank-angle-error computer) offered no increased tracking performance over that of the prototype system which utilized a lateral command that produced a turning rate proportional to the deflection tracking error. In the presence of small tracking errors the lateral commands generated by the two systems were not significantly different. The modified system exhibited a long-period lateral tracking instability regardless of whether gravity considerations were included in the bank-angle-error computation. The modified system was stabilized, however, when the bank-angle-feedback term, which was used to approximate the gravity considerations, was made several times larger than that necessary to approximate gravity. This need for additional bank-angle feedback for lateral stability was largely attributed to bank-angle-response lags. Simplified analytical studies in which gravity terms were omitted from the bank-angle-error computation showed that for lateral tracking stability, the deflection-channel commands required were several times larger than those for the elevation channel. The lateral tracking stability was adversely affected by bank-angle-response lags but was relatively insensitive to elevation-response lags.

For an automatically controlled interceptor (as well as for a missile operating within the atmosphere) to utilize successfully a bank-angle-error computer that does not include gravity considerations in the computation, the deflection channel must have very small time constants in bank-angle response and be able to generate high maximum roll rates using large rolling-velocity commands. This high bank-angle response is not necessarily required for systems which provide a suitable means for stabilizing the lateral tracking loop.

*Title, Unclassified.

INTRODUCTION

As long as the range is an important factor in interceptor operations, interceptor configurations (and also many missile configurations which operate within the atmosphere) will probably continue to be monowing in order that the aerodynamic drag may be minimized. With such a configuration the interceptor must use the so-called bank-to-turn method of correcting for lateral tracking errors. When using this approach the tracking performance of an interceptor is to a large extent dependent upon its ability to change its bank angle quickly without exciting unstable oscillations in the tracking loop. (See refs. 1 and 2.)

Flight tests with a prototype automatically controlled interceptor system (ref. 3) have been made by the National Advisory Committee for Aeronautics at the Langley Laboratory. This system utilized a lateral command that in effect produced a turning rate proportional to the deflection tracking error by establishing a bank angle proportional to this tracking error. The lateral command was independent of elevation tracking errors.

In several analog-simulator studies (refs. 1, 2, and 4) pertaining to interceptor tracking performance, a somewhat different concept of interceptor lateral-command system that provided acceptable tracking performance was employed. The system resulting from this concept incorporates a bank-angle-error computer which uses both deflection and elevation tracking errors. The computer is of a type that commands the interceptor to bank so that the resultant-acceleration vector (lift plus gravity) together with the interceptor gun line forms a plane that contains the target. Such a control system appears to afford the most effective utilization of the force-producing capability of the interceptor in reducing the resultant tracking errors.

The results of analog-simulator studies indicated that an interceptor system using such a computer would be capable of stable lateral operation. These studies did not, however, establish the relative merits of this system compared with other types of systems such as the one originally installed in the test airplane (described in ref. 3). It was desirable then to see if significant improvements could be realized in the tracking performance of this interceptor by modifying the lateral-command system to include a bank-angle-error computer of the type described.

The purpose of this paper is to present the results of flight tests of the interceptor system with the lateral command modified to include such a bank-angle-error computer. In addition, results are presented of analog-simulator and analytical studies of this problem, which were made

to supplement the flight-test studies. Wherever possible, comparisons are made between the modified and the prototype interceptor system.

SYMBOLS

| | |
|---------------|---|
| b | wing span, ft |
| \bar{c} | mean aerodynamic chord, ft |
| $\bar{\mu}$ | elevation of radar-boresight axis with respect to interceptor armament-datum line, deg |
| μ | elevation of radar-boresight axis with respect to interceptor roll axis, deg |
| σ | tracking error (for zero lead-angle case, the angular displacement of interceptor radar-antenna axis from radar-boresight axis) |
| ω_{IS} | angular rate of line of sight, radians/sec |
| T_f | time of flight of projectile fired from interceptor to target, sec |
| a | acceleration, ft/sec ² |
| R | range from interceptor to target, ft |
| λ | kinematic lead angle, radians |
| K | constant |
| γ | flight-path angle, radians |
| θ | pitch angle, radians |
| ϕ | bank angle, radians |
| δ_e | elevator deflection, radians |
| δ_a | aileron deflection, radians |
| g | acceleration due to gravity, g units |
| V | velocity, ft/sec |



| | |
|----------------|---|
| (0) | initial condition |
| τ | time constant, sec |
| ϕ_e | bank-angle error (no gravity consideration), radians |
| $\bar{\phi}_e$ | computed bank-angle error (no gravity considerations included in computation), deg |
| $\phi_{e,g}$ | bank-angle error (including gravity), deg |
| K_E | elevation-channel gain, pitching angular velocity per degree of elevation tracking error, deg/sec/deg |
| K_D | deflection-channel gain, rolling velocity per degree of bank-angle error, deg/sec/deg |
| p | Laplace operator per second |

Subscripts:

| | |
|----|--|
| F | interceptor |
| B | target |
| E | elevation measurement in interceptor coordinates |
| D | deflection measurement in interceptor coordinates |
| XZ | vertical measurement in spacial coordinates |
| XY | horizontal measurement in spacial coordinates |
| IS | line of sight |
| c | commanded |
| A | response produced solely by elevator deflection (no gravity effects) |
| g | considering the effects of gravity |
| R | resultant |
| e | error |

n-1, n, n+1, . . . analytical sequence

A subscript associated with K denotes automatic-control-system gain on the signal symbolized by the subscript.





A dot above a quantity denotes differentiation with respect to time.

A prime above a quantity denotes that the quantity has been modified by feedbacks or a shaping network.

APPARATUS

Flight-Test System

The automatically controlled interceptor system consisted of a radar fire-control system, a tie-in computer, and an automatic pilot installed in a subsonic jet fighter airplane. A photograph of the airplane is presented in figure 1, and its dimensional and mass characteristics are presented in table I. Reference 5 covers the stability characteristics of this airplane. This interceptor system has been previously described in references 3 and 6 and will be described herein only in terms of the general operation of the system except for a description of the modifications that were made to include a bank-angle-error computer. In order to aid in understanding the significance of these modifications, appendix A, which discusses the considerations that were made prior to selecting a bank-angle-error computer, has been prepared.

Elevation Channel

The elevation channel is shown schematically by the block diagram in figure 2. The elevation tracking-error signal is combined with a pitch-rate feedback signal to effect a command of rate of pitch of the airplane proportional to the elevation tracking error. Pitch-acceleration feedback is utilized to improve control-loop stability. A pitch-trim synchronizer within the tie-in establishes a trim elevator deflection prior to engagement of the system, and this trim elevator signal is not changed during a run. No significant modifications were made to the elevation channel, and a detailed description of its operation and of the automatic-control gains that were used is contained in reference 6.

Deflection Channel

The deflection channel, before modifications were made to include a bank-angle-error computer, is shown schematically by the diagram in figure 3(a). A signal proportional to the deflection tracking error is combined with a feedback signal proportional to the interceptor



bank attitude to create an aileron-deflection command signal. In previous reports (refs. 3, 6, and 7) this has been described as a bank command system because it effects a bank attitude proportional to the deflection tracking error. However, this part of the system may also be envisioned as a simplified bank-angle-error computer because the signal produced is proportional to the difference between present and desired bank angle (bank-angle error). The computed signal is combined with a feedback of rolling velocity to give an aileron-deflection command that would produce a rolling velocity proportional to the bank-angle error. The bank angle that is reached in this system produces a turning rate of the interceptor that is approximately proportional to the deflection tracking error. Reference 6 gives a more detailed description of the operation of the deflection channel.

The deflection channel as it existed after the bank-angle-error computer was incorporated is shown schematically in figure 3(b). As is shown, the bank-angle-error computer is considered to be a part of the tie-in. It does, however, act as a separate element which utilizes the inputs of deflection and elevation tracking error, bank angle, and the constant K to compute the bank-angle error. The computed bank-angle-error signal is combined with feedback of rolling velocity to effect a command of rolling velocity of the interceptor that is proportional to the computed bank-angle error. Roll-acceleration feedback is utilized to improve control-loop stability.

The bank-angle-error computer was set up to solve (statically) the expression $\frac{\sigma_D - K_2\phi}{|\sigma_E| + K}$, which is discussed in appendix A. A schematic diagram of this computer is pictured in figure 4. At the summing point A, signals proportional to σ_D and to the gravity term $-K_2\phi$ are summed and then fed into one side of a balancing amplifier. The other side of this amplifier is fed from a variably excited potentiometer P. The pickoff from this potentiometer is positioned by a servomotor driven by the output of the balancing amplifier. Thus, the servomotor drives the pickoff arm until the signal returned to the balancing amplifier is equal to the input signal from point A. Because the potentiometer P is excited by a voltage proportional to the absolute value of the elevation position of the radar antenna and by a constant voltage proportional to K , the travel of the pickup arm driven by the servomotor is proportional to $\frac{\sigma_D - K_2\phi}{|\sigma_E| + K}$, where K is proportional to the minimum voltage picked off of resistors (1) and (2) when potentiometers P_1 and P_2 are at the center tap positions (the zero elevation position of the antenna).



Because the mechanization of the bank-angle-error computer included a servomotor, the computations did involve dynamic lag. In order to study the possible effect that this additional dynamic element might have upon the operation of the system, frequency-response tests were made of the computer. The tests showed that the computer amplitude response was nonlinear for high input levels probably because of rate-limiting of the servomotor. Flight-test results showed that this nonlinear type of operation was not encountered to any significant extent. The phase-angle lags associated with this servomotor in its linear range of operation, however, are of some significance. A typical plot of the amplitude and phase-angle variation of the computer response to an input of ϕ_e of 45° is presented in figure 5. These data show that the computer had a fairly constant output amplitude up to an input frequency of about 1 cycle/sec (6 radians/sec). The phase lag at this point was about 25° . Previous flight tests made with this interceptor, which were discussed in references 3 and 7, indicated a lateral mode of motion of the tracking loop of the interceptor at a frequency of about $1\frac{1}{4}$ radians/sec. The frequency of this mode is sufficiently low that its damping will not be greatly affected by the dynamics of the bank-angle-error computer. There were also (in ref. 7) indications of a mode of motion associated with the bank-attitude loop of the interceptor at about 1 to $1\frac{1}{2}$ cycles/sec (6 to 9 radians/sec), and it was expected that the phase lag of the bank-angle-error computer would decrease the damping of this mode somewhat. Because the bank-angle-error computer is outside the control loops (those associated with the roll rate and roll-acceleration feedback as shown in figure 3(b)), its dynamics would not affect the stability of those loops.

The aileron-servomotor response characteristics are the same as those described in reference 7. As will be discussed in a later section, the amplitude saturation of this servomotor at an aileron deflection of $\pm 5^\circ$ or less is considered an important factor in the system operation.

System Gains

One of the purposes of this paper is to compare the performance of the modified system with the prototype system. A factor in the comparison would be the gains utilized in the automatic control system. The elevation channel was not modified, and its gains are the same for both systems. The gains associated with roll rate and roll acceleration are the same for both systems. Although the basic quantity upon which the forward-loop gain operates is theoretically different for the two deflection systems studied, the approximation of the bank-angle-error computation used in this investigation does afford a comparison



of the corresponding gains associated with the deflection tracking error and the bank-angle feedback for the two systems. This correspondence may be seen by considering that the gain K_{ϕ_e} is applied to the output

of the computer so that the magnitude of the roll-rate command signal is proportional to $K_{\phi_e} \frac{\sigma_D - K_2 \phi}{|\sigma_E| + K}$. By rearranging this expression to have the form

$$\frac{K}{|\sigma_E| + K} (K_{\sigma_D} \sigma_D - K_{\phi} \phi)$$

where

$$K_{\phi_e} = K K_{\sigma_D}$$

and

$$K_{\phi_e} K_2 = K K_{\phi}$$

it can be seen that signals proportional to the deflection tracking error and the bank attitude are combined and are modified by the function $\frac{K}{|\sigma_E| + K}$. The deflection-tracking gain K_{σ_D} and the bank-angle-feedback gain K_{ϕ} may be compared directly with corresponding gains of the original system for small elevation errors; and it is apparent that the differences that may exist in the operation of the two systems can be attributed either to differences in these two gains, to the modification afforded by $\frac{K}{|\sigma_E| + K}$, or to the frequency-response characteristics of the bank-angle-error computer, or to any combination of the three. A variation of the function $\frac{K}{|\sigma_E| + K}$ with $|\sigma_E|$ for several values of K is presented in figure 6.

In all the flights the value of K was a preset constant, and in the majority of the tests reported herein the setting of K was equivalent to about $2/3^\circ$. The pilot did have control over the gains K_{σ_D} and K_{ϕ} and could change them as he desired. The gains K_{σ_D} and K_{ϕ} that were considered normal during the flight and analog-simulator tests



are presented in table II along with other control-system gains that (except in special cases) were held constant at values which were common to both the modified and the original system. At normal values of K_{σ_D} and K as stated in table II, the gain on the output of the modified system in terms of roll-rate command for each degree of bank-angle error $\dot{\phi}/\phi_e$ was about 0.70° per second of roll rate per degree of bank-angle error.

TESTS

Flight Tests

Flight tests were made with the deflection channel modified to include a bank-angle-error computer. Flight tests were also made with the deflection channel in its original form in order to provide additional data for comparative purposes. The tests were conducted at an altitude of 20,000 feet at a speed corresponding to an indicated Mach number of 0.76. Attempts were made to establish a range of about 1,000 yards with zero closing rate prior to the start of each run. The test runs that were used were based upon a simple maneuver by either the interceptor or the target in the interest of being able to repeat runs. The runs all began in a straight and level tail chase and were of the following two general types:

(1) Runs in which the automatic interceptor system was engaged with an initial tracking error in deflection. The runs included the transient response during the time that the interceptor system attempted to establish steady tracking on a nonmaneuvering target.

(2) Runs in which the target executed a fairly rapid transition from straight and level flight to a steady turn.

In the course of the flight tests various gain levels were utilized in the deflection channel. Most of the test runs presented herein, however, were made with the gains listed in table II. Wherever gains different from the basic set were used, the particular gain value will be specified.

Runs were made both with and without lead-angle computation. In addition, variations were made in the elevation of the radar-boresight axis with respect to the armament-datum line over a range from $1/2^\circ$ to 5° in the same manner as that described in reference 7.



Analog Simulation

The analog-simulator studies were based on the representation of the interceptor problem presented in figure 7. This simulation of the modified system is the same as that used in the studies reported on in reference 7. Briefly, this simulation utilized a linear representation of the airplane and simplified the representation of other system components. These representations were based upon experimental (flight and bench tests) data. No cross-coupling terms are included in the representation of airplane pitch and roll response, and it was assumed that the interceptor was stabilized so that no sideslip angles were produced. Limits were imposed on the outputs of the various components to correspond roughly to limits that were encountered during the flight tests. The radar dynamics were assumed to be perfect; that is, the radar exactly established the line of sight to the target at all times. Provisions were also made to vary the elevation of the radar-boresight axis in the same manner as that described in reference 7.

In addition, the simulation was altered in order that it would be analogous to the interceptor system as it existed before being modified to include the bank-angle-error computer in order to provide data for comparative purposes.

Tests on the analog simulator utilized the same type of runs as the flight tests. Again, both "with lead angle" and "without lead angle" runs were made. Variations in the elevation of the radar-boresight axis were made in the range from -2° to 10° referenced to the interceptor roll axis.

Analytical Studies

Analytical studies were made of the tracking performance of an automatic interceptor using a bank-angle computer in an attempt to gain some insight on the fundamental relationship between the stability of the lateral tracking loop and the rolling and elevation response. These studies involved a much simplified approach in which a point-by-point calculation was made of the path (starting from a specified orientation with respect to the target) which was described by the intersection of the projected flight path of the interceptor upon a plane perpendicular to the line of sight from the interceptor to the target and including the target. (See fig. 8.)

The elevation channel of the assumed analytical system controlled normal acceleration. The deflection channel utilized a perfect bank-angle-error computer (no dynamics) and the lateral-control system was specified as one that produced a rolling velocity proportional to the



bank-angle error, the proportionality determined by the gain K_D . The bank-angle-error computer that was assumed was studied both with and without gravity considerations in the computations. The elevation-channel control system produced a normal acceleration proportional to the elevation tracking error as determined by the gain K_E . In addition, a constant $1g$ trim lift force was added. This trim lift force produced added increments of $\dot{\gamma}$ at bank angles other than that in level flight. Although the elevation channel of the analytical system utilized a normal-acceleration control, it is believed that factors affecting the response of this system would apply at least qualitatively to systems having a pitch-rate control such as the flight and analog systems described in the present paper. Equations utilized in the analytical studies are presented in appendix B.

RESULTS AND DISCUSSION OF FLIGHT AND ANALOG TESTS

General Comments

During the course of the investigation the flight tests and the analog-simulator tests were made concurrently rather than as separate phases of an overall investigation. There was generally good agreement between the results of the two types of testing. The results of the tests are discussed in more or less the chronology in which the tests were conducted; that is, first, the tests in which the gravity terms were neglected in the bank-angle-error computation are discussed, and, second, the tests in which these terms were included.

Wherever applicable, results are also presented for the system in its prototype form (before incorporating a bank-angle-error computer) to enable comparisons to be made. Some of the basic differences between the modified and the prototype system and the importance of these differences are discussed.

All the results that are discussed are from tests in which the lead-angle computer was not operating. Experience in comparing operation with a lead-angle computer with operation without a lead-angle computer gives rise to the belief that these results have equal application to the case with lead angle. It is to be expected, however, that cases with lead angles included would exhibit some decrease in system stability.



Gravity Terms Omitted in Bank-Angle-Error Computation

Flight tests.- During the initial flight tests the bank-angle-error computation $\frac{K}{|\sigma_E| + K} (K_{\sigma_D} \sigma_D - K_{\phi} \phi)$ did not include the gravity term $K_{\phi} \phi$ and the values of K that were used were chosen arbitrarily.

Flight-test results showed that the long-period (4 to 5 seconds) mode of lateral motion was a diverging oscillation for all values of K and K_{σ_D} when the gravity term was omitted. A typical example is shown in figure 9.

Analog-simulator studies.- Studies were also made on the analog simulator in which the bank-angle-error computation did not include gravity terms. The results were much the same as those for the flight tests in that a long-period lateral oscillation developed regardless of the gain on the output of the bank-angle-error computer. Figure 10 presents a typical time history of deflection tracking error, aileron deflection, and bank angle for a case where the system was engaged with an initial deflection tracking error.

The fact that stable operation was obtained in previous interceptor studies (refs. 1, 2, and 4) using a bank-angle-error computer in which gravity considerations were not included is believed due to the faster bank-angle response of the systems previously considered as compared with the present system. The bank-angle response of the present system was limited chiefly by servo dynamics and amplitude limiting.

Gravity Terms Included in Bank-Angle-Error Computation

Flight tests.- Gravity terms were included in the bank-angle-error computation by adjusting the operation of the computer in accordance with equation (4) and by using appropriate settings of K_2 and K . The flight tests that were made with this type of computer operation did not indicate that any appreciable damping was added to the long-period lateral motion of the interceptor compared with the tests made without gravity considerations in the computation. However, by taking advantage of the flexibility of the bank-angle-error computer and by increasing the gain on the individual term $K_{\phi} \phi$, which is a function of K_2 and K_{ϕ} and is associated with the gravity consideration; it was possible to stabilize the long-period motion. A time history of a typical run is shown in figure 11. Because of a shaping network $\frac{1 + 2p}{1 + 4p}$ in



the tie-in (see ref. 6), the actual gain on the signal proportional to the interceptor bank angle was a function of the frequency of the rolling motion. At low frequencies (less than about $1/4$ radian/sec) the $K_2\phi$ term was about $4\frac{1}{2}$ times as great as would be required for a close approximation of the gravity term, and at higher frequencies (greater than $1/2$ radian/sec) the $K_2\phi$ term was about $2\frac{1}{4}$ times as great as the gravity approximation. It is believed that the need for such a large stabilizing signal is a result of the lags that exist in the deflection channel of the interceptor system.

The increased gain on the terms associated with the gravity consideration (bank-angle signal) results in the system being somewhat slower to respond to a given tracking-error condition and increases the steady-state errors that result when tracking a target-turning maneuver. Some of the solutions to such problems are discussed in reference 3.

As was pointed out in reference 7, elevating the radar-boresight axis of the interceptor provided a stabilizing geometric feedback that, to an extent depending upon the amount that the radar-boresight axis was elevated, could be used to replace the electrical bank-attitude-feedback signal $K_2\phi$. Figure 12 shows time histories of a run made with the interceptor system utilizing the bank-angle-error computer (without consideration of gravity) and also with the unmodified (prototype) system in which the radar-boresight axis was elevated $3\frac{1}{2}$ above the armament-datum line. The gain on the bank-attitude-feedback term was set at zero for both configurations, and the resulting runs showed about the same stability and tracking performance. Thus, the radar-boresight axis is equally effective in eliminating the need for the electrical bank-attitude-feedback signals for the two systems. With the electrical bank-angle feedback eliminated, the systems were able to track the target during the turn maneuver with only small errors being created. It is apparent that with this type of roll stabilization very high roll response is not necessarily a requirement for good tracking performance.

Analog-simulator studies.- The results of the analog-simulator studies in which gravity considerations were included in the bank-angle-error computation closely paralleled those of the flight tests. In essence, they showed that the interceptor system was not stabilized by the inclusion of gravity in the bank-angle-error computation. For stability, the term associated with gravity (approximated by a bank-angle feedback) had to be increased by about the same proportion as that in the flight tests. This increase in the bank-angle-feedback term increased the steady-state error when tracking target maneuvers;





however, this problem could be alleviated (as in the analog of the prototype system) by elevating the radar boresight and eliminating the need for electrical bank-angle feedback.

Comparison of Modified System Using Bank-Angle-Error

Computer With the Prototype System

Flight tests.- When a change was made in the interceptor control system for either the prototype or the modified system (such as a change in the constant K or a change in the elevation of the radar-boresight axis), the flight tests included a period in which the pilot made gain adjustments in the deflection channel in an attempt to obtain the optimum tracking performance. The gain adjustments were primarily concerned with the gains K_{σ_D} and K_{ϕ} . In determining optimum settings, more importance was attached to obtaining desirable stability and tracking-response characteristics in the region of small errors than at other tracking conditions. This was felt to be a logical procedure because the interceptor must certainly have adequate stability and tracking-response characteristics in the small-error region in order to obtain hits on a target airplane.

The gains that were determined during this adjustment period were found to be almost the same for the modified interceptor system as for the prototype interceptor system and the resulting tracking performance was for all practical purposes the same. An example of this similarity is shown in figure 13 which presents time histories of runs originating with an initial deflection tracking error of about 65 mils. The gains used in both runs were about the same as those specified in table II. The time histories show a close resemblance between the tracking performance of the two systems. The apparent difference in frequency as the steady-state portions of the runs are approached could be due to a combination of several factors such as small differences in effective gains, shifts in the radar-boresight axis, different radar-noise conditions, and so forth. Generally, though, no significant differences were found between the tracking performances of the modified interceptor system and the prototype system.

Analog-simulator studies.- In the flight tests the similarity of tracking performance that was noted between the interceptor system with a bank-angle-error computer and the prototype system was also noted in the analog simulation. In an effort to determine if one system was able to utilize higher gains in the deflection channel than the other system, and thereby achieve better tracking performance, runs were made in which the gains K_{σ_D} and K_{ϕ} were adjusted for optimum deflection-channel



response. This was done for three different elevations of the radar-boresight axis with respect to the roll axis (-2° , 0° , and 2°). In general, it was found that as in the flight tests the gains set up were practically the same for both systems and that no significant differences were noted in their tracking performance.

General considerations.- In the preceding paragraphs the similarity of tracking performance between the modified and original interceptor systems has been noted in both flight tests and analog-simulator studies. In order to understand why this similarity exists it is desirable to compare the deflection-channel commands generated in these two systems during various tracking-error situations. In order to avoid any uncertainties regarding the validity of the approximate computation of bank-angle error used in the present tests, consider the comparison of the

expression of command $K_{\phi_\epsilon} \tan^{-1} \frac{\sigma_D - K_1 \sin \phi}{\sigma_E + K_1 \cos \phi}$ and the corresponding command generated in the original deflection channel expressed by $K_{\sigma_D} \sigma_D - K_{\phi_\epsilon} \phi$ for the following three tracking-error situations:

(1) Small tracking errors in level flight: If the interceptor is in level flight and tracking the target with small errors, the command that would be generated in the bank-angle-error system by a sudden deflection error would be approximately $K_{\phi_\epsilon} \tan^{-1} \frac{\Delta \sigma_D}{K_1 \cos \phi}$. If small-angle

approximation is used, this expression simplifies to $\frac{K_{\phi_\epsilon}}{K_1} \Delta \sigma_D$. For the original deflection channel the command would be $K_{\sigma_D} \Delta \sigma_D$. It can be seen that in both cases the command is a linear function of the deflection error. The commands for the two systems would be the same if the gain $\frac{K_{\sigma_D}}{K_1}$ were equal to K_{ϕ_ϵ} .

If the same conditions exist except for a sudden change in bank attitude instead of a change in deflection error, the modified deflection-channel command could be expressed as $K_{\phi_\epsilon} \tan^{-1} \frac{-K_1 \sin \Delta \phi}{K_1 \cos \Delta \phi}$ which can be simplified to $K_{\phi_\epsilon} (-\Delta \phi)$. The original deflection-channel command would simply be $-K_{\phi_\epsilon} \Delta \phi$ and, again, both are linear functions of the variable bank angle and would be the same if K_{ϕ_ϵ} (the modified system) were equal to K_{ϕ_ϵ} (the prototype system).

(2) Small-deflection tracking errors and large-elevation tracking errors in level flight: If the effect of elevation response is neglected, a sudden deflection error would produce a command in the bank-angle-error system that would be expressed by $K_{\phi_e} \frac{\Delta\sigma_D}{\sigma_E + K_1}$ (again by using small-angle approximation) as compared with $K_{\sigma_D} \Delta\sigma_D$ for the prototype system. The command in the bank-angle-error system is decreased as elevation error is increased and, thus, under these conditions would respond more slowly to a given deflection error than would the original deflection system (if it is assumed that they respond equally at small elevation errors).

With these same conditions of very small deflection errors and large elevation errors, consider the effect of a small change in bank angle (again by neglecting elevation response). This condition was discussed in detail in reference 7 and it was pointed out that the resolution of elevation tracking error into deflection tracking error produced a term which was essentially the same as a bank-angle feedback. For the bank-angle-error system, the command generated would be

$$K_{\phi_e} \frac{-\sigma_E \Delta\phi - K_1 \Delta\phi}{\sigma_E + K_1}$$

or

$$-K_{\phi_e} \frac{(\sigma_E + K_1) \Delta\phi}{\sigma_E + K_1}$$

as compared with

$$K_{\sigma_D} (-\sigma_E \Delta\phi) - K_{\phi} \Delta\phi$$

or

$$-(K_{\sigma_D} \sigma_E + K_{\phi}) \Delta\phi$$

for the original system. Again, the bank-angle-error command is decreased as a function of the elevation error. Under these conditions where an additional effective bank-angle feedback is present that would tend to give increased bank-angle stabilization, there does not appear to be any advantage in reducing the deflection-channel-command gain in the same way that the bank-angle-error computer does when an increase occurs in elevation tracking error. In fact, such a variation seems

contrary to the intended purpose of the bank-angle-error computer of providing for rapid interceptor bank-angle response so that the lift-producing capabilities can be more directly utilized in reducing the resultant tracking errors. This difference in operation of the two systems does not manifest itself in a difference of tracking performance because with the good elevation response (described in ref. 3) of the test system only a short time is needed to reduce a considerable elevation tracking error. However, this difference in command might become more important in systems in which much more rapid reductions of tracking errors are desired than were considered satisfactory with the present interceptor.

(3) Large tracking errors: At very large deflection errors, both types of deflection channels would produce large commands that would effect maximum aileron deflection and, thus, would initially result in identical interceptor response; however, if the two deflection systems produce the same level of command in the small-error region, then the prototype system will always produce the higher command when the errors are large. For example, figure 14 presents a comparison of commands generated in the prototype system with those produced by a bank-angle-error computer as the radial tracking error is increased (by using gains specified in table II). If the aileron is limited to about $\pm 4\frac{1}{2}^\circ$ as it was in the test system, it can be seen that radial errors greater than about 1.0° could cause limiting in both systems. In the intermediate-error range around a radial error of 0.5° the commands are different. In this region the effective reduction in forward-loop gain for the system with the bank-angle computer would result in the ailerons becoming unlimited earlier, which would aid in stabilizing any tendency toward a limiting oscillation. This characteristic did not appear to be a factor in the system investigated. Generally, it appears that nothing was gained by modifying the deflection channel of the interceptor to include a bank-angle-error computer. In fact, the added complication of the computer would certainly be a factor against use of that system.

RESULTS AND DISCUSSION OF ANALYTICAL STUDIES

Gravity Terms Omitted in Bank-Angle-Error Computation

In the analytical studies (in which the elevation channel controlled normal acceleration rather than pitch rate), some of the basic system parameters were varied in order to understand better their relationship with system response. The analysis initially assumed a bank-angle-error computation in which the gravity terms were not included; that is,

$$\phi_e = \tan^{-1} \frac{\sigma_D}{\sigma_E}$$

Figure 15 shows the effect of varying the deflection-channel gain K_D and of holding the elevation-channel gain K_E constant for the case where the assumed system responds with no lags. The value of K_E was 0.87g per degree of elevation tracking error; and the values of K_D were 2° , 4° , and 10° per second of roll rate per degree of bank-angle error. The bank attitude of the interceptor is indicated at each 0.2-second time interval. For the runs shown there is a definite increase in the stability of the lateral tracking loop as the gain K_D is increased. With the highest value of K_D used (10 deg/sec/deg), the response shows only a slight overshoot in deflection error. The use of such a high gain in the deflection channel may not be feasible in actual systems because of inner loop instabilities; and this was the case in the interceptor system used in the flight tests reported herein. If other than an infinite range had been assumed in the analysis, it would be expected that the stability of each run would be somewhat decreased.

The tracking error and bank angle presented in figure 16 show the result of adding a simple first-order lag with a time constant of 0.4 second to the interceptor bank-angle response. Also shown is the result of adding this same lag to the bank-angle response and, in addition, of adding a similar lag with a 0.2-second time constant to the normal-acceleration response. These time constants are considered fairly representative of the airframe response of an interceptor such as the prototype system used in the flight tests. With either of these combinations of lags, the response of the system with a gain K_D of 4 deg/sec/deg of bank-angle error shows a long-period lateral oscillation with close to zero damping. Increasing the normal-acceleration lag to 0.8 second indicates that the stability of the lateral tracking loop is relatively insensitive to the lag in the elevation response. An additional run not shown in figure 16 indicated that increases in the deflection-channel gain K_D did not cause an increase in the lateral stability of the system when the system had a 0.4-second time constant in roll. Thus, it is apparent that, for an interceptor system of this type to be able to utilize a bank-angle-error computer that does not include gravity terms in the computation, the system response must have a low time constant in roll, be able to use high roll-rate gains, and have high maximum roll rates. It should not be construed from these studies that these response characteristics are necessarily required for other types of systems which provide for lateral-tracking-loop stability.

Another relationship that was brought out by the analysis is presented in figure 17 which shows that increasing the gain on the elevation channel while holding the deflection-channel gain constant has the effect of decreasing the stability of the system. Thus, it is apparent that the gain on the elevation channel affects the stability of the lateral

tracking loop. Under the assumed conditions of the analytical studies where the interceptor airspeed was 800 ft/sec, the normal-acceleration gains used in the runs shown in figure 17 are equivalent to gains on the rate of change of flight path $\dot{\gamma}$ of 0.87g, 1.74g, and 2.61g per degree of elevation tracking error. Comparing these gains with the roll-rate gain used (4 deg/sec/deg of ϕ_e) indicates that for good lateral stability the roll-rate gain should be several times greater in magnitude than the elevation-channel gain expressed in terms of the angular rate of change of flight path (deg/sec/deg of ϕ_e). It seems very probable that this relationship would roughly apply to interceptor systems, such as the one used in the flight tests, in which the elevation channel commands a pitching angular velocity.

As may be noted in figures 15, 16, and 17, the cases in which the calculated response was stable were discontinued when the tracking errors approached zero. This was done because in each of these cases when the errors approached zero there resulted a rather high frequency lateral oscillation of neutral stability, and the limitations of the calculating procedures prevented an accurate determination of this motion. This trend toward instability is indicative of the need for modifying the deflection-channel command when the tracking errors approached zero and is discussed in appendix A.

Gravity Terms Included in Bank-Angle-Error Computation

For the simplified analytical studies the bank-angle-error computation was described by the exact function including a gravity consideration. (See eq. (1).) The results presented in figure 18 show that with no system lags the interceptor banks until its path is headed almost directly at the target. The gains used in this run were $K_E = 0.87g$ per degree of elevation error and $K_D = 4$ deg/sec/deg of ϕ_e . There is a slight overshoot laterally, but the path settles down right on target. If a higher gain K_D had been employed in the deflection channel, the path to the target would probably have been more direct. By adding a first-order lag with a time constant of 0.4 second, the bank-angle response causes the calculated path to go initially above that for the no-lag case. As shown in figure 18, when the path reaches the vicinity of the target there is an appreciable overshoot and the lateral motion that follows is practically a neutrally stable oscillation. It is apparent then that, with appreciable lags in the bank-angle response, additional stabilization is required over that supplied by including gravity terms in the computation. Comparing the case with the lag in the bank-angle response with the corresponding case without gravity considerations in the bank-angle-error computation (see fig. 16) shows that the gravity terms did effect an improvement in the interceptor

response. However, in order to provide for satisfactory lateral-tracking-loop stability, the roll-stabilization-feedback term that would be required might be large with respect to the gravity terms, as was the case in the flight and analog tests.

CONCLUSIONS

Flight-test and analog-simulator studies were made of the tracking performance of an automatically controlled interceptor whose elevator channel controlled pitch rate. In addition, analytical studies were made of the tracking performance of an automatically controlled interceptor whose elevator channel controlled normal acceleration. As a result of these studies, the following conclusions have been drawn regarding the use of a bank-angle-error computer to generate interceptor roll-rate commands:

1. The flight interceptor system was unstable laterally (4- to 5-second-period oscillation) regardless of whether or not gravity terms were included in the bank-angle-error computation.
2. In order to stabilize the long-period lateral mode of the interceptor, it was necessary to increase the gain on the bank-angle-feedback signal (associated with the consideration of gravity effects) to a point where this term was several times as great as that required to approximate the gravity term.
3. The need for additional lateral-tracking-loop stability (beyond that supplied by gravity considerations in the bank-angle-error computer) is attributed primarily to the lags in the bank-angle response of the interceptor.
4. Positive elevation of the radar-boresight axis of $3\frac{1}{2}^{\circ}$ provided a geometric feedback which eliminated the need for the bank-angle-feedback term in the bank-angle-error computation.
5. No advantage in increased tracking performance was obtained by modifying the prototype interceptor system from one which commanded a bank angle proportional to deflection tracking error to one which utilized a bank-angle-error computer to command interceptor rolling velocity.
6. In the presence of small tracking errors the lateral commands generated by the modified deflection system, which included a bank-angle-error computer, were not significantly different from commands generated by the prototype system.

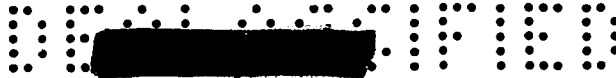

7. Simplified analytical studies of an interceptor system utilizing a bank-angle-error computer in which gravity terms were omitted indicated the following results:

(a) Increased elevation-system gain decreased the lateral stability.

(b) In order to maintain good lateral stability, the roll-rate gain should be several times as high as the angular-rate gain effected in the elevation channel.

(c) The stability of the lateral tracking loop was relatively insensitive to lags in elevation response, but was very sensitive to lags in the lateral response.

(d) In the absence of lags in the bank-angle response of the interceptor, the stability of the lateral tracking loop increased with an increase in roll-rate gain.

8. Provided that a suitable means of stabilizing the lateral tracking loop is used (such as that resulting from elevating the radar-boresight axis), very high bank-angle response is not necessarily required for good tracking performance.

Langley Aeronautical Laboratory,
National Advisory Committee for Aeronautics,
Langley Field, Va., May 16, 1958.



APPENDIX A

PRELIMINARY CONSIDERATIONS IN THE SELECTION OF A

BANK-ANGLE-ERROR COMPUTER

Background of Problem

Many of the factors involved in the selection of a bank-angle-error computer are discussed in reference 8. In this reference a bank-angle-error expression is derived for a rocket-firing system which controls normal acceleration and bank attitude. This bank-angle-error expression is applicable in the present tests except for terms associated with gravity considerations. The present flight-test system controls the angular position of the interceptor body axis through control of the pitch rate (suitable for a gun-laying system). It is desirable, however, to discuss briefly the derivation of the bank-angle-error equation of reference 8 because the fundamental approach involved leads to a better understanding of the factors which should be considered.

A diagram of the tracking problem is presented in figure 19(a) which shows the projection of the interceptor radar coordinate system upon a plane perpendicular to the interceptor gun line or radar-boresight axis and containing the target. A rear-view silhouette of the interceptor is included to indicate its banked attitude. For a system which controls normal acceleration it is desired that the interceptor be banked to such an attitude that the resultant acceleration (made up of normal acceleration and gravity) combines with the interceptor gun line to form a plane that includes the target. The equation for the computation of the difference between present and desired bank angle may be written as

$$\phi_{\epsilon, g} = \tan^{-1} \frac{a_D - g \sin \phi}{a_E + g \cos \phi} \quad (1)$$

where the terms a_D and a_E are the deflection and elevation components (aligned with the instantaneous position of the interceptor coordinate system) of the desired resultant acceleration. By using the similar triangles existing in figure 19(a), it can be seen that

$$\frac{a_E}{\sigma_E} = \frac{a_D}{\sigma_D} = \frac{a_R}{\sigma_R} = \frac{g}{K_1}$$

Equation (1) may be expressed in a somewhat different form (for convenience in the present studies) by applying these similar triangle relations. The equation, thus, becomes

$$\phi_{\epsilon, g} = \tan^{-1} \frac{\sigma_D - K_1 \sin \phi}{\sigma_E + K_1 \cos \phi} \quad (2)$$

If the gravity terms are comparatively small, it is possible that equation (2) can be simplified to

$$\phi_{\epsilon} = \tan^{-1} \frac{\sigma_D}{\sigma_E} \quad (3)$$

and still provide a satisfactory computation of bank-angle error. In such a case as that shown in figure 19(b), the desired bank angle becomes simply that which would cause the plane of symmetry to include the target. This simplified equation (eq. (3)) was used to compute the bank-angle errors in the studies presented in references 1, 2, and 4; and in each of these studies the interceptor system was able to track within fairly acceptable limits. Some of the time histories presented in these references did, however, show the existence of a lateral tracking oscillation. In the discussion contained in reference 4 this tendency to oscillate was attributed, at least in part, to the omission of gravity considerations in the bank-angle-error computation.

An appropriate bank-angle-error equation for the present system would differ from equation (1) only in the details of the gravity-term expressions; therefore, it was desirable that the bank-angle-error computer be flexible so that considerable latitude could be provided for variations in the magnitude of the so-called gravity terms. In addition, it was desirable that the rather complicated circuitry associated with mechanizing an arc tangent function be avoided. As a result the following equation, using small-angle approximations of equation (2), was chosen for the bank-angle-error computation:

$$\phi_{\epsilon, g} = \frac{\sigma_D - K_2 \phi}{|\sigma_E| + K} \quad (4)$$

If the gravity terms are omitted from equation (4), the expression becomes

$$\phi_{\epsilon} = \frac{\sigma_D}{|\sigma_E|} \quad (5)$$

The extent to which equations (4) and (5) can be used to approximate the expression of equations (2) and (3) is discussed in the following sections.

Gravity Terms Omitted in Bank-Angle-Error Computation

The curve plotted in figure 20 representing equation (5) shows that this expression provides good agreement with $\tan^{-1} \frac{\sigma_D}{\sigma_E}$ for about the first 30° of bank-angle error but becomes widely different at higher angles. The trend toward very large signals at large bank-angle errors was not considered a serious problem because it was expected that saturation of components within the actual system would generally limit the signal levels in this range. The absolute value of σ_E was used to avoid a discontinuity at 90° of bank-angle error and to keep the sign of the computed signal the same as the desired direction of roll. The decrease in computed signal from a maximum at 90° to zero at 180° was considered a desirable feature because, as pointed out in reference 8, it precludes large roll commands when the bank-angle error is close to $\pm 180^\circ$ and allows the interceptor to reduce the tracking error by pitching down. Because of the indeterminateness that exists in the expression $\frac{\sigma_D}{|\sigma_E|}$ when the errors become zero, however, it is desirable to include the constant K in the denominator in order to decrease the level of the computed signal in the region of small errors and to avoid this indeterminateness. The curve in figure 20 represents $\frac{\sigma_D}{|\sigma_E| + K}$ for specified values of σ_R and K and is seen to provide reasonable agreement with $\tan^{-1} \frac{\sigma_D}{\sigma_E}$ over a moderate range. A constant value of σ_R was specified in this figure because the value of the expression varies with the magnitude of σ_R as well as with the magnitude of K . The importance of K and σ_R is shown in figure 21 for bank-angle errors of 15° , 30° , and 45° . Figure 21 shows the reduction in computed signal associated with different values of K as the resultant error approaches zero. At very large radial errors the computed signal becomes independent of K .

Gravity Terms Included in Bank-Angle-Error Computation

For the case where the effects of the gravitational field are considered, all the terms of equation (4) are used for the computation.

Comparison of this equation with the solution as given by equation (2) shows a correspondence between individual terms. By adjusting the values of K and K_2 in equation (4), this equation can be made to be a good approximation of equation (2) over a fairly wide range of ϕ . As may be seen in figure 22 the agreement between the computation using equation (2) and the approximate computation of equation (4) is good over a fairly wide range of bank-angle positions of the target relative to the interceptor and appears to be practically independent of the magnitude of radial tracking error. The agreement continues to be fairly good as the interceptor assumes various bank angles (with the greater differences occurring at the high bank angles coupled with high values of target relative-bank-angle position).

APPENDIX B

EQUATIONS UTILIZED IN SIMPLIFIED ANALYTICAL STUDY OF
INTERCEPTOR RESPONSE FOR TRACKING ERRORS

The equations that were utilized in the analytical studies of interceptor response to tracking errors as described in the text of this report are as follows:

$$\sigma_E = \sigma_{XZ_n} \cos \phi_n + \sigma_{XY_n} \sin \phi_n$$

$$a_E = K_E \sigma_E + g$$

$$\Delta \sigma_{XZ} = \left(\frac{a_E}{V} \cos \phi_n - \frac{g}{V} \right) \Delta t$$

$$(\sigma_{XZ})_{n+1} = \sigma_{XZ_n} + \Delta \sigma_{XZ_n}$$

$$\sigma_D = \sigma_{XZ_n} \sin \phi_n - \sigma_{XY_n} \cos \phi_n$$

$$\phi_\epsilon = \tan^{-1} \frac{\sigma_D}{\sigma_E} \quad (\text{gravity terms omitted in computer})$$

$$\phi_{\epsilon, g} = \tan^{-1} \frac{\sigma_D - K_1 \sin \phi_n}{|\sigma_E| + K_1 \cos \phi_n} \quad (\text{gravity terms included in computer})$$

$$\Delta \sigma_{XY_n} = \frac{a_E}{V} \sin \phi_n \Delta t$$

$$(\sigma_{XY})_{n+1} = \sigma_{XY_n} + \Delta \sigma_{XY_n}$$

$$\dot{\phi}_n = K_D \phi_\epsilon \quad \text{or} \quad K_D \phi_{\epsilon, g}$$

$$\phi_{n+1} = \phi_n + \Delta\phi_n$$

$$\Delta\phi_n = \dot{\phi}_n \Delta t$$

In some of the runs first-order time lags were used in both the roll and normal-acceleration response of the interceptor so that

$$\ddot{\phi}_n = \frac{1}{\tau_1} (K_D \phi_\epsilon - \dot{\phi}_n)$$

$$\ddot{\gamma}_{A_n} = \frac{1}{\tau} \left(\frac{K_E \sigma_E}{V} - \dot{\gamma}_{A_n} \right)$$

where $K_D \phi_\epsilon$ represents the command roll rate and $K_E \sigma_E$ represents the command normal acceleration. In these runs it was assumed that the acceleration terms $\ddot{\phi}_n$ and $\ddot{\gamma}_{A_n}$ remained constant over the time interval Δt , and average values of $\dot{\phi}$ and $\dot{\gamma}$ were calculated to apply for each time interval.

The analytical procedure assumed that constant angular rates were maintained during the time interval between calculated points. This time interval was kept small (usually 0.1 second) in order to improve the accuracy of the calculation. It was further assumed that the tracking problems involved an infinite range so that only the flight-path angles and roll motions of the interceptor needed to be considered. A sketch of the tracking problem as assumed for this analytical study is presented in figure 8.

REFERENCES

1. Mathews, Charles W.: Study of the Attack of an Automatically Controlled Interceptor on a Maneuvering Bomber With Emphasis on Proper Coordination of Lift-Acceleration and Roll-Angle Commands During Rolling Maneuvers. NACA RM L54E27, 1954.
2. Mathews, Howard F., and Schmidt, Stanley F.: A Comparison of the Maneuvering Performance of a Monowing Versus a Cruciform Missile. NACA RM A55D13, 1955.
3. Mathews, Charles W., Cheatham, Donald C., and Kyle, Howard C.: A Flight and Analytical Study of Methods for Reducing Automatic-Interceptor Tracking Errors Caused by Target Maneuvers. NACA RM L56D23, 1956.
4. Sherman, Windsor, L., and Schy, Albert A.: Theoretical Investigation of the Attack Phase of an Automatic Interceptor System at Supersonic Speeds With Particular Attention to Aerodynamic and Dynamic Representation of the Interceptor. NACA RM L56J08, 1957.
5. Lusian, R. G., and Blattner, C. J.: F2H-3 Airframe Dynamic Lateral and Longitudinal Stability Characteristics Determined From Flight Test - Automatic Fire Control Program. Rep. No. 3091 (Contract No. NOa(s)-51-023), McDonnell Aircraft Corp., Oct. 22, 1953.
6. Blattner, C. J., and Golding, N. J., Jr.: Automatic Fire Control System - F2H-3 Banshee. Rep. No. 3440 (Contract NOa(s) 51-023, McDonnell Aircraft Corp., Oct. 15, 1954.
7. Cheatham, Donald C., and Mathews, Charles W.: A Flight and Analog Study of the Effect of Elevating the Radar-Boresight Axis Upon Stability and Tracking Performance of an Automatically Controlled Interceptor. NACA RM L57G24, 1957.
8. Triplett, William C.: Considerations Involved in the Design of a Roll-Angle Computer for a Bank-to-Turn Interceptor. NACA RM A55D18a, 1955.



TABLE I

DIMENSIONAL AND MASS CHARACTERISTICS OF FLIGHT-TEST VEHICLE

| | |
|---|---------------------------|
| Overall length, ft | 48.04 |
| Wing: | |
| Span, ft | 41.70 |
| Area, sq ft | 294.0 |
| Airfoil section, wing-fold | NACA 65 ₁ -212 |
| Incidence, deg | -0.5 |
| Aspect ratio | 5.9 |
| Dihedral, deg | 3.0 |
| Mean aerodynamic chord, in. | 88.4 |
| Leading-edge sweepback, deg | 0 |
| Ailerons: | |
| Mean chord rearward of hinge line, ft | 1.24 |
| Span, percent b/2 | 32.8 |
| Horizontal-tail surfaces: | |
| Total area, sq ft | 70.1 |
| Span, ft | 17.8 |
| Elevator area rearward of hinge line, sq ft | 18.7 |
| Distance from 0.256c̄ to elevator hinge line, ft | 24.0 |
| Dihedral, deg | 10.0 |
| Vertical-tail surfaces: | |
| Total area, sq ft | 39.9 |
| Rudder area rearward of hinge line, sq ft | 9.6 |
| Distance from 0.256c̄ to rudder hinge line, ft | 22.2 |
| Approximate weight at flight-test conditions, lb | 20,700 |
| Relative density (20,000 ft) | 41.6 |
| Center-of-gravity station, percent c̄ | 25.7 |
| Moment of inertia about X-axis, I _X , slug-ft ² | 15,145 |
| Moment of inertia about Y-axis, I _Y , slug-ft ² | 41,677 |
| Moment of inertia about Z-axis, I _Z , slug-ft ² | 54,616 |



TABLE II

AUTOMATIC-CONTROL GAINS CONSIDERED NORMAL FOR THE FLIGHT AND
ANALOG-SIMULATOR TESTS OF THE AUTOMATIC-INTERCEPTOR PROBLEM

| | | | |
|----------------------------------|--------------------|---|------|
| Deflection-error gain | K_{σ_D} | $\frac{\text{deg aileron}}{\text{deg deflection error}}$ | 20 |
| Deflection-error integrator gain | K_I | $\frac{(\text{deg aileron})/\text{sec}}{\text{deg deflection error}}$ | 0 |
| Bank-angle-feedback gain | K_{ϕ} | $\frac{\text{deg aileron}}{\text{deg bank attitude}}$ | 1.0 |
| Roll-rate-feedback gain | $K_{\dot{\phi}}$ | $\frac{\text{deg aileron}}{\text{deg/sec roll rate}}$ | 0.25 |
| Elevation-error gain | K_{σ_E} | $\frac{\text{deg elevator}}{\text{deg elevation error}}$ | 6.5 |
| Pitch-rate-feedback gain | $K_{\dot{\theta}}$ | $\frac{\text{deg elevator}}{\text{deg/sec pitch rate}}$ | 1.5 |

CONFIDENTIAL



Figure 1.- Side view of automatic interceptor used in flight tests. L-57-2329

CONFIDENTIAL

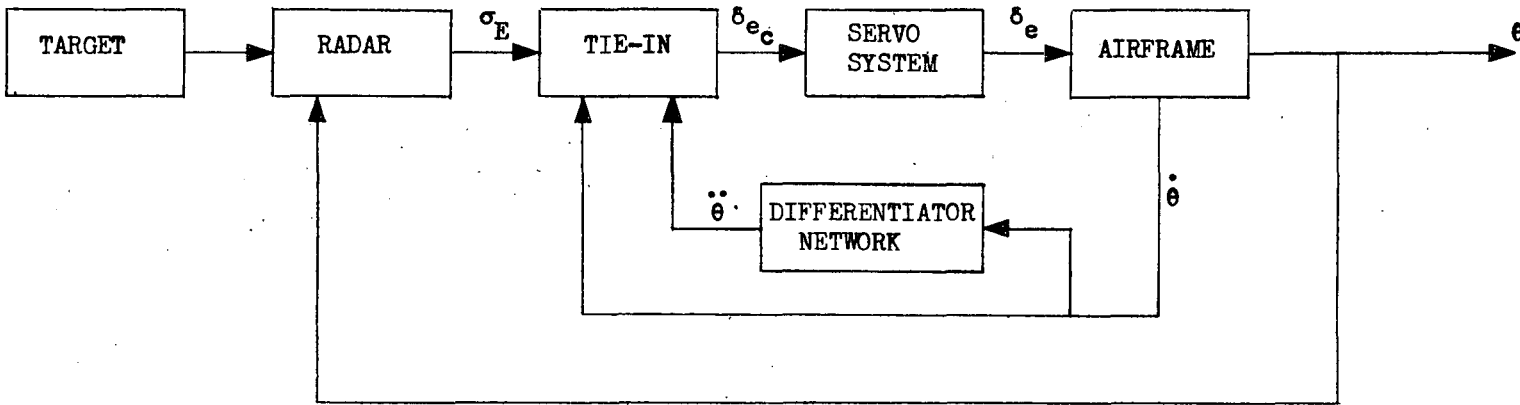
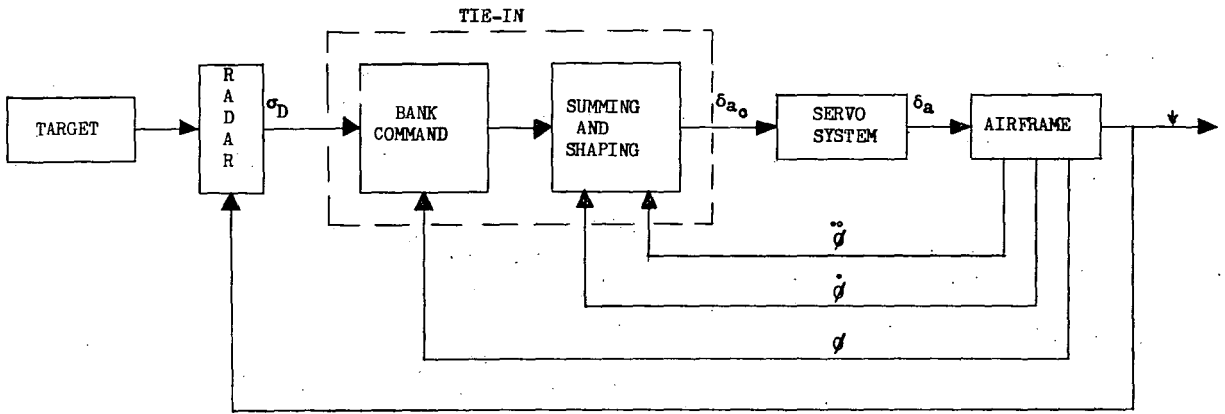
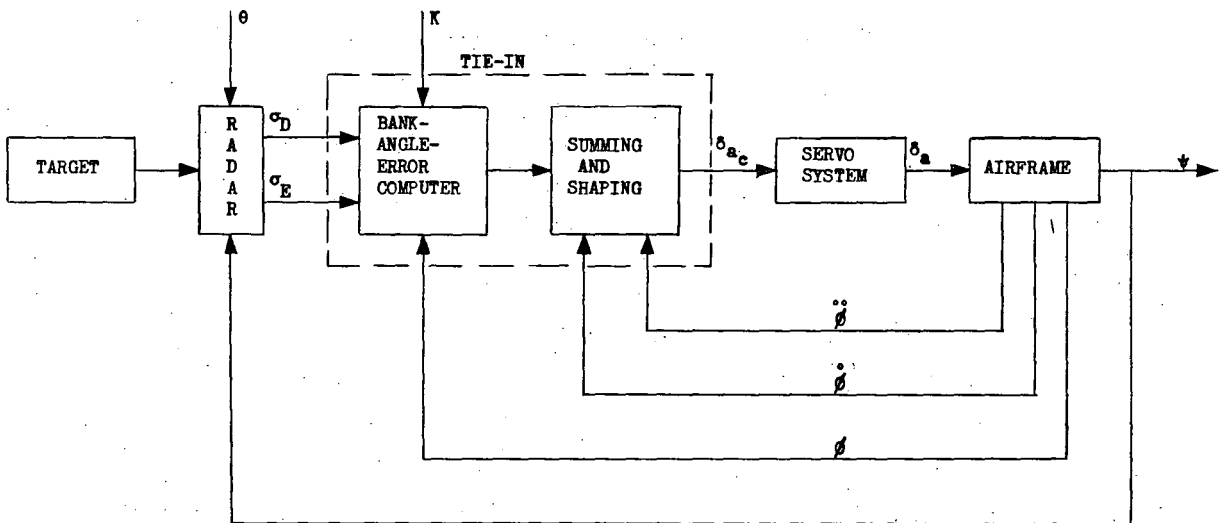

Figure 2.- Schematic diagram of elevation channel.



(a) System before modification.



(b) System as modified to include bank-angle-error computer.

Figure 3.- Schematic diagram of lateral channel.

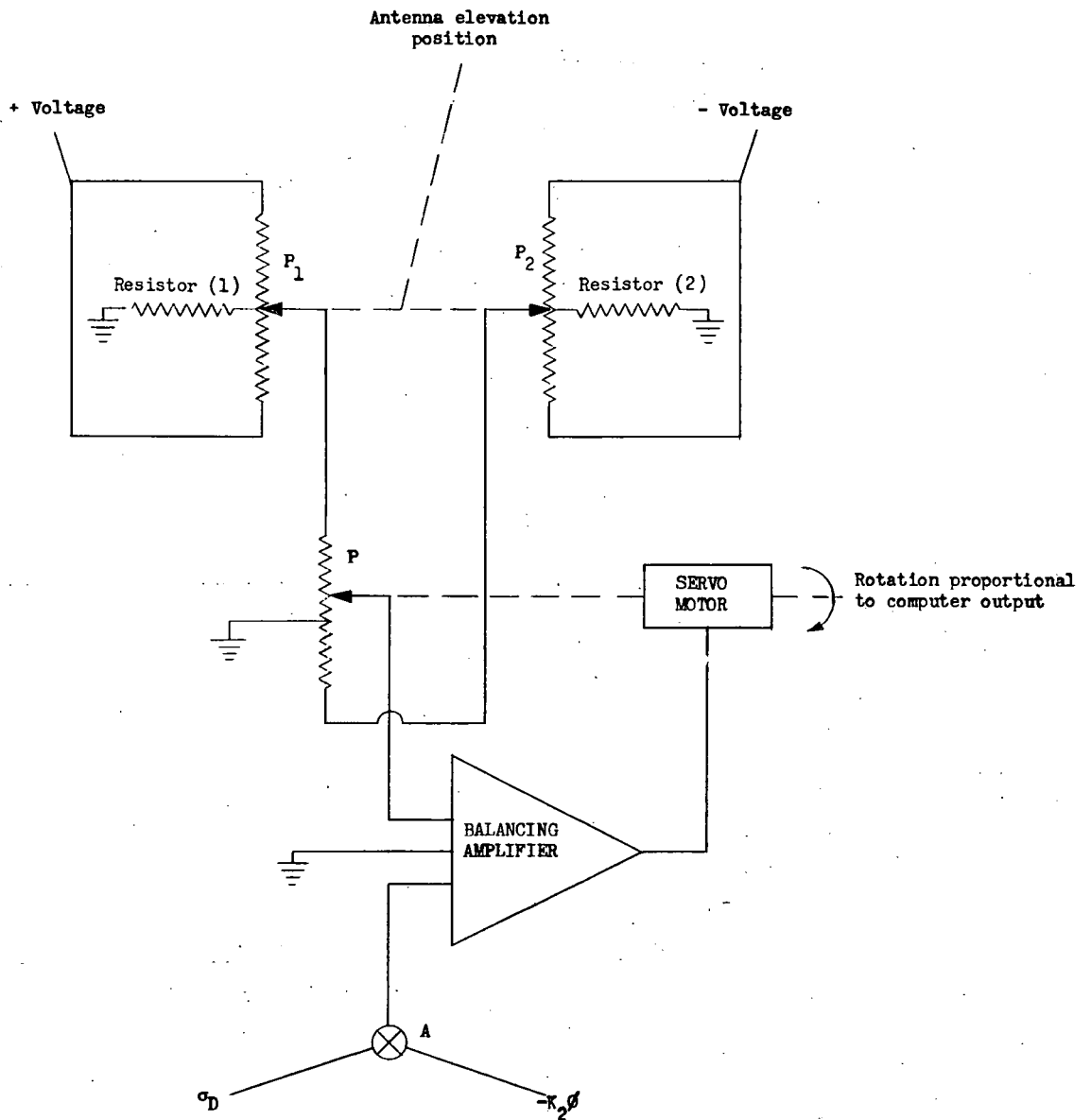

Figure 4.- Schematic diagram of bank-angle-error computer.



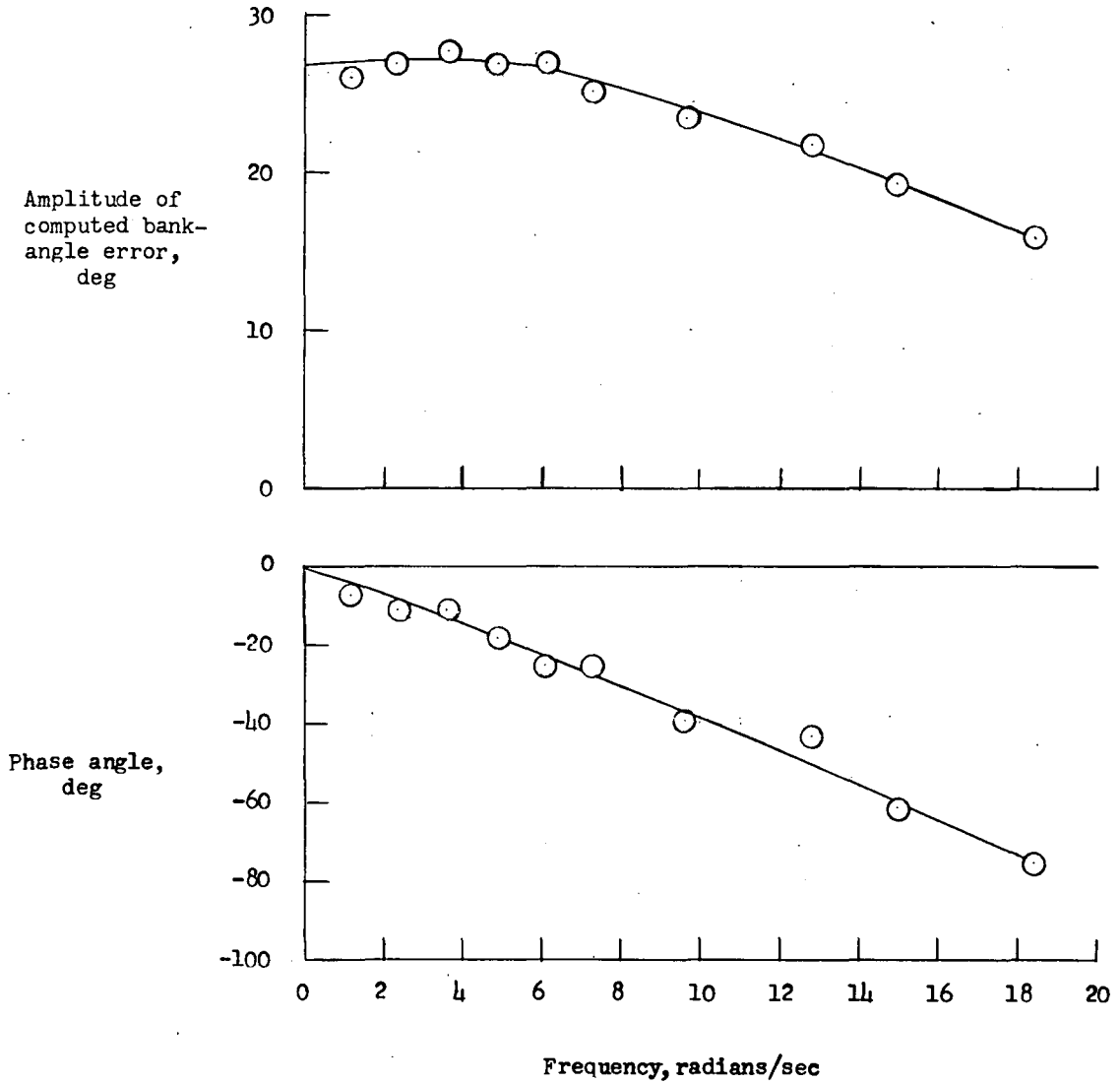

Figure 5.- Typical variation with frequency of amplitude of computed bank-angle error and phase angle of bank-angle-error computer used in flight-test system. $\sigma_R = 0.707^\circ$; $K = \frac{2^\circ}{3}$; $\phi_{\epsilon, \text{input}} = 45^\circ$.

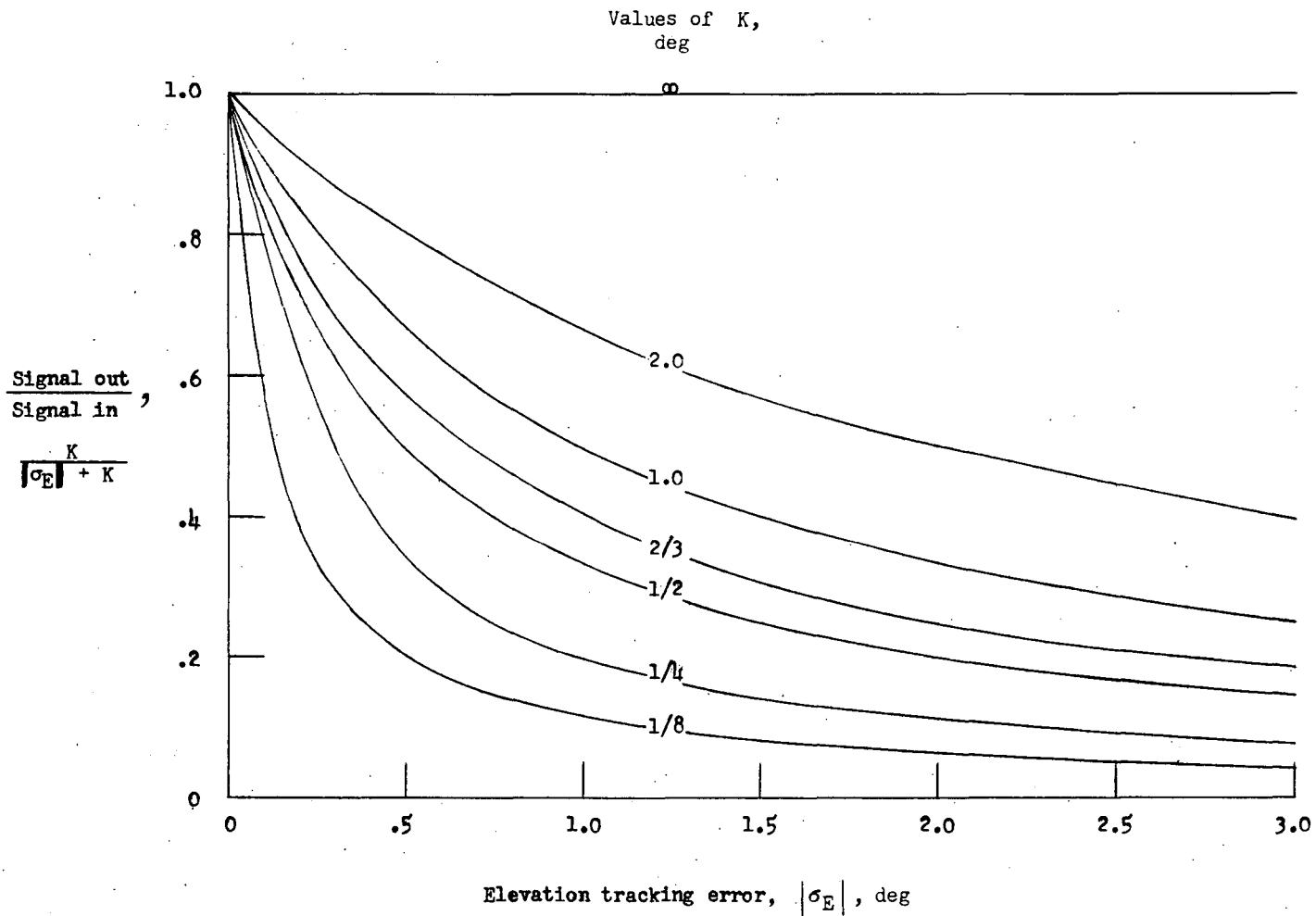

Figure 6.- Variation of function $\frac{K}{|\sigma_E| + K}$ with elevation tracking error $|\sigma_E|$ for different values of K.



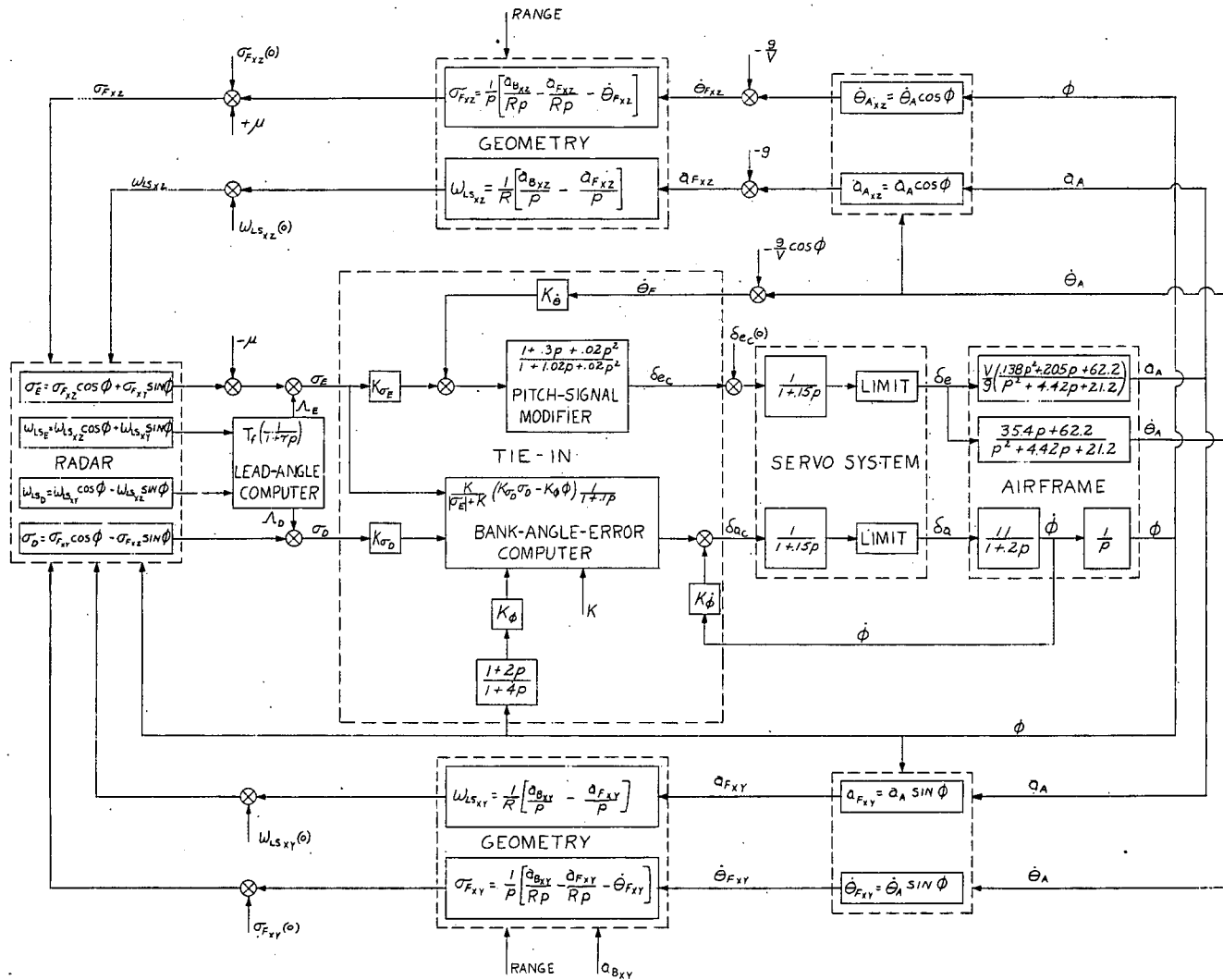

Figure 7.- Schematic diagram of interceptor problem as set up on analog simulator.

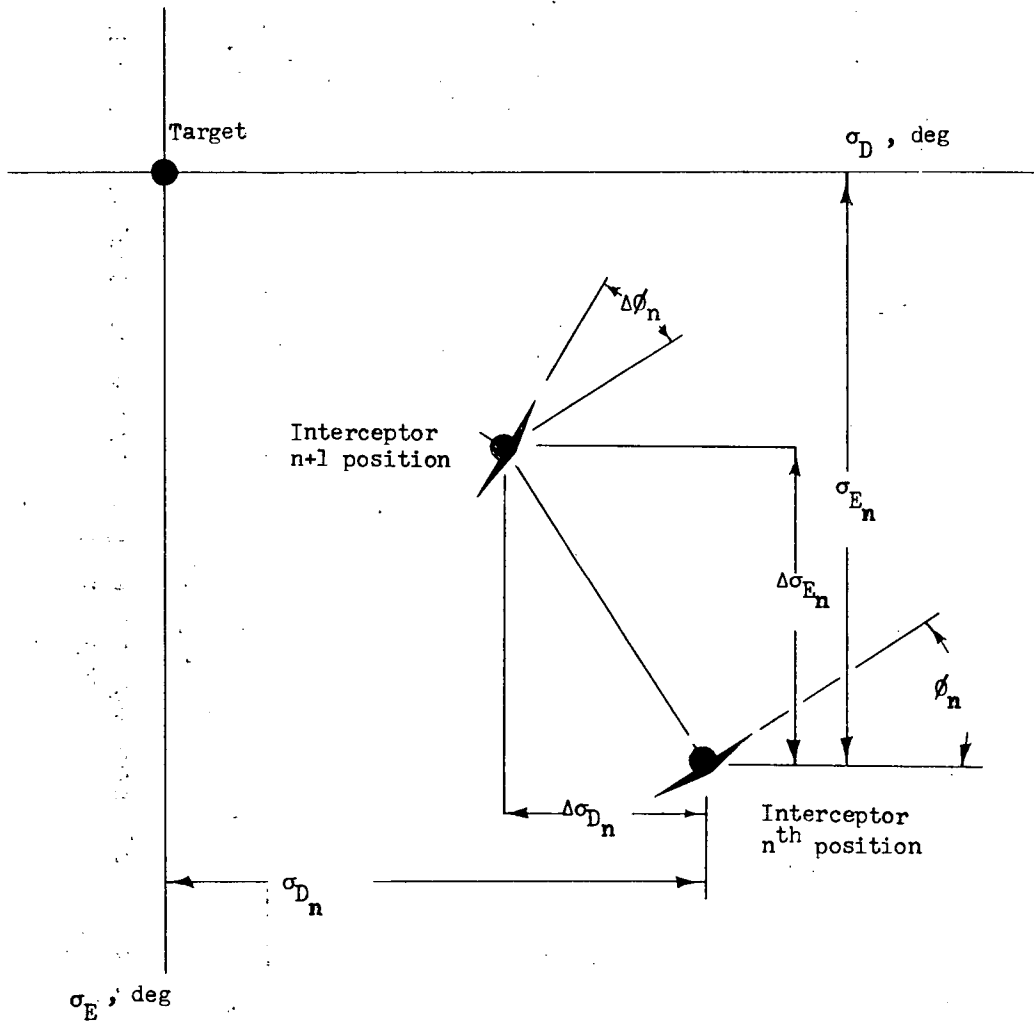

Figure 8.- Sketch of interceptor tracking problem as assumed for analytical studies.

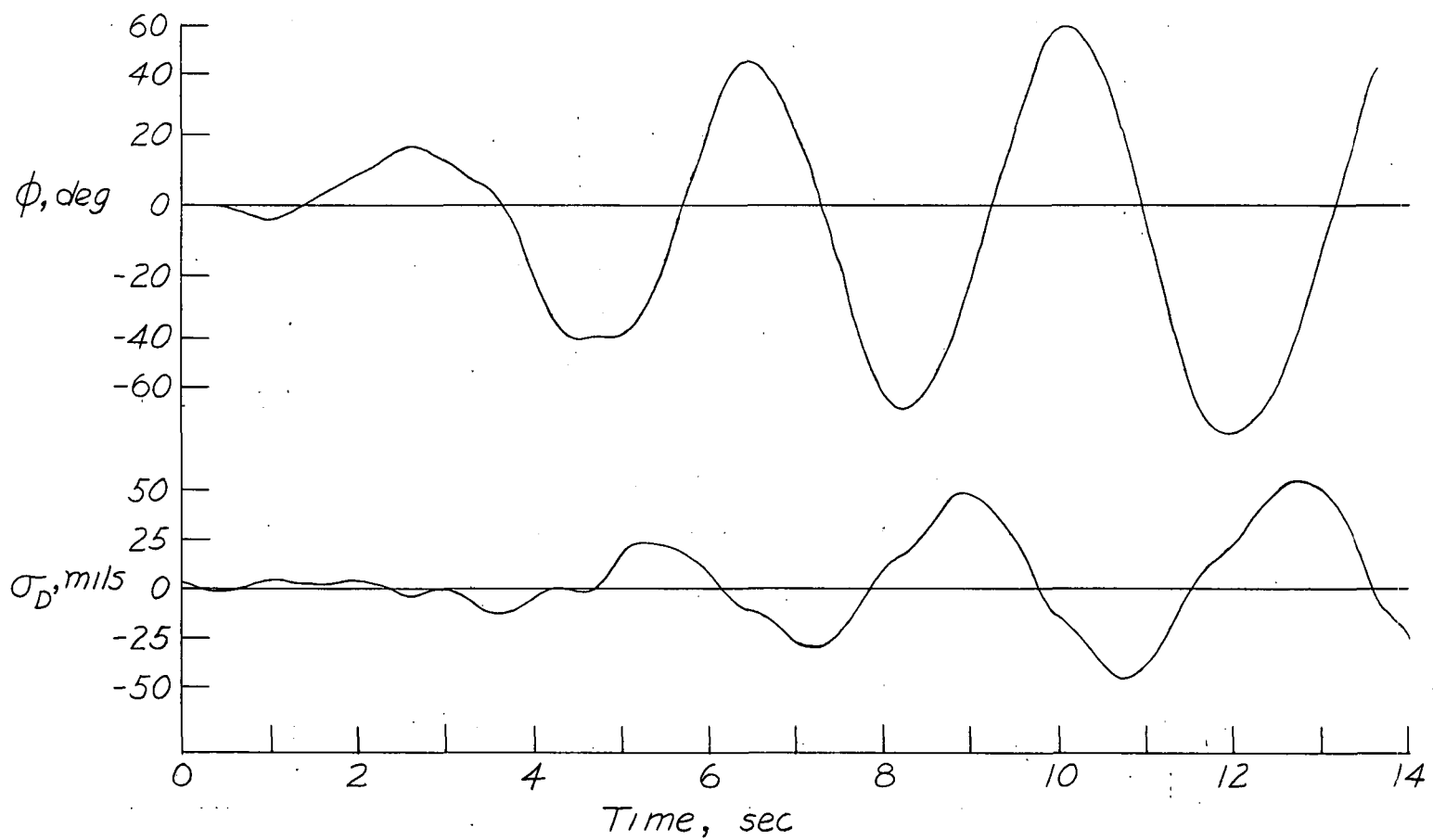

Figure 9.- Flight-test response of interceptor when gravity was not included in bank-angle-error computation.

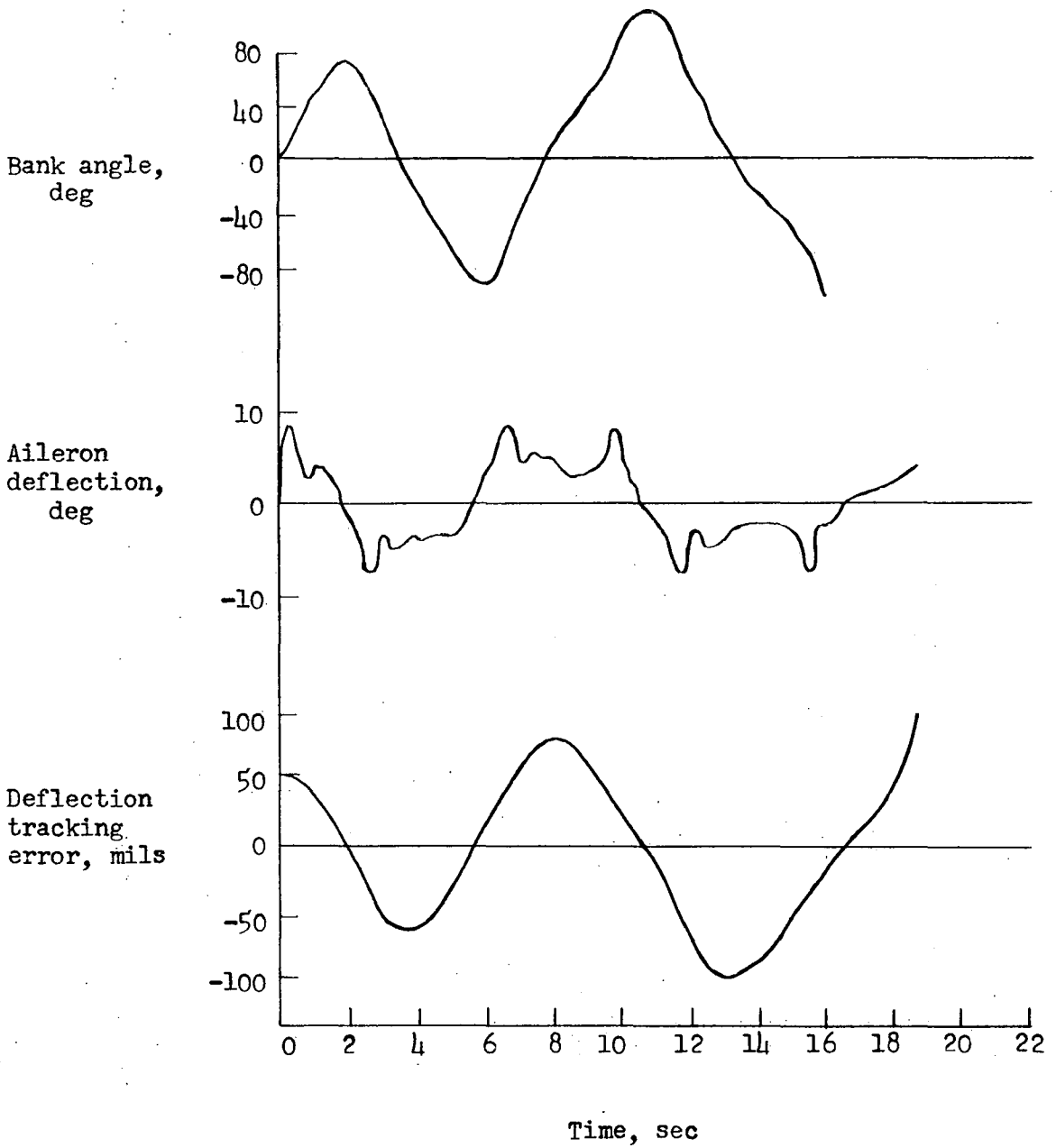

Figure 10.- Response of analog simulation of interceptor to an initial deflection tracking error when gravity was not included in bank-angle error computation. $K = \frac{1}{4}$.



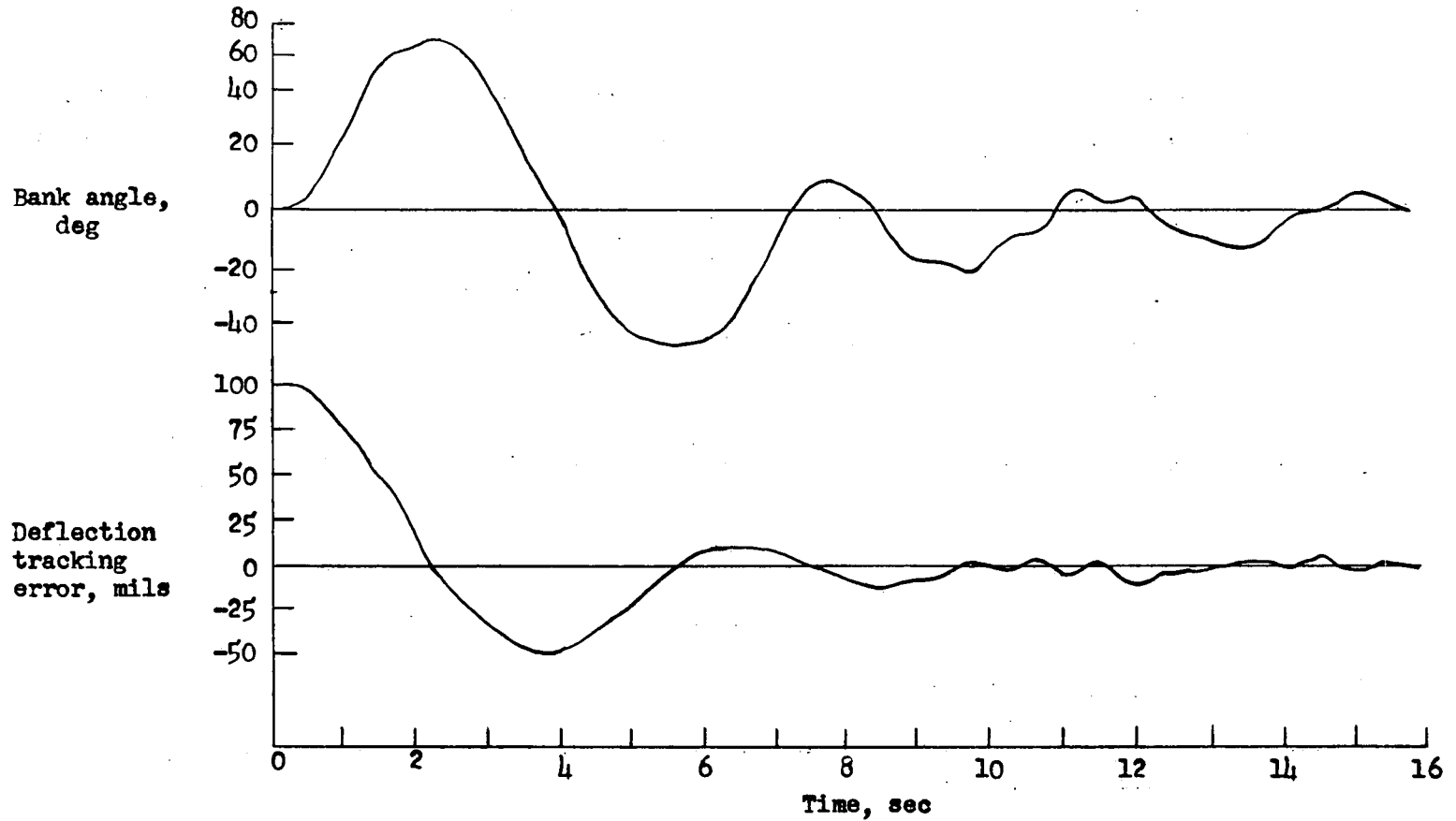

Figure 11.- Time history of interceptor response during flight tests following an engagement with an initial deflection tracking error. Gain on gravity term in bank-angle-error computer is approximately $4\frac{1}{2}$ times as high (static value) as would be required for a simple gravity consideration.

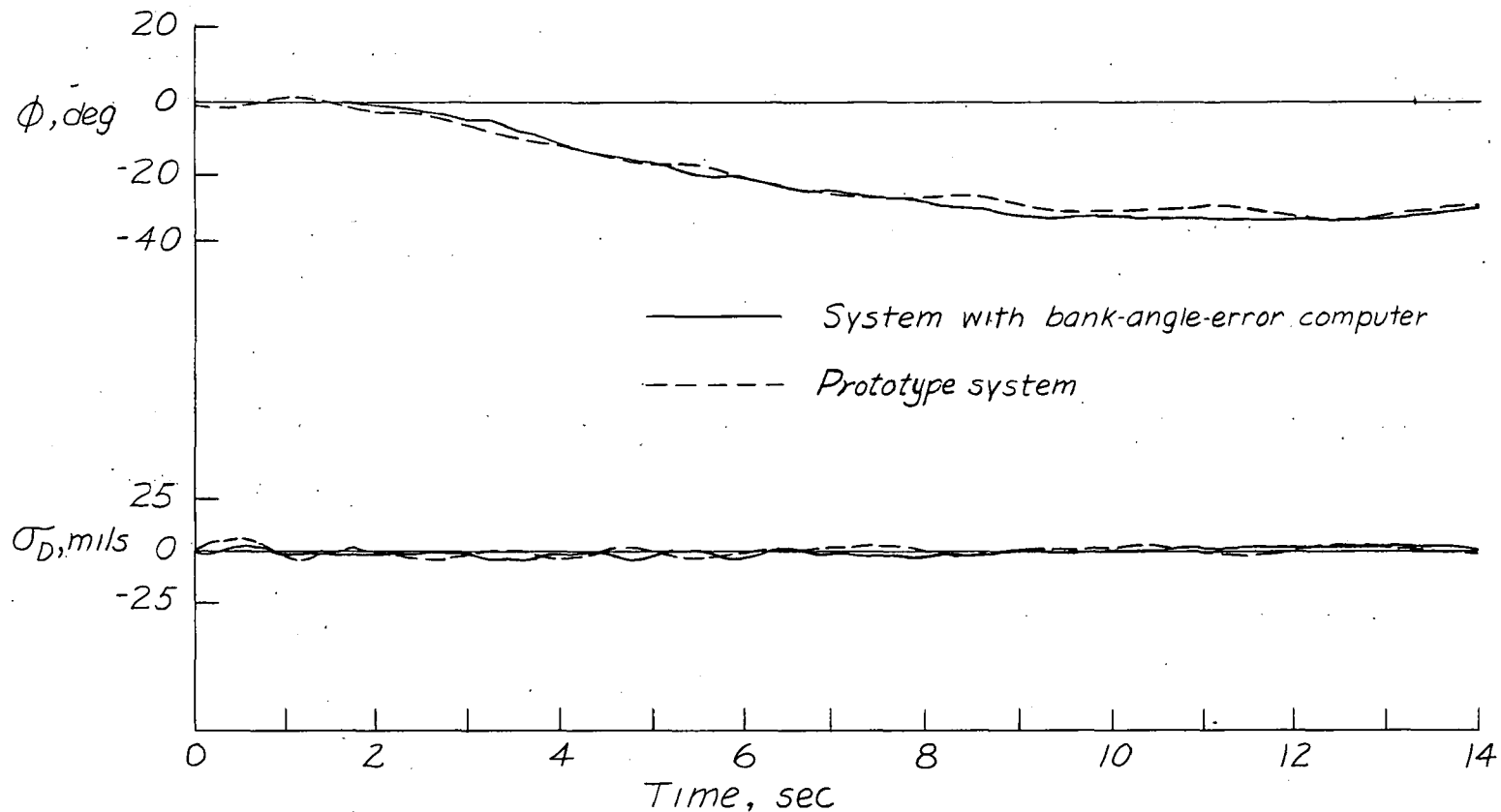

Figure 12.- Flight-test response to target turn. Radar-boresight axis raised $3\frac{1}{2}^{\circ}$ above armament-datum line for both systems. No gravity consideration in the bank-angle-error computer.

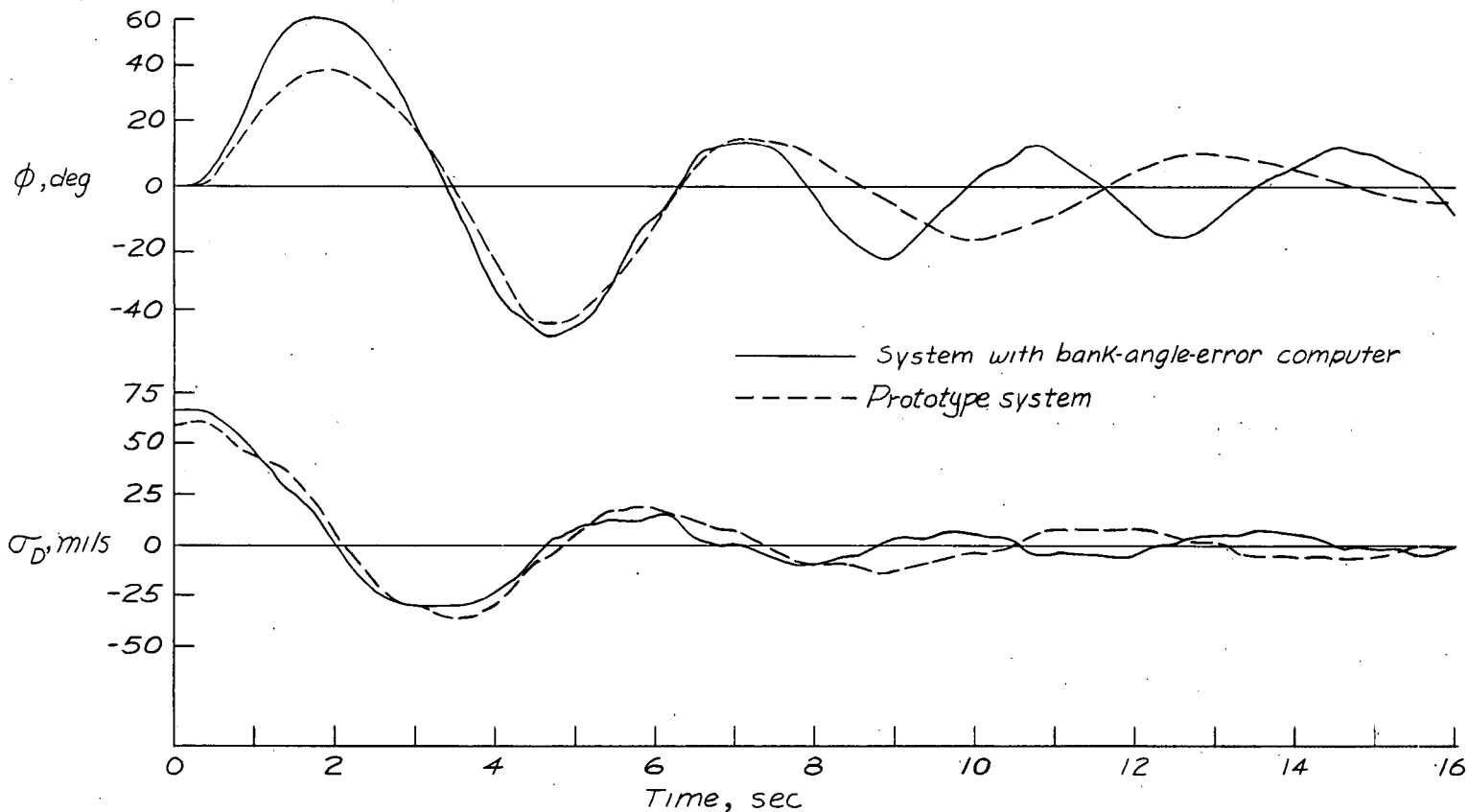

Figure 13.- Comparison of flight-test response of modified and original interceptor systems utilizing similar gains.

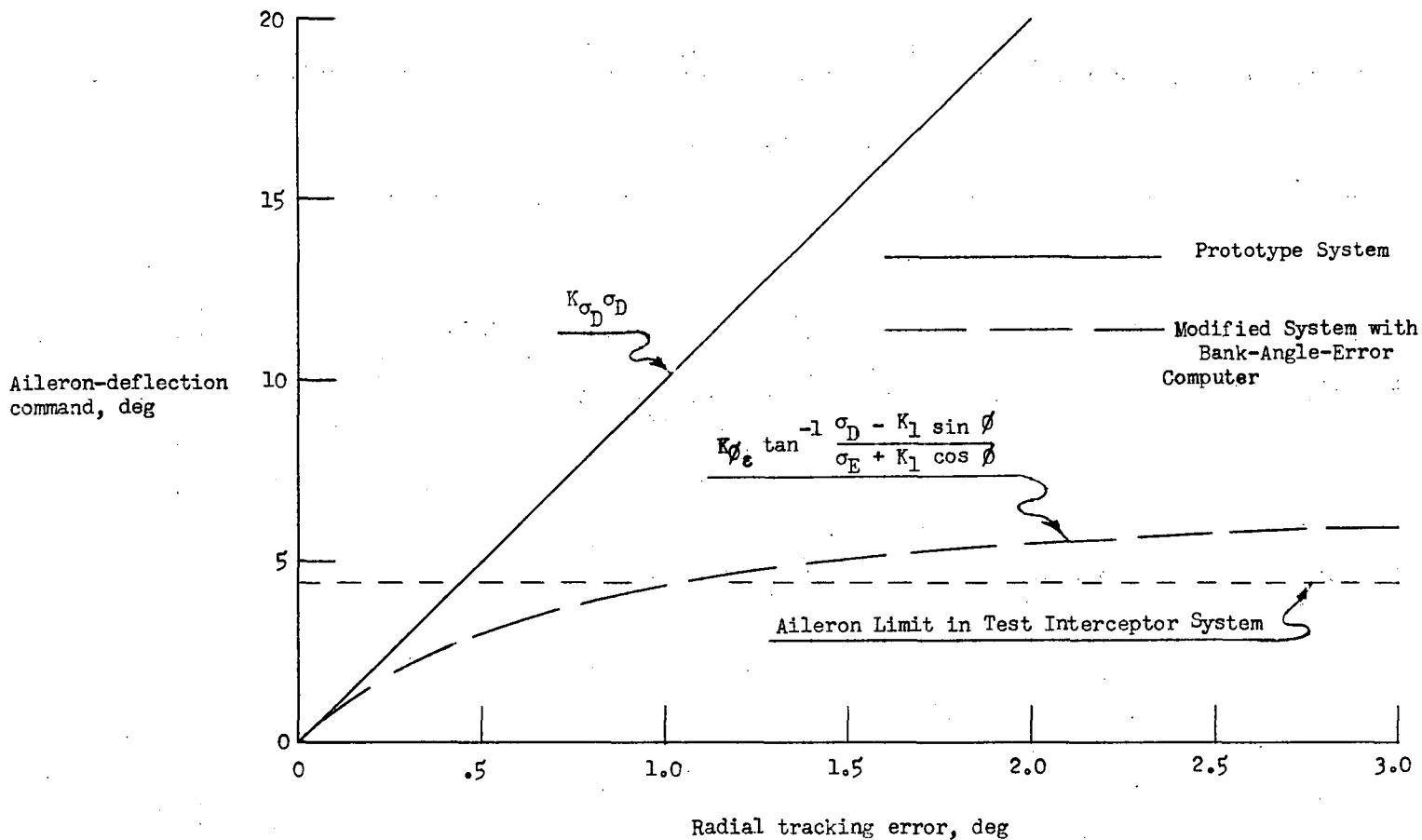

Figure 14.- Variation with radial tracking error of the aileron-deflection command that is generated by the bank-angle-error computer and the corresponding command generated in the prototype deflection channel. $\phi_e = 30^\circ$.

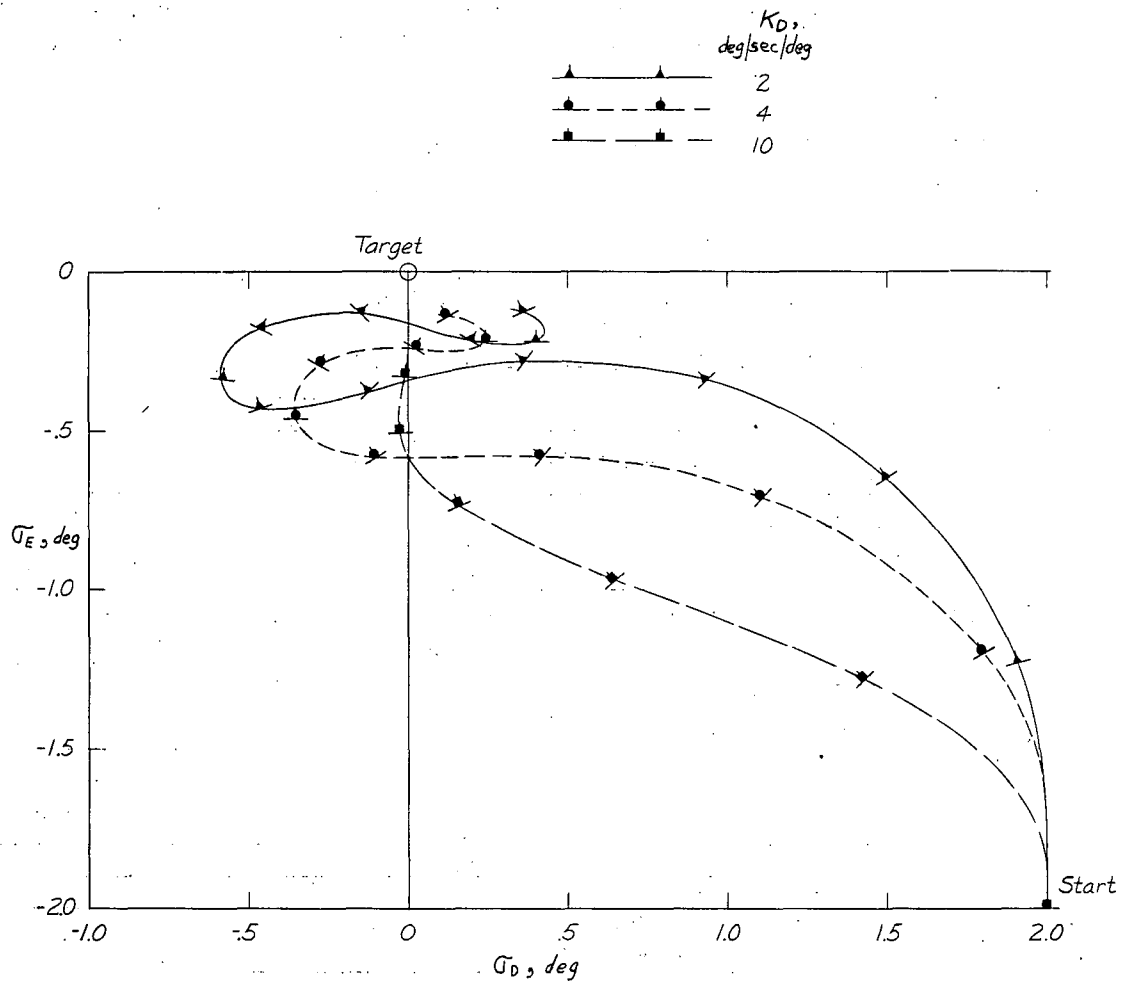

Figure 15.- Response of analytical system showing effect of variations in deflection-channel gain. No gravity in bank-angle-error computation; $K_E = 0.87\text{g/deg } \sigma_E$; time between data symbols, 0.2 second.



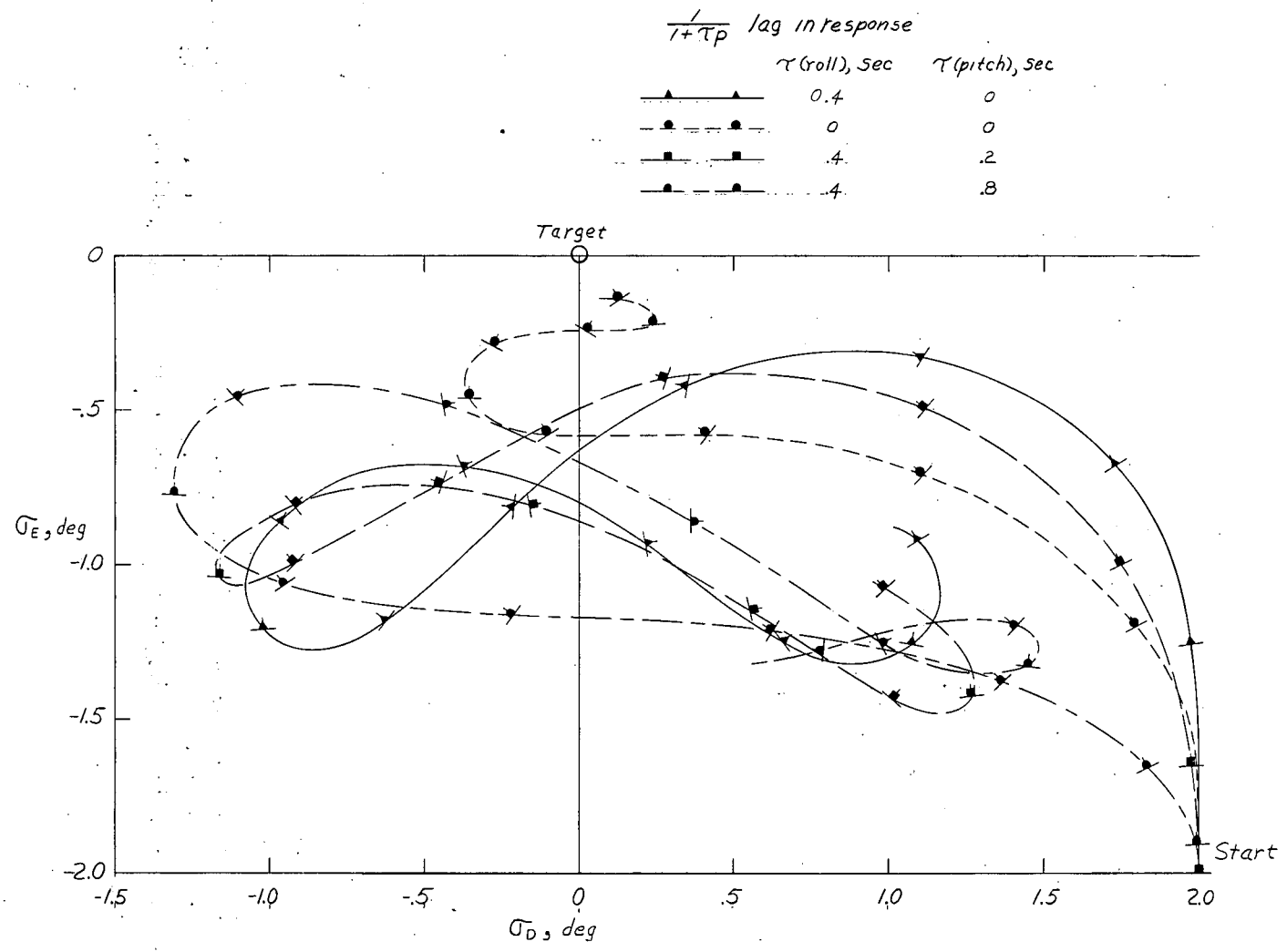

Figure 16.- Response of analytical system showing effect of lags in roll and pitch response. No gravity in bank-angle-error computation; time between data symbols, 0.2 second.



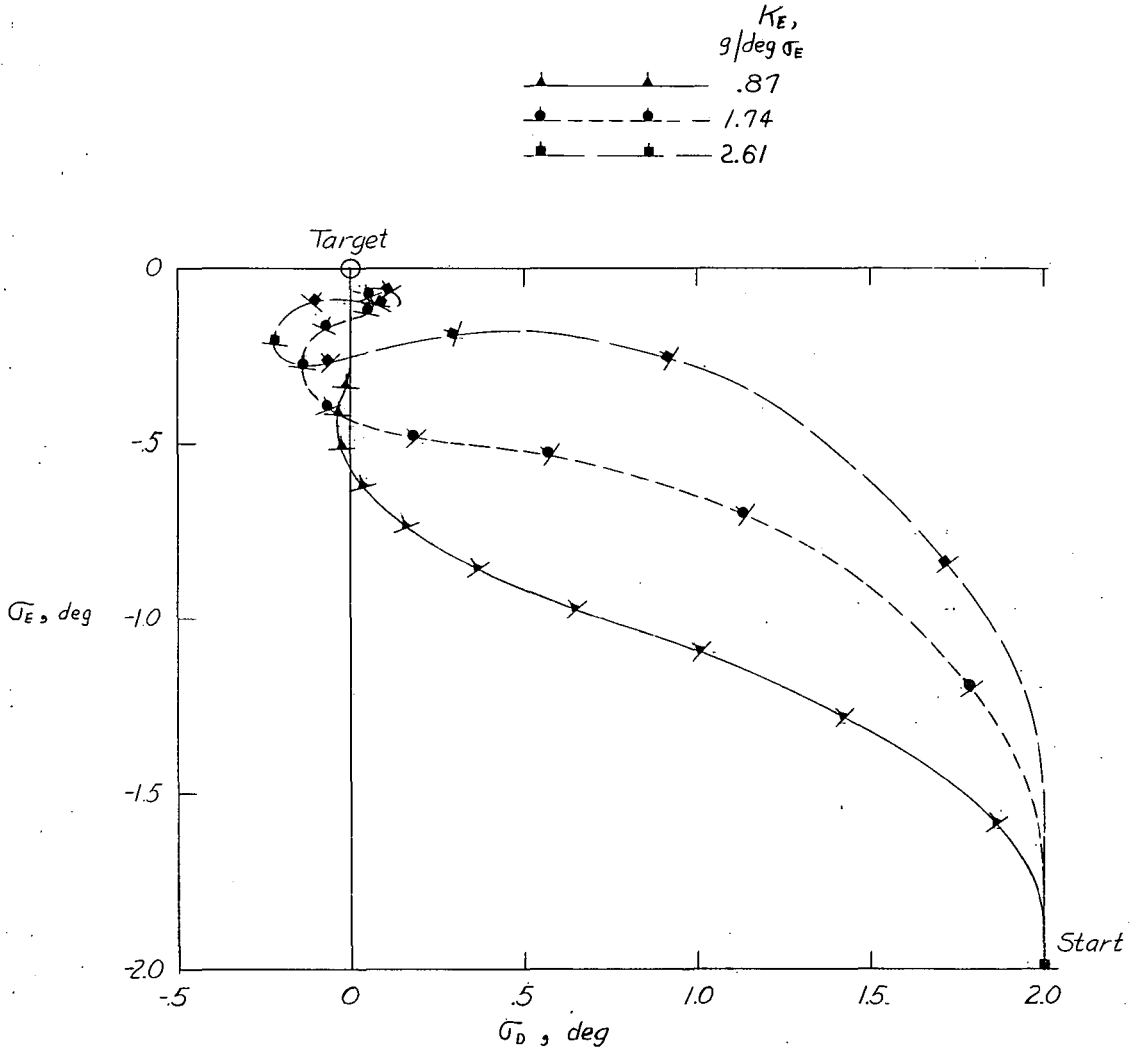

Figure 17.- Response of analytical system showing effects of variations in elevation-channel gain. No gravity included in bank-angle-error computation; $K_D = 4 \text{ deg/sec/deg}$; time between data symbols, 0.2 second.



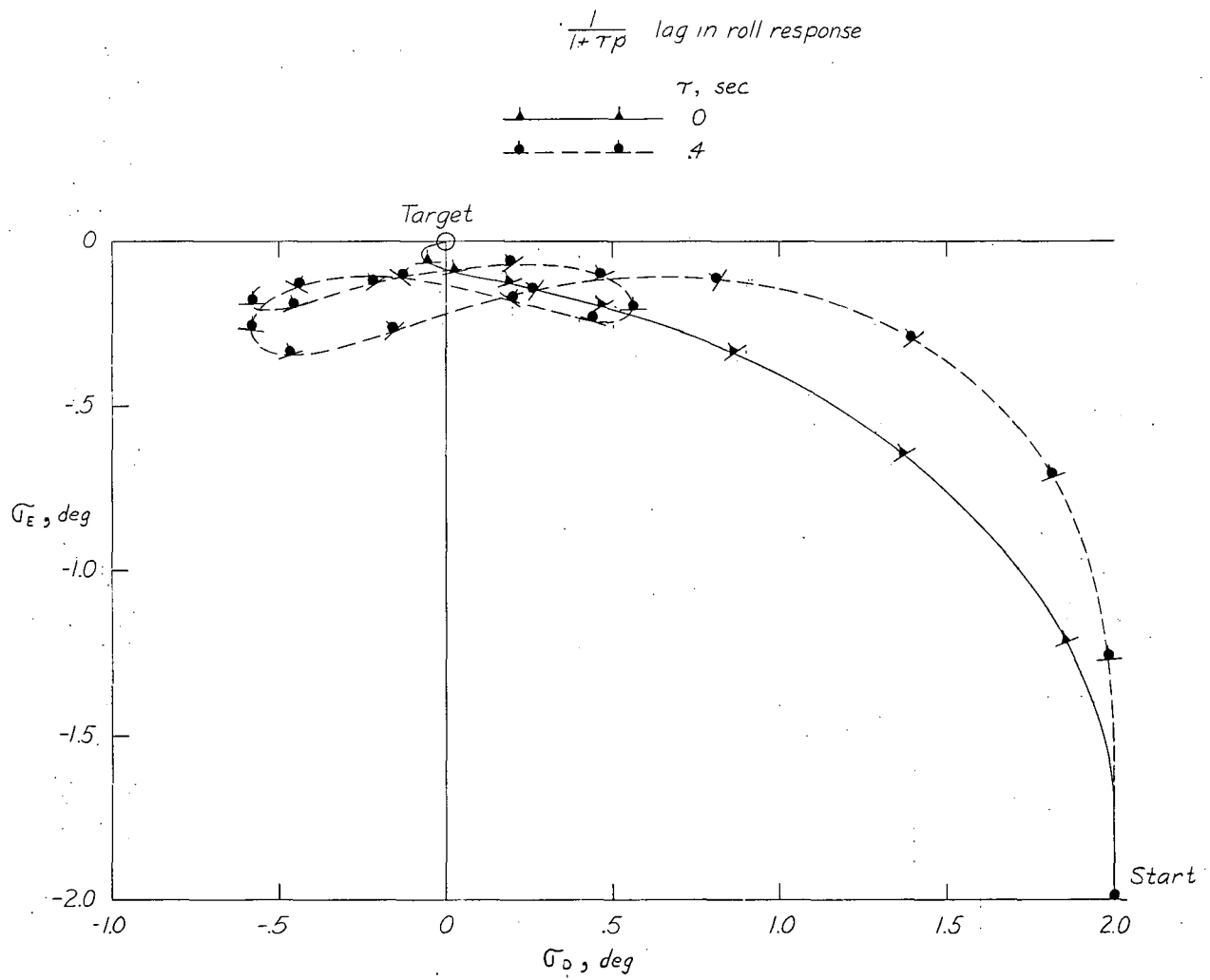
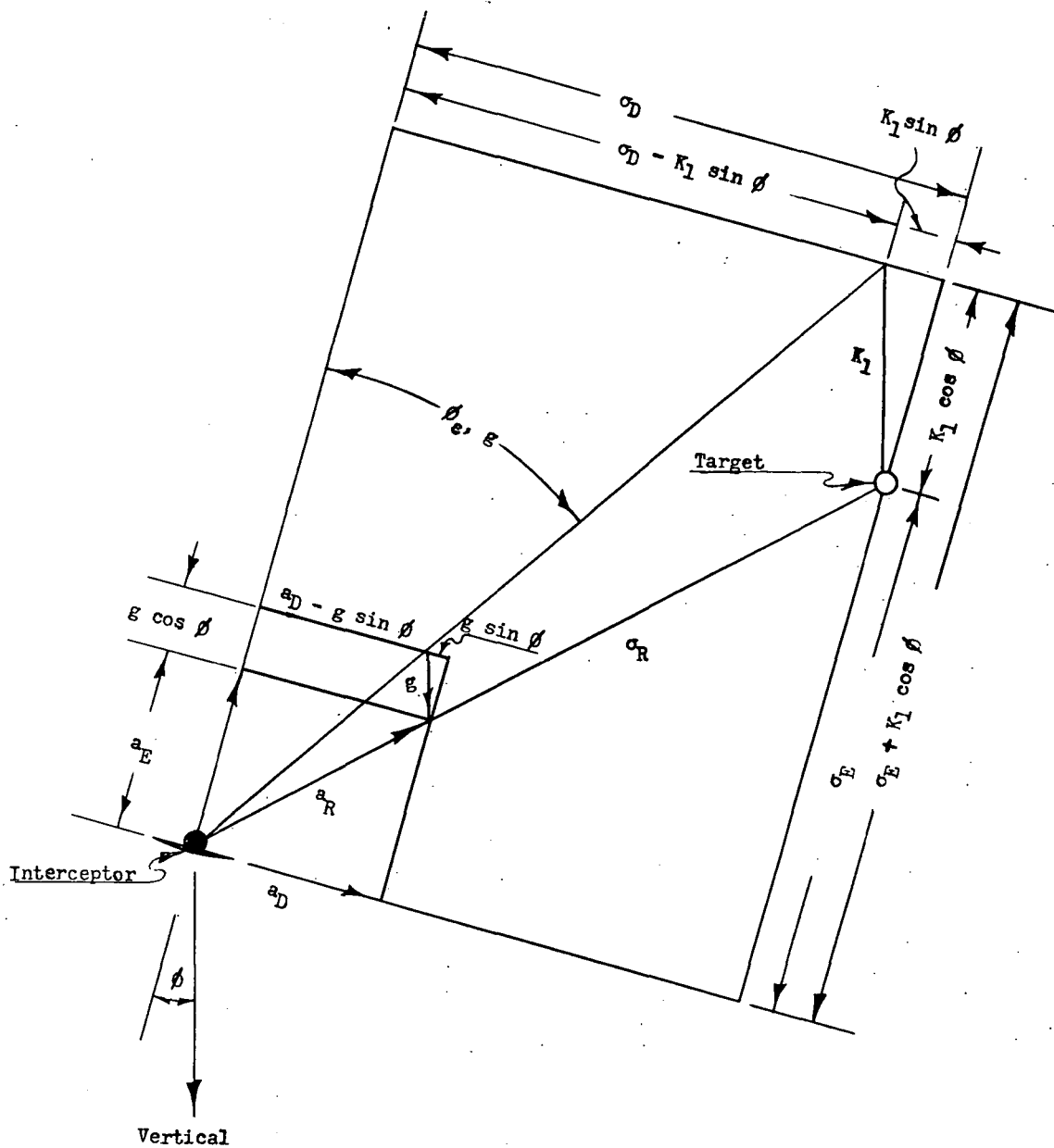

Figure 18.- Response of analytical system showing effect of including gravity considerations in bank-angle-error computation; time between data symbols, 0.2 second.





(a) Gravity included. $\frac{a_E}{\sigma_E} = \frac{a_D}{\sigma_D} = \frac{a_R}{\sigma_R} = \frac{g}{K_1}$.

Figure 19.- Tracking diagram of bank-angle-error computation.



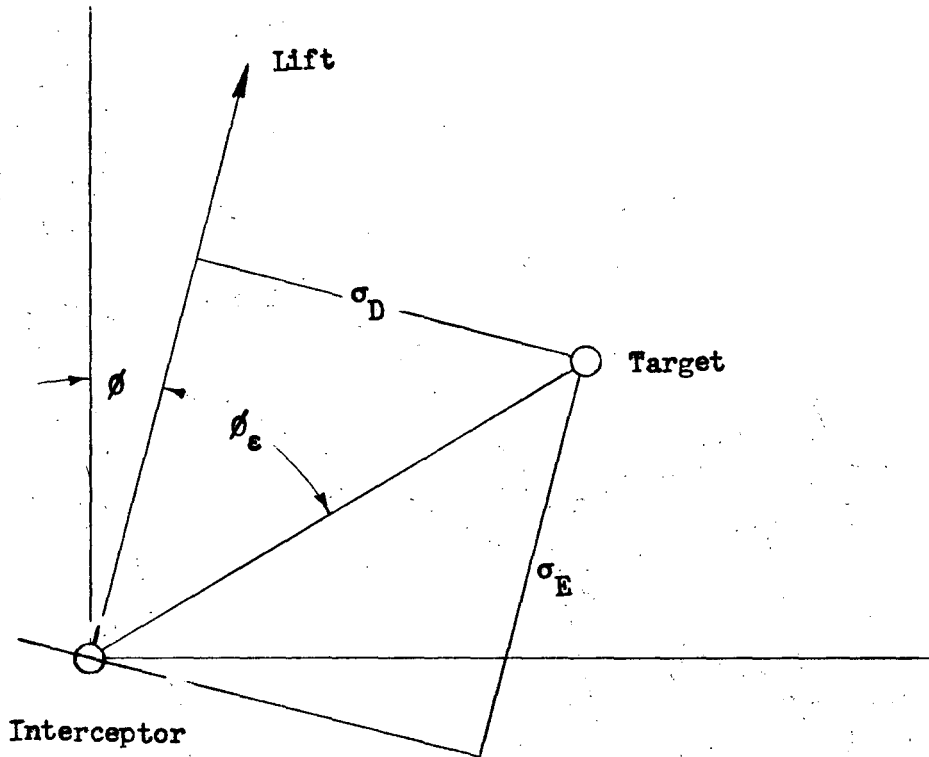

(b) Gravity omitted. $\phi_\epsilon = \tan^{-1} \frac{\sigma_D}{\sigma_E}$.

Figure 19.- Concluded.

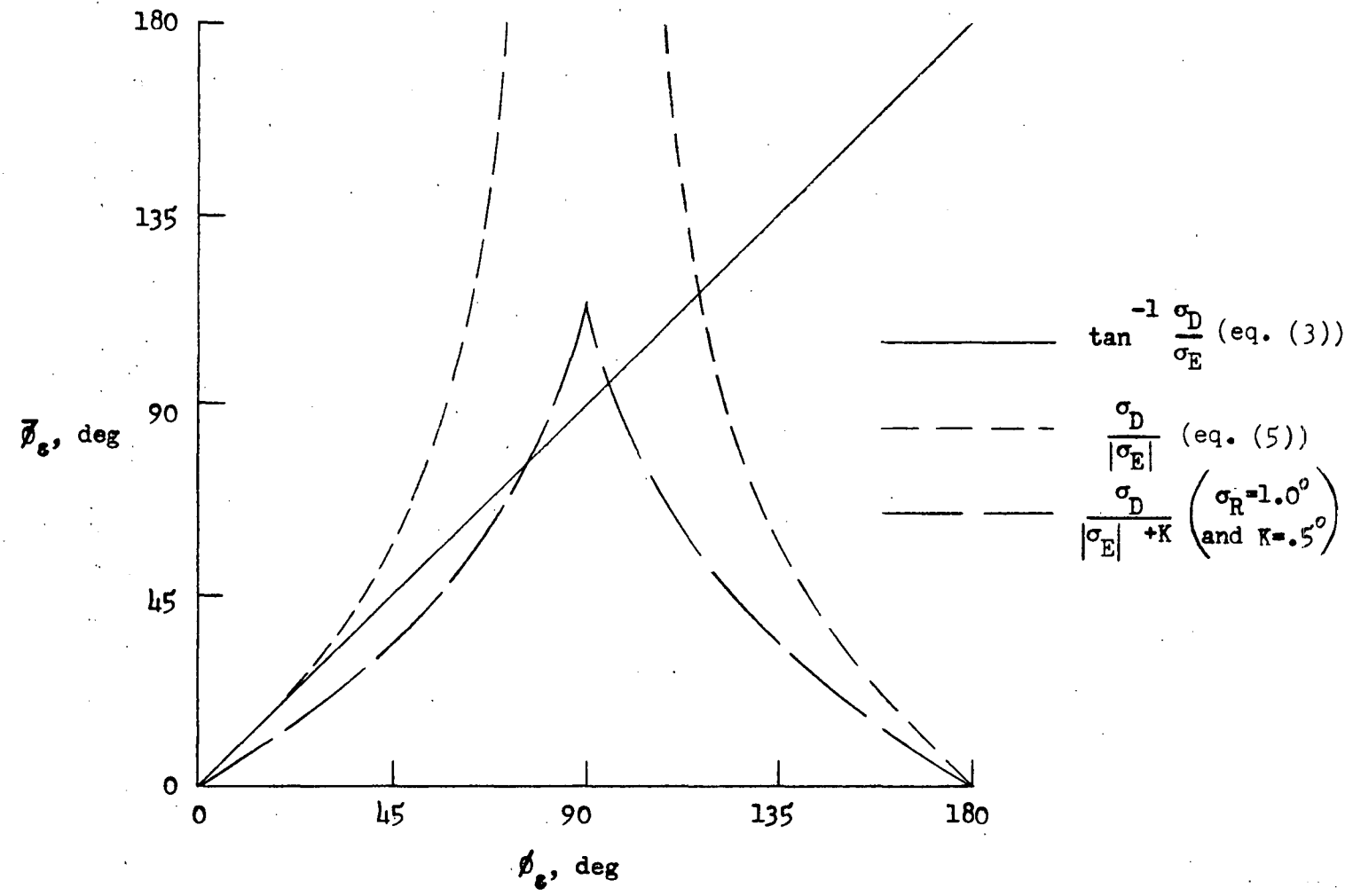

Figure 20.- Variation of computed bank-angle error with actual bank-angle error. No gravity considerations.



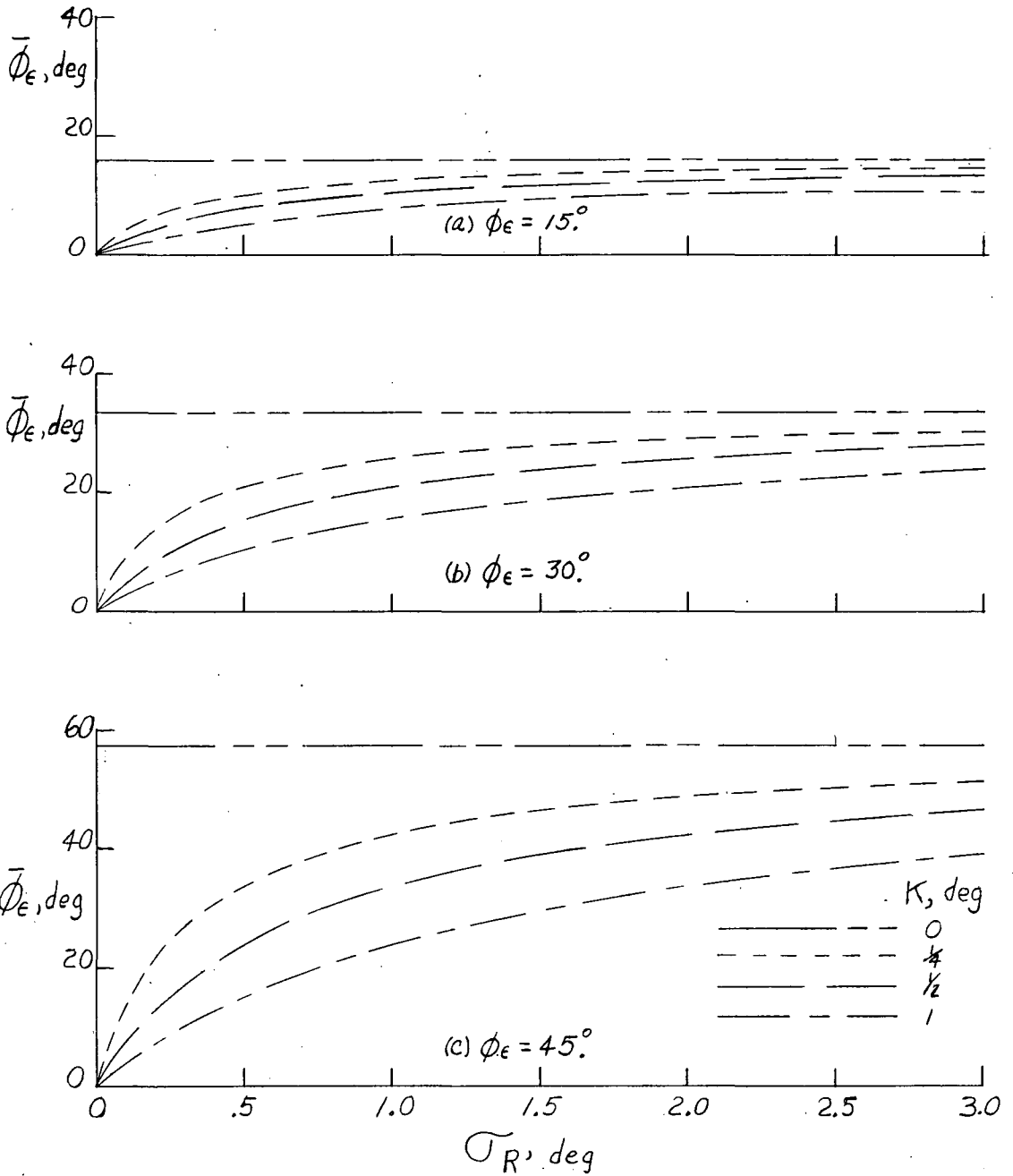
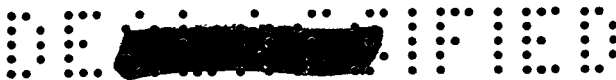

Figure 21.- Effect of K and σ_R upon bank-angle-error computation for three bank-angle errors. No gravity considerations.





———— $\phi_{\epsilon, g} = \tan^{-1} \frac{\sigma_D - \frac{2}{3} \sin \phi}{\sigma_E + \frac{2}{3} \cos \phi}$ (eq. (2))

----- $\phi_{\epsilon, g} = \frac{\sigma_D - \frac{2}{3} \phi}{|\sigma_E + \frac{2}{3}|}$ (eq. (4))

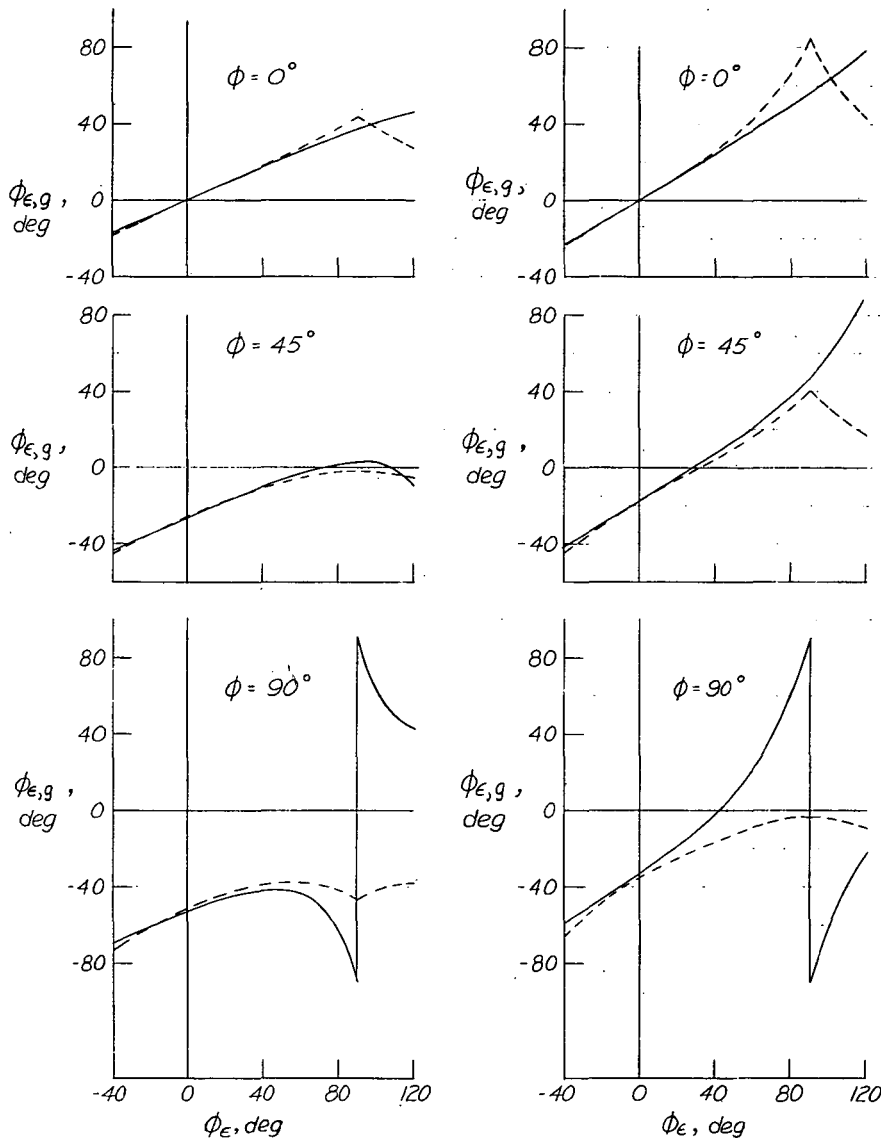

(a) $\sigma_R = 0.5^\circ$.

(b) $\sigma_R = 1.0^\circ$.

Figure 22.- Comparison of two bank-angle-error computations for various angles of ϕ_ϵ at three values of interceptor bank angle. $K = \frac{2}{3}$.



CONFIDENTIAL

CONFIDENTIAL