

# RESEARCH MEMORANDUM

FLIGHT DETERMINATION OF THE LATERAL HANDLING QUALITIES  
OF THE BELL X-5 RESEARCH AIRPLANE AT 58.7° SWEEPBACK

By Thomas W. Finch and Joseph A. Walker

High-Speed Flight Station  
Edwards, Calif.

**NATIONAL ADVISORY COMMITTEE  
FOR AERONAUTICS  
WASHINGTON**

May 31, 1956  
Declassified October 28, 1960

STATE OF CALIFORNIA

OFFICE OF THE ATTORNEY GENERAL

IN RE: [Illegible Name]  
[Illegible Address]  
[Illegible City, State, Zip]

## NATIONAL ADVISORY COMMITTEE FOR AERONAUTICS

## RESEARCH MEMORANDUM

FLIGHT DETERMINATION OF THE LATERAL HANDLING QUALITIES  
OF THE BELL X-5 RESEARCH AIRPLANE AT  $58.7^{\circ}$  SWEEPBACK

By Thomas W. Finch and Joseph A. Walker

## SUMMARY

The Bell X-5 variable-sweep research airplane has been tested primarily at  $58.7^{\circ}$  sweepback to determine the characteristics at transonic speeds of a fighter-type airplane having extreme sweepback. Some of the dynamic and static lateral stability characteristics have been discussed previously. This paper will summarize the overall lateral stability and control characteristics up to a Mach number of 0.97 at 40,000 feet and to slightly lower Mach numbers at altitudes of 25,000 and 15,000 feet.

The dynamic characteristics were influenced by aerodynamic and engine gyroscopic coupling. The short-period lateral oscillations were moderately well damped up to a Mach number of 0.80, but were only tolerable at higher Mach numbers because of the influence of nonlinear damping. However, the damping was generally unsatisfactory over most of the Mach number range when compared to the Military Specification.

The apparent directional stability was positive and about constant for all test altitudes up to a Mach number of 0.85 and increased appreciably at higher Mach numbers. The apparent effective dihedral was positive and had a high value, increasing rapidly at higher Mach numbers. The lateral-force coefficient per degree of sideslip was about constant for all altitudes to a Mach number of 0.94 and increased rapidly with further increase in Mach number at 40,000 feet. There was little change in pitching moment caused by sideslip at any altitude for the limited range of sideslip angles tested. Changes in dynamic pressure had little effect on most of the static stability characteristics.

The rolling characteristics were affected considerably by the adverse dihedral effects at some flight conditions. The aileron effectiveness was low at all altitudes and varied little with Mach number. The airplane failed to meet the Military Specification requirement for rolling velocity and the requirement of 1 second to bank to  $100^{\circ}$ .

Directional divergence occurred at high lifts and resulted in sideslip angles in excess of  $25^\circ$  at low Mach numbers. Aileron overbalance usually followed the divergence and caused the stick to jerk from side to side unless restrained.

Abrupt wing dropping occurred near a Mach number of 0.91 at 40,000 feet. Wing heaviness was evident at higher Mach numbers and at higher dynamic pressures. Single-degree-of-freedom flutter with a frequency of 30 cycles per second occurred on the rudder at low supersonic Mach numbers at high altitude.

The pilot considered the X-5 to have the least desirable lateral stability and control characteristics of a number of straight-wing, swept-wing, delta-wing, and semitailless configurations.

### INTRODUCTION

The Bell X-5 research airplane was procured for the National Advisory Committee for Aeronautics by the U. S. Air Force to investigate the characteristics of a variable-sweep fighter-type airplane at transonic speeds. The tests conducted at the NACA High-Speed Flight Station at Edwards, Calif. have been performed primarily at  $58.7^\circ$  sweepback.

The static lateral stability characteristics measured in sideslip maneuvers at 40,000 feet were discussed in reference 1 and the problems of directional divergence and aileron overbalance were introduced in references 2 and 3. The dynamic lateral stability characteristics were discussed in reference 4. This paper presents the lateral handling qualities for Mach numbers up to 0.97 at 40,000 feet and to slightly lower Mach numbers at altitudes of 25,000 and 15,000 feet.

### SYMBOLS

$a_n$	normal acceleration, g units
$b$	wing span, ft
$C_{l/2}$	cycles to damp to half amplitude of lateral oscillation
$C_{l\beta}$	variation of rolling-moment coefficient with angle of sideslip, $\frac{dC_l}{d\beta}$ , per radian

$C_{N_A}$	airplane normal-force coefficient
$C_{n_\beta}$	variation of yawing-moment coefficient with angle of sideslip, $\frac{dC_n}{d\beta}$ , per deg
$C_{n_{\delta_r}}$	variation of yawing-moment coefficient with rudder deflection, $\frac{dC_n}{d\delta_r}$ , per deg
$C_{Y_\beta}$	variation of lateral-force coefficient with angle of sideslip, $\frac{dC_Y}{d\beta}$ , per deg
$c$	wing chord, ft
$\frac{dF_a}{d\beta}$	variation of aileron stick force with sideslip angle, lb/deg
$\frac{dF_r}{d\beta}$	variation of pedal force with sideslip angle, lb/deg
$\frac{d\delta_{at}}{d\beta}$	apparent effective dihedral parameter
$\frac{d\delta_r}{d\beta}$	apparent directional stability parameter
$\frac{d\phi}{d\beta}$	apparent lateral force parameter
$F$	control force, lb
$g$	acceleration due to gravity, ft/sec <sup>2</sup>
$h_p$	pressure altitude, ft
$i_t$	stabilizer setting with respect to fuselage center line, positive when leading edge of stabilizer is up, deg
$M$	Mach number
$P$	period of lateral oscillation, sec

$pb/2V$	wing-tip helix angle, radians
$p$	rolling velocity, radians/sec
$q$	pitching velocity, radians/sec
$r$	yawing velocity, radians/sec
$T_{p_{max}}$	time for rolling velocity to reach maximum value, sec
$T_{1/2}$	time to damp to half amplitude of lateral oscillation, sec
$T_{100^\circ}$	time to bank to $100^\circ$ , sec
$t$	time, sec
$V$	velocity, ft/sec
$V_c$	calibrated airspeed, mph
$v_e$	equivalent side velocity, ft/sec
$\alpha$	angle of attack, deg
$\beta$	angle of sideslip, deg
$\delta$	control deflection, deg
$\phi$	bank angle, deg

## Subscripts:

$a_L$	left aileron
$a_R$	right aileron
$a_t$	total aileron
$e$	elevator
$r$	rudder
$max$	maximum value

## DESCRIPTION OF THE AIRPLANE

The Bell X-5 is a transonic research airplane incorporating a wing which has sweepback variable in flight between  $20^{\circ}$  and  $58.7^{\circ}$ . A photograph of the airplane with the wing at the  $58.7^{\circ}$  swept position is given in figure 1 and a three-view drawing is presented in figure 2. The physical characteristics of the airplane are given in table I. The lateral and directional control system is unboosted and is composed of ailerons with a 45-percent sealed internal balance and a rudder with a partial span 23.1-percent overhang balance. The friction in the aileron- and rudder-control systems is on the order of  $\pm 3$  pounds.

## INSTRUMENTATION

The following quantities pertinent to this investigation were recorded on NACA internal recording instruments synchronized by a common timer:

- Airspeed and altitude
- Normal and transverse acceleration
- Angles of attack and sideslip
- Aileron, rudder, and elevator deflections
- Aileron and elevator stick force
- Rudder pedal force
- Rolling, yawing, and pitching velocity
- Wing sweep angle

An NACA cavity-type total-pressure head was mounted on a nose boom as shown in figure 2. The position error of the head was calibrated in flight and the accuracy of Mach number measurement from the airspeed calibration is within  $\pm 0.01$ . The angles of attack and sideslip were measured by vanes located on the same boom.

## TESTS

The tests were conducted in the clean configuration with the center-of-gravity position at about 45 percent of the mean aerodynamic chord up to Mach numbers near  $M = 0.97$  at 40,000 feet and to slightly lower Mach numbers at altitudes of 25,000 and 15,000 feet.

The rudder-pulse data were obtained near trim lifts for 1 g flight up to a Mach number of 0.96 at altitudes of 40,000 and 25,000 feet.

The characteristics in sideslips were measured during increasing and decreasing sideslip angles up to Mach numbers of 0.97, 0.95, and 0.92 at altitudes of 40,000 (ref. 1), 25,000, and 15,000 feet, respectively. Rudder-fixed aileron rolls from level flight were also performed at the same altitudes and similar Mach numbers with half-to-full aileron stick deflections. No full deflection rolls were made at 15,000 feet. A chain stop was used to enable the pilot to hold constant aileron input.

## RESULTS AND DISCUSSION

### Dynamic Lateral Stability

To present a complete discussion of the lateral handling qualities of the X-5 airplane a summary of the dynamic characteristics, previously reported in reference 4, is repeated in this paper.

A typical time history of the short-period lateral oscillation resulting from an abrupt rudder pulse is shown in figure 3. A longitudinal oscillation is also produced because of aerodynamic and engine gyroscopic coupling and some residual oscillation is evident even with negligible control motions. At low Mach numbers the oscillation is moderately well damped, but at Mach numbers above  $M = 0.80$  the decay of the oscillation is nonlinear and the damping decreases with decreasing amplitude, resulting in nearly zero damping at small amplitudes.

For convenience the damping has been measured for two amplitudes,  $\beta > 2^\circ$  and  $\beta < 2^\circ$ . The period, time to damp to half amplitude, and cycles to damp to half amplitude are presented in figure 4. The period gradually decreases from about 2.7 to 1.4 seconds over a Mach number range of about 0.52 to 0.96. There is no appreciable difference in the Mach number variation of the value of  $T_{1/2}$  measured for the large-amplitude portions of the oscillation below  $M = 0.80$ , but at higher Mach numbers there is a noticeable difference in damping between oscillations produced by left and right rudder inputs. This difference may be attributed to gyroscopic and aerodynamic coupling (ref. 4) and continues to the test limit Mach number, with power damping resulting from a left input. At Mach numbers near  $M = 0.83$  the small-amplitude portions of the oscillation are poorly damped, resulting in a residual oscillation of low but nevertheless objectionable amplitude over a Mach number range from about 0.86 to 0.88 with the value of  $T_{1/2}$  almost double that for the large amplitude. Above about  $M = 0.93$  the damping appears to be largely unaffected by amplitude.

The amplitude of the residual undamped oscillation with stick held manually (data not shown) follows the same general Mach number variation



as followed by the small-amplitude damping characteristics (ref. 4). The residual oscillation amplitude reached a maximum magnitude in sideslip of  $0.3^\circ$  with the stick restrained by a mechanical stop as compared with a maximum amplitude of  $2.5^\circ$  with the stick restrained manually. Consequently, it appears that minor aileron movements are the primary cause of the residual oscillation, although the pilot felt that any control motion, thrust change, or turbulent air excited the oscillation.

The effect of altitude on  $P$ ,  $T_{1/2}$ , and  $C_{1/2}$  is also shown in figure 4 for a Mach number range from about 0.52 to 0.94. At an altitude of 25,000 feet the Mach number variation of the period is similar to the variation at 40,000 feet, but the magnitude is reduced as would be expected for the change in dynamic pressure. The cycles to damp to half amplitude follow the same general trend as at 40,000 feet, and the degree of damping is about the same, except the nonlinear effects are not present.

In figure 5 a comparison is made of the X-5 flight results with the Military Specification for dynamic lateral stability (ref. 5). The requirements relate the reciprocal of cycles to damp to half amplitude to the ratio of roll angle to side velocity  $\frac{|\phi|}{|v_e|}$ .

Representative data for the Mach number range are shown in figure 5 and indicate unsatisfactory stability over most of the Mach number range. Most of the marginal points are indicative of the large-amplitude portion of the oscillation, whereas the small-amplitude data are found to be more unsatisfactory. The pilot felt the dynamic characteristics were tolerable except in the Mach number region of nonlinear damping in which the large ratio of roll to sideslip with low damping made the characteristics intolerable.

### Static Lateral Stability

Typical examples of the results of the static lateral stability characteristics at 40,000 feet (ref. 1) are presented in figure 6 as functions of sideslip angle. Aileron, rudder, and elevator positions and forces are presented as a function of sideslip angles. Angle of bank as obtained from the transverse acceleration is also shown. The data scatter results from the almost continuous oscillatory motion during the sideslip maneuvers.

The variations of the slopes  $d\phi/d\beta$  the apparent lateral force parameter,  $d\delta_r/d\beta$  the apparent directional stability parameter, and  $d\delta_{at}/d\beta$  the apparent effective dihedral parameter for altitudes of 40,000, 25,000, and 15,000 feet are presented as functions of Mach number

and calibrated airspeed in figure 7. The apparent directional stability parameter is positive and gradually increases from a constant value of about  $d\delta_r/d\beta = 1.6$  at Mach numbers near 0.90, 0.86, and 0.80 to values on the order of 2.6, 3.1, and 4.0 at Mach numbers of 0.97, 0.95, and 0.92 for altitudes of 40,000, 25,000, and 15,000 feet, respectively. These increases are caused primarily by Mach number effects since, as indicated in figure 7 by the variation of  $d\delta_r/d\beta$  with calibrated airspeed, there is no appreciable effect that is consistent with change in dynamic pressure. Unpublished wind-tunnel results show little change in the directional stability parameter  $C_{n\beta}$  with Mach number in the lift range covered by these tests. This change can be determined by the Mach number variation of the period, therefore it is indicated that the increase in  $d\delta_r/d\beta$  is primarily caused by a decrease in  $C_{n\delta_r}$ .

The apparent effective dihedral parameter  $d\delta_{at}/d\beta$  is high throughout the Mach number range for all test altitudes with the value of 6.7 below  $M = 0.75$  increasing to a value of 13.5 at  $M = 0.97$  for an altitude of 40,000 feet. The Mach number variation at the lower test altitudes is generally the same, but the magnitudes of  $d\delta_{at}/d\beta$  are somewhat lower. This decrease in magnitude would be expected, since the lift coefficient is reduced at the lower altitudes and the dihedral parameter  $C_{l\beta}$  will be correspondingly reduced.

The lateral force is stable with right bank required for right sideslip. The parameter  $d\phi/d\beta$  at 40,000 feet gradually increases with Mach number, approximately doubling from  $M = 0.62$  to  $M = 0.93$ , and rapidly increases to  $M = 0.97$ , the limit of the tests. The Mach number variations at the lower test altitudes are generally similar, with the magnitude of  $d\phi/d\beta$  increasing on the order of 2.5 to 3.0 times at 15,000 feet for a given Mach number. The increased values at the lower test altitudes are approximately those expected with  $d\phi/d\beta$  inversely proportional to lift coefficient as indicated by the variations of  $d\phi/d\beta$  with calibrated airspeed which gradually increases with increasing dynamic pressure. In general, the critical Mach number for all lateral stability parameters decreases slightly with decreasing altitude.

The control forces required to perform sideslips are presented in figure 8, in the form of  $dF_a/d\beta$  and  $dF_r/d\beta$ , as a function of Mach number and calibrated airspeed. Generally, the variations with Mach number are similar to the variations of  $d\delta_{at}/d\beta$  and  $d\delta_r/d\beta$  shown in figure 7. As would be expected from completely unboosted control systems,  $dF_a/d\beta$  and  $dF_r/d\beta$  show an increase with increasing dynamic pressure and the control forces are high particularly above the critical Mach number. The variations with calibrated airspeed indicate very little consistent effect due to dynamic pressure.

There is essentially no change in pitching moment caused by sideslip at all test altitudes as indicated by the almost constant value of elevator position during the sideslips in the limited test range.

The lateral-force parameter  $C_{Y\beta}$  was determined from the variation of the lateral-force coefficient  $(-C_Y = C_{N_A} \sin \phi)$  with sideslip angle and is presented as a variation with Mach number in figure 9. The variation of  $C_{N_A}$  with Mach number is also shown in this figure. The value of  $C_{Y\beta}$  remains about constant near -0.0085 for all test altitudes up to a Mach number of about 0.94 where the value at an altitude near 40,000 feet increases to about -0.014.

### Lateral Control

Time histories of representative full-stick deflection aileron rolls and bank angles developed during the rolls are presented in figure 10 for an altitude of 40,000 feet. The pilot found it difficult to repeat maneuvers at the same conditions since small changes in sideslip possibly caused by engine gyroscopic coupling or control motions, or both, have a large effect on the aileron effectiveness. These changes in  $\beta$  produce large increments in rolling moment because of the excessive dihedral effect. Consequently, the first peak in the rolling velocity was used to determine the aileron effectiveness since there was usually no steady-state rolling velocity.

The variation of the aileron effectiveness parameter  $\frac{pb}{2V} / \delta_{at}$ , maximum rolling velocity, and maximum wing-tip helix angle  $pb/2V$  with Mach number is presented in figure 11. The effectiveness is very low  $(\frac{pb}{2V} / \delta_{at} = 0.0005 \text{ at } M = 0.71)$  at 40,000 feet and increases only slightly with Mach number. The effectiveness is still low at an altitude of 25,000 feet and an altitude of 15,000 feet (determined from one-half deflection rolls), but the value of  $\frac{pb}{2V} / \delta_{at}$  is increased to a nearly constant value of 0.001. Because the adverse effects of  $C_{l\beta}$  were considerably decreased at the lower altitudes, it is felt the rolling effectiveness presented for 25,000 feet is more nearly representative of the X-5 airplane at least for this altitude and for lower altitudes.

The maximum measured values of rolling velocity at 40,000 feet were on the order of 0.9 radian per second at  $M = 0.71$ , increasing to a value of 2.0 radians per second near  $M = 0.96$ . Although the peak rolling rates measured in some right rolls (fig. 10) were near 2.0 radians per second at Mach numbers less than  $M = 0.9$ , because of the high dihedral effect

or adverse control motions, it is felt the variation of maximum rolling velocity with Mach number mentioned previously is representative of 40,000 feet. At 25,000 feet the value was increased on the order of 1 radian per second at all Mach numbers.

The maximum values of  $pb/2V$  were generally less than 0.02 at 40,000 feet and less than 0.03 at 25,000 feet. The airplane is not required to meet the Military Specification requirement of  $pb/2V = 0.09$  (ref. 5) since the requirement of  $220^\circ$  per second is lower; however, the X-5 fails to meet this requirement by at least an increment of  $pb/2V$  of about 0.015 ( $80^\circ$  per sec) at higher Mach numbers.

The time required to bank to  $100^\circ$ ,  $T_{100^\circ}$ , for full-stick deflection aileron rolls as determined from time histories of bank angle is presented in figure 12. At 40,000 feet the time to bank to  $100^\circ$  decreases with increasing Mach number to a value of about 1.5 seconds at  $M = 0.95$ . At 25,000 feet the value of  $T_{100^\circ}$  has decreased so that at Mach numbers near 0.93 the value nearly meets the requirement of 1 second to bank to  $100^\circ$  specified in reference 5. A brief inspection of the variation with Mach number of the time to bank to maximum rolling velocity  $T_{p_{max}}$  in figure 12 indicates considerable scatter. The only obvious trend is that the value of  $T_{p_{max}}$  tends to decrease with increasing Mach number and decreasing altitude, and the values measured in right rolls are somewhat lower than those measured in left rolls.

### Roll Coupling

During the flight investigation of several current airplanes, undesirable large roll coupling effects have been encountered in abrupt aileron rolls and were reported in references 6 and 7. By using the analytical methods given in reference 8 in modified form it was shown in reference 9 that, when the average roll velocity in  $360^\circ$  rolls approaches the lower resonant frequency, undesirably large changes in angle of sideslip and angle of attack might be expected.

The approximate flight test envelope of the X-5 airplane is shown in figure 13 together with lines of constant lower resonant frequency (pitch). It is evident, even in comparing the frequency required for resonance with the maximum available rolling velocity (fig. 11), that the aileron power is far too low in the Mach number range investigated to expect large roll coupling effects.

## Lateral Problems at High Lift

As reported in reference 2, the pitching characteristics of the airplane above the longitudinal stability decay or pitch-up boundary are aggravated by the occurrence of directional divergence and aileron overbalance. Figure 14 presents time histories of typical accelerated maneuvers performed at 40,000 feet during which both these lateral deficiencies occur. At lower Mach numbers the airplane has diverged in sideslip to angles in excess of  $25^\circ$ , resulting in a spin. Although the airplane would often snap-roll as it diverged, it normally responded to the elevator control as the pilot recovered. The divergence became less severe at higher Mach numbers with a resulting oscillatory motion in sideslip on the order of  $\pm 3^\circ$  near  $M = 0.92$ . The pilot reported minor oscillations caused by divergence up to  $M = 1.0$ . The onset of directional divergence in terms of  $C_{NA}$  and  $\alpha$  (fig. 14) is presented in figures 15 and 16 with relation to the longitudinal stability decay or pitch-up boundary presented in reference 2. It may be noted that the divergence may occur at any normal-force coefficient or angle of attack after pitch-up to maximum lift, but generally occurs on the order of 0.10 to 0.15 in  $C_{NA}$  or about  $2^\circ$  to  $3^\circ$  in angle of attack above the pitch-up boundary over a Mach number range from about 0.65 to 0.92. The results of reference 3 and unpublished vertical-tail-loads data show that the vertical tail does not unload during the divergence. This condition indicates the rapid change in the wing-fuselage contribution to directional stability is the main cause of the divergence. The divergence was predicted in reference 10 and unpublished wind-tunnel results indicated the divergence could be expected about 0.10 in  $C_{NA}$  above the pitch-up boundary.

The problem of aileron overbalance occurred less frequently but was no less disconcerting to the pilot because the stick would jerk from side to side unless restrained. When the stick was restrained laterally with a strap during some accelerated maneuvers, the pilot obviously was unaware of this problem. Although it was not easily identified in many instances, the occurrence of aileron overbalance was defined by the reversal of aileron stick force with respect to total aileron deflection as indicated in figure 14. The onset of aileron overbalance in terms of  $C_{NA}$  and  $\alpha$  is presented in figures 17 and 18, respectively, with relation to the pitch-up boundary. The aileron overbalance may similarly occur at any normal-force coefficient or angle of attack after pitch-up to maximum lift, but generally seems to occur after the onset of directional divergence.

### Wing Dropping

The abrupt change in lateral trim or wing-dropping tendencies noted on a number of other airplanes at transonic Mach numbers is also a characteristic of the X-5. The wing drops rather abruptly, generally to the left, in the Mach number range from about 0.90 to 0.92 at 40,000 feet and at slightly lower Mach numbers at lower test altitudes. The pilot reported this occurrence was difficult to correct without overcontrolling, and he felt the wing dropping was caused by a combined directional and lateral trim change with the directional change predominating. The wing-dropping tendency stopped after a change in Mach number of 0.02; however, the pilot reported left-wing heaviness at higher Mach numbers and at higher dynamic pressures.

An example of wing dropping which occurred at 40,000 feet is presented as a time history in figure 19. The usual unsteady behavior is apparent with the wing dropping to a bank angle of about  $13^\circ$  at  $M = 0.91$ . The pilot used about  $5^\circ$  of aileron to stop wing dropping in this case, but normally, the pilot would correct the wing dropping with rudder deflection.

### Rudder Oscillation at Supersonic Mach Numbers

Another control problem encountered at low supersonic Mach numbers was single-degree-of-freedom flutter of the rudder. A time history of quantities measured during a shallow dive to 30,000 feet is presented in figure 20. A constant 30-cps oscillation occurred on the rudder and vertical fin as the Mach number decreased from 1.06 to 1.00 during recovery from the dive. The actual values of the rudder deflection and pedal force may be as high as  $\pm 4^\circ$  and  $\pm 20$  pounds, respectively, since the measured values were on the order of only 25 to 30 percent of the actual values because of the frequency-response characteristics of the recording elements.

With the rudder-control system made as rigid as possible, a dive was repeated and an intermittent 30-cps oscillation was recorded in about the same Mach number range. The pilot reported he could feel the oscillation through the rudder pedals and that rudder deflection from neutral apparently had no effect on the oscillation.

### Pilots' Impressions

The X-5 airplane at  $58.7^\circ$  sweepback is considered to have the least desirable lateral stability and control characteristics of any of the airplanes tested, including straight-wing, swept-wing, semitailless, and delta-wing configurations. One pilot, while checking out in the X-5 airplane, discontinued a speed run at  $M = 0.85$  and an altitude of 35,000 feet because he strongly doubted his ability to keep the airplane right side up.

The outstanding deficiency of the X-5 airplane is the lateral-directional oscillation or "Dutch roll" caused by high positive dihedral effect. This oscillation is annoying but tolerable for research flying over the entire speed range at 40,000 feet, except over the range of  $M = 0.86$  to  $M = 0.88$  where the residual, small amplitude, virtually undamped oscillation is most noticeable. The dihedral effect decreases with a decrease of altitude but never reaches a satisfactory value. The airplane exhibits positive lateral stability during sideslip maneuvers and requires large aileron deflections for small rudder deflections; however, it is impossible to maintain a steady sideslip without rolling oscillations. Normal turning maneuvers tend to be jerky with abrupt increases and decreases of bank angle, apparently caused by small yawing motions and angle-of-attack changes. In straight and level flight, lateral-directional oscillations can be initiated by control motions, power changes, or turbulent air.

The aileron effectiveness is low at all Mach numbers and, except for the adverse dihedral effects in some conditions, the rolling characteristics are normal with rolling velocity proportional to aileron deflection and increase as Mach number increases. The rolling characteristics improve with decrease of altitude, but maximum rolling velocity is limited because of the excessive force necessary to obtain large aileron deflections. Near the lg stall there is little or no lateral control and nearly zero aileron stick force.

#### CONCLUSIONS

From the flight investigation of the Bell X-5 research airplane at  $58.7^\circ$  sweepback at altitudes of 40,000, 25,000, and 15,000 feet it may be concluded that:

1. The dynamic characteristics were influenced by both aerodynamic and engine gyroscopic coupling. The short-period lateral oscillation was moderately well damped up to a Mach number of 0.80, but at higher Mach numbers the damping was only tolerable because of the influence of nonlinear damping. However, in comparison with the Military Specification, the damping was generally unsatisfactory over most of the Mach number range.

2. The apparent directional stability was positive and nearly constant for all test altitudes up to a Mach number of 0.85 and increased appreciably at higher Mach numbers. The apparent effective dihedral had a high positive value and increased rapidly at higher Mach numbers. The lateral-force coefficient per degree of sideslip was nearly constant for all altitudes to a Mach number of 0.94 and increased rapidly with further increase in Mach number at 40,000 feet. There was little change in

pitching moment caused by sideslip at any altitude for the limited range of sideslip angles tested. Changes in dynamic pressure had little effect on most of the static stability characteristics.

3. The rolling characteristics were considerably affected by the adverse dihedral effects, particularly at 40,000 feet. The aileron effectiveness was low at all altitudes and varied little with Mach number. There was insufficient aileron power to meet the Military Specification requirement for rolling velocity or the requirement of 1 second to bank to  $100^\circ$ .

4. Directional divergence occurred at high lifts, resulting in sideslip angles in excess of  $25^\circ$  at low Mach numbers. At high Mach numbers the divergence caused only oscillatory motions in sideslip.

5. Aileron overbalance also occurred at high lifts, causing the stick to jerk from side to side when not restrained. The overbalance usually followed the directional divergence.

6. An abrupt wing-dropping tendency was encountered at 40,000 feet over a Mach number range from about 0.90 to 0.92. Wing heaviness also occurred at higher Mach numbers and at higher dynamic pressures.

7. Single-degree-of-freedom flutter with a frequency of 30 cycles per second occurred on the rudder at low supersonic Mach numbers in gradual dives from 40,000 feet. The oscillatory values of rudder deflection and pedal force were on the order of  $\pm 4^\circ$  and  $\pm 20$  pounds, respectively.

8. The pilot considered the X-5 airplane to have the least desirable overall lateral stability and control characteristics of a number of straight-wing, swept-wing, delta-wing, and semitailless configurations.

High-Speed Flight Station,  
National Advisory Committee for Aeronautics,  
Edwards, Calif., March 27, 1956.



## REFERENCES

1. Childs, Joan M.: Flight Measurements of the Stability Characteristics of the Bell X-5 Research Airplane in Sideslips at 59° Sweepback. NACA RM L52K13b, 1953.
2. Finch, Thomas W., and Walker, Joseph A.: Flight Determination of the Static Longitudinal Stability Boundaries of the Bell X-5 Research Airplane With 59° Sweepback. NACA RM L53A09b, 1953.
3. Drake, Hubert M., Robinson, Glenn H., and Kuhl, Albert E.: Loads Experienced in Flights of Two Swept-Wing Research Airplanes in the Angle-of-Attack Range of Reduced Stability. NACA RM L53D16, 1953.
4. Videan, Edward N.: Flight Measurements of the Dynamic Lateral and Longitudinal Stability of the Bell X-5 Research Airplane at 58.7° Sweepback. NACA RM H55H10, 1955.
5. Anon.: Military Specification - Flying Qualities of Piloted Airplanes. MIL-F-8785 (ASG), 1 September 1954.
6. NACA High-Speed Flight Station: Flight Experience With Two High-Speed Airplanes Having Violent Lateral-Longitudinal Coupling in Aileron Rolls. NACA RM H55A13, 1955.
7. Sisk, Thomas R., and Andrews, William H.: Flight Experience With a Delta-Wing Airplane Having Violent Lateral-Longitudinal Coupling in Aileron Rolls. NACA RM H55H03, 1955.
8. Phillips, William H.: Effect of Steady Rolling on Longitudinal and Directional Stability. NACA TN 1627, 1948.
9. Weil, Joseph, and Day, Richard E.: An Analog Study of the Relative Importance of Various Factors Affecting Roll Coupling. NACA RM H56A06, 1956.
10. Kemp, William B., Jr., and Becht, Robert E.: Stability and Control Characteristics at Low Speed of a 1/4-Scale Bell X-5 Airplane Model. Lateral and Directional Stability and Control. NACA RM L50C17a, 1950.

TABLE I  
 PHYSICAL CHARACTERISTICS OF THE BELL X-5 AIRPLANE  
 AT A SWEEP ANGLE OF 58.7°

Airplane:	
Weight, lb:	
Full fuel . . . . .	10,006
Less fuel . . . . .	7,894
Powerplant:	
Axial-flow turbojet engine . . . . .	J35-A-17
Guaranteed rated thrust at 7,800 rpm and static sea-level conditions, lb . . . . .	4,900
Moment of inertia of rotating mass, slug-ft <sup>2</sup> . . . . .	13.1
Center-of-gravity position, percent mean aerodynamic chord:	
Full fuel . . . . .	45.0
Less fuel . . . . .	45.5
Overall height, ft . . . . .	12.2
Overall length, ft . . . . .	33.6
Moments of inertia for 58.7° sweep (clean configuration, full fuel), slug-ft <sup>2</sup> :	
About X-axis . . . . .	5,165
About Y-axis . . . . .	9,495
About Z-axis . . . . .	10,110
Inclination of principal axes, down at the nose, deg . . . . .	1.75
Wing:	
Airfoil section (perpendicular to 38.02 percent chord line):	
Pivot point . . . . .	NACA 64(10)A011
Tip . . . . .	NACA 64(08)A008.28
Sweep angle at 0.25 chord, deg . . . . .	58.7
Area, sq ft . . . . .	183.7
Span, ft . . . . .	20.1
Span between equivalent tips, ft . . . . .	19.3
Aspect ratio . . . . .	2.2
Taper ratio . . . . .	0.411
Mean aerodynamic chord, ft . . . . .	9.95
Location leading edge of mean aerodynamic chord, fuselage station . . . . .	101.2
Incidence root chord, deg . . . . .	0
Dihedral, deg . . . . .	0
Geometric twist, deg . . . . .	0
Wing flaps (split):	
Area, sq ft . . . . .	15.9
Span, parallel to hinge center line, ft . . . . .	6.53
Chord, parallel to line of symmetry at 20° sweepback, in.:	
Root . . . . .	30.8
Tip . . . . .	19.2
Travel, deg . . . . .	60
Slats (leading edge divided):	
Area, sq ft . . . . .	14.6
Span, parallel to leading edge . . . . .	10.3
Chord, perpendicular to leading edge, in.:	
Root . . . . .	11.1
Tip . . . . .	6.6
Travel, percent wing chord:	
Forward . . . . .	10
Down . . . . .	5
Aileron (45-percent internal seal pressure balance):	
Area (each aileron behind hinge line), sq ft . . . . .	3.62
Span parallel to hinge center line, ft . . . . .	5.15
Travel, deg . . . . .	±15
Chord, percent wing chord . . . . .	19.7
Moment-area rearward of hinge line (total), in. <sup>3</sup> . . . . .	4,380

TABLE I.- Concluded

## PHYSICAL CHARACTERISTICS OF THE BELL X-5 AIRPLANE

AT A SWEEP ANGLE OF  $58.7^{\circ}$ 

Horizontal tail:	
Airfoil section (parallel to fuselage center line) . . . . .	NACA 65A006
Area, sq ft . . . . .	31.5
Span, ft . . . . .	9.56
Aspect ratio . . . . .	2.9
Taper ratio . . . . .	0.371
Sweep angle at 0.25 percent chord, deg . . . . .	45
Mean aerodynamic chord, in. . . . .	42.8
Position of 0.25 mean aerodynamic chord, fuselage station . . . . .	355.6
Stabilizer travel, (power actuated), deg:	
Leading edge up . . . . .	4.5
Leading edge down . . . . .	7.5
Elevator (20.8-percent overhang balance, 31.5-percent span):	
Area rearward of hinge line, sq ft . . . . .	6.9
Travel from stabilizer, deg:	
Up . . . . .	25
Down . . . . .	20
Chord, percent horizontal tail chord . . . . .	30
Moment-area rearward of hinge line (total), in. <sup>3</sup> . . . . .	4,200
Vertical tail:	
Airfoil section (parallel to rear fuselage center line) . . . . .	NACA 65A006
Area, (above rear fuselage center line), sq ft . . . . .	25.8
Span, perpendicular to rear fuselage center line, ft . . . . .	6.17
Aspect ratio . . . . .	1.47
Sweep angle of leading edge, deg . . . . .	46.6
Fin:	
Area, sq ft . . . . .	24.8
Rudder (23.1-percent overhang balance, 26.3-percent span):	
Area rearward of hinge line, sq ft . . . . .	4.7
Span, ft . . . . .	4.43
Travel, deg . . . . .	±35
Chord, percent horizontal tail chord . . . . .	22.7
Moment-area rearward of hinge line, in. <sup>3</sup> . . . . .	3,585
Distance from airplane center of gravity to 0.25 mean aerodynamic chord of vertical tail, ft . . . . .	16.5



Figure 1.- Photograph of the Bell X-5 research airplane at  $58.7^\circ$  sweepback. E-813

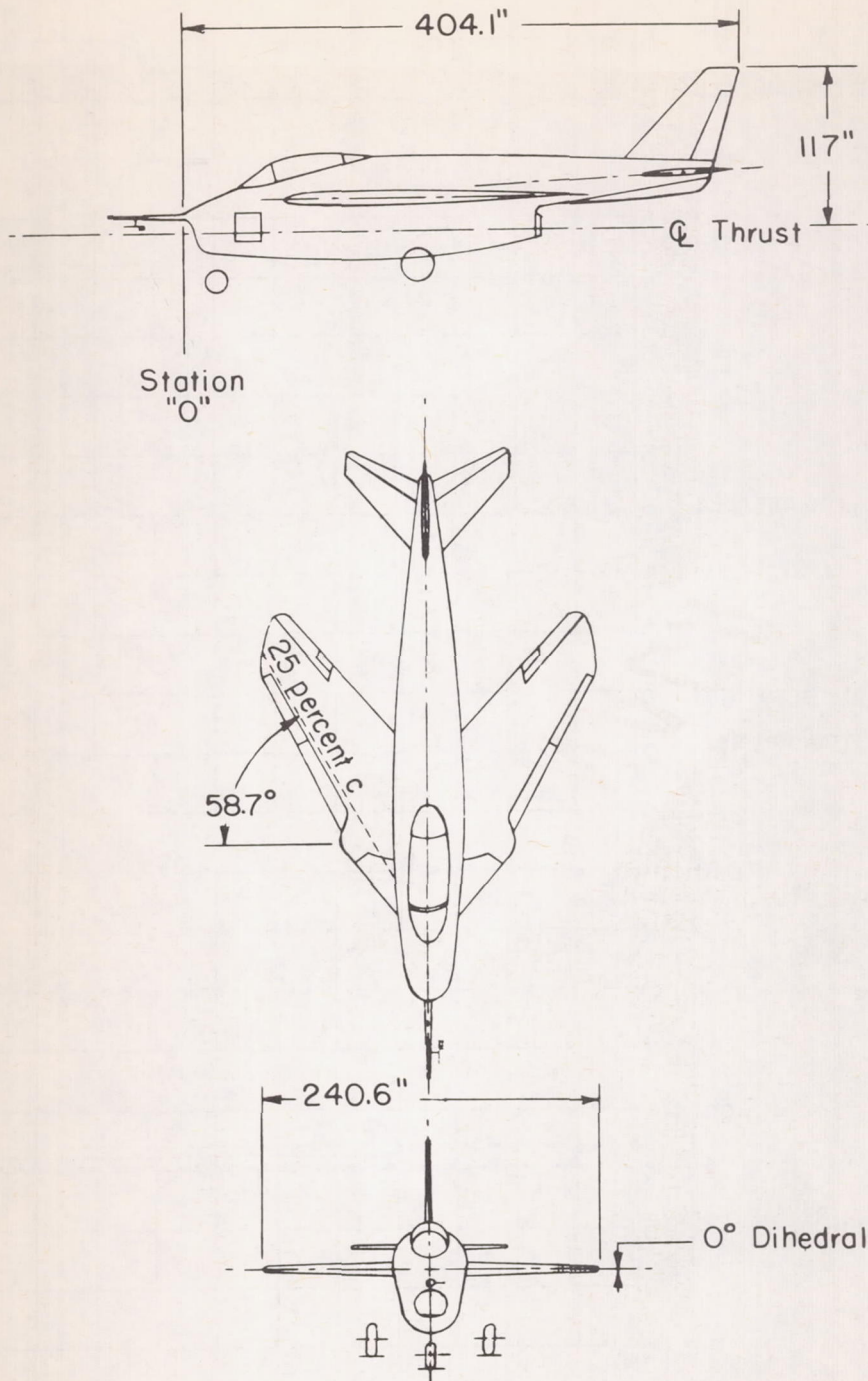

Figure 2.- Three-view drawing of the Bell X-5 research airplane at 58.7° sweepback.

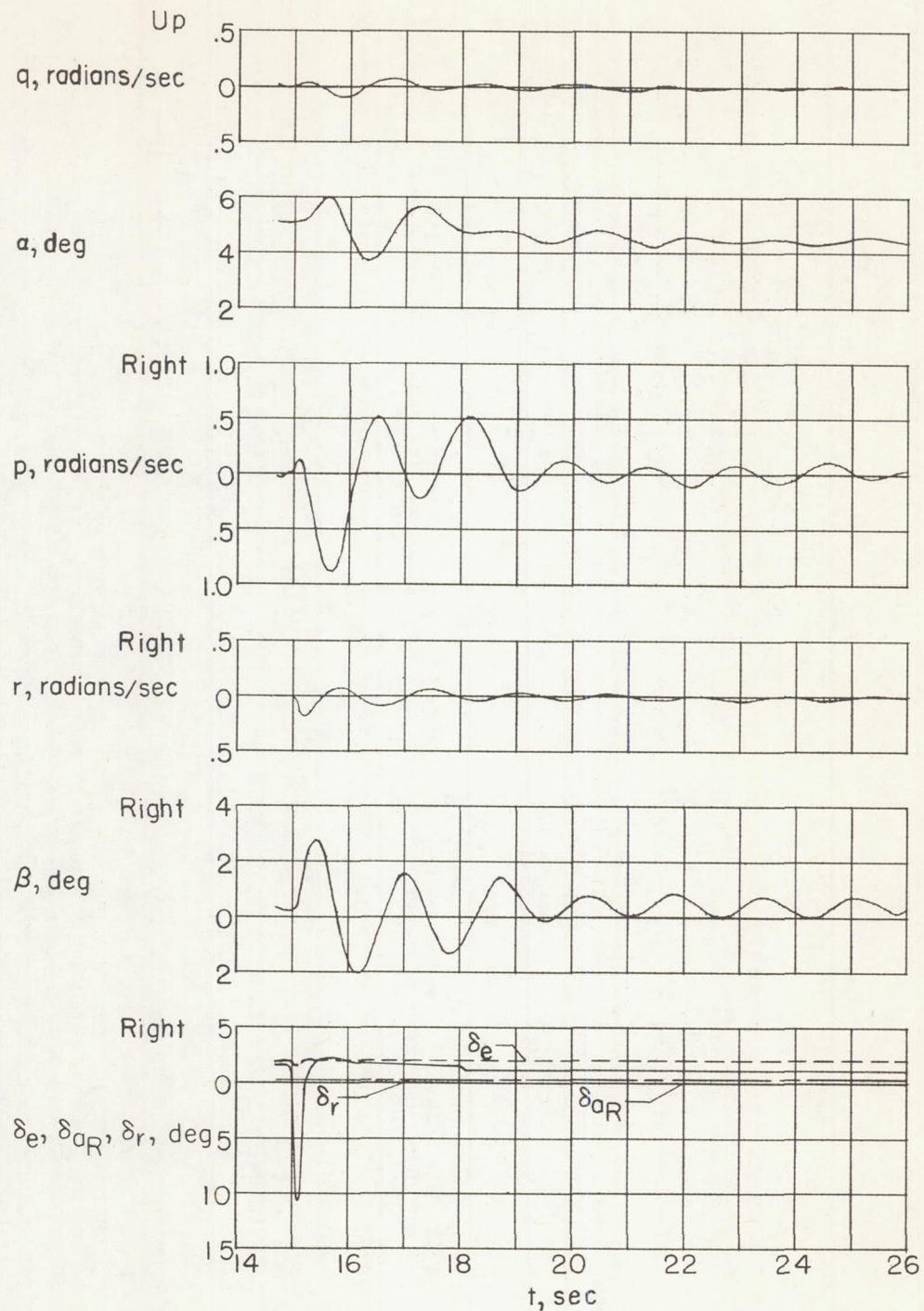

Figure 3.- Time history of lateral oscillation resulting from a rudder pulse at  $M = 0.90$ ;  $h_p = 40,000$  feet.

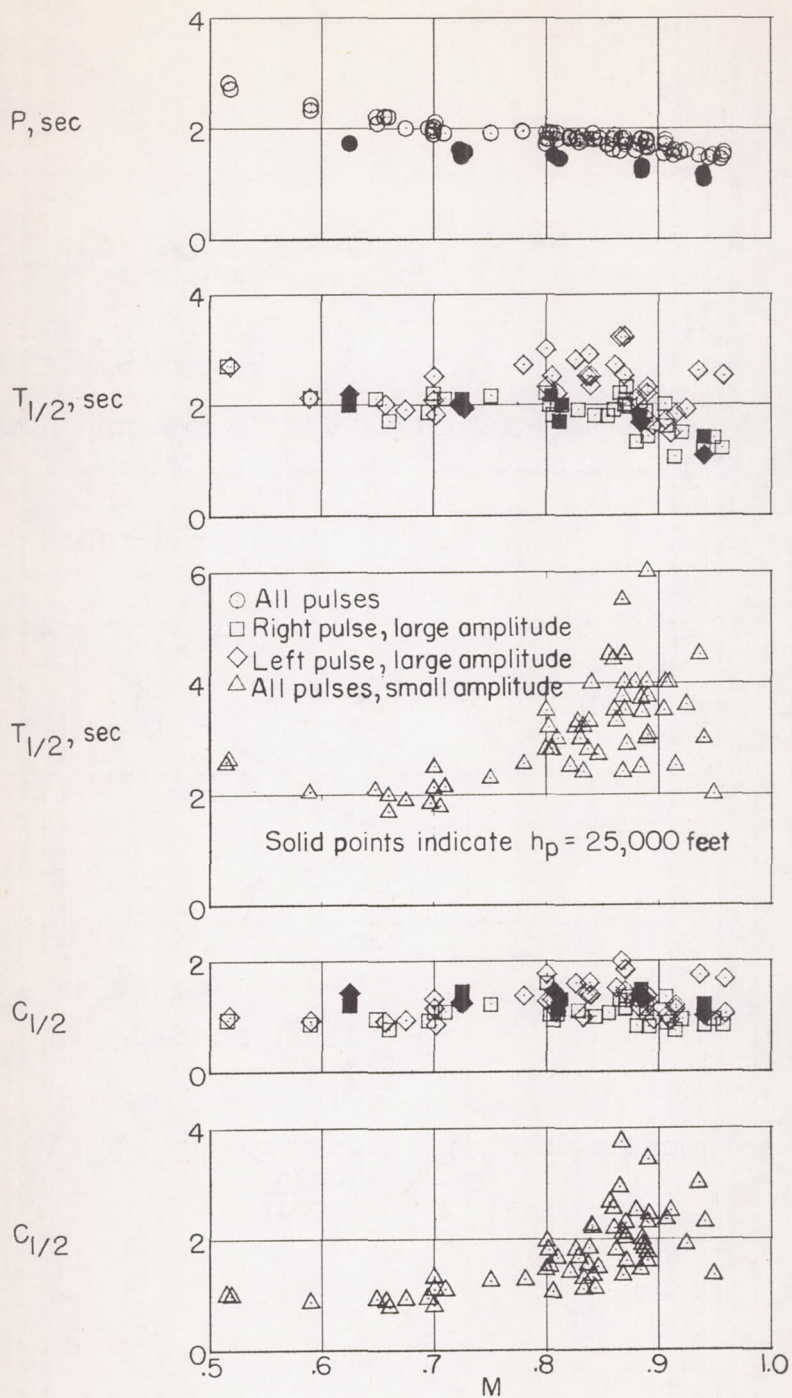

Figure 4.- Period and damping variation of the lateral oscillations.  
 $h_p = 40,000$  feet.

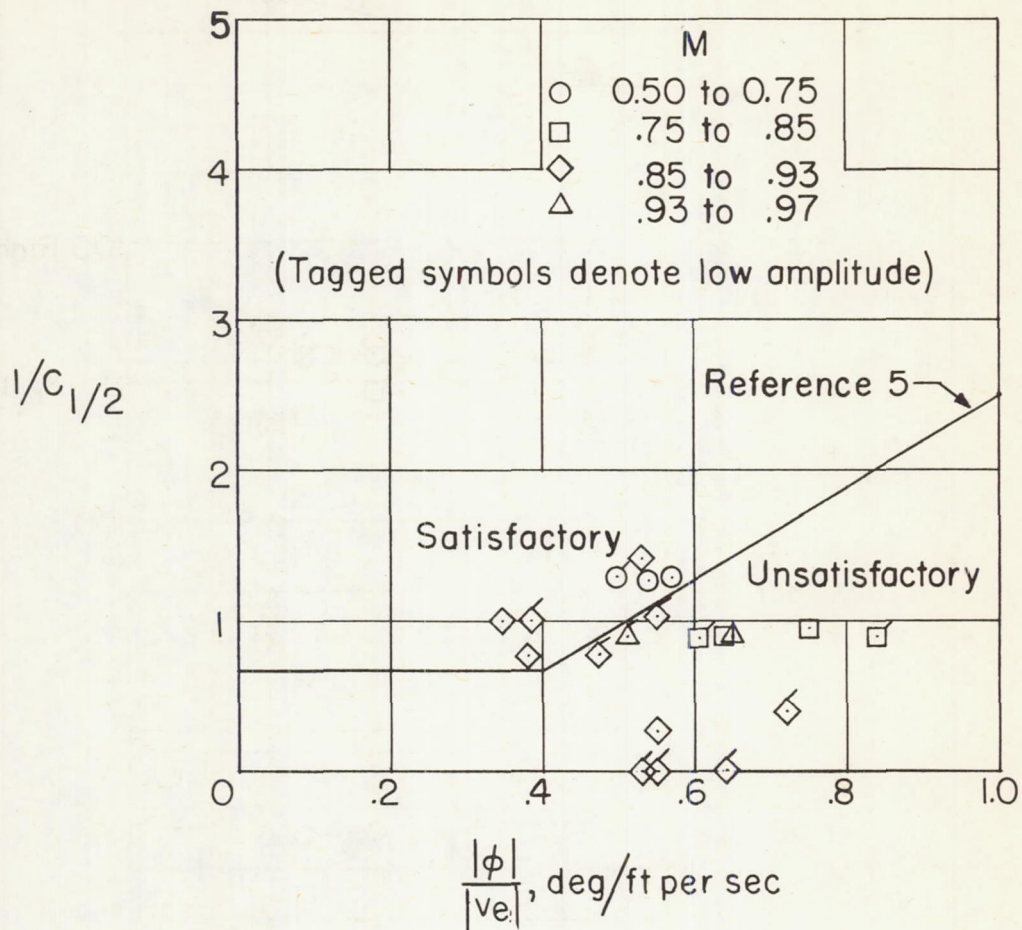
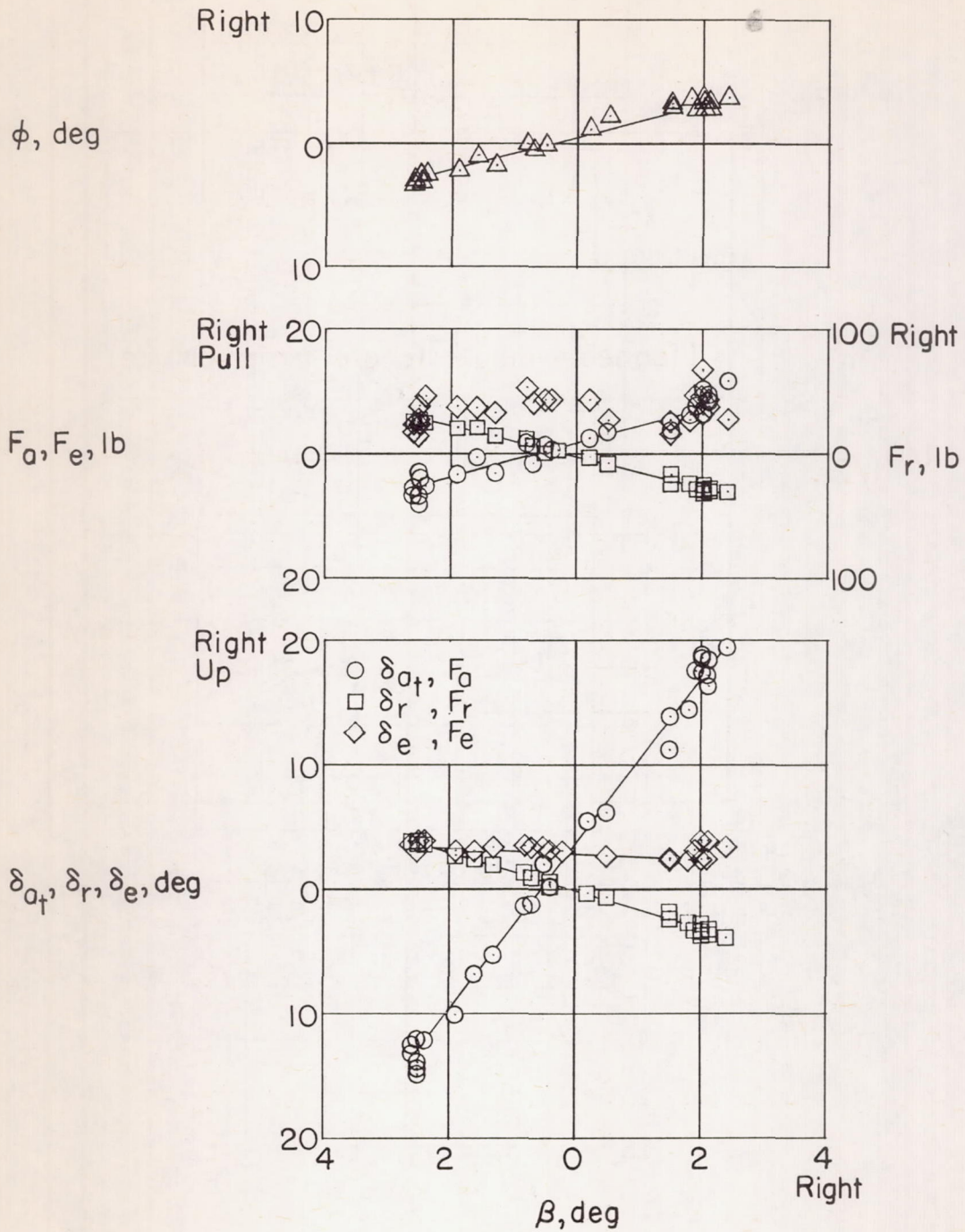

Figure 5.- Comparison of damping characteristics with the Military Specification.





(a)  $M = 0.70$ ;  $h_p = 40,000$  feet.

Figure 6.- Characteristics in sideslip at 40,000 feet.

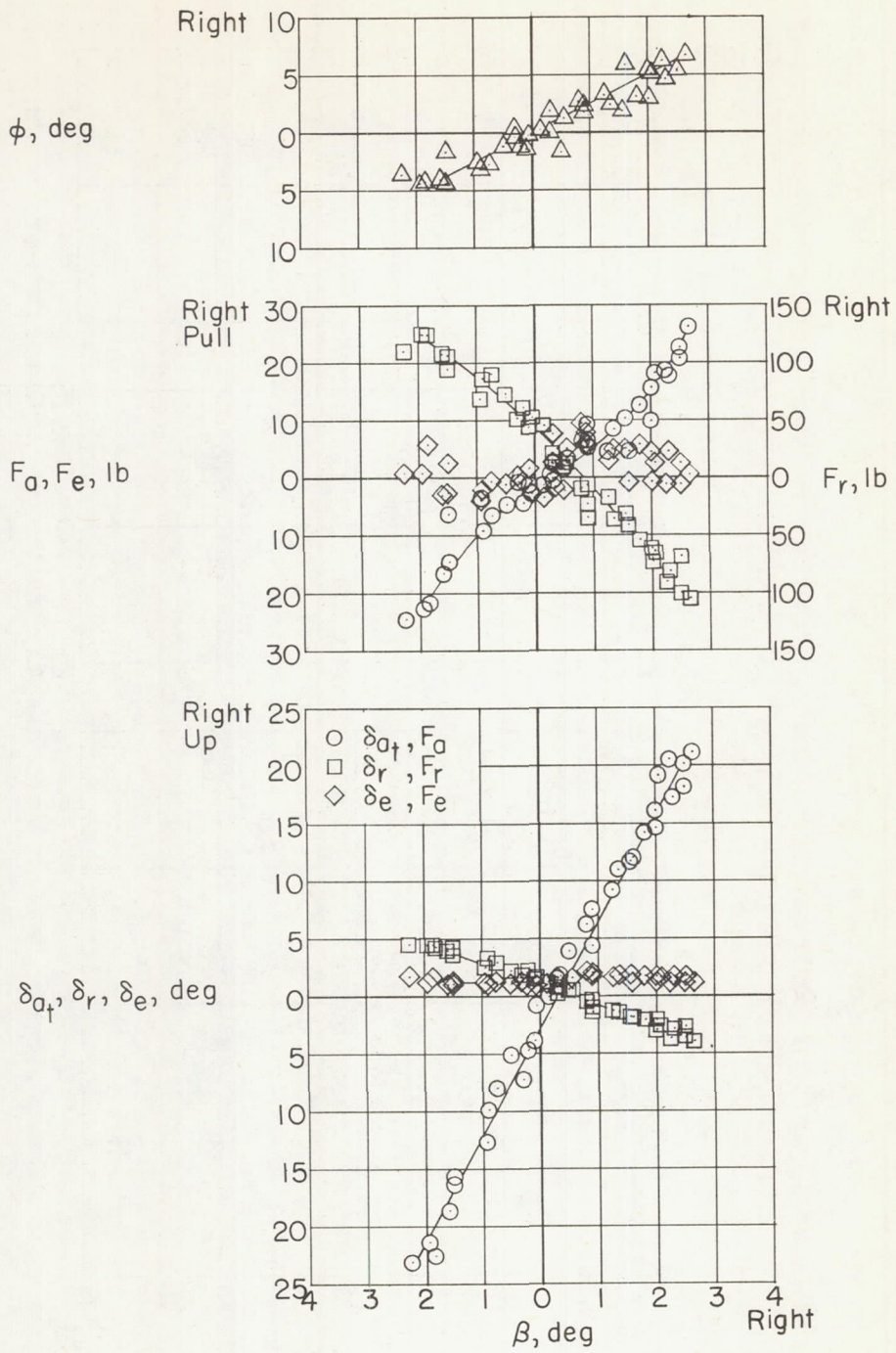

(b)  $M = 0.94$ ;  $h_p = 40,000$  feet.

Figure 6.- Concluded.

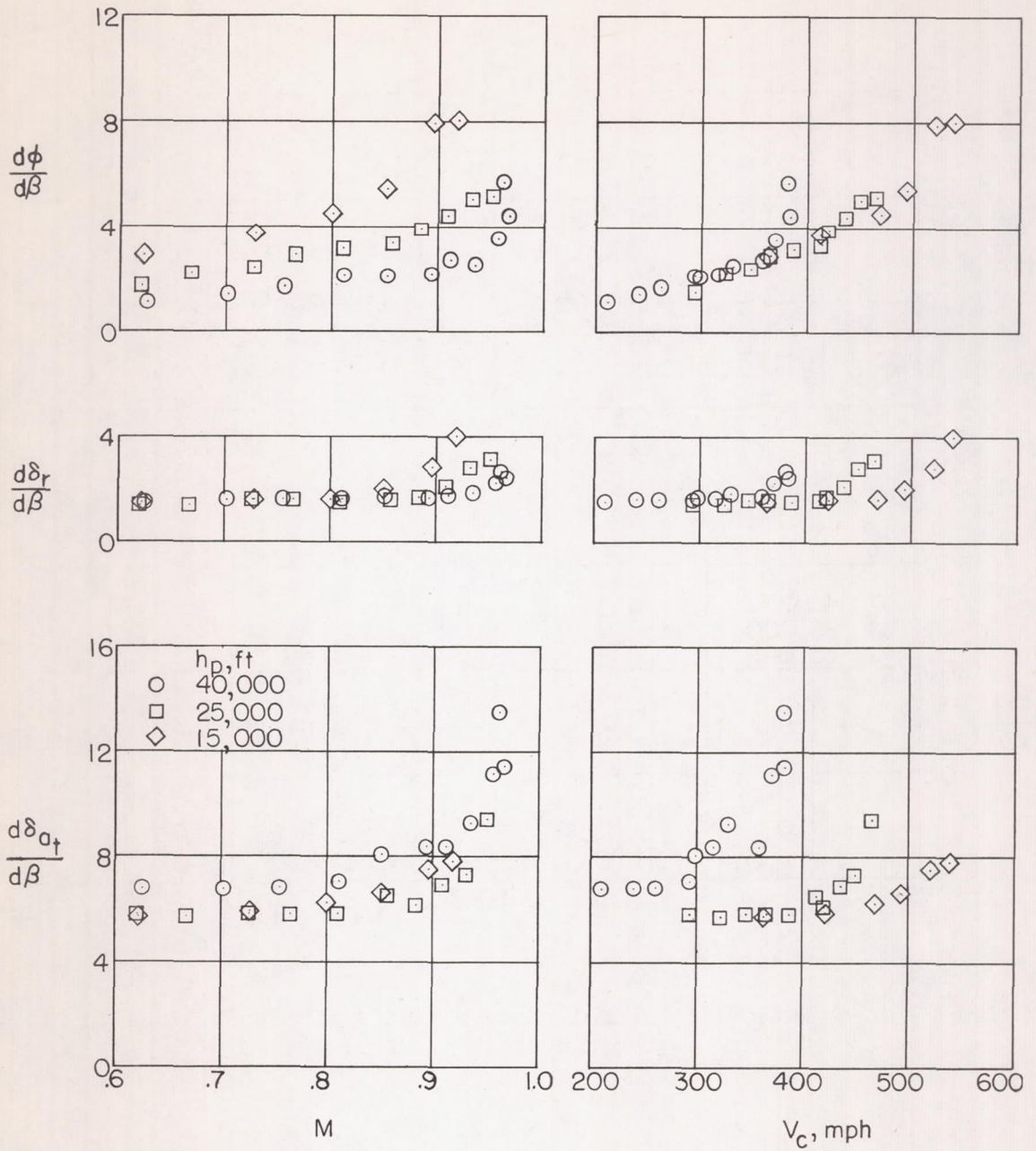

Figure 7.- Variation of several apparent lateral stability parameters with Mach number and calibrated airspeed.

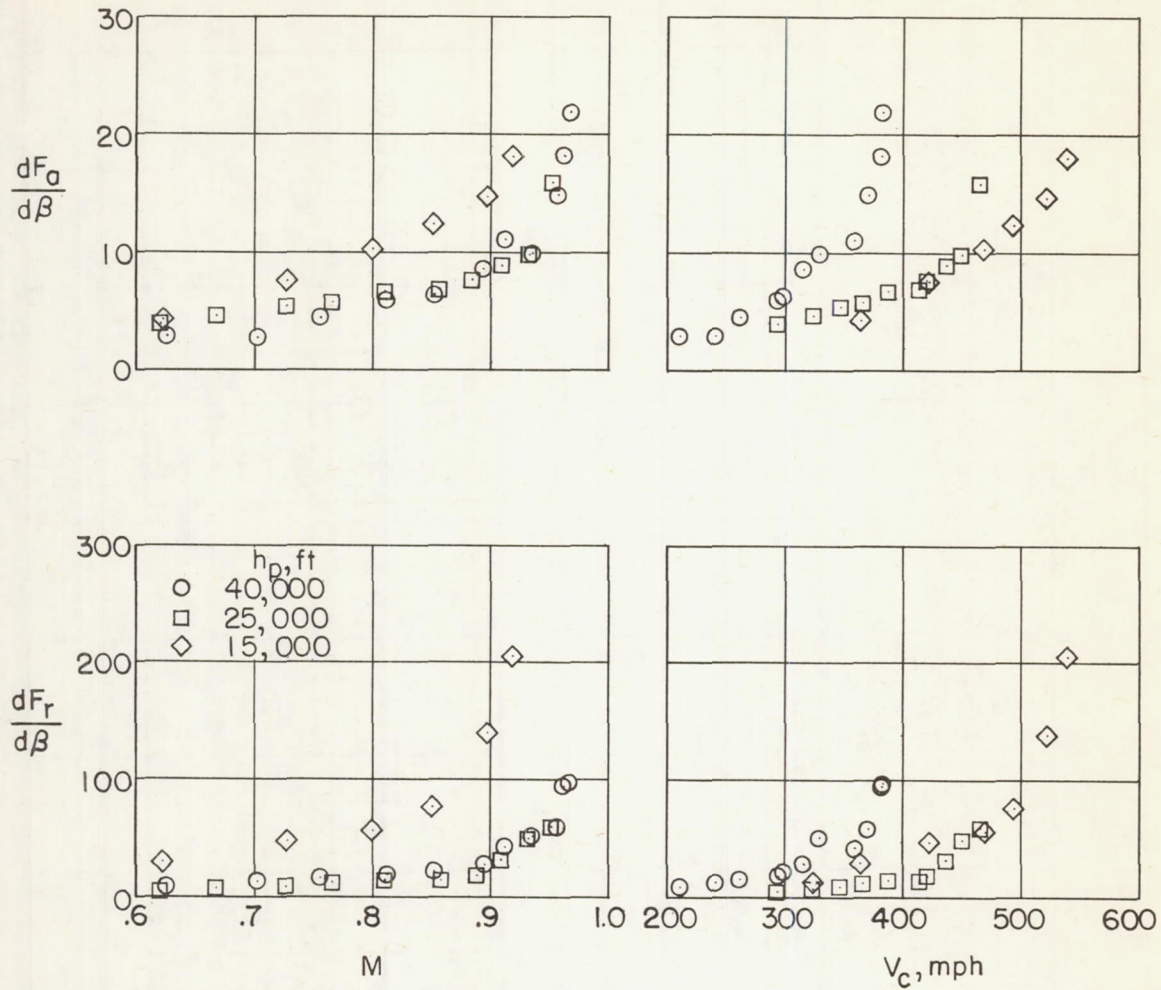

Figure 8.- Variation of control-force characteristics in sideslip with Mach number and calibrated airspeed.

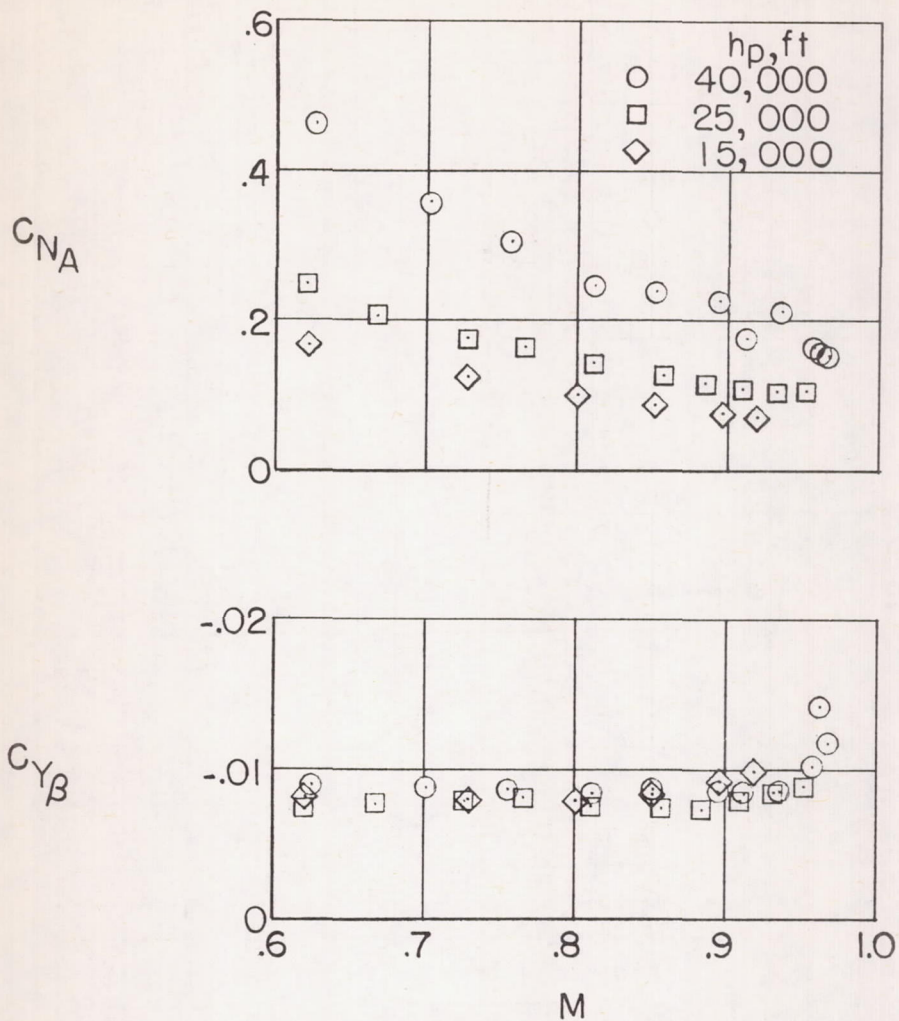
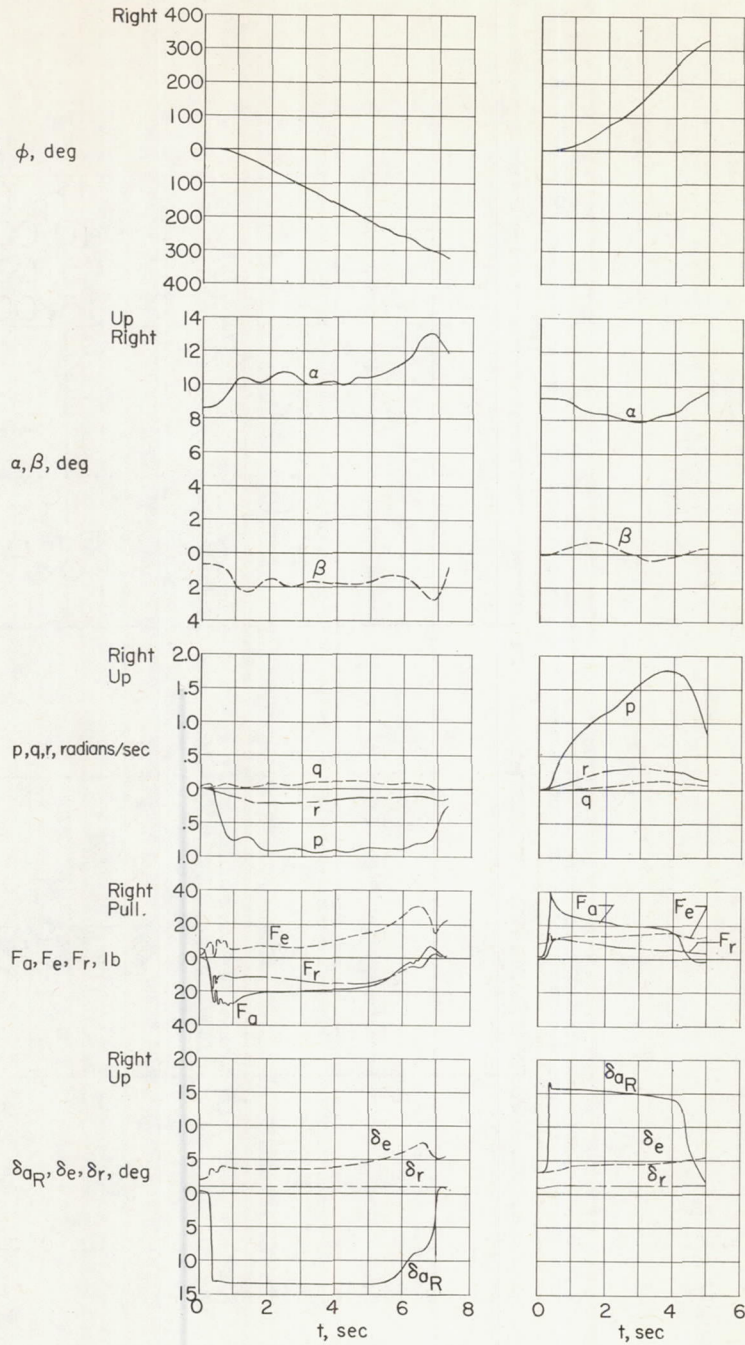
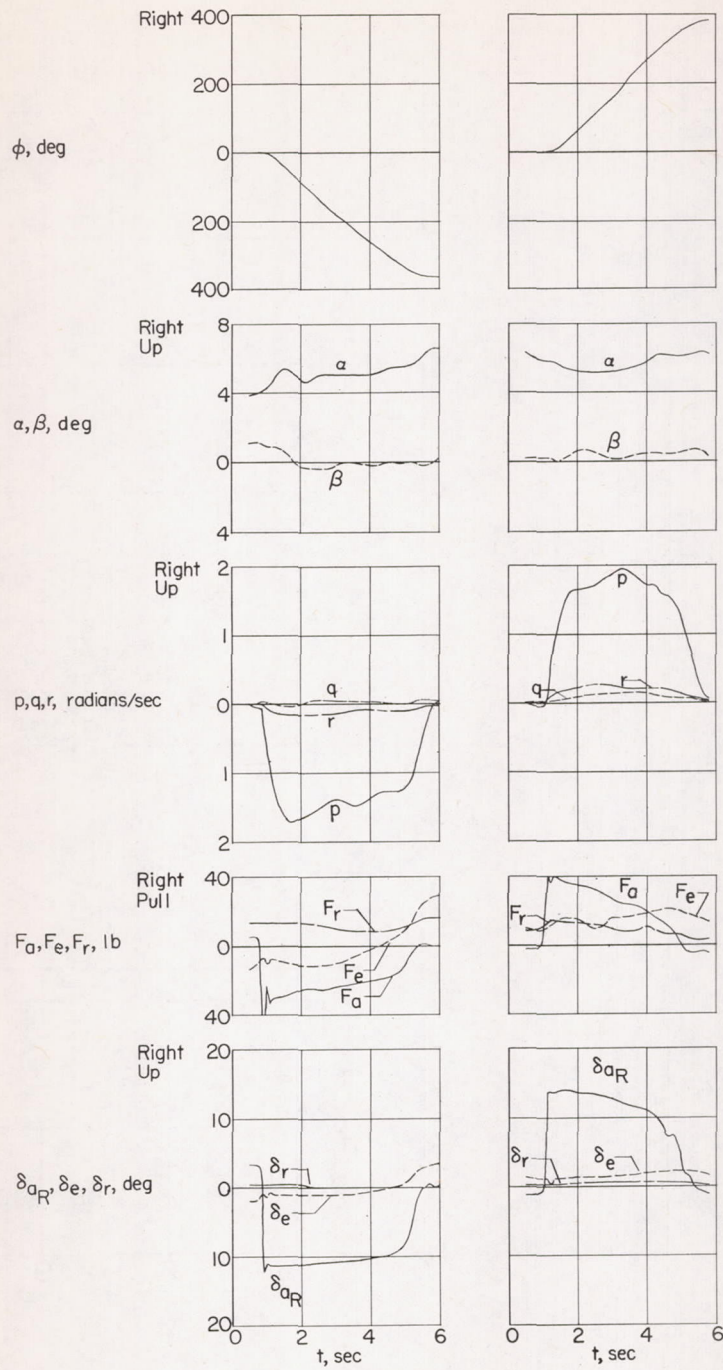

Figure 9.- Variation of  $C_{Y\beta}$  and  $C_{NA}$  determined in sideslip maneuvers at several altitudes.



(a)  $M \approx 0.77$ .

Figure 10.- Time histories of rudder-fixed aileron rolls performed at an altitude of 40,000 feet.



(b)  $M \approx 0.93$ .

Figure 10.- Concluded.

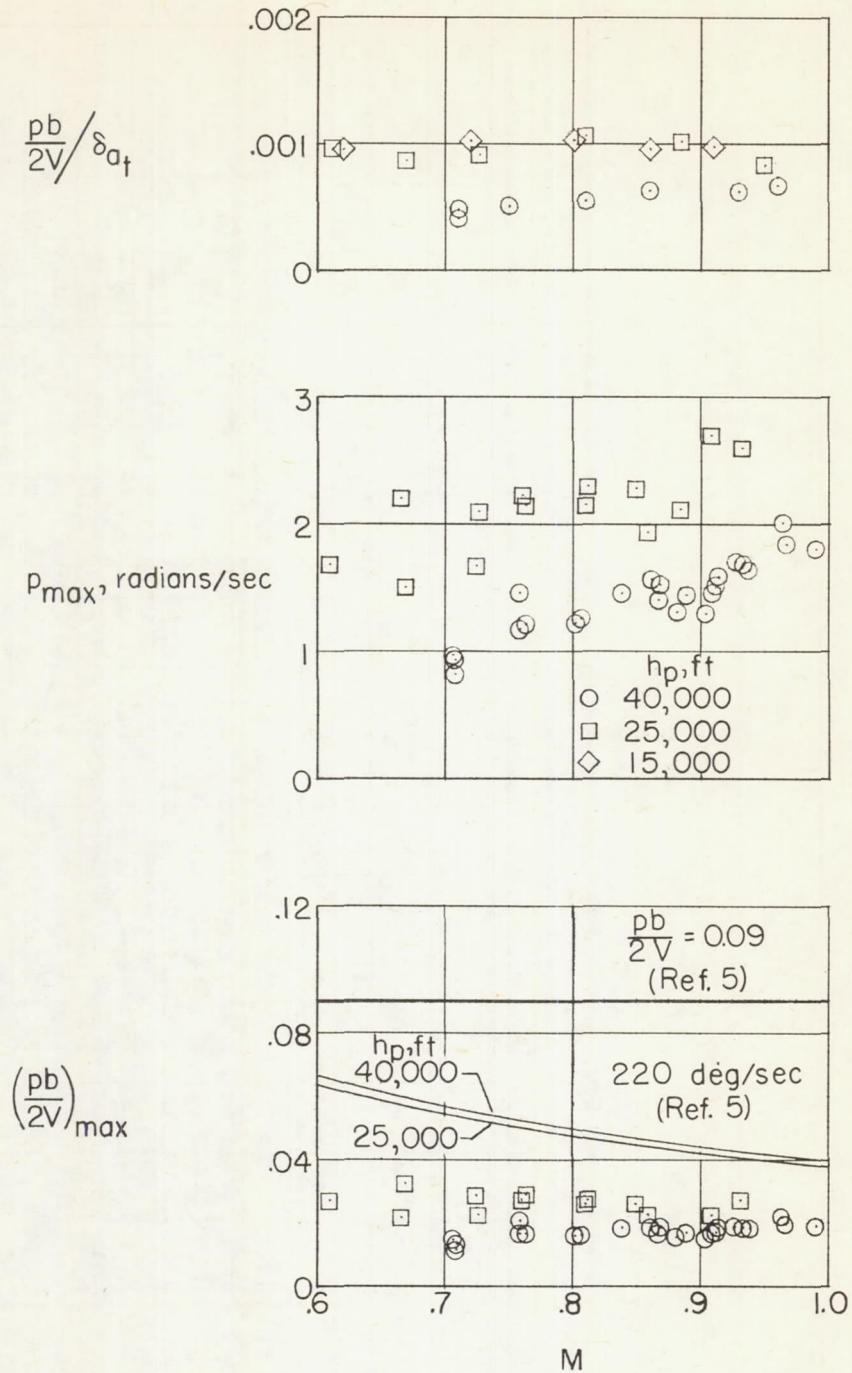

Figure 11.- Variation of aileron effectiveness, maximum rolling velocity, and maximum wing-tip helix angle with Mach number and comparison with the Military Specification.



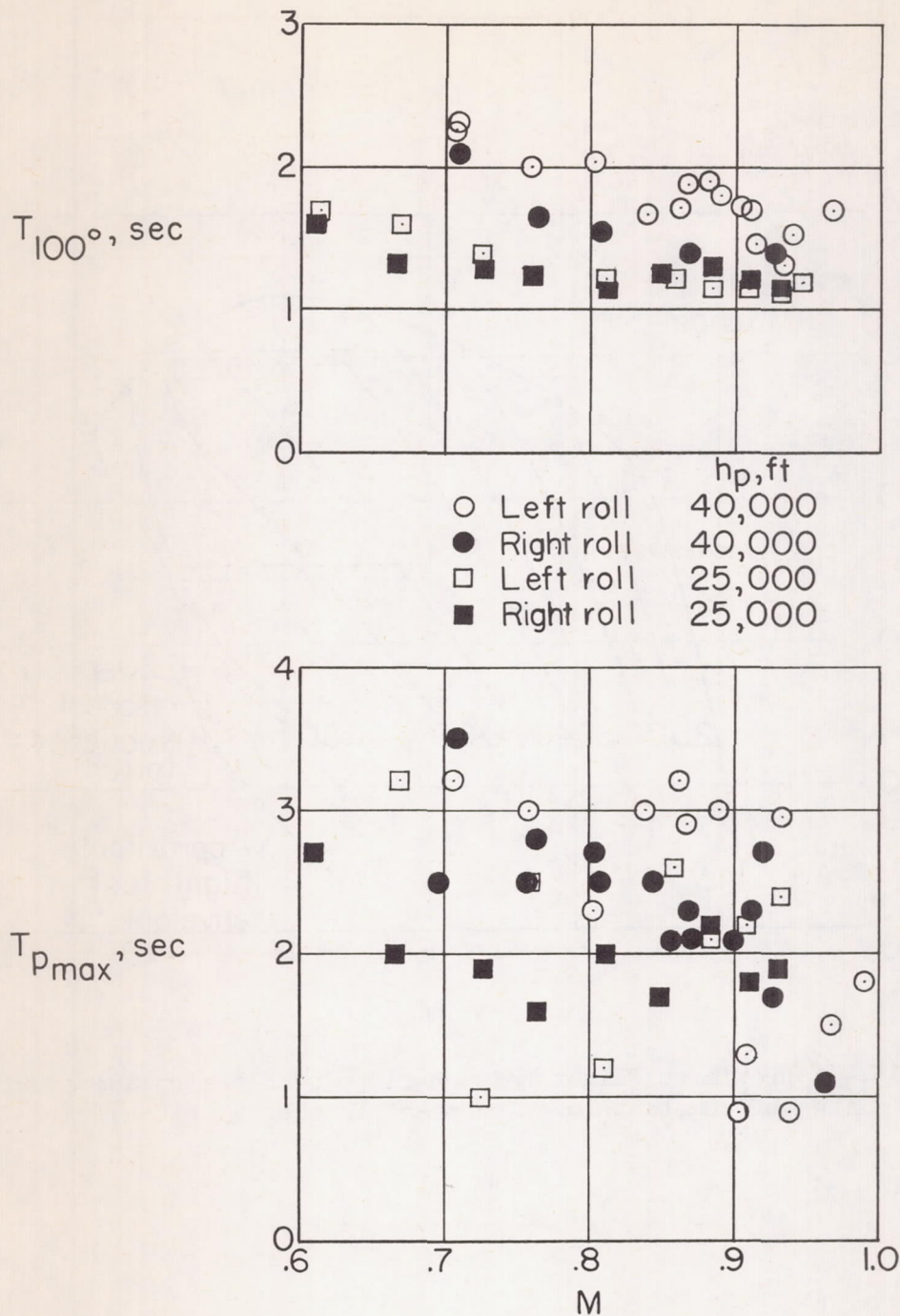

Figure 12.- Variation of time to bank to 100° and time to bank to maximum rolling velocity with Mach number for full-deflection rolls.

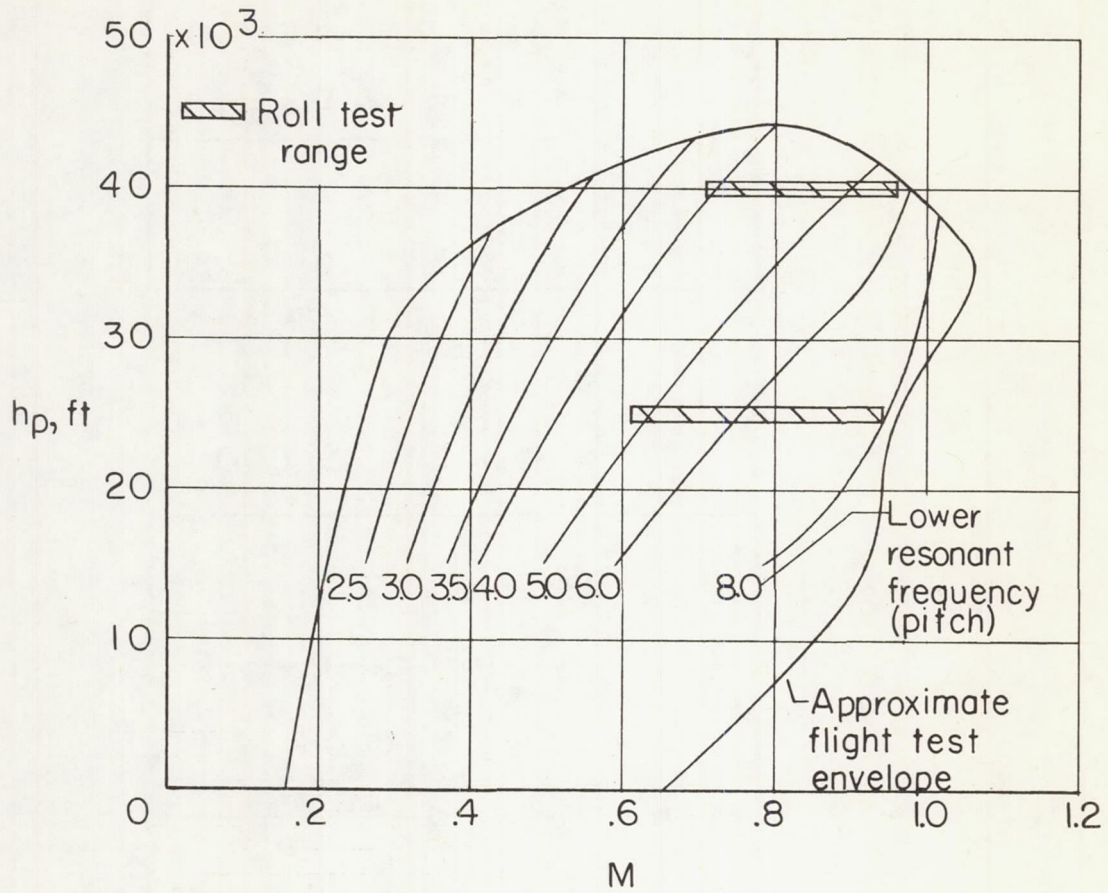
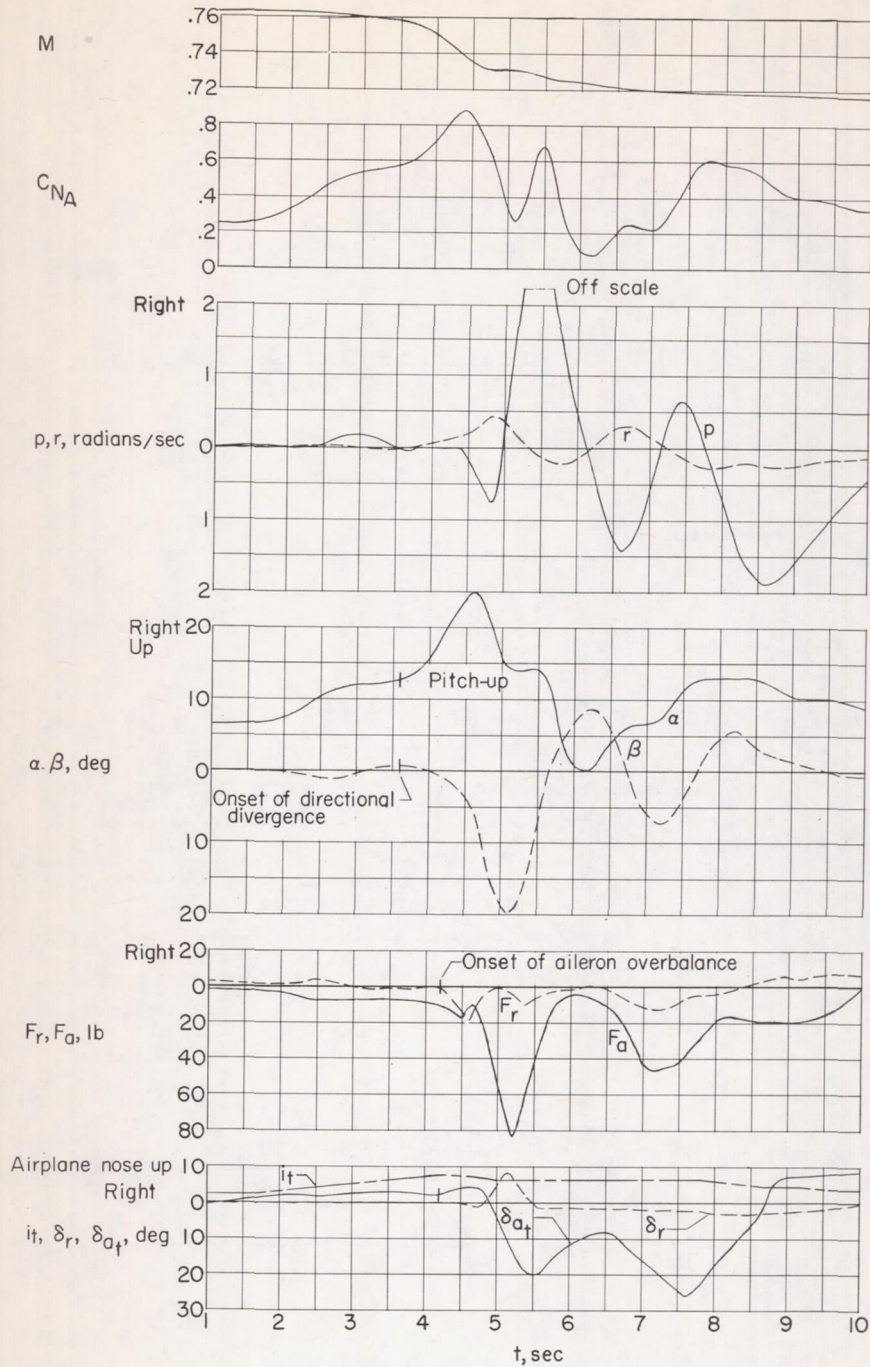
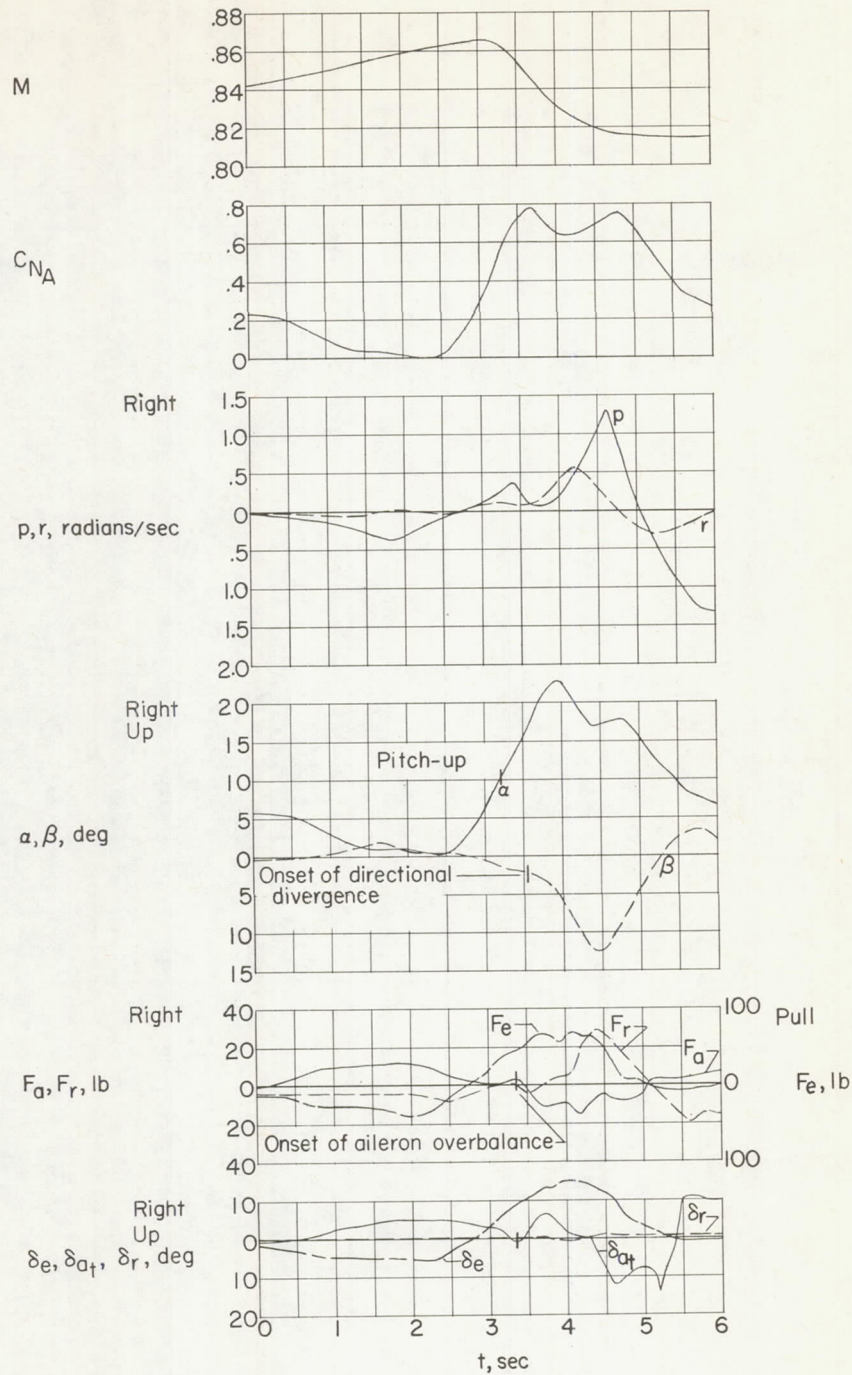

Figure 13.- Approximate flight test envelope of X-5 airplane showing lines of constant lower resonant frequency (pitch).



(a) Stabilizer pull-up.

Figure 14.- Examples of directional divergence and aileron overbalance at high lifts for an altitude of 40,000 feet.



(b) Elevator pull-up.

Figure 14.- Continued.

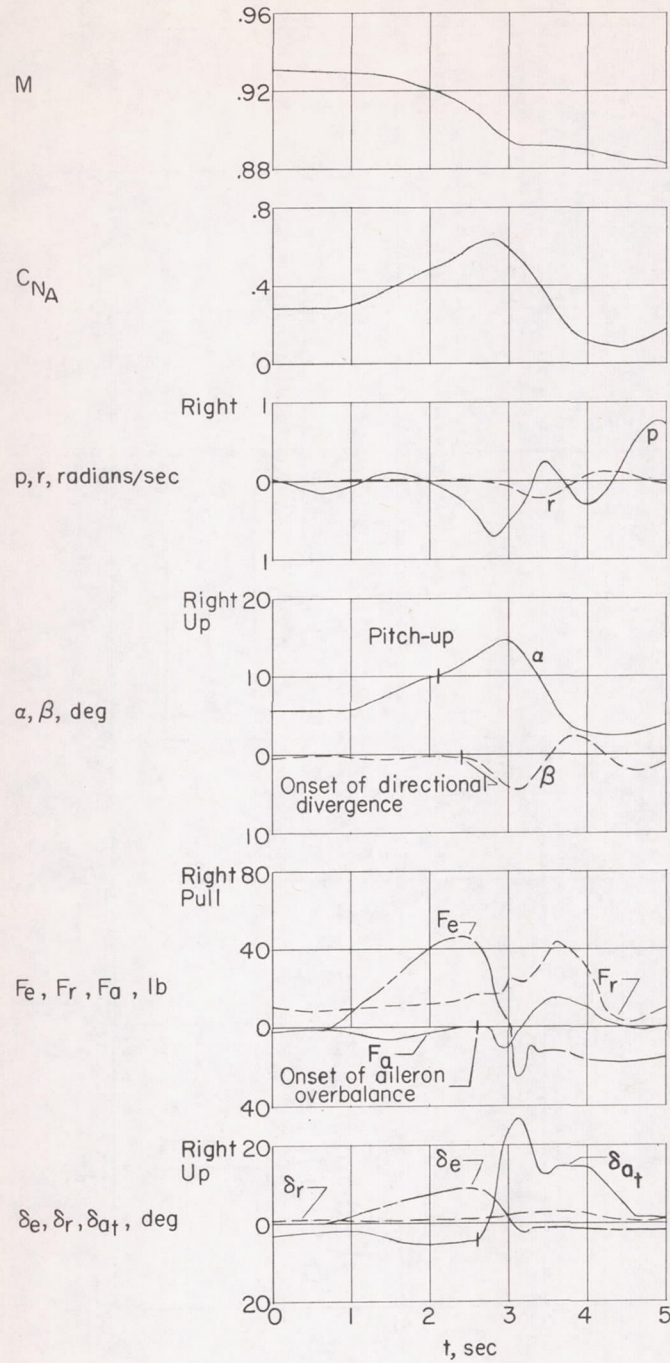

(c) Elevator pull-up.

Figure 14.- Concluded.

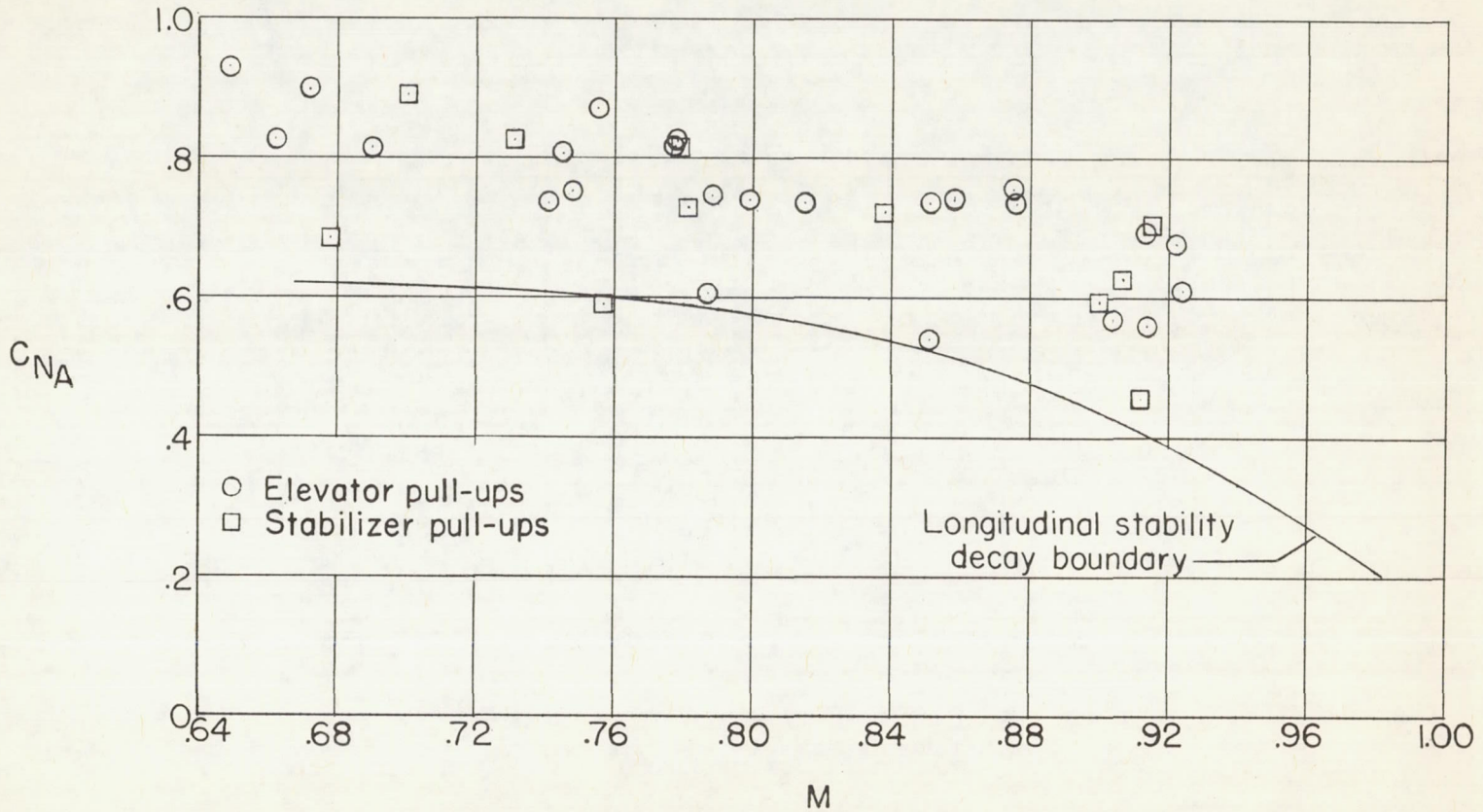

Figure 15.- Variation of  $C_{NA}$  with  $M$  for occurrence of directional divergence as compared with the longitudinal stability decay boundary.  $h_p = 40,000$  feet.

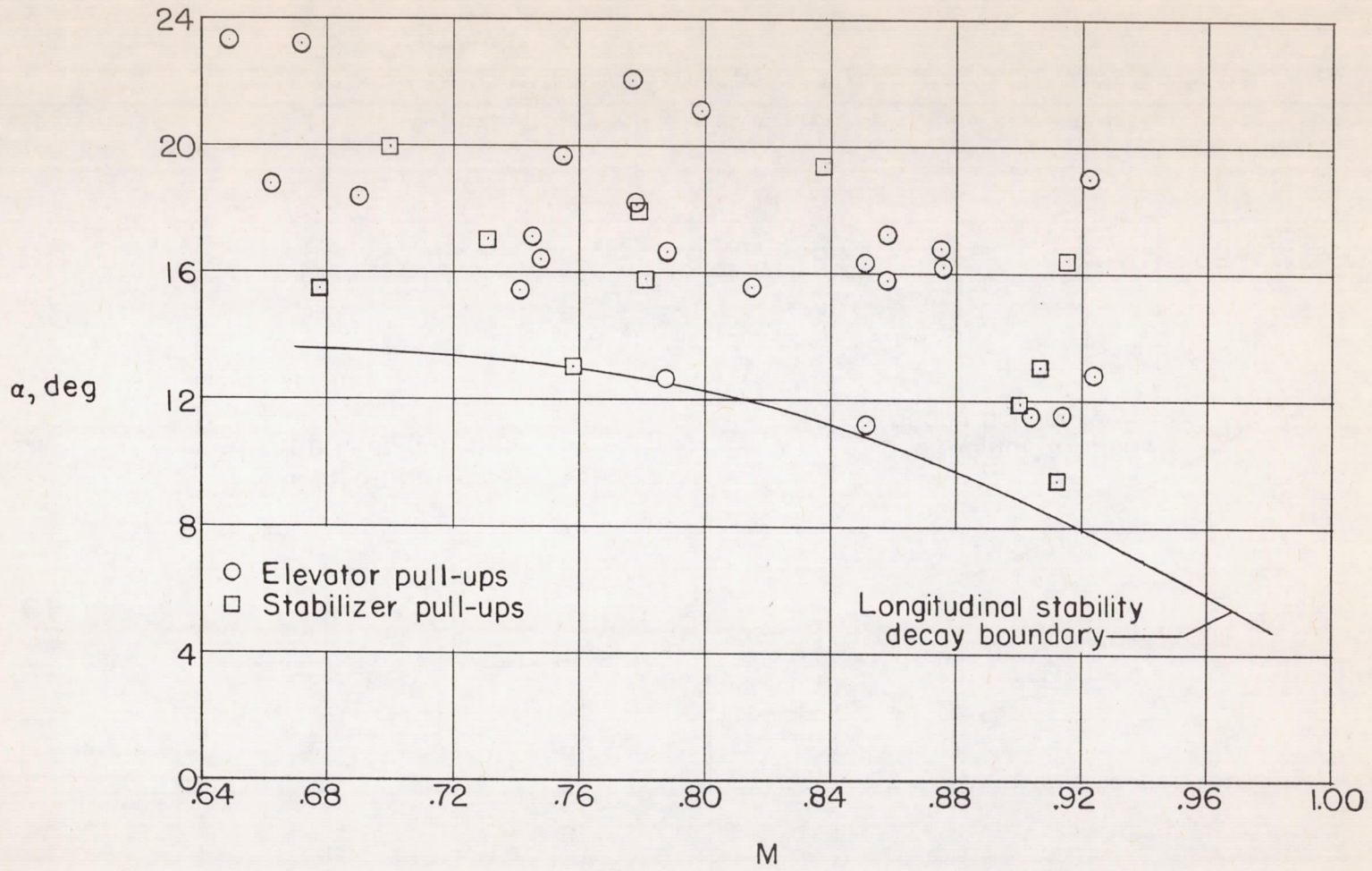

Figure 16.- Variation of  $\alpha$  with M for occurrence of directional divergence as compared with the longitudinal stability decay boundary.  $h_p = 40,000$  feet.

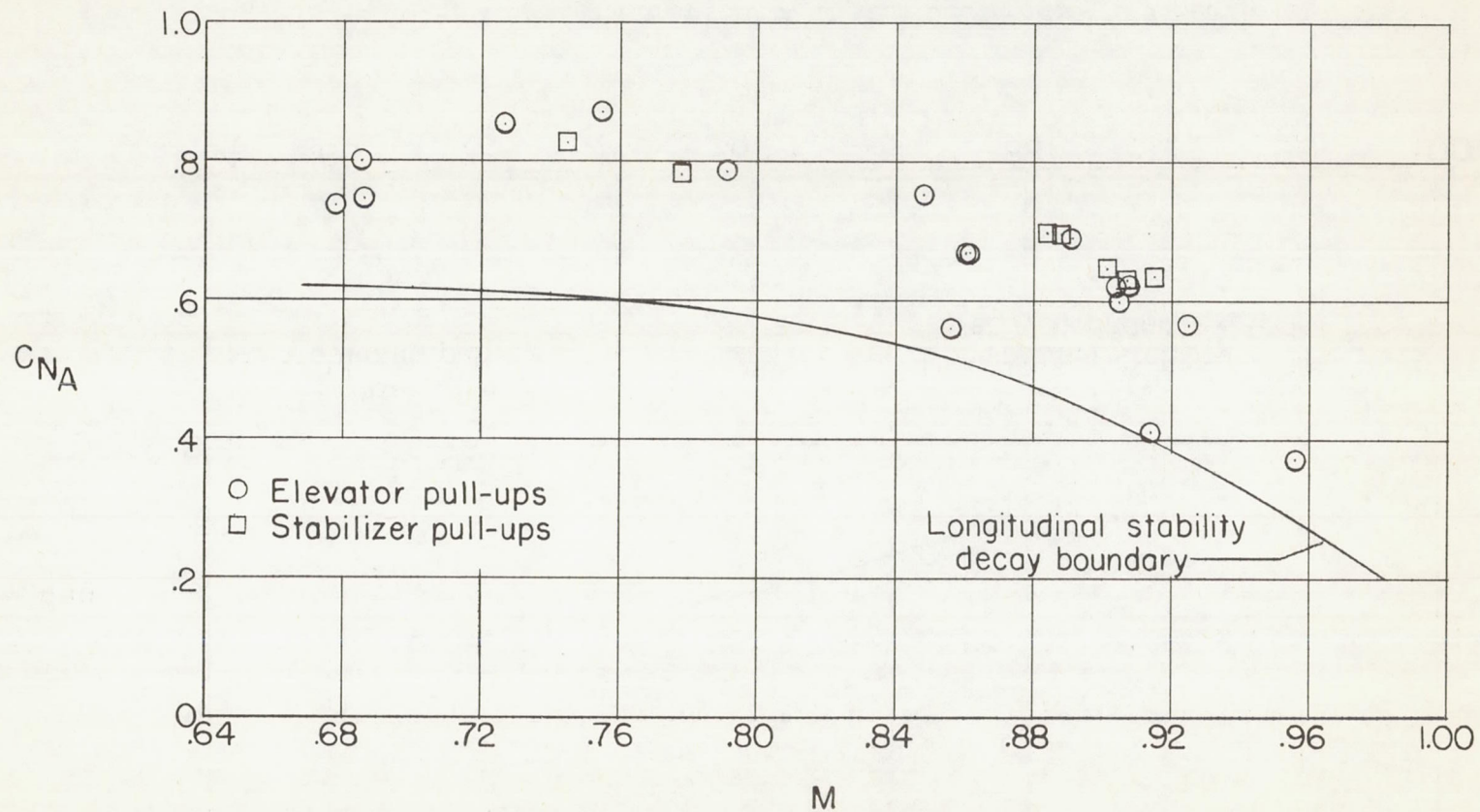

Figure 17.- Variation of  $C_{NA}$  with  $M$  for occurrence of aileron overbalance as compared with the longitudinal stability decay boundary.  $h_p = 40,000$  feet.



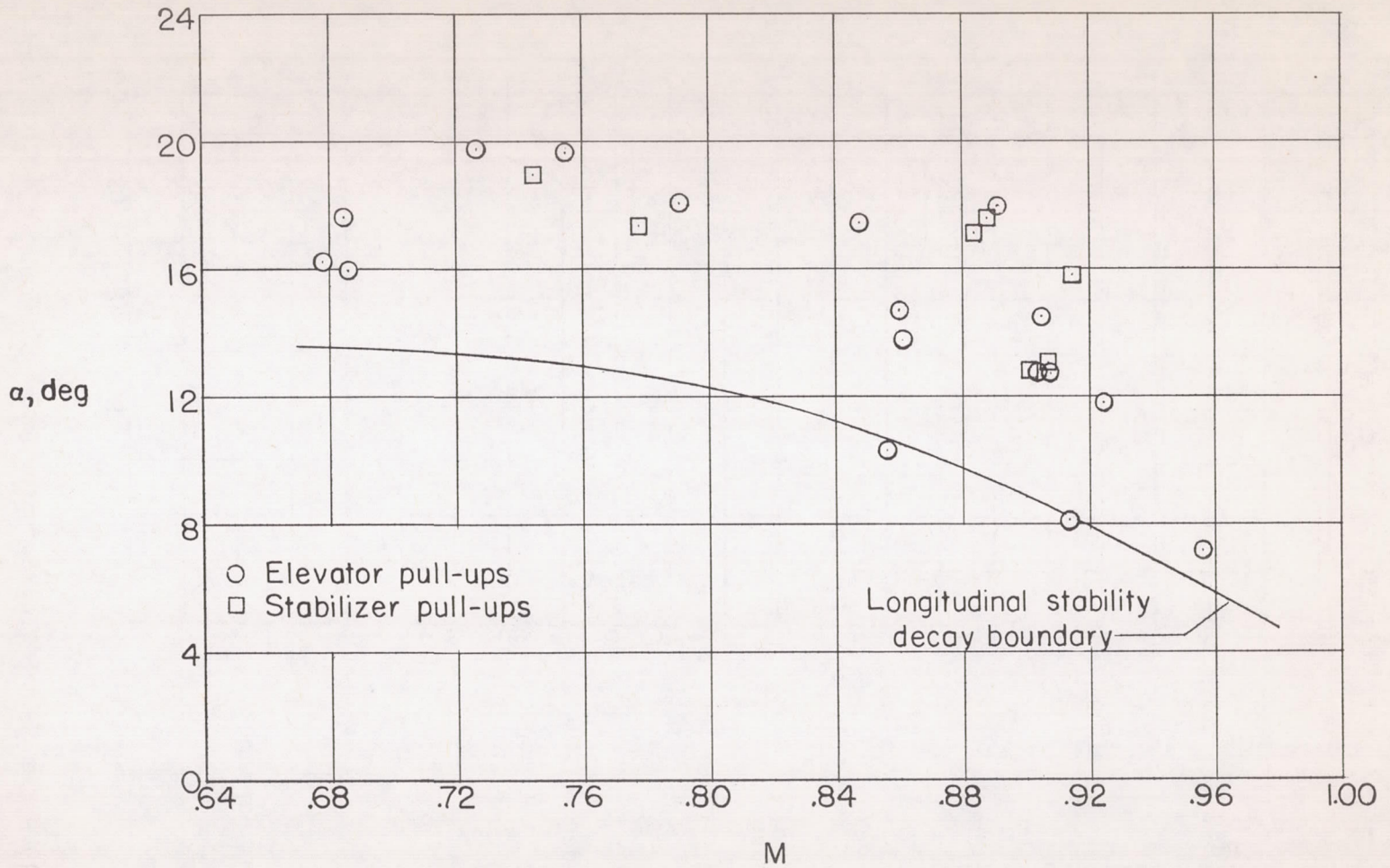

Figure 18.- Variation of  $\alpha$  with  $M$  for occurrence of aileron overbalance as compared with the longitudinal stability decay boundary.  $h_p = 40,000$  feet.

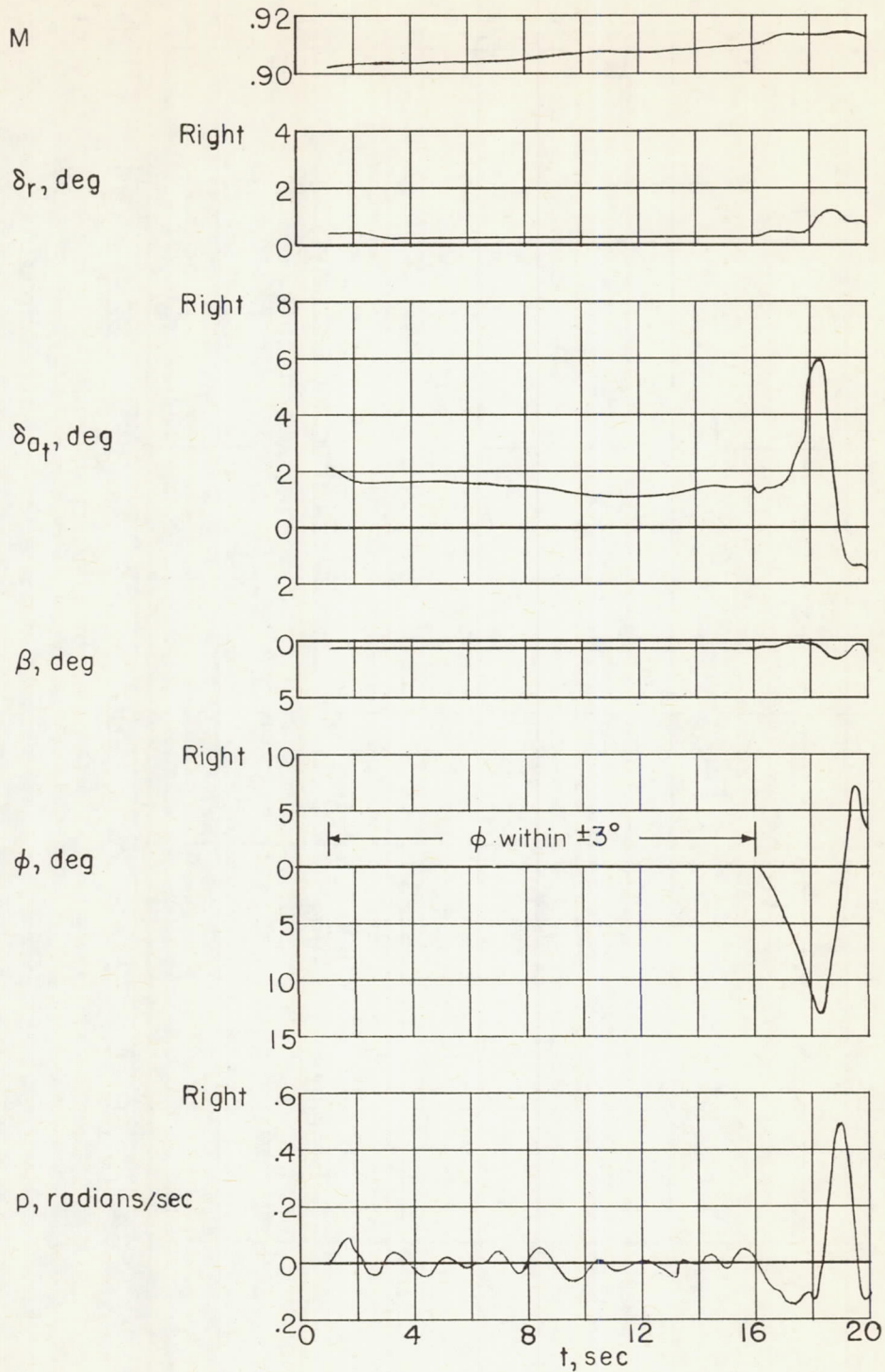

Figure 19.- Example of wing drooping at an altitude of 40,000 feet.

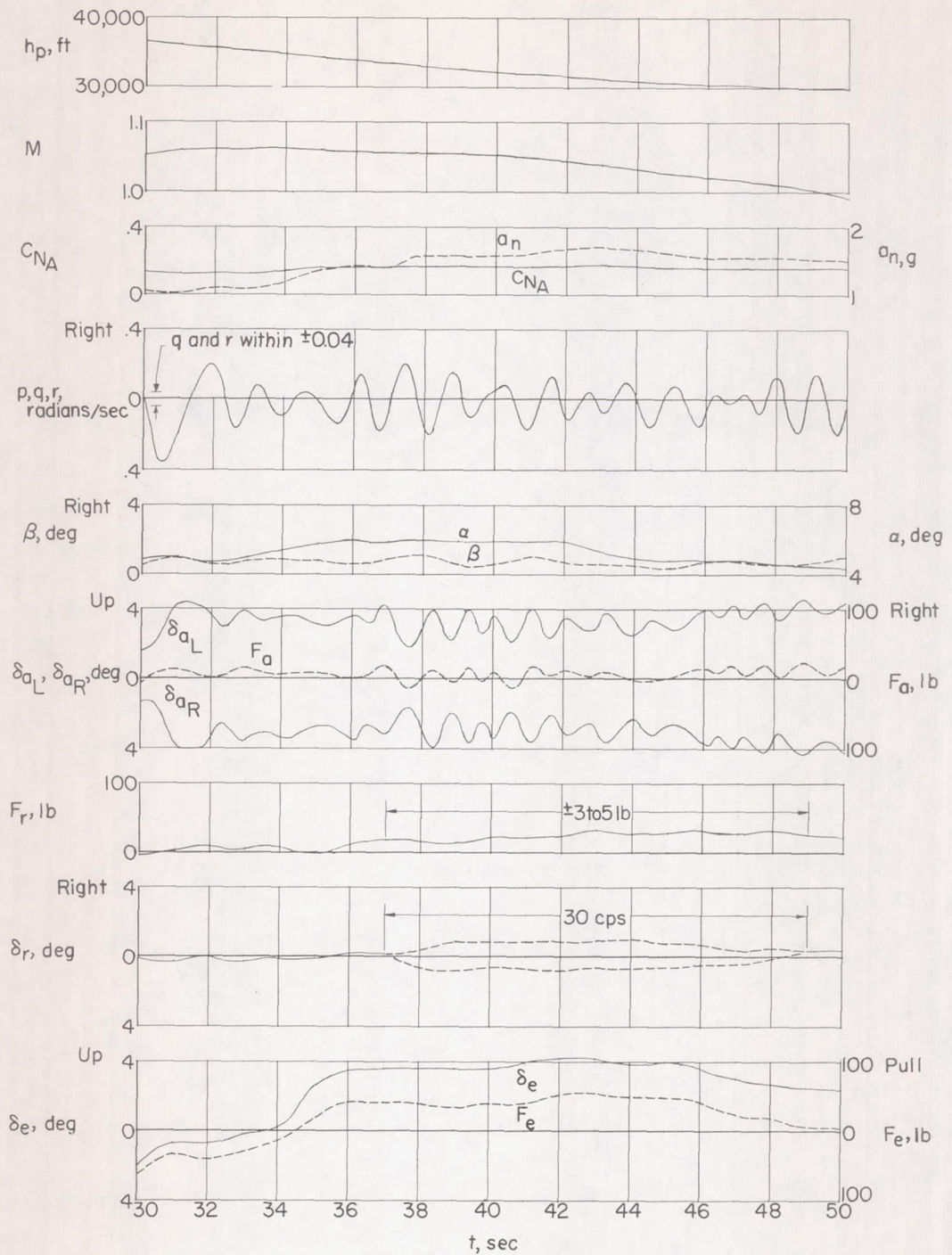

Figure 20.- Time history of quantities measured during single-degree-of-freedom flutter of the rudder.

