

32  
1  
2  
3

TECHNICAL MEMORANDUMS

NATIONAL ADVISORY COMMITTEE FOR AERONAUTICS

*Library. L.M.A.L*

No. 484

IGNITION POINTS AND COMBUSTION REACTIONS IN DIESEL ENGINES

By J. Tausz and F. Schulte

PART II

Communication from the Petroleum Research Laboratory  
of the Institute of Applied Chemistry  
Technical High School, Karlsruhe

**FILE COPY**

To be returned to  
the files of the Langley  
Memorial Aeronautical  
Laboratory  
Washington  
October, 1938



NATIONAL ADVISORY COMMITTEE FOR AERONAUTICS.

TECHNICAL MEMORANDUM NO. 484.

IGNITION POINTS AND COMBUSTION REACTIONS IN DIESEL ENGINES.\*

By J. Tausz and F. Schulte.

PART II.

B. Experimental Part

I. Measurement of the Ignition Point at Atmospheric Pressure

(1) Arrangement of the Ignition Tester

Our ignition point tester shown in Figure 1 is constructed along the same lines as that of H. Moore\* and consists of a round steel block A with a crucible-shaped recess a of 25 cc volume. This space was closed with a cover c fastened down with the screw d and fitted with a central opening 7 mm in diameter, through which the material under investigation was added in the form of drops or in a finely pulverized state in the case of solid substances. The shaft e contained the thermocouple. The oxygen or air for combustion was introduced through the opening b and preheated.

In order to obtain correct and accurately reproducible values in the measurements, careful construction of the ignition tester is necessary. Uniform heat distribution in the ignition

\*Communication from the Petroleum Research Laboratory of the Institute of Applied Chemistry, Technical High School, Karlsruhe. For Part I, see Technical Memorandum No. 483.

\*\*Journal of the Society of Chemical Industries, 8, 109 (1917).

block has hitherto been too little considered and this is the basis for the fact that the remarkable sharpness and definiteness of the ignition point, which makes it an accurate physico-chemical constant of the substance, has not previously been noted. The values obtained in the previously used types of apparatus showed large deviations and especially when measured in air were frequently incorrect.

The construction was undertaken in the following manner. The ignition block A was suspended in a crucible oven B which possessed a heavy fire clay lining and an outlet tube D, through which the burnt gases from the gas burner E could escape. In D a damper F was placed. In order to have on cooling as uniform heat distribution as possible throughout the ignition block, it was provided with a heavy asbestos covering, and insulation G was placed above the crucible. During the cooling, the damper F was closed, so that a decrease in temperature of 2-3°C per minute could be obtained.

The highest temperature obtained was 850°C which sufficed completely for the measurements.

The quantity of air or oxygen used in the ignition point measurements has hitherto not been accurately measured. An investigation showed, a quantity of air or oxygen corresponding to each size of crucible is necessary for accurate ignition point measurements. For the ignition block described having a crucible

volume of 25 cc, 200-300 cc of air and 70-80 cc of oxygen per minute were the most advantageous quantities of gas. With a slower stream of oxygen it took too long for the products of combustion from the preceding measurement to be expelled by the incoming oxygen.

If, as suggested above, large quantities of air or oxygen were used in the investigation, then with many substances the ignition points were too high since temperature equalization was not in that case complete and the thermocouple indicated a higher temperature than existed in the crucible. By using smaller quantities, the ignition point measurements were not as definite but the ignition points were not lower than when measured with the most advantageous quantity of gas. The quantity of air or oxygen used in the ignition point measurements was determined by means of a flow meter H, the adjustment of the velocity being effected by means of the stop-cock N. Each measurement was made four times, in air and oxygen, dry and moist. Sometimes water vapor had no effect, but frequently it shifted the ignition point either up or down. Traces of water were probably always present during the measurements, and its effect is being investigated still further.

When the measurements were conducted with moist gas, it was led through water contained in the glass flask K, the temperature of which was measured with a thermometer. By means of a gas flame, the water could be heated to the desired temperature

and various degrees of saturation of the gas with water vapor could be effected. In measurements with dry gas, it was led through two wash bottles L containing concentrated sulphuric acid. By adjustment of the three-way stopcock M, gas saturated with water vapor or freed from it could be used. The 96% oxygen was taken from a tank.

In all the experiments, the barometric pressure was indicated. Even in the first experiments, it was observed that repetition of the measurements sometimes indicated different values. The difference was indeed small but accurately determinable and could not be avoided although the experiments were conducted under the same conditions in a similarly clean ignition point crucible. Later the supposition was confirmed that the effect of the air pressure on the ignition point measurements caused the difference. Many substances show different values even with very small changes in air pressure, a condition which can only be clarified on the assumption of formation of molecular oxides. The change in the ignition point with pressure is extremely variable as has been already mentioned in the General Part. (Technical Memorandum No. 483, Part I).

All measurements were made with the temperature of the ignition block falling. Previous methods with constantly increasing temperature of the substance under investigation can never be so sharp and significant. Temperature equalization on cooling is always greater than on heating, since the crucible is heat lagged

and the damper F can be closed. The substance was always removed without residue on explosion above the ignition point, whereas when the temperature was rising, explosion first occurred on reaching the ignition point and yet a residue and decomposition products were present from the vaporized drops previously added, and the certainty of the measurement could be affected.

For the calibration of the thermocouple, the correctness of the temperature measurement was established as follows. An air stream (250 cc per minute) was passed through the tube b into the crucible and the ignition block was heated almost up to 650°C. The thermocouple was inserted in the opening in the crucible cover until it touched the bottom of the crucible. The end of the thermocouple was covered with asbestos to protect from the direct air stream. With the temperature falling, the deviations from the original temperature curve were determined and the corrected temperature curve was used in the measurements. These corrections are necessary, since complete temperature equalization at lower temperatures is not attained and the temperature in the inside of the crucible, which is of interest here, is not entirely the same as that indicated by the thermocouple during the experiments. At higher temperatures, both sets of thermocouple data agree completely. If the calibration is conducted without gas flow, then no difference in the two temperatures is ascertainable. The introduction of the substances investigated was effected in the case of liquids by means of a

pipette drawn down to a narrow point. A drop was sufficient for each experiment with very few exceptions which are specially indicated. With solid and semi-solid but low melting substances such as paraffin, tar, viscous oils, and so on, a piece of the material was attached to a clean iron wire and held over the opening in the crucible. By means of the emerging gas steam, a portion was melted and fell in the form of a drop into the crucible. Solid substances, such as oxalic acid, naphthalene, and so on, were introduced in a finely pulverized form with the help of a spatula. The quantity of substance thus introduced amounted to 15-30 milligrams.

## (2) Experimental Procedure

The experimental procedure should be indicated for a homogeneous chemical substance, in this case for n-Propyl alcohol. Air, dried in the sulphuric acid wash bottles, was led through the crucible (at the rate of 200-250 cc per minute). During this time, the ignition block was heated by means of the gas burner E and with rising temperature, at every 50°C a drop was permitted to fall into the crucible by means of the previously described pipette, until ignition occurred. This happened approximately at 460°C. Heating was then discontinued, the waste pipe was closed by means of the damper and while the ignition block cooled slowly, the substance was added in drops from time to time and allowed to explode, until ignition no longer occurred. The last ignition occurred at 446°C. By heating and cooling the

ignition block again in the manner described, further experiments were performed until the lowest values agreed regularly. Between each experiment, a time interval of about 1/4 to 1/2 minute must be allowed so that the products of combustion can be carried off by the gas stream. The same experiment was carried out with air which was saturated with water vapor at 27°C, thereby giving an ignition point at 430°C. Experiments in oxygen both dry and moist were conducted in the same way, except that the quantity of oxygen used per minute amounted to about 70-80 cc.

It is the nature of some substances, that on ignition point experiments they show uncertain results. In this case, the quantity of air or oxygen passed through can be increased or decreased in an attempt to obtain a definite ignition point. But frequently this is of no use. *check this with statement on page 27 T.M. #483* The uncertainty of the ignition point can be regarded as a characteristic property of some substances. It is likely dependent on the chemical properties which, under otherwise similar circumstances, make possible different intermediate stages and modes of combustion, of which any one may be favored by unknown chance conditions.

It is most advantageous to undertake the experiments in a partly darkened room or to set a hood above the ignition block arranged in the crucible oven so that the daylight may be shut out to a considerable extent. But in this case the decomposition products formed must have a good outlet and observation of the inside of the crucible must not be hindered. Before each series



of experiments and frequently also between experiments of the same series, the crucible was cleaned, which was accomplished by rubbing with asbestos and blowing out with a strong air current.

The terms "indistinct" and "irregular" used in connection with the experimental results have the following meaning. "Indistinct" applies to an ignition point, in which ignition occurs with development of considerable smoke and without appearance of flame, so that the observation is questionable. "Irregular" means that the ignition points obtained for a substance varied among themselves and the same ignition point could not be regularly obtained.

The danger of the values obtained by measurement in an iron ignition block being influenced\* by catalytic effects was avoided in that, with measurements on oils and other decomposable substances, the walls of the crucible were coated with a solid layer of graphite, which did not burn even at higher temperatures and in a stream of oxygen, and which excluded the influence of the iron walls.

### (3) The Effect of Vaporization of the Fuel and the Mixing with Air or Oxygen

Tests were made to determine in the first place whether, with the apparatus used, the air was sufficiently preheated in its relatively short passage; secondly, whether the method used in mixing the fuel and air influenced the ignition point; and

---

\*V. Meyer and Askenasy, Ann., 269, 49 (1892).

thirdly, whether a difference in the ignition point would arise with complete and incomplete vaporization of the fuel, that is, whether the method of adding the fuel affected the temperature at which ignition occurred. For this work, some measurements were made in the apparatus shown in Figure 2. The air or oxygen was introduced simultaneously through six narrow canals and thereby the preheating of the air and its mixing with the fuel was improved. The crucible volume was retained at 25 cc. The bottom of the crucible was drilled out and had as an extension a tube B, which with its removable cap reached into a heated bath C, the temperature of which exceeded the boiling point of the fuel used by 10-15°C. By this means, the fuel was completely vaporized with certainty. Heating of the ignition block was effected by four gas burners D. In order to protect the tube B from overheating by the gas flames, an enclosing tube E was fastened to the ignition block. The crucible cover G was inserted into the ignition block and fastened with a screw, so that it could not be hurled off by the occurrence of a violent ignition. A shaft was drilled in the ignition block for the thermocouple. The ignition block was provided with an asbestos covering to assist in uniform heat distribution.

The apparatus was set accurately in an upright position, the ignition block was heated with the gas flames D and the heating bath was brought for the time being to a temperature 10-15°C higher than that at which the substance under investiga-

tion boiled. It was only used for substances which boiled without decomposition and as in the previous work, 15-30 milligrams were added. The quantities of air and oxygen used were likewise the same as in the previous experiments (see page 2).

The values obtained with this apparatus showed complete agreement with those measured in the apparatus shown in Figure 1. The temperatures obtained with the first apparatus (Fig. 1) were always within the limits of error of the temperature measurements, which was equally true in this case. This agreement showed that the manner of distribution does not affect the height of the ignition point. Thus the temperature of ignition is independent of whether the fuel is present in the form of vapor or of fog and whether in this latter case, the drops are large or small. According to Haber and Wolff the explosive limits are changed very little thereby. On the other hand, as these investigators showed, the fineness of subdivision does influence the course and particularly the velocity of combustion and the velocity of propagation of the explosion flame.\*

(4) Experiments with the Ignition Point Tester  
of the Krupps Firm\*\*

Through the cooperation of the firm of F. Krupp at Essen, it was possible to make experiments with the improved commercial Moore type ignition point apparatus and to get values comparable with the results obtained in the apparatus used by us. The con-

---

\*Z. angew. Chem., 36, 373 (1923). See also General Part, Technical Memorandum No. 483, Part I, p. 41, regarding remarks on Wartenberg.

\*\*Wollers and Ehmke, Krupp. Monatsh., Jan., 1921.

struction of the Krupp's ignition point tester is good. The heating is electrical and the ignition block itself is made of rust-proof "V2A" material and is inserted in an electric oven. The cover closing the ignition crucible is screwed on. The apparatus is considered to be a laboratory instrument according to Wollers and Ehmke\* and E. Daiber.\*\*

In the experiments with this apparatus, many difficulties arose which are due to the fact that the crucible volume is too small. The ignition points in air were uncertain. In consequence of the small crucible, only 4 cc in volume, the addition of sufficiently small quantities of substance to correspond closely with this size of crucible was difficult. Also sufficient pre-heating cannot be counted on since the quantity of air introduced can only vary within narrow limits and can only be accurately regulated with difficulty since it corresponds to a small crucible volume.

On using oxygen, the apparatus can give useful values, whereas experiments with air cannot be conducted with certainty. On the other hand, as our results show, the measurement in air is necessary since by comparison with the results obtained in oxygen, a differentiation and more accurate evaluation of the fuel is possible. It has already been mentioned that the ignition points of various substances in air and oxygen do not stand in constant but rather variable relation to one another. According to the

---

\*Wollers and Ehmke, Krupp. Monatsh., Jan. 2, 1921.

\*\*E. Daiber, Z. Verein. deut. Ing., 65, 1289 (1921).

relation of the ignition points in air and oxygen, the change of the ignition point with increasing pressure can frequently be estimated, since the measurement in oxygen in general corresponds approximately to the measurement in air at 5 atmospheres, but not always (See Part I, Technical Memorandum No. 483, p. 9).

On account of the fact that the quantity of substance may readily become too large for the small crucible, the following disadvantages are evident: 1. If too large a drop (for example, of 15-20 mg weight, as falls from a finely drawn-out pipette) is allowed to fall into a small crucible, the explosive limit may readily be exceeded. 2. The ignition only occurs after a much longer time lag and is uncertain and more indistinct than with the larger crucible used by us. 3. With substances which boil without decomposition, the ignition points are about 3-5°C too high. 4. With substances which decompose on boiling, the ignition point of the decomposition products is approximately that measured on account of the small crucible, whereas in a large crucible in which the time lag is much shorter, the ignition occurs when a smaller part of the substance has decomposed. 5. A further disadvantage is the impossibility of obtaining measurements with a slowly cooling ignition block. If the ignition block remains in the electric oven, then many hours can elapse till an ignition point on cooling is measured, but if by means of the attached handle, the block is removed from the oven and allowed to cool in the outside air, then on account of the

relatively small heat conductivity of V2A steel, the case very readily occurs, that the temperature indicated by the thermocouple is not that existing in the crucible.

In summarizing, it can be said of the Krupp's ignition point apparatus that it serves the purpose for the work for which it was designed, namely, ignition point measurements of Diesel engine oils in a stream of oxygen. With small changes, it could also be made useful for ignition point measurements in air.

## (5) Comparative Table of Ignition Point Results of Various Authors

## Experiments in Oxygen

	Holm*	Wollers and Ehmke**	H. H. Moore***	Present work with dried oxygen
	°C	°C	°C	°C
Petroleum	380	---	252	250 - 265
Paraffin	310	246	245	243 - 258
Ethyl ether	400	-	-	178 <sup>↓</sup>
Ethyl alcohol	510	355	395	425
Acetone	570	-	-	568
Benzene, tech.	520	570	566	577
Aniline	530	-	-	530
Xylene, tech.	500	-	584	540
Methyl alcohol	-	500	524	555
Amyl alcohol	-	315	-	390
Hydronaphthalene	-	420	-	338
				Tetraline
Naphthalene	-	557	-	618
Toluene	-	563	596	552
				Pseudocumene
Cumene	-	485	-	533
Phenol	-	590	-	574
Acetic acid	-	492	-	560
Oxalic acid	-	595	-	616
Gasoline	-	-	272	265 - 315
Shale oil	-	-	251 - 253	270 - 290
Turpentine oil	-	-	275	278
Hexane	-	283	287	268
Heptane	-	-	281	-
Lubricating oil	-	-	265.5	260
Diesel engine oil	-	-	-	518

\*Holm, Z. angew. Chem., 26, 273 (1913).

\*\*Wollers and Ehmke, Krupp. Monatsh. 2, Jan., 1921.

\*\*\*H. Moore, J. Soc. Chem. Ind., 1917, p.109.

## (6) Ignition Point Tables

## Abstract of Tables

In the following tables, the ignition points of the substances investigated are listed. Each measurement was made four times, in air and oxygen, dry and moist. The water content when moist gases were used, was computed from the saturation pressure at the particular temperature and is given in grams per kilogram of gas.

The tables show the ignition points of the following groups of substances.

Table No.	G r o u p	
1.	Saturated aliphatic hydrocarbons, $C_nH_{2n+2}$ .	
2.	Unsaturated aliphatic hydrocarbons, $C_nH_{2n}$ .	
3.	Cyclic compounds and their derivatives.	
4.	Aromatic hydrocarbons.	
5.	Derivatives of aromatic hydrocarbons.	
6.	Terpenes and camphors.	
7.	Heterocyclic compounds.	
8.	Aldehydes.	
9.	Alcohols and their derivatives (mono-, di-, and polybasic alcohols).	
10.	Aliphatic acids (saturated and unsaturated) and acid anhydrides.	
11.	Aromatic acids and derivatives.	
12.	Oxalic acid, acetone, sucrose.	14. Essential oils.
13.	Fats and mineral oils.	15. Mixtures.



TABLE I.

Saturated Aliphatic Hydrocarbons  $C_nH_{2n+2}$ 

	A i r				O x y g e n			
	Bar. press.	H <sub>2</sub> O content	Igni- tion point	Time lag	Bar. press.	H <sub>2</sub> O content	Igni- tion point	Time lag
	mm Hg	g/kg	°C	sec.	mm Hg	g/kg	°C	sec.
Hexane	754.4	-	487	1	750.1	-	268	6
	752.3	12.7	500	1	750.2	22.2	260	7-8
Decane	746.0	-	463	1	750.2	-	202	5
	746.0	22.35	478	1	749.8	22.25	205	2
Paraffin I	754.0	-	409	1-2	758.6	-	250	5
	754.0	14.45	409	2	758.5	19.55	245	8
Paraffin II	754.0	-	414	1	751.1	-	243	6
	753.8	18.5	402	1	755.9	19.6	240	5
Paraffin III	753.5	-	388	1	758.5	-	258	6
	753.5	19.7	404	1	758.4	18.3	245	7

TABLE II.

Unsaturated Aliphatic Hydrocarbons (Ethylenic)  $C_nH_{2n}$ 

Amylene	-	-	-	-	753.7	-	332	5
	-	-	-	-	754.0	20.8	330	5
Diamylene	750.8	-	445	1	754.8	-	312	1
	750.8	18.5	457	1	755.0	24.8	310	3
Cetene	746.1	-	245	3-4	746.5	-	228	5
	746.0	23.7	250	2	746.5	16.85	230	6

TABLE III.

## Cyclic Compounds and Derivatives

	A i r				O x y g e n			
	Bar. press. mm Hg	H <sub>2</sub> O content g/kg	Igni- tion point °C	Time lag sec.	Bar. press. mm Hg	H <sub>2</sub> O content g/kg	Igni- tion point °C	Time lag sec.
Cyclopenta- diene	-	No ignition			739.5	-	414	3
	-	up to 650°			739.8	20.25	414	3
Methylcyclo- hexane	750.8	-	522	1*	748.0	-	290	3
	750.8	14.5	533	1*	748.2	22.3	295	3
1.3.4.tri- methyl- cyclohexane	751.8	-	475	1-2	744.1	-	270	4
	751.8	17.4	502	2-3	744.1	17.6	275	3
Cyclohexanol	751.2	-	530	0	740.0	-	325	6
	751.2	22.2	574	1	741.1	20.2	336	5
m-Methylcy- clohexanol	751.2	-	546	0	754.8	-	328	7-8
	751.0	22.2	607	1	759.0	24.7	338	5
o-Methylcy- clohexanol	751.2	-	574	0	754.8	-	336	6
	751.0	22.2	618	1	754.8	24.85	338	6
p-Methylcy- clohexanol	751.2	-	577	0	755.0	-	336	4
	751.0	22.2	626	1	755.0	26.3	345	4

\*Irregular

TABLE IV.

## Aromatic Hydrocarbons

	A i r				O x y g e n			
	Bar. press. mm Hg	H <sub>2</sub> O content g/kg	Igni- tion point °C	Time lag sec.	Bar. press. mm Hg	H <sub>2</sub> O content g/kg	Igni- tion point °C	Time lag sec.
Benzene, c.p.	-	-	740	-	742.5	-	662	5
	-	-	740	-	742.5	23.8	662	5
Benzene, tech.	-	-	730	2	752.5	-	577	2-4
	-	-	730	2	754.2	22.1	590	3-5
Toluene, tech. 2-3 drops necessary	-	-	810	3-4	742.7	-	552	5-6
	-	-	810	3-4	742.8	20.0	590	6
Xylene, tech.	-	-	750	2	742.5	-	540	6
	-	-	770	2	742.5	20.0	540	6
	No sharp ignition							
p-Xylene	-	-	-	-	745.1	-	552	3
	-	-	-	-	745.1	21.1	565	5
Ethyl benzene	749.2	-	490	3	752.1	-	500	3
	749.2	19.8	515	3	752.3	22.15	517	4
Mesitylene	-	-	720	2	751.0	-	610	2
	-	-	750	2	750.3	22.2	621	2
Pseudocumene	-	-	710	1-2	752.2	-	533	4
	-	-	710	1-2	750.3	22.2	533	3-4
Butyl toluene	750.8	-	574	2-3	743.9	-	520	2
	750.8	13.6	580	2-3	743.8	23.8	528	2
Hexaethyl benzene	757.8	-	490	1	748.0	-	383	1
	757.8	24.75	473	1	748.0	18.6	340	2
Hexadecyl benzene	746.8	-	385	2	748.5	-	230	4
	746.8	23.05	393	2	749.0	22.25	230	6
Triphenyl benzene	-	-	670	1	745.1	-	515	2-3
	-	-	670	1	745.1	21.1	563	3

Table IV (Cont.)

## Aromatic Hydrocarbons

	A i r				O x y g e n			
	Bar. press. mm Hg	H <sub>2</sub> O content g/kg	Igni- tion point °C	Time lag sec.	Bar. press. mm Hg	H <sub>2</sub> O content g/kg	Igni- tion point °C	Time lag sec.
Indene	-	-	650	1	751.5	-	484	3
	-	-	655	1	751.3	23.50	487	4
Naphthalene	-	-	700	3	756.2	-	618	1
	-	-	690	3	756.0	23.45	640	1
Tetrahydro- naphtha- lene	757.8	-	490	1	750.2	-	338	2
	757.8	17.4	473	1	750.0	22.25	336	3
Stilbene	751.1	-	585	1	739.8	-	502	3
	751.1	17.4	580	1	738.5	23.95	505	4
Acenaphthene	751.1	-	528	1-2	752.3	-	494	1
	751.1	18.55	520	1	750.5	22.25	478	2
Anthracene	-	-	605	1	751.2	-	540	2
	-	-	605	1	751.2	22.2	565	1
Retene	759.8	-	630	1	754.0	-	629	0
	759.8	21.95	598	1	754.5	24.85	565	3

TABLE V.

## Derivatives of Aromatic Hydrocarbons

	A i r				O x y g e n			
	Bar. press. mm Hg	H <sub>2</sub> O content g/kg	Igni- tion point °C	Time lag sec.	Bar. press. mm Hg	H <sub>2</sub> O content g/kg	Igni- tion point °C	Time lag sec.
Phenol, c.p.	-	-	715	0	745.0	-	574	2
	-	-	715	0.5	744.8	16.5	585	2
Phenol, tech.	-	-	-	-	750.8	-	494	1
	-	-	-	-	751.0	19.0	500	2
Pyrocatechol	752.0	-	643	0	757.8	-	490	0.5
	752.2	18.5	630	0	757.8	22.0	518	0.5
Hydroquinone	-	-	635	0	757.8	-	558	0-1
	-	-	655	0	785.0	18.3	558	1
Aniline	-	-	770	1.5	745.1	-	530	6
	-	-	773	2	745.1	21.1	540	4
Nitrobenzene	751.1	-	510	1	745.1	-	510	0
	751.0	20.9	520	0.5-1	745.1	21.1	525	0
Dinitrobenzene	750.0	-	510	1	752.0	-	508	0
	750.2	20.9	515	1	752.0	20.85	515	0
Trinitrophenol	751.6	-	360	2	755.6	-	435	0
	751.8	18.5	336	3-4	754.0	24.9	460	0

TABLE VI.

## Terpenes and Camphors

	A i r				O x y g e n			
	Bar. press. mm Hg	H <sub>2</sub> O content g/kg	Igni- tion point °C	Time lag sec.	Bar. press. mm Hg	H <sub>2</sub> O content g/kg	Igni- tion point °C	Time lag sec.
Pinene, c.p.	752.3	-	310	3	744.1	-	280	4
	752.2	23.5	315	3	744.1	18.7	282	4
Turpentine oil	753.0	-	300	3-4	758.2	-	278	1
	753.0	20.75	295	3-4	758.2	18.3	275	1
Sabinene	752.1	-	290	3	740.5	-	275	3
	752.1	23.5	298	1	739.8	21.25	287	2
Borneol	750.0	-	505	1	758.3	-	425	3
	750.1	20.9	481	1	758.3	24.75	407	2
Camphor	755.0	-	515	1	755.0	-	388	2
	755.0	20.75	520	1	755.0	20.75	406	2
Methene	751.4	-	574	0.5	755.0	-	295	3
	751.5	22.2	546	0.5	755.0	26.3	290	2

TABLE VII

## Heterocyclic Compounds

Pyridine	-	-	685	2	751.3	-	587	2
	-	-	685	2	751.3	23.55	593	2-3

TABLE VIII.

## Aldehydes

	A i r				O x y g e n			
	Bar. press.	H <sub>2</sub> O content	Igni- tion point	Time lag sec.	Bar. press.	H <sub>2</sub> O content	Igni- tion point	Time lag sec.
	mm Hg	g/kg	°C		mm Hg	g/kg	°C	
Formaldehyde	749.5	-	478	1	739.5	-	425	2
	749.8	22.25	491	1	739.5	15.7	435	1
Acetaldehyde	738.5	-	185	2	740.8	-	140	3
	738.5	13.85	190	2	740.8	15.6	143	3
Propylalde- hyde	746.3	-	280	3	744.1	-	260	2
	746.8	22.35	290	3-4	744.1	18.7	265	3
Valeralde- hyde, c.p.	750.8	-	417	1	754.8	-	200	2-3
	750.8	20.9	425	1	754.8	12.65	190	2-3
Valeralde- hyde oxidized	755.6	-	640	0*	754.7	-	240	1-2*
	755.8	13.55	648	0*	754.7	12.65	247	2*
Benzaldehyde	755.5	-	180	2*	754.8	-	168	3-6*
	755.5	13.55	180	2-3*	754.8	12.65	168	4-5*
Salicylalde- hyde	746.3	-	372	0.5	743.8	-	262	2
	746.0	23.7	362	1.0	744.1	17.6	260	3

\*Irregular

TABLE IX.

Alcohols and Derivatives  
Monobasic Saturated

	A i r				O x y g e n			
	Bar. press. mm Hg	H <sub>2</sub> O content g/kg	Igni- tion point °C	Time lag sec.	Bar. press. mm Hg	H <sub>2</sub> O content g/kg	Igni- tion point °C	Time lag sec.
Methyl alcohol	-	-	-	-	757.0	-	555	1-2
	-	-	-	-	751.2	22.2	540	3
Ethyl alcohol	751.0	-	558	1	757.0	-	425	5
	751.0	20.9	568	1	754.5	20.8	425	2
n-Propyl alcohol	753.0	-	505	1	750.0	-	445	5
	753.0	18.5	523	1	751.2	22.2	430	5
iso-Propyl alcohol	753.0	-	590	1	751.3	-	512	2
	753.0	18.5	560	1	751.3	23.5	512	3
n-Butyl alcohol	753.0	-	450	1	750.5	-	385	3
	753.0	18.5	478	1	750.3	23.55	383	4
tert-Butyl alcohol	-	-	-	-	755.3	-	500	4
	-	-	-	-	755.0	26.3	502	3
active-Amyl alcohol	749.1	-	409	1	750.5	-	390	3
	749.1	19.8	445	1	750.5	23.55	385	4
Ethyl ether	751.6	-	343	0	758.0	-	178	6-7
	751.6	17.4	357	0	754.5	19.65	180	6-7
Monobasic Unsaturated								
Allyl alcohol	749.1	-	367	1	754.1	-	406	3
	749.1	19.8	350	1	754.1	20.8	385	6
Tribasic								
Glycerine	751.9	-	500	3-4	744.1	-	414	1
	751.9	20.9	500	3-4	744.1	22.4	425	1
Polybasic								
Mannitol	750.2	-	475	1	749.0	-	400	4
	750.0	22.25	484	1-2	749.0	9.30	414	2



TABLE X.

Saturated Acids  $C_nH_{2n}O_2$ 

	A i r				O x y g e n			
	Bar. press. mm Hg	H <sub>2</sub> O content g/kg	Igni- tion point °C	Time lag sec.	Bar. press. mm Hg	H <sub>2</sub> O content g/kg	Igni- tion point °C	Time lag sec.
Formic acid	-	-	650	0	No ignition up to 680°			
	-	-	645	1				
Acetic acid	-	-	665	0	752.1	-	560	0
	-	-	655	1	752.1	22.15	563	1
Heptylic acid	751.0	-	602	1	739.5	-	260	4
	751.0	17.4	590	1	739.5	16.6	270	3
Nonylic acid	750.8	-	391	1	744.0	-	250	3
	750.8	18.5	414	1	744.1	17.6	235	5
Lauric acid	748.5	-	533	2-3	744.0	-	275	5
	748.5	21.0	515	2-3	744.1	17.6	275	4
Palmitic acid	751.2	-	425	1	758.8	-	245	5
	751.1	19.7	438	1	758.8	20.7	252	3
Stearic acid	750.8	-	430	1	758.6	-	250	6
	750.8	20.9	432	1	758.8	20.7	258	3-4
Unsaturated Acids								
Undecylenic acid	750.8	-	338	1-2	749.8	-	245	4
	750.8	19.75	345	1-2	749.9	22.25	235	5
Acid Anhydrides								
Acetic anhy- dride	751.5	-	585	1*	752.1	-	432	3
	751.5	15.4	555	1*	752.1	20.9	438	2
Butyric an- hydride	753.9	-	320	2-3	750.5	-	370	3
	753.9	17.35	322	2	754.5	20.8	357	3
Valeric an- hydride	753.0	-	320	3	754.1	-	365	4
	753.0	16.3	322	2-3	754.1	20.8	362	3

\*Indistinct

TABLE XI.

Aromatic Acids and Derivatives  
Monobasic Saturated

	A i r				O x y g e n			
	Bar. press. mm Hg	H <sub>2</sub> O content g/kg	Igni- tion point °C	Time lag sec.	Bar. press. mm Hg	H <sub>2</sub> O content g/kg	Igni- tion point °C	Time lag sec.
Benzoic acid	-	-	710	0	751.8	-	590	1-2
	-	-	710	0	754.1	22.4	585	1
Ethyl ben- zoate	-	-	675	0.5	756.1	-	580	0
	-	-	670	1	756.2	24.8	593	3
Hydrocinnam- ic acid	751.0	-	612	1	752.3	-	500	5
	751.0	17.4	600	1	753.0	20.85	490	4
Monobasic Unsaturated								
Cinnamic acid	-	-	640	0.5	752.5	-	525	3-4
	-	-	640	0.5	753.0	20.85	515	4

TABLE XII.

Dibasic Saturated Acids

Oxalic acid	-	-	725	0.5	755.4	-	618	1
	-	-	725	1.0	755.5	19.65	596	1
Ketones								
Acetone 2-3 drops necessary	-	-	700	2-3	757.0	-	568	4-5
	-	-	700	2-3	740.0	20.05	574	5
Carbohydrates								
Sucrose	749.8	-	385	1-2	742.3	-	378	1
	749.9	22.25	404	3-4	742.3	20.2	378	1

TABLE XIII.  
Fatty and Mineral Oils

	A i r				O x y g e n			
	Bar. press. mm Hg	H <sub>2</sub> O content g/kg	Igni- tion point °C	Time lag sec.	Bar. press. mm Hg	H <sub>2</sub> O content g/kg	Igni- tion point °C	Time lag sec.
Auto oil (Poland)	753.3	-	430	1*	739.6	-	260	5
0.92-0.93 Sp.Gr.	753.3	11.25	417	1*	739.6	16.60	260	6
American cylinder oil	752.7	-	417	3	745.1	-	320	3
	752.7	20.85	412	3	745.1	19.9	310	5
Pennsylvania crude oil	752.9	-	367	0.5	746.3	-	242	6
	752.9	23.5	375	0.5	749.4	20.95	245	7
Shale oil I (Wurttemberg)	757.5	-	435	1	754.8	-	290	2-3
	757.5	20.7	468	1	754.8	24.85	288	2
Shale oil II (Wurttemberg)	752.6	-	397	1	745.5	-	275	4
	752.6	23.5	412	1	745.5	20.05	288	3-4
Shale oil III (Baden)	752.8	-	393	1	745.0	-	275	3
longitudinal fracture	752.8	23.5	406	1	745.0	19.9	285	2-3
Shale oil IV (Wurttemberg)	752.2	-	397	1	744.9	-	282	3
	752.2	23.5	412	1	744.9	21.1	290	3
Shale oil V (Wurttemberg)	752.8	-	354	1	745.0	-	275	3
	752.8	23.5	367	1	745.0	19.9	285	2-3
Shale oil VI (Wurttemberg)	752.0	-	354	1	744.8	-	272	5
	752.0	23.5	362	1	744.8	18.65	280	5
Shale oil VII (Wurttemberg)	752.2	-	357	1	744.6	-	270	7
	752.2	23.5	372	1	744.6	18.7	275	6
Shale oil VIII (Sweden)	753.2	-	460	1	744.7	-	278	5
	753.2	14.5	463	1	744.7	19.9	285	5
Shale oil IX (Wurttemberg)	752.1	-	357	1	745.0	-	270	3
	752.1	23.5	367	1	745.0	21.1	278	3-4

\*Indistinct

Table XIII (Cont.)  
Fatty and Mineral Oils

	A i r				O x y g e n			
	Bar. press. mm Hg	H <sub>2</sub> O content g/kg	Igni- tion point °C	Time lag sec.	Bar. press. mm Hg	H <sub>2</sub> O content g/kg	Igni- tion point °C	Time lag sec.
Linseed oil	741.0	-	463	1	742.3	-	285	4**
	741.0	21.2	463	1.5	742.3	21.15	290	4**
Wood oil	753.1	-	430	7-8	744.8	-	357	3
	752.9	18.5	409	4-5	744.8	19.9	340	3
Coal tar oil	No ignition up to 650°				755.8	-	518	4
					755.8	23.4	528	2
Petroleum I (America) kerosene	738.5	-	290	1-2	746.4	-	265	5
	739.0	13.85	295	1-2	746.4	16.5	270	6
Petroleum II (Poland) re- fined naphtha	739.4	-	300	1	744.5	-	265	6
	738.8	16.65	336	1	744.5	21.1	270	6
Petroleum III (Poland) re- fined solar oil	738.4	-	310	1	741.0	-	265	4
	738.4	15.7	336	1	741.0	17.7	270	6
Petroleum IV (India) kerosene	741.5	-	435	1	745.0	-	250	6
	741.5	16.6	457	1	745.0	19.9	252	5-6
Gasoline from Petroleum I O.47 (Poland)	739.3	-	500	1.5	744.5	-	265	6
	739.4	21.2	530	1	744.5	21.1	270	6
Gasoline from Petroleum II, I.B.P. 35°C Main Point 50-30°	749.5	-	473	1	754.0	-	315	6-7
	749.5	14.55	500	0.5*	754.5	20.8	300	1
Petroleum from shale oil	750.3	-	411	1	754.0	-	308	5*
	750.3	11.95	404	1	754.5	20.8	295	2
Gasoline from shale oil	750.3	-	463	1	754.0	-	320	5
	750.3	11.95	470	1	754.5	23.4	308	3

\*Indistinct.

\*\*Irregular.

Table XIII (Cont.)  
Fatty and Mineral Oils

	A i r				O x y g e n			
	Bar. press. mm Hg	H <sub>2</sub> O content g/kg	Igni- tion point °C	Time lag sec.	Bar. press. mm Hg	H <sub>2</sub> O content g/kg	Igni- tion point °C	Time lag sec.
Crude naph- thoic acid	753.2	-	478	1	745.4	-	310	3-4
	753.0	23.45	484	1	745.4	21.05	320	3
Bustenari extract	752.0	-	571	1	740.2	-	287	3
	752.0	22.2	602	1	740.2	21.2	290	5
Paraffin, pressure distilled	751.5	-	494	1	747.2	-	287	2
	751.5	11.95	494	1	747.2	19.85	290	3
Gas Oil	757.0	-	336	1	740.8	-	270	3
	757.0	15.35	336	1	740.8	21.2	270	3

TABLE XIV

## Essential Oils

Eugenol	746.1	-	393	1	746.6	-	338	1
	746.0	23.7	406	2-3	746.6	19.9	340	2
Methyl- eugenol	746.2	-	425	3	747.8	-	390	2
	746.1	25.15	422	2-3	745.7	22.35	393	2
Safrol	752.5	-	500	1	739.7	-	445	3
	752.5	23.45	502	1	739.2	21.25	454	2
Isosafrol	-	-	650	0	748.5	-	457	3
	-	-	650	0	748.5	14.55	457	3

TABLE XV.

## M i x t u r e s

	Oxygen			
	Bar. press. mm Hg	H <sub>2</sub> O content g/kg	Igni- tion point °C	Time lag sec.
Benzoic acid in ethyl alcohol 1 : 2.44	758.8	-	515	4
	758.8	19.55	563	3
1 Vol. turpentine oil + 9 Vol. benzene	757.8	-	440	1
	757.8	22.0	435	3
4 Vol. turpentine oil + 6 Vol benzene	747.9	-	350	2
	-	-	-	-
8 Vol. turpentine oil + 2 Vol. benzene	758.0	-	280	1
	-	-	-	-
'Reichskraftstoff' I	755.1	-	500	3-5
	755.0	19.65	490	2
'Reichskraftstoff" II	755.0	-	510	4-6
	755.0	19.65	515	3-4

## (7) Ignition Points in Air and Oxygen of Substances Investigated

Arranged in Alphabetical Order\*

	Ignition points °C	
	Dry air	Dry oxygen
Acenaphthene	528	494
Acetaldehyde	185	140
Acetic acid	665	560
Acetic anhydride	585	432
Acetone	700**	568
Allyl alcohol	367	406
Amyl alcohol	409	300***
Amylene	590****	332
Aniline	770	530
Anthracene	605	540
Auto oil	430	260
Benzaldehyde	180	168
Benzene, c.p.	740	662
Benzene, tech.	730	577
Benzoic acid	710	590
Borneol	505	425
Bustenari extract	571	287
n-Butyl alcohol	450	385
tert-Butyl alcohol	-	500
Butyl toluene	574	520
Butyric anhydride	320	370
Camphor	515	388
Cetene	245	228
Cetyl benzene	385	230
Cinnamic acid	640	525
Crude oil, Pennsylvania	367	242
Cyclohexanol	530	325
Cyclopentadiene	-	414
Cylinder oil	417	320
Decane	463	202
Diamylene	445	312
Dinitrobenzene	510	508
Ethyl alcohol	558	425
Ethyl benzene	490	500
Ethyl benzoate	675	580

\*The values for ignition points in air above 620°C are taken from the work of J. Tausz and H. Koch.

\*\*Addition of 2-3 drops.

\*\*\*The amylenes were partially polymerized and oxidized.

\*\*\*\*Value given as 390°C in Table IX. - Tr.

	Ignition points °C	
	<u>Dry air</u>	<u>Dry oxygen</u>
Ethyl ether	343	178
Eugenol	393	338
Formaldehyde	478	425
Formic acid	650	-
Gas oil	336	270
Gasoline from petroleum	470-530	265-315
Gasoline from shale oil	463	320
Glycerine	500	414
Heptylic acid	602	260
Hexaethyl benzene	490	383
Hexane	487	268
Hydrocinnamic acid	612	500
Hydroquinone	635	558
Indene	650	484
Lauric acid	533	275
Linseed oil	463	285
Mannitol	475	400
Menthene	574	295
Mesitylene	720	610
Methyl alcohol	560	555
Methylcyclohexane	522	290
o-Methylcyclohexanol	574	336
m-Methylcyclohexanol	546	328
p-Methylcyclohexanol	577	366*
Methyl eugenol	425	390
Naphthalene	700	618
Naphthoic acid, crude	478	310
Nitrobenzene	510	510
Nonylic acid	391	250
Oxalic acid	725	618
Palmitic acid	425	245
Paraffin	388-414	243-258
Paraffin, pressure distilled	494	287
Petroleum	290-435	250-265
Petroleum from shale oil	411	308
Phenol, c.p.	715	574
Phenol, tech.	-	494
Pinene, c.p.	310	280
Pinene, tech.	300	278
n-Propyl alcohol	505	445
iso-Propyl alcohol	590	512
Propylaldehyde	280	260
Pseudocumene	710	533
Pyridine	685	587

\*Value given as 336°C in Table III - Tr.



	Ignition points °C	
	Dry air	Dry oxygen
Pyrocatechol	643	490
'Reichskraftstoff' I	-	500
'Reichskraftstoff' II	-	510
Retene	630	629
Sabinene	290	275
Safrol	500	445
iso-Safrol	650	457
Salicylaldehyde	372	262
Shale oils	354-435	272-290
Stearic acid	430	250
Stilbene	585	502
Sucrose	385	378
Tar oil from coal tar	-	518
Tetrahydronaphthalene	490	338
Toluene	810*	552
1.3.4-Trimethylcyclohexane	475	270
Trinitrophenol	360	435
Triphenyl benzene	670	515
Undecylenic acid	338	245
Valeraldehyde, c.p.	417	200
Valeraldehyde, oxidized	640	240
Valeric anhydride	320	365
Wood oil	430	357
Xylene, tech.	750**	540
p-Xylene	-	552

\*Addition of several drops.

\*\*Indefinite ignition.

### (8) Ignition Point Lowering of Benzene by Means of Turpentine Oil

It is known that the aromatic substances have a very high ignition point as compared with aliphatic substances. As we discovered, however, their ignition points are very much depressed by traces of impurities. Certainly this is the case only at ordinary pressure. As already mentioned, to this circumstance is to be attributed the fact that the true ignition

point of benzene was not yet known, since chemically pure (thiophene-free) benzene was evidently not used in the previous measurements. This has an ignition point of  $662^{\circ}\text{C}$ , whereas benzene with a very small content of thiophene has an ignition point of only  $577^{\circ}\text{C}$ .

Whereas pure benzene ignites very irregularly at the ignition point in the crucible, that is, it does not always ignite, even one drop of turpentine oil in 10 cc of benzene is sufficient to make the ignition regular. At the same time, it lowers the ignition point of benzene. On addition of turpentine oil to benzene, the following ignition points in dry oxygen are obtained:

Benzene, c.p.	$662^{\circ}\text{C}$
5 vol. benzene + 1 vol. turpentine oil	$435^{\circ}\text{C}$
6 vol. benzene + 4 vol. turpentine oil	$350^{\circ}\text{C}$
2 vol. benzene + 8 vol. turpentine oil	$280^{\circ}\text{C}$
Pure turpentine oil	$278^{\circ}\text{C}$

Thus, whereas the ignition point of benzene is lowered by  $227^{\circ}\text{C}$  on addition of 10% of turpentine oil, an addition of 20% of benzene to turpentine oil does not raise the ignition point appreciably.

## (9) Ignition Point Measurements on Shale Oil Fractions

Shale oils have a low ignition point. In order to determine the ignition point of individual fractions, 200 cc of Wurttemberg shale oil was distilled and the fractions coming over by 10° intervals were collected

Boiling interval of fraction °C	Dry Air			Dry Oxygen		
	Bar. press. mm Hg	Igni- tion point °C	Time lag sec.	Bar. press. mm Hg	Igni- tion point °C	Time lag sec.
200	756.8	445	1-2	758.0	300	3-4
200--- 210	"	450	1	758.0	305	3-4
210 - 220	"	460	2	-	-	-
220 - 230	"	465	1-2	758.0	308	3-4
230 - 240	"	468	1-2	-	-	-
240 - 250	"	470	1	758.0	305	4-5
250 - 260	"	457	1	"	300	4
260 - 270	"	475	1	"	302	4-5
270 - 280	"	468	1	"	301	4-5
280 - 290	"	473	1	"	302	4-5
290 - 300	"	430	1	758.1	288	4-5
300 - 310	"	447	1	758.0	302	4-5
310 - 320	"	457	1	785.1	302	5-6
320 - 330	756.7	473	1-2	758.1	305	4-5
330 - 340	"	470	1-2	758.1	305	4-5
340 - 350	"	468	1-2	758.0	305	4-2

Boiling interval of fraction °C	Dry Air			Dry Oxygen		
	Bar. press. mm Hg	Igni- tion point °C	Time lag sec.	Bar. press. mm Hg	Igni- tion point °C	Time lag sec.
350 - 360	756.7	480	1-2	757.8	308	4-5
Over 360	755.6	500	3	758.0	322	6-7
Crude shale oil	"	445	2	758.0	292	3-4
Shale oil freed from gasoline	"	457	2-3	758.0	305	5-6

The table shows that the ignition point is independent of the boiling point of the fraction and that the ignition point of the crude product is approximately that of the fraction which ignites at the lowest temperature. The shale oil, freed from gasoline, was obtained by distilling off from the crude shale oil that part boiling below 200°C. The great difference between the ignition points of the fractions 280-290°C and 290-300°C is striking. The independence of the ignition point on the boiling point of the fraction is further demonstrated by the fact that ability to vaporize is without effect on the ignition point. (See p. 8 (3) of this paper, also General Part, Technical Memorandum No. 483, Part I.)

Ignition Points of Shale Oil Fractions and  
Their Physical and Chemical Constants

Boiling range °C	$n_D^{18}$	Sp.gr. 20/15	Hg No.	Pic- ric acid No.	Dry air			Dry oxygen		
					Bar press. mm Hg	Igni- tion point °C	Time lag sec.	Bar. press. mm Hg	Igni- tion point °C	Time lag sec.
39-44	1.3853	0.6805	1006	-	746.8	510*	1	744.8	205*	2
55-60	1.3883	0.7020	728	7.489	747.0	468	1	745.5	185*	2
60-64	1.3910	0.6978	614	4.297	747.2	463	1	746.1	215	2-3
64-66	1.3938	0.7015	603	3.318	746.0	409	1	746.2	230*	2
66-68	1.3969	0.7035	632	1.436	747.1	362*	1	746.0	232	1
68-70	1.4030	0.7155	606	1.237	746.1	457	1	746.1	225	2
70-71	1.4092	0.7278	602	-	746.0	440	1	746.1	202	2-3
71-72	1.4132	0.7278	638	-	746.1	440	1	746.1	192	2
72-74	1.4195	0.7452	639	1.958	746.0	406	1	746.1	200	2-3
74-76	1.4241	0.7582	663	4.003	746.2	484	1	746.2	245	2-3
76-78	1.4257	0.7629	697	2.945	746.2	468	1	746.2	202	0.5-1
78-80	1.4288	0.7640	704	1.212	746.1	520	1	746.2	310	2
80-82	1.425	0.7615	721	2.131	746.1	484	1	746.2	273	4
82-84	1.423	0.7604	659	4.055	746.0	409**	1	752.8	205	2
84-86	1.421	0.7484	753	0.529	751.8	420	1	752.8	285	2
86-88	1.416	0.7464	841	-	751.3	404	1	752.8	265	2
88-90	1.413	0.7400	879	-	751.8	420**	1	752.8	275	1-2
90-92	1.411	0.7372	851	-	751.8	383	1	752.8	198	2-3
92-94	1.410	0.7346	826	0.528	751.5	375	1	752.8	310	3-4
94-96	1.412	0.7357	879	0.371	751.4	350	1	752.7	166	1
96-98	1.413	0.7408	730	0.409	751.8	365	1	752.8	195	1
98-100	1.418	0.7525	543	0.408	756.7	340	1	752.7	262	4
100-102	1.426	0.7672	539	0.535	765.0	409	1	752.7	193	1-2
102-104	1.431	0.7803	530	0.568	756.8	435	1	752.6	152	2
104-106	1.438	0.7920	529	0.469	756.9	450	1	751.3	198	1
106-108	1.441	0.8036	528	2.147	756.8	435	1	751.6	215	2
108-110	1.446	0.8085	531	0.983	756.8	484	1	751.6	225	1-2
112-114	1.444	0.8005	508	0.664	757.1	463	1	751.5	243	1
114-116	1.438	0.7914	567	0.428	757.2	440	1	751.3	210	2
116-118	1.432	0.7829	521	0.912	757.1	372	1	751.5	255	1
118-120	1.429	0.7721	563	0.576	757.2	375	1	751.3	265	6

\*Uncertain

\*\*Irregular

There were at our disposal fractions of Württemberg shale oil which were obtained by repeated accurate fractionation by 2° intervals and had been investigated chemically.\* In order to be able to ascertain whether any connection existed between the ignition point and the content of aromatic and olefinic compounds, the ignition points in air and oxygen were measured and are given in the above table together with the physical and chemical constants concerned. Besides the boiling range of the fractions, their specific gravity and index of refraction, we quote the mercury numbers\*\* as a measure of the degree of unsaturation and the picric acid number\*\*\* as a measure of the aromatic hydrocarbon content.

The change in the ignition point can be detected more clearly from the graphical representation in Figure 3 than from the table, and in particular, it is noticed that the different trends of the ignition points in air and oxygen are very evident. The maxima of the ignition points in air lie at those fractions with a boiling point of benzene (80°C) and of toluene (110°C). The picric acid number certainly does not show the expected maximum at 80°C. The very different trends of the ignition point in air and oxygen with increasing boiling point of the fractions is striking, and since pure oxygen has the same partial pressure as air has at 5 atmospheres, an estimate can be made as to differences in the change of ignition point with increasing pressure.

---

\*Dissertation of Neubronner from the Petroleum Research Laboratory of the Technical High School of Karlsruhe, Stuttgart, 1921.

\*\*J. Tausz, Petroleum, 13, 649 (1918).

\*\*\*Tausz and Schnabel, Chem. Ztg., 1919, p.726.

With this shale oil, the appearance of two and sometimes as many as three ignition points frequently occurred. Since these values were not very reproducible, they were omitted for the time in the publication of these results.

## II. Measurement of the Ignition Point Under Pressure

### (1) The Necessity for Measuring Ignition Points Under Pressure, in Particular for the Evaluation of Fuel Oil Mixtures

It has been already proved in the General Part (Technical Memorandum No. 483, Part I) that the change in the ignition point with pressure is very variable. So numerous are the reactions which occur at ordinary pressure with fuels before ignition takes place, that its complexity is raised to a still higher power if the reactions on ignition under pressure are taken into consideration. On inspection of the curves in Figure 3 for shale oil distillates, it is immediately recognized that the assumption of Alt\* does not prove to be correct, according to whom the ratio of the absolute ignition temperatures under pressure and at ordinary pressure is a constant for the various fuel oils. The ignition points in air and pure oxygen have entirely different trends. Frequently the difference between successive fractions is in itself extremely variable. Thus the difference for the fraction 92-94°C is only 65°C, while for the fraction 90-92°C immediately preceding and that 94-96°C immediately following, it is 184-185°C. This is an example with one and the

---

\*Zeitschrift des Vereines deutscher Ingenieure, 67, 686 (1923).

same product. Naturally the diversity of the ratio of the ignition points with different fuel oils is much greater. Substances are even known with which the ignition point in oxygen is higher than in air and with which the ignition point increases appreciably with increasing partial pressure of hydrogen.

Hence it results that measurement of the ignition point at ordinary pressure is not a definite criterion for the usefulness of a fuel oil in the Diesel engine, which has frequently been assumed. It is particularly worthless for evaluating the improvement by blending with such unsuitable fuels as coal tar. As we shall see later, the ignition point of coal tar oil, for example, is very much lowered by the addition of 10 to 20% of shale oil and in fact, at 5 atmospheres pressure, where the partial pressure of oxygen is the same as that of the pure gas, the ignition point lowering is very large. But on increasing the pressure further, it is less and already at approximately 10 atmospheres, the mixture ignites at a higher temperature than the pure coal tar oil. The same phenomenon occurs with mixtures of lignite tar oil (See Figure 8). We see further that a blending, which lowers the ignition point in oxygen, can have the opposite effect in the engine, that is, at high pressure, and can even raise the ignition point.

Constam and Schlapfer\* were the first, as far as is known, to point out that ignition point measurements at ordinary pres-

---

\*Zeitschrift des Vereines deutscher Ingenieure, 57, 1717 (1913).



sure could only detect the differences which the various classes of fuel oils show and which are determined by their chemical nature. That the circumstances on ignition in the Diesel engine are entirely different and in fact much more complicated than at ordinary pressure, results from the following phenomenon. With ignition at ordinary pressure, the means of distribution, the degree of vaporization, the fineness of atomization and the homogeneity of the oxygen mixture have no appreciable effect upon the temperature of ignition, but affect rather the completeness of combustion and the velocity of propagation of the explosion (See p. 43, Part I, Technical Memorandum No. 483, and p. 10 of this paper). This results also from our work with the apparatus shown in Figures 1 and 2, in which the same ignition points were obtained in air even with different distribution of the fuel. Therefore, in the measurement of the ignition point at ordinary pressure, that is, in the open crucible, it is not necessary, as Holm assumed, to create through international agreement, an accurately established apparatus with a prescribed procedure, in order to make values by different laboratories and observers comparable. Rather is the ignition point at ordinary pressure a significant constant fixed for each substance, which on measurement in any apparatus whatever, gives the same value provided catalytic effects are eliminated, provided the temperature in the ignition chamber is uniform and provided air or oxygen<sup>is</sup> introduced in quantities which fall within the explosive limits. Thus the ignition point tester of the Krupps

firm, which had entirely different dimensions, gave the same value for the ignition point as did our apparatus shown in Figure 1, when it was possible to introduce the correct quantity of fuel and the corresponding amount of air was accurately obtained. Where it is not possible to fulfill these conditions, the ignition point has not another value, but its measurement is merely more uncertain.

However, it is much more difficult to obtain the same value with differences in apparatus in the case of measurements under pressure. This is the case since the ignition depends upon the previous formation of primary products and, for example, the course of thermal decomposition under conditions of varying pressure (Research B, p. 60, table of experimental results) (Figs. 8-12) must be different than with constant pressure (Research A, p. 52, table of experimental results) (Fig. 5). Even as the primary phase of combustion proceeds differently at various pressures, with the result that no definite conclusions can be drawn from ignition point measurements at ordinary pressure as to ignition in the engine, so is also the primary phase of the combustion under pressure dependent upon the changes in pressure during these reactions. Therefore the ignition point of a substance is not fixed at a definite temperature for the final compression pressure, but is dependent upon all previous pressures and corresponding temperatures.

In order to make ignition point measurements under pressure, two simple types of apparatus were constructed. With the first type, measurements of the ignition point were made at constant pressure, while with the second type, the fuel was sprayed into the crucible by means of air under pressure, similar to the process in the Diesel engine.

(2) Experiments without Atomization of the Fuel - Research A.

In a round iron block (Fig. 4), a crucible-shaped hole A of 25 cc capacity was drilled out, and by means of a coupling B, an introduction tube C was screwed on and was closed at the top with a cap D. In the lower part of the introduction tube, just above the coupling, connections E and F were welded on which led respectively to the air inlet valve G which was connected to the intermediate air container O, and to the manometer H and the expansion valve J. At the upper end of the introduction tube C, a stuffing box was placed through which extended a gas-tight movable spindle, the end of which projected into the introduction tube and was bent into the form of a wire hook M for holding a small glass bulb filled with the fuel. The hook was so bent that it lay in a position perpendicular to the wall of the introduction tube on turning the handle of the spindle and thus almost exactly reproduced the cross section of the introduction tube. The small glass bulb could fall freely. The introduction tube was cooled with water flowing through the cooling jacket L,

in order to obtain as low a temperature as possible in the upper part. The iron block had a small shaft immediately under the crucible-shaped chamber for the introduction of the thermocouple. The lower part of the apparatus including the coupling was enclosed in a sheet metal cylinder provided with openings for gas and air and for the removal of the products of combustion from the gas burner. In addition, there was an opening for the introduction of the thermocouple wires and a peephole for observing the gas flame. The inside of the cylinder and the lower side of the cover was covered with thick asbestos paper for heat insulation. When working at higher temperatures, value is to be placed upon the most careful heat insulation in order that too rapid a decrease in temperature of the crucible block may be avoided. This would certainly lead to erroneous results, since in that case the temperature distribution in the ignition block is not uniform.

The experimental procedure will be described below, illustrated by an example. If the ignition point of lignite tar heating oil is to be measured at an absolute pressure of 5 atmospheres, the cooling of the introduction tube L is started and the ignition block is brought to a temperature of 350°C by means of a gas flame. It would then be turned off and care taken that the temperature of the ignition block fell about 3-5 °C per minute. The cap D would be unscrewed, the lignite tar heating oil enclosed in a small glass bulb would be placed on the ring

M adjusted to a level position, and the cap would again be replaced.

The apparatus would be filled through the valve G with air up to an absolute pressure of 5 atmospheres from the intermediate compressed air container, and after closing the valve about one minute would be allowed to elapse in order to permit the compressed air in the crucible to be heated completely. Then by turning the wire hook M into a vertical position, the small glass bulb containing the substance would be allowed to fall into the crucible. If an explosion occurred, this was indicated by a rapid but powerful deflection of the manometer pointer. After withdrawing the air and the gaseous products of combustion from the apparatus, the cap would be removed and the remainder of the gases would be blown out of the crucible by means of a strong current of air. At somewhat lower temperature, but at the same absolute pressure of 5 atmospheres, a further experiment with the same substance would be made, until ignition would no longer take place, and the lowest ignition temperature at 5 atmospheres would be reached, which for the present example was 290°C.

The contents of the small glass bulb amounted to approximately 0.25 cc. Originally the bulb was sealed off after filling with the substance, resulting in a long, finely drawn out point. However, it developed that in about 30% of the experiments tried, neither the point broke nor did the bulbs themselves break from the internal pressure resulting from the heating. In consequence,

therefore, the bulbs were not sealed thereafter, but a short piece of open glass tubing about 3 mm long was left on them. When a bulb filled with material fell into the heated crucible, the material was expelled by its own expansion as well as by the expansion of the small air bubble which must be present in the bulb. The bulbs were made from soft glass tubing, 2.5 mm outside diameter and 1 mm inside diameter. After blowing a bulb up to its volume of about 0.25 cc, the glass tube was broken off at a point about 3 mm from the bulb.

With fluid substances, the introduction of the material was effected with the help of a funnel, which was drawn down to a fine point. With plastic substances such as paraffin, the following method was adopted. The substance to be introduced was heated in a wide test tube until it was sufficiently fluid. During the heating, decomposition should not be permitted to occur. Then a number of small bulbs were inserted and the test tube was evacuated. If care was taken that all of the bulbs dipped into the liquid, they were filled with the substance when the vacuum was suddenly reduced. After cooling, the bulbs were ready for use in the experiments. In order to make certain that an abundant flow of material out of the bulbs occurs, it is necessary to have a small air bubble inside each.

In the experiments with low boiling substances such as gasoline, benzene petroleum, and so on, cooling of the introduction tube is necessary in order that the material may not be expelled

by the heat before the bulb falls into the crucible, thereby throwing doubt on the certainty of the experiment. With the apparatus used and with the utilization of small glass bulbs of 0.25 cc capacity in order to protect against the possibility of uncertainty in the ignition point measurements which occurs with bulbs of smaller capacity, the following observations were made. If an experiment has been conducted in the manner described above and if the first ignition has occurred, then if the burnt gases are drawn off but if the apparatus is not swept out, however, but is again filled to the same pressure with air, a further ignition occurs and in fact, this happens until the substance is used up, since each time a portion of the material comes out of the bulb. The ignition points agree completely with those determined first and it affords many control measurements during an experiment, so that the determination of the ignition point is very accurate. After each experiment, the ignition block must be opened up by removing the introduction tube in order to remove the small glass bulb.

Investigations were made on technical benzene, a commercial product 95% pure; on gasoline with a boiling range of 35-120°C and with the main portion coming over between 50-60°C; on kerosene with a boiling range of 120-270°C and with the main fraction at 180-240°C; on paraffin with a drop point of 49.5°C according to the method of Ubbelohde; on gas oil of specific gravity 0.864 and having the following distillation characteristics, determined

by the standard Engler distillation:

Original amount	100 grams		
Boiling range °C	cc Distillate or Vol. %		
159 - 175	0.5	.43	.43
175 - 200	0.5	.43	.86
200 - 225	4.0		4.3
225 - 250	13.0		15.6
250 - 275	28.0		39.7
275 - 300	25.5		77.8
300 - 325	19.5		77.8
325 - 350	15.0		90.7
Residue 9.5 grams			

*accumulated*

on refined Argentine machine oil of viscosity 4.5E<sup>0</sup> (50°C) and a flash point of about 200°C; on American cylinder oil; on lignite tar heating oil from producer tar of the B.A.S.F. with specific gravity of 0.996, and distillation characteristics according to the standard Engler method as follows:



Original amount	100 grams	
Boiling range °C	cc Distillate or Vol. %	Vol. % accumulated
*170 - 125	0.5	.5
125 - 150	0.5	1.0
150 - 175	0.5	1.5
175 - 200	0.2	1.7
200 - 225	0.3	2.0
225 - 250	3.5	5.5
250 - 275	11.3	16.7
*175 - 300	16.3	33.0
300 - 325	32.5	65.5
325 - 350	16.2	81.7

Residue 23.5 grams

on coal tar oil; on Diesel engine oil of the Mining Joint Stock Company of Lothringen, of which the main fraction used was from 265 - 310°C; on Württemberg shale oil of specific gravity 0.984 and distillation characteristics according to the standard Engler method as follows:

---

\*These figures are obviously typographical errors. - Tr.

Original amount Boiling range °C	100 grams cc Distillate or Vol. %
135 - 150	1.0      1.98
150 - 175	2.0      2.95
175 - 200	3.4      6.30
200 - 225	7.2      13.4
225 - 250	15.4      28.5
250 - 275	15.0      43.3
275 - 300	18.0      61.5
300 - 325	16.0      77.5

Residue 27.7 grams.

These pressure Series A experiments were intended mainly to provide a comparison of the ignition points determined in oxygen at ordinary pressure with those in air at 5 atmospheres, at which the partial pressure of the oxygen is equal to that of the pure gas at ordinary pressure. In the following table, the ignition points determined in the first ignition block with oxygen are grouped with those determined in air at 5 atmospheres pressure in the apparatus described above.

	Air at 5 atm., abs. °C	Oxygen at ordinary pressure °C
1. Gasoline	270	240
2. Kerosene	310	270
3. Paraffin	318	240
4. Shale oil	375	288
5. Lignite tar heating oil	305	300
6. Coal tar oil	555	528

As seen from the table, the ignition points are not the same under the two conditions, although the partial pressure of oxygen is the same in both cases. The difference is greatest with substances which easily undergo thermal decomposition and form unsaturated compounds, such as the paraffins, or which originally contain unsaturated compounds, such as shale oil. With fuels which consist of different members of the same homologous series, such as gasoline, kerosene and paraffin, the difference increases with the size of the molecules. With gasoline which boils without decomposition and with which decomposition before ignition is least, the ignition points are similar.

We know that on cracking under pressure the quantities of resulting unsaturated cleavage products are very appreciably decreased and it is the unsaturated substances which most readily take up oxygen and which ignite at the lowest temperature. Therefore, although the reaction with oxygen must be the same on ac-

count of identical partial pressures, nevertheless the ignition points differ since the quantities of unsaturated cleavage products formed before ignition are different. Thus the ignition points in oxygen at ordinary pressure are frequently lower and never higher than in air at 5 atmospheres.

The ignition points at various pressures of the substances described, obtained with the experimental apparatus A, are collected in the following table. The graphical representation in Figure 5 contains the curves of the ignition points with increasing pressure.

The ignition points are very different from those of Series B, in which the same substances were investigated, but in which the initial phase of combustion occurred under a condition of varying pressure, since the oil was sprayed in.

## Experimental Results of Series A (Fig. 5)

Paraffin		Gasoline	
Atm., abs.	Ignition point °C.	Atm., abs.	Ignition point °C.
3.0	400	2.2	375
3.5	375	2.5	350
4.0	355	3.0	322
6.0	300	3.5	300
7.0	285	4.0	295
7.5	275	5.0	275
8.0	272	6.0	263
10.0	250	8.0	245
12.0	233	10.0	232

Kerosene		Benzene	
2.0	440	8.5	655
2.5	400	9.0	635
3.0	375	10.0	600
4.0	330	11.0	580
5.0	305	12.0	456*
6.0	282	13.0	545
8.0	255		
10.0	235		
11.0	225		

\*Probably a typographical error. - Tr.

Shale Oil		Lignite Tar Heating Oil	
Atm., abs.	Ignition point °C	Atm., abs.	Ignition point °C
4.0	412	3.0	370
5.0	375	4.0	325
6.0	360	5.0	310
7.0	335	6.0	285
8.0	315	8.0	265
9.0	305	9.0	250
10.0	300	10.0	245
11.0	285	12.0	232

Coal Tar Oil	
Atm., abs.	Ignition point °C
4.0	625
4.5	580
5.0	565
6.0	520
8.0	475
8.5	462
9.0	455
10.0	440
11.5	425

## (3) Experiments with Atomization of the Fuel - Series B

The apparatus constructed for this work yielded good ignition points and permitted rapid operation, so that it was easy to obtain relatively comparable values. The results of this series of experiments agree with those of Rieppel, which were carried out directly in the Diesel engine.

For the measurement of the ignition point, oil absorbed on a fine wire gauze was blown by means of compressed air into a heated cylindrical chamber of 10 cc capacity. The construction is evident from Figures 6 and 7. In an iron block A, various connections were made in a suitable manner. One of these led to the injection tube B, into which was inserted a roll of wire gauze C, and closed tightly at the top by means of the cap nut D. In order that the material being investigated did not vaporize or decompose during the time between the introduction of wire gauze roll and the beginning of the experiment, the injection tube was provided with a water jacket E, which cooled it during the measurements by means of flowing tap water. A small ignition block F of 10 cc capacity was screwed into the iron block A underneath B. The bottom of F was protected from the direct effect of the heating flame S, by means of an asbestos cap, and contained a shaft in the lower part for the admission of the thermocouple, the wires from which ran to a millivoltmeter. The lower part of the injection tube was pro-

vided with a nozzle H so that the material could be blown completely into the ignition block and not remain partially in the space between the injection tube and the ignition block.

The compressed air was warmed by passage through a shaft inside of A and led into B above C through the inlet tube J. In the inlet tube, there was an opening for the valve K, whereby the gases could either be blown out into the air or could be collected for analysis, depending upon the result of the experiment. A manometer L was connected to the inside of the ignition block by means of tubing and a shaft in the iron block, with which the occurrence of ignition was detected. The compressed air was drawn from the intermediate container M which was chosen of such a size that on filling the ignition apparatus with compressed air, the pressure in it only fell about 0.2-0.3 atm. The pressure in the intermediate container was measured by means of the manometer N, and it was filled with compressed air from the container P. An inlet valve O was placed between the intermediate container and the ignition point tester, which on rotating slightly opened sufficiently wide to fill the ignition point apparatus with compressed air almost instantaneously. In order to obtain uniform heat distribution in the iron block and the ignition block, the whole ignition point apparatus was placed inside of an iron box R, the inside of which was covered with heavy asbestos paper in order to minimize heat radiation to the outside as much as possible. Also the upper part of



the box including the ignition point tester was insulated with asbestos, R was provided with a chimney Q, through which the burnt gases from the burner S could escape, and it was fitted with a damper T.

The intermediate container M and the ignition point apparatus were connected through the tube U while the experiment was being conducted, so that a ball valve V was introduced which acted as a recoil valve when ignition occurred. In this way pollution in the intermediate container on combustion was avoided, which would under the circumstances lead to erroneous results. Also on incomplete ignition, combustible gas might pass back into the intermediate container and form an explosive gas mixture with the compressed air.

The temperature measurements on calibration of the thermocouple were made as follows. The nozzle H was first unscrewed from the injection tube, heating of the ignition point apparatus was discontinued after once heated, and the chimney was closed. The fall in temperature amounted to about  $3^{\circ}$  per minute. By means of a thermometer stuck through the injection tube down to the bottom of the ignition block, the temperature decrease was measured and at the same time, the reading of the millivoltmeter was noted. Since the emergent stem of the mercury thermometer was exposed only to the heat from the cooling water used in cooling the injection tube which was at a temperature of about  $12-15^{\circ}\text{C}$ , the stem correction of the mercury thermometer must be

considered in the calibration. The deviation of the temperature curve of the thermocouple in the ignition block from that indicated by the thermometer was small. By making measurements, the temperature in the upper third of the ignition block at the above-mentioned rate of cooling of  $3^{\circ}$  per minute was found to be only about  $2-3^{\circ}\text{C}$  less than the temperature at the bottom of the ignition block which was measured with the thermocouple. If more rapid cooling occurred, then the temperature difference between the upper third and the bottom of the block increased up to about  $10^{\circ}$ .

It was proved as follows that sufficient heating of the compressed air was obtained while being introduced. The apparatus was heated up to about  $500^{\circ}\text{C}$ , after which the heating was discontinued and the chimney closed by means of the damper T. While the injection tube was cooling, a thermometer was placed in it down to the opening of the introduction tube J. The mercury bulb was insulated with asbestos except the side facing the tube J, so as not to cool the mercury by the cold walls of the injection tube. A moderately strong current of air was then blown through the iron block and the tube leading into the injection tube, and at the same time, the temperature in the ignition block and that of the flowing air were measured. It resulted that when the ignition block was at a temperature of  $400^{\circ}\text{C}$ , the air flowing in had a temperature  $10-12^{\circ}\text{C}$  lower. At  $200^{\circ}\text{C}$  in the ignition block, the difference was greater and the

temperature of the air was about  $15^{\circ}\text{C}$  lower than that measured in the ignition block. The preheating was thus entirely sufficient.

The experimental procedure, exemplified by the measurement of the ignition point temperature of coal tar oil at 20 atmospheres absolute, was as follows. The intermediate compressed air container M was filled to an absolute pressure of 20.2 atm. with compressed air from the reservoir P. The ignition point apparatus was heated to  $450^{\circ}\text{C}$  and at the same time, the injection tube B was cooled with running water. Heating was then discontinued and the chimney closed by means of the damper T, after which one waited until a slow cooling of the ignition point apparatus occurred. After the cap nut D was unscrewed, about 1-2 cc of coal tar oil was added by means of a pipette to the roll of wire gauze already installed. The injection tube was closed with the cap nut D and the apparatus was filled with compressed air at an absolute pressure of 20.2 atmospheres by a short turn of the valve O. This sprayed the oil held by the roll of wire gauze into the ignition crucible.

If ignition occurred, it was detected by a rapid intermittent deflection of the pointer on the manometer L. Thereupon the products of combustion were allowed to escape into the air by opening the valve K, the cap nut D was removed and after drawing out the roll of wire gauze, the ignition block and the injection tube were blown out with a strong current of air in

order to remove the last traces of the combustion products. When the same experiment was repeated at  $425^{\circ}\text{C}$ , ignition occurred. With the next experiment at  $400^{\circ}\text{C}$ , ignition no longer took place. Then further experiments were conducted in the temperature range from  $400\text{--}425^{\circ}\text{C}$  until the final ignition point was obtained at  $418^{\circ}\text{C}$ .

In the same manner, this substance was investigated at other pressures. If ignition occurred and the products of combustion were allowed to escape into the air after the determination of the temperature and pressure, but if the apparatus was not opened up and blown out, then on filling the apparatus again with compressed air after closing the valve K, it was very unusual at the same temperature and pressure for ignition to occur again. This is obvious from the fact that the quantity of oil introduced is so measured that after the first occurrence of ignition, sufficient oil does not remain behind to initiate a further ignition of such force as to make it observable from a deflection of the manometer. Thus in this case many control measurements during the one experiment are not possible, in contrast to the case with the first series (A) under pressure, in which a fresh quantity of oil always was expelled from the small glass bulb used in those experiments.

The first experiments were made without the nozzle H, but the values obtained deviated so much from one another that a

change in the apparatus had to be made. On blowing the oil in without the nozzle, a greater portion of it remained in the space between the injection tube and the ignition block. It is to be assumed that on account of blowing through the roll of wire gauze, the oil did not fall in the finest state of subdivision into the ignition block but for the most part as drops. After the insertion of the nozzle H, scattering of the experimental values ceased and the same value was always obtained on repetition of the experiment. The ignition block and the nozzle must be removed after a series of experiments in order to remove the carbon particles, resulting from incomplete combustion on ignition, which occasionally adhere firmly to the walls.

Experimental Results of Series B (Figs. 8-12)

Paraffin		Gasoline	
Atm., abs.	Ignition point °C	Atm., abs.	Ignition point °C
2.6	375	3.0	425
3.5	350	3.8	402
4.0	330	4.4	380
5.4	302	4.8	370
7.0	280	6.0	345
8.8	260	7.2	332
10.8	248	8.0	320
11.4	240	9.2	315
12.5	228	11.0	308
		13.2	287
		15.5	283
		19.0	277
		20.4	272
		23.0	270
		33.0	260

Kerosene		Benzene	
Atm., abs.	Ignition point °C	Atm., abs.	Ignition point °C
3.6	420	7.5	657
4.0	412	8.0	642
4.2	395	8.4	630
5.5	362	9.0	620
6.0	325	9.4	587
6.8	318	11.0	570
7.2	302	12.0	550
8.5	275	13.5	537
10.5	252	15.0	525
13.0	232	16.8	515
14.3	222	18.4	507
16.0	220	20.0	495
17.4	215	22.0	490
20.6	210	25.0	483
23.0	205	26.0	477
27.0	200	30.0	468

Machine oil		Cylinder oil	
Atm., abs.	Ignition point °C	Atm., abs.	Ignition point °C
1.2	480	2.8	507
2.2	443	3.0	498
3.4	400	3.4	485
5.0	375	4.2	462
5.8	365	5.0	435
7.0	360	5.6	430
8.4	335	6.4	420
10.0	320	7.2	400
11.2	307	7.8	397
13.0	302	10.0	372
15.0	287	12.0	357
		15.0	342
		20.0	320
		25.0	312
		30.0	300

Lignite tar heating oil		Shale oil	
Atm., abs.	Ignition point °C	Atm., abs.	Ignition point °C
2.0	415	2.3	400
3.0	400	2.5	375
3.4	375	3.0	357
4.0	360	3.6	350
5.0	350	4.0	330
7.0	320	5.0	312
8.0	300	6.0	305
10.0	280	7.4	237*
12.0	270	9.0	275
14.0	260	10.0	263
16.0	240	11.0	250
17.0	232	14.0	232
21.0	225	15.0	225
26.0	205	16.0	222
		18.0	215
		19.0	212
		24.0	200

Coal tar oil		Gas oil	
Atm., abs.	Ignition point °C	Atm., abs.	Ignition point °C
6.0	650	3.2	400
6.4	625	3.3	387
7.0	600	3.8	375
8.0	575	4.0	350
9.0	550	4.2	337
10.0	525	4.7	325
11.0	518	5.8	307
12.0	495	7.0	280
13.0	487	8.0	270
14.0	475	9.2	262
15.0	458	11.0	257
16.0	450	12.0	248
18.0	437	13.0	245
20.0	418	16.0	230
23.0	398	18.0	225
26.0	385	20.0	222
23.0*	360	22.0	220
		24.0	215
		28.0	205
		15.0	242

\*Probably typographical errors. - Tr.

10% Lignite Tar heating oil in coal tar oil		30% Lignite Tar heating oil in coal tar oil		50% Lignite Tar heating oil in coal tar oil	
Atm., abs.	°C	Atm., abs.	°C	Atm., abs.	°C
8.0	550	5.0	602	4.0	590
9.2	537	5.8	580	4.6	577
10.0	522	6.6	568	5.2	463*
11.0	502	7.3	555	5.6	535
12.0	493	8.0	540	6.4	523
13.2	480	8.6	527	7.0	503
14.0	475	10.0	503	7.7	495
14.0*	463	11.0	490	8.6	475
16.0	455	12.0	482	9.0	462
16.6	445	13.0	475	10.0	450
18.0	440	14.0	468	11.0	445
19.0	435	15.0	463	11.4	440
20.0	430	16.0	452	13.0	415
21.5	412	17.0	442	14.0	403
22.5	405	18.0	438	16.6	387
26.0	390	22.0	418	16.0	400
28.0	377	24.0	410	18.0	375
31.0	370	26.0	398	20.0	368
34.0	357	26.6	395	21.0	363
		28.2	390	22.6	357
		31.0	375	23.0	350
		33.0	371	25.0	340
				28.0	330
				33.0	320
				30.0	327

\*Probably typographical errors. - Tr.



10% Shale Oil in coal tar oil		20% Shale Oil in coal tar oil	
Atm., abs.	°C	Atm., abs.	°C
8.0	605	4.0	610
9.0	575	5.0	590
10.4	550	6.0	585
12.0	520	7.0	575
13.0	515	8.0	562
14.0	500	10.0	550
16.0	480	11.0	540
18.0	468	12.0	537
20.0	460	14.0	525
22.0	443	15.0	512
24.0	433	17.0	500
27.0	415	21.0	480
31.0	397	23.0	470
34.0	388	26.0	450
		31.0	425

30% Shale Oil in coal tar oil		50% Shale Oil in coal tar oil	
Atm., abs.	°C	Atm., abs.	°C
5.0	525	4.0	510
6.0	510	4.4	487
7.0	500	5.0	475
7.2	495	6.0	440
8.0	487	8.0	410
10.0	463	8.5	407
13.0	450	9.2	400
15.0	433	10.4	387
15.4	427	11.0	380
18.0	412	12.0	375
20.0	402	15.0	357
23.0	387	16.0	350
24.0	385	19.0	333
26.0	380	22.0	325
30.0	375	24.0	320
33.0	365	20.0*	312
		32.0	300

\*Probably typographical error. - Tr.

The results of the pressure experiments show clearly how differently the same increase in pressure affects the ignitibility of the substances. Whereas increase in pressure caused a marked lowering of the ignition point temperature of paraffin, this is only the case with gasoline up to 6 atmospheres pressure after which further increase in pressure only depresses the ignition point slightly (steeper part of the curve, Fig. 10).

Kerosene lies in between gasoline and paraffin, while lignite tar heating oil shows a similar curve to that of paraffin on account of the large content of paraffin hydrocarbons. With petroleum, lignite tar heating oil, gasoline and paraffin among others, which for the most part are composed of aliphatic hydrocarbons or contain large quantities of them, the ignition points change very little with increasing pressure above 10 atmospheres. Shale oil behaves similarly on account of its large content of paraffin hydrocarbons. The curve for machine oil is particularly flat. Cylinder oil has naturally a high ignition point and gives a steep curve.

Whereas the experiments already made by us in Series A up to 10 atmospheres with oils containing aliphatic hydrocarbons give us also a picture of the trend of higher pressures, this is not the case with coal tar oil, with which experiments must be made at every higher pressure. Such experiments could only be carried out with apparatus B, with which it is possible to work up to 100 atmospheres. The gas oil used serves as an igni-

tion-inducing oil in the Diesel engine. Its ignition points indicate a very favorable trend as far as 10 atmospheres but above that it ignites at proportionately lower temperatures and with the various final compression pressures in the engine, the ignition points only differ by about  $40^{\circ}\text{C}$ . With cylinder oil, and to a lesser extent with machine oil, which are used as the main components of the lubricant for Diesel engines, the ignition points lie higher.

Whereas an appreciable lowering of the ignition point of coal tar oil occurs on measurement at ordinary pressure when a small amount of shale or lignite tar oils are added, the mixtures show a higher ignition point at high pressure than that of pure coal tar oil, as is evident from the tables or from Figure 12.

The results agree with the experiments of Rieppel on mixtures in the engine itself in so far as it is shown there that addition up to 50% of an easily igniting oil does not raise the slight utility of coal tar oil. Only those mixtures which contain more than 50% of an easily igniting oil, ignite sufficiently low and are good for use.

The apparatus used in experimental Series B appears to be suitable for more accurate evaluation of fuels and their mixtures with regard to their utilization in the Diesel engine.

Translation by Oscar C. Bridgeman,  
Bureau of Standards.

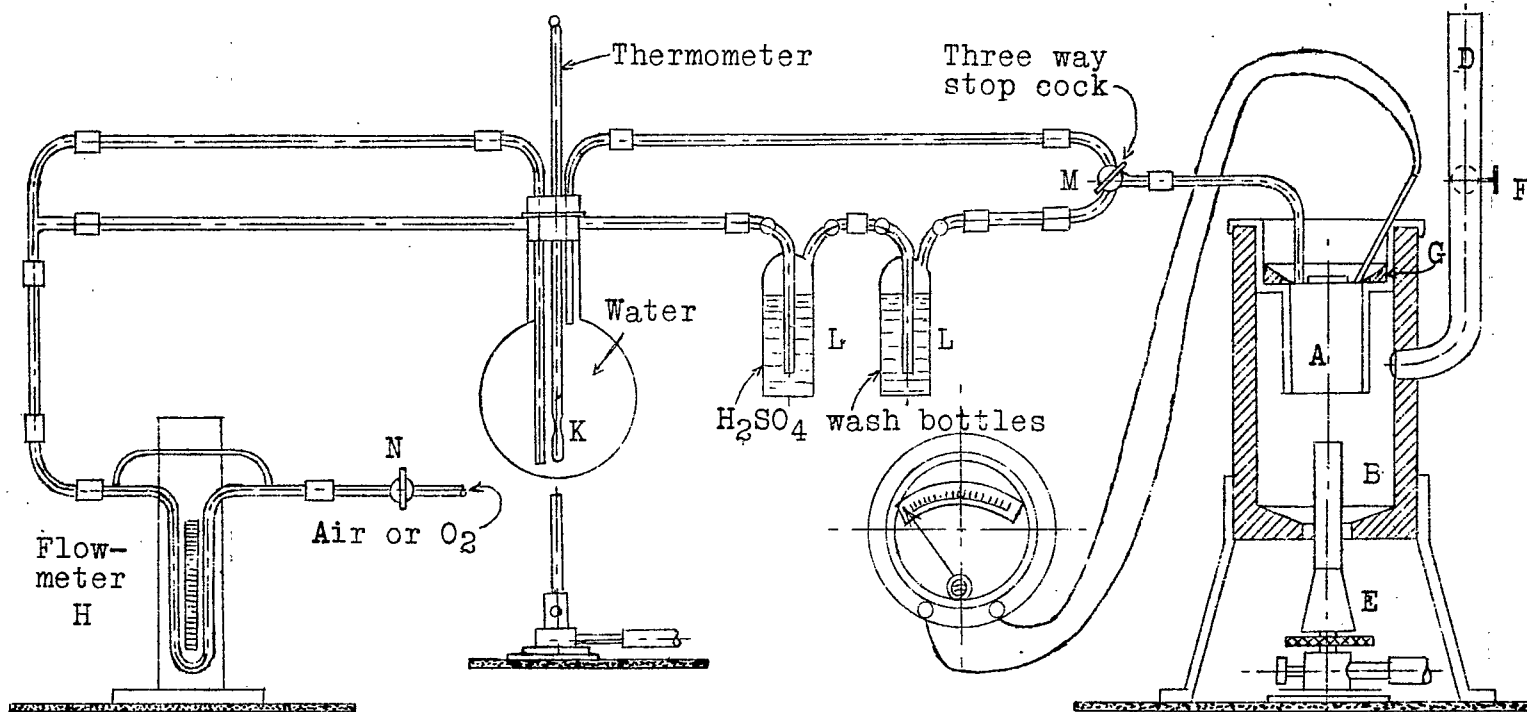

Fig. 1 Arrangement for measurement of ignition points at one atmosphere absolute.

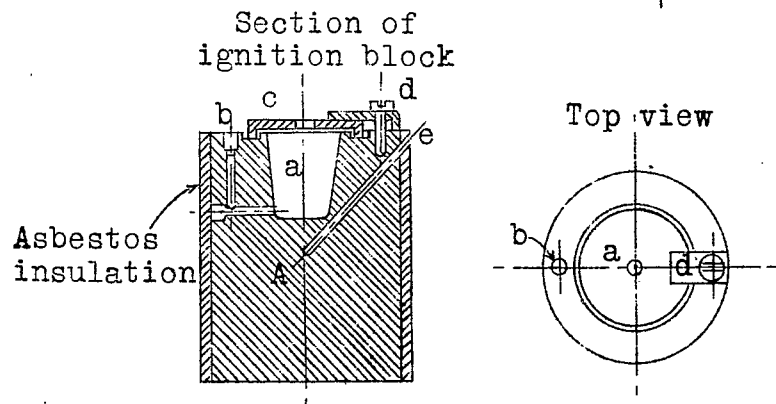

Fig. 1

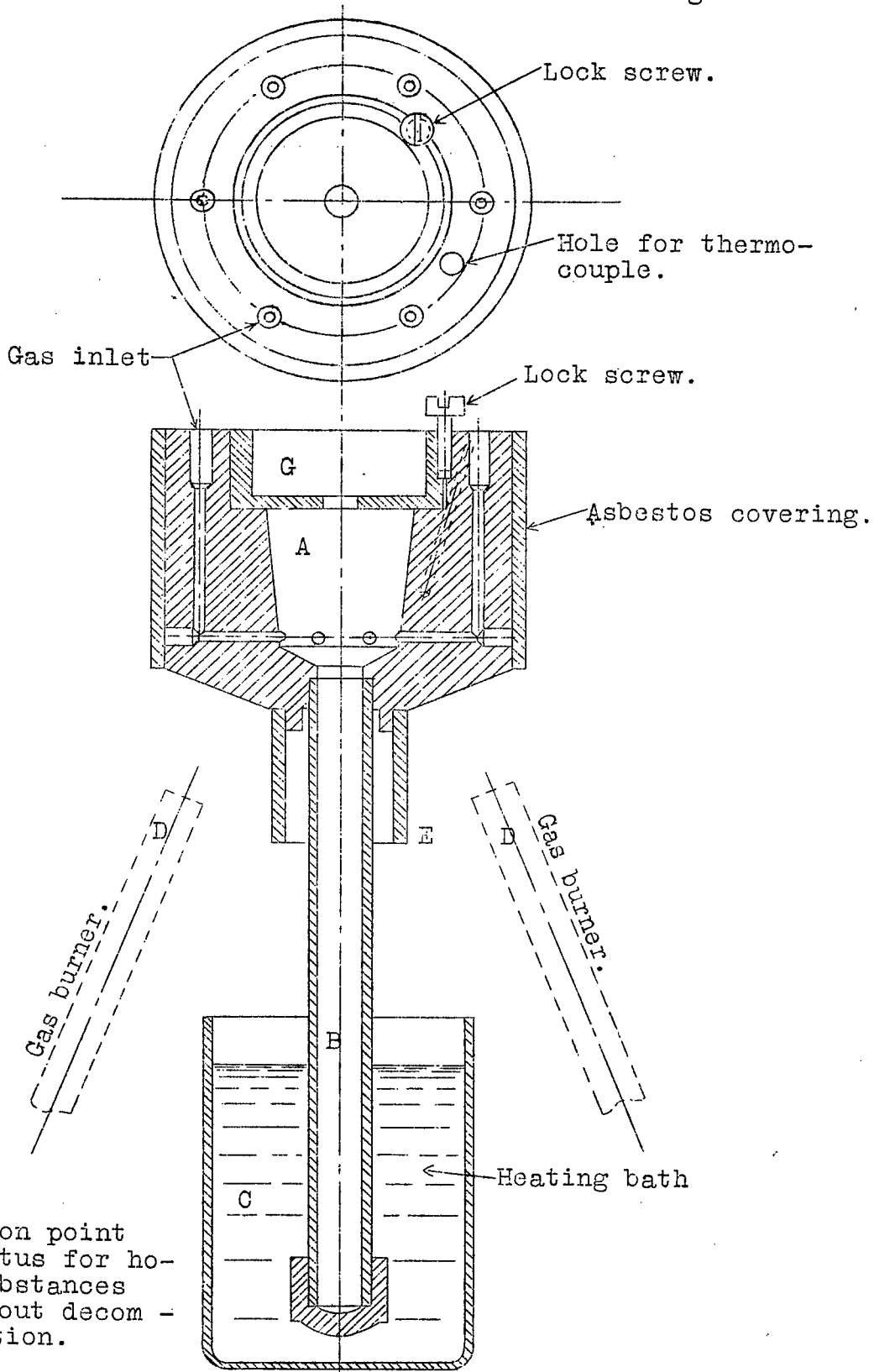
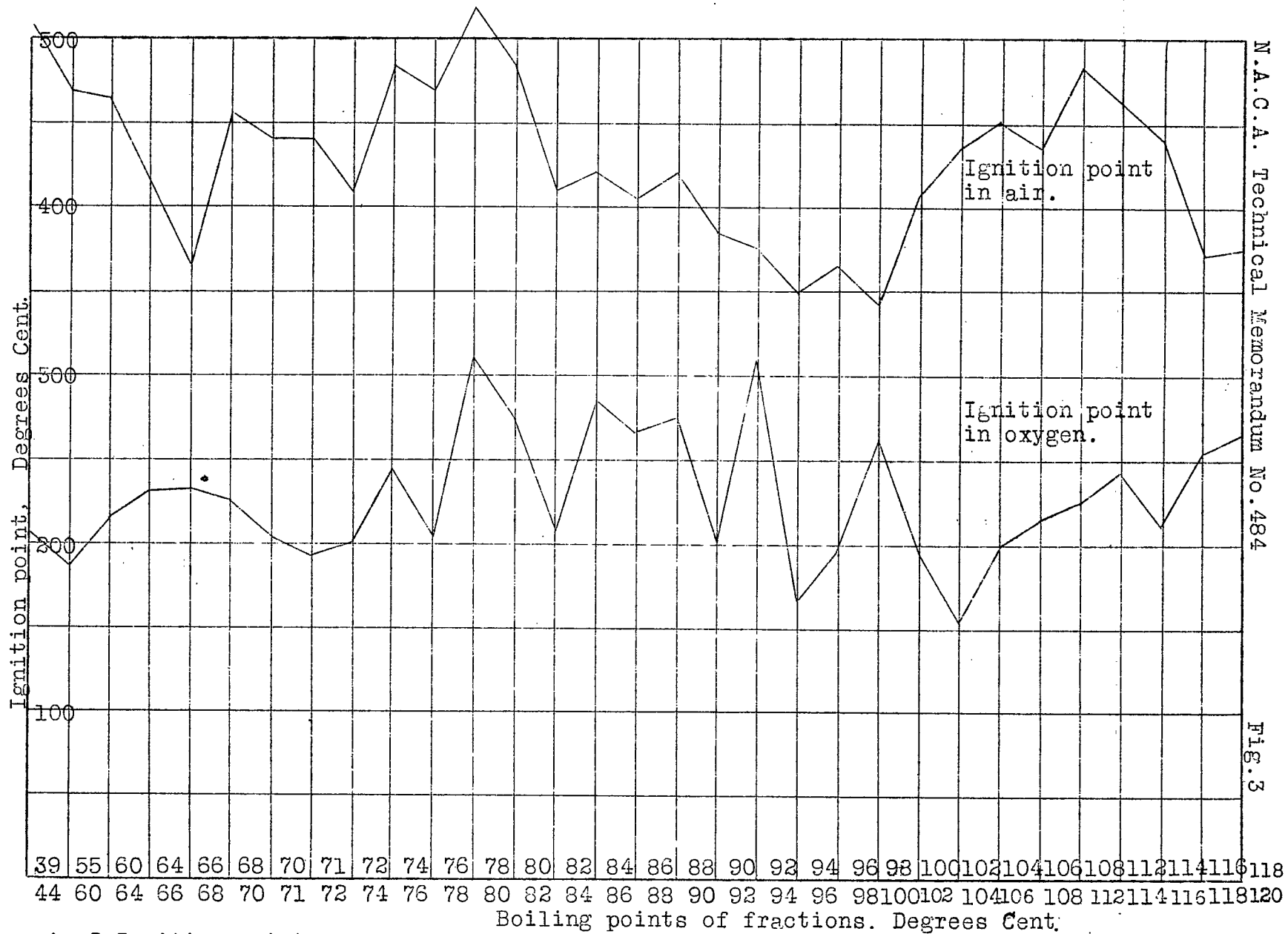

Fig.2 Ignition point apparatus for homogeneous substances boiling without decomposition.



N.A.C.A. Technical Memorandum No. 484

Fig. 3

Fig.3 Ignition points of shale oil distillates.

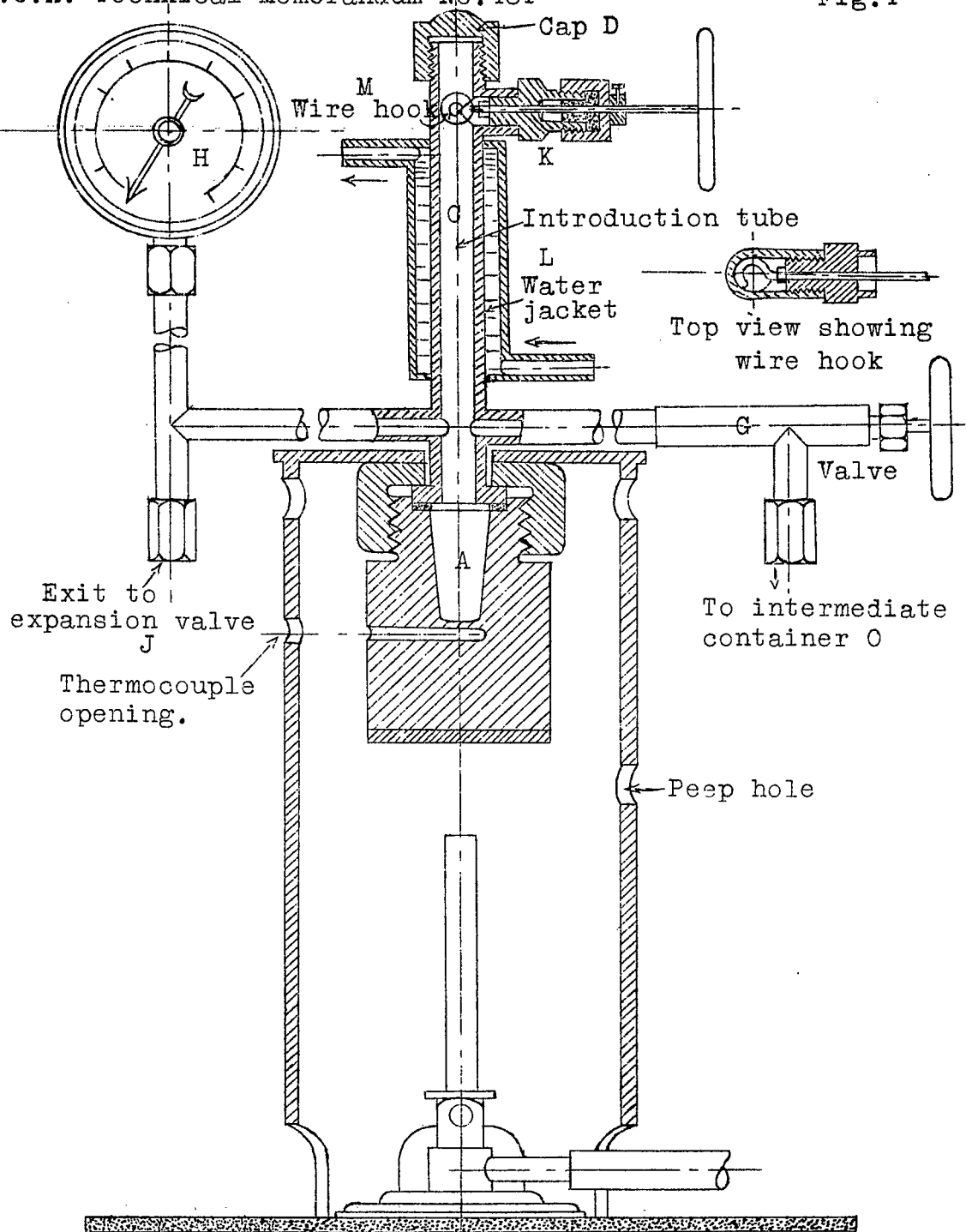

Fig.4 Ignition point measurement under pressure series A

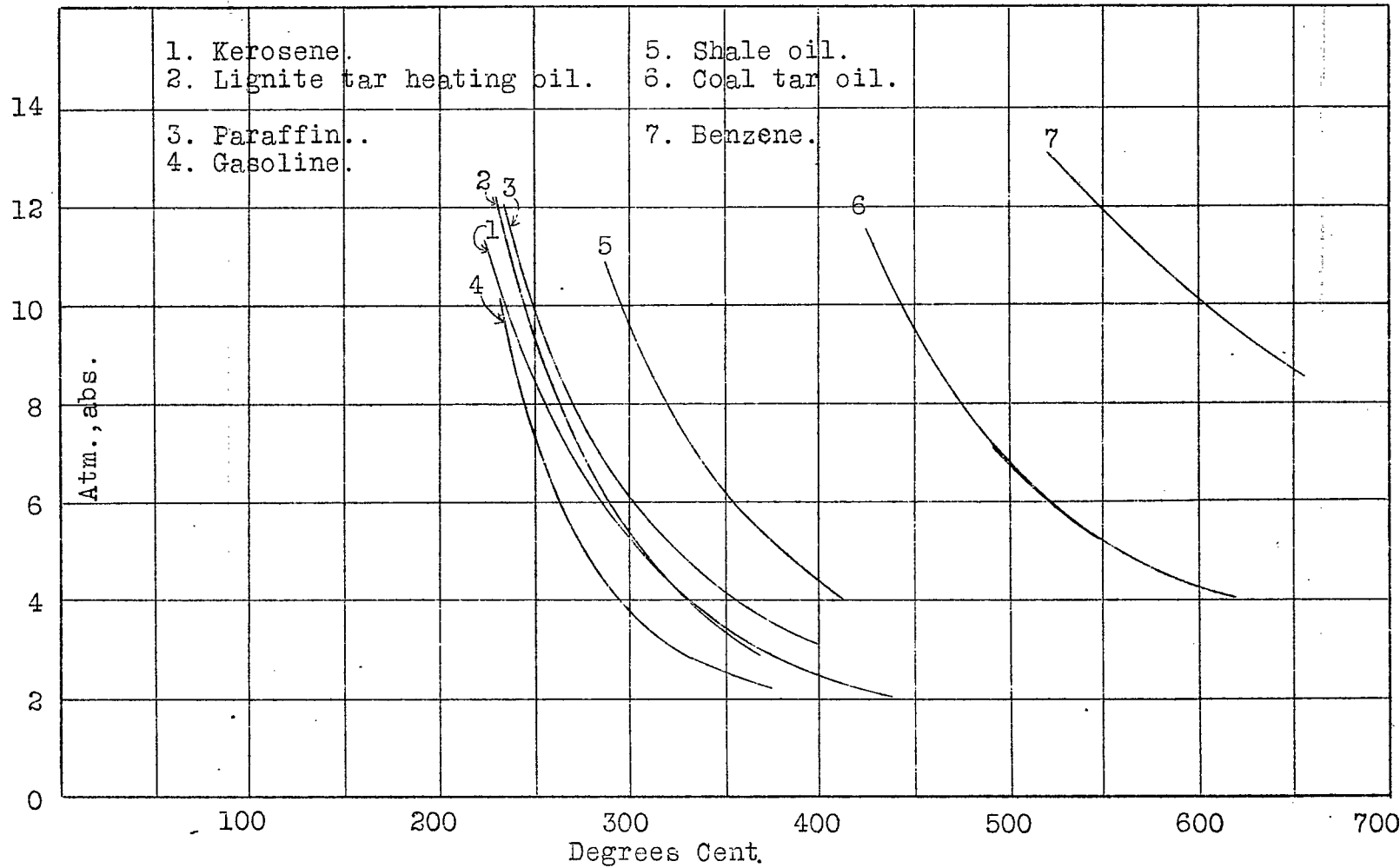

Fig.5 Results of pressure experiments A.



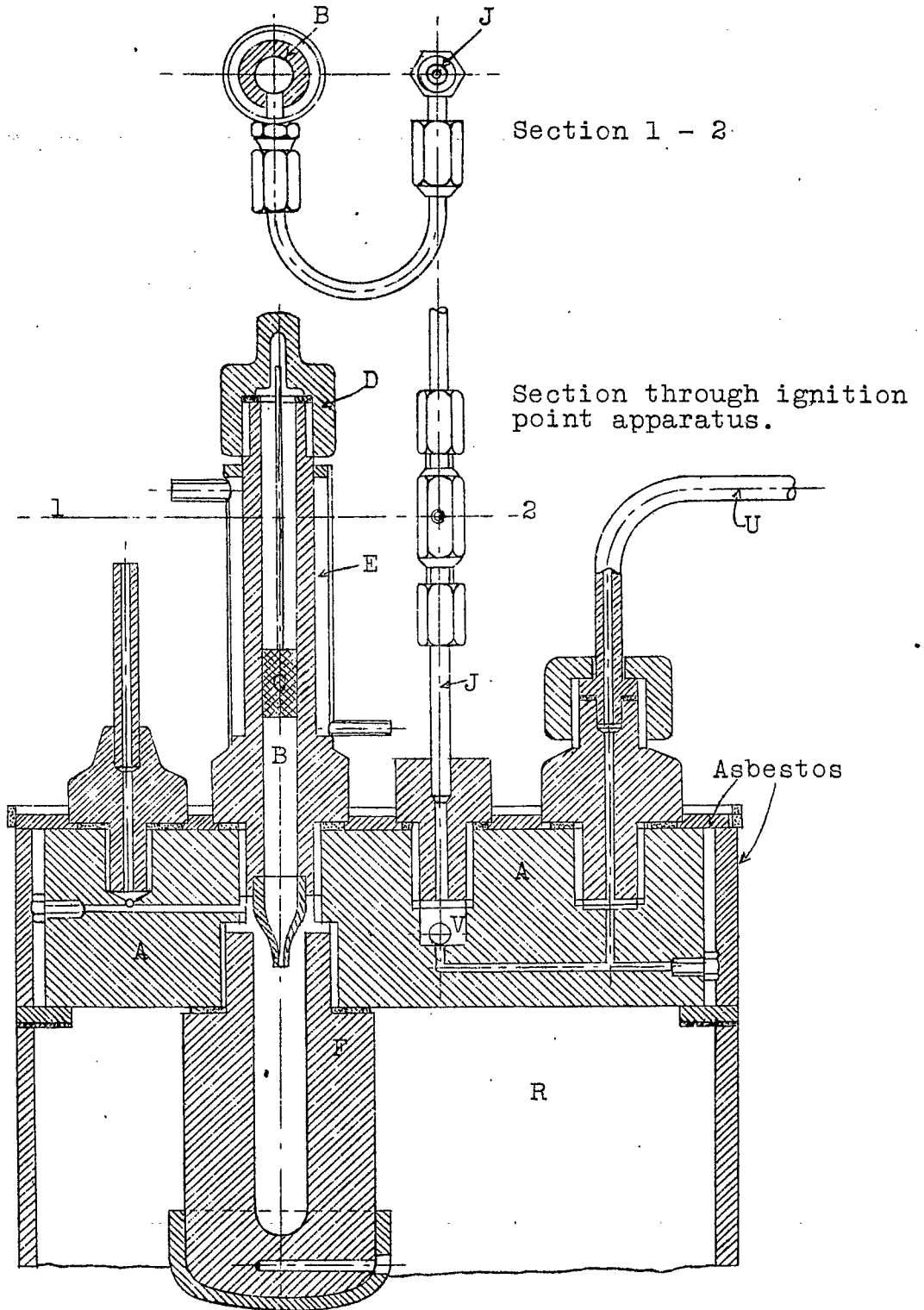

Fig.6 Ignition point measurement under pressure series B

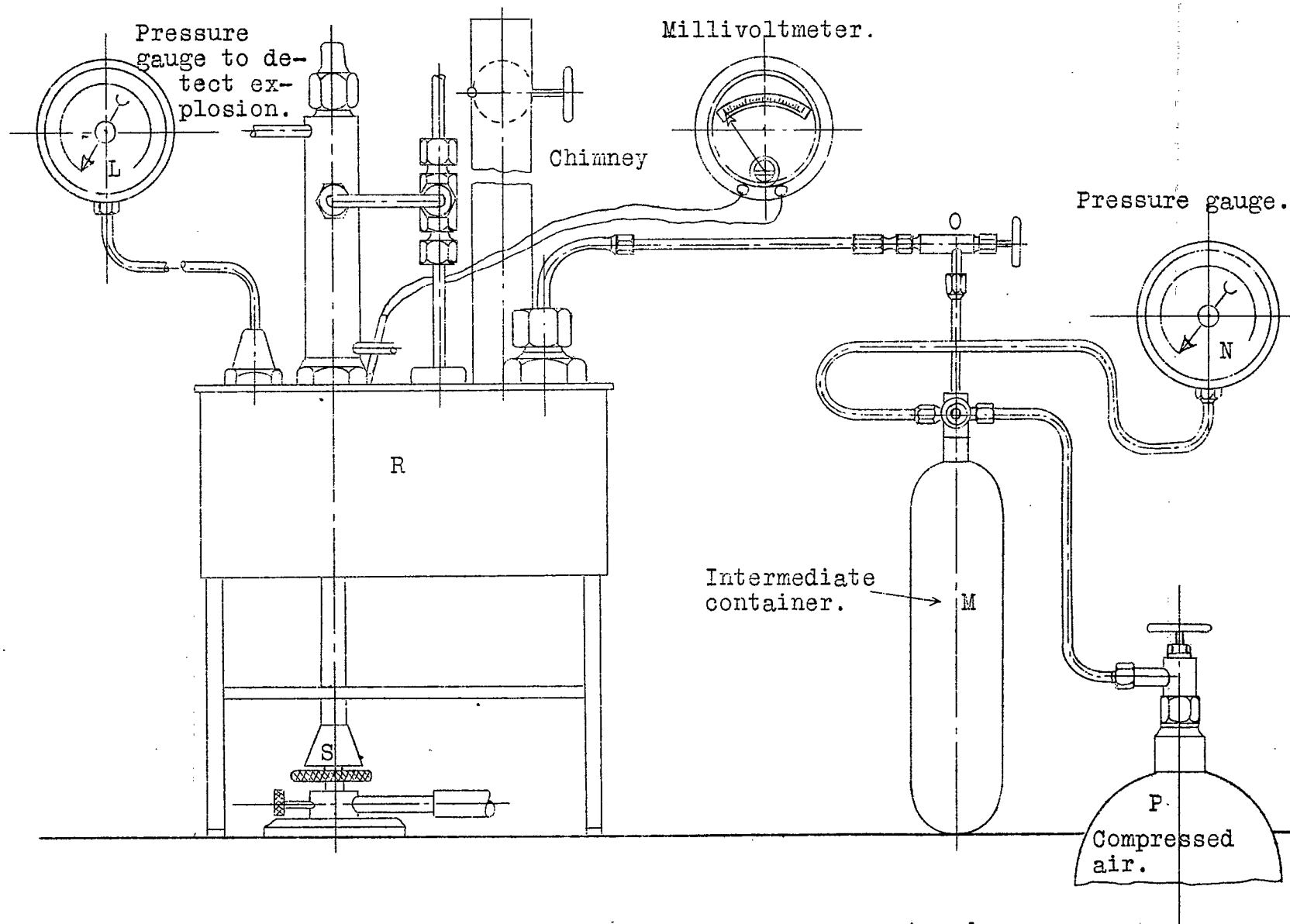

Fig.7 Arrangement for ignition point measurement under pressure. Series B.

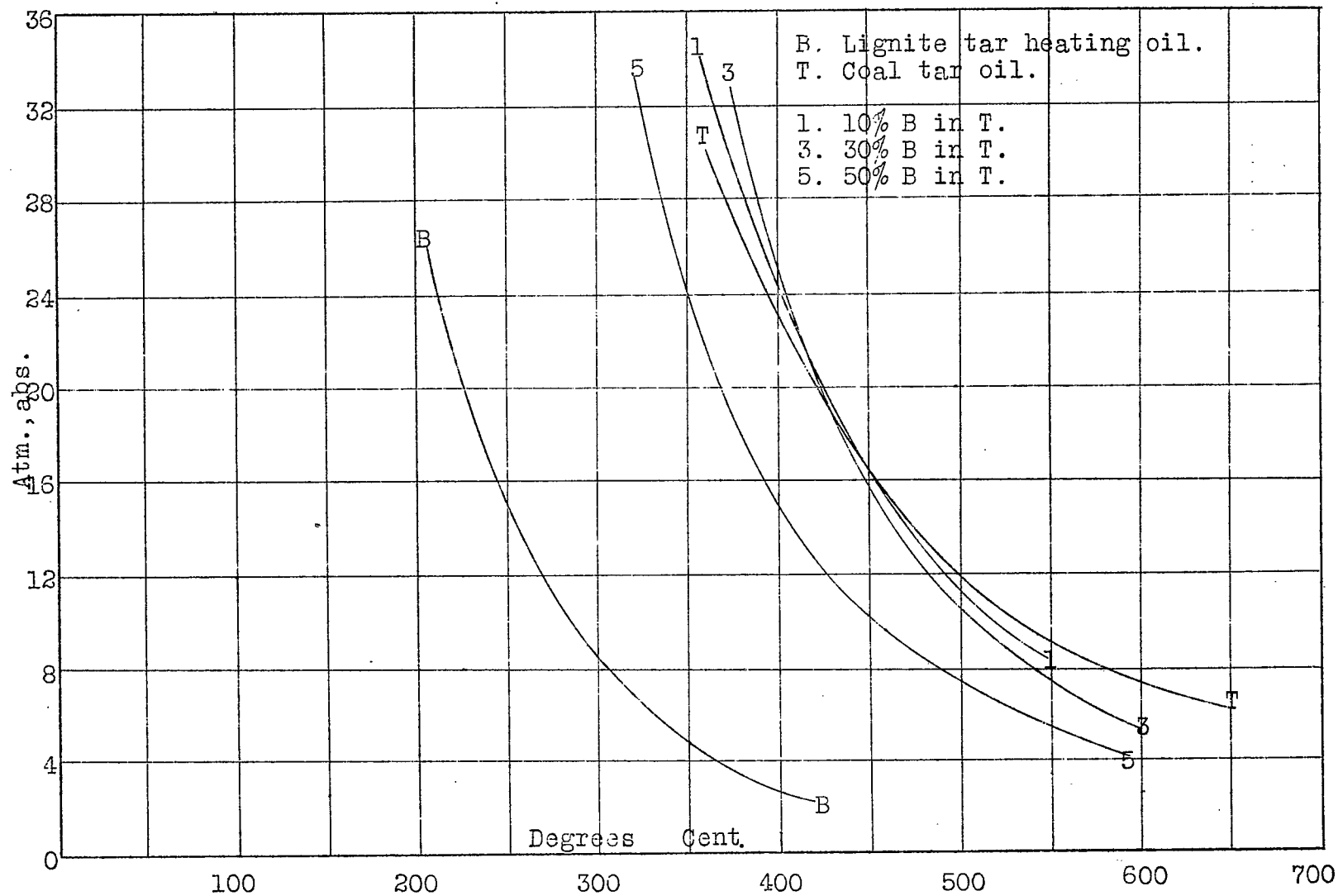

Fig. 8 Mixtures of lignite tar heating oil with coal tar oil. Pressure series B.

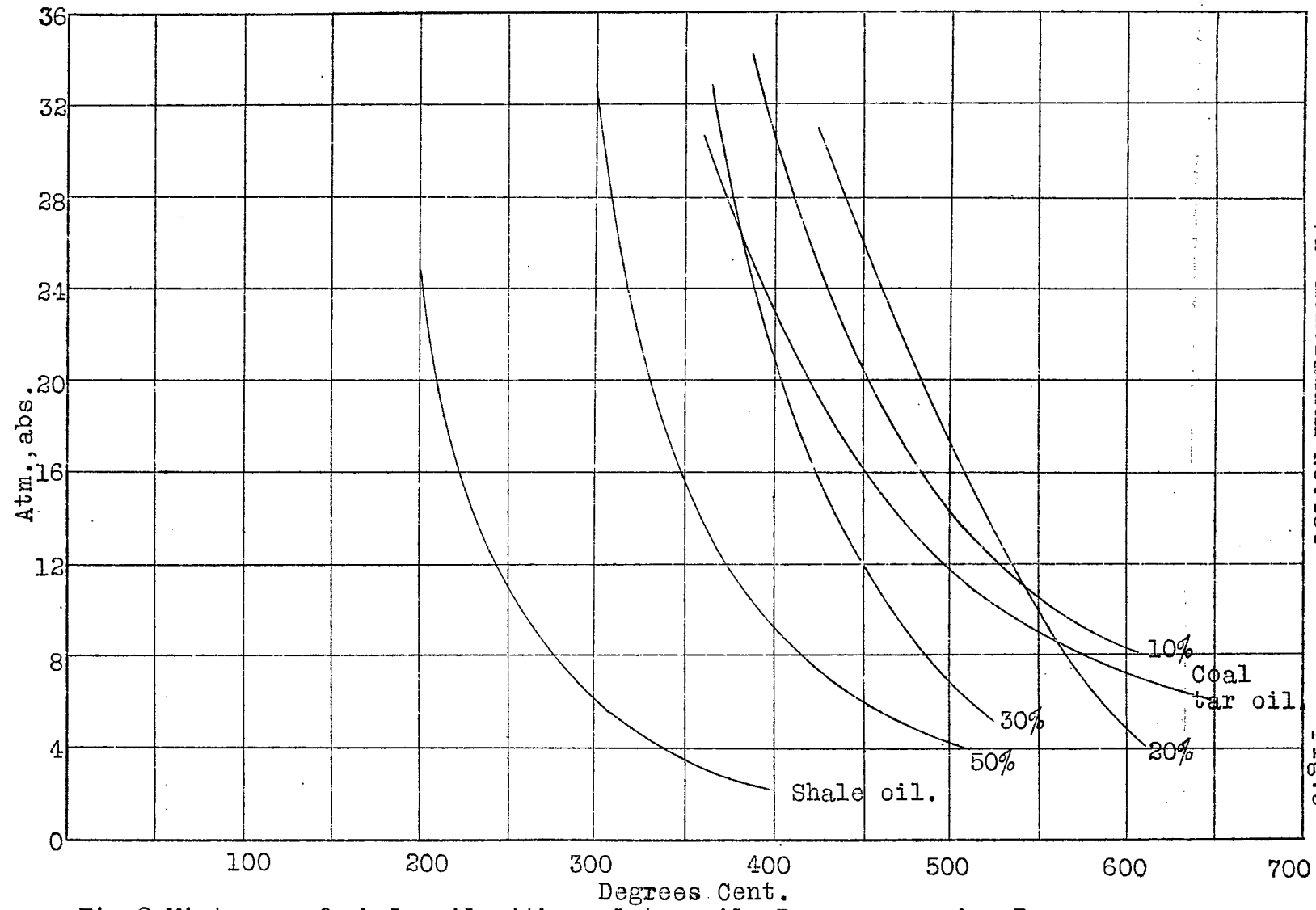

FIG. 9

Fig.9 Mixtures of shale oil with coal tar oil. Pressure series B.

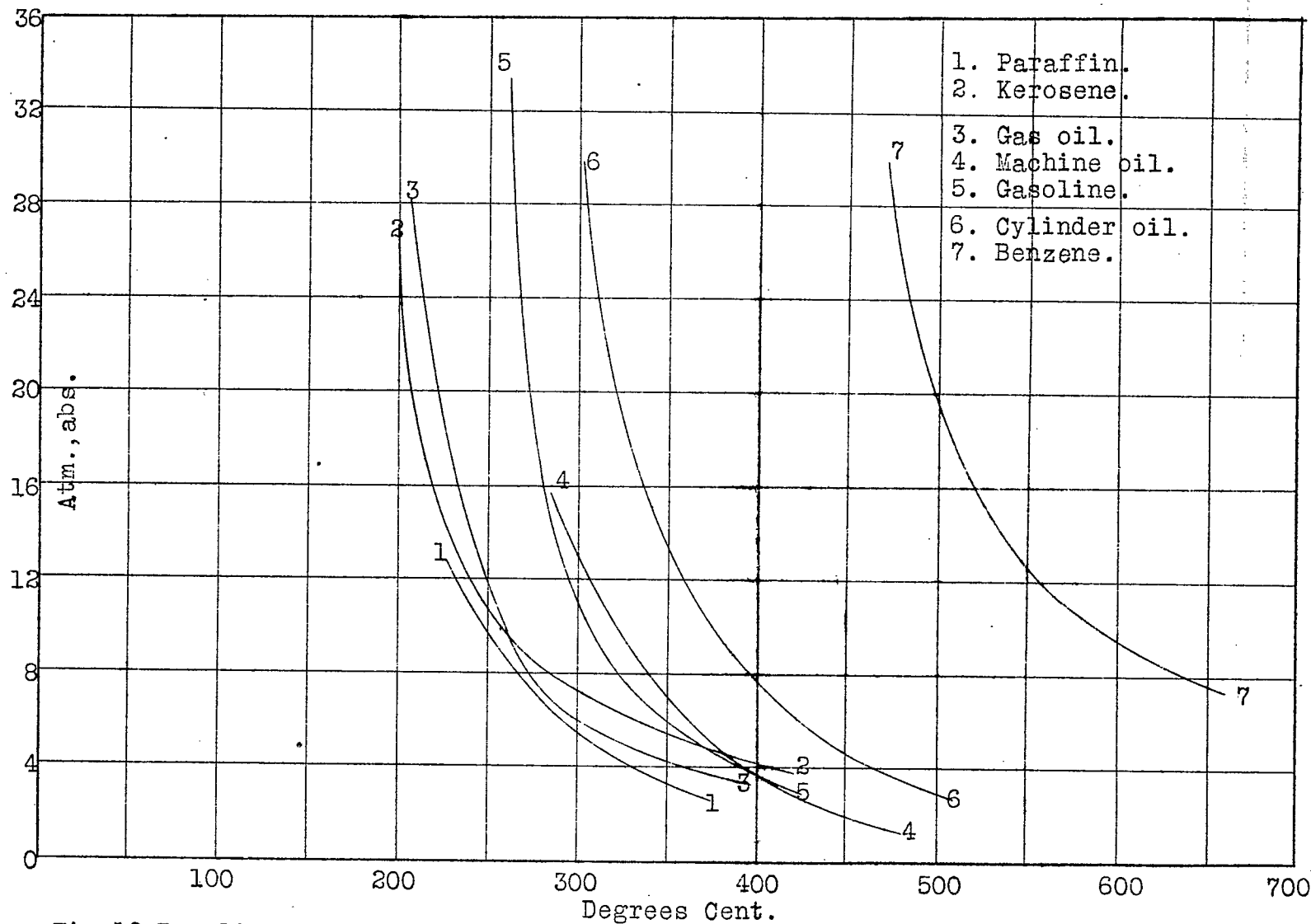

Fig.10 Results of pressure experiments B.

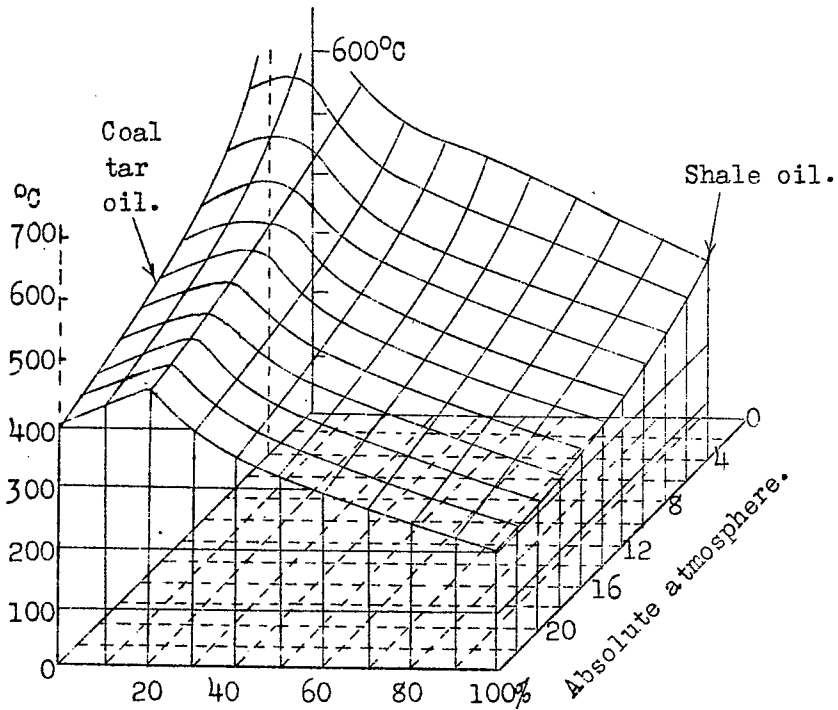

Fig.11 Ignition points of mixtures of shale oil and coal tar oil.

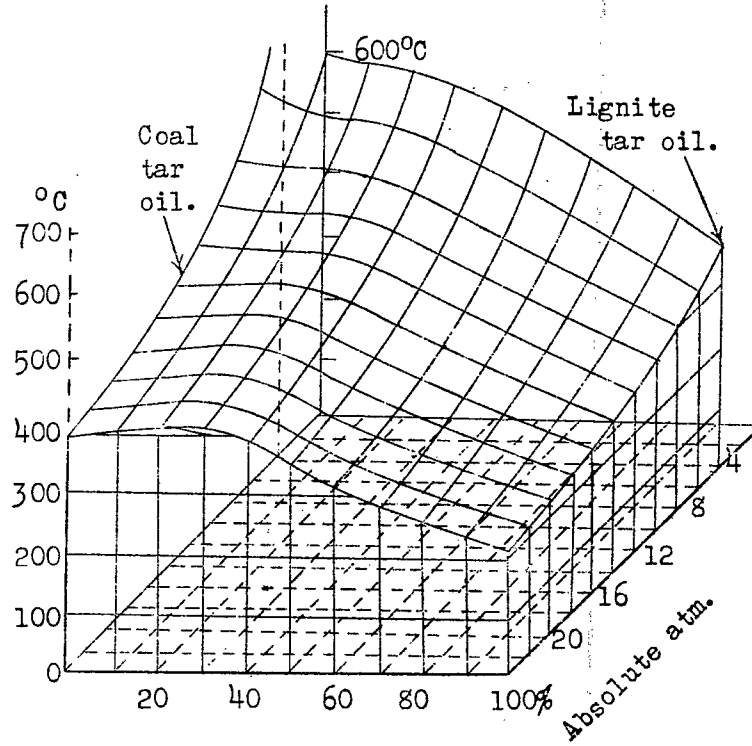

Fig.12 Ignition points of mixtures of lignite tar oil and coal tar oil.

NASA Technical Library



3 1176 01440 2102