

TN2396

TECH LIBRARY KAFB, NM
0143183

**NATIONAL ADVISORY COMMITTEE
FOR AERONAUTICS**

REPORT 1089

**SINGLE-DEGREE-OF-FREEDOM-FLUTTER CALCULATIONS
FOR A WING IN SUBSONIC POTENTIAL FLOW
AND COMPARISON WITH AN EXPERIMENT**

By **HARRY L. RUNYAN**



1952



REPORT 1089

**SINGLE-DEGREE-OF-FREEDOM-FLUTTER CALCULATIONS
FOR A WING IN SUBSONIC POTENTIAL FLOW
AND COMPARISON WITH AN EXPERIMENT**

By HARRY L. RUNYAN

**Langley Aeronautical Laboratory
Langley Field, Va.**

National Advisory Committee for Aeronautics

Headquarters, 1724 F Street NW, Washington 25, D. C.

Created by act of Congress approved March 3, 1915, for the supervision and direction of the scientific study of the problems of flight (U. S. Code, title 50, sec. 151). Its membership was increased from 12 to 15 by act approved March 2, 1929, and to 17 by act approved May 25, 1948. The members are appointed by the President, and serve as such without compensation.

JEROME C. HUNSAKER, Sc. D., Massachusetts Institute of Technology, *Chairman*

ALEXANDER WETMORE, Sc. D., Secretary, Smithsonian Institution, *Vice Chairman*

ALLEN V. ASTIN, Ph. D., Director, National Bureau of Standards.
DETLEV W. BRONK, Ph. D., President, Johns Hopkins University.

THOMAS S. COMBS, Rear Admiral, United States Navy, Chief of Bureau of Aeronautics.

LAURENCE C. CRAIGIE, Lieutenant General, United States Air Force, Deputy Chief of Staff (Development).

HON. THOMAS W. S. DAVIS, Assistant Secretary of Commerce.

JAMES H. DOOLITTLE, Sc. D., Vice President, Shell Oil Co.

MATTHIAS B. GARDNER, Vice Admiral, United States Navy, Deputy Chief of Naval Operations (Air).

R. M. HAZEN, B. S., Director of Engineering, Allison Division, General Motors Corp.

WILLIAM LITTLEWOOD, M. E., Vice President, Engineering, American Airlines, Inc.

HON. DONALD W. NYROP, Chairman, Civil Aeronautics Board.

DONALD L. PUTT, Major General, United States Air Force, Vice Commander, Air Research and Development Command.

ARTHUR E. RAYMOND, Sc. D., Vice President, Engineering, Douglas Aircraft Co., Inc.

FRANCIS W. REICHELDERFER, Sc. D., Chief, United States Weather Bureau.

HON. WALTER G. WHITMAN, Chairman, Research and Development Board, Department of Defense.

THEODORE P. WRIGHT, Sc. D., Vice President for Research, Cornell University.

HUGH L. DRYDEN, Ph. D., *Director*

JOHN W. CROWLEY, JR., B. S., *Associate Director for Research*

JOHN F. VICTORY, LL. D., *Executive Secretary*

E. H. CHAMBERLIN, *Executive Officer*

HENRY J. E. REID, D. Eng., Director, Langley Aeronautical Laboratory, Langley Field, Va.

SMITH J. DEFRANCE, LL. D., Director, Ames Aeronautical Laboratory, Moffett Field, Calif.

EDWARD R. SHARP, Sc. D., Director, Lewis Flight Propulsion Laboratory, Cleveland Airport, Cleveland, Ohio

LANGLEY AERONAUTICAL LABORATORY,
Langley Field, Va.

AMES AERONAUTICAL LABORATORY,
Moffett Field, Calif.

LEWIS FLIGHT PROPULSION LABORATORY,
Cleveland Airport, Cleveland, Ohio

Conduct, under unified control, for all agencies, of scientific research on the fundamental problems of flight

REPORT 1089

SINGLE-DEGREE-OF-FREEDOM-FLUTTER CALCULATIONS FOR A WING IN SUBSONIC POTENTIAL FLOW AND COMPARISON WITH AN EXPERIMENT¹

By HARRY L. RUNYAN

SUMMARY

A study of single-degree-of-freedom pitching oscillations of a wing has been presented. This study includes the effects of Mach number and structural damping and is primarily an extension of a recent paper by Smilg in which incompressible flow was considered. The actual existence of single-degree-of-freedom flutter was demonstrated by some low-speed tests of a wing, pivoted a short distance ahead of the leading edge with a geometric aspect ratio of 5.87. In general, good agreement was found between experimental and calculated results for high values of an inertia parameter corresponding to high altitudes, but differences exist for low values of the inertia parameter. The effect of aspect ratio has not been considered in the calculations and could have an appreciable influence on the oscillation.

INTRODUCTION

The possibility of the existence of single-degree-of-freedom oscillatory instability or flutter in incompressible flow, both potential and separated, has been known for some time. As early as 1929 Glauert (reference 1) noted the possible loss of damping of a pitching wing in incompressible flow which might lead to an oscillatory instability that may be referred to as single-degree-of-freedom flutter. In 1937 Possio made similar observations for supersonic flow (reference 2) and in 1946 this study was elaborated on by Garrick and Rubinow (reference 3), who observed that, under certain conditions, a single-degree-of-freedom oscillation is possible in incompressible flow. Subsequently, Smilg (reference 4) made calculations showing the ranges of axis-of-rotation location and an inertia parameter which could lead to an oscillatory instability in pitch or yaw for the incompressible case. Also, Miles (reference 5) has indicated that calculations of stability derivatives based on steady air forces might lead to erroneous damping derivatives, especially for high-speed and short-tail-length aircraft. In addition, he pointed out that the compressibility effects in nonstationary flow are not correctly taken into account by simply introducing the Prandtl-Glauert factor since compressibility induces additional phase lags.

Until recently whatever interest was shown in single-degree-of-freedom flutter was largely academic because the ranges of parameters involved did not appear practical. However, with current airplanes and missiles designed for high speeds and high altitudes, the subject becomes a more practical one, for under these conditions undamped oscillations of even very small amplitude may become important. In addition, calculations of single-degree-of-freedom flutter may represent a useful, easily obtained limit for cases of coupled flutter involving other degrees of freedom.

This report considers specifically the type of single-degree-of-freedom flutter associated with the pitching of an airfoil about various locations of the axis of rotation. It extends the work of reference 4 to include the effects of Mach number up to $M=0.7$ and discusses the effect of structural damping for one location of the axis of rotation. The results of an experimental investigation which confirms the existence of single-degree-of-freedom flutter are compared with the theoretical values. The calculations were based on two-dimensional aerodynamic-force coefficients and involved a single degree of freedom. The effect of aspect ratio and the coexistence of other degrees of freedom would modify the results to a large extent.

SYMBOLS

a	nondimensional distance from midchord to axis of rotation, based on half-chord, positive rearward
b	half-chord
c	spring constant
C_α	coefficient of torsional rigidity per unit length
d	damping coefficient
F and G	functions of k for oscillating plane flow
g_α	structural damping coefficient
I_α	moment of inertia about axis of rotation per unit length
$\bar{I}_{\alpha\alpha}$	out-of-phase (imaginary) component of moment on airfoil about axis of rotation per unit length
k	reduced frequency ($b\omega/v$)
m	mass
M	Mach number

¹ Supersedes NACA TN 2396, "Single-Degree-of-Freedom-Flutter Calculations for a Wing in Subsonic Potential Flow and Comparison With an Experiment" by Harry L. Runyan, 1951.

M_α	aerodynamic moment per unit length
M_r, M_r'	real part of aerodynamic moment for incompressible and compressible flow, respectively
M_n, Z_n	aerodynamic flutter coefficients (see reference 6) ($n=1,2,3,4$)
$\bar{R}_{\alpha\alpha}$	in-phase (real) component of moment on airfoil about axis of rotation per unit length
v	flutter velocity
x	displacement
α	angular displacement about axis of rotation, positive in stalling direction
ρ	fluid density
ω	circular frequency at flutter
ω_α	natural circular frequency

ANALYSIS

INTRODUCTORY CONSIDERATIONS

Before the specific example of single-degree-of-freedom pitching flutter is discussed, it may be advantageous first to review the concept of a single-degree-of-freedom vibrating system and then to show the relation of this example to an aerodynamic system. The linear differential equation for a free system consisting of a mass m , a spring having a spring constant c , and a viscous damper having a coefficient d is

$$m\ddot{x} + d\dot{x} + cx = 0 \quad (1)$$

The motion represented by this equation is damped if d is a positive quantity, as is ordinarily the case. If d should be negative, the motion is undamped, a condition of dynamic instability exists, and, if d is zero, harmonic oscillations corresponding to a borderline condition between damped and undamped motion may exist.

For a system such as an aircraft wing oscillating in a steady air stream, the same type of equation would apply as for the mass-spring-damper system previously mentioned. However, the coefficients m , d , and c of equation (1) will now have added components associated with the aerodynamics. The equation for a wing oscillating in pitch in a steady two-dimensional air stream is

$$I_\alpha \ddot{\alpha} + (1 + ig_\alpha) C_\alpha \alpha = M_\alpha(\alpha, \dot{\alpha}, \ddot{\alpha}, \dots) \quad (2)$$

where M_α represents the complex aerodynamic moment, which is a function in part of amplitude α , velocity $\dot{\alpha}$, acceleration $\ddot{\alpha}$, reduced frequency $k = \frac{b\omega}{v}$, location of axis of rotation a , Mach number M , and sweep angle. Equation (2) is complex and may be separated into two components: one associated with the damping of the system (sometimes called the imaginary part) and the other associated with the flutter frequency and velocity (sometimes called the real part).

EQUATION FOR PITCHING OSCILLATIONS, $M=0$

From reference 7, the values of the damping equation and the frequency equation for two-dimensional incompressible flow are as follows:

Damping equation

$$\bar{I}_{\alpha\alpha} = \frac{1}{k} \left[-\left(\frac{1}{2} + a\right) \frac{2G}{k} - \left(\frac{1}{4} - a^2\right) 2F + \left(\frac{1}{2} - a\right) \right] + g_\alpha \frac{I_\alpha}{\pi \rho b^4} \left(\frac{\omega_\alpha}{\omega}\right)^2 = 0 \quad (3)$$

Frequency equation

$$\bar{R}_{\alpha\alpha} = -\left(\frac{1}{8} + a^2\right) + \left(\frac{1}{4} - a^2\right) \frac{2G}{k} - \left(\frac{1}{2} + a\right) \frac{2F}{k^2} + \frac{I_\alpha}{\pi \rho b^4} \left[\left(\frac{\omega_\alpha}{\omega}\right)^2 - 1 \right] = 0 \quad (4)$$

Equation (3) is equivalent to the vanishing of the damping coefficient d of equation (1) and thus represents a borderline condition between damped and undamped oscillations. The flutter frequency and velocity may then be determined from equation (4).

Equation (3) cannot be solved explicitly for k since the functions F and G are transcendental functions of k . There are several methods of solving this equation; a convenient one, given in reference 8, is to assume values of $1/k$ and solve for the structural damping coefficient. The type of structural damping force commonly used in flutter calculation is in phase with the velocity but proportionate to the amplitude. If the damping coefficient is plotted against $1/k$, the value of $1/k$ for any given damping coefficient may be determined. When the value of $1/k$ that satisfies the imaginary or damping part of the moment equation has been determined, the frequency of oscillation and the velocity may be determined from the real part of the moment equation (equation (4)). Equation (4) may be put in different form as follows:

$$\left(\frac{\omega}{\omega_\alpha}\right)^2 = \frac{1}{1 - M_r \frac{\pi \rho b^4}{I_\alpha}} \quad (5)$$

where

$$M_r = -\frac{3}{8} + \left(\frac{1}{2} + a\right) \left(\frac{1}{2} + \frac{2G}{k} - \frac{2F}{k^2}\right) - \frac{1}{2} \left(\frac{1}{2} + a\right) + \left(\frac{1}{2} + a^2\right) \left(1 + \frac{2G}{k}\right)$$

If the torsional restraint ω_α is zero, equation (5) reduces to

$$\frac{I_\alpha}{\pi \rho b^4} = M_r \quad (6)$$

so that, if the value of the inertia parameter $I_\alpha/\pi \rho b^4$ exceeds

the value of M_r for the given axis-of-rotation location, the oscillation can exist at all airspeeds above zero speed. The frequency is then a direct function of the velocity as defined by the following equation:

$$v = \frac{b\omega}{k} \tag{7}$$

where $1/k$ is the value of the flutter-speed parameter associated with the borderline condition between damped and undamped oscillation for the given axis of rotation.

EQUATION FOR PITCHING OSCILLATION INCLUDING MACH NUMBER

In order to consider the effect of Mach number, the results of reference 6 may be used. The method of computation is the same as described in the preceding section; however, the aerodynamic moment M_α has been redefined to include the effect of Mach number.

The damping (imaginary) component (see references 6 and 7) is

$$\bar{I}_{\alpha\alpha} = g_\alpha \left(\frac{\omega_\alpha}{\omega} \right)^2 \frac{I_\alpha}{\pi \rho b^4} + \frac{4}{k^2} \left[M_4 - \frac{1}{2} \left(\frac{1}{2} + a \right) \left(M_2 + Z_4 - \frac{a}{2} Z_2 \right) \right] + \frac{1}{k^2} M_2 = 0 \tag{8}$$

and the frequency (real) equation is

$$\left(\frac{\omega}{\omega_\alpha} \right)^2 = \frac{1}{1 - M_r' \frac{\pi \rho b^4}{I_\alpha}}$$

where

$$M_r' = \frac{4}{k^2} \left[M_3 - \frac{1}{2} \left(\frac{1}{2} + a \right) \left(M_1 + Z_3 - \frac{a}{2} Z_1 \right) \right] + \frac{1}{k^2} M_1$$

The aerodynamic coefficients M_n and Z_n are functions only of reduced frequency k and Mach number (see reference 6).

ANALYTICAL RESULTS

The purpose of this section is to show the results of some calculations made to determine the effect of some of the independent variables on the flutter speed and flutter frequency.

In figure 1, the flutter-speed parameter $v/b\omega_\alpha$ is plotted against the inertia parameter $I_\alpha/\pi\rho b^4$ for three Mach numbers, $M=0$, $M=0.5$, and $M=0.7$. The region to the right and above a given curve is the unstable region, whereas the region to the left and below is the stable region. Increasing altitude is equivalent to increasing values of the inertia parameter. (Note the large change in scale of figs.1 (a) to 1 (f).)

As an illustration of the meaning of the curves of figure 1, the $M=0$ case of figure 1 (a) ($a=-1.0$) is discussed. If the

value of the inertia parameter is below 571 (the asymptote), the configuration will be stable. As the altitude is increased, the inertia parameter will increase and, if it is equal to 571, the velocity at which an unstable oscillation could occur would be infinite. A slight increase in the inertia parameter would now have a very great effect in reducing the critical velocity. For very large values of the inertia parameter, the curve is asymptotic to a value of $v/b\omega_\alpha$ which is equal to the reduced velocity $v/b\omega$ (that is, $1/k$), which for this case is 24.7.

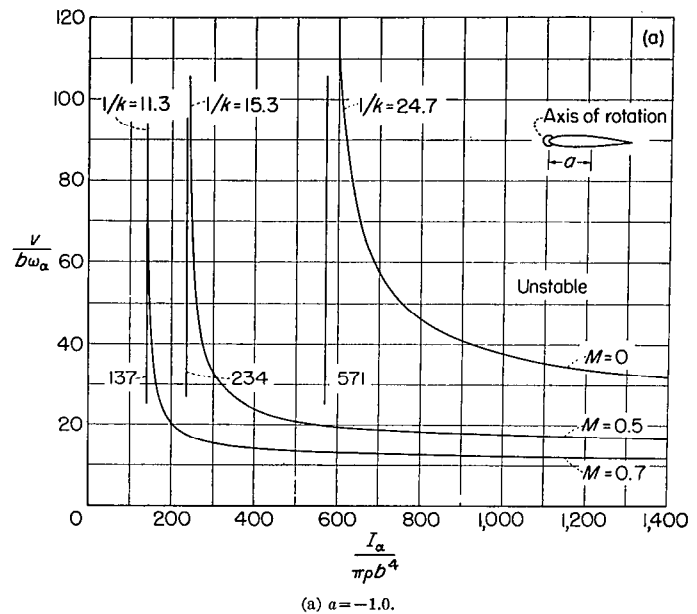

FIGURE 1.—Plot of $v/b\omega_\alpha$ against $I_\alpha/\pi\rho b^4$ for single-degree-of-freedom pitching oscillation for various axis-of-rotation positions a for several Mach numbers.

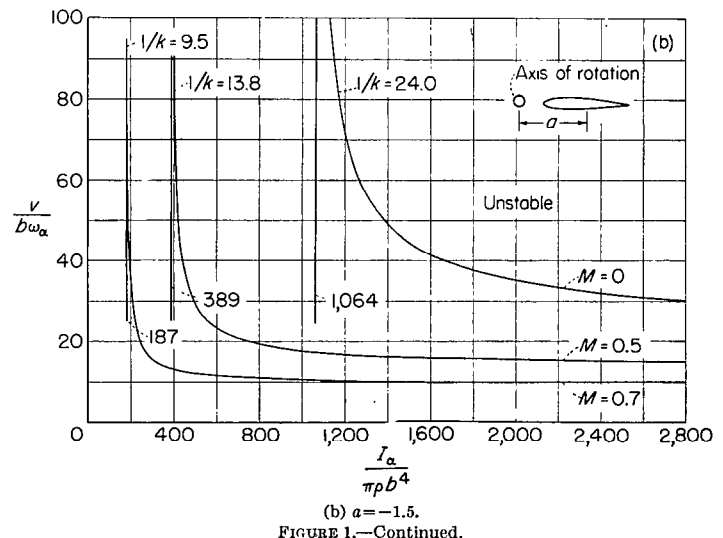
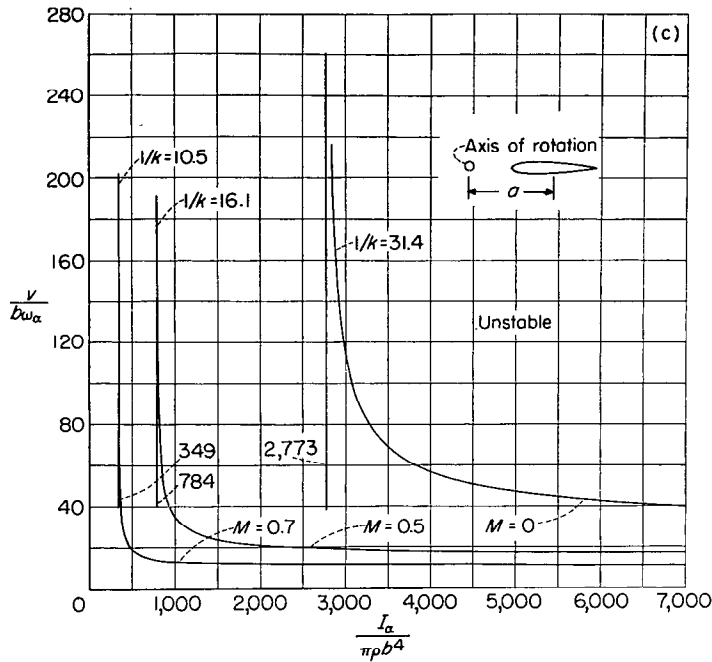

FIGURE 1.—Continued.

The effect of Mach number is now examined. First, and most important, a large reduction in the stable region is to be noted. For example, in figure 1 (a), the upper limit of the stable region for $M=0$ for the inertia parameter $I_a/\pi\rho b^4$ is 571 and this limit is reduced to 137 at $M=0.7$.

Another effect is that, for a given speed v , the frequency of oscillation would increase for an increase in Mach number. For instance, in figure 1 (a), the frequency of oscillation would be increased by a factor of 2 with an increase in Mach number from 0 to 0.7.



(c) $a = -2.0$.
FIGURE 1.—Continued.

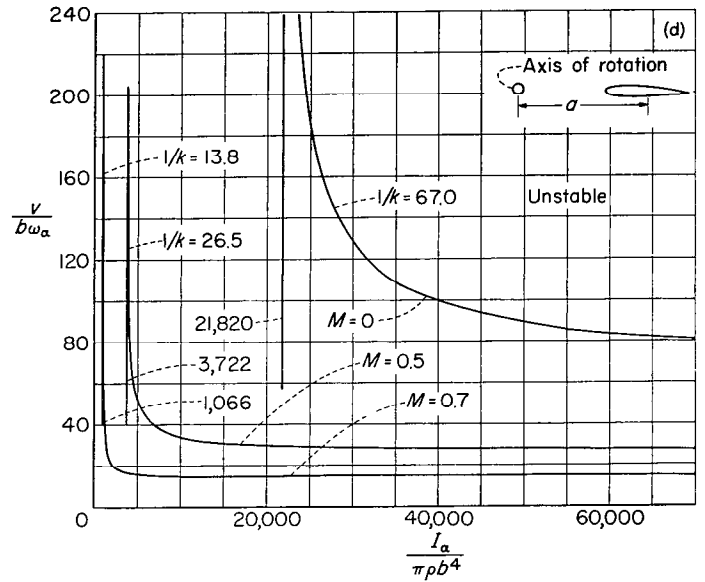

(d) $a = -3.0$.
FIGURE 1.—Continued.

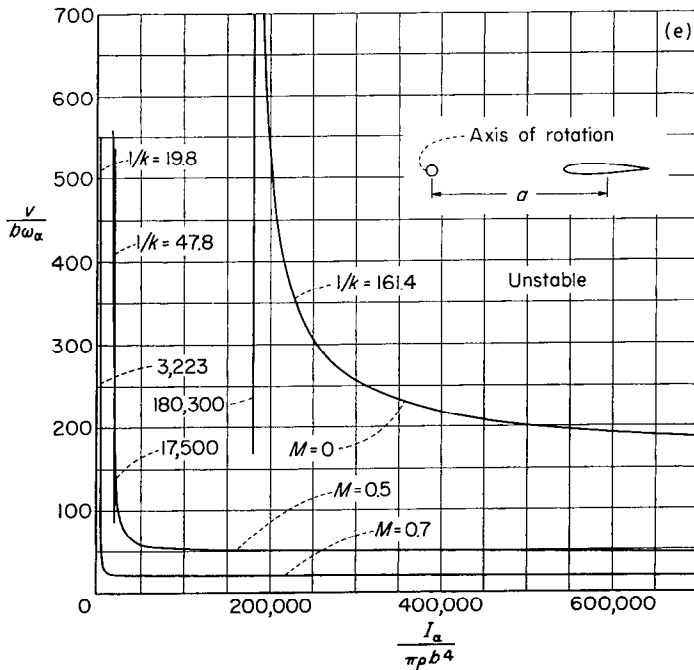

(e) $a = -4.0$.
FIGURE 1.—Continued.

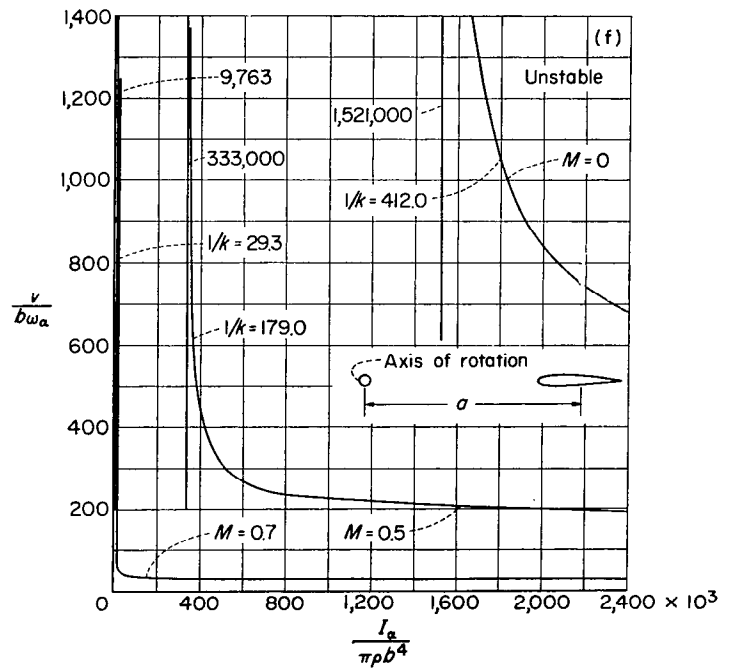

(f) $a = -5.0$.
FIGURE 1.—Concluded.

In figure 2, the frequency ratio $(\omega/\omega_\alpha)^2$ is plotted against the inertia parameter $I_\alpha/\pi\rho b^4$. This curve has the same vertical asymptote for the inertia parameter as for the corresponding reduced-velocity curve (fig. 1) and the unstable region is again to the right and above the curve. The inertia parameter increases as the altitude increases. At low values of the inertia parameter the configuration is stable. The frequency of oscillation is infinite at the asymptotic value of the inertia parameter and decreases rapidly as the inertia

parameter is increased further. For very large values of the inertia parameter, the curve is asymptotic to the natural frequency ω_α of the system. In figure 3, the minimum asymptotic value of the inertia parameter $I_\alpha/\pi\rho b^4$ at which the oscillation could begin is plotted against Mach number for various positions of the axis of rotation. An important effect to be noted is that, as the distance of the axis of rotation from the lifting surface is increased, the effect of Mach number becomes increasingly greater.

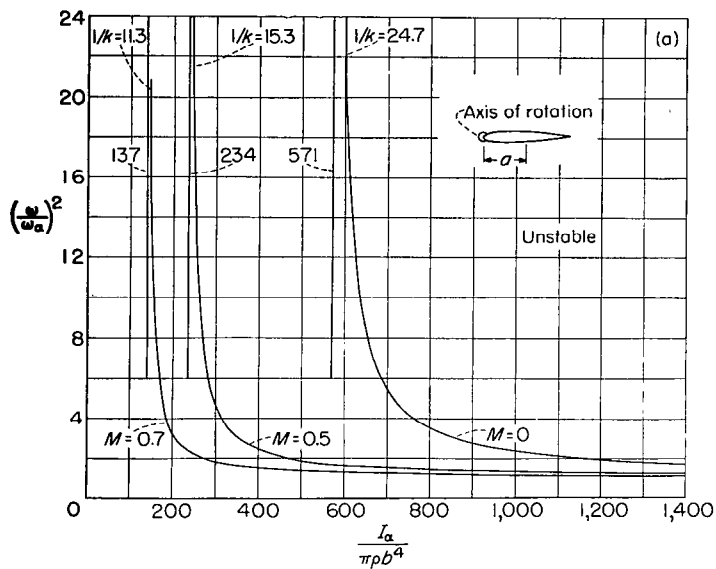

(a) $a = -1.0$.

FIGURE 2.—Plot of $(\omega/\omega_\alpha)^2$ against $I_\alpha/\pi\rho b^4$ for single-degree-of-freedom pitching oscillation for various axis-of-rotation positions a for several Mach numbers.

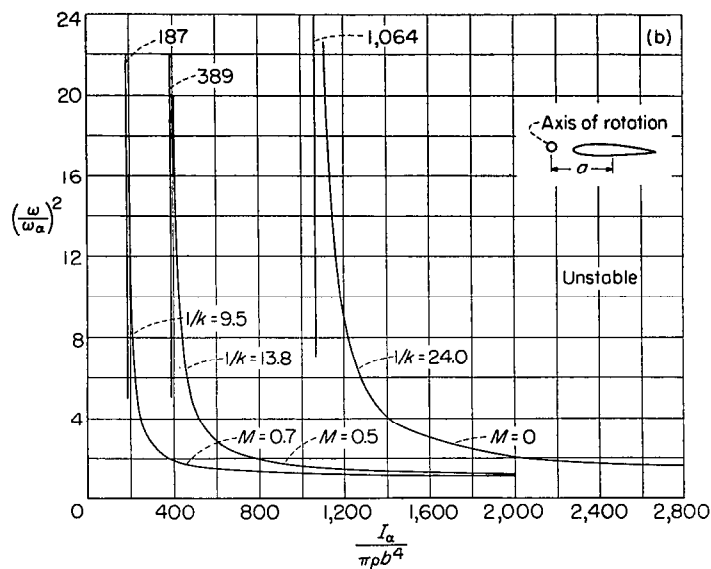

(b) $a = -1.5$.

FIGURE 2.—Continued.

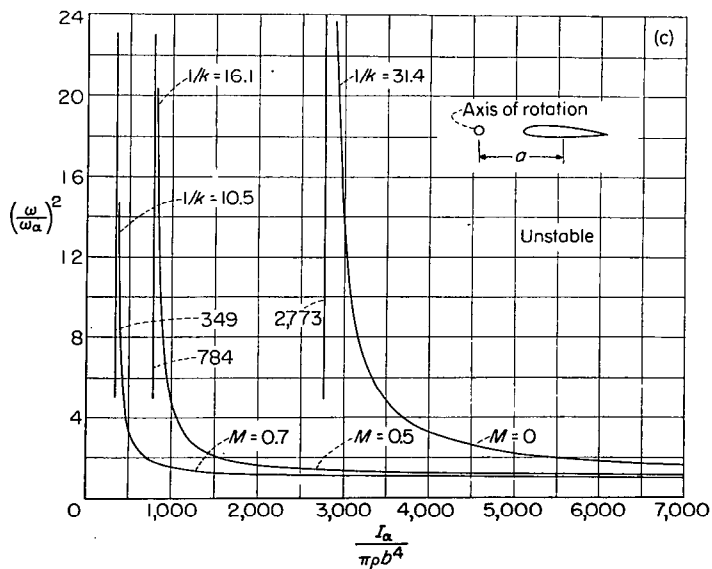

(c) $a = -2.0$.

FIGURE 2.—Continued.

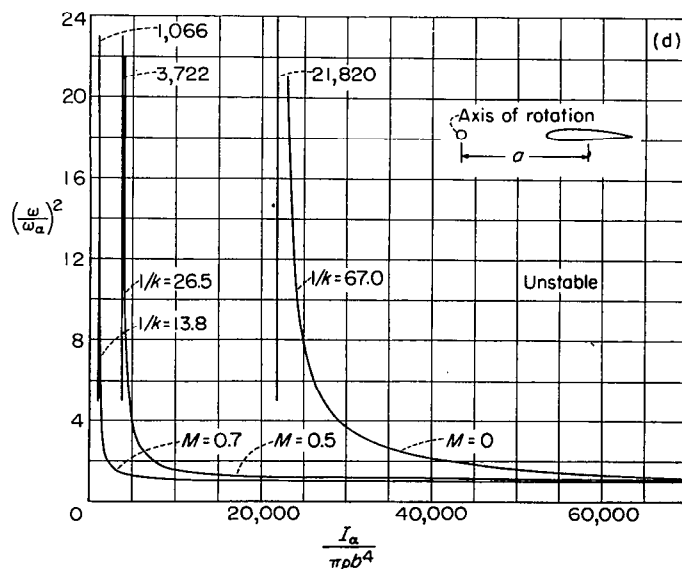

(d) $a = -3.0$.

FIGURE 2.—Continued.

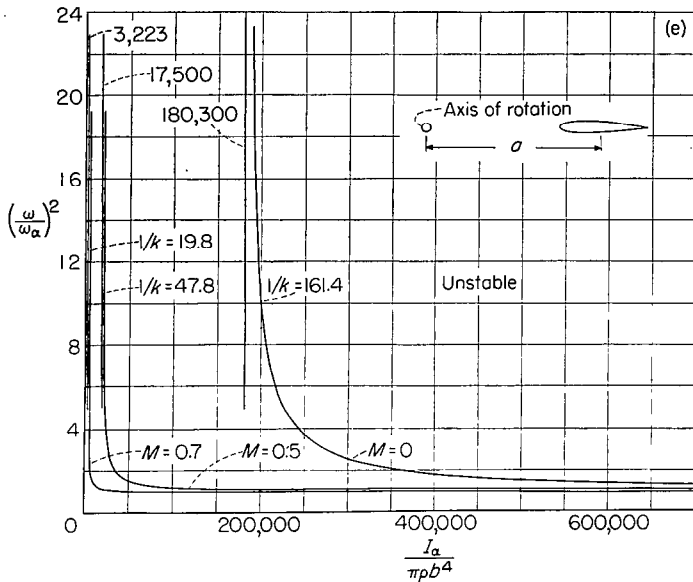

(e) $a = -4.0$.
FIGURE 2.—Continued.

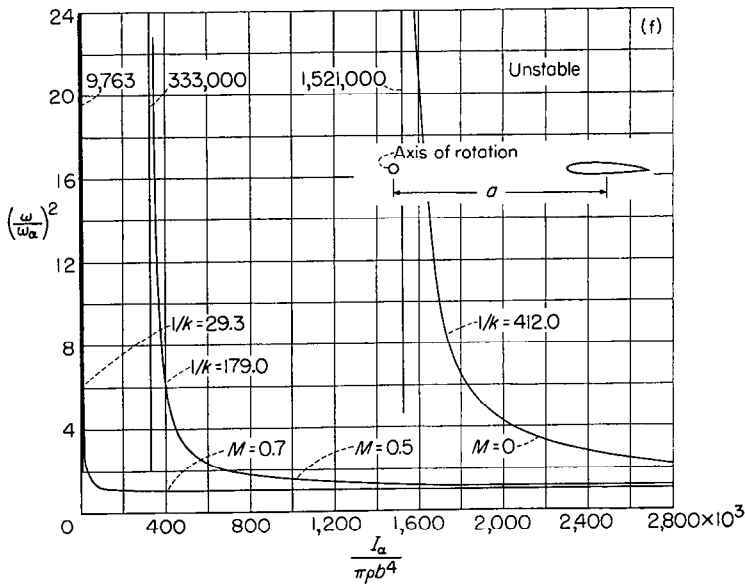

(f) $a = -5.0$.
FIGURE 2.—Concluded.

In figure 4, the value of reduced velocity $1/k$ is plotted against location of axis of rotation a for three Mach numbers. The area inside the curve for a given Mach number is the unstable region. The lower branch of each curve is asymptotic to $a = -0.5$ (quarter chord), but the upper branch has a maximum depending on the Mach number. For $M = 0$, corresponding to the results of reference 4, and for $M = 0.5$ the maximum value of a appears to be approximately -5.5 ; for $M = 0.7$ the maximum value of a is approximately -7 .

It should be noted that, for an airplane or missile having a comparatively short tail length (corresponding to the values

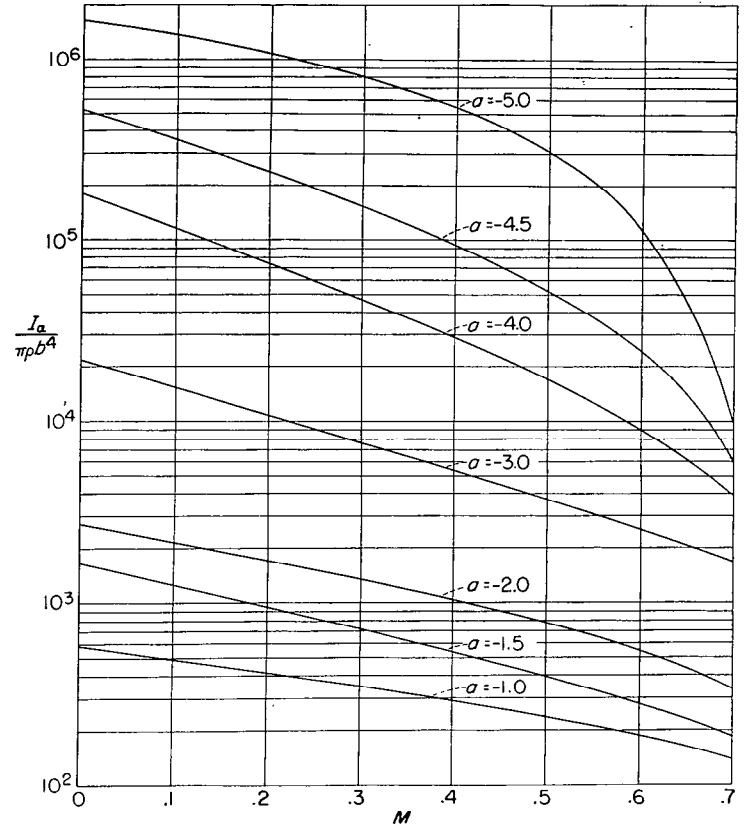

FIGURE 3.—Plot of asymptotic value of inertia parameter against Mach number for various axis-of-rotation locations a .

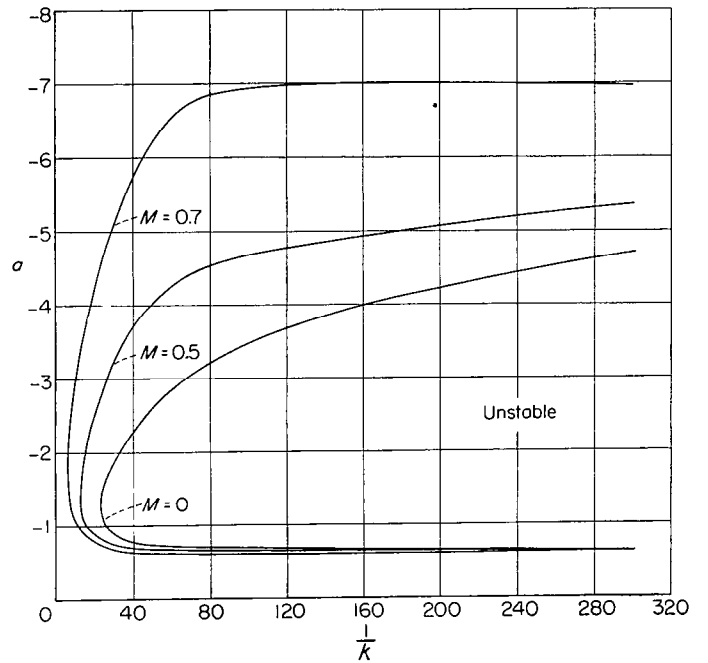

FIGURE 4.—Plot of axis-of-rotation location a against reduced frequency $1/k$ for three Mach numbers for single-degree-of-freedom pitching flutter.

of a in this report), an oscillation involving a yawing motion of the vertical tail or a pitching motion of the horizontal tail may be an instability of the type considered in this report. As a point of interest, values of the inertia parameter for usual aircraft configurations when the vertical tail is considered as the lifting surface vary from 2,000 to 20,000 at sea level and would be increased by a factor of 10 for 60,000 feet. Since the inertia of an aircraft is usually larger about the vertical axis than about the horizontal axis, it appears that this type of analysis might be more applicable to the yawing motion. It should be noted that the calculations are based on two-dimensional aerodynamic coefficients and the effect of aspect ratio, especially if a tail surface is considered, can be appreciable.

In figure 5, the effect of structural damping is shown for an axis-of-rotation location $a = -1.24$ and $M = 0$. The flutter-speed parameter $v/b\omega_\alpha$ is plotted against the inertia parameter for several values of structural damping coefficient g_α . It is apparent that a small amount of structural damping has a very great effect on the flutter speed, especially at the low density or high-altitude portion of the figure.

For instance, at a value of $\frac{I_\alpha}{\pi\rho b^4} = 18,000$, a value of $g_\alpha = 0.01$ raises the flutter velocity by a factor of 3 above the zero-damping curve, and a value of $g_\alpha = 0.02$ raises the flutter velocity by a factor of 5. However, structural damping did not influence the minimum (asymptotic) value of the inertia parameter at which the oscillation could begin.

APPARATUS AND TEST PROCEDURE

The tests were conducted in the Langley 4.5-foot flutter research tunnel at low speeds ($0.06 < M < 0.3$). This tunnel can be operated at any pressure from atmospheric to 1/2 inch of mercury to provide a large range of the inertia parameter $I_\alpha/\pi\rho b^4$.

A diagram of the model and test section is shown in figure 6 with all the pertinent dimensions and parameters. The geometric aspect ratio was 5.87. Since the wing tips were mounted close to the tunnel walls, an effective aspect ratio somewhat larger than the geometric aspect ratio was probably obtained. The wing was pivoted on ball bearings, and coil springs were fastened to the arms to provide structural restraint.

A small lever was inserted through the tunnel wall and sealed with rubber tubing so that the wing could be disturbed while the test was being conducted. It was found while conducting the tests that the oscillation could be started at a slightly lower fluid velocity if the wing were disturbed by means of the lever than if the wing were not disturbed. After the completion of the tests, the damping characteristics of the bearings were investigated, and it was found that the damping g_α was considerably greater for low-amplitude

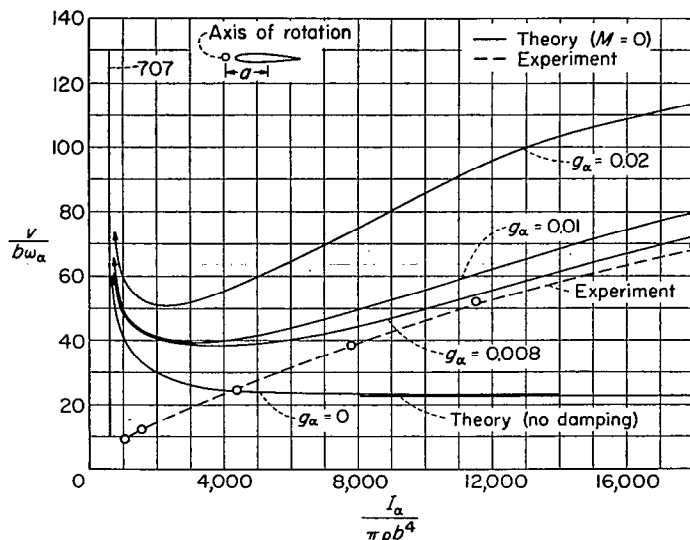

FIGURE 5.—Curves of experimental and theoretical single-degree-of-freedom pitching oscillation for various values of structural damping. $a = -1.24$.

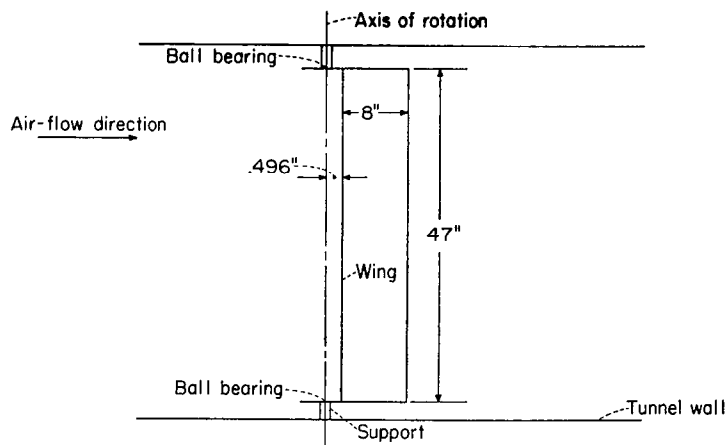

FIGURE 6.—Diagram of model and model installation. Inertia of system about axis of rotation $I_\alpha = 0.0948$ foot-pound-seconds square per foot; natural frequency of system $\omega_\alpha = 22.99$.

oscillations than for the high-amplitude oscillations. This variation of damping with amplitude can account for the fact previously mentioned that the model would start oscillating at slightly lower airspeed if the model were disturbed with the lever than if it were left to the inherent air turbulence of the tunnel.

EXPERIMENTAL RESULTS

The experimental results are plotted in figure 5 where the ordinate is the flutter-speed coefficient $v/b\omega_\alpha$, and the abscissa is the inertia parameter $I_\alpha/\pi\rho b^4$. Theoretical curves for four different values of damping are given, and the experimental curve is shown.

The values of the experimental curve at the high-altitude (low-density) range are in close agreement with the theoretical

curve for $g_\alpha=0.008$. From an examination of the records, it appears that a damping coefficient of $0.015 > g_\alpha > 0.008$ was obtained; a more exact determination was not possible because of the dependence of the damping on the amplitude of oscillation.

The important facts to be noted are, first, that a single-degree-of-freedom oscillation was obtained and, second, that the trend in the lower-density region was of the same order of magnitude as that of the theoretical curves with damping. The reason for the discrepancy at the higher-density part of the plot is not known; a similar phenomenon has been found in other cases for the more conventional type of flutter involving more than one degree of freedom.

From observations of the tests, it appears that the single-degree-of-freedom oscillation discussed in this report is a mild type of flutter, as contrasted to the more destructive type of flutter usually associated with coupled flutter. This type of instability might become of importance in airplane stability considerations, and the possible application to phenomena such as snaking should not be overlooked. It must be realized that three-dimensional effects may exercise some modification of these results.

CONCLUSIONS

A study of single-degree-of-freedom pitching oscillations of a wing has been presented. This study includes the effects of Mach number and structural damping and is primarily an extension of a recent paper by Smilg, in which incompressible flow was considered. The actual existence of single-degree-of-freedom flutter was demonstrated by some low-speed tests of a wing, pivoted a short distance ahead of the leading edge with a geometric aspect ratio of 5.87.

The following conclusions may be drawn:

1. The existence of single-degree-of-freedom pitching oscillations has been experimentally demonstrated.
2. The experimental data are in close agreement with the theoretical values for high values of the inertia parameter. At low values of the inertia parameter, the experimental data are in poor agreement with the theory.

3. Structural damping g_α has an appreciable effect on this instability and increases the flutter speed.

4. The analytical results show that an increase of Mach number reduces the range of values of an inertia parameter for which a configuration would be stable. The results are based on two-dimensional coefficients and it is possible that aspect ratio could have a great effect.

5. The flutter seems to be of a mild variety, in that it would not necessarily cause structural failure, but the possible application to phenomena such as snaking for aircraft having a short tail length should not be overlooked.

LANGLEY AERONAUTICAL LABORATORY,
NATIONAL ADVISORY COMMITTEE FOR AERONAUTICS,
LANGLEY FIELD, VA., April 10, 1951.

REFERENCES

1. Glauert, H.: The Force and Moment on an Oscillating Aerofoil. R. & M. No. 1242, British A.R.C., 1929.
2. Possio, C.: L'Azione aerodinamica sul profilo oscillante alle velocità ultrasonore. Acta, Pont. Acad. Sci., vol. I., no. 11, 1937, pp. 93-106.
3. Garrick, I. E., and Rubinow, S. I.: Flutter and Oscillating Air-Force Calculations for an Airfoil in a Two-Dimensional Supersonic Flow. NACA Rep. 846, 1946. (Supersedes NACA TN 1158.)
4. Smilg, Benjamin: The Instability of Pitching Oscillations of an Airfoil in Subsonic Incompressible Potential Flow. Jour. Aero. Sci., vol. 16, no. 11, Nov. 1949, pp. 691-696.
5. Miles, John W.: Quasi-Stationary Thin Airfoil Theory. Jour. Aero. Sci. (Readers' Forum), vol. 16, no. 7, July 1949, p. 440.
6. Garrick, I. E.: Bending-Torsion Flutter Calculations Modified by Subsonic Compressibility Corrections. NACA Rep. 836, 1946. (Supersedes NACA TN 1034.)
7. Theodorsen, Theodore, and Garrick, I. E.: Mechanism of Flutter—A Theoretical and Experimental Investigation of the Flutter Problem. NACA Rep. 685, 1940.
8. Smilg, Benjamin, and Wasserman, Lee S.: Application of Three-Dimensional Flutter Theory to Aircraft Structures. ACTR No. 4798, Materiel Div., Army Air Corps, July 9, 1942.