

**CASE FILE
COPY**

**NATIONAL ADVISORY COMMITTEE
FOR AERONAUTICS**

REPORT 1195

**FORMULAS FOR THE ELASTIC CONSTANTS OF PLATES
WITH INTEGRAL WAFFLE-LIKE STIFFENING**

By NORRIS F. DOW, CHARLES LIBOVE, and RALPH E. HUBKA



1954

REPORT 1195

**FORMULAS FOR THE ELASTIC CONSTANTS OF PLATES
WITH INTEGRAL WAFFLE-LIKE STIFFENING**

By NORRIS F. DOW, CHARLES LIBOVE, and RALPH E. HUBKA

**Langley Aeronautical Laboratory
Langley Field, Va.**

National Advisory Committee for Aeronautics

Headquarters, 1512 H Street NW., Washington 25, D. C.

Created by act of Congress approved March 3, 1915, for the supervision and direction of the scientific study of the problems of flight (U. S. Code, title 50, sec. 151). Its membership was increased from 12 to 15 by act approved March 2, 1929, and to 17 by act approved May 25, 1948. The members are appointed by the President, and serve as such without compensation.

JEROME C. HUNSAKER, Sc. D., Massachusetts Institute of Technology, *Chairman*

DETLEV W. BRONK, Ph. D., President, Rockefeller Institute for Medical Research, *Vice Chairman*

JOSEPH P. ADAMS, LL. D., member, Civil Aeronautics Board.
ALLEN V. ASTIN, Ph. D., Director, National Bureau of Standards.
PRESTON R. BASSETT, M. A., President, Sperry Gyroscope Co., Inc.
LEONARD CARMICHAEL, Ph. D., Secretary, Smithsonian Institution.
RALPH S. DAMON, D. Eng., President, Trans World Airlines, Inc.
JAMES H. DOOLITTLE, Sc. D., Vice President, Shell Oil Co.
LLOYD HARRISON, Rear Admiral, United States Navy, Deputy and Assistant Chief of the Bureau of Aeronautics.
RONALD M. HAZEN, B. S., Director of Engineering, Allison Division, General Motors Corp.

RALPH A. OFSTIE, Vice Admiral, United States Navy, Deputy Chief of Naval Operations (Air).
DONALD L. PUTT, Lieutenant General, United States Air Force, Deputy Chief of Staff (Development).
DONALD A. QUARLES, D. Eng., Assistant Secretary of Defense (Research and Development).
ARTHUR E. RAYMOND, Sc. D., Vice President—Engineering, Douglas Aircraft Co., Inc.
FRANCIS W. REICHELDERFER, Sc. D., Chief, United States Weather Bureau.
OSWALD RYAN, LL. D., member, Civil Aeronautics Board.
NATHAN F. TWINING, General, United States Air Force, Chief of Staff.

HUGH L. DRYDEN, Ph. D., *Director*

JOHN F. VICTORY, LL. D., *Executive Secretary*

JOHN W. CROWLEY, JR., B. S., *Associate Director for Research*

EDWARD H. CHAMBERLIN, *Executive Officer*

HENRY J. E. REID, D. Eng., Director, Langley Aeronautical Laboratory, Langley Field, Va.

SMITH J. DEFRANCE, D. Eng., Director, Ames Aeronautical Laboratory, Moffett Field, Calif.

EDWARD R. SHARP, Sc. D., Director, Lewis Flight Propulsion Laboratory, Cleveland Airport, Cleveland, Ohio

LANGLEY AERONAUTICAL LABORATORY
Langley Field, Va.

AMES AERONAUTICAL LABORATORY
Moffett Field, Calif.

LEWIS FLIGHT PROPULSION LABORATORY
Cleveland Airport, Cleveland, Ohio

Conduct, under unified control, for all agencies, of scientific research on the fundamental problems of flight

REPORT 1195

FORMULAS FOR THE ELASTIC CONSTANTS OF PLATES WITH INTEGRAL WAFFLE-LIKE STIFFENING¹

By NORRIS F. DOW, CHARLES LIBOVE, and RALPH E. HUBKA

SUMMARY

Formulas are derived for the fifteen elastic constants associated with bending, stretching, twisting, and shearing of plates with closely spaced integral ribbing in a variety of configurations and proportions. In the derivation the plates are considered, conceptually, as more uniform orthotropic plates somewhat on the order of plywood. The constants, which include the effectiveness of the ribs for resisting deformations other than bending and stretching in their longitudinal directions, are defined in terms of four coefficients α , β , α' , and β' , and theoretical and experimental methods for the evaluation of these coefficients are discussed. Four of the more important elastic constants are predicted by these formulas and are compared with test results. Good correlation is obtained.

INTRODUCTION

Growing interest in integrally stiffened construction, evidenced by such papers as references 1 and 2 and by the large forging press program (ref. 3) and the chemical milling process (ref. 4) which will provide facilities for production, emphasizes the need for information on the structural characteristics of integrally stiffened plates.

A primary requisite for the prediction of structural characteristics of plates is a knowledge of their elastic constants. In the present report, therefore, formulas are derived for the fifteen elastic constants associated with the bending, stretching, twisting, and shearing of plates with closely spaced integral ribs running in one or more directions. The ribbing patterns covered by the formulas are illustrated in figure 1 and include those considered in reference 5. The rib cross section is arbitrary, although special auxiliary formulas are given for the rectangular-section rib with circular fillets at its base.

The elastic-constant formulas derived involve four coefficients α , β , α' , β' for each rib which define the effectiveness of the rib in resisting deformations other than simple bending or stretching in its longitudinal direction. For most purposes a reasonably accurate evaluation of these coefficients is required. Experimental and theoretical methods of evaluating them are discussed.

As a check on the correctness of the elastic-constant formulas, the predictions of the formulas for four of the more important elastic constants are compared with experimental data.

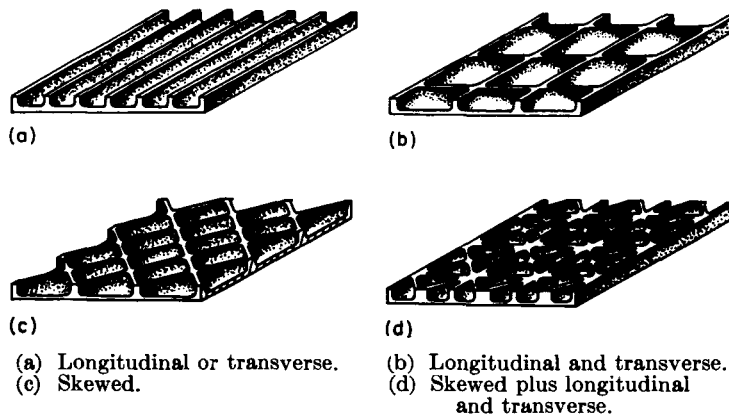

FIGURE 1.—Ribbing configurations considered.

SYMBOLS

Plane I is defined as the plane in which N_x acts and in which ϵ_x is measured. Plane II is defined as the plane in which N_y acts and in which ϵ_y is measured. Plane III is defined as the plane in which N_{xy} acts and in which γ_{xy} is measured. These three planes are illustrated in figure 2.

GENERAL SYMBOLS

C_{xz}	} coupling elastic constants associated with bending and stretching and defined by the force-distortion equations (1), (2), (4), and (5), lb ⁻¹
C_{xy}	
C_{yz}	
C_{yy}	
C_{11}	} coupling elastic constants associated with bending and stretching and defined by the force-distortion equations (7), (8), (10), and (11), in.
C_{12}	
C_{21}	
C_{22}	
C_k	coupling elastic constant associated with twist and shear and defined by the force-distortion equations (9) and (12), in.
D_x, D_y	} bending stiffness in x - and y -directions, respectively, in-lb
D_1, D_2	
D_{xy}, D_k	twisting stiffnesses relative to x - and y -directions, in-lb
E	Young's modulus of material, psi
E_x, E_y	} extensional stiffnesses in x - and y -directions, respectively, lb/in.
E_1, E_2	
G	shear modulus of material, psi
G_{xy}	shear stiffness of plate in xy -plane, lb/in
M_x, M_y	resultant bending-moment intensity in x - and y -directions, respectively, lb

¹ Supersedes recently declassified NACA RM L53E13a, "Formulas for the Elastic Constants of Plates With Integral Waffle-Like Stiffening" by Norris F. Dow, Charles Libove, and Ralph E. Hubka, 1953.

M_{xy}	resultant twisting-moment intensity with regard to x - and y -directions, lb
N_x	intensity of resultant normal force acting in x -direction in plane I, lb/in.
N_y	intensity of resultant normal force acting in y -direction in plane II, lb/in.
N_{xy}	intensity of resultant shear force acting in x - and y -directions in plane III, lb/in.
s	coordinate, measured parallel to skewed rib, in.
t	coordinate, measured perpendicular to skewed rib, in.
T	coupling elastic constant associated with twist and shear and defined by the force-distortion equations (3) and (6), lb^{-1}
w	displacement in z -direction, in.
U, V	strain energy, in-lb
x	coordinate, measured in longitudinal direction, in.
y	coordinate, measured in transverse direction, in.
z	coordinate, measured perpendicular to faces of skin, in.
γ_{xy}	shear strain, with respect to x - and y -directions, of plane III
ϵ_x, ϵ_y	strain of plane I in x -direction and of plane II in y -direction, respectively
μ	Poisson's ratio for material
μ_x, μ_y	Poisson's ratios associated with bending in x - and y -directions, respectively, and defined by the force-distortion equations (1), (2), (7), and (8)
μ'_x, μ'_y μ_1, μ_2	Poisson's ratios associated with extension in x - and y -directions, respectively, and defined by the force-distortion equations (4), (5), (10), and (11)

SYMBOLS REPRESENTING DIMENSIONS

b_x, b_y	x -wise and y -wise length, respectively, of smallest repeating unit of plate, in.
b_s	spacing of skew ribs, equal to $b_x/\sin \theta$ or $b_y/\cos \theta$, in.
b_s	rib spacing (measured between center lines of parallel ribs), in.
b_w	rib depth, $H - t_s$, in.
d	diameter of largest circle that can be inscribed in cross section at intersection of rib and skin, in.
h, k	distance from planes of zero strain to rib centroids, in.
H	overall height of rib plus skin, in.
r_w	radius of fillet, in.
R_w	corner radius, in.
t	thickness, in.
\bar{t}	average or equivalent thickness, in.
θ	angle of skewed ribbing, measured from the longitudinal direction, deg

SYMBOLS USED IN EQUATIONS FOR ELASTIC CONSTANTS

a	constant used in equations for calculating α'_{UL}
$A_{w_x}, A_{w_y}, A_{w_s}$	cross-sectional area (including fillets) of x -wise, y -wise, and skewed ribs (A_{w_s} includes area of two ribs), sq in.
A_w f, g, h	general symbol for A_{w_x}, A_{w_y} , or A_{w_s} , constants used in equations for calculating α_{UL} and β_{UL}
$I_{w_x}, I_{w_y}, I_{w_s}$	cross-sectional moment of inertia of x -wise, y -wise, or skewed ribs about their centroids (I_{w_s} is twice the moment of inertia of a single skew rib), in.^4
k_I, k_{II}, k_{III}	dimensionless distance from middle surface of sheet to planes I, II, and III, respectively, expressed as fractions of the overall height H
$\bar{k}_{w_x}, \bar{k}_{w_y}, \bar{k}_{w_s}$	dimensionless distance from middle surface of sheet to centroid of x -wise, y -wise, or skewed rib, expressed as a fraction of the overall height H
$\alpha_{LL}, \alpha_{exp}, \alpha_{UL}$ $\alpha_x, \alpha_y, \alpha_s$	constants used to locate the effective centroid of a rib for resisting bending in its transverse direction
α	general symbol representing α_x, α_y , or α_s
$\alpha'_x, \alpha'_y, \alpha'_s$	constants used to locate the effective centroid of a rib for resisting twisting
α'	general symbol representing α'_x, α'_y , or α'_s
$\beta_{LL}, \beta_{exp}, \beta_{UL}$ $\beta_x, \beta_y, \beta_s$	constants used to define effectiveness of a rib in resisting stretching in its transverse direction
β	general symbol representing β_x, β_y , or β_s
$\beta'_x, \beta'_y, \beta'_s$	constants used to define effectiveness of a rib in resisting shearing
β'	general symbol representing β'_x, β'_y , or β'_s
SUBSCRIPTS	
L	longitudinal
S	sheet or skin
T	transverse
W	rib (web)
s, x, y	indicate application to skewed, x -wise, or y -wise ribs or directions
LL	lower limit
UL	upper limit
exp	experimental

DEFINITION OF ELASTIC CONSTANTS

If the rib spacings of integrally stiffened plates such as those shown in figure 1 are small in comparison with the plate width and length, it is plausible, for purposes of studying overall or average behavior, to assume that the actual plate may be replaced by an equivalent uniform orthotropic plate. Figure 2 shows an infinitesimal element of the equivalent plate subjected to bending moments of intensity M_x and M_y , twisting moments of intensity M_{xy} , stretching forces of intensity N_x and N_y acting in planes I and II, respectively, and shearing forces of intensity N_{xy} in plane III. The locations of planes I, II, and III are arbitrary.

The behavior of the element can be described by a set of force-distortion relationships in which elastic constants appear. Such relationships for special rectangular orthotropic plates having their axes of principal stiffness parallel and perpendicular to their edges, as considered herein, are obtainable from reference 6. If deflections due to depthwise shear are assumed to be negligible as is customary in ordinary plate theory, the following equations (eqs. (1') to (6') of ref. 6) are obtained:

$$\frac{\partial^2 w}{\partial x^2} = -\frac{M_x}{D_x} + \frac{\mu_y}{D_y} M_y + C_{xz} N_x + C_{zy} N_y \quad (1)$$

$$\frac{\partial^2 w}{\partial y^2} = \frac{\mu_x}{D_x} M_x - \frac{M_y}{D_y} + C_{yx} N_x + C_{yy} N_y \quad (2)$$

$$\frac{\partial^2 w}{\partial x \partial y} = \frac{M_{xy}}{D_{xy}} + T N_{xy} \quad (3)$$

$$\epsilon_x = -C_{xx} M_x - C_{yx} M_y + \frac{N_x}{E_x} - \frac{\mu'_y}{E_y} N_y \quad (4)$$

$$\epsilon_y = -C_{xy} M_x - C_{yy} M_y - \frac{\mu'_x}{E_x} N_x + \frac{N_y}{E_y} \quad (5)$$

$$\gamma_{xy} = 2T M_{xy} + \frac{N_{xy}}{G_{xy}} \quad (6)$$

where $\frac{\partial^2 w}{\partial x^2}$ and $\frac{\partial^2 w}{\partial y^2}$ are the curvatures, $\frac{\partial^2 w}{\partial x \partial y}$ is the twist, ϵ_x and ϵ_y are the extensional strains in planes I and II, respectively, and γ_{xy} is the shear strain in plane III.

According to these equations, fifteen constants are needed to establish the force-distortion relationships—namely, two bending stiffnesses D_x and D_y , a twisting stiffness D_{xy} , two stretching moduli E_x and E_y , a shearing modulus G_{xy} , two Poisson's ratios μ_x and μ_y associated with bending, two Poisson's ratios μ'_x and μ'_y associated with stretching, four coupling terms C_{xx} , C_{yy} , C_{yx} , and C_{xy} associated with bending and stretching, and one coupling term T associated with twisting and shear. Not all these constants are independent, however; for example, as a consequence of the reciprocity theorem for elastic structures, $\mu_y = D_y \mu_x / D_x$ and $\mu'_y = E_y \mu'_x / E_x$.

The form in which the force-distortion relationships have just been given is not the most convenient form for some applications, particularly for buckling calculations. For such purposes a more suitable form is obtained when the

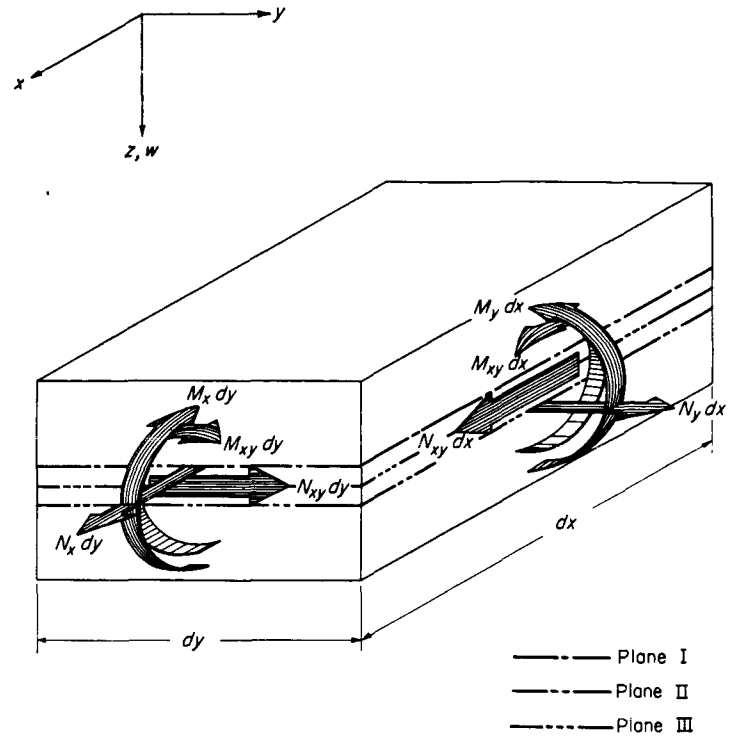

FIGURE 2.—Forces and moments acting on element.

first three equations are solved simultaneously for M_x , M_y , and M_{xy} and these expressions are then used to eliminate M_x , M_y , and M_{xy} in the last three equations. The six new force-distortion equations thus obtained are

$$M_x = -D_1 \left(\frac{\partial^2 w}{\partial x^2} + \mu_y \frac{\partial^2 w}{\partial y^2} \right) + C_{11} N_x + C_{12} N_y \quad (7)$$

$$M_y = -D_2 \left(\frac{\partial^2 w}{\partial y^2} + \mu_x \frac{\partial^2 w}{\partial x^2} \right) + C_{21} N_x + C_{22} N_y \quad (8)$$

$$M_{xy} = 2D_k \frac{\partial^2 w}{\partial x \partial y} + C_k N_{xy} \quad (9)$$

$$\epsilon_x = C_{11} \frac{\partial^2 w}{\partial x^2} + C_{21} \frac{\partial^2 w}{\partial y^2} + \frac{N_x}{E_1} - \frac{\mu_2}{E_2} N_y \quad (10)$$

$$\epsilon_y = C_{12} \frac{\partial^2 w}{\partial x^2} + C_{22} \frac{\partial^2 w}{\partial y^2} - \frac{\mu_1}{E_1} N_x + \frac{N_y}{E_2} \quad (11)$$

$$\gamma_{xy} = -2C_k \frac{\partial^2 w}{\partial x \partial y} + \frac{N_{xy}}{G_k} \quad (12)$$

where $\mu_y = D_2 \mu_x / D_1$ and $\mu_2 = E_2 \mu_1 / E_1$.

Of the fifteen elastic constants appearing in equations (7) to (12), two, μ_x and μ_y , were also in the original set of force-distortion equations. The remaining constants (D_1 , D_2 , D_k , E_1 , E_2 , G_k , μ_1 , μ_2 , C_{11} , C_{12} , C_{21} , C_{22} , and C_k) are "new." The algebraic relationships between the new and the original elastic constants are given in appendix A.

METHOD OF ANALYSIS

The analysis is made for a plate with the general pattern of ribbing shown in figure 3 (a), which includes, as special cases, the patterns of figure 1. A typical repeating element of the

plate is indicated by the short-dashed rectangle in figure 3 (a) and is shown three-dimensionally in figure 3 (b).

The analysis is based on the assumption that each of the four rib segments shown in figure 3 (b) may be replaced by three orthotropic sheets of material parallel to the skin, each one covering the entire area $b_x b_y$ and each fastened to the skin by means of many hypothetical, perfectly rigid, infinitesimally small bars imbedded perpendicularly through the skin and sheets (see fig. 4). The substitute sheets are assumed to offer no interference to one another. (The rib is understood to include any fillet material but no part of the skin.) The properties of the three substitute sheets are so chosen that

one sheet (labeled ① in fig. 4) represents only the effectiveness of the rib in resisting stretching and bending in its longitudinal direction, another (labeled ②) represents only the effectiveness of the rib in resisting stretching and bending in its transverse direction, and the third (labeled ③) represents only the effectiveness of the rib in resisting shearing and twisting relative to its longitudinal and transverse directions. (The transverse direction, as used herein, is the direction in which t_w is measured, see fig. 3.) In order for the three substitute sheets to accomplish their purpose, they are assigned the following properties:

(a) Sheet ① has a volume equal to that of the rib segment it replaces, with its center of gravity at the same level as that of the rib. Its stretching or compressing modulus of elasticity in the direction of the rib is E and its modulus transverse to the rib is zero. Its stiffness per unit width for bending in the direction of the rib is equal to the bending stiffness of the rib about its centroid divided by the rib spacing (i.e., b_x for a y -wise rib, b_y for an x -wise rib, and b_s for a skew rib, fig. 3(a)), whereas its bending stiffness in the direction transverse to the rib is zero. The shearing and twisting stiffnesses and Poisson's ratios of the sheet are assumed to be zero.

(b) Sheet ② has a volume equal to some fraction β of the volume of the rib segment, with its center of gravity at some distance αH above the middle surface of the skin. The modulus of elasticity for stretching or compressing in the direction transverse to the rib is E , whereas that in the longitudinal direction of the rib is zero. The bending, shearing, and twisting stiffnesses, and Poisson's ratios for sheet ② are all assumed to be zero.

(c) Sheet ③ has a volume equal to some fraction β' of the volume of the rib segment, with its center of gravity at some distance $\alpha'H$ above the middle surface of the skin. Its modulus of elasticity for shearing relative to the longitudinal and transverse directions of the rib is G , whereas its twisting stiffness relative to these two directions is zero, as are the stretching and bending stiffnesses and Poisson's ratios.

On the basis of the foregoing assumptions, the integrally stiffened plate has been converted to a more homogeneous plate somewhat on the order of plywood. The assumption of rigid bars connecting the substitute sheets and the skin

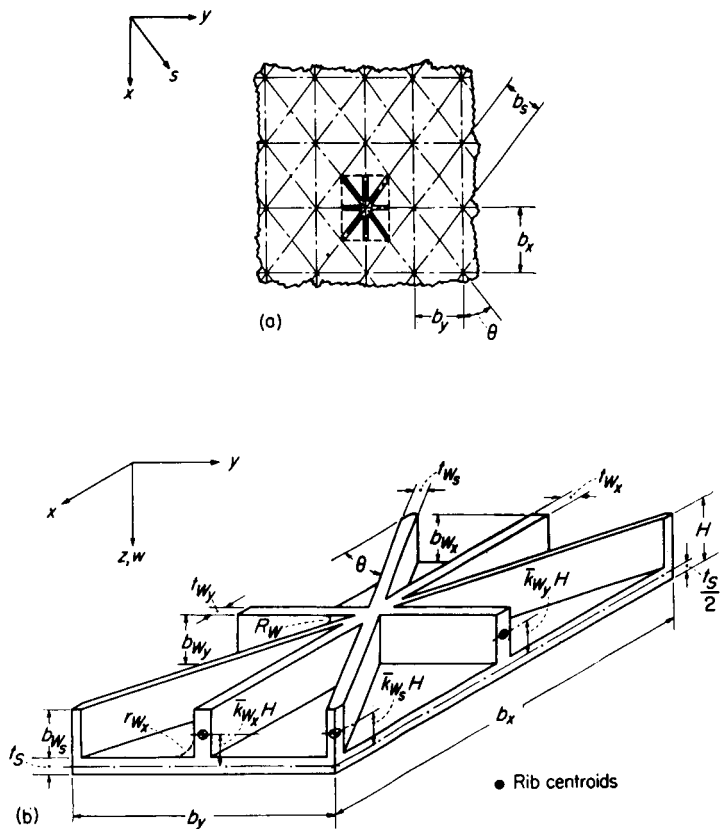

(a) Most general pattern of ribbing considered. (Short-dashed lines enclose typical element.)

(b) Three-dimensional view of typical element.

FIGURE 3.—Repeating element of plate with integral, waffle-like stiffening.

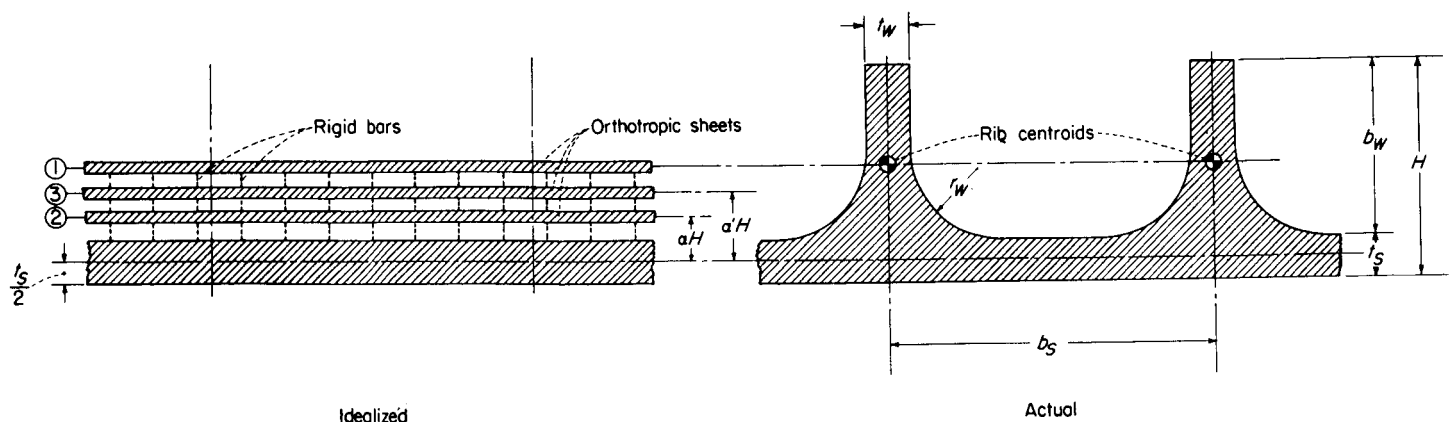

FIGURE 4.—Comparison of idealized and actual rib-skin combinations.

is equivalent to the assumption that material lines normal to the surface of the plate before deformation remain straight during deformation. If it is further assumed that these lines remain perpendicular to the surface of the plate and that the stresses are in the elastic range, any of the methods used for ordinary isotropic plate analysis may be readily extended to the present idealized structure.

For the present purpose an energy method is adopted to determine the six forces and moments necessary to maintain the prescribed uniform deformations $\frac{\partial^2 w}{\partial x^2}$, $\frac{\partial^2 w}{\partial y^2}$, ϵ_x , ϵ_y , $\frac{\partial^2 w}{\partial x \partial y}$, and γ_{xy} . The equations obtained for these forces and moments in terms of the distortions are put in the form of equations (1) to (6) to yield formulas for the original elastic constants or in the form of equations (7) to (12) to yield formulas for the new elastic constants.

The details of the analysis and the derivation of the elastic constants are presented in appendix B. The formulas obtained for these constants are presented in the following section and the evaluation of α , β , α' , and β' is discussed in two succeeding sections.

FORMULAS FOR ELASTIC CONSTANTS

In this section the formulas are presented for the calculation of the fifteen elastic constants appearing in equations (1) to (6) and the thirteen new constants appearing in equations (7) to (12). The formulas are presented for the most general type of plate considered, which is illustrated in figure 3. For plates with one or more sets of ribs omitted, the formulas also apply when the terms representing the areas and moments of inertia of the omitted ribs are set equal to zero.

The formulas for the constants in the original force-distortion equations (1) to (6) are as follows:

$$D_x = EH^3 \left[I_x - \frac{A_s^2 A_x}{\bar{A}_s^2} (\bar{k}_x - \bar{k}_s)^2 - \mu_x \left(\frac{\bar{I}_s^2}{\bar{A}_s^2} \right) \right] \quad (13)$$

$$D_y = EH^3 \left[I_y - \frac{A_s^2 A_y}{\bar{A}_s^2} (\bar{k}_y - \bar{k}_s)^2 - \mu_y \left(\frac{\bar{I}_s^2}{\bar{A}_s^2} \right) \right] \quad (14)$$

$$D_{xy} = EH^3 \left(\frac{I_{xy}}{2} \right) \quad (15)$$

$$E_x = EH \left\{ \frac{\bar{A}_s^2 (I_x I_y - I_s^2) - A_s^2 A_x A_y (\bar{k}_x - \bar{k}_s)^2 (\bar{k}_y - \bar{k}_s)^2 - A_s^2 \left[A_x I_y (\bar{k}_x - \bar{k}_s)^2 + 2 \frac{A_x A_y}{A_s} I_s (\bar{k}_x - \bar{k}_s) (\bar{k}_y - \bar{k}_s) + A_y I_x (\bar{k}_y - \bar{k}_s)^2 \right]}{A_y (I_x I_y - I_s^2) + A_x A_y I_y (\bar{k}_x - k_{I1})^2 - A_s (\bar{k}_s - k_{I1}) \left[A_s I_y (\bar{k}_s - k_{I1}) - 2 A_y I_s (\bar{k}_y - \bar{k}_s) + A_s A_y (\bar{k}_s - k_{I1}) (\bar{k}_y - \bar{k}_s)^2 \right]} \right\} \quad (16)$$

$$E_y = EH \left\{ \frac{\bar{A}_s^2 (I_x I_y - I_s^2) - A_s^2 A_x A_y (\bar{k}_x - \bar{k}_s)^2 (\bar{k}_y - \bar{k}_s)^2 - A_s^2 \left[A_x I_y (\bar{k}_x - \bar{k}_s)^2 + 2 \frac{A_x A_y}{A_s} I_s (\bar{k}_x - \bar{k}_s) (\bar{k}_y - \bar{k}_s) + A_y I_x (\bar{k}_y - \bar{k}_s)^2 \right]}{A_x (I_x I_y - I_s^2) + A_x A_y I_x (\bar{k}_y - k_{II})^2 - A_s (\bar{k}_s - k_{II}) \left[A_s I_x (\bar{k}_s - k_{II}) - 2 A_x I_s (\bar{k}_x - \bar{k}_s) + A_s A_x (\bar{k}_s - k_{II}) (\bar{k}_x - \bar{k}_s)^2 \right]} \right\} \quad (17)$$

$$G_{xy} = EH \left[\frac{A_{xy} I_{xy}}{I_{xy} + 4 A_{xy} (\bar{k}_{xy} - k_{III})^2} \right] \quad (18)$$

$$\mu_x = \frac{\bar{I}_s^2}{I_y \bar{A}_s^2 - A_s^2 A_y (\bar{k}_y - \bar{k}_s)^2} \quad (19)$$

$$\mu_y = \frac{\bar{I}_s^2}{I_x \bar{A}_s^2 - A_s^2 A_x (\bar{k}_x - \bar{k}_s)^2} \quad (20)$$

$$\mu'_x = \frac{\left\{ \begin{array}{l} A_s (I_x I_y - I_s^2) + A_s A_x I_y (\bar{k}_x - k_{I1}) (\bar{k}_x - \bar{k}_s) + A_s A_y I_x (\bar{k}_y - k_{II}) (\bar{k}_y - \bar{k}_s) + A_x A_y I_s (\bar{k}_x - k_{I1}) (\bar{k}_y - k_{II}) - \\ A_s^2 I_s (\bar{k}_s - k_{I1}) (\bar{k}_s - k_{II}) + A_s A_x A_y (\bar{k}_x - k_{I1}) (\bar{k}_y - k_{II}) (\bar{k}_x - \bar{k}_s) (\bar{k}_y - \bar{k}_s) \end{array} \right\}}{A_y (I_x I_y - I_s^2) + A_x A_y I_y (\bar{k}_x - k_{I1})^2 - A_s (\bar{k}_s - k_{I1}) \left[A_s I_y (\bar{k}_s - k_{I1}) - 2 A_y I_s (\bar{k}_y - \bar{k}_s) + A_s A_y (\bar{k}_s - k_{I1}) (\bar{k}_y - \bar{k}_s)^2 \right]} \quad (21)$$

$$\mu'_y = \frac{\left\{ \begin{array}{l} A_s (I_x I_y - I_s^2) + A_s A_x I_y (\bar{k}_x - k_{I1}) (\bar{k}_x - \bar{k}_s) + A_s A_y I_x (\bar{k}_y - k_{II}) (\bar{k}_y - \bar{k}_s) + A_x A_y I_s (\bar{k}_x - k_{I1}) (\bar{k}_y - k_{II}) - \\ A_s^2 I_s (\bar{k}_s - k_{I1}) (\bar{k}_s - k_{II}) + A_s A_x A_y (\bar{k}_x - k_{I1}) (\bar{k}_y - k_{II}) (\bar{k}_x - \bar{k}_s) (\bar{k}_y - \bar{k}_s) \end{array} \right\}}{A_x (I_x I_y - I_s^2) + A_x A_y I_x (\bar{k}_y - k_{II})^2 - A_s (\bar{k}_s - k_{II}) \left[A_s I_x (\bar{k}_s - k_{II}) - 2 A_x I_s (\bar{k}_x - \bar{k}_s) + A_s A_x (\bar{k}_s - k_{II}) (\bar{k}_x - \bar{k}_s)^2 \right]} \quad (22)$$

$$C_{xx} = \frac{1}{EH^2} \left[\frac{k_{I1} - \frac{A_x A_y \bar{k}_x - A_s^2 \bar{k}_s}{\bar{A}_s^2} - \mu_x \frac{A_s A_y (\bar{k}_y - \bar{k}_s)}{\bar{A}_s^2}}{I_x - \frac{A_s^2 A_x}{\bar{A}_s^2} (\bar{k}_x - \bar{k}_s)^2 - \mu_x \left(\frac{\bar{I}_s^2}{\bar{A}_s^2} \right)} \right] \quad (23)$$

$$C_{xz} = \frac{1}{EH^2} \left[\frac{A_s A_x (\bar{k}_x - \bar{k}_s) - \mu_z \left(k_{11} - \frac{A_x A_y \bar{k}_y - A_s^2 \bar{k}_s}{\bar{A}_s^2} \right)}{\bar{A}_s^2} \right. \\ \left. \frac{I_x - \frac{A_s^2 A_x}{\bar{A}_s^2} (\bar{k}_x - \bar{k}_s)^2 - \mu_x \left(\frac{\bar{I}_s^2}{\bar{A}_s^2} \right)}{\bar{A}_s^2} \right] \quad (24)$$

$$C_{yx} = \frac{1}{EH^2} \left[\frac{A_s A_y (\bar{k}_y - \bar{k}_s) - \mu_y \left(k_{11} - \frac{A_x A_y \bar{k}_x - A_s^2 \bar{k}_s}{\bar{A}_s^2} \right)}{\bar{A}_s^2} \right. \\ \left. \frac{I_y - \frac{A_s^2 A_y}{\bar{A}_s^2} (\bar{k}_y - \bar{k}_s)^2 - \mu_y \left(\frac{\bar{I}_s^2}{\bar{A}_s^2} \right)}{\bar{A}_s^2} \right] \quad (25)$$

$$C_{yy} = \frac{1}{EH^2} \left[\frac{k_{11} - \frac{A_x A_y \bar{k}_y - A_s^2 \bar{k}_s}{\bar{A}_s^2} - \mu_y \frac{A_s A_x (\bar{k}_x - \bar{k}_s)}{\bar{A}_s^2}}{\bar{A}_s^2} \right. \\ \left. \frac{I_y - \frac{A_s^2 A_y}{\bar{A}_s^2} (\bar{k}_y - \bar{k}_s)^2 - \mu_y \left(\frac{\bar{I}_s^2}{\bar{A}_s^2} \right)}{\bar{A}_s^2} \right] \quad (26)$$

$$T = -\frac{1}{EH^2} \left[\frac{2(\bar{k}_{xy} - k_{11})}{I_{xy}} \right] \quad (27)$$

The formulas for the constants in the new equations (eqs. (7) to (12)) are as follows:

$$D_1 = EH^3 \left[I_x - \frac{A_s^2 A_x}{\bar{A}_s^2} (\bar{k}_x - \bar{k}_s)^2 \right] \quad (28)$$

$$D_2 = EH^3 \left[I_y - \frac{A_s^2 A_y}{\bar{A}_s^2} (\bar{k}_y - \bar{k}_s)^2 \right] \quad (29)$$

$$D_k = EH^3 \left(\frac{I_{xy}}{4} \right) \quad (30)$$

$$E_1 = EH \left(\frac{\bar{A}_s^2}{A_y} \right) \quad (31)$$

$$E_2 = EH \left(\frac{\bar{A}_s^2}{A_x} \right) \quad (32)$$

$$G_k = EH(A_{xy}) \quad (33)$$

$$\mu_1 = \frac{A_s}{A_y} \quad (34)$$

$$\mu_2 = \frac{A_s}{A_x} \quad (35)$$

$$C_{11} = H \left(k_{11} - \frac{A_x A_y \bar{k}_x - A_s^2 \bar{k}_s}{\bar{A}_s^2} \right) \quad (36)$$

$$C_{12} = H \left[\frac{A_s A_x (\bar{k}_x - \bar{k}_s)}{\bar{A}_s^2} \right] \quad (37)$$

$$C_{21} = H \left[\frac{A_s A_y (\bar{k}_y - \bar{k}_s)}{\bar{A}_s^2} \right] \quad (38)$$

$$C_{22} = H \left(k_{11} - \frac{A_x A_y \bar{k}_y - A_s^2 \bar{k}_s}{\bar{A}_s^2} \right) \quad (39)$$

$$C_k = H(\bar{k}_{xy} - k_{11}) \quad (40)$$

where

E Young's modulus of material, psi
 H overall height of skin plus ribs, in.

The quantities \bar{A}_s , \bar{I}_s , A_x , A_y , A_s , and A_{xy} , \bar{k}_x , \bar{k}_y , \bar{k}_s , and \bar{k}_{xy} , I_x , I_y , I_s , and I_{xy} appearing in equations (13) to (40) are defined by the following equations:

$$\bar{A}_s^2 = A_x A_y - A_s^2 \quad (41)$$

$$\bar{I}_s^2 = I_s \bar{A}_s^2 + A_s A_x A_y (\bar{k}_x - \bar{k}_s) (\bar{k}_y - \bar{k}_s) \quad (42)$$

$$A_x = \frac{1}{1-\mu^2} \frac{t_s}{H} + \frac{A_{w_x}/b_y}{H} + \beta_y \frac{A_{w_y}/b_x}{H} + \frac{A_{w_s}/b_s}{H} \left(\cos^4 \theta + \beta_s \sin^4 \theta + \right. \\ \left. \beta'_s \frac{2}{1+\mu} \sin^2 \theta \cos^2 \theta \right) \quad (43)$$

$$A_y = \frac{1}{1-\mu^2} \frac{t_s}{H} + \beta_x \frac{A_{w_x}/b_y}{H} + \frac{A_{w_y}/b_x}{H} + \frac{A_{w_s}/b_s}{H} \left(\sin^4 \theta + \beta_s \cos^4 \theta + \right. \\ \left. \beta'_s \frac{2}{1+\mu} \sin^2 \theta \cos^2 \theta \right) \quad (44)$$

$$A_s = \frac{\mu}{1-\mu^2} \frac{t_s}{H} + \frac{A_{w_s}/b_s}{H} \left(\sin^2 \theta \cos^2 \theta + \beta_s \sin^2 \theta \cos^2 \theta - \right. \\ \left. \beta'_s \frac{2}{1+\mu} \sin^2 \theta \cos^2 \theta \right) \quad (45)$$

$$A_{xy} = \frac{1}{2(1+\mu)} \frac{t_s}{H} + \beta'_x \frac{1}{2(1+\mu)} \frac{A_{w_x}/b_y}{H} + \beta'_y \frac{1}{2(1+\mu)} \frac{A_{w_y}/b_x}{H} + \\ \frac{A_{w_s}/b_s}{H} \left[\sin^2 \theta \cos^2 \theta + \beta_s \sin^2 \theta \cos^2 \theta + \beta'_s \frac{1}{2(1+\mu)} \cos^2 2\theta \right] \quad (46)$$

$$\bar{k}_x = \frac{1}{A_x} \left[\frac{A_{w_x}/b_y}{H} (\bar{k}_{w_x}) + \beta_y \frac{A_{w_y}/b_x}{H} (\alpha_y) + \frac{A_{w_s}/b_s}{H} \left(\bar{k}_{w_s} \cos^4 \theta + \right. \right. \\ \left. \left. \beta_s \alpha_s \sin^4 \theta + \beta'_s \alpha'_s \frac{2}{1+\mu} \sin^2 \theta \cos^2 \theta \right) \right] \quad (47)$$

$$\bar{k}_y = \frac{1}{A_y} \left[\beta_x \frac{A_{w_x}/b_y}{H} (\alpha_x) + \frac{A_{w_y}/b_x}{H} (\bar{k}_{w_y}) + \frac{A_{w_s}/b_s}{H} \left(\bar{k}_{w_s} \sin^4 \theta + \right. \right. \\ \left. \left. \beta_s \alpha_s \cos^4 \theta + \beta'_s \alpha'_s \frac{2}{1+\mu} \sin^2 \theta \cos^2 \theta \right) \right] \quad (48)$$

$$\bar{k}_s = \frac{1}{A_s} \left[\frac{A_{w_s}/b_s}{H} \left(\bar{k}_{w_s} \sin^2 \theta \cos^2 \theta + \beta_s \alpha_s \sin^2 \theta \cos^2 \theta - \right. \right. \\ \left. \left. \beta'_s \alpha'_s \frac{2}{1+\mu} \sin^2 \theta \cos^2 \theta \right) \right] \quad (49)$$

$$\bar{k}_{xy} = \frac{1}{A_{xy}} \left\{ \beta'_x \frac{1}{2(1+\mu)} \frac{A_{w_x}/b_y}{H} (\alpha'_x) + \beta'_y \frac{1}{2(1+\mu)} \frac{A_{w_y}/b_x}{H} (\alpha'_y) + \right. \\ \left. \frac{A_{w_s}/b_s}{H} \left[\bar{k}_{w_s} \sin^2 \theta \cos^2 \theta + \beta_s \alpha_s \sin^2 \theta \cos^2 \theta + \right. \right. \\ \left. \left. \beta'_s \alpha'_s \frac{1}{2(1+\mu)} \cos^2 2\theta \right] \right\} \quad (50)$$

$$I_x = \frac{1}{12(1-\mu^2)} \left(\frac{t_s}{H} \right)^3 + \frac{I_{w_x}/b_y}{H^3} + \frac{I_{w_s}/b_s}{H^3} \cos^4 \theta + \frac{1}{1-\mu^2} \frac{t_s}{H} (\bar{k}_x)^2 + \frac{A_{w_x}/b_y}{H} (\bar{k}_{w_x} - \bar{k}_x)^2 + \beta_y \frac{A_{w_y}/b_x}{H} (\alpha_y - \bar{k}_x)^2 + \frac{A_{w_s}/b_s}{H} \left[(\bar{k}_{w_s} - \bar{k}_x)^2 \cos^4 \theta + \beta_s (\alpha_s - \bar{k}_x)^2 \sin^4 \theta + \beta'_s (\alpha'_s - \bar{k}_x)^2 \left(\frac{2}{1+\mu} \sin^2 \theta \cos^2 \theta \right) \right] \quad (51)$$

$$I_y = \frac{1}{12(1-\mu^2)} \left(\frac{t_s}{H} \right)^3 + \frac{I_{w_y}/b_x}{H^3} + \frac{I_{w_s}/b_s}{H^3} \sin^4 \theta + \frac{1}{1-\mu^2} \frac{t_s}{H} (\bar{k}_y)^2 + \beta_x \frac{A_{w_x}/b_y}{H} (\alpha_x - \bar{k}_y)^2 + \frac{A_{w_y}/b_x}{H} (\bar{k}_{w_y} - \bar{k}_y)^2 + \frac{A_{w_s}/b_s}{H} \left[(\bar{k}_{w_s} - \bar{k}_y)^2 \sin^4 \theta + \beta_s (\alpha_s - \bar{k}_y)^2 \cos^4 \theta + \beta'_s (\alpha'_s - \bar{k}_y)^2 \left(\frac{2}{1+\mu} \sin^2 \theta \cos^2 \theta \right) \right] \quad (52)$$

$$I_s = \frac{\mu}{12(1-\mu^2)} \left(\frac{t_s}{H} \right)^3 + \frac{I_{w_s}/b_s}{H^3} \sin^2 \theta \cos^2 \theta + \frac{\mu}{1-\mu^2} \frac{t_s}{H} (\bar{k})^2 + \frac{A_{w_s}/b_s}{H} \left[(\bar{k}_{w_s} - \bar{k}_s)^2 \sin^2 \theta \cos^2 \theta + \beta_s (\alpha_s - \bar{k}_s)^2 \sin^2 \theta \cos^2 \theta - \beta'_s (\alpha'_s - \bar{k}_s)^2 \left(\frac{2}{1+\mu} \sin^2 \theta \cos^2 \theta \right) \right] \quad (53)$$

$$I_{xy} = \frac{1}{6(1+\mu)} \left(\frac{t_s}{H} \right)^3 + 4 \frac{I_{w_s}/b_s}{H^3} \sin^2 \theta \cos^2 \theta + \frac{2}{1+\mu} \frac{t_s}{H} (\bar{k}_{xy})^2 + \beta'_x \frac{2}{1+\mu} \frac{A_{w_x}/b_y}{H} (\alpha'_x - \bar{k}_{xy})^2 + \beta'_y \frac{2}{1+\mu} \frac{A_{w_y}/b_x}{H} (\alpha'_y - \bar{k}_{xy})^2 + 4 \frac{A_{w_s}/b_s}{H} \left\{ (\bar{k}_{w_s} - \bar{k}_{xy})^2 \sin^2 \theta \cos^2 \theta + \beta_s (\alpha_s - \bar{k}_{xy})^2 \sin^2 \theta \cos^2 \theta + \beta'_s (\alpha'_s - \bar{k}_{xy})^2 \left[\frac{1}{2(1+\mu)} \cos^2 2\theta \right] \right\} \quad (54)$$

where

b_x, b_y, b_s the spacing of the x -wise, y -wise, and skew ribs, respectively, in.

θ the angle of skew of the ribbing, deg

H the overall height of skin plus ribs, in.

t_s the thickness of the skin, in.

μ Poisson's ratio for material

Equations (43) to (54) contain the quantities $A_{w_x}, A_{w_y},$ and $A_{w_s}, \bar{k}_{w_x}, \bar{k}_{w_y}, \bar{k}_{w_s},$ and $I_{w_x}, I_{w_y},$ and I_{w_s} which define the areas, locations of centroids, and moments of inertia of the ribs. For rectangular ribs with circular fillets, as shown in figure 4, these quantities are given by the equations

$$\frac{A_{w_x}/b_y}{H} = \left\{ 1 - \left[1 - 0.429 \left(\frac{r_{w_x}}{t_s} \right)^2 \left(\frac{t_s}{t_{w_x}} \right) \right] \frac{t_s}{H} \right\} \frac{t_{w_x} t_s}{t_s b_y} \quad (55)$$

$$\frac{A_{w_y}/b_x}{H} = \left\{ 1 - \left[1 - 0.429 \left(\frac{r_{w_y}}{t_s} \right)^2 \left(\frac{t_s}{t_{w_y}} \right) \right] \frac{t_s}{H} \right\} \frac{t_{w_y} t_s}{t_s b_x} \quad (56)$$

$$\frac{A_{w_s}/b_s}{H} = 2 \left\{ 1 - \left[1 - 0.429 \left(\frac{r_{w_s}}{t_s} \right)^2 \left(\frac{t_s}{t_{w_s}} \right) \right] \frac{t_s}{H} \right\} \frac{t_{w_s} t_s}{t_s b_s} \quad (57)$$

(Eq. (57) contains a factor 2 to account for the fact that there are two ribs in the skewed direction—one at an angle $+\theta$ to the x -direction and the other at an angle $-\theta$ to the x -direction.)

$$\bar{k}_{w_x} = \frac{1}{A_{w_x}/b_y} \left[\frac{1}{2} \left(1 - \frac{t_s}{H} \right)^2 + 0.096 \left(\frac{r_{w_x}}{t_s} \right)^3 \left(\frac{t_s}{t_{w_x}} \right) \left(\frac{t_s}{H} \right)^2 \right] \frac{t_{w_x} t_s}{t_s b_y} + \frac{1}{2} \frac{t_s}{H} \quad (58)$$

$$\bar{k}_{w_y} = \frac{1}{A_{w_y}/b_x} \left[\frac{1}{2} \left(1 - \frac{t_s}{H} \right)^2 + 0.096 \left(\frac{r_{w_y}}{t_s} \right)^3 \left(\frac{t_s}{t_{w_y}} \right) \left(\frac{t_s}{H} \right)^2 \right] \frac{t_{w_y} t_s}{t_s b_x} + \frac{1}{2} \frac{t_s}{H} \quad (59)$$

$$\bar{k}_{w_s} = \frac{2}{A_{w_s}/b_s} \left[\frac{1}{2} \left(1 - \frac{t_s}{H} \right)^2 + 0.096 \left(\frac{r_{w_s}}{t_s} \right)^3 \left(\frac{t_s}{t_{w_s}} \right) \left(\frac{t_s}{H} \right)^2 \right] \frac{t_{w_s} t_s}{t_s b_s} + \frac{1}{2} \frac{t_s}{H} \quad (60)$$

$$\frac{I_{w_x}/b_y}{H^3} = \left\{ \frac{1}{12} \left(1 - \frac{t_s}{H} \right)^3 + \left(1 - \frac{t_s}{H} \right) \left(\frac{1}{2} - \bar{k}_{w_x} \right)^2 + 0.00755 \left(\frac{r_{w_x}}{t_s} \right)^4 \left(\frac{t_s}{t_{w_x}} \right) \left(\frac{t_s}{H} \right)^3 + 0.429 \left(\frac{r_{w_x}}{t_s} \right)^2 \left(\frac{t_s}{t_{w_x}} \right) \left(\frac{t_s}{H} \right) \left[\bar{k}_{w_x} - \frac{1}{2} \frac{t_s}{H} - 0.223 \left(\frac{r_{w_x}}{t_s} \right) \left(\frac{t_s}{H} \right)^2 \right] \right\} \frac{t_{w_x} t_s}{t_s b_y} \quad (61)$$

$$\frac{I_{w_y}/b_x}{H^3} = \left\{ \frac{1}{12} \left(1 - \frac{t_s}{H} \right)^3 + \left(1 - \frac{t_s}{H} \right) \left(\frac{1}{2} - \bar{k}_{w_y} \right)^2 + 0.00755 \left(\frac{r_{w_y}}{t_s} \right)^4 \left(\frac{t_s}{t_{w_y}} \right) \left(\frac{t_s}{H} \right)^3 + 0.429 \left(\frac{r_{w_y}}{t_s} \right)^2 \left(\frac{t_s}{t_{w_y}} \right) \left(\frac{t_s}{H} \right) \left[\bar{k}_{w_y} - \frac{1}{2} \frac{t_s}{H} - 0.223 \left(\frac{r_{w_y}}{t_s} \right) \left(\frac{t_s}{H} \right)^2 \right] \right\} \frac{t_{w_y} t_s}{t_s b_x} \quad (62)$$

$$\frac{I_{w_s}/b_s}{H^3} = 2 \left\{ \frac{1}{12} \left(1 - \frac{t_s}{H} \right)^3 + \left(1 - \frac{t_s}{H} \right) \left(\frac{1}{2} - \bar{k}_{w_s} \right)^2 + 0.00755 \left(\frac{r_{w_s}}{t_s} \right)^4 \left(\frac{t_s}{t_{w_s}} \right) \left(\frac{t_s}{H} \right)^3 + 0.429 \left(\frac{r_{w_s}}{t_s} \right)^2 \left(\frac{t_s}{t_{w_s}} \right) \left(\frac{t_s}{H} \right) \left[\bar{k}_{w_s} - \frac{1}{2} \frac{t_s}{H} - 0.223 \left(\frac{r_{w_s}}{t_s} \right) \left(\frac{t_s}{H} \right)^2 \right] \right\} \frac{t_{w_s} t_s}{t_s b_s} \quad (63)$$

The values of $k_I, k_{II},$ and k_{III} depend upon the locations of the centroids of the forces $N_x, N_y,$ and $N_{xy},$ respectively, imposed upon the plate element. (See fig. 2.) For the important case in which N_x acts in such a plane that it produces

no curvature $\frac{\partial^2 w}{\partial x^2}$ and N_y acts in such a plane that it produces

no curvature $\frac{\partial^2 w}{\partial y^2}, C_{xx}$ and C_{yy} must equal zero (see eqs. 1 and 2) and, therefore,

$$k_I = \frac{A_x A_y \bar{k}_x - A_s^2 \bar{k}_s + \mu_x A_s A_y (\bar{k}_y - \bar{k}_s)}{A_s^2} \quad (64)$$

$$k_{II} = \frac{A_x A_y \bar{k}_y - A_s^2 \bar{k}_s + \mu_y A_s A_x (\bar{k}_x - \bar{k}_s)}{A_s^2} \quad (65)$$

Similarly, for the case in which N_{xy} acts in such a plane that it produces no twist $\frac{\partial^2 w}{\partial x \partial y}$, T must equal zero and, therefore,

$$k_{III} = \bar{k}_{xy} \quad (66)$$

If N_x and N_y do act in such planes that they produce curvatures $\frac{\partial^2 w}{\partial x^2}$ and $\frac{\partial^2 w}{\partial y^2}$, the actual locations of the forces (planes I and II) must be known if constants (such as E_x , μ'_x , etc.) which depend upon the locations of the applied forces are to be evaluated.

The average or equivalent thickness of integrally stiffened plates having rectangular ribs with circular fillets in the various configurations considered herein may be calculated from the following formulas: For simple longitudinal or transverse ribbing (fig. 1(a)),

$$\frac{\bar{t}}{H} = 1 - \frac{\left(\frac{H}{t_s} - 1\right) \left(\frac{b_x - t_{w_x}}{t_s} - 0.429 \left(\frac{r_{w_x}}{t_s}\right)^2\right)}{\frac{H}{t_s} \frac{b_x}{t_s}} \quad (67)$$

or

$$\frac{\bar{t}}{H} = 1 - \frac{\left(\frac{H}{t_s} - 1\right) \left(\frac{b_y - t_{w_y}}{t_s} - 0.429 \left(\frac{r_{w_y}}{t_s}\right)^2\right)}{\frac{H}{t_s} \frac{b_y}{t_s}} \quad (68)$$

For combined longitudinal and transverse ribbing (fig. 1(b)) having a corner radius $R_w \geq r_w$ and with r_{w_x} blending smoothly with r_{w_y} at the corners,

$$\frac{\bar{t}}{H} = 1 - \frac{\left[\left(\frac{H}{t_s} - 1\right) \left[\left(\frac{b_x - t_{w_x}}{t_s} - 0.858 \left(\frac{R_w}{t_s}\right)^2\right) - 0.429 \left\{ \left(\frac{r_{w_x}}{t_s}\right)^2 \left(\frac{b_y - t_{w_y}}{t_s}\right) + \left(\frac{r_{w_y}}{t_s}\right)^2 \left(\frac{b_x - t_{w_x}}{t_s}\right) - 2 \left[\left(\frac{r_{w_x}}{t_s}\right)^2 + \left(\frac{r_{w_y}}{t_s}\right)^2 - \frac{\pi (r_{w_x} r_{w_y})}{2 t_s} \right] \right\} \right] R_w - (0.351) \frac{r_{w_x} r_{w_y}}{t_s} \left(\frac{r_{w_x} + r_{w_y}}{t_s}\right) \right]}{\frac{H}{t_s} \frac{b_x}{t_s} \frac{b_y}{t_s}} \quad (69)$$

For the special square pattern of longitudinal and transverse ribbing having $t_{w_x} = t_{w_y}$ and $r_{w_x} = r_{w_y}$, equation (69) reduces to

$$\frac{\bar{t}}{H} = 1 - \frac{\left(\frac{H}{t_s} - 1\right) \left[\left(\frac{b_x - t_{w_x}}{t_s}\right)^2 - 0.858 \left(\frac{R_w}{t_s}\right)^2 \right] - 0.429 \left(\frac{r_{w_x}}{t_s}\right)^2 \left\{ 2 \left[\left(\frac{b_x - t_{w_x}}{t_s}\right) - 0.429 \frac{R_w}{t_s} - 0.351 \frac{r_{w_x}}{t_s} \right] \right\}}{\frac{H}{t_s} \left(\frac{b_x}{t_s}\right)^2} \quad (69a)$$

For skewed ribbing (fig. 1(c)), again for $R_w \geq r_w$,

$$\frac{\bar{t}}{H} = 1 - \frac{\left(\frac{H}{t_s} - 1\right) \left[\left(\frac{b_s - t_{w_s}}{t_s}\right)^2 \csc 2\theta + (\pi - 4 \csc 2\theta) \left(\frac{R_w}{t_s}\right)^2 \right] - 0.429 \left(\frac{r_{w_s}}{t_s}\right)^2 \left\{ 2 \left[\left(\frac{b_s - t_{w_s}}{t_s} - 2 \frac{R_w}{t_s}\right) \csc 2\theta + \frac{\pi R_w}{2 t_s} - 0.351 \frac{r_{w_s}}{t_s} \right] \right\}}{\frac{H}{t_s} \left(\frac{b_s}{t_s}\right)^2 \csc 2\theta} \quad (70)$$

For 45° skewed ribbing, equation (70) reduces to the form equivalent to (69a); thus,

$$\frac{\bar{t}}{H} = 1 - \frac{\left(\frac{H}{t_s} - 1\right) \left[\left(\frac{b_s - t_{w_s}}{t_s}\right)^2 - 0.858 \left(\frac{R_w}{t_s}\right)^2 \right] - 0.429 \left(\frac{r_{w_s}}{t_s}\right)^2 \left\{ 2 \left[\left(\frac{b_s - t_{w_s}}{t_s}\right) - 0.429 \frac{R_w}{t_s} - 0.351 \frac{r_{w_s}}{t_s} \right] \right\}}{\frac{H}{t_s} \left(\frac{b_s}{t_s}\right)^2} \quad (70a)$$

For combined skewed ribbing and transverse (or longitudinal) ribbing in a pattern of triangles, again for $R_w \geq r_w$,

$$\frac{\bar{t}}{H} = 1 - \frac{\left[\left(\frac{H}{t_s} - 1\right) \left\{ \left(\frac{b_s - t_{w_s} - t_{w_y}}{t_s}\right)^2 \csc 2\theta + 2 [\pi - (1 + \csc \theta)^2 \tan \theta] \left(\frac{R_w}{t_s}\right)^2 \right\} - 0.429 \left[2 \left(\frac{r_{w_s}}{t_s}\right)^2 \left(\frac{b_s - t_{w_s} - t_{w_y}}{t_s} \sin \theta\right) \csc 2\theta + \left(\frac{r_{w_y}}{t_s}\right)^2 \left(\frac{b_s - t_{w_s} - t_{w_y}}{t_s} \sin \theta\right) \sec \theta \right] \right]}{\frac{H}{t_s} \left(\frac{b_s}{t_s}\right)^2 \csc 2\theta} + \frac{0.858 \left\{ \left(\frac{r_{w_s}}{t_s}\right)^2 \left[\cot \theta + \cot \left(\frac{90 - \theta}{2}\right) \right] + \left(\frac{r_{w_y}}{t_s}\right)^2 \cot \left(\frac{90 - \theta}{2}\right) - \pi \frac{r_{w_s} r_{w_y}}{t_s} \right\} R_w + 1.404 (0.429) \frac{r_{w_s} r_{w_y}}{t_s} \left[\left(\frac{270 - \theta}{360}\right) \frac{r_{w_s}}{t_s} + \left(\frac{90 + \theta}{360}\right) \frac{r_{w_y}}{t_s} \right]}{\frac{H}{t_s} \left(\frac{b_s}{t_s}\right)^2 \csc 2\theta} \quad (71)$$

For the special equilateral triangle pattern having $t_{w_x} = t_{w_y} = t_w$ and $r_{w_x} = r_{w_y} = r_w$, as considered in reference 7, equation (71) reduces to

$$\frac{\bar{t}}{H} = 1 - \frac{\left(\frac{H}{t_s} - 1\right) \left[\left(\frac{b_x}{t_s} - 1.5 \frac{t_w}{t_s}\right)^2 - 3.56 \left(\frac{R_w}{t_s}\right)^2 \right] - 0.429 \left(\frac{r_w}{t_s}\right)^2 \left\{ 3 \left[\left(\frac{b_x}{t_s} - 1.5 \frac{t_w}{t_s}\right) - 1.186 \frac{R_w}{t_s} - 0.406 \frac{r_w}{t_s} \right] \right\}}{\frac{H}{t_s} \left(\frac{b_x}{t_s}\right)^2} \quad (71a)$$

For combined longitudinal and transverse and skewed ribbing as illustrated in figure 3(a), for $R_w \geq r_w$ as before,

$$\begin{aligned} \frac{\bar{t}}{H} = 1 - & \frac{\left[\left(\frac{H_x}{t_s} - 1\right) \left\{ \frac{1}{2} \left[\left(\frac{b_x}{t_s} - \frac{t_{w_x}}{t_s} \sec \theta - \frac{t_{w_y}}{t_s} \csc \theta - \frac{t_{w_z}}{t_s} \cot \theta\right) \right. \right. \right. \\ & \left. \left. \left(\frac{b_y}{t_s} - \frac{t_{w_x}}{t_s} \csc \theta - \frac{t_{w_y}}{t_s} \sec \theta - \frac{t_{w_z}}{t_s} \tan \theta\right) \right] + 2 \left\{ 2\pi - [(1 + \sec \theta)^2 + (1 + \csc \theta)^2] \right\} \left(\frac{R_w}{t_s}\right)^2 \right\}}{\frac{H}{t_s} \frac{b_x}{t_s} \frac{b_y}{t_s}} + \\ & \frac{\left[-0.429 \left\{ \left(\frac{r_{w_x}}{t_s}\right)^2 \left(\frac{b_y}{t_s} - \frac{t_{w_x}}{t_s} \csc \theta - \frac{t_{w_y}}{t_s} \cot \theta\right) + \left(\frac{r_{w_y}}{t_s}\right)^2 \left(\frac{b_x}{t_s} - \frac{t_{w_x}}{t_s} \sec \theta - \frac{t_{w_y}}{t_s} \tan \theta\right) \right. \right. \\ & \left. \left. + 2 \left(\frac{r_{w_z}}{t_s}\right)^2 \left(\frac{b_y}{t_s} \sec \theta - \frac{1}{2} \frac{t_{w_x}}{t_s} \left[\cot \theta + \cot \{90 - \theta\} + \cot \frac{\theta}{2} + \cot \left\{ \frac{90 - \theta}{2} \right\} \right] \right) \right\}}{\frac{H}{t_s} \frac{b_x}{t_s} \frac{b_y}{t_s}} + \\ & \left. \frac{\left[0.858 \left\{ \left(\frac{r_{w_x}}{t_s}\right)^2 \cot \frac{\theta}{2} + \left(\frac{r_{w_y}}{t_s}\right)^2 \cot \left(\frac{90 - \theta}{2}\right) + \left(\frac{r_{w_z}}{t_s}\right)^2 \left(\cot \theta + \cot \{90 - \theta\} + \cot \frac{\theta}{2} + \cot \left\{ \frac{90 - \theta}{2} \right\} \right) \right. \right. \\ & \left. \left. + \pi \left(\frac{r_{w_x}}{t_s}\right) \left(\frac{r_{w_x}}{t_s} + \frac{r_{w_y}}{t_s}\right) \right\} \frac{R_w}{t_s} + 0.301 \left\{ \left(\frac{r_{w_x}}{t_s}\right)^2 + \left(\frac{r_{w_y}}{t_s}\right)^2 + \frac{r_{w_x}}{t_s} \left(\frac{r_{w_x}}{t_s} + \frac{r_{w_y}}{t_s}\right) \right\} \frac{r_{w_x}}{t_s} \right]}{\frac{H}{t_s} \frac{b_x}{t_s} \frac{b_y}{t_s}} \quad (72) \end{aligned}$$

and, finally, for the special case of combined longitudinal and transverse and skewed ribbing illustrated in figure 1(d) having $t_{w_x} = t_{w_y} = t_w$, $r_{w_x} = r_{w_y} = r_w$, and $b_x = b_y = 1.414 b_s$, equation (72) reduces to

$$\frac{\bar{t}}{H} = 1 - \frac{\left(\frac{H}{t_s} - 1\right) \left[\left(\frac{b_x}{t_s} - 2.414 \frac{t_w}{t_s}\right)^2 - 10.82 \left(\frac{R_w}{t_s}\right)^2 \right] - 0.429 \left(\frac{r_w}{t_s}\right)^2 \left[4.828 \left(\frac{b_x}{t_s} - 2.414 \frac{t_w}{t_s}\right) - 10.75 \frac{R_w}{t_s} - 1.404 \frac{r_w}{t_s} \right]}{\frac{H}{t_s} \left(\frac{b_x}{t_s}\right)^2} \quad (72a)$$

EVALUATION OF α AND β [†]

EXPERIMENTAL EVALUATION

The coefficients α , β , α' , and β' occurring in the equations for the elastic constants express the effectiveness of a rib for resisting deformations other than bending and stretching in its longitudinal direction. For the evaluation of α and β for a given set of ribs (longitudinal, transverse, or skewed) probably sufficient accuracy will be achieved from a direct experimental measurement with a simple model having one set of ribs with cross section and spacing that duplicate those of the ribs for which the coefficients α and β are being sought and with a value of t_s equal to that of the actual plate.

A double specimen of the type shown on the right-hand side of figure 5 may first be used to evaluate β through a tension test and, then, one-half of the specimen may be used to evaluate α through a bending test, as illustrated on the left-hand side of figure 5. The use of a double specimen for the stretching test is suggested because the symmetry will eliminate localized bending of the skin between ribs and facil-

itate the measurement of overall strain. Because of the prevention of localized bending, the value of β should be somewhat higher than that which would be obtained by stretching a single specimen like the one on the left-hand side of figure 5. However, such an overestimate of β may be desirable if the actual plate has ribs in more than one direction, because then the localized curvatures associated with one set of ribs will tend to be reduced by the presence of the other ribs.

The length-width ratio of the specimen should be great enough so that any end grips or heavy end sections will offer negligible resistance to transverse contraction in the stretching test and to the development of transverse curvature in the bending test. Furthermore, the width of the specimen should be sufficiently large compared with the rib spacing so that the percentage of the specimen subject to shear-lag effects arising at the rib ends is small.

The use of these tests for the evaluation of α and β are now described in detail. For ease in discussion, the ribs for which α and β are being sought are assumed to be oriented in the y -direction as shown in figure 5. After the values of α_y and β_y have been determined, however, the subscript y should be changed to x or s if, in the actual plate, the ribs under

[†]Subsequent work has shown that the approximation $\beta \approx \frac{1}{6}\beta'$ is adequate for all practical purposes (see ref. 8).

consideration are oriented in the longitudinal or skew direction of the plate.

The conditions of the stretching test illustrated in the

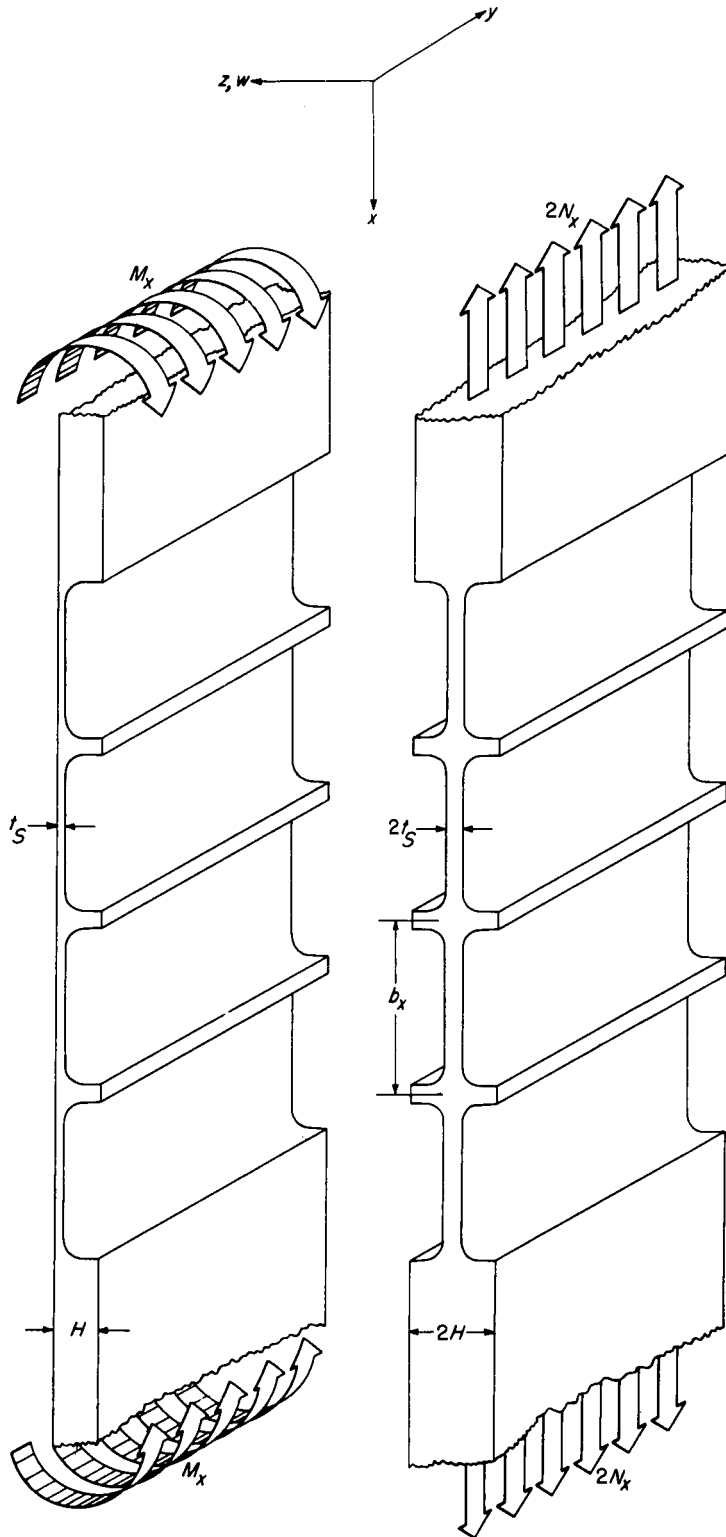

FIGURE 5.—Specimens for evaluation of α and β .

right-hand side of figure 5 are $\frac{\partial^2 w}{\partial x^2} = \frac{\partial^2 w}{\partial y^2} = N_y = 0$. Substituting these conditions in equation (10) and making use of equations (31), (41), (43), (44), and (45) gives

$$\begin{aligned} \frac{N_x}{\epsilon_x} &= E_1 \\ &= EH \frac{\bar{A}_s^2}{A_y} \\ &= EH \frac{A_x A_y - A_s^2}{A_y} \\ &= EH \frac{\left(\frac{1}{1-\mu^2} \frac{t_s}{H} + \beta_v \frac{A_{wy}/b_x}{H} \right) \left(\frac{1}{1-\mu^2} \frac{t_s}{H} + \frac{A_{wy}/b_x}{H} \right) - \left(\frac{\mu}{1-\mu^2} \frac{t_s}{H} \right)^2}{\frac{1}{1-\mu^2} \frac{t_s}{H} + \frac{A_{wy}/b_x}{H}} \end{aligned} \quad (73)$$

Solving for β_v gives

$$\beta_v = \frac{1}{\frac{A_{wy}/b_x}{H}} \left\{ \frac{N_x}{EH\epsilon_x} - \frac{t_s}{H} \left[\frac{\frac{t_s}{H} + \frac{A_{wy}/b_x}{H}}{\frac{t_s}{H} + \frac{A_{wy}/b_x}{H} (1-\mu^2)} \right] \right\} \quad (74)$$

where, for rectangular ribs with circular fillets, $\frac{A_{wy}/b_x}{H}$ is as given by equation (56). If the value obtained in the stretching test is used for $N_x/EH\epsilon_x$ in the right-hand side of equation (74), an experimental value of β_v , or β_{vexp} , is obtained (ϵ_x is the x -wise strain averaged over at least one multiple of b_x).

The conditions of the bending test illustrated in the left-hand side of figure 5 are $N_x = N_y = M_y = 0$. Substituting these conditions in equation (1) and making use of equations (13), (19), (42), (47), (49), (51), and (53) gives

$$\frac{\partial^2 w}{\partial x^2} = -\frac{M_x}{D_x} = -\frac{M_x}{EH^3} \frac{1}{I_x - \frac{A_s^2 A_x}{A_s^2} (\bar{k}_x - \bar{k}_s)^2 - \mu_x \left(\frac{\bar{I}_s^2}{A_s^2} \right)} \quad (75)$$

where

$$\left. \begin{aligned} I_x &= \frac{1}{12(1-\mu^2)} \left(\frac{t_s}{H} \right)^3 + \frac{1}{1-\mu^2} \frac{t_s}{H} (\bar{k}_x)^2 + \beta_v \frac{A_{wy}/b_x}{H} (\alpha_v - \bar{k}_x)^2 \\ \bar{k}_x &= \frac{\alpha_v}{A_x} \beta_v \frac{A_{wy}/b_x}{H} \\ \bar{k}_s &= 0 \\ \mu_x &= \frac{\bar{I}_s^2}{I_y \bar{A}_s^2 - A_s^2 A_y \bar{k}_y^2} \\ \bar{I}_s^2 &= I_s \bar{A}_s^2 + A_s A_x A_y \bar{k}_x \bar{k}_y \end{aligned} \right\} \quad (76)$$

Solving for α_v gives

$$\alpha_v = \frac{I_s A_v \bar{k}_v + \sqrt{\left[\begin{aligned} & I_s^2 A_v^2 \bar{k}_v^2 - \left\{ \left[\frac{1}{\mu} \frac{A_s}{A_s^2} \left(\beta_v \frac{A_{w_v}/b_z}{H} \right) \right] \left[\frac{I_v \bar{A}_s^2 - A_s^2 A_v \bar{k}_v^2}{A_s A_s \left(\beta_v \frac{A_{w_v}/b_z}{H} \right)} - \frac{A_v^2 \bar{k}_v^2}{A_s^2} \right] \right\} \times \\ & \left\{ \left[\frac{1}{\mu} (I_v \bar{A}_s^2 - A_s^2 A_v \bar{k}_v^2) - I_s \bar{A}_s^2 \right] I_s + \frac{M_x}{EH^3} \frac{\partial^2 w}{\partial x^2} (I_v \bar{A}_s^2 - A_s^2 A_v \bar{k}_v^2) \right\} \end{aligned} \right]}{\frac{1}{A_s} \left[\frac{1}{\mu} \frac{A_s}{A_s^2} \left(\beta_v \frac{A_{w_v}/b_z}{H} \right) \right] (I_v \bar{A}_s^2 - A_s^2 A_v \bar{k}_v^2) - \frac{A_s A_v^2 \bar{k}_v^2}{A_s^2} \left(\beta_v \frac{A_{w_v}/b_z}{H} \right)} \quad (77)$$

where, as before, for rectangular ribs with circular fillets, $\frac{A_{w_v}/b_z}{H}$ is as given by equation (56).

Substituting for $M_x/EH^3 \frac{\partial^2 w}{\partial x^2}$ the value obtained in the bending test, and for β_v the value obtained from equation (74) permits equation (77) to yield an experimental value of α_v ($\frac{\partial^2 w}{\partial x^2}$ is the x -wise curvature averaged over at least one multiple of b_x). The quantities \bar{A}_s^2 , A_s , A_v , A_s , \bar{k}_v , I_v , I_s are obtained from equations (41), (43), (44), (45), (48), (52), and (53), respectively, with $A_{w_x} = A_{w_s} = I_{w_x} = I_{w_s} = 0$; thus,

$$\left. \begin{aligned} \bar{A}_s^2 &= A_s A_v - A_s^2 \\ A_s &= \frac{A_s}{\mu} + \beta_v \frac{A_{w_v}/b_z}{H} & A_v &= \frac{A_s}{\mu} + \frac{A_{w_v}/b_z}{H} & A_s &= \frac{\mu}{1-\mu^2} \frac{t_s}{H} \\ \bar{k}_v &= \frac{1}{A_v} \frac{A_{w_v}/b_z}{H} \bar{k}_{w_v} \\ I_v &= \frac{I_s}{\mu} + \frac{\bar{k}_{w_v} \bar{k}_v A_s}{\mu} + \frac{I_{w_v}/b_z}{H^3} & I_s &= \frac{\mu}{12(1-\mu^2)} \left(\frac{t_s}{H} \right)^3 \end{aligned} \right\} \quad (78)$$

where \bar{k}_{w_v} is as given by equation (59).

THEORETICAL EVALUATION

Accurate theoretical analysis of the situations depicted in figure 5 is difficult. However, it is possible to obtain values of α and β that underestimate or overestimate the stiffness of the specimens. An underestimate is obviously obtained by assuming no part of the rib to be effective in resisting transverse stretching or bending in a direction transverse to itself. A lower limit-value of β is, therefore,

$$\beta = \beta_{LL} = 0 \quad (79)$$

When β is taken as zero, the value of α is immaterial.

An overestimate is obtained by analyzing the two speci-

mens shown in figure 5 for their small deformations under the assumption that plane sections perpendicular to the skin and perpendicular or parallel to the direction of ribbing remain plane. The results of such an analysis of the two situations illustrated in figure 5 are as follows:

For the double specimen on the right-hand side of figure 5,

$$\frac{N_x}{EH \epsilon_x} = \frac{t_s/H}{(1-\mu^2)g \frac{t_s}{b_x} + \frac{\mu^2}{1 + \frac{A_{w_v}/b_z}{H} \left(\frac{H}{t_s} \right)}} \quad (80)$$

For the single specimen on the left-hand side of figure 5,

$$\frac{M_x}{EH^3 \frac{\partial^2 w}{\partial x^2}} = \frac{1}{12(1-\mu^2)f \left(\frac{t_s}{b_x} \right) \left(\frac{H}{t_s} \right)^3 + \frac{\mu^2}{I/b_x H^3}} \quad (81)$$

where I , g , and f are geometric properties of segments of length b_x of the cross sections shown. The symbol I represents the moment of inertia of such a segment about its centroid, g is the integral, taken in the x -direction, of the reciprocal of the local thickness measured in the z -direction, and f is t_s^2 times a similar integral of the cube of the reciprocal of the local thickness. When the ribs are rectangular with circular fillets, these quantities are given by the following formulas:

$$\begin{aligned} \frac{I/b_x}{H^3} &= \frac{1}{12} \left(\frac{t_s}{H} \right)^3 + \frac{t_s}{H} \left[\frac{\frac{1}{2} \frac{t_s}{H} + \frac{H}{t_s} \left(\frac{A_{w_v}/b_z}{H} \right) \left(\frac{1}{2} \frac{t_s}{H} + \bar{k}_{w_v} \right)^2}{\frac{H}{t_s} \left(\frac{A_{w_v}/b_z}{H} \right) + 1} \right]^2 \\ \frac{I_{w_v}/b_x}{H^3} + \frac{A_{w_v}/b_x}{H} &= \left[\frac{1}{2} \frac{t_s}{H} + \bar{k}_{w_v} - \frac{\frac{1}{2} \frac{t_s}{H} + \frac{H}{t_s} \left(\frac{A_{w_v}/b_z}{H} \right) \left(\frac{1}{2} \frac{t_s}{H} + \bar{k}_{w_v} \right)}{\frac{H}{t_s} \left(\frac{A_{w_v}/b_z}{H} \right) + 1} \right]^2 \end{aligned} \quad (82)$$

$$g = \frac{b_x}{t_s} - \frac{t_{w_y}}{t_s} - 2 \frac{r_{w_y}}{t_s} + \frac{t_{w_y}}{t_s} \frac{t_s}{H} + g' \quad (83)$$

$$f = \frac{b_x}{t_s} - \frac{t_{w_y}}{t_s} - 2 \frac{r_{w_y}}{t_s} + \frac{t_{w_y}}{t_s} \left(\frac{t_s}{H}\right)^3 + f' \quad (84)$$

where g' and f' are functions of the ratio of fillet radius to skin thickness given by the equations

$$g' = 4 \left\{ \sqrt{\frac{1}{1+2\frac{r_w}{t_s}}} + \sqrt{\frac{1}{\frac{t_s}{r_w} \left(\frac{t_s}{r_w} + 2\right)}} \right\} \left\{ \tan^{-1} \sqrt{1+2\frac{r_w}{t_s}} \right\} - \pi \quad (85)$$

$$f' = \frac{1}{\frac{t_s}{r_w} + 4} \left\{ 2 + \frac{r_w}{t_s} \left[2 + \frac{1}{\frac{t_s}{r_w} + 1} + \frac{6 \left(1 + \frac{r_w}{t_s}\right)}{\sqrt{1+2\frac{r_w}{t_s}}} \tan^{-1} \sqrt{1+2\frac{r_w}{t_s}} \right] \right\} \quad (86)$$

and $\frac{I_{w_y}/b_x}{H^3}$ is as given by equation (62).

The values of $N_x/EH\epsilon_x$ and $M_x/EH^3 \frac{\partial^2 w}{\partial x^2}$ obtained from equations (80) and (81) may be thought of as experimental results and they may therefore be substituted in equations (74) and (77) to obtain values of β_{VL} and α_{VL} corresponding to an overestimate of the stiffness of the specimen.

A lower overestimate of stiffness can be obtained by analyzing, on the basis that plane sections remain plane, the single specimen on the left-hand side of figure 5 for both $N_x/EH\epsilon_x$ and $M_x/EH^3 \frac{\partial^2 w}{\partial x^2}$ and thus including the localized bending that occurs during stretching. Besides being more conservative, the resulting values of α_{VL} and β_{VL} would also be more appropriate if, in the actual plate under consideration, there were really only one set of ribs. An upper-limit analysis conducted entirely on the specimen on the left-hand side of figure 5 would yield the following expression to be used in place of equation (80):

$$\frac{N_x}{EH\epsilon_x} = \frac{t_s/H}{12(1-\mu^2) \left(\frac{g}{3} - \frac{1}{4} \frac{h^2}{f} \right) \frac{t_s}{b_x} + \frac{\mu^2}{1 + \frac{A_{w_y}/b_x}{H} \left(\frac{H}{t_s} \right)} \quad (87)$$

where h is t_s times the integral, taken over a length b_x in the x -direction, of the square of the reciprocal of the local thickness. For circular-filletted rectangular-section ribbing,

$$h = \frac{b_x}{t_s} - \frac{t_{w_y}}{t_s} - 2 \frac{r_{w_y}}{t_s} + \frac{t_{w_y}}{t_s} \left(\frac{t_s}{H}\right)^2 + h' \quad (88)$$

where h' is given by the equation:

$$h' = \frac{2}{\frac{t_s}{r_w} + 2} \left\{ 1 + 2 \left[\sqrt{\frac{1}{\frac{t_s}{r_w} \left(\frac{t_s}{r_w} + 2\right)}} \right] \tan^{-1} \sqrt{1+2\frac{r_w}{t_s}} \right\} \quad (89)$$

Equation (81) would still be used for $M_x/EH^3 \frac{\partial^2 w}{\partial x^2}$.

EVALUATION OF α' AND β'

The coefficients α' and β' , which define the effectiveness of a rib in resisting twisting and shearing relative to its longitudinal and transverse directions, are not as readily measured experimentally nor as readily bounded by an upper limit as α and β , although, of course, a lower-limit stiffness is obtained by equating β' to zero.

An approximate evaluation of α' and β' may be made by assuming that the same volume of rib material resists shear as resists transverse stretching, that is,

$$\beta'_v = \beta_v \quad (90)$$

and then by determining from computations where this material must be placed (as measured by α') in order to give the proper torsional stiffness as determined with the aid of reference 9. The computation of α' is now described in detail.

Consider an element, like the one on the left-hand side of figure 5, having only y -wise ribbing and subjected to a pure M_{xy} loading. From equations (3), (15), and (54) the value of α'_v can be obtained in terms of the measured or computed ratio $M_{xy}/\frac{\partial^2 w}{\partial x \partial y}$ as follows:

$$\begin{aligned} \frac{M_{xy}}{\frac{\partial^2 w}{\partial x \partial y}} &= D_{xy} \\ &= \frac{1}{2} EH^3 I_{xy} \\ &= \frac{1}{2} EH^3 \left[\frac{1}{6(1+\mu)} \left(\frac{t_s}{H}\right)^3 + \frac{2}{1+\mu} \frac{t_s}{H} (\bar{k}_{xy})^2 + \beta'_v \frac{2}{1+\mu} \frac{A_{w_y}/b_x}{H} (\alpha'_v - \bar{k}_{xy})^2 \right] \end{aligned} \quad (91)$$

where

$$\bar{k}_{xy} = \frac{\beta'_v \frac{A_{w_y}/b_x}{H} (\alpha'_v)}{\frac{t_s}{H} + \beta'_v \frac{A_{w_y}/b_x}{H}} \quad (92)$$

Solving for α'_v gives

$$\alpha'_v = \sqrt{\frac{1}{2} \left(\frac{1}{\beta'_v \frac{A_{w_y}/b_x}{H}} + \frac{H}{t_s} \right) \left[\frac{M_{xy}}{EH^3 \frac{\partial^2 w}{\partial x \partial y}} - \frac{1}{6} \left(\frac{t_s}{H}\right)^3 \right]} \quad (93)$$

[†]A comprehensive evaluation of α' and β' is now available in reference 8.

The value of the ratio $M_{xy}/\frac{EH^3}{2(1+\mu)}\frac{\partial^2 w}{\partial x \partial y}$ to be inserted in equation (93) can, in the absence of test data, be derived by an adaptation of the method used in reference 9 for computing the torsional stiffness of I-beams and H-beams, which gives

$$\frac{M_{xy}}{EH^3 \frac{\partial^2 w}{\partial x \partial y}} = \frac{1}{2} \left[\frac{1}{3} \left(\frac{t_s}{H} \right)^3 + \frac{1}{3} \left(1 - \frac{t_s}{H} \right) \left(\frac{t_{wy}}{t_s} \right)^3 \left(\frac{t_s}{H} \right)^2 \left(\frac{t_s}{b_x} \right) - 0.105 \left(\frac{t_{wy}}{t_s} \right)^4 \left(\frac{t_s}{H} \right)^3 \left(\frac{t_s}{b_x} \right) + a \left(\frac{d}{t_s} \right)^4 \left(\frac{t_s}{H} \right)^3 \left(\frac{t_s}{b_x} \right) \right] \quad (94)$$

where d is the diameter of the largest circle which can be inscribed in the cross section at the junction of the rib and skin and can be computed from the formula

$$\frac{d}{t_s} = \frac{\left(1 + \frac{r_{wy}}{t_s} \right)^2 + \frac{t_{wy}}{t_s} \left(\frac{r_{wy}}{t_s} + \frac{1}{4} \frac{t_{wy}}{t_s} \right)}{2 \left(\frac{r_{wy}}{t_s} \right) + 1} \quad (95)$$

The constant a in the last term of equation (94) depends on t_{wy}/t_s and r_{wy}/t_s . The value of a is obtainable from figure 7 of reference 9 or, when $\frac{t_{wy}}{t_s} \geq 0.61 - 0.23 \left(\frac{r_{wy}}{t_s} \right)$, from the following formula:

$$a = 0.094 + 0.070 \frac{r_{wy}}{t_s} \quad (96)$$

The meanings of the various terms within the parentheses of equation (94) are apparent: $\frac{1}{3} \left(\frac{t_s}{H} \right)^3$ represents the contribution of the skin, considered as an infinite plate, to the twisting stiffness of the waffle; $\frac{1}{3} \left(1 - \frac{t_s}{H} \right) \left(\frac{t_{wy}}{t_s} \right)^3 \left(\frac{t_s}{H} \right)^2 \left(\frac{t_s}{b_x} \right)$ is similarly representative of the twisting stiffness of the rib; the term with $-0.105 \left(\frac{t_{wy}}{t_s} \right)^4$ corrects for the fact that the rib is actually not infinitely deep; and the term with $a \left(\frac{d}{t_s} \right)^4$ represents the additional stiffness due to the fillets. The value 0.105 is based on the assumption that $\frac{2b_{wy}}{t_{wy}} \geq 2.3$; for values of $2b_{wy}/t_{wy}$ less than 2.3, the number 0.105 should be replaced by the number obtainable in figure 3 of reference 9 with the abscissa label b/n replaced by the label $2b_{wy}/t_{wy}$.

COMPARISON OF CALCULATED AND EXPERIMENTALLY MEASURED VALUES OF ELASTIC CONSTANTS

As a partial check on the theory, experimental measurements were made of the stretching stiffness E_1 , bending stiffness D_x , shearing stiffness G_x , and twisting stiffness D_{xy} of plates with integral ribs running either longitudinally or trans-

versely (fig. 1(a)) or skewed (fig. 1 (c)). The procedures used for the measurement of D_x and D_{xy} were essentially the same as those described in reference 6 for sandwich plates. The measurements of E_1 and G_x were made with long-gage-length resistance-type wire strain gages mounted in the four corners (or diagonally on the four sides) of square-tube compression or torsion specimens similar to the square tubes of reference 5. The compression specimens were tested in the 1,200,000-pound-capacity testing machine and the torsion specimens in the combined load testing machine of the Langley structures research laboratory.

The experimental values obtained for the stiffnesses are indicated by the circles in figures 6 and 7. In figure 6 the stiffnesses are plotted against the angle of skew of the ribbing (with $\theta=0^\circ$ and $\theta=90^\circ$ corresponding to purely longitudinal and purely transverse ribbing, respectively) for plates having nominally the same weight. In figure 7, for a given angle of skew ($\theta=45^\circ$), the variation of the elastic constants with skin thickness is plotted. The relatively large scatter in the test data is due to the fact that the plates used were sand castings and, hence, had appreciable variations in thicknesses from one specimen to another and also within each specimen.

For comparison, theoretical values of the four elastic constants were computed from equations (31), (13), (33), and

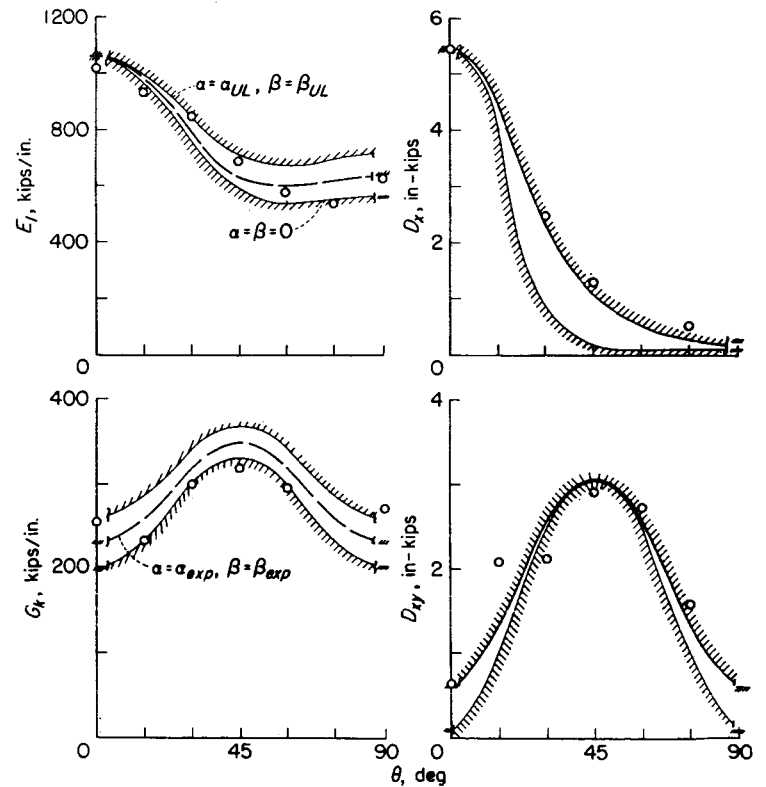

FIGURE 6.—Calculated and experimentally measured elastic constants for plates with integral, waffle-like stiffening skewed at angles of $\pm\theta$ to the longitudinal direction, having $b_w=0.2$ in., $E=10.7 \times 10^3$ ksi, $\mu=0.32$, and having the following proportions: $\frac{b_w}{t_s}=4$, $\frac{b_w}{t_w}=2$, $\frac{b_w}{r_w}=2$; in addition, for $\theta=0^\circ$ or 90° , $\frac{b_w}{b_s}=0.4$ and for $0^\circ < \theta < 90^\circ$, $\frac{b_w}{b_s}=0.2$

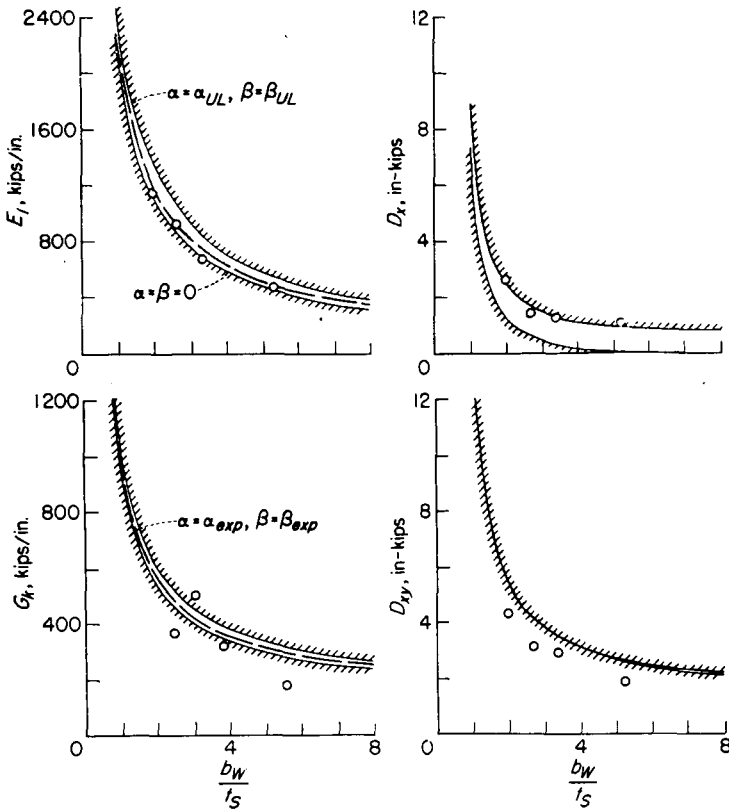

FIGURE 7.—Calculated and experimentally measured elastic constants for plates having integral, waffle-like stiffening skewed at angles of $\pm 45^\circ$ to the longitudinal direction and having $\frac{b_w}{t_s}=2$, $\frac{b_w}{r_w}=2$, $\frac{b_w}{b_s}=0.2$, $b_w=0.2$ in., $E=10.7 \times 10^3$ ksi, and $\mu=0.32$.

(15) and are plotted in figures 6 and 7. The lowest curve in each graph is obtained from the lower-limit assumption, $\beta=0$; the highest curve gives calculated upper-limit values based on the use of equations (80) and (81) in calculating α_{UL} and β_{UL} ; the middle (dashed) curve shows the results obtainable by using for α and β values determined experimentally on specimens like those in figure 5. In each case it was assumed that $\beta'=\beta$, and α' was computed from equations (93) and (94). Table I summarizes the upper-limit and experimental values of α and β used for these calculations.

In general, figures 6 and 7 indicate that the agreement between calculation and experiment is within the experimental scatter, with the calculations based on the values α_{exp} and β_{exp} giving the best results.

CONCLUDING REMARKS

On the basis of an idealization of integrally stiffened plates to more uniform plates resembling plywood, formulas have

TABLE I.

VALUES OF α , α' , β , AND β' USED IN THE CALCULATION OF THE ELASTIC CONSTANTS FOR COMPARISON WITH EXPERIMENTAL MEASUREMENTS OF E_1 , G_k , D_x , AND D_{xy}

b_w/t_s	α_{exp}	α_{UL}	$\alpha'_{\beta'=\beta_{exp}}$	$\alpha'_{\beta'=\beta_{UL}}$	β_{exp}	β_{UL}
$b_w/b_s=0.2$ (a)						
1	0.24	0.25	0.45	0.25	0.20	0.53
2	.17	.15	.33	.24	.23	.45
4	.12	.085	.43	.31	.14	.29
8	.004	.046	.53	.43	.12	.19
$b_w/b_s=0.4$ (b)						
4	---	0.14	-----	0.44	---	0.14

^a These values (computed from eqs. (74), (77), (80), (81), (93), and (94)) were used for calculating constants for all configurations given in figures 6 and 7 except those for which $\theta=0^\circ$ and $\theta=90^\circ$ (one-way stiffening).

^b These values (computed from eqs. (74), (77), (81), (87), (93), and (94)) were used for calculating constants for configurations of figure 6 having $\theta=0^\circ$ and $\theta=90^\circ$.

been derived for the elastic constants of the plates with integral ribbing in one or more directions. Two sets of elastic-constant formulas have been given, based on two different forms of the force-distortion equations.

The formulas for the elastic constants involve four coefficients α , β , α' , and β' for each rib which define the effectiveness of the rib in resisting stretching and bending in its transverse direction, horizontal shearing, and twisting. Experimental means of determining these coefficients are discussed, as are theoretical methods of obtaining values corresponding to lower-limit or upper-limit assumptions regarding the stiffness of the plate.

The predictions of the formulas for four of the elastic constants are compared with experiment and good correlation is obtained when experimentally determined values (or, in most cases, upper-limit values) of α and β are used in the formulas for the elastic constants. Despite experimental scatter, the calculations and experiments agree, in general, both in magnitude and in regard to trends resulting from variation in angle of skew of ribbing or in skin thickness.

LANGLEY AERONAUTICAL LABORATORY,
NATIONAL ADVISORY COMMITTEE FOR AERONAUTICS,
LANGLEY FIELD, VA., May 26, 1953.

APPENDIX A

RELATIONSHIPS BETWEEN NEW AND ORIGINAL ELASTIC CONSTANTS

The relationships between the new and original elastic constants are as follows:

$$D_1 = \frac{D_z}{1 - \mu_x \mu_y} \quad D_z = D_1(1 - \mu_x \mu_y) \quad (\text{A1})$$

$$D_2 = \frac{D_y}{1 - \mu_x \mu_y} \quad D_y = D_2(1 - \mu_x \mu_y) \quad (\text{A2})$$

$$D_k = \frac{D_{xy}}{2} \quad D_{xy} = 2D_k \quad (\text{A3})$$

$$\left. \begin{aligned} E_1 &= \frac{E_x}{1 - E_x \left[C_{xz} \left(\frac{D_z}{1 - \mu_x \mu_y} \right) (C_{xz} + \mu_y C_{yz}) + C_{yx} \left(\frac{D_y}{1 - \mu_x \mu_y} \right) (C_{yz} + \mu_x C_{xz}) \right]} \\ E_x &= \frac{E_1}{1 + E_1 \left\{ C_{11} \left[\frac{C_{11} - \mu_x C_{21}}{D_1(1 - \mu_x \mu_y)} \right] + C_{21} \left[\frac{C_{21} - \mu_y C_{11}}{D_2(1 - \mu_x \mu_y)} \right] \right\}} \end{aligned} \right\} \quad (\text{A4})$$

$$\left. \begin{aligned} E_2 &= \frac{E_y}{1 - E_y \left[C_{xy} \left(\frac{D_z}{1 - \mu_x \mu_y} \right) (C_{xy} + \mu_y C_{yy}) + C_{yy} \left(\frac{D_y}{1 - \mu_x \mu_y} \right) (C_{yy} + \mu_x C_{xy}) \right]} \\ E_y &= \frac{E_2}{1 + E_2 \left\{ C_{12} \left[\frac{C_{12} - \mu_x C_{22}}{D_1(1 - \mu_x \mu_y)} \right] + C_{22} \left[\frac{C_{22} - \mu_y C_{12}}{D_2(1 - \mu_x \mu_y)} \right] \right\}} \end{aligned} \right\} \quad (\text{A5})$$

$$G_k = \frac{G_{xy}}{1 - 2D_{xy}G_{xy}T^2} \quad G_{xy} = \frac{G_k D_k}{D_k + C_k^2 G_k} \quad (\text{A6})$$

$$\left. \begin{aligned} C_{11} &= C_{xz} \left(\frac{D_z}{1 - \mu_x \mu_y} \right) + \mu_x C_{yz} \left(\frac{D_y}{1 - \mu_x \mu_y} \right) \\ C_{xz} &= \frac{C_{11} - \mu_x C_{21}}{D_1(1 - \mu_x \mu_y)} \end{aligned} \right\} \quad (\text{A7})$$

$$C_{12} = C_{xy} \left(\frac{D_z}{1 - \mu_x \mu_y} \right) + \mu_x C_{yy} \left(\frac{D_y}{1 - \mu_x \mu_y} \right) \quad C_{xy} = \frac{C_{12} - \mu_x C_{22}}{D_1(1 - \mu_x \mu_y)} \quad (\text{A8})$$

$$C_{21} = \mu_y C_{xz} \left(\frac{D_z}{1 - \mu_x \mu_y} \right) + C_{yz} \left(\frac{D_y}{1 - \mu_x \mu_y} \right) \quad C_{yz} = \frac{C_{21} - \mu_y C_{11}}{D_2(1 - \mu_x \mu_y)} \quad (\text{A9})$$

$$C_{22} = \mu_y C_{xy} \left(\frac{D_x}{1 - \mu_x \mu_y} \right) + C_{yy} \left(\frac{D_y}{1 - \mu_x \mu_y} \right) \quad C_{yy} = \frac{C_{22} - \mu_y C_{12}}{D_2 (1 - \mu_x \mu_y)} \quad (\text{A10})$$

$$C_k = -D_{xy} T \quad T = -\frac{C_k}{2D_k} \quad (\text{A11})$$

$$\mu_1 = \mu'_x + \left. \begin{aligned} & \frac{\mu'_x E_x \left[C_{xx} \left(\frac{D_x}{1 - \mu_x \mu_y} \right) (C_{xx} + \mu_y C_{yx}) + C_{yx} \left(\frac{D_y}{1 - \mu_x \mu_y} \right) (C_{yx} + \mu_x C_{xx}) \right] + E_x \left[C_{xx} \left(\frac{D_x}{1 - \mu_x \mu_y} \right) (C_{xy} + \mu_y C_{yy}) + C_{yx} \left(\frac{D_y}{1 - \mu_x \mu_y} \right) (C_{yy} + \mu_x C_{xy}) \right]}{1 - E_x \left[C_{xx} \left(\frac{D_x}{1 - \mu_x \mu_y} \right) (C_{xx} + \mu_y C_{yx}) + C_{yx} \left(\frac{D_y}{1 - \mu_x \mu_y} \right) (C_{yx} + \mu_x C_{xx}) \right]} \\ & \frac{\mu_1 - E_1 \left\{ C_{11} \left[\frac{C_{12} - \mu_x C_{22}}{D_1 (1 - \mu_x \mu_y)} \right] + C_{21} \left[\frac{C_{22} - \mu_y C_{12}}{D_2 (1 - \mu_x \mu_y)} \right] \right\}}{1 + E_1 \left\{ C_{11} \left[\frac{C_{11} - \mu_x C_{21}}{D_1 (1 - \mu_x \mu_y)} \right] + C_{21} \left[\frac{C_{21} - \mu_y C_{11}}{D_2 (1 - \mu_x \mu_y)} \right] \right\}} \end{aligned} \right\} \quad (\text{A12})$$

$$\mu_2 = \mu'_y + \left. \begin{aligned} & \frac{\mu'_y E_y \left[C_{xy} \left(\frac{D_x}{1 - \mu_x \mu_y} \right) (C_{xy} + \mu_y C_{yy}) + C_{yy} \left(\frac{D_y}{1 - \mu_x \mu_y} \right) (C_{yy} + \mu_x C_{xy}) \right] + E_y \left[C_{xy} \left(\frac{D_x}{1 - \mu_x \mu_y} \right) (C_{xx} + \mu_y C_{yx}) + C_{yy} \left(\frac{D_y}{1 - \mu_x \mu_y} \right) (C_{yx} + \mu_x C_{xx}) \right]}{1 - E_y \left[C_{xy} \left(\frac{D_x}{1 - \mu_x \mu_y} \right) (C_{xy} + \mu_y C_{yy}) + C_{yy} \left(\frac{D_y}{1 - \mu_x \mu_y} \right) (C_{yy} + \mu_x C_{xy}) \right]} \\ & \frac{\mu_2 - E_2 \left\{ C_{12} \left[\frac{C_{11} - \mu_x C_{21}}{D_1 (1 - \mu_x \mu_y)} \right] + C_{22} \left[\frac{C_{21} - \mu_y C_{11}}{D_2 (1 - \mu_x \mu_y)} \right] \right\}}{1 + E_2 \left\{ C_{12} \left[\frac{C_{12} - \mu_x C_{22}}{D_1 (1 - \mu_x \mu_y)} \right] + C_{22} \left[\frac{C_{22} - \mu_y C_{12}}{D_2 (1 - \mu_x \mu_y)} \right] \right\}} \end{aligned} \right\} \quad (\text{A13})$$

APPENDIX B

DERIVATION OF FORMULAS FOR ELASTIC CONSTANTS

The basic assumptions of the analysis have already been described. In the derivations that follow, where the word "rib" is used, it means one of the substitute sheets, depending on which property of the rib is under consideration. Separate derivations are given for the constants associated with bending and stretching and those associated with twisting and shear.

CONSTANTS ASSOCIATED WITH BENDING AND STRETCHING

In the derivation of the formulas for the elastic constants associated with bending and stretching, an element of the integrally stiffened plate will be considered; the element has the average prescribed curvatures $\frac{\partial^2 w}{\partial x^2}$ and $\frac{\partial^2 w}{\partial y^2}$ and the strains ϵ_x (measured in some arbitrary plane which will be referred to as plane I) and ϵ_y (measured in some other arbitrary plane which will be referred to as plane II). The development of these prescribed deformations requires the application of moments of intensity M_x and M_y and forces of intensity N_x (acting in plane I) and N_y (acting in plane II). These moments and forces and the locations of planes I and II are shown in figure 8.

If the strains are assumed to vary linearly through the thickness of the element, two horizontal planes can be found (in terms of $\frac{\partial^2 w}{\partial x^2}$, ϵ_x , $\frac{\partial^2 w}{\partial y^2}$, and ϵ_y) in which the x -wise strain and y -wise strain, respectively, are zero. These planes are indicated in figure 9.

Strains of components of plate.—The longitudinal extensional strains of the ribs measured at their cross-sectional centroids can be written in terms of the curvatures and the distance between the rib centroids and the planes of zero extensional strains. The strains of the x -wise, y -wise, and

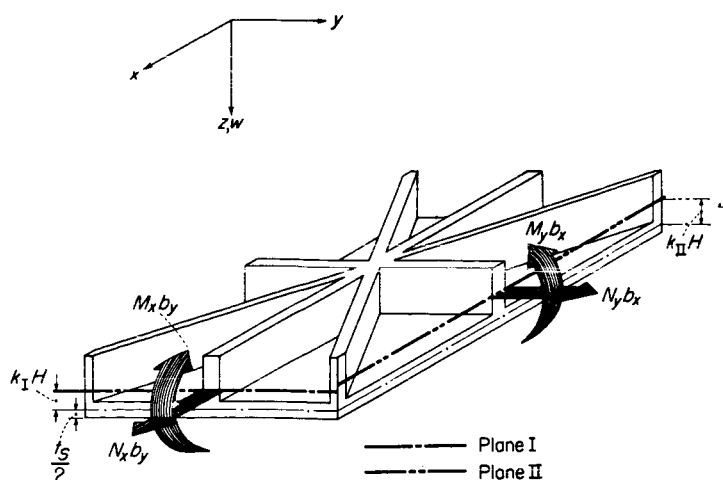

FIGURE 8.—Forces and moments considered for analysis of bending and stretching.

skewed ribs are, respectively,

$$\epsilon_{w_{xL}} = h_3 \frac{\partial^2 w}{\partial x^2} \quad (\text{B1})$$

$$\epsilon_{w_{yL}} = k_3 \frac{\partial^2 w}{\partial y^2} \quad (\text{B2})$$

$$\epsilon_{w_{sL}} = h_1 \frac{\partial^2 w}{\partial x^2} \cos^2 \theta + k_1 \frac{\partial^2 w}{\partial y^2} \sin^2 \theta \quad (\text{B3})$$

where the subscript L denotes longitudinal direction of a rib, the subscript x the x -wise rib, the subscript y the y -wise rib, and the subscript s the skew rib. The distances h_3 , k_3 , h_1 , and k_1 are shown in figure 9.

The transverse strains of the ribs are as follows:

$$\epsilon_{w_{xT}} = -(k_2 - \alpha_x H) \frac{\partial^2 w}{\partial y^2} \quad (\text{B4})$$

$$\epsilon_{w_{yT}} = -(h_2 - \alpha_y H) \frac{\partial^2 w}{\partial x^2} \quad (\text{B5})$$

$$\epsilon_{w_{sT}} = -(h_2 - \alpha_s H) \frac{\partial^2 w}{\partial x^2} \sin^2 \theta - (k_2 - \alpha_s H) \frac{\partial^2 w}{\partial y^2} \cos^2 \theta \quad (\text{B6})$$

The extensional strains of the sheet midplane in terms of the curvatures are

$$\epsilon_{s_x} = -h_2 \frac{\partial^2 w}{\partial x^2} \quad (\text{B7})$$

$$\epsilon_{s_y} = -k_2 \frac{\partial^2 w}{\partial y^2} \quad (\text{B8})$$

The curvatures $\frac{\partial^2 w}{\partial x^2}$ and $\frac{\partial^2 w}{\partial y^2}$ of the element are also the cur-

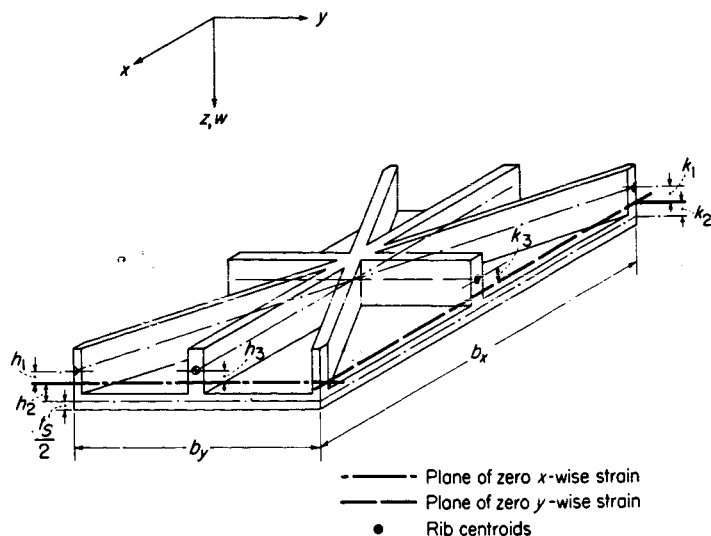

FIGURE 9.—Dimensions for analysis of bending and stretching.

vatures of the x -wise and y -wise ribs, respectively. The curvature of the skew ribs is

$$\frac{\partial^2 w}{\partial s^2} = \frac{\partial^2 w}{\partial x^2} \cos^2 \theta + \frac{\partial^2 w}{\partial y^2} \sin^2 \theta \quad (\text{B9})$$

The horizontal shear strain in one of the skew ribs, relative to the longitudinal and transverse directions of the rib, can be written in terms of the x -wise and y -wise strains at the same level, which in turn are determined by the x -wise and y -wise curvatures; thus,

$$\gamma_{w_s} = 2 \left[-(h_2 - \alpha' H) \frac{\partial^2 w}{\partial x^2} + (k_2 - \alpha' H) \frac{\partial^2 w}{\partial y^2} \right] \sin \theta \cos \theta \quad (\text{B10})$$

The x -wise and y -wise ribs have no shear strain.

Expressions for the dimensions h_1 , h_2 , h_3 , k_1 , k_2 , and k_3 .—In the derivation of equations (B1) to (B8) and of equation (B10), the assumption was made that the strains varied linearly from the planes of zero strain. On the basis of the same assumption, expressions are written for the strains in planes I and II—the planes in which N_x and N_y act and in which ϵ_x and ϵ_y are measured. These expressions are

$$\epsilon_x = -(h_2 - k_I H) \frac{\partial^2 w}{\partial x^2} \quad (\text{B11})$$

$$\epsilon_y = -(k_2 - k_{II} H) \frac{\partial^2 w}{\partial y^2} \quad (\text{B12})$$

from which

$$h_2 = k_I H - \frac{\epsilon_x}{\frac{\partial^2 w}{\partial x^2}} \quad (\text{B13})$$

$$k_2 = k_{II} H - \frac{\epsilon_y}{\frac{\partial^2 w}{\partial y^2}} \quad (\text{B14})$$

By geometry the dimensions h_1 , h_3 , k_1 , and k_3 may be written

$$h_1 = \bar{k}_{w_x} H - h_2 \quad (\text{B15})$$

$$h_3 = \bar{k}_{w_x} H - h_2 \quad (\text{B16})$$

$$k_1 = \bar{k}_{w_x} H - k_2 \quad (\text{B17})$$

$$k_3 = \bar{k}_{w_y} H - k_2 \quad (\text{B18})$$

where $\bar{k}_{w_x} H$, $\bar{k}_{w_y} H$, $\bar{k}_{w_s} H$ locate the centroidal axes of the ribs from the center line of the sheet. Substituting for h_2

and k_2 from equations (B13) and (14) gives

$$h_1 = (\bar{k}_{w_x} - k_I) H + \frac{\epsilon_x}{\frac{\partial^2 w}{\partial x^2}} \quad (\text{B19})$$

$$h_3 = (\bar{k}_{w_x} - k_I) H + \frac{\epsilon_x}{\frac{\partial^2 w}{\partial x^2}} \quad (\text{B20})$$

$$k_1 = (\bar{k}_{w_x} - k_{II}) H + \frac{\epsilon_y}{\frac{\partial^2 w}{\partial y^2}} \quad (\text{B21})$$

$$k_3 = (\bar{k}_{w_y} - k_{II}) H + \frac{\epsilon_y}{\frac{\partial^2 w}{\partial y^2}} \quad (\text{B22})$$

Evaluation of strain energy.—The total strain energy of the element of the integrally stiffened plate can be written as the sum of the strain energies of its component parts; thus

$$\begin{aligned} V = & \frac{1}{2} \int_0^{b_x} \epsilon_{w_{xL}}^2 E A_{w_x} dx + \frac{1}{2} \int_0^{b_y} \epsilon_{w_{yL}}^2 E A_{w_y} dy + \\ & \frac{1}{2} \int_0^{b_x \text{ sec } \theta} \epsilon_{w_{xL}}^2 E A_{w_x} ds + \frac{1}{2} \int_0^{b_x} \epsilon_{w_{xT}}^2 E \beta_x A_{w_x} dx + \\ & \frac{1}{2} \int_0^{b_y} \epsilon_{w_{yT}}^2 E \beta_y A_{w_y} dy + \frac{1}{2} \int_0^{b_x \text{ sec } \theta} \epsilon_{w_{yT}}^2 E \beta_x A_{w_x} ds + \\ & \frac{1}{2} \int_0^{b_x \text{ sec } \theta} \gamma_{w_s}^2 G \beta'_s A_{w_s} ds + \frac{1}{2} \int_0^{b_x} \int_0^{b_y} (\epsilon_{s_x}^2 + \epsilon_{s_y}^2 + 2\mu \epsilon_{s_x} \epsilon_{s_y}) \\ & \frac{E}{1-\mu^2} t_s dx dy + \frac{1}{2} \int_0^{b_x} \left(\frac{\partial^2 w}{\partial x^2} \right)^2 E I_{w_x} dx + \frac{1}{2} \int_0^{b_y} \left(\frac{\partial^2 w}{\partial y^2} \right)^2 E I_{w_y} dy + \\ & \frac{1}{2} \int_0^{b_x \text{ sec } \theta} \left(\frac{\partial^2 w}{\partial s^2} \right)^2 E I_{w_s} ds + \frac{1}{2} \int_0^{b_x} \int_0^{b_y} \left[\left(\frac{\partial^2 w}{\partial x^2} \right)^2 + \left(\frac{\partial^2 w}{\partial y^2} \right)^2 + \right. \\ & \left. 2\mu \frac{\partial^2 w}{\partial x^2} \frac{\partial^2 w}{\partial y^2} \right] \frac{E}{1-\mu^2} \frac{t_s^3}{12} dx dy \quad (\text{B23}) \end{aligned}$$

In equation (B23) the first three terms give the energy of extension of the ribs in their longitudinal directions, the second three terms the energy of extension of the ribs in their transverse directions, the seventh term the energy associated with the shearing of the ribs, and the eighth term the energy of extension of the skin. The next three terms give the energy of bending of the ribs, and the final term gives the energy of bending of the skin.

Carrying out the integrations of equation (B23), dividing

by $b_x b_y$ to reduce the result to strain energy per unit area, and substituting the previously derived expressions for the distortions ϵ_{w_x} , ϵ_{w_y} , and so forth gives

$$\frac{V}{b_x b_y} = V'$$

$$\begin{aligned}
 &= \frac{E}{2} \left(\left[\frac{1}{1-\mu^2} t_s + \frac{A_{w_x}}{b_y} + \beta_y \frac{A_{w_y}}{b_x} + \frac{A_{w_s}}{b_s} \left(\cos^4 \theta + \beta_s \sin^4 \theta + \beta'_s \frac{2}{1+\mu} \sin^2 \theta \cos^2 \theta \right) \right] \epsilon_x^2 + 2 \left[\frac{\mu}{1-\mu^2} t_s + \frac{A_{w_s}}{b_s} \left(\sin^2 \theta \cos^2 \theta + \right. \right. \right. \\
 &\quad \left. \left. \left. \beta_s \sin^2 \theta \cos^2 \theta - \beta'_s \frac{2}{1+\mu} \sin^2 \theta \cos^2 \theta \right) \right] \epsilon_x \epsilon_y + 2 \left\{ \frac{-1}{1-\mu^2} t_s (k_{II} H) + \frac{A_{w_x}}{b_y} (\bar{k}_{w_x} - k_I) H + \beta_y \frac{A_{w_y}}{b_x} (\alpha_y - k_I) H + \frac{A_{w_s}}{b_s} \left[(\bar{k}_{w_s} - k_{II}) H \cos^4 \theta + \right. \right. \right. \\
 &\quad \left. \left. \left. \beta_s (\alpha_s - k_{II}) H \sin^4 \theta + \beta'_s (\alpha'_s - k_{II}) H \left(\frac{2}{1+\mu} \sin^2 \theta \cos^2 \theta \right) \right] \right\} \epsilon_x \frac{\partial^2 w}{\partial x^2} + 2 \left\{ \frac{-\mu}{1-\mu^2} t_s (k_{II} H) + \frac{A_{w_s}}{b_s} \left[(\bar{k}_{w_s} - k_{II}) H \sin^2 \theta \cos^2 \theta + \right. \right. \\
 &\quad \left. \left. \beta_s (\alpha_s - k_{II}) H \sin^2 \theta \cos^2 \theta - \beta'_s (\alpha'_s - k_{II}) H \left(\frac{2}{1+\mu} \sin^2 \theta \cos^2 \theta \right) \right] \right\} \epsilon_x \frac{\partial^2 w}{\partial y^2} + \left[\frac{1}{1-\mu^2} t_s + \beta_x \frac{A_{w_x}}{b_y} + \frac{A_{w_y}}{b_x} + \right. \\
 &\quad \left. \frac{A_{w_s}}{b_s} \left(\sin^4 \theta + \beta_s \cos^4 \theta + \beta'_s \frac{2}{1+\mu} \sin^2 \theta \cos^2 \theta \right) \right] \epsilon_y^2 + 2 \left\{ \frac{-\mu}{1-\mu^2} t_s (k_{II} H) + \frac{A_{w_s}}{b_s} (\bar{k}_{w_s} - k_I) H \sin^2 \theta \cos^2 \theta + \beta_s (\alpha_s - k_I) H \sin^2 \theta \cos^2 \theta - \right. \\
 &\quad \left. \beta'_s (\alpha'_s - k_I) H \left(\frac{2}{1+\mu} \sin^2 \theta \cos^2 \theta \right) \right\} \epsilon_y \frac{\partial^2 w}{\partial x^2} + 2 \left\{ \frac{-1}{1-\mu^2} t_s (k_{II} H) + \beta_x \frac{A_{w_x}}{b_y} (\alpha_x - k_{II}) H + \frac{A_{w_y}}{b_x} (\bar{k}_{w_y} - k_{II}) H + \right. \\
 &\quad \left. \frac{A_{w_s}}{b_s} \left[(\bar{k}_{w_s} - k_{II}) H \sin^4 \theta + \beta_s (\alpha_s - k_{II}) H \cos^4 \theta + \beta'_s (\alpha'_s - k_{II}) H \left(\frac{2}{1+\mu} \sin^2 \theta \cos^2 \theta \right) \right] \right\} \epsilon_y \frac{\partial^2 w}{\partial y^2} + \left\{ \frac{1}{12(1-\mu^2)} t_s^3 + \right. \\
 &\quad \left. \frac{I_{w_x}}{b_y} + \frac{I_{w_s}}{b_s} \cos^4 \theta + \frac{1}{1-\mu^2} t_s (k_{II} H)^2 + \frac{A_{w_x}}{b_y} (\bar{k}_{w_x} - k_I)^2 H^2 + \beta_y \frac{A_{w_y}}{b_x} (\alpha_y - k_I)^2 H^2 + \frac{A_{w_s}}{b_s} \left[(\bar{k}_{w_s} - k_I)^2 H^2 \cos^4 \theta + \beta_s (\alpha_s - k_I)^2 H^2 \sin^4 \theta + \right. \right. \\
 &\quad \left. \left. \beta'_s (\alpha'_s - k_I)^2 H^2 \left(\frac{2}{1+\mu} \sin^2 \theta \cos^2 \theta \right) \right] \right\} \left(\frac{\partial^2 w}{\partial x^2} \right)^2 + 2 \left\{ \frac{\mu}{12(1-\mu^2)} t_s^3 + \frac{I_{w_s}}{b_s} \sin^2 \theta \cos^2 \theta + \frac{\mu}{1-\mu^2} t_s (k_I k_{II} H^2) + \right. \\
 &\quad \left. \frac{A_{w_s}}{b_s} \left[(\bar{k}_{w_s} - k_I) (\bar{k}_{w_s} - k_{II}) H^2 \sin^2 \theta \cos^2 \theta + \beta_s (\alpha_s - k_I) (\alpha_s - k_{II}) H^2 \sin^2 \theta \cos^2 \theta - \right. \right. \\
 &\quad \left. \left. \beta'_s (\alpha'_s - k_I) (\alpha'_s - k_{II}) H^2 \left(\frac{2}{1+\mu} \sin^2 \theta \cos^2 \theta \right) \right] \right\} \frac{\partial^2 w}{\partial x^2} \frac{\partial^2 w}{\partial y^2} + \left\{ \frac{1}{12(1-\mu^2)} t_s^3 + \frac{I_{w_y}}{b_x} + \frac{I_{w_s}}{b_s} \sin^4 \theta + \frac{1}{1-\mu^2} t_s (k_{II} H)^2 + \right. \\
 &\quad \left. \beta_x \frac{A_{w_x}}{b_y} (\alpha_x - k_{II})^2 H^2 + \frac{A_{w_y}}{b_x} (\bar{k}_{w_y} - k_{II})^2 H^2 + \frac{A_{w_s}}{b_s} \left[(\bar{k}_{w_s} - k_{II})^2 H^2 \sin^4 \theta + \beta_s (\alpha_s - k_{II})^2 H^2 \cos^4 \theta + \right. \right. \\
 &\quad \left. \left. \beta'_s (\alpha'_s - k_{II})^2 H^2 \left(\frac{2}{1+\mu} \sin^2 \theta \cos^2 \theta \right) \right] \right\} \left(\frac{\partial^2 w}{\partial y^2} \right)^2 \tag{B24}
 \end{aligned}$$

where the identities $\frac{1}{b_x} = \frac{1}{b_s} \sin \theta$ and $\frac{1}{b_y} = \frac{1}{b_s} \cos \theta$ have been substituted to simplify the expressions.

Invoking the principle of virtual displacements by differentiating the energy expression (B24) with respect to each

of the strains and curvatures and dividing by EH or EH^2 gives the following expressions for the forces and moments:

$$\begin{aligned} \frac{\partial V'}{\partial \epsilon_x} \frac{1}{EH} &= \frac{N_x}{EH} \\ &= \left[\frac{1}{1-\mu^2} \frac{t_s}{H} + \frac{A_{w_x}/b_y}{H} + \beta_y \frac{A_{w_y}/b_x}{H} + \frac{A_{w_s}/b_s}{H} \left(\cos^4 \theta + \beta_s \sin^4 \theta + \beta'_s \frac{2}{1+\mu} \sin^2 \theta \cos^2 \theta \right) \right] \epsilon_x + \left[\frac{\mu}{1-\mu^2} \frac{t_s}{H} + \frac{A_{w_s}/b_s}{H} \left(\sin^2 \theta \cos^2 \theta + \right. \right. \\ &\quad \left. \left. \beta_s \sin^2 \theta \cos^2 \theta - \beta'_s \frac{2}{1+\mu} \sin^2 \theta \cos^2 \theta \right) \right] \epsilon_y + \left\{ \frac{-1}{1-\mu^2} \frac{t_s}{H} k_{I1} + \frac{A_{w_x}/b_y}{H} (\bar{k}_{w_x} - k_{I1}) + \beta_y \frac{A_{w_y}/b_x}{H} (\alpha_y - k_{I1}) + \right. \\ &\quad \left. \frac{A_{w_s}/b_s}{H} \left[(\bar{k}_{w_s} - k_{I1}) \cos^4 \theta + \beta_s (\alpha_s - k_{I1}) \sin^4 \theta + \beta'_s (\alpha'_s - k_{I1}) \left(\frac{2}{1+\mu} \sin^2 \theta \cos^2 \theta \right) \right] \right\} H \frac{\partial^2 w}{\partial x^2} + \left\{ \frac{-\mu}{1-\mu^2} \frac{t_s}{H} k_{II} + \right. \\ &\quad \left. \frac{A_{w_s}/b_s}{H} \left[(\bar{k}_{w_s} - k_{II}) \sin^2 \theta \cos^2 \theta + \beta_s (\alpha_s - k_{II}) \sin^2 \theta \cos^2 \theta - \beta'_s (\alpha'_s - k_{II}) \left(\frac{2}{1+\mu} \sin^2 \theta \cos^2 \theta \right) \right] \right\} H \frac{\partial^2 w}{\partial y^2} \end{aligned} \quad (B25)$$

$$\begin{aligned} \frac{\partial V'}{\partial \epsilon_y} \frac{1}{EH} &= \frac{N_y}{EH} \\ &= \left[\frac{\mu}{1-\mu^2} \frac{t_s}{H} + \frac{A_{w_s}/b_s}{H} \left(\sin^2 \theta \cos^2 \theta + \beta_s \sin^2 \theta \cos^2 \theta - \beta'_s \frac{2}{1+\mu} \sin^2 \theta \cos^2 \theta \right) \right] \epsilon_x + \left[\frac{1}{1-\mu^2} \frac{t_s}{H} + \beta_x \frac{A_{w_x}/b_y}{H} + \frac{A_{w_y}/b_x}{H} + \right. \\ &\quad \left. \frac{A_{w_s}/b_s}{H} \left(\sin^4 \theta + \beta_s \cos^4 \theta + \beta'_s \frac{2}{1+\mu} \sin^2 \theta \cos^2 \theta \right) \right] \epsilon_y + \left\{ \frac{-\mu}{1-\mu^2} \frac{t_s}{H} k_{I1} + \frac{A_{w_s}/b_s}{H} \left[(\bar{k}_{w_s} - k_{I1}) \sin^2 \theta \cos^2 \theta + \right. \right. \\ &\quad \left. \left. \beta_s (\alpha_s - k_{I1}) \sin^2 \theta \cos^2 \theta - \beta'_s (\alpha'_s - k_{I1}) \left(\frac{2}{1+\mu} \sin^2 \theta \cos^2 \theta \right) \right] \right\} H \frac{\partial^2 w}{\partial x^2} + \left\{ \frac{-1}{1-\mu^2} \frac{t_s}{H} k_{II} + \beta_x \frac{A_{w_x}/b_y}{H} (\alpha_x - k_{II}) + \right. \\ &\quad \left. \frac{A_{w_y}/b_x}{H} (\bar{k}_{w_y} - k_{II}) + \frac{A_{w_s}/b_s}{H} \left[(\bar{k}_{w_s} - k_{II}) \sin^4 \theta + \beta_s (\alpha_s - k_{II}) \cos^4 \theta + \beta'_s (\alpha'_s - k_{II}) \left(\frac{2}{1+\mu} \sin^2 \theta \cos^2 \theta \right) \right] \right\} H \frac{\partial^2 w}{\partial y^2} \end{aligned} \quad (B26)$$

$$\begin{aligned} \frac{\partial V'}{\partial \frac{\partial^2 w}{\partial x^2}} \frac{1}{EH^2} &= -\frac{M_x}{EH^2} \\ &= \left\{ \frac{-1}{1-\mu^2} \frac{t_s}{H} k_{I1} + \frac{A_{w_x}/b_y}{H} (\bar{k}_{w_x} - k_{I1}) + \beta_y \frac{A_{w_y}/b_x}{H} (\alpha_y - k_{I1}) + \frac{A_{w_s}/b_s}{H} \left[(\bar{k}_{w_s} - k_{I1}) \cos^4 \theta + \beta_s (\alpha_s - k_{I1}) \sin^4 \theta + \right. \right. \\ &\quad \left. \left. \beta'_s (\alpha'_s - k_{I1}) \left(\frac{2}{1+\mu} \sin^2 \theta \cos^2 \theta \right) \right] \right\} \epsilon_x + \left\{ \frac{-\mu}{1-\mu^2} \frac{t_s}{H} k_{I1} + \frac{A_{w_s}/b_s}{H} \left[(\bar{k}_{w_s} - k_{I1}) \sin^2 \theta \cos^2 \theta + \beta_s (\alpha_s - k_{I1}) \sin^2 \theta \cos^2 \theta - \right. \right. \\ &\quad \left. \left. \beta'_s (\alpha'_s - k_{I1}) \left(\frac{2}{1+\mu} \sin^2 \theta \cos^2 \theta \right) \right] \right\} \epsilon_y + \left\{ \frac{1}{12(1-\mu^2)} \left(\frac{t_s}{H} \right)^3 + \frac{I_{w_x}/b_y}{H^3} + \frac{I_{w_s}/b_s}{H^3} \cos^4 \theta + \frac{1}{1-\mu^2} \frac{t_s}{H} k_{I1}^2 + \frac{A_{w_x}/b_y}{H} (\bar{k}_{w_x} - k_{I1})^2 + \right. \\ &\quad \left. \beta_y \frac{A_{w_y}/b_x}{H} (\alpha_y - k_{I1})^2 + \frac{A_{w_s}/b_s}{H} \left[(\bar{k}_{w_s} - k_{I1})^2 \cos^4 \theta + \beta_s (\alpha_s - k_{I1})^2 \sin^4 \theta + \beta'_s (\alpha'_s - k_{I1})^2 \left(\frac{2}{1+\mu} \sin^2 \theta \cos^2 \theta \right) \right] \right\} H \frac{\partial^2 w}{\partial x^2} + \\ &\quad \left\{ \frac{\mu}{12(1-\mu^2)} \left(\frac{t_s}{H} \right)^3 + \frac{I_{w_s}/b_s}{H^3} \sin^2 \theta \cos^2 \theta + \frac{\mu}{1-\mu^2} \frac{t_s}{H} k_{I1} k_{II} + \frac{A_{w_s}/b_s}{H} \left[(\bar{k}_{w_s} - k_{I1}) (\bar{k}_{w_s} - k_{II}) \sin^2 \theta \cos^2 \theta + \right. \right. \\ &\quad \left. \left. \beta_s (\alpha_s - k_{I1}) (\alpha_s - k_{II}) \sin^2 \theta \cos^2 \theta - \beta'_s (\alpha'_s - k_{I1}) (\alpha'_s - k_{II}) \left(\frac{2}{1+\mu} \sin^2 \theta \cos^2 \theta \right) \right] \right\} H \frac{\partial^2 w}{\partial y^2} \end{aligned} \quad (B27)$$

$$\begin{aligned}
 \frac{\partial V'}{\partial \frac{\partial^2 w}{\partial y^2}} \frac{1}{EH^2} &= -\frac{M_y}{EH^2} \\
 &= \left\{ \frac{-\mu}{1-\mu^2} \frac{t_s}{H} k_{II} + \frac{A_{w_s}/b_s}{H} \left[(\bar{k}_{w_s} - k_{II}) \sin^2 \theta \cos^2 \theta + \beta_s (\alpha_s - k_{II}) \sin^2 \theta \cos^2 \theta - \beta'_s (\alpha'_s - k_{II}) \left(\frac{2}{1+\mu} \sin^2 \theta \cos^2 \theta \right) \right] \right\} \epsilon_x + \\
 &\quad \left\{ \frac{-1}{1-\mu^2} \frac{t_s}{H} k_{II} + \beta_x \frac{A_{w_x}/b_x}{H} (\alpha_x - k_{II}) + \frac{A_{w_y}/b_y}{H} (\bar{k}_{w_y} - k_{II}) + \frac{A_{w_s}/b_s}{H} \left[(\bar{k}_{w_s} - k_{II}) \sin^4 \theta + \beta_s (\alpha_s - k_{II}) \cos^4 \theta + \right. \right. \\
 &\quad \left. \left. \beta'_s (\alpha'_s - k_{II}) \left(\frac{2}{1+\mu} \sin^2 \theta \cos^2 \theta \right) \right] \right\} \epsilon_y + \left\{ \frac{\mu}{12(1+\mu^2)} \left(\frac{t_s}{H} \right)^3 + \frac{I_{w_s}/b_s}{H^3} \sin^2 \theta \cos^2 \theta + \frac{\mu}{1-\mu^2} \frac{t_s}{H} k_I k_{II} + \right. \\
 &\quad \frac{A_{w_s}/b_s}{H} \left[(\bar{k}_{w_s} - k_I) (\bar{k}_{w_s} - k_{II}) \sin^2 \theta \cos^2 \theta + \beta_s (\alpha_s - k_I) (\alpha_s - k_{II}) \sin^2 \theta \cos^2 \theta - \right. \\
 &\quad \left. \beta'_s (\alpha'_s - k_I) (\alpha'_s - k_{II}) \left(\frac{2}{1+\mu} \sin^2 \theta \cos^2 \theta \right) \right] \right\} H \frac{\partial^2 w}{\partial x^2} + \left\{ \frac{1}{12(1-\mu^2)} \left(\frac{t_s}{H} \right)^3 + \frac{I_{w_y}/b_x}{H^3} + \frac{I_{w_s}/b_s}{H^3} \sin^4 \theta + \frac{1}{1-\mu^2} \frac{t_s}{H} (k_{II})^2 + \right. \\
 &\quad \left. \beta_x \frac{A_{w_x}/b_y}{H} (\alpha_x - k_{II})^2 + \frac{A_{w_y}/b_x}{H} (\bar{k}_{w_y} - k_{II})^2 + \frac{A_{w_s}/b_s}{H} \left[(\bar{k}_{w_s} - k_{II})^2 \sin^4 \theta + \right. \right. \\
 &\quad \left. \left. \beta_s (\alpha_s - k_{II})^2 \cos^4 \theta + \beta'_s (\alpha'_s - k_{II})^2 \left(\frac{2}{1+\mu} \sin^2 \theta \cos^2 \theta \right) \right] \right\} H \frac{\partial^2 w}{\partial y^2} \tag{B28}
 \end{aligned}$$

The equations for N_x , N_y , M_x , and M_y (eqs. (B25) to (B28)) can be written as

$$\frac{N_x}{EH} = A_x \epsilon_x + A_s \epsilon_y + A_z (\bar{k}_x - k_I) H \frac{\partial^2 w}{\partial x^2} + A_s (\bar{k}_s - k_{II}) H \frac{\partial^2 w}{\partial y^2} \tag{B29}$$

$$\frac{N_y}{EH} = A_s \epsilon_x + A_y \epsilon_y + A_s (\bar{k}_s - k_I) H \frac{\partial^2 w}{\partial x^2} + A_y (\bar{k}_y - k_{II}) H \frac{\partial^2 w}{\partial y^2} \tag{B30}$$

$$\begin{aligned}
 -\frac{M_x}{EH^2} &= A_x (\bar{k}_x - k_I) \epsilon_x + A_s (\bar{k}_s - k_I) \epsilon_y + [I_x + A_x (\bar{k}_x - k_I)^2] H \frac{\partial^2 w}{\partial x^2} + \\
 &\quad [I_s + A_s (\bar{k}_s - k_I) (\bar{k}_s - k_{II})] H \frac{\partial^2 w}{\partial y^2} \tag{B31}
 \end{aligned}$$

$$\begin{aligned}
 -\frac{M_y}{EH^2} &= A_s (\bar{k}_s - k_{II}) \epsilon_x + A_y (\bar{k}_y - k_{II}) \epsilon_y + \\
 &\quad [I_s + A_s (\bar{k}_s - k_I) (\bar{k}_s - k_{II})] H \frac{\partial^2 w}{\partial x^2} + \\
 &\quad [I_y + A_y (\bar{k}_y - k_{II})^2] H \frac{\partial^2 w}{\partial y^2} \tag{B32}
 \end{aligned}$$

where A_x , A , and so forth are given in equations (43) to (54).

In order to identify the desired elastic constants associated with extension and bending, the foregoing force-distortion relationships, equations (B29) to (B32), need only to be put into the form of equations (1), (2), (4), and (5) or equations (7), (8), (10), and (11).

CONSTANTS ASSOCIATED WITH TWISTING AND SHEARING

The derivation of the formulas for the elastic constants associated with twisting and shearing is a parallel one to that

for the bending and stretching constants.

An element of the integrally stiffened plate which has the average prescribed twist $\frac{\partial^2 w}{\partial x \partial y}$ and shear strain γ_{xy} (measured in some arbitrary plane which is referred to as plane III) is considered. These prescribed deformations can be effected by the application of twisting moments of intensity M_{xy} and shearing forces of intensity N_{xy} (acting in plane III) to the element. (See fig. 10.)

If the horizontal shear strain is assumed to vary linearly through the thickness, the horizontal plane can be found

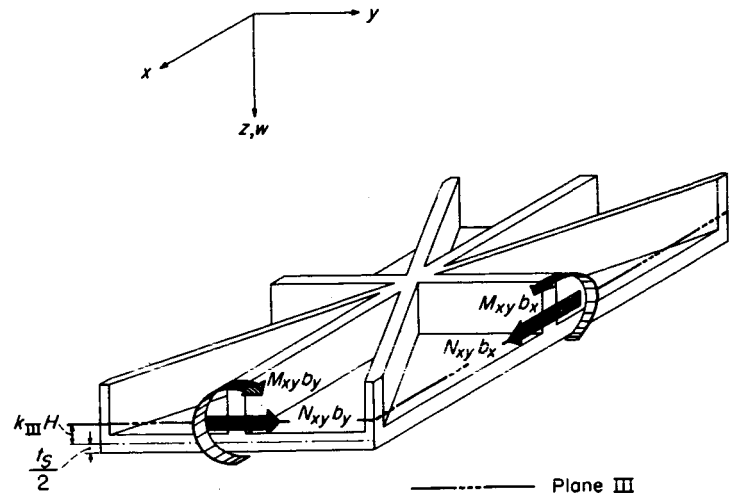

FIGURE 10.—Shears and moments considered for analysis of twisting and shearing.

(in terms of $\frac{\partial^2 w}{\partial x \partial y}$ and γ_{xy}) which has zero shear strain.

This plane is shown in figure 11.

Strains of components of plate.—The extensional strains of the longitudinal, transverse, and one of the skew ribs in their longitudinal directions at their centroids are

$$\epsilon_{w_{zL}} = 0 \quad (\text{B33})$$

$$\epsilon_{w_{yL}} = 0 \quad (\text{B34})$$

$$\epsilon_{w_{xL}} = \pm h'_1 \frac{\partial^2 w}{\partial x \partial y} \sin 2\theta \quad (\text{B35})$$

The transverse strains of the ribs are

$$\epsilon_{w_{xT}} = 0 \quad (\text{B36})$$

$$\epsilon_{w_{yT}} = 0 \quad (\text{B37})$$

$$\epsilon_{w_{zT}} = \pm (h'_2 - \alpha_s H) \frac{\partial^2 w}{\partial x \partial y} \sin 2\theta \quad (\text{B38})$$

The extensional strains of the sheet are

$$\epsilon_{s_x} = 0 \quad (\text{B39})$$

$$\epsilon_{s_y} = 0 \quad (\text{B40})$$

The twist $\frac{\partial^2 w}{\partial x \partial y}$ causes bending of the diagonal ribs. The curvature of one of these ribs is given by

$$\frac{\partial^2 w}{\partial s^2} = - \frac{\partial^2 w}{\partial x \partial y} \sin 2\theta \quad (\text{B41})$$

The curvatures of the longitudinal and transverse ribs are

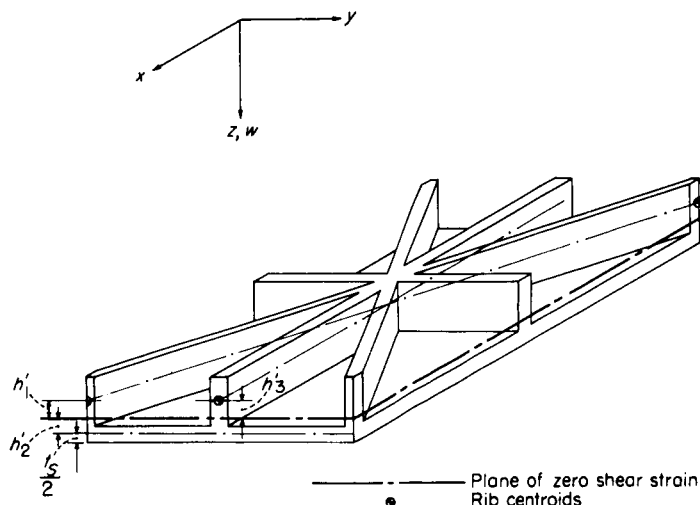

FIGURE 11.—Dimensions for analysis of twisting and shearing.

zero. The shear strain in the skin middle surface is given by

$$\gamma_s = -2h'_2 \frac{\partial^2 w}{\partial x \partial y} \quad (\text{B42})$$

The magnitude of the shear strain of the diagonal ribs is given by

$$\gamma_{w_s} = 2(h'_2 - \alpha'_s H) \frac{\partial^2 w}{\partial x \partial y} \cos 2\theta \quad (\text{B43})$$

The shear strain of the x -wise and y -wise ribs is given by

$$\gamma_{w_x} = -2(h'_2 - \alpha'_x H) \frac{\partial^2 w}{\partial x \partial y} \quad (\text{B44})$$

$$\gamma_{w_y} = -2(h'_2 - \alpha'_y H) \frac{\partial^2 w}{\partial x \partial y} \quad (\text{B45})$$

Expressions for the dimensions h'_1 and h'_2 .—The following expressions can be written for the strains in plane III, in which N_{xy} acts and in which γ_{xy} is measured (see fig. 10):

$$\gamma_{xy} = -2(h'_2 - k_{III} H) \frac{\partial^2 w}{\partial x \partial y} \quad (\text{B46})$$

from which

$$h'_2 = k_{III} H - \frac{1}{2} \frac{\gamma_{xy}}{\frac{\partial^2 w}{\partial x \partial y}} \quad (\text{B47})$$

By geometry

$$h'_1 = \bar{k}_{w_s} H - h'_2 \quad (\text{B48})$$

Substituting for h'_2 from equation (B47) gives

$$h'_1 = (\bar{k}_{w_s} - k_{III}) H + \frac{1}{2} \frac{\gamma_{xy}}{\frac{\partial^2 w}{\partial x \partial y}} \quad (\text{B49})$$

Evaluation of strain energy.—The total strain energy can be written as

$$\begin{aligned} U = & \frac{1}{2} \int_0^{b_x \sec \theta} \epsilon_{w_{zL}}^2 E A_{w_s} ds + \frac{1}{2} \int_0^{b_x \sec \theta} \epsilon_{w_{yT}}^2 E \beta_s A_{w_s} ds + \\ & \frac{1}{2} \int_0^{b_x} \gamma_{w_x}^2 G \beta'_x A_{w_x} dx + \frac{1}{2} \int_0^{b_y} \gamma_{w_y}^2 G \beta'_y A_{w_y} dy + \\ & \frac{1}{2} \int_0^{b_x \sec \theta} \gamma_{w_s}^2 G \beta'_s A_{w_s} ds + \frac{1}{2} \int_0^{b_x} \int_0^{b_y} \gamma_s^2 G t_s dx dy + \\ & \int_0^{b_x} \int_0^{b_y} \left(\frac{\partial^2 w}{\partial x \partial y} \right)^2 G \frac{t_s^3}{6} dx dy + \frac{1}{2} \int_0^{b_x \sec \theta} \left(\frac{\partial^2 w}{\partial s^2} \right)^2 E I_{w_s} ds \quad (\text{B50}) \end{aligned}$$

In equation (B50) the first term gives the energy of extension of the skewed ribs in their longitudinal directions; the second term, the energy of extension of the skewed ribs in their transverse directions; the next three terms, the

energy of shearing of the ribs; and the sixth term, the energy of shearing of the skin. The next term represents the energy of twisting of the skin, and the last term gives the energy of bending of the skew ribs.

Carrying out the integrations of equation (B50), dividing by $b_x b_y$, substituting previously derived expressions, and so forth, gives

$$\begin{aligned}
 \frac{U}{b_x b_y} &= U' \\
 &= \frac{E}{2} \left[\left\{ \frac{1}{2(1+\mu)} t_s + \frac{1}{2(1+\mu)} \beta'_x \frac{A_{w_x}}{b_y} + \frac{1}{2(1+\mu)} \beta'_y \frac{A_{w_y}}{b_x} + \frac{A_{w_s}}{b_s} \left[\sin^2 \theta \cos^2 \theta + \beta_s \sin^2 \theta \cos^2 \theta + \beta'_s \frac{1}{2(1+\mu)} \cos^2 2\theta \right] \right\} \gamma_{xy}^2 + \right. \\
 &4 \left(\frac{-1}{2(1+\mu)} t_s (k_{III} H) + \frac{1}{2(1+\mu)} \beta'_x \frac{A_{w_x}}{b_y} (\alpha'_x - k_{III}) H + \frac{1}{2(1+\mu)} \beta'_y \frac{A_{w_y}}{b_x} (\alpha'_y - k_{III}) H + \frac{A_{w_s}}{b_s} \left\{ (\bar{k}_{w_s} - k_{III}) H \sin^2 \theta \cos^2 \theta + \right. \right. \\
 &\left. \left. \beta_s (\alpha_s - k_{III}) H \sin^2 \theta \cos^2 \theta + \beta'_s (\alpha'_s - k_{III}) H \left[\frac{1}{2(1+\mu)} \cos^2 2\theta \right] \right\} \right) \gamma_{xy} \frac{\partial^2 w}{\partial x \partial y} + \left(\frac{1}{6(1+\mu)} t_s^3 + \right. \\
 &4 \frac{I_{w_s}}{b_s} \sin^2 \theta \cos^2 \theta + \frac{2}{1+\mu} t_s (k_{III} H)^2 + \frac{2}{1+\mu} \beta'_x \frac{A_{w_x}}{b_y} (\alpha'_x - k_{III})^2 H^2 + \frac{2}{1+\mu} \beta'_y \frac{A_{w_y}}{b_x} (\alpha'_y - k_{III})^2 H^2 + \\
 &\left. 4 \frac{A_{w_s}}{b_s} \left\{ (\bar{k}_{w_s} - k_{III})^2 H^2 \sin^2 \theta \cos^2 \theta + \beta_s (\alpha_s - k_{III})^2 H^2 \sin^2 \theta \cos^2 \theta + \beta'_s (\alpha'_s - k_{III})^2 H^2 \left[\frac{1}{2(1+\mu)} \cos^2 2\theta \right] \right\} \right) \left(\frac{\partial^2 w}{\partial x \partial y} \right)^2 \quad (B51)
 \end{aligned}$$

Differentiating the energy expression (B51) with respect to each of the distortions and dividing by EH or EH^2 gives the following expressions for the forces and moments:

$$\begin{aligned}
 \frac{\partial U'}{\partial \gamma_{xy}} \frac{1}{EH} &= \frac{N_{xy}}{EH} \\
 &= \left\{ \frac{1}{2(1+\mu)} \frac{t_s}{H} + \frac{1}{2(1+\mu)} \beta'_x \frac{A_{w_x}/b_y}{H} + \frac{1}{2(1+\mu)} \beta'_y \frac{A_{w_y}/b_x}{H} + \frac{A_{w_s}/b_s}{H} \left[\sin^2 \theta \cos^2 \theta + \beta_s \sin^2 \theta \cos^2 \theta + \right. \right. \\
 &\left. \left. \beta'_s \frac{1}{2(1+\mu)} \cos^2 2\theta \right] \right\} \gamma_{xy} + 2 \left(\frac{-1}{2(1+\mu)} \frac{t_s}{H} k_{III} + \frac{1}{2(1+\mu)} \beta'_x \frac{A_{w_x}/b_y}{H} (\alpha'_x - k_{III}) + \frac{1}{2(1+\mu)} \beta'_y \frac{A_{w_y}/b_x}{H} (\alpha'_y - k_{III}) + \right. \\
 &\left. \frac{A_{w_s}/b_s}{H} \left\{ (\bar{k}_{w_s} - k_{III}) \sin^2 \theta \cos^2 \theta + \beta_s (\alpha_s - k_{III}) \sin^2 \theta \cos^2 \theta + \beta'_s (\alpha'_s - k_{III}) \left[\frac{1}{2(1+\mu)} \cos^2 2\theta \right] \right\} \right) H \frac{\partial^2 w}{\partial x \partial y} \quad (B52)
 \end{aligned}$$

$$\begin{aligned}
 \frac{\partial U'}{\partial \frac{\partial^2 w}{\partial x \partial y}} \frac{1}{EH^2} &= 2 \frac{M_{xy}}{EH^2} \\
 &= 2 \left(\frac{-1}{2(1+\mu)} \frac{t_s}{H} k_{III} + \frac{1}{2(1+\mu)} \beta'_x \frac{A_{w_x}/b_y}{H} (\alpha'_x - k_{III}) + \frac{1}{2(1+\mu)} \beta'_y \frac{A_{w_y}/b_x}{H} (\alpha'_y - k_{III}) + \frac{A_{w_s}/b_s}{H} \left\{ (\bar{k}_{w_s} - k_{III}) \sin^2 \theta \cos^2 \theta + \right. \right. \\
 &\left. \left. \beta_s (\alpha_s - k_{III}) \sin^2 \theta \cos^2 \theta + \beta'_s (\alpha'_s - k_{III}) \left[\frac{1}{2(1+\mu)} \cos^2 2\theta \right] \right\} \right) \gamma_{xy} + \left(\frac{1}{6(1+\mu)} \left(\frac{t_s}{H} \right)^3 + 4 \frac{I_{w_s}/b_s}{H^3} \sin^2 \theta \cos^2 \theta + \frac{2}{1+\mu} \frac{t_s}{H} (k_{III})^2 + \right. \\
 &\left. \frac{2}{1+\mu} \beta'_x \frac{A_{w_x}/b_y}{H} (\alpha'_x - k_{III})^2 + \frac{2}{1+\mu} \beta'_y \frac{A_{w_y}/b_x}{H} (\alpha'_y - k_{III})^2 + 4 \frac{A_{w_s}/b_s}{H} \left\{ (\bar{k}_{w_s} - k_{III})^2 \sin^2 \theta \cos^2 \theta + \right. \right. \\
 &\left. \left. \beta_s (\alpha_s - k_{III})^2 \sin^2 \theta \cos^2 \theta + \beta'_s (\alpha'_s - k_{III})^2 \left[\frac{1}{2(1+\mu)} \cos^2 2\theta \right] \right\} \right) H \frac{\partial^2 w}{\partial x \partial y} \quad (B53)
 \end{aligned}$$

The equations for N_{xy} and M_{xy} (eqs. (B52) and (B53)) can be written as

$$\frac{N_{xy}}{EH} = A_{xy}\gamma_{xy} + 2A_{xy}(\bar{k}_{xy} - k_{III})H \frac{\partial^2 w}{\partial x \partial y} \quad (\text{B54})$$

$$2 \frac{M_{xy}}{EH^2} = 2A_{xy}(\bar{k}_{xy} - k_{III})\gamma_{xy} + [I_{xy} + 4A_{xy}(\bar{k}_{xy} - k_{III})^2]H \frac{\partial^2 w}{\partial x \partial y} \quad (\text{B55})$$

where A_{xy} , \bar{k}_{xy} , and I_{xy} are given in equations (46), (50), and (54), respectively.

Equations (B54) and (B55) may readily be put into the form of equations (6) and (3) or (12) and (9) to yield either the original or the new elastic constants, respectively.

REFERENCES

1. Sandorff, Paul, and Papen, G. W.: Integrally Stiffened Structures. *Aero. Eng. Rev.*, vol. 9, no. 2, Feb. 1950, pp. 30-38.
2. Legg, K. L. C.: Integral Construction—A Survey and an Experiment. *Jour. R.A.S.*, vol. 58, no. 523, July 1954, pp. 485-503; Discussion, p. 504.
3. Allen, Arthur H.: Heavy Presses Near Completion. *Metal Progress*, vol. 66, no. 1, July 1954, pp. 81-85.
4. Anon.: Chemical Milling: Now the "Impossible" *Doesn't* Take Longer. Reprinted from *American Machinist*, Sept. 13, 1954.
5. Dow, Norris F., and Hickman, William A.: Preliminary Experiments on the Elastic Compressive Buckling of Plates With Integral Waffle-Like Stiffening. NACA RM L52E05, 1952.
6. Libove, Charles, and Hubka, Ralph E.: Elastic Constants for Corrugated-Core Sandwich Plates. NACA TN 2289, 1951.
7. Dow, Norris F., Levin, L. Ross, and Troutman, John L.: Elastic Buckling Under Combined Stresses of Flat Plates With Integral Waffle-Like Stiffening. NACA TN 3059, 1954.
8. Crawford, Robert F., and Libove, Charles: Shearing Effectiveness of Integral Stiffening. NACA TN 3443, 1955.
9. Lyse, Inge, and Johnston, Bruce G.: Structural Beams in Torsion. Paper No. 1941, *Trans. Am. Soc. Civil Eng.*, vol. 101, 1936, pp. 857-896.