

## REPORT No. 844

### TANK TESTS TO DETERMINE THE EFFECT ON PLANING-TAIL HULLS OF VARYING LENGTH, WIDTH, AND PLAN-FORM TAPER OF AFTERBODY

By JOHN R. DAWSON, ROBERT C. WALTER, and ELIZABETH S. HAY

#### SUMMARY

Tests were conducted in Langley tank no. 2 on models of an unconventional flying-boat hull called a planing-tail hull to determine the effects on resistance of varying a number of afterbody parameters. The effects of varying length, width, and plan-form taper of the afterbody are presented. Tests were made with afterbodies of two widths, two lengths, and two tapers. In the tests the depth of step and the angle of afterbody keel were held constant.

In general, the planing-tail hulls had much lower resistance than conventional hulls. A typical conventional hull compared with a planing-tail hull had 40 percent greater resistance at the hump speed and from 75 percent to more than 100 percent greater resistance near the get-away speed; but in an actual application of the planing-tail hull the center of gravity would have to be located aft of the step in order to obtain the reduction in resistance at hump speed.

It was concluded that decreasing the width of the afterbody of a planing-tail hull increased the resistance at hump speed, decreased the trimming moments required to obtain best trim, and moved forward the location of the center of gravity required to give best trim at the hump speed. Increasing the length of the afterbody of a planing-tail hull decreased the resistance over almost the whole speed range, reduced the variation of trim with speed, and moved aft the location of the center of gravity required to obtain best trim at the hump speed. Tapering the plan form of the afterbody reduced the resistance over the lower half of the speed range and had little effect on the resistance at high speeds. Plan-form taper also moved forward the location of the center of gravity required to obtain best trim at the hump speed.

#### INTRODUCTION

The NACA flying-boat hull with a pointed step (reference 1) was introduced as a configuration that would have low water resistance at high speeds because of its inherently deep step. The results of preliminary tests made on models with a hull similar to the type used in reference 1, called a planing-tail hull, are presented in reference 2. The NACA planing-tail hull has a pointed-step forebody in combination with a very long afterbody that extends back to the region where the tail surfaces would be attached; thus no tail extension is required. The results from reference 2 showed that the planing-tail hull not only would have the low resistance at high speeds that is characteristic of the pointed-step hulls but also would have very low hump

resistance. The results also indicated that the longitudinal stability of planing-tail hulls on the water would be less critical than that of conventional hulls, whereas the directional instability found in pointed-step models was eliminated.

Tests have been made in Langley tank no. 2 to determine the effects on resistance of varying a number of afterbody parameters of the planing-tail hull. The effect of varying length, width, and plan-form taper of the afterbody is given in the present paper. In the tests the depth of step and angle of afterbody keel were held constant.

#### COEFFICIENTS AND SYMBOLS

The data of the tests were reduced to the usual non-dimensional coefficients based on Froude's law. These coefficients are

$C_{\Delta}$  load coefficient  $\left(\frac{\Delta}{wb^3}\right)$

$C_V$  speed coefficient  $\left(\frac{V}{\sqrt{gb}}\right)$

$C_R$  resistance coefficient  $\left(\frac{R}{wb^3}\right)$

$C_M$  trimming-moment coefficient  $\left(\frac{M}{wb^4}\right)$

$C_d$  draft coefficient  $\left(\frac{d}{b}\right)$

where

$\Delta$  load on water, pounds

$V$  speed, feet per second

$R$  resistance, pounds

$M$  trimming moment, pound-feet

$d$  draft at step, feet

$w$  specific weight of water, pounds per cubic foot  
(63.0 lb/cu ft in these tests)

$g$  acceleration of gravity, feet per second per second

$b$  maximum beam of hull (1.08 ft)

#### DESCRIPTION OF MODELS

In order to avoid undesired effects of secondary variables not under study, the models were made with afterbodies of very simple form. Fillets and fairings were omitted; consequently the models would require further refinements before being made into hulls of good aerodynamic shape.

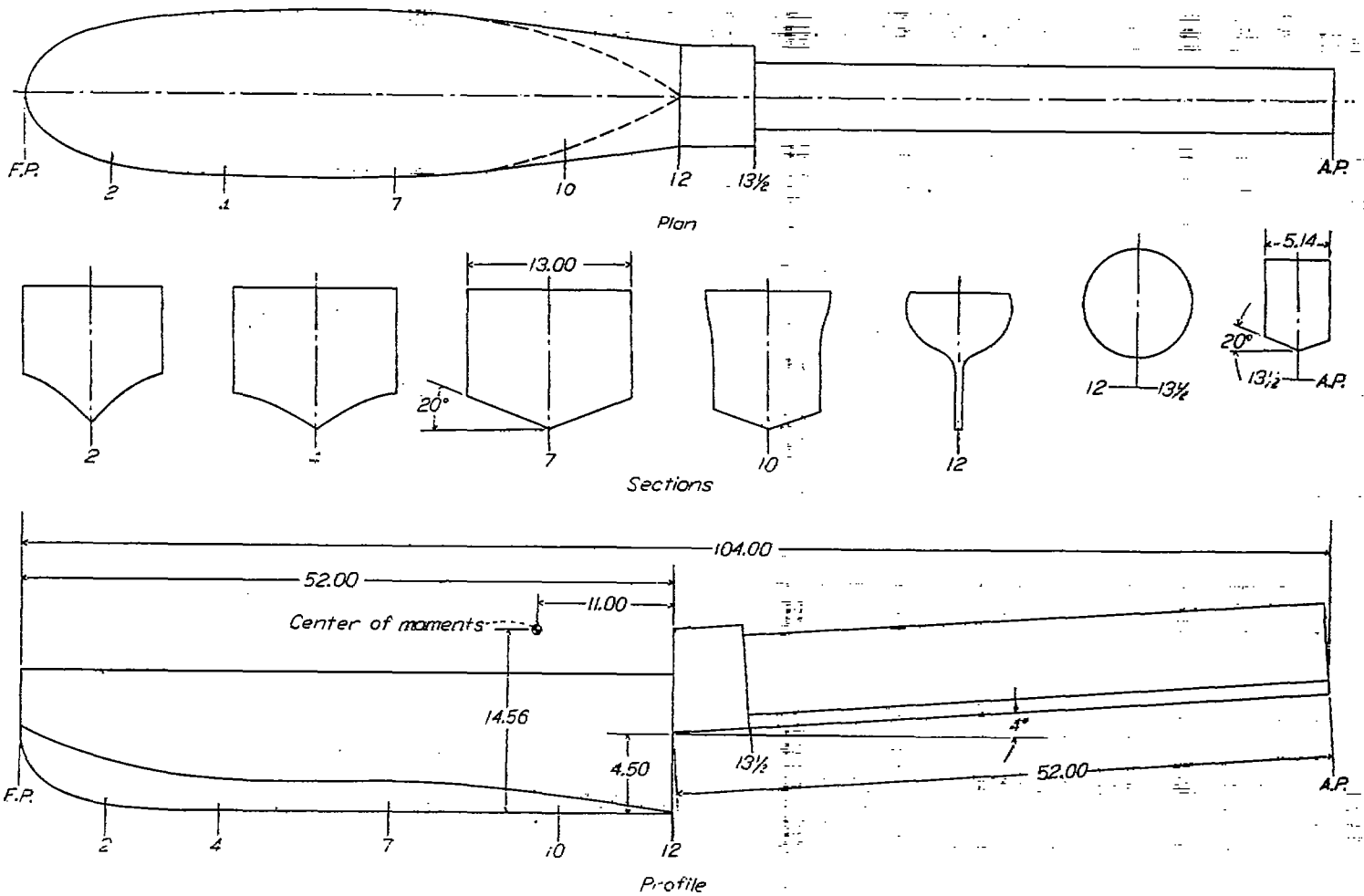

FIGURE 1.—Lines of Langley tank model 163A-11. (All dimensions are in inches.)

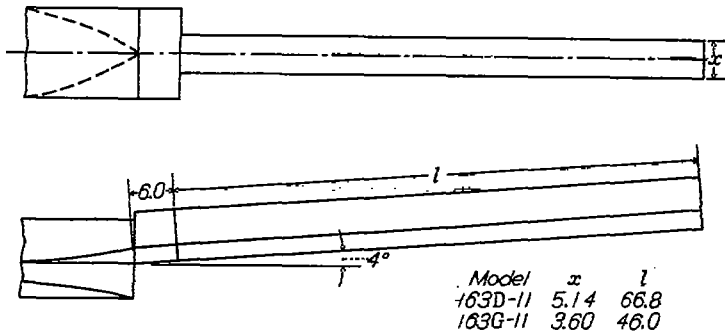

FIGURE 2.—Lines of rectangular afterbody. (All dimensions are in inches.)

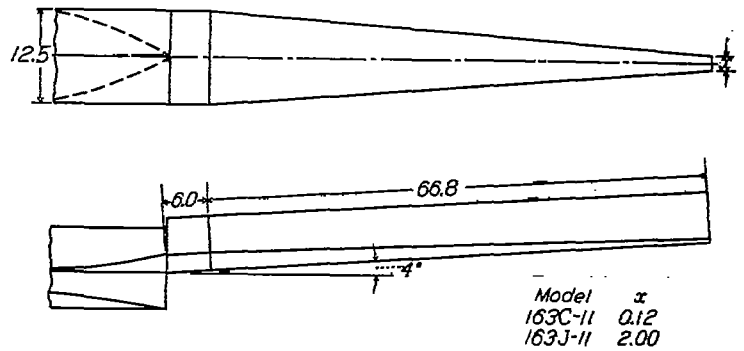

FIGURE 3.—Lines of tapered afterbody. (All dimensions are in inches.)

The lines of the models are given in figures 1 to 3. The forebody used in all models was the forebody of model 35-A, a pointed-step hull having an angle of dead rise of 20° and no chine flare (reference 3). This forebody was arranged so that various afterbodies could be attached; two types of attachment blocks were used for this purpose. (Compare figs. 1 and 2.) Both of these attachment blocks cleared the water below hump speed, and check tests made with one configuration showed that the effect of changing attachment blocks was negligible.

All models of the present tests had a depth of step of

4.50 inches and an angle of afterbody keel of 4°. The configurations that were tested are listed in the following table with the dimensions expressed in terms of the maximum beam;

Langley tank model	Length of afterbody (beams)	Width of afterbody (beams)	Plan form
163A-11	4.00	0.385	Rectangular
163G-11	4.00	.277	Do.
163D-11	5.60	.306	Do.
163C-11	5.60	.962 to .009	Straight taper
163J-11	5.60	.962 to .154	Do.

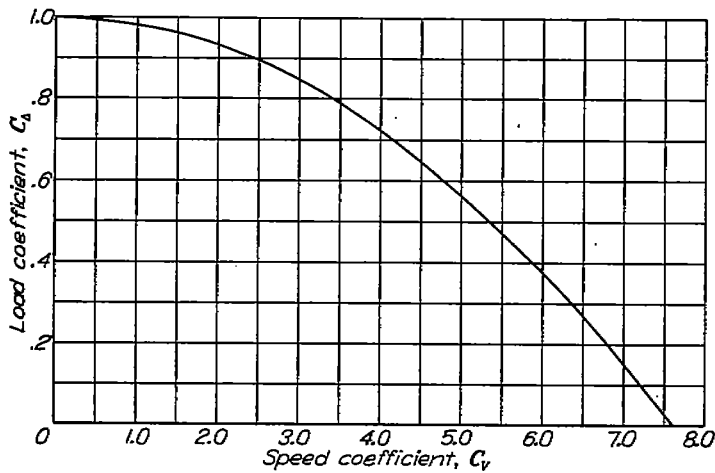

FIGURE 4.—Load curve based on constant lift coefficient.

TEST PROCEDURE

The tests were made by the specific method. The load on the model was applied by dead weights. In order to simplify the tests, wing lift was assumed to vary only as the square of the speed, and the parabolic load curve given in figure 4 was used in all tests. Fixed-trim runs were made at constant speeds, and resistance, draft, and trimming moments were measured for each run. A sufficient number of trims were investigated to give best trim, zero trimming moments for the center of moments used, and enough data for free-to-trim curves to be derived for a center-of-gravity location that would give best trim at the hump speed.

In order to obtain the resistance, the air drag of the towing gear was deducted from the measured resistance but the air drag of the model was not deducted. The plotted values of resistance, therefore, include the hydrodynamic resistance and the air drag of the model.

At high speeds and low trims the afterbodies of the models were clear of all water and spray. Under these conditions, the resistance of the complete model can differ from that of the forebody alone by only the small differences in air drag. Data from unpublished tests made with the forebody alone were compared with results from some of the present tests made with the complete configurations; under conditions in which the afterbodies of the complete models were clear of the water, the resistance was found to be negligibly affected by the presence of the afterbody. Data from the forebody tests were therefore used for some of the models in the speed regions where the afterbodies were clear, and only sufficient test runs were made with the complete model in this region to determine whether the afterbodies were definitely clear of the water.

The towing gear used in the present tests was of the same type as that used in the tests of reference 1. With this type of gear it was possible to observe whether any of the directional instability encountered with pointed-step models (reference 1) would be found with the planing-tail models.

RESULTS AND DISCUSSION

The fixed-trim data for all models are given in figures 5 to 9. These figures include curves of resistance, draft, and trimming-moment coefficients plotted against speed coefficient with trim as a parameter.

The only directional instability observed in the tests occurred for all the models at a trim of 4° between speed coefficients of 2.0 and 3.0. In this speed range a trim of 4° is too low to be of interest in a practical application and the curves of figures 5 to 9 show that the resistance is very much greater at a trim of 4° than at higher trims.

In order to show the effects of the several parameters under investigation (length, width, and plan-form taper of afterbody), both best-trim and free-to-trim (zero-trimming-moment) curves were derived for each model. (See figs. 10 to 13). Free-to-trim resistance characteristics are necessarily a function of the location of the center of gravity. In

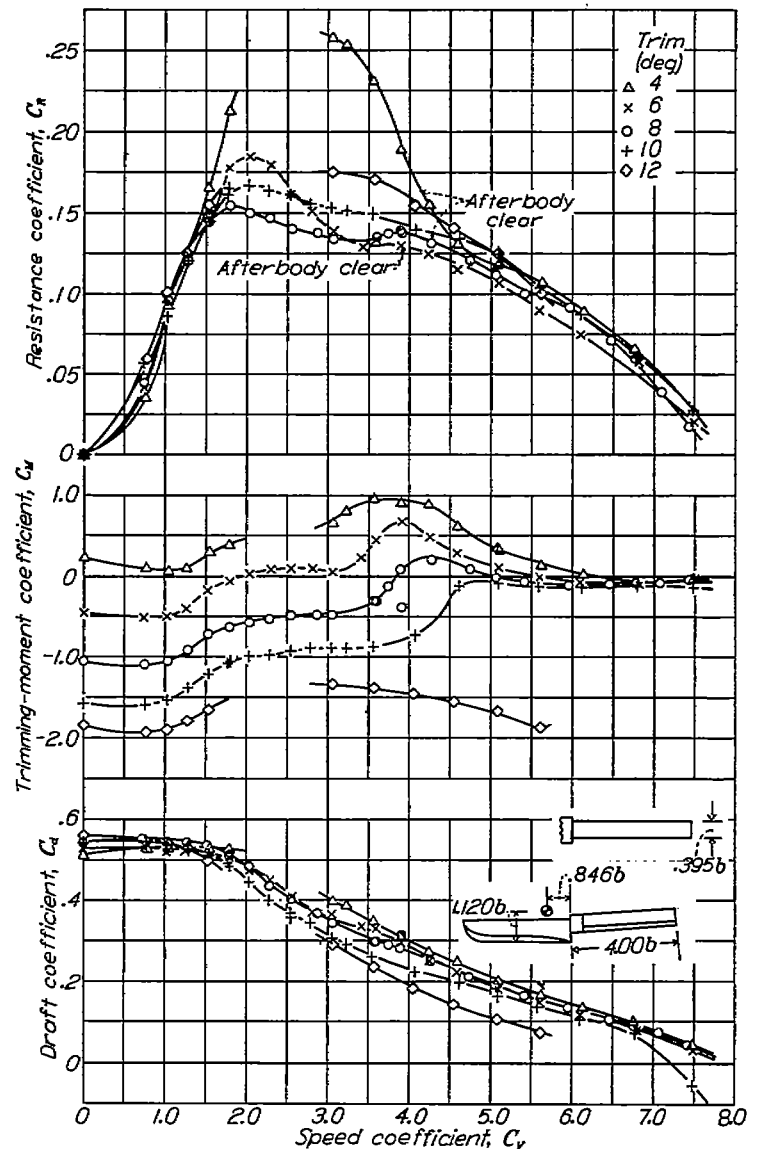

FIGURE 5.—Resistance, trimming-moment, and draft characteristics of model 163A-11 at fixed trim.

order to compare free-to-trim data of hulls of different forms, it is therefore necessary to establish a criterion for the selection of the centers of gravity at which the comparisons are to be made. The use of a location of the center of gravity that is a constant distance from some arbitrary point on the model, such as the step, does not always give a fair comparison because the optimum value for this distance may not be the same for each hull. The free-to-trim curves presented herein, therefore, were derived for a center-of-gravity location that would result in zero trimming moment for best trim at hump speed, and trimming-moment coefficients given for best trim were determined for the same center of gravity. The locations of the center of gravity that resulted from this procedure are shown in the sketches of figures 10 to 13.

EFFECT OF DECREASING WIDTH OF AFTERBODY

The effect of varying the width of the afterbody is presented in figures 10 and 11. A comparison of models 163A-11 and 163G-11 shows that decreasing the width of the afterbody from 0.395*b* to 0.277*b* increased the resistance at hump speed and had a negligible effect on the resistance

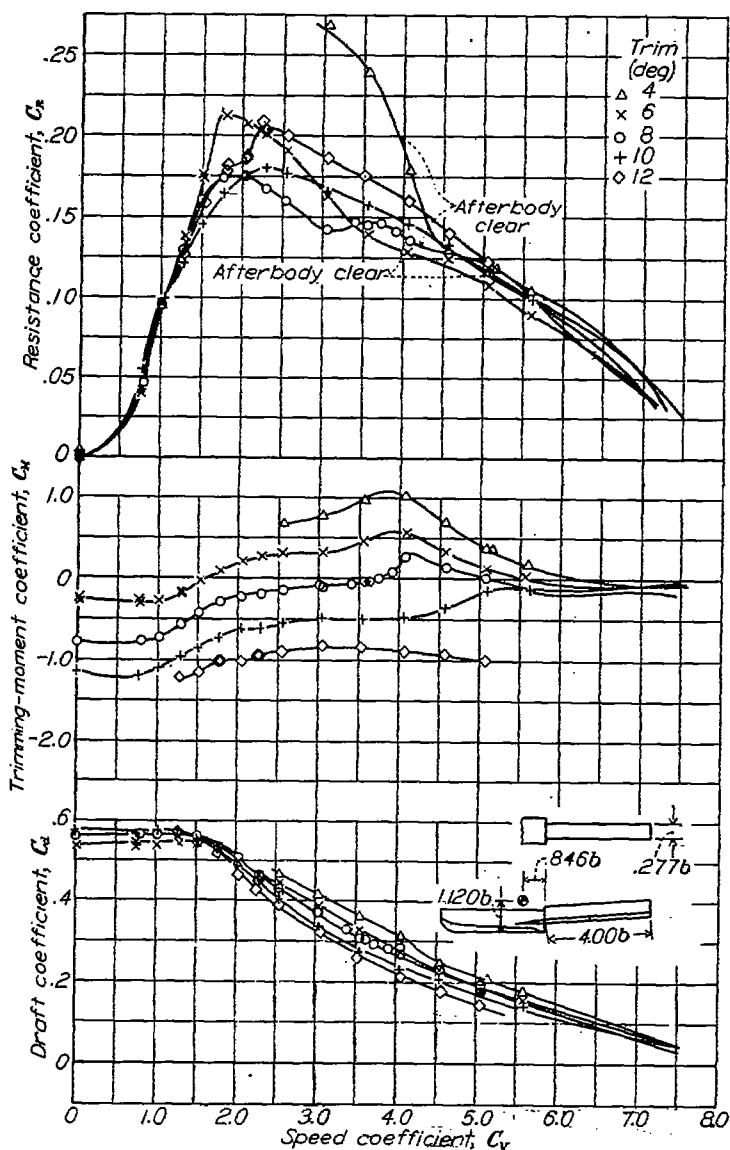

FIGURE 6.—Resistance, trimming-moment, and draft characteristics of model 163G-11 at fixed trim.

at high speeds. These effects were obtained in both the free-to-trim and best-trim conditions.

The magnitude of the trimming moments required to obtain best trim at high speeds was decreased by decreasing the width of the afterbody.

Decreasing the width of the afterbody had only negligible effects on best trim and on the trim for the free-to-trim condition. In fact, the differences in the free-to-trim curves were less than 1° throughout most of the speed range.

Decreasing the width of the afterbody moved forward the location of the center of gravity that gave best trim at the hump speed.

EFFECT OF INCREASING LENGTH OF AFTERBODY

Increasing the length of the afterbody from 4.00*b* to 5.60*b* (models 163A-11 and 163D-11 in figs. 10 and 11) decreased the resistance over nearly the whole speed range for both the best-trim and free-to-trim conditions. The differences between the curves of the free-to-trim and best-trim resistance were reduced by increasing the length of the afterbody.

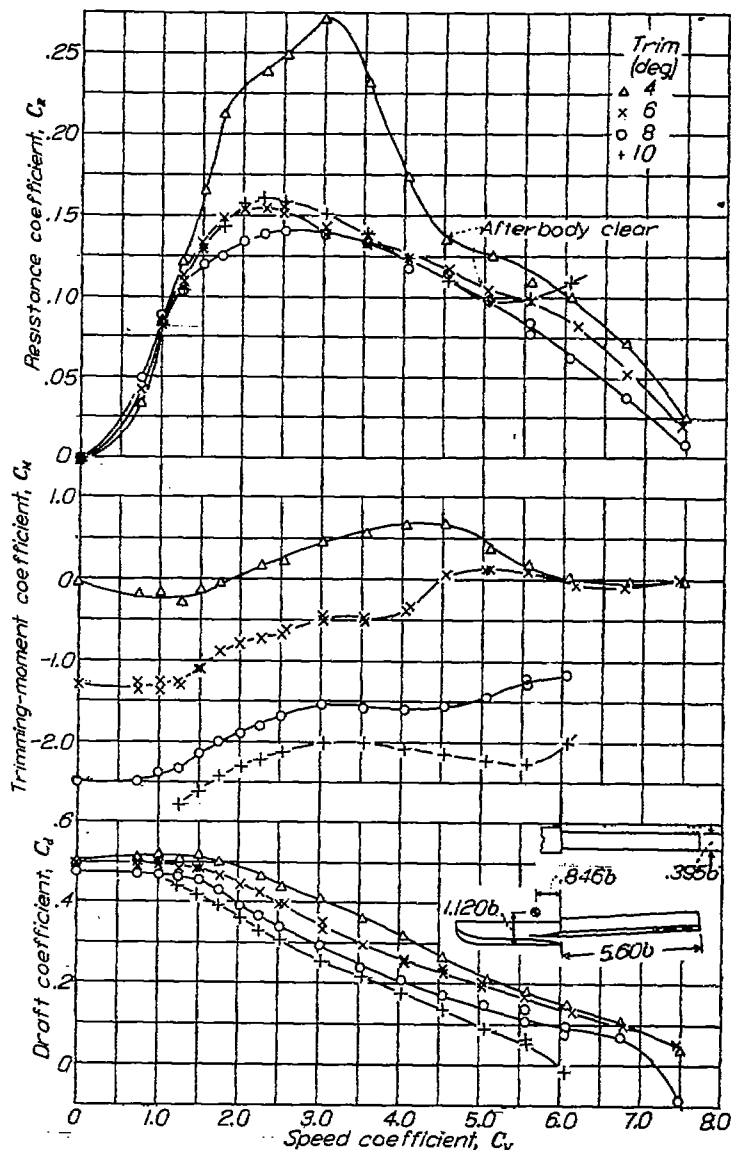

FIGURE 7.—Resistance, trimming-moment, and draft characteristics of model 163D-11 at fixed trim.

Over most of the speed range the free-to-trim resistance of the model with the long afterbody (model 163D-11, fig. 11) was actually less than the best-trim resistance of the model with the short afterbody (model 163A-11, fig. 10). Lengthening the afterbody reduced the resistance at hump speed to such an extent that the resistance curve is approximately parabolic in shape.

Increasing the length of the afterbody reduced the variation of trim with speed for both the best-trim and free-to-trim conditions. In the free-to-trim condition, the trim of model 163D-11 varied only  $1\frac{1}{2}^\circ$  throughout the whole speed range. Lengthening the afterbody, however, moved aft the center-of-gravity location for best trim at the hump speed; and the center of gravity to which these data apply is almost 1 beam aft of the step.

At both the best-trim and free-to-trim conditions the long afterbody of model 163D-11 was in the water at all speeds. At best trim, however, the afterbodies of models 163A-11 and 163G-11 cleared the water at a speed coefficient of approximately 4.0 and were not wetted at higher speeds; consequently, the complete models had almost the same resistance

as the forebody alone. The resistance at high speed of model 163D-11 with both the afterbody and the forebody planing was therefore less than the resistance at best trim of the forebody.

EFFECT OF TAPERING AFTERBODY

The effect of varying plan-form taper of the afterbody is shown in figures 12 and 13. The straight tapered afterbodies, models 163J-11 and 163C-11, had the same length as the long rectangular afterbody, model 163D-11, but the tapered afterbodies had considerably more area of bottom. (See figs. 2 and 3.) Both models 163J-11 and 163C-11 had less resistance over the lower half of the speed range than the model with the long rectangular afterbody and had approximately the same resistance at high speeds. The resistance curves for the tapered afterbodies are generally the same in shape as those for the long rectangular afterbody in that the peaks at the hump speeds have been eliminated so that the curves are approximately parabolic in shape. Variation in the amount of taper of the afterbody did not appreciably affect resistance.

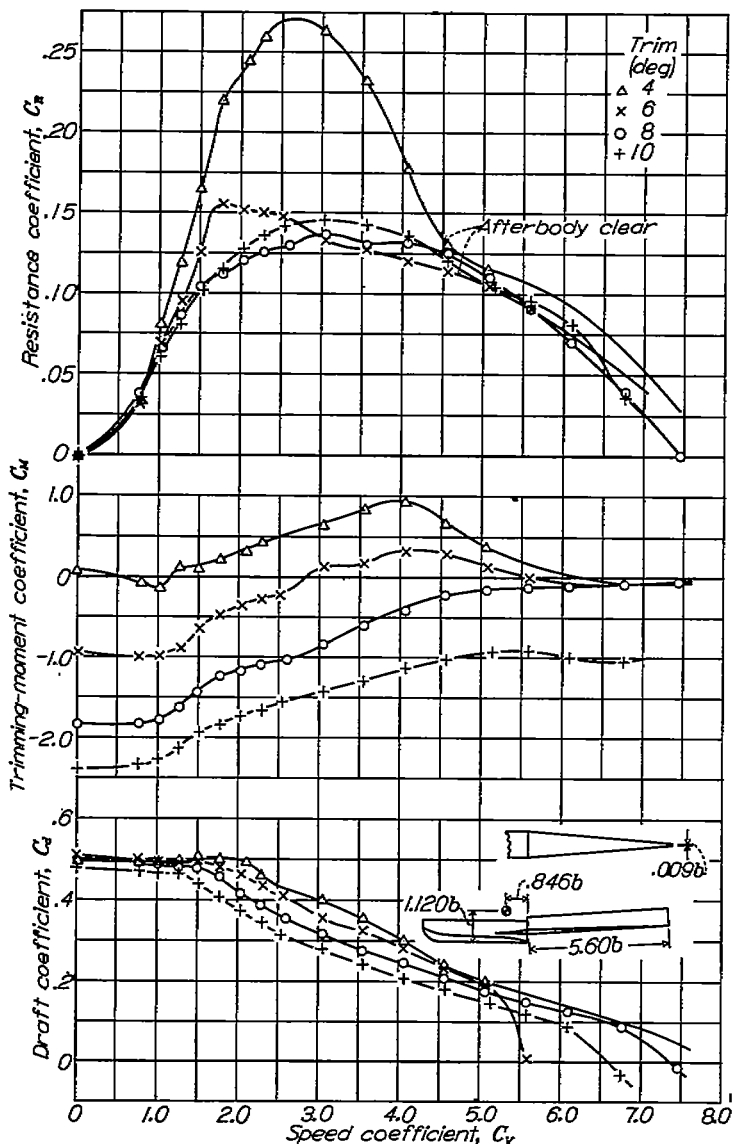

FIGURE 8.—Resistance, trimming-moment, and draft characteristics of model 163C-11 at fixed trim.

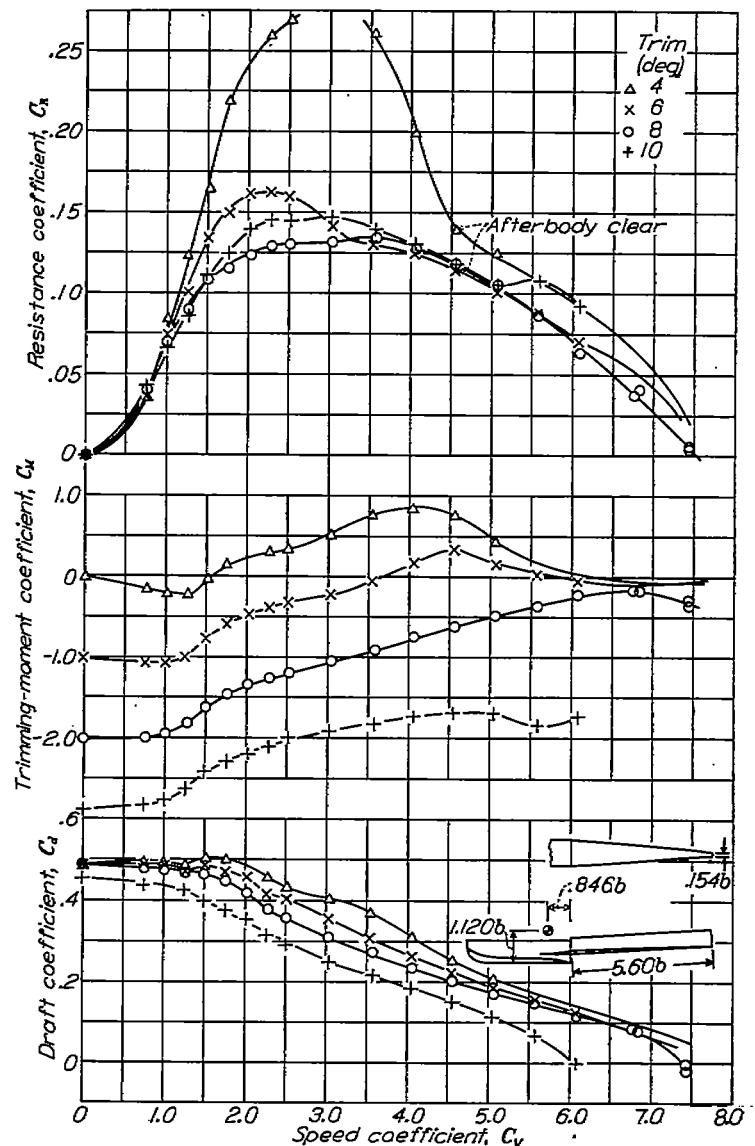

FIGURE 9.—Resistance, trimming-moment, and draft characteristics of model 163J-11 at fixed trim.

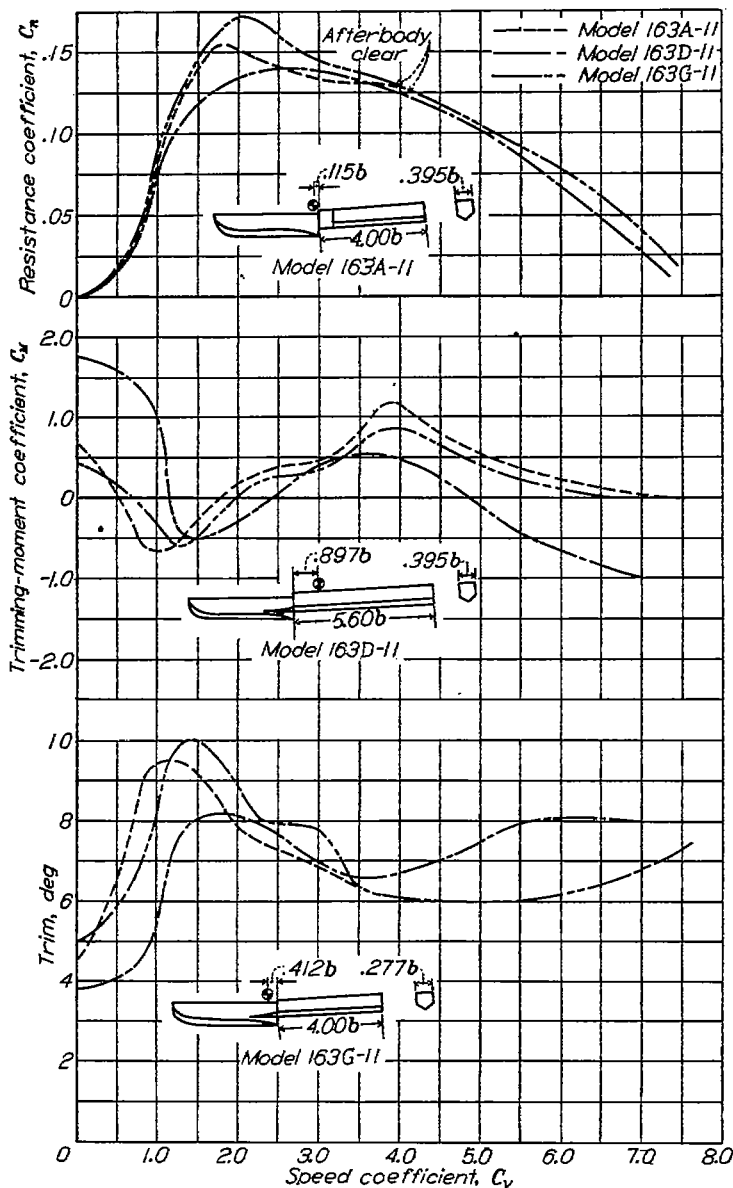

FIGURE 10.—Effect on best-trim characteristics of varying length and width of afterbody.

The locations of the center of gravity required for best trim at the hump were fairly far aft for the models with the tapered afterbodies, but increasing the taper moved this location forward.

#### COMPARISON OF PLANING-TAIL HULLS WITH A CONVENTIONAL HULL

The characteristics of one tapered-afterbody planing-tail model (model 163J-11) are compared with those of a representative conventional hull (designated hull A) in figure 14. In this figure, curves of resistance coefficient, trimming-moment coefficient, and trim are given at best trim for both hull A and model 163J-11 together with the free-to-trim resistance coefficient for model 163J-11.

The use of coefficients as given in figures 14 and 15 results in a comparison on the basis of equal beams for both hulls. When compared on this basis, model 163J-11 would be approximately 0.8 of a beam longer than hull A.

The best-trim resistance of the planing-tail hull was lower than that of the conventional hull throughout almost all the speed range. The critical regions for resistance are normally at the hump speed and near the get-away speed. In these

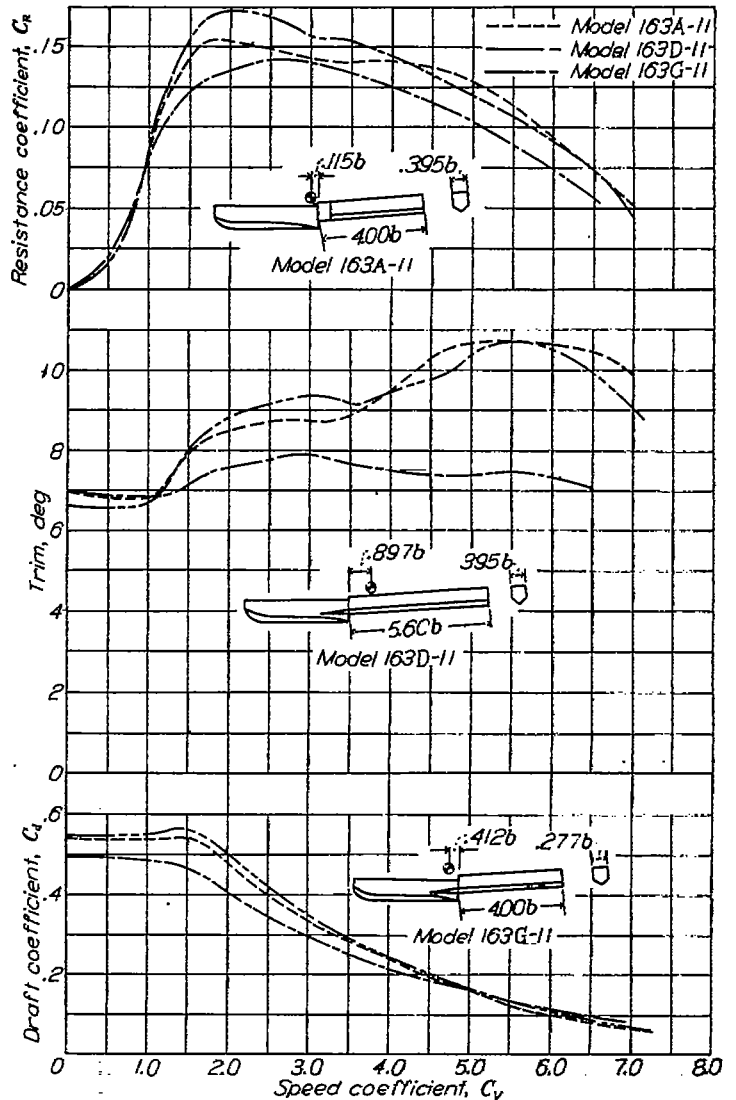

FIGURE 11.—Effect on free-to-trim characteristics of varying length and width of afterbody.

regions even the free-to-trim resistance of the planing-tail hull was noticeably lower than the best-trim resistance of the conventional hull. At the hump speed the resistance of hull A was 40 percent greater than that of the planing-tail hull, and near the get-away speed the resistance of hull A was from 75 to more than 100 percent greater.

At intermediate planing speeds in the region  $C_V=4.0$  to 5.5, the trimming moments required to obtain best trim were significantly higher for the planing-tail hull than for the conventional hull. In this region, however, the small differences between the curves of the free-to-trim and best-trim resistance showed that the resistance would be increased only slightly if aerodynamic moments available were inadequate to obtain best trim.

In the high-speed region the best trim of the planing-tail hull was higher than that of the conventional hull. In this region the best trim of the conventional hull was low because at higher trims spray from the forebody struck the afterbody and this "afterbody interference" tended to increase resistance. Because of the deep pointed step of the planing-tail hull, the spray from the forebody did not strike the afterbody; even in configurations in which the afterbody was of such length and width that it rode in the water at

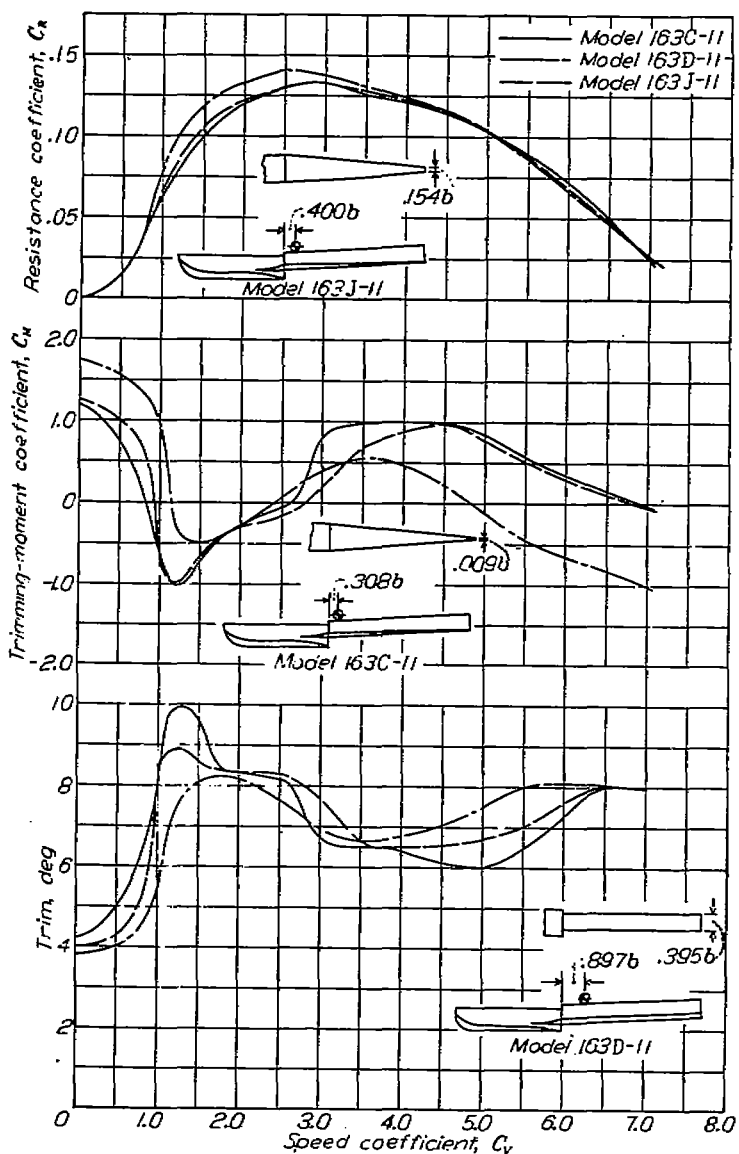

FIGURE 12.—Effect on best-trim characteristics of tapering afterbody.

high speeds (model 163D-11), the spray from the forebody still did not strike the afterbody in any appreciable quantity. At high speeds the best trim of the complete planing-tail hull was therefore approximately the same as that of the forebody alone. At speed coefficients greater than 3.0 the best trims for the planing-tail hulls tested were, in general, within 1° of those given in reference 4 for a simple planing surface with the same angle of dead rise (20°).

In figure 15 the ratio of load to resistance ( $\Delta/R$ ) at best trim is plotted against speed coefficient for all the models tested—also for hull A. Hull A had a value of  $\Delta/R$  at the hump speed of only 4.5, whereas the planing-tail hulls with tapered afterbodies had values of  $\Delta/R$  of about 6.5 at the same speed coefficient (2.6). At high speeds  $\Delta/R$  did not decrease so rapidly for the planing-tail models as for hull A. The value of  $\Delta/R$  for model 163J-11 at 90 percent of get-away speed was approximately 5.5, which is a value much greater than that usually obtained for conventional hulls at such a speed coefficient.

GENERAL REMARKS

Low resistance characteristics appear to be inherent in

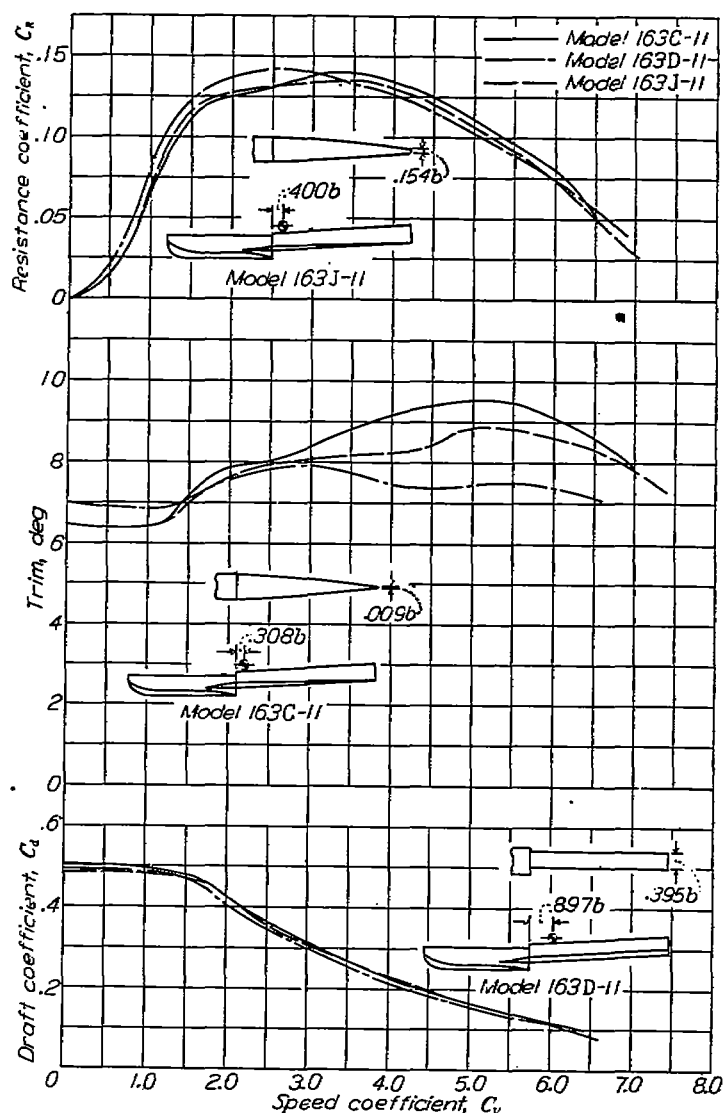

FIGURE 13.—Effect on free-to-trim characteristics of tapering afterbody.

the planing-tail type of hull. The low resistance at high speeds, which is characteristic of the pointed-step hull, has been retained in the planing-tail hull and, at the same time, the hump resistance has been decreased to a marked degree by an increase in the length of the afterbody. The trimming-moment characteristics of the configurations that give lowest resistance are such that the center of gravity would have to be located aft of the step in order to obtain best trim for a practical application. This location would tend to increase the length of the hull forward of the wing.

The models with tapered afterbodies, which have lower water resistance, would tend to have less air drag than the models with rectangular afterbodies.

The limited tests reported in reference 2 give the only data available on the longitudinal stability characteristics of planing-tail hulls. A comprehensive investigation of these characteristics would be desirable in order to obtain a more complete evaluation of the worth of this type of hull. An investigation of the effects on resistance of further variations in afterbody parameters would determine whether lower resistance curves than those of the present tests could be obtained.



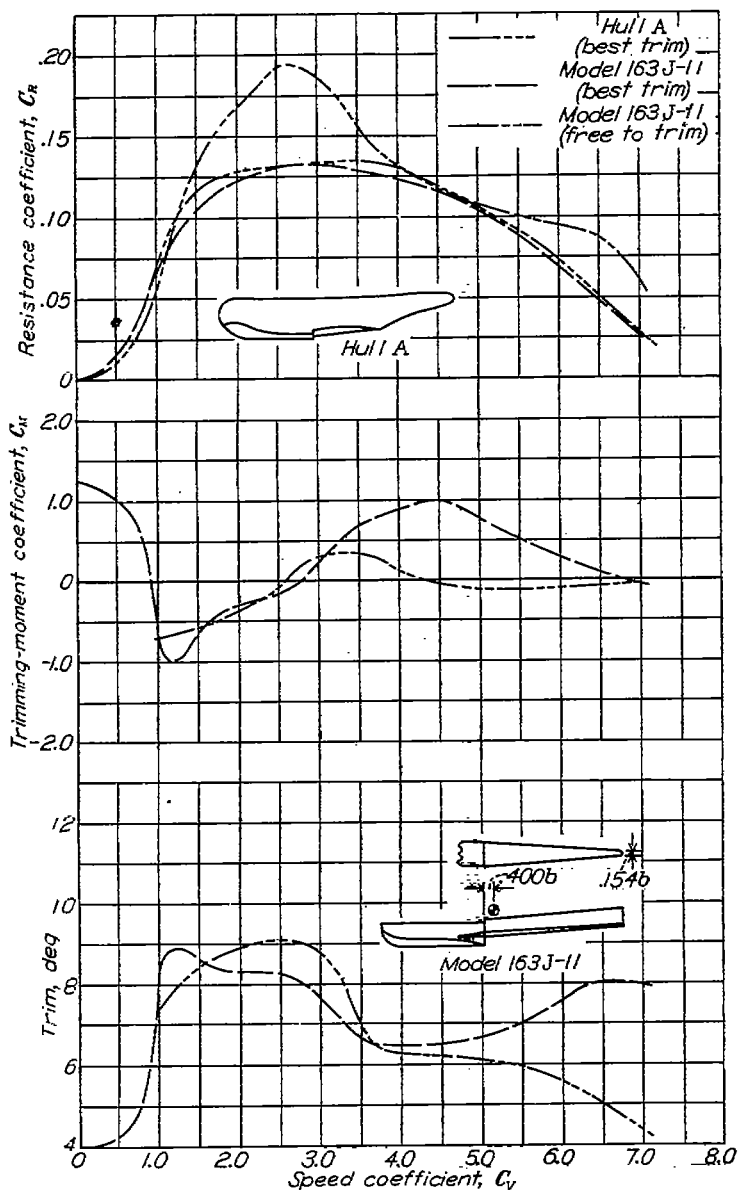

FIGURE 14.—Comparison of the resistance characteristics of a planing-tail hull with those of a conventional hull.

**CONCLUSIONS**

Results of tank tests to determine the effect of varying design parameters of planing-tail hulls led to the following conclusions:

1. Planing-tail hulls of the type tested had inherently much lower resistance than conventional hulls at both the hump-speed and high-speed parts of the take-off run. A typical conventional hull compared with a planing-tail hull had 50 percent greater resistance at the hump speed and from 75 percent to more than 100 percent greater resistance near the get-away speed; but in an actual application of the planing-tail hull, the center of gravity would have to be located aft of the step in order to obtain the reduction in resistance at hump speed.

2. Decreasing the width of the afterbody of a planing-tail hull increased the resistance at hump speed, decreased the trimming moment required to obtain best trim, and moved forward the location of the center of gravity required to obtain best trim at the hump speed.

3. Increasing the length of the afterbody of a planing-tail hull decreased the resistance over almost the whole speed

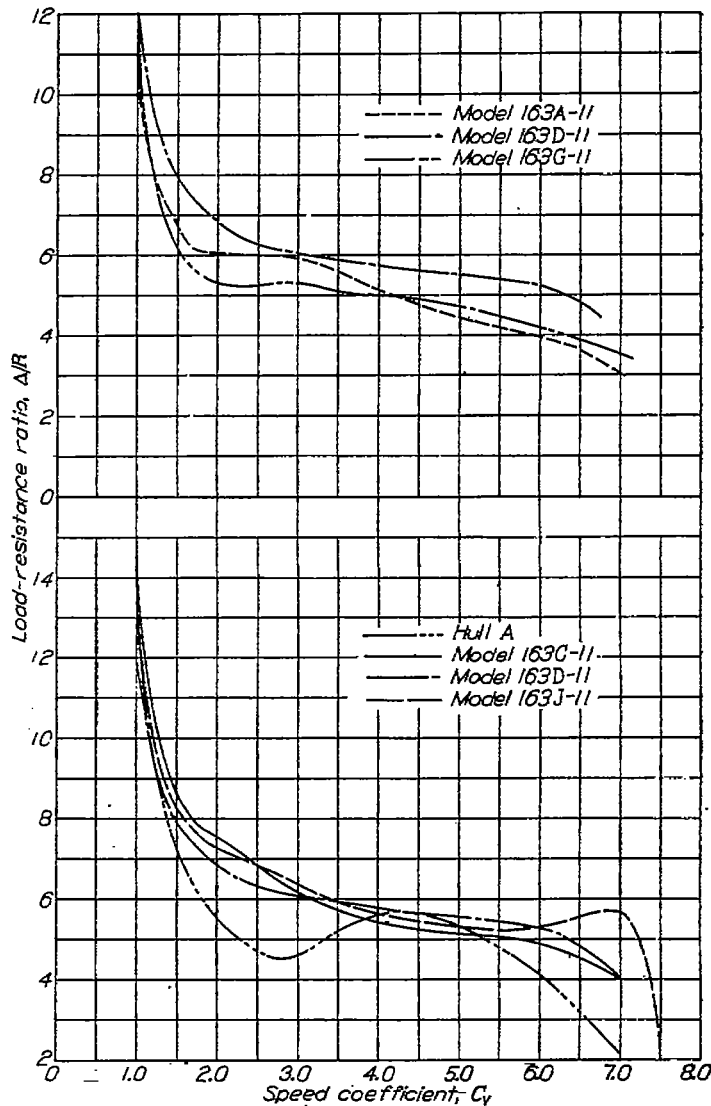

FIGURE 15.—Comparison of load-resistance ratios of planing-tail hulls and a conventional hull.

range, reduced the variation of trim with speed for both the best-trim and free-to-trim conditions, and moved aft the location of the center of gravity required to obtain zero trimming moment for best trim at the hump speed.

4. Tapering the plan form of the afterbody of a planing-tail hull reduced the resistance over the lower half of the speed range and had little effect on the resistance at high speeds. Plan-form taper also moved forward the location of the center of gravity required to obtain best trim at the hump speed.

LANGLEY MEMORIAL AERONAUTICAL LABORATORY,  
NATIONAL ADVISORY COMMITTEE FOR AERONAUTICS,  
LANGLEY FIELD, VA., January 7, 1946.

**REFERENCES**

1. Shoemaker, James M.: A Complete Tank Test of a Flying-Boat Hull with a Pointed Step—N.A.C.A. Model No. 22. NACA TN No. 488, 1934.
2. Dawson, John R., and Wadlin, Kenneth L.: Preliminary Tank Tests with Planing-Tail Seaplane Hulls. NACA ARR No. 3F15, 1943.
3. Dawson, John R.: Tank Tests of Three Models of Flying-Boat Hulls of the Pointed-Step Type with Different Angles of Dead Rise—N. A. C. A. Model 35 Series. NACA TN No. 551, 1936.
4. Shoemaker, James M.: Tank Tests of Flat and V-Bottom Planing Surfaces. NACA TN No. 509, 1934.