

REPORT No. 57

**THE SUBSIDIARY GAP AS A MEANS FOR IMPROVING
IGNITION**

**NATIONAL ADVISORY COMMITTEE
FOR AERONAUTICS**



PREPRINT FROM FIFTH ANNUAL REPORT

FILE COPY

To be returned to
the files of the Langley
Memorial Aeronautical
Laboratory

**WASHINGTON
GOVERNMENT PRINTING OFFICE**

1920

REPORT No. 57

**THE SUBSIDIARY GAP AS A MEANS FOR IMPROVING
IGNITION**



**NATIONAL ADVISORY COMMITTEE
FOR AERONAUTICS**



PREPRINT FROM FIFTH ANNUAL REPORT



**WASHINGTON
GOVERNMENT PRINTING OFFICE
1920**



REPORT No. 57

**THE SUBSIDIARY GAP AS A MEANS FOR IMPROVING
IGNITION**

BY

W. S. GORTON



REPORT No. 57.

THE SUBSIDIARY GAP AS A MEANS FOR IMPROVING IGNITION.¹

By W. S. GORTON.

RÉSUMÉ.

This report was prepared at the Bureau of Standards for the National Advisory Committee for Aeronautics.

Additional or subsidiary gaps have frequently been used in jump-spark ignition systems, in order to cause the resumption of sparking in fouled spark plugs. The series gap, to which the greater part of this report is devoted, is a subsidiary gap in the connection between the high tension terminal of the plug and that of the magneto or coil. A brief account is given of the use of this gap up to the present time and also of the statements concerning it which have gained some currency, most of which are shown to be erroneous. The simple theory of the action of the series gap is discussed and a detailed account given of the effect upon the sparking ability of the plug produced by changes in the values of the electrical resistance of the fouling and of the capacities in parallel with the plug and with the magneto or coil. Experiments confirm the main features of the simple theory. The points of difference between the conditions as postulated in the simple theory and the conditions actually existing are enumerated and their bearing upon the design and operation of the series gap discussed. The ensuing section is devoted to a discussion of the design of series gaps.

It is concluded that the series gap may be used as a remedy for a considerable part of the trouble due to the fouling of plugs which is met with in practice, since it has been found possible by the use of a series gap on an average ignition system to spark a plug having a fouling resistance of only 4,000 ohms.

INTRODUCTION.

The spark plugs used on internal combustion engines employing the jump-spark system of ignition are subject to many ills. At present the chief of these is the fouling of the plugs with carbon and oil, which are deposited on the surface of the insulation forming a conducting path between the electrodes of the plug. The resistance of this path frequently falls so low that sparks will no longer pass between the electrodes. It has been found that, under these conditions, modifications of the ignition system involving the use of an additional spark gap, or gaps, will cause sparks to pass again between the electrodes. Such spark gaps are called subsidiary gaps and the use of them will be discussed in this report.

Some of the ignition systems employing subsidiary gaps have been of designs radically different from those ordinarily used. In the majority of cases, however, the use of a subsidiary gap has involved merely the insertion of a gap in the connection between the high-tension terminal of the magneto or coil and that of the spark plug. Such a subsidiary gap is called a series gap, and it is with this gap as opposed to the other varieties of subsidiary gaps that this report principally deals.

The series gap has been made in many forms and employed in numerous ways. A large number of claims, frequently of an extravagant character, have been made in its favor, while there have also been objections raised against the use of such devices.

The purpose of this report is to make available, in a form convenient for reference, the more important information concerning series gaps, and to state what may reasonably be expected

¹ This Report was confidentially circulated during the war as Bureau of Standards Aeronautic Power Plants Report No. 31.

of them, in order to avoid either undue optimism or pessimism concerning their usefulness. To these ends the present report comprises:

- (A) A statement of the past and present state of "the art."
- (B) A summary of our present knowledge of the action of series gaps.
- (C) Design of the series gap.
- (D) An estimate of the degree of utility which may reasonably be expected of series gaps.

(A) PAST AND PRESENT STATE OF THE ART.

In the automobile field racing drivers have long used the series gap for improving the ignition of their cars. In its original form it consisted simply of a block of wood fastened to the spark plug. To this block was attached the high tension lead in such fashion that there was a small gap between the end of the wire and the terminal on the insulated electrode of the spark plug.

Recently various commercial forms of the series gap, usually intended for attachment to standard spark plugs, have appeared. Those of American manufacture that have come to the attention of this bureau are as follows: (a) Master, (b) Speco, (c) Superspark, (d) Walden Worcester.

The Master and Superspark devices may very well be described together as they are similar in construction. In each device the series gap is inclosed in a steel container which is intended to be air-tight. The spark takes place between steel points, one of which is integral with the steel housing.

The Speco device consists of a spark gap, the electrodes of which are of nickel alloy, which is open to the air. It is surrounded, however, by a Davy copper gauze to prevent the spark from igniting any gasoline vapor which may be present.

The Walden Worcester series gap is made integral with the spark plug of the same name. The electrodes are of nickel alloy and one of them is the central wire of the spark plug, the outer end of which is flush with the surface of the porcelain insulation. The gap is open to the air.

The French, in their aviation engines, have used a form of the series gap called by them the "Carbolyseur." It consists of a gap, at the central point of the distributor, the length of which can be varied at will by the pilot in order to secure the best running of his engine. No detailed description of the "Carbolyseur" is available at the present writing.

Several systems of ignition involving high frequency electrical oscillations have been devised. The Lodge system is the best known of these systems and will be described briefly. It consists simply of one or two condensers which are charged by the magneto or coil, and which discharge across a subsidiary gap, called by the inventor the "primary gap." The spark plug is included in the discharge circuit of the condensers and a spark takes place between the electrodes. The circumstances governing the passage of the spark are identical with those described later in the discussion of the action of the series gap.

Many advantages have been claimed for the series gap and some objections have been urged against it. The former are more numerous than the latter and some of them are so extreme in character that it was considered worth while to tabulate all of the claimed advantages and objections that have come to the attention of the bureau.

(a) Advantages claimed:

1. Ability to fire any plug no matter how badly damaged.
2. Increased power, speed, and economy.
3. Fatter, hotter spark.
4. Negligible energy lost in series gap.
5. Increases speed of propagation of explosion.
6. Visible spark gives means of finding trouble.
7. Leaner mixture may be used.
8. Reduces "amperage"; no burning out of breaker points.
9. Increased energy available for ignition.

(b) Objections urged:

1. Hard on insulation of ignition system.
2. Causes large drain of current.
3. Causes difficulty in starting.

The experimental and other evidence on the questions above enumerated will now be discussed.

(a) ADVANTAGES CLAIMED.

(1) Claim No. 1 is obviously not true. It is, of course, unquestioned that plugs can sometimes be fired by means of a series gap when they can not be fired without it, but the ability of the series gap to fire a fouled or otherwise damaged plug depends entirely upon the value of the resistance shunting the plug gap. If this shunting resistance reaches a sufficiently low value it may become impossible to fire the plug. For the average spark plug and magneto this limiting value of resistance is of the order of magnitude of several thousand ohms. Fouling with a resistance of this order of magnitude is of not infrequent occurrence.

(2) The use of a series gap may result in increased power, speed, and economy, as claimed, but, as far as our present knowledge goes, only indirectly. The increase in magnitude of the quantities named results solely from the fact that the use of the series gap may cause to be fired charges of the explosive mixture which otherwise would be discharged from the engine unignited. The claim of increased power, speed and economy as frequently made is that the use of the series gap will bring about the result mentioned even though every charge was being fired by the engine without the use of the gap. This claim has been investigated experimentally at the Bureau of Standards and found to be unjustified. Experiments were made on both a truck and an aviation engine in which a commercial form of the series gap was attached to each plug. A switch at each plug was provided, whereby the series gap could be short circuited at will. It was found that the running of the engine, and the consumption of gasoline, was entirely unaffected by the presence or absence of the series gaps through the wide range of mixtures, loads, and spark advance used. Experiments to determine whether the character of the spark discharge in the engine cylinder affected the running of the engine were also made. A condenser was connected through a switch to the terminals of a spark plug on one of the cylinders of an automobile engine. The condenser could be connected to or disconnected from the plug at will, thus modifying the character of the spark discharge in the engine cylinder markedly. No difference in the running of the engine could be detected whether the condenser was disconnected from the plug or connected to it. Additional experiments on this point, the results of which have come to the attention of this bureau, justify the conclusion that the character of the igniting discharge has no effect whatever on the running of the engine so long as the spark ignites the explosive mixture.

(3) The claim that the use of a series gap results in a "fatter," hotter spark is of minor importance, as it has by no means been shown that increasing the "fatness" of a spark increases its igniting power. Some experiments were made at this bureau with a plug artificially fouled and a series gap, which showed that whenever the spark passed its appearance was the same, whether there was a series gap present or not, or whether the plug was clean or fouled. The temperature of the spark is a very indefinite thing and little can now be asserted as to the magnitude of that quantity. The heat generated by the passage of the spark, however, can easily be measured. Investigations at the Bureau of Standards have shown that this last-mentioned quantity is in general reduced by the presence of the series gap. Whether or not this reduction in the total energy content of the spark involves a decrease in the igniting power of the spark is not now known.

(4) The ratio of the amounts of energy spent in the plug gap and series gap is equal to the ratio of the sustaining voltages of the respective gaps. The sustaining voltage of the series gap is of the same order of magnitude as that of the plug gap. Consequently the amount of energy lost in the series gap is not negligible.

(5) The experimental evidence obtained up to the present time shows that the character of the spark has no effect on the speed of propagation of the explosion. As mentioned above, experiments on an engine showed that the presence of neither the series gap nor a condenser

made the least difference in the power developed or speed attained. Consequently the effect, if any, of the presence of the series gap upon the speed of propagation of the explosion is too small to affect the power developed.

(6) It has been asserted by the proponents of the series gap that this device is in effect a "window in the cylinder" and that the passage of a spark in the series gap indicates infallibly the passage of a spark between the electrodes of the plug. This is not the case. Not infrequently plugs are so badly fouled that the breakdown of the series gap fails to fire them. Moreover, the passage of a spark across the series gap does not indicate thereby a healthy condition of the ignition system unless the series gap is set for a breakdown voltage equal to or greater than that of the plug.

(7) The use of a leaner mixture when the series gap is employed is due not to the series gap itself but to the fact that upon installing such devices a readjustment of the carburetor is generally made. Many owners of motor cars run with too rich a mixture, and a readjustment of the carburetor in accordance with the instructions of the manufacturer of the series gap results in a leaner mixture.

(8) Readings taken with a direct-current ammeter in series with a clean plug have shown that the presence of a series gap reduces the current as indicated by the instrument. The oscillograph, however, shows that the presence of the series gap has no effect other than to decrease the duration of the discharge between the electrodes of the plug. This is due to the higher sustaining voltage of the combination of plug and series gaps which causes the current in them to stop sooner than it otherwise would. The presence of the series gap does not affect the value of the current while it is flowing. Consequently it is readily seen that the indication of a direct-current ammeter in the circuit will be decreased by the presence of a series gap. This fact is probably the basis for the claim that the series gap reduces the "amperage."

Concerning the effect of the presence of series gaps upon the life of the breaker points little can now be said. The value of the current flowing through the breaker before the points open is probably in most cases not affected by the presence of the series gap. When it is affected, the effect is to increase the value of this current. This is due to the fact, mentioned in the previous paragraph, that when the series gap is used the current in the secondary of the magneto or coil dies out more rapidly than when no series gap is present. Consequently there is less chance of interference between the last part of one discharge and the beginning of the next, with a resulting decrease in the value of the primary current when the breaker opens. The previous sentence is applicable only to the magneto. In the case of the coil operated from a battery, interference rarely if ever takes place.

The above discussion applies to the case of a gap in series with a clean plug. If the gap is in series with a fouled plug, the comparison has to be made between the action of the fouled plug alone and the fouled plug in conjunction with the series gap. Oscillograms have been taken which show that the current in the primary at break, if no series gap is present, is in general the same whether the plug is clean or fouled. If there is any difference between the two cases it is that the primary current is greater when the plug is fouled. It was seen in the preceding paragraphs that the addition of a series gap increases the voltage across the breaker points and may sometimes increase the primary current at break. Consequently it would be expected that there would be a decrease in the life of the breaker points upon the addition of a series gap in circuit with a fouled plug. Experimental evidence on this point, however, is lacking at present.

(9) The use of a series gap may increase the amount of energy available for ignition only in the sense that it may cause a spark to pass between the electrodes of a plug when without it the spark would not pass. If the spark is going to pass at all, it will pass in such a short time after the opening of the breaker that a negligible amount of energy is lost in that time in the fouling. During the passage of the spark its resistance is small compared with that of the fouling, and consequently the fouling has little effect on the further course of the discharge. If the spark does not pass, the energy that would otherwise be expended in the spark is dissipated in the fouling.

(b) OBJECTIONS AGAINST THE USE OF SERIES GAPS.

(1) The series gap in an ignition system can not be set for a breakdown voltage less than that of the plug if the device is to be of any use. Consequently, the breakdown voltage of the combination of series and plug gaps will, in general, be greater than that of the plug gap alone. This state of affairs is not considered to be necessarily detrimental, as the insulation of the magneto or coil is supposed to be able to stand, for long periods of time, a potential equal to the breakdown potential of the safety gap. There is a possibility however, that the continued application of this higher potential may, in the end, weaken the insulation. Experimental evidence on this point is lacking at the present time.

(2) Experimental evidence on the claim that the use of a series gap causes a large "drain of current" has already been presented under section (a) 8 above. It was shown there that the series gap has but little effect on the currents in the various circuits.

(3) There is some evidence to show that the presence in an ignition system of a series gap, at least one of fixed length, may cause difficulty in starting the engine. A case was reported to this bureau in which a series gap of variable length was used on a truck engine. After the engine had run for a minute or so, it would continue to run satisfactorily over a wide range of settings of the series gap, from zero up to a maximum length; but, in starting, the series gap had to be entirely closed in order to get the engine to fire. In this case the plugs could not have been very dirty.

In experiments carried out at this bureau on a similar engine with artificially fouled plugs, it was found that the series gap had to be opened wide in order to start but had to be closed somewhat afterwards in order to fire steadily. The interpretation of the phenomena just described is not certain; but there can be no doubt that, in some cases, the presence of a series gap in the circuit is detrimental in starting. The conclusion is that series gaps should be made so that their length can be adjusted easily at any time during the running of the engine.

(B) OUR PRESENT KNOWLEDGE OF THE ACTION OF SERIES GAPS.**SIMPLE THEORY OF THE ACTION OF THE SERIES GAP, AND RESULTS OF EXPERIMENTS MADE TO TEST THE THEORY.**

NOTE.—Reference may be made to Report No. 58, Part I, for a more detailed discussion of the cycle of operations of a magneto or coil.

The outline of what takes place during the cycle of operations of a magneto or coil can be given in a few words and will be summarized in the following paragraphs.

The first of the periods into which the cycle of operations can be divided is that just before the opening of the breaker when the current in the primary is increasing due to the action of the electromotive force of the battery in the case of a coil, or that due to rotation in the case of a magneto.

The second of the periods is that in which the voltage builds up after the opening of the breaker. Before the breaker opens current is flowing in the coil. When the breaker opens the circuit this current decreases rapidly, in so doing charging the condenser and inducing an E. M. F. in the secondary. If the gap did not break down, this would go on until all the energy was electrostatic in form; but in general the gap breaks down before this stage is reached. Any arcing at the break lessens the rate of change of current, and so lessens the maximum voltage attained during this period.

When the discharge first begins to flow between the electrodes in the plug, it probably consists of a condenser discharge; that is, the capacity of the high tension winding discharges through the plug gap and the course of the discharge is much too fast for the ordinary oscillograph to record. This state, however, lasts only for a very short time, and then the discharge becomes a steady arc with approximately constant sustaining voltage. The effect of capacity in parallel with the plug, in particular the capacity of the leads and any apparatus connected to them, is to decrease the rate of rise of the E. M. F. and also the maximum value attained by it. If there are any dielectric losses in the insulating materials of the system, the same effect, that is, decreased rate of rise of the E. M. F. and smaller value of maximum voltage, will be produced.

The phenomenon described in the preceding paragraph applies to the case where the insulation resistance of the plug is high. If the plug is fouled, the insulation resistance is greatly decreased and the cycle of operations is somewhat different. The effect of this resistance shunting the plug gap is to decrease the value of the maximum voltage by diverting to the fouling energy which would otherwise go to charging the capacity in parallel with the plug. Another way of interpreting the phenomenon is that the fouling diverts to itself current that would otherwise charge the capacity in parallel with the plug and increase the voltage. The potential difference across the plug at any time must necessarily equal the ohmic drop in the fouling and can not be less than the breakdown voltage of the plug if the plug is to fire the charge. The problem then is to increase by suitable means the ohmic drop of the fouling.

The simplest means to secure the increased ohmic drop in the fouling is to insert an additional gap in the high tension circuit. If this be done, the equivalent simple circuits are as shown in figure 1. The plug gap and the series gap are labeled as such in the figure. R represents both the fouling and its resistance, while the three condensers shown in the figure

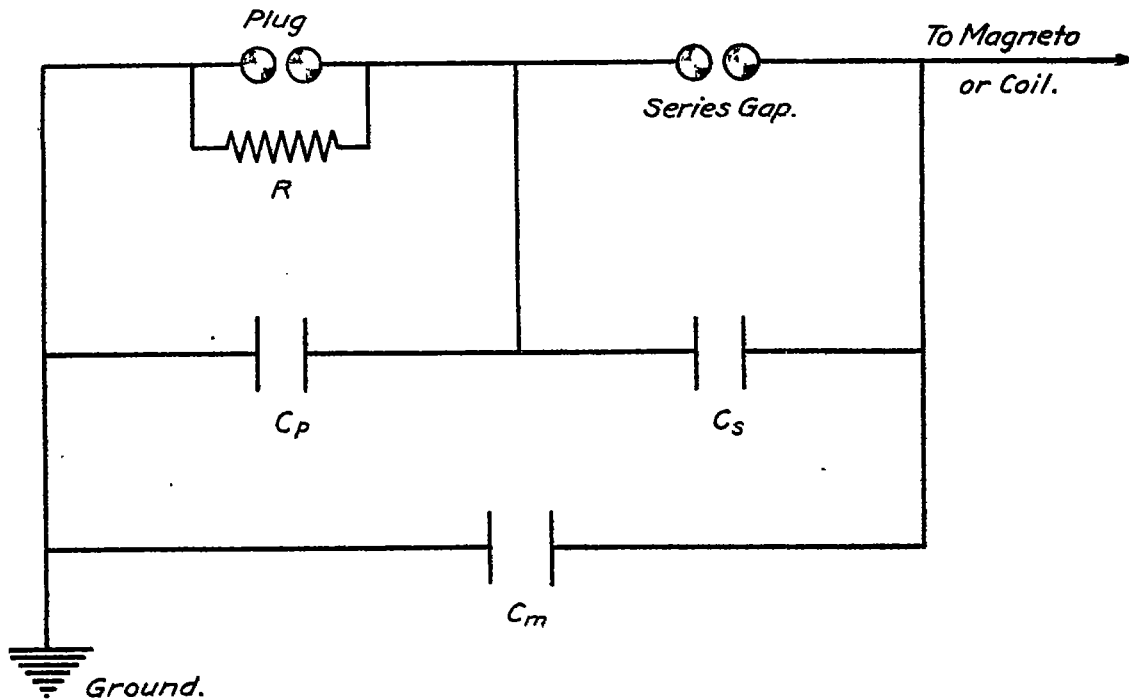

FIG. 1.

represent the distribution of capacity between the different parts of the apparatus. Let E_p and E_s represent the breakdown potentials of plug and series gaps, respectively, and e_m the voltage furnished by magneto or coil at time t . The mode of operation of the apparatus, neglecting the self-induction of the circuits and various other circumstances which need not be mentioned in detail here, is as follows:

The voltage furnished by magneto or coil, e_m increases after the opening of the breaker. During the increase, C_m is charged to potential e_m , as is likewise C_s , if R is small, say not greater than 100,000 ohms. When e_m reaches E_s , the series gap breaks down and a current flows to charge C_p . C_s discharges at the same time but this discharge has only a slight effect.

The potential to which C_p is raised by the discharge just mentioned is approximately

$$e_p = \frac{C_m \times E_s}{C_m + C_p} \quad (1)$$

If e_p is less than E_p , the plug can not fire. In any event a finite interval of time must elapse before the plug gap can break down during which time the potential of C_p is decreasing due to current flowing in R . If R is small, the plug gap may not break down at all, even though

e_p is greater than E_p . The effect of varying the different constants of the circuit is easily seen as follows:

A decrease in R obviously decreases the ability of the system to fire the plug due to the increased amount of charge which flows through the resistance and decreases the potential of C_p . To offset such an effect an increase in e_p is required. As can be readily seen by reference to equation (1), this can be brought about by an increase in C_m or E_s , or both. An increase in R causes the reverse effect. If R is large (of the order of 100 megohms) the condenser C_p is virtually insulated instead of being short circuited by R . Under these conditions, the voltage across C_p and C_s , before any spark passes, are respectively

$$\frac{C_s}{C_s + C_p} e_m = e_p \quad (2)$$

and

$$\frac{C_p}{C_s + C_p} e_m = e_s \quad (3)$$

Each of these voltages is smaller than e_m . Consequently, if a plug is clean, the applied voltage e_m required to spark the combination of plug and series gaps may be larger than if the plug is fouled, provided the resistance of the fouling is not too low.

It is seen from equation (1) that an increase in C_p causes a decrease in e_p ; consequently, it is in general advantageous to keep the capacity in parallel with the plug as small as possible. The one exception to this statement is for the case when the plug is clean. Under these conditions, it is seen from expression (3) that the voltage across the series gap increases with C_p , and therefore that the series gap will discharge more easily, the larger is C_p . An increase in C_p , however, makes the plug gap harder to fire, consequently C_p can not be increased beyond a certain limit without causing the plug to stop firing.

The capacity in parallel with the series gap has little effect on the operation of the system. During the discharge the presence of this capacity increases the current through the series gap. This increase in current causes an increase in the ionization in the series gap and consequently a slight decrease in the resistance of the series gap. If the plug is fouled, the capacity C_s is in parallel with C_m when the condensers are being charged and hence decreases slightly the maximum voltage furnished by the magneto or coil.

The effect of increasing C_m is seen from equation (1) to increase the voltage applied to the plug when the series gap breaks down. Consequently from this standpoint a large value of C_m is beneficial. However, increasing C_m decreases the maximum value of the potential furnished by the magneto, and so if C_m is increased too much the magneto will no longer be able to spark the plug gap.

Various experiments, made to test the above outlined theory of the action of the series gap, have come to the attention of this bureau. Some were made on plugs fouled by use in an engine and some on clean plugs shunted by a water resistance. Other experiments, instead of being carried out on a spark plug, were carried out on a gap consisting of a wire going through a hole in a plate. In all three cases, the subsidiary gap was a ball gap. The value of the shunting resistance in the last case was 10,000 ohms. The results of the experiments confirm the main features of the theory; that is, the change in the sparking ability of the system due to changes in the capacity and resistance of the various parts follows the requirements of the theory, with the exception of some anomalies which were ascribed to the oscillatory character of the discharge of the series gap. Evidence was also found that the actual fouling has a much lower resistance at high voltages than it has at low voltages, as though the conduction at high potentials were in the nature of arcs passing from particle to particle of the fouling. One of the most important conclusions reached was that the length of the series gap necessary to fire a fouled plug is extremely variable, and consequently any series gap used on an engine should be capable of easy adjustment while the engine is running.

The experimental evidence obtained at the Bureau of Standards, which need not be given in detail here, also confirms all the main features of the theory. One point worthy of note is that it was found possible to fire a plug in an engine when the resistance of the fouling, as measured by a megger, was as low as 4,000 ohms.

DIFFERENCE BETWEEN THEORY AND ACTUAL CONDITIONS IN THE OPERATION OF SERIES GAPS.

In discussions of the action of the series gap many conditions are frequently postulated for simplicity, either directly or by implication, which do not correspond to actual facts. These points of difference between the simple theory and actual conditions will be treated in detail in the following paragraphs as they must be considered in dealing with the question of series gaps.

The first point for discussion is the question of the potential given by a magneto or coil. It is generally asserted that this potential is seldom or never the same from one cycle of operations to the next. This statement has frequently come to the attention of this bureau. A justification given for this statement is that when a magneto or coil is sparking a gap, the maximum voltage as read by a crest voltmeter (a static voltmeter in series with a kenotron) is always varying; and also that at certain times the system is able to spark a longer gap than it is at others. These facts, however, could be just as well, or rather better, accounted for by a variation in the breakdown voltage of the gap instead of in the potential furnished by the magneto or coil. Experiments to test this point were made at the Bureau of Standards.

A magneto driven by belt from a motor was connected directly to a crest voltmeter, no spark gap except the safety spark gap of the magneto being in the circuit. At first it was run at approximately 300 revolutions per minute, the speed of the magneto at any instant being rather variable. The safety gap did not discharge at all. The voltage as read by the crest voltmeter was constant to within 1 per cent. The speed was then increased. As a consequence it was necessary to connect a condenser to the terminals of the magneto in order to prevent the safety gap from discharging. The voltage was even more constant than at the lower speeds; and, in fact, up to the highest speed employed in the experiment (1,600 revolutions per minute) the higher the speed the more constant the reading of the crest voltmeter. Conditions at speeds greater than 300 revolutions per minute, where a condenser had to be connected to the terminals of the magneto, are not quite comparable with conditions existing when the magneto is firing a gap; but at 300 revolutions per minute where no condenser was used they are directly comparable with the conditions of actual use. The experiment was tried of measuring the voltage with a crest voltmeter when the magneto was firing a gap at 300 revolutions per minute. The reading of the voltmeter was extremely variable. These facts show conclusively that any variation in the power of a magneto to spark a gap is due to variability in the gap rather than in the magneto.

The next point to be considered is the variability of sparking potential of the series gap due to one or more of the causes now to be discussed. It is a well-established fact that any change in the surface of the electrodes of a spark gap in general changes the sparking potential. In particular the long-continued passage of a discharge corrodes the surface, furnishing numerous points from which the discharge can pass, and increases the distance between the electrodes. These two varieties of change in surface conditions have opposite effects. The roughening of the surface makes the spark pass at a smaller value of the potential, and the increase in distance makes the spark pass at a higher potential. The total effect is probably first a slight decrease and then an increase in the sparking potential.

The temperature of the electrodes also has an effect on the breakdown voltage. If the electrodes are hot, the temperature of the gas between the electrodes is increased, and consequently the breakdown voltage of the gap is decreased if the gap is in communication with the atmosphere. If the gap is hermetically sealed, a variation in the temperature of the gas has no effect on the breakdown voltage. A further effect of an increase in the temperature of the electrodes is to change the nature of the surface films upon them. In general, an increase in temperature tends to dissipate the surface films, which have such a marked effect, usually inhibitory, on the passage of a discharge between the electrodes.

The medium in which the electrodes of the series gap are immersed is subject in general to changes in nature, pressure, and temperature. The only case in which a change in nature is to be expected is when the gap is tightly inclosed. Under these conditions the passage of a discharge causes chemical changes in the air, which have some effect, probably small, on the breakdown voltage. The changes in breakdown voltage due to changes in temperature and

pressure obey well-known laws, namely, the breakdown voltage is approximately proportional to the density and is only affected by temperature and pressure as they affect density.

The breakdown voltage of a series gap may be affected by the "hardness" of the gap. A gap is said to be hard when it has a higher breakdown voltage for rapidly varying potentials than it has for slowly varying potentials. Hardness is of two kinds. If the electrodes are pointed, the gap is hard, due to its own form. For a rapidly varying potential, that is, one that rises quickly to a maximum and then decreases to approximately zero in a very short time (in other words, such a wave of potential as a magneto gives), the potential across a gap with pointed electrodes frequently rises to as much as twice or three times the normal breakdown voltage without a spark passing. Obviously, then, pointed electrodes are not suitable for use either for plug or series gaps.

For electrodes that are not pointed, that is, ones not having a radius of curvature small compared with their distance apart, hardness of the kind above described does not exist. Electrodes of this kind may be subject to a hardness due to some condition of the surface such that the breakdown voltage for a rapidly varying potential is somewhat larger than that for a slowly varying potential but rarely more than 1.5 times as great. The condition of the surface which produces such hardness is not well understood. It is known, however, that films of oil are capable of producing it. Consequently, in designing gaps, allowance has to be made for times when the breakdown voltage is abnormally large.

The effects of previous discharges across a gap are to modify the hardness, as described in the immediately preceding paragraph, and to cause a greater number of ions than normal to be present in the gap. The hardness of the gap is as likely to be increased as it is to be decreased. The presence of an abnormally large number of ions in the gap has no effect upon the breakdown voltage of the gap but does cause the discharge to pass more promptly than it otherwise would.

Change in dimensions due to temperature changes may occur in the series gap. The principal danger is not due to isotropic expansion but to warping owing to a strained condition of the structure of the gap.

Series gaps have not been used extensively enough to permit the accumulation of any data as to the importance in practice, relative or absolute, of the different effects named above.

The plug gap is affected by all the conditions that have just been enumerated. The different circumstances in the engine cylinder, however, modify the relative importance of these conditions.

The plug gap is subject to much more corrosion than is the series gap on account of the much higher temperatures prevailing in the engine cylinder, which are so high that surface films are probably prevented from forming.

Variation in the proportions of the mixture probably has little effect on the breakdown voltage. Variation in the compression has considerable effect, the breakdown voltage being proportional to the density of the charge at the moment of firing.

The presence of oil in the gap generally increases the breakdown voltage because the discharge is obliged to follow a much longer path through the gas than if the oil were not present. It is possible, if there is not much oil in the gap, that the breakdown voltage may be decreased because it is well known that sparks will pass over considerably greater distances along the surface of insulators than they will directly through the gaps. It is generally thought, however, that this condition is seldom realized. The presence of carbon on the electrodes decreases the breakdown voltage. Not infrequently the carbon forms a bridge from one electrode to the other and effectually short circuits the plug.

The higher temperatures prevailing in the engine cylinder render any change in the dimensions of the gap, due to temperature, more important than is the case in the series gap; but with a proper design of plug, this effect is not to be feared.

In view of the high temperatures existing in the engine cylinder, it is thought that plug gaps never exhibit the phenomenon of hardness. This opinion is particularly important for the problem of the series gap because when the series gap breaks down the voltage on the plug gap increases at a rate thousands or millions of times greater than the rate at which potential

is applied to the series gap. Any hardness found in the plug gap will probably cause much greater variations in the breakdown voltage of the plug than will the same amount of hardness in the breakdown voltage of the series gap.

A further point of difference between the simple theory of the action of the series gap and actual conditions with a fouled plug is found in the fact that the resistance of the fouling decreases as the E. M. F. applied to it increases. The evidence on this point has been already given. It is easily seen that this characteristic of the fouling requires a larger increase in the breakdown voltage of the series gap for a given increase in breakdown voltage of the spark plug gap than if the resistance of the fouling were constant.

It was seen that an improvement in the action of the series gap could be secured by putting a condenser of suitable capacity in parallel with the source of E. M. F. This condenser should have as small dielectric losses as possible, as the maximum E. M. F. of the magneto or coil is decreased by an amount which depends directly upon the magnitude of the losses.

In discussions concerning the action of the series gap, it is practically always assumed that the passage of a discharge between the terminals of the plug will always fire the charge, and consequently, that the problem is solved when the plug can be made to pass a spark at the proper time in every cycle of the engine. That this assumption is not always true, is shown by the circumstances reported to this bureau and mentioned above, that a certain engine would not start with the series gap in circuit but would run with the gap in circuit after being started. Some experiments at the Bureau of Standards made, it is true, with a smaller gap than is usual in plugs (0.15 to 0.30 mm.) gave the following results: A gap was inserted in series with a clean plug in one of the cylinders of a four-cylinder engine. When the length of the series gap was zero the cylinder would miss steadily. As the length of the series gap increased the missing became less, and at a certain value of the gap the engine fired perfectly. As the length of the series gap was still further increased, the cylinder fired perfectly for a short range. As the gap was increased still further, however, missing began again, and for a still further increase in length the cylinder missed all the time. At all times during the experiment the series gap would pass a discharge at the proper instant of each cycle. When the cylinder was firing perfectly, obviously a discharge must have been passing between the electrodes of the plug. When the length of the series gap was increased and a discharge still kept passing in it, the plug in the engine cylinder must have given a spark for each discharge of the series gap. This fact shows that a spark between the terminals of a plug does not necessarily fire the charge in the engine cylinder, even though there is no change in the composition or density of the charge. It is not known whether any phenomena similar to those just described take place for spark-plug gaps of the dimensions generally used (0.50 mm.), but it will be well in any discussion of the action of series gaps to bear in mind the possibility of their occurrence.

(C) THE DESIGN OF THE SERIES GAP.—FORM AND MATERIALS OF ELECTRODES.

GENERAL DESIGN.

The following requirements must be satisfied by a series gap if it is to be of practical use. Its breakdown voltage must be reasonably constant and greater than that of the plug; it must be able to spark the plug for the lowest value of fouling resistance likely to be met with in practice; and it must be reliable in action and of reasonably long life. In the following paragraphs will be pointed out the way in which the above requirements affect the design of the gap.

FORM AND MATERIAL OF ELECTRODES.

The first question to be decided is that of the form and material of the electrodes, as these are by far the most important factors in determining the breakdown voltage of the gap. In this connection it has been suggested that a multiple gap could be used instead of a single gap. There is at present practically no evidence that a multiple gap would offer any advantages over a single gap. As to the shape of the electrodes, it was seen above that pointed electrodes are entirely unsuited for use either in the series gap or in the plug gap, and that in order to avoid hardness the radius of curvature of the electrodes should not be small compared with the dis-

tance between electrodes. As long as this condition is satisfied the precise shape of the electrodes seems to make no difference.

The requirements that the material of the electrodes should satisfy are as follows: The breakdown voltage should be constant; the material should have good mechanical properties, high thermal conductivity to prevent heating, and should corrode but little in order that the gap should have a long life. Nickel alloy wire of the sort used in spark plugs would seem to satisfy these requirements best at the present time.

INSULATION OF GAP.

The insulating material supporting the electrodes of the series gap should have, first and foremost, a very high insulation resistance. This is absolutely necessary because any leakage between the electrodes of the gap is fatal to the gap's functioning. This material should be able to stand heat without impairing its insulating properties, if the gap is integral with the plug; and if the gap is tightly inclosed should be able to withstand corrosion by the nitric acid which is formed from the air by the passage of the spark.

HOUSING OF THE GAP.

The series gap may be either in communication, more or less direct, with the atmosphere, or may be tightly inclosed, even hermetically sealed. If the gap is open to the atmosphere, there is little opportunity for corrosion by the discharge, and the consequent probable impairment of the insulating properties of the housing. However, there is a certain fire risk if any considerable amount of gasoline vapor should be in the vicinity of the gap. Tests at the Bureau of Standards have shown that this fire risk may be eliminated by the use of a Davy gauze inclosing the gap. A further point to be considered in connection with a gap open to the atmosphere, when used on an aviation engine, is that at high altitudes the breakdown potential of the gap is decreased. However, the density of the charge in the engine cylinder is correspondingly decreased, and the result is to preserve unchanged the ratio of the breakdown voltage of the series gap to that of the plug gap. If the gap is hermetically sealed, the products of discharge can not escape, and there is a chance that the insulation resistance of the housing may be decreased. Nothing is known at present about the amount of the products of discharge and their effect upon the insulation resistance of the housing. A tightly inclosed gap gives rise to no fire risk and has a constant breakdown voltage irrespective of altitude. As the breakdown voltage of the plug in the engine cylinder decreases with increase in altitude, it is seen that a tightly inclosed gap offers great advantages in the matter of firing fouled plugs at high altitudes. The adjustment of the length of a tightly inclosed gap, however, demands some attention. The present state of our knowledge of the subject points to the necessity of the pilot being able to adjust conveniently and at any time the length of the series gap. To satisfy this requirement in a tightly inclosed gap is not impossible, but evidently complicates the design and manufacture of the gap considerably.

LOCATION OF THE GAP.

The series gap has been placed in several locations: Integral with the plug; at the plug, but not integral with it; and at the center of the distributor. These various positions have their advantages and disadvantages. If the gap is integral with the plug, it is in the best position electrically, because the capacity of the leads is directly in parallel with the magneto. However, if the gap is integral with the plug, it can not be adjusted while the engine is running without the addition of an undesirable amount of mechanism. Also the series gap in this place will get hot, and its breakdown voltage will be subject to considerable variations. If the gap is at the plug but not integral with it, it is still in the best place electrically, will not get so hot, and will not be so subject to variations in its breakdown voltage. It can not be adjusted, however, while the engine is running without additional mechanism. If the gap is at the distributor, it is not in such a good place electrically for firing a fouled plug. The capacity of the leads to the plug is in this case directly in parallel with the plug and consequently has a detrimental

effect on the ability of the series gap to fire the plug. There is only one case in which this position of the capacity may be advantageous. It was previously shown that for a clean plug it is partially advantageous to have the capacity in parallel with the plug. A further advantage of having the gap at the distributor is that its length can be adjusted easily while the engine is running. As was seen from the data given above, a gap of fixed length does not seem to be at all suited for the function of firing a fouled plug, and consequently, in order to be of any considerable amount of use, the gap should be capable of adjustment while the engine is running. It is possible, however, that one adjustable gap at the center of the distributor which serves all the plugs may not be a good arrangement, for some of the plugs may be clean and some may be fouled, the clean plugs requiring a different length of gap for their effective firing than the fouled plugs. This suggests the possibility of having a gap in series with the lead to each plug and close to the distributor. This would call for a separate adjustment of the length of each gap. Whether the additional amount of apparatus thus required and the additional amount of attention required from the pilot (in the case of an airplane engine) would be justified by the results obtained is a matter for practical test.

(C) DEGREE OF UTILITY TO BE EXPECTED OF SERIES GAPS.

As a result of the evidence given above, it may be concluded that the modification of jump-spark ignition systems by the addition of a properly designed and operated gap in series with each plug may remedy effectively a considerable part of the trouble due to cases of fouling met in practice. At present the limits of the method are not known; that is, one can not say definitely just what is the lowest fouling resistance which can be handled by a series gap on a given ignition system and, conversely, whether a given ignition system can or can not, by the use of a suitable series gap, be made to spark a plug with given fouling resistance. The possibilities of the device, however, are well shown by the fact, mentioned before in this report, that it was found possible in one case by using a series gap on an average ignition system (magneto) to spark a plug having the extremely low value of fouling resistance of 4,000 ohms. The only other positive conclusion that can be stated now is that the length of the series gap should be capable of easy adjustment by the operator of the engine at any given time.

In addition to work done in the laboratory and on a few engines, the installation of a large number of gaps in practice and a careful record of their performance is necessary before the question of the practical utility of the series gap can be considered as entirely settled. This practical test can be carried out at any time and independently of laboratory work, and its results would be of the greatest value.