

To ~~Shawell Ober~~
from
~~Edward P. Warner~~
W. T. Del.

AER. & AS. RO. LIBRARY
JUN 8 1967
M. I. T.

REPORT No. 72

c. 3

WIND TUNNEL BALANCES



NATIONAL ADVISORY COMMITTEE
FOR AERONAUTICS



PREPRINT FROM FIFTH ANNUAL REPORT



WASHINGTON
GOVERNMENT PRINTING OFFICE
1920

REPORT No. 72

WIND TUNNEL BALANCES



**NATIONAL ADVISORY COMMITTEE
FOR AERONAUTICS**



PREPRINT FROM FIFTH ANNUAL REPORT



**WASHINGTON
GOVERNMENT PRINTING OFFICE
1920**

REPORT No. 72

WIND TUNNEL BALANCES

NATIONAL ADVISORY COMMITTEE
FOR AERONAUTICS



REPRINT FROM FIFTH ANNUAL REPORT

WASHINGTON
GOVERNMENT PRINTING OFFICE
1918

REPORT No. 72

WIND TUNNEL BALANCES

BY

EDWARD P. WARNER and F. H. NORTON
Aerodynamical Laboratory, National Advisory Committee
for Aeronautics, Langley Field, Va.

REPORT No. 75

WIND TUNNEL BALANCES

EDWARD P. WARRNER and F. H. ZORTZ

Aerodynamical Laboratory, National Advisory Committee
for Aeronautics, Langley Field, Va.

REPORT No. 72.

PART 1.

WIND TUNNEL BALANCES.

By EDWARD P. WARNER AND F. H. NORTON.

DESCRIPTION AND DISCUSSION OF THE BALANCE FOR THE ADVISORY COMMITTEE'S WIND TUNNEL AT LANGLEY FIELD.

In designing a balance for the Langley Field wind tunnel, after careful consideration and analysis of the various types which have been used at other laboratories, as well as of several arrangements not hitherto tried which were suggested, it was decided to adhere in general to the type of balance which has been used, substantially without change, for a number of years by the National Physical Laboratory. There is no other so simple to use, yet the accuracy attainable is as great as with any of the more complicated types. The design was modified in some respects to permit of the measurement of larger forces than those for which the original N. P. L. balances are suited, as well as to introduce certain changes which seemed likely to improve the convenience or accuracy of the work. In the description which follows particular attention will be paid to the details in which the balance differs from its prototype, very full descriptions of the latter having been printed in many places.¹ For the benefit of those who are not familiar with the N. P. L. balance it may be briefly explained that its distinguishing feature is the carrying of the whole balance on a single pivot, thus permitting it to rock in two planes. The model is mounted above the pivot with its Y axis vertical (i. e., "standing on the wing tip") and the lift and drag are measured simultaneously by hanging weights on two arms at right angles to each other and balancing the apparatus up in two planes at once. The leverage ratio in this balance, as in those in the N. P. L. 4-foot tunnels, is one-half, the distance from the main pivot to the center of the model being 137 cm. (54 inches), while that from the pivot to the scale-pan sockets at the ends of the weighing arms is 68.5 cm. (27 inches).

Assemblies and sections of the balance are given in Plates I-IV, and photographs of the completed instrument in Figs. 1 and 2. Figs. 3 to 10, inclusive, illustrate all the parts (except about 10 specially made parts and such stock hardware as machine screws and nuts) entering into the construction of the balance. Each part is numbered in these illustrations, and frequent reference will be made to them in discussing the working of various elements.

RIGID PARTS.

The frame is essentially the same as in the original N. P. L. balance, except that it is cast in one piece instead of having the head which carries the moving part of the instrument cast separate and bolted on. Furthermore, where the British design has only one member projecting from the frame head the Langley Field balance has three, one passing into the movable portion of the balance and carrying the socket for the main pivot, the other two passing around the outside of the movable portion and a little more than half encircling it. A cast-iron yoke is bolted to the ends of these encircling members, and the balance proper is then entirely surrounded by a ring, with just enough clearance to permit it to rock without danger of striking the frame.

¹ Report of British Advisory Committee for Aeronautics, 1912-13, pp. 61-66: London.

The object of thus encircling the balance with the frame was to provide a point of attachment for the guide arms. In the N. P. L. instrument they pass through holes cut in the sides of the moving portion and are bolted directly to the single frame lug which carries the main pivot socket. Since the Langley Field balance was designed to carry loads up to 20 kg. on the model some stronger method of attachment for the guide arms was required, as well as one which would permit of easier assembling and dismounting.

The guide arms are made of steel tubes, 25.4 mm. (1 inch) in outside diameter and with 5-mm. walls. They are pinned into sockets at the end, and these sockets are bolted directly to the frame or (in the case of the lift arm) to the yoke which connects to the frame and passes around the balance. The worst stress in the guide arms occurs when there is no weight on the weighing arms and the load on the model is at a maximum or when the wind is suddenly stopped with the weight in the scale-pans adjusted to balance a large load. With a load of 20 kg. acting on the model the force applied at the end of the guide arm is 40 kg., and the bending stress at the root of the arm is 1,475 kg. per square centimeter (21,000 pounds per square inch). The guide arms carry cages which slide in dovetailed slots and can be adjusted by screws through a vertical range of about 6 mm. in order to facilitate the preliminary lining up of the instrument with the lower pivot engaged. Instead of using a thread or wire as a reference line a piece of glass with a hair line scribed on it is mounted in the side of each cage. The weighing arms are nickel plated, and the reference line carried by the cage is lined up with its own reflection in the weighing arm and with a similar line scribed on that arm, thus avoiding any possibility of parallax due to the considerable distance between the two arms.

The dashpot is nearly identical with that on the N. P. L. instrument. It was cast with two passages, connecting opposite pairs of chambers, cored in the bottom, and a petcock communicates with each of those cored passages. This insures that the damping liquid will always stand at the same level in opposite chambers, but it is still possible to have it at different levels in adjacent chambers or to use liquids of different viscosities if it is desired to damp the oscillations in one plane more powerfully than those in the other.

BRAKE AND LOWER PIVOT SOCKET.

The brake, a short distance above the dashpot, is of a different type from that used by the N. P. L. as it was necessary to secure a very powerful grip, capable of resisting a large torsional moment, on the lower tube, but without risking crushing that thin-walled tube. The brake used is identical in principle with a lathe collet and gives a uniform pressure over virtually the entire circumference of the tube.

A mechanism for raising and lowering the lower pivot socket, causing engagement or release of the pivot, is mounted underneath the dashpot. The parts are illustrated and numbered in fig. 6. The handle 1 is fastened to the cam 4 and the rotation of this handle through a quarter turn raises the cam 3 by 10 mm. The adjusting screw 5 is screwed into 3 and transmits the vertical movement to the pivot socket 7 through the sleeve 6 and the spring 8; 7 rises freely until it comes in contact with the lower pivot, and thereafter, as 3 and the attached parts continue to rise, 8 is compressed, increasing the pressure between the pivot and its socket. When 3 has been raised to its maximum height the pressure between the pivot and socket can be adjusted by turning the screw 5 in the cam 3, two turns of the screw being sufficient to change the pressure from 0 to 20 kg. The spring 9, much weaker than 8, is used to assist gravity in throwing the socket out of engagement after the cam has been lowered. This device is very much quicker and easier to operate than the usual simple screw and spring, and it has the great advantage of permitting an adjustment of pressure for different lateral forces of the pivot against its socket and for different total weights to be carried. The load can thus be distributed between the upper and lower pivots in any manner desired.

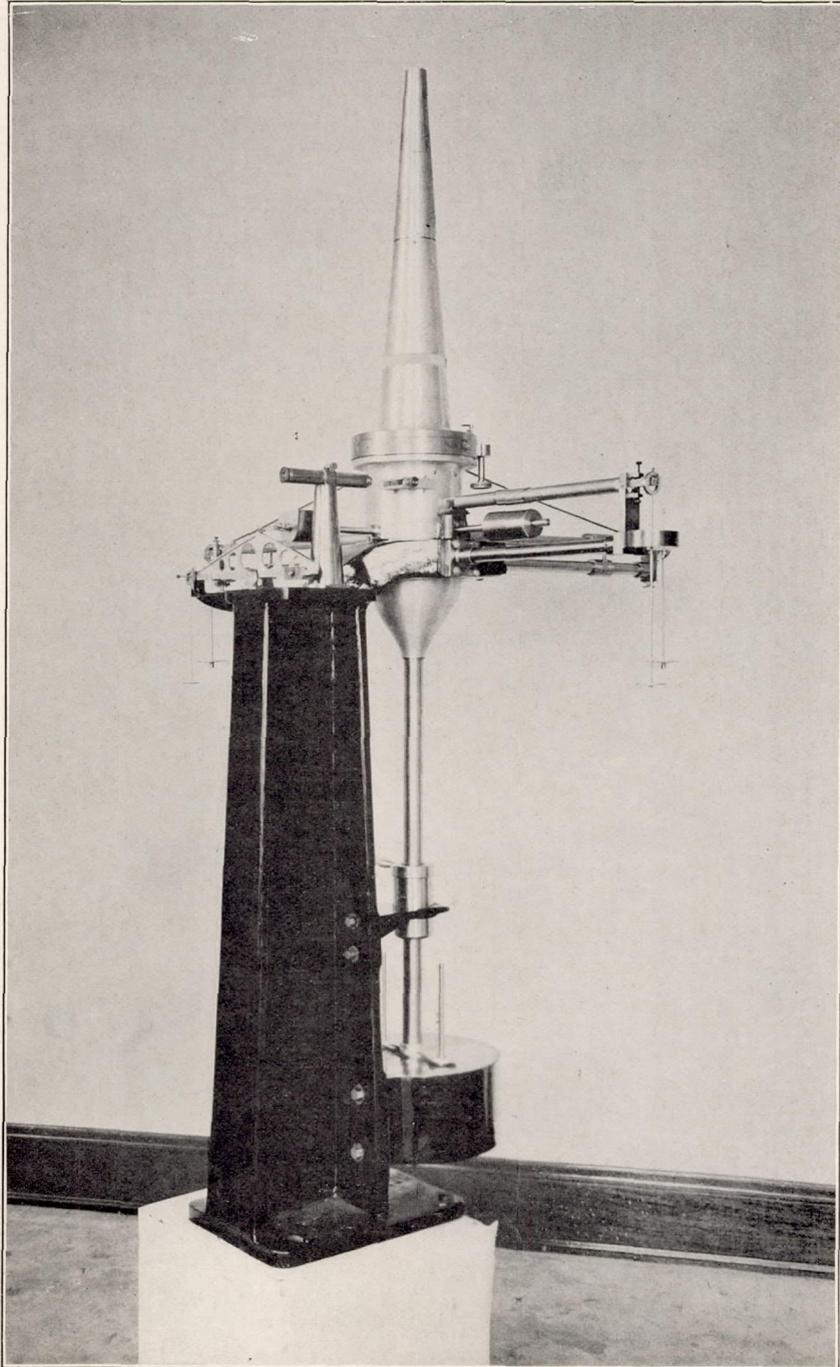

FIG. 1.

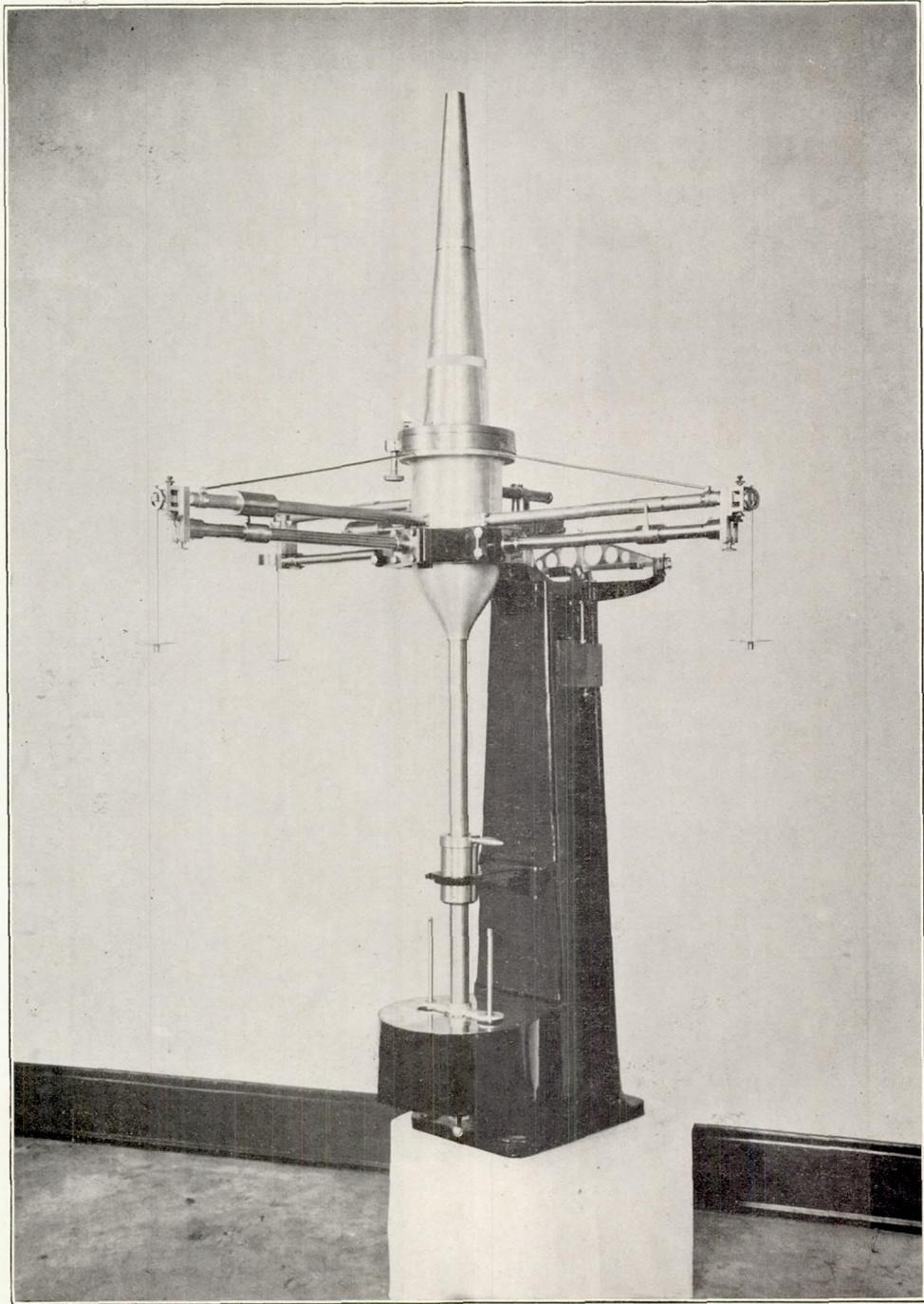

FIG. 2.

MOVING PARTS OF BALANCE.

In order to reduce the weight of the main pivot, the upper and lower parts of the balance were both cast of aluminum alloy instead of bronze, as has been the practice hitherto. Since an aluminum to aluminum bearing at the point where the pieces touch would be undesirable, a steel plate is screwed to the lower face of the upper part. This plate has teeth cut around its periphery, and these mesh with the teeth on the pinion whose case is mounted on the clamping ring (to be described later). By rotating the pinion knob the upper part of the balance is turned with reference to the lower part and the angle of incidence can thus be adjusted very accurately. The main balance castings were proportioned for stiffness and for reasonable ease of construction, rather than from the standpoint of stress. The maximum bending stress in the lower head is 29 kg. per square centimeter, giving a factor of safety of about 40, and that in the upper head is quite as large.

The force acting on the balance, and tending to separate the upper and lower heads on one side while forcing them together on the other, is too great to permit the use of the T-slot arrangement employed by the N. P. L., and the two pieces were therefore clamped together by an alloy-steel ring threaded onto the lower part and with a flange turned inward and bearing against the upper portion. This ring is one of the few parts of the balance which is probably materially stronger and heavier than it needs to be. The stress in such a flange is difficult to compute with accuracy because of uncertainty as to the distribution of the pressure between the surfaces, but it is estimated on the best assumptions available, as 700 kg. per square centimeter (10,000 pounds per square inch), giving a factor of safety of over 10. It would be safe to reduce the maximum thickness of the clamping ring and its flange to 3 mm. (three-sixteenths inch), and the weight could thus be reduced by about 500 gms.

The clamping ring covers up the portion of the upper head which normally bears the graduated circle, and the graduations have therefore been transferred to the horizontal portion of that head, just inside the inner edge of the clamping ring flange. Since this is too high from the floor to be convenient for direct observation, a prism is mounted on the clamping ring so that the graduations can be read with the eye on a level with the plane dividing the two parts of the balance. A movable vernier is mounted at the same point and its graduations are also reflected in the prism.

The weighing-arms, instead of being cantilevers, as in previous balances of this type, are trussed with tie-rods. The arms are made of steel tubes 25.4 mm. (1 inch) in diameter, with walls 1.5 mm. (0.06 inch) thick, and are trussed with rods 4.5 mm. in diameter, making an angle of $12^{\circ}.5$ with the arms themselves. The compressive stress in the arms under the maximum load is 159 kg. per square centimeter (2,260 pounds per square inch) and the tensile stress in the tie-rods is 943 kg. per square centimeter (13,400 pounds per square inch). In order to carry the same load with solid arms acting as cantilevers they would have to be 24 mm. in diameter, or approximately the same as the outside diameter of the thin-walled tubes now used. The deflection with cantilever arms would be much greater than with trussed, and the weight would be at least twice as great as the weight of the present arrangement.

Counterweights are provided for lift and drag. The lift counterweight is made flat on top so that more weight can be easily attached there when large negative lifts have to be measured, by removing part of the weight placed in the scalepan to balance the counterweight. Since negative drags never occur, the same necessity of adding weight does not arise for the drag counterweight.

The main pivot is carried in a ribbed plate cast of aluminum alloy and fixed inside the lower part of the balance. This plate carries, in addition to the main pivot, two pivots and two knife-edges, arranged around the circumference of a circle. All five pivots and knife-edges lie on the same level. The balance frame carries, in addition to the main pivot socket, a pivot socket and a knife-edge socket in line with the lift arm and a little lower than the main socket. When it is desired to measure drag alone the main pivot is lowered with a special wrench inserted through a slot cut in the slide of the balance, and the balance is dropped until one of the

secondary pivots and one of the knife-edges mentioned above come into contact with their sockets, just as in the original N. P. L. instrument. The balance then has only 1 degree of freedom and the lift arm can be disregarded entirely unless the lift is very large, in which case enough weight should be hung on the lift arm to balance the lift approximately (within 1 or 2 kg.). If this is not done the weight of the balance may be insufficient to hold it down, and the pivot may rise from its socket entirely. The other pivot and knife-edge are used to measure lift alone. Their sockets are carried by a horseshoe-shaped link, pivoted to the frame at its open end and resting at the other end against the point of a screw which is threaded into the frame. This pair of sockets are in line with the drag arm and are normally a little lower than the pair used for measuring drag alone. When it is desired to measure lift alone, the screw supporting the closed end of the link is turned, raising the link and its pair of sockets until the sockets come in contact with the pivot and knife-edge and lift the balance off of the main pivot. The balance is therefore a little above its normal position when lift alone is being measured and a little below it when it is the drag that is taken, but the total vertical displacement does not exceed 2 mm.

The four dashpot fins and the platform on which the "sensitivity weights" rest are made of a single aluminum casting in order to get the weights as far as possible below the center of gravity.

The drawings and photographs show the balance only as far as the upper end of the trumpet top. Beyond this comes the spindle, which presents a special problem in that not only the weight and strength, but the outside diameter, must be taken into consideration, as the interference of the spindle with the flow about the wing is always a serious factor, and no effort must be spared to reduce it. It is very desirable that the wing be supported by the tip, as the interference of a center support is much greater. With a spindle attached at the wing-tip, the whole force on the model acts at a large moment arm to produce bending stress in the spindle. With a wing 60 by 10 cm. and a force of 20 kg., a spindle of mild steel has to be at least 16 mm. in diameter at the point of attachment to the wing to give a factor of safety of 4. With a spindle of high-grade heat-treated alloy steel this diameter can be reduced to 12 mm. For uniform stress, the spindle diameter at the trumpet top would be only 21 per cent greater than that at the wing, but it is well to taper a little more abruptly than this in order to secure increased stiffness. When the parasite resistance of bodies, airship hulls, or other streamline forms is being determined a very much smaller spindle can be used than when wings are being tested. With an airship hull of low resistance coefficient, the model being 12 cm. in diameter and being tested at a speed of 50 meters per second, the spindle diameter at the point of attachment need be only 1.9 mm. in diameter, tapering to 2.8 mm. at a distance of 15 mm. Here again a sharper taper would be advisable to reduce the deflection and avoid vibration of the model. In any case, however, a correction for the effect of spindle deflection (discussed in another section of this report) would be necessary with a spindle of such a small tip diameter as this.

PITCHING MOMENT DEVICE.

The torsion wire used by the N. P. L. for measuring pitching moments being unsatisfactory in some respects a secondary balance beam for weighing these moments directly is incorporated in the Langley Field instrument, as in that at the Bureau of Standards and several others. The moment weighing arm is an aluminum casting. The moment is transmitted to it from the lift counterweight arm of the balance through a strut and spring clamp similar to those used by the N. P. L. for preventing rotation of the balance, and is balanced by weight hung at the end of the horizontal beam of the weighing arm. The ratio between the lengths of the horizontal and vertical arms is 3, so that the weight in the scalepan is one-third the lateral pressure of the strut or clamp against the socket at the top of the weighing beam. If the lateral pressure becomes greater than the total weight of the beam and parts attached to it the knife-edges on which the beam rocks will jump out of their sockets, the sides of which have a slope of 45°. When tests are made at high speeds and with models so mounted that the pitching

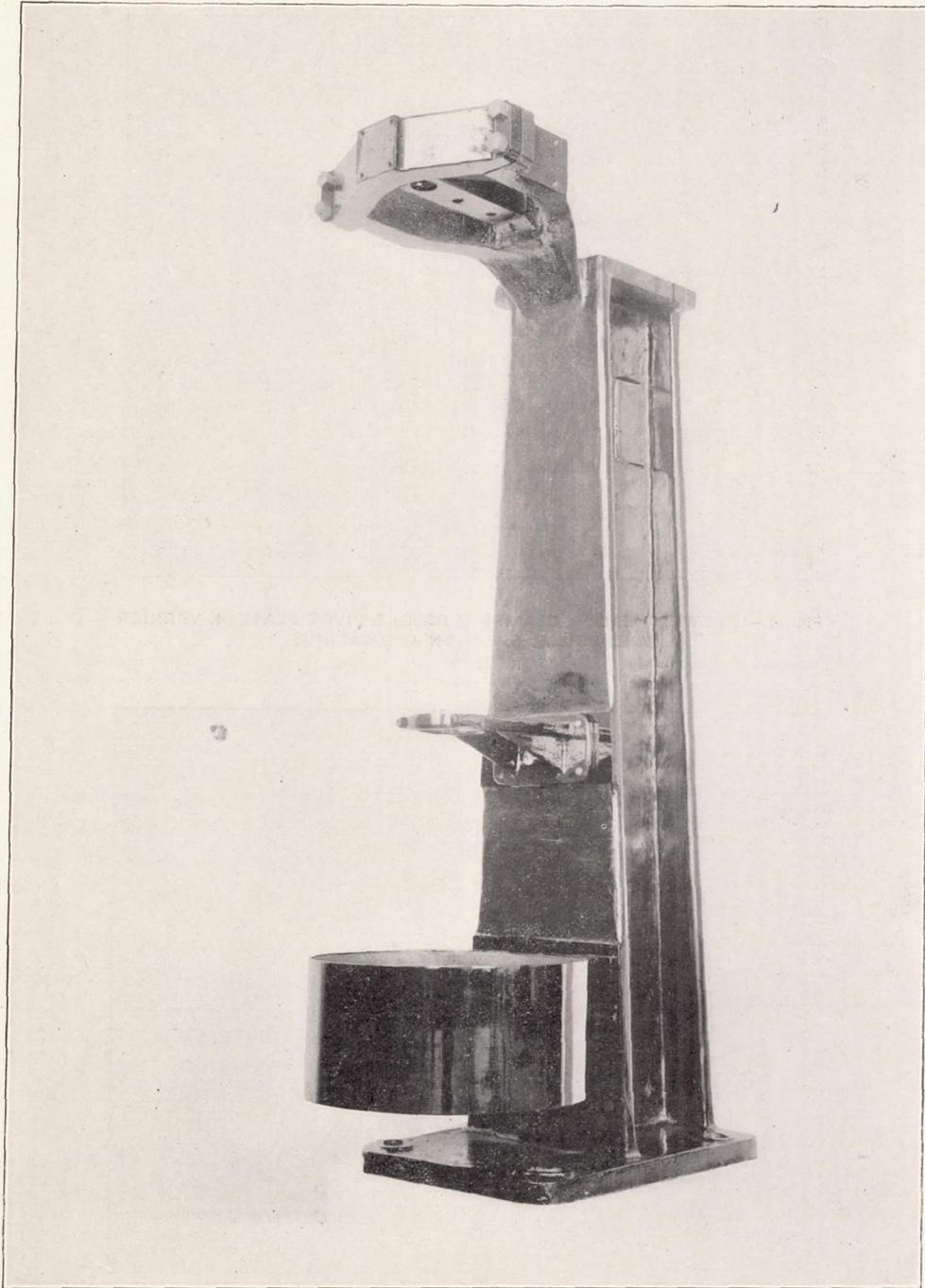

FIG. 3.—FRAME, DASHPOT, AND OTHER RIGID PARTS.

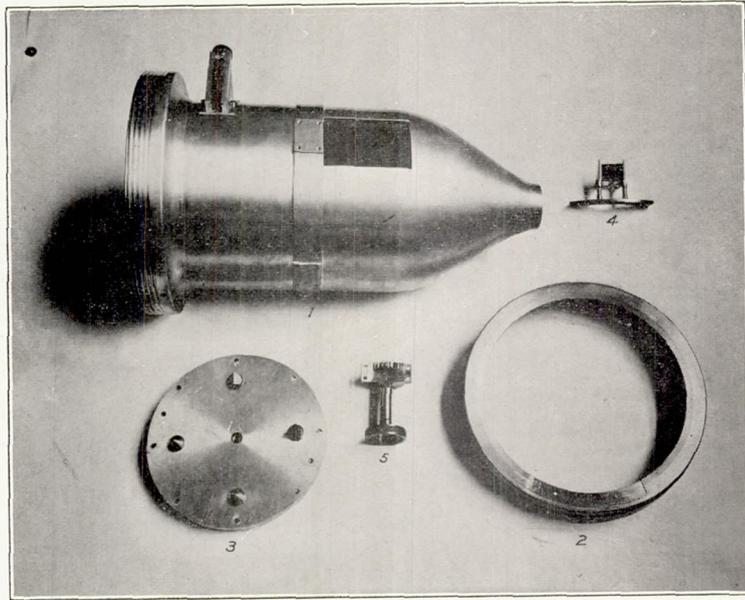

FIG. 4.—1, LOWER HEAD; 2, CLAMPING RING; 3, PIVOT PLATE; 4, VERNIER AND PRISM; 5, PINION AND CASING.



FIG. 5.—1, UPPER HEAD; 2, TRUMPET TOP; 3, 4, PIVOT AND KNIFE-EDGE SOCKETS; 5, 6, BUSHINGS; 7, DASHPOT COVER.

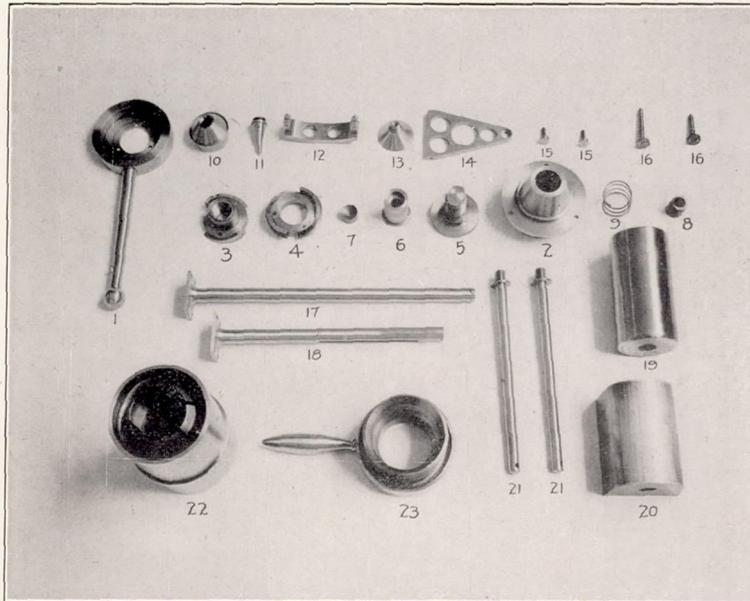

FIG. 6.—1 TO 11, LOWER PIVOT AND LOWER PIVOT SOCKET PARTS; 12, V. F. LINK FRAME; 13, V. F. ROD SOCKET; 14, V. F. LINK; 17, 18, COUNTERWEIGHT ARMS; 19, 20, COUNTERWEIGHTS; 21, SENSITIVITY WEIGHT SPINDLES; 22, 23, BRAKE PARTS.

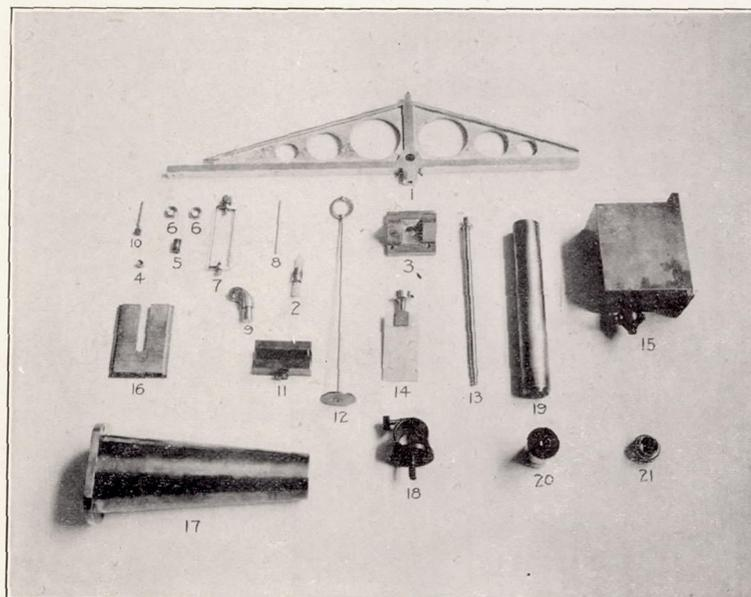

FIG. 7.—1 TO 16, MOMENT DEVICE PARTS; 17 TO 21, MICROSCOPE PARTS.

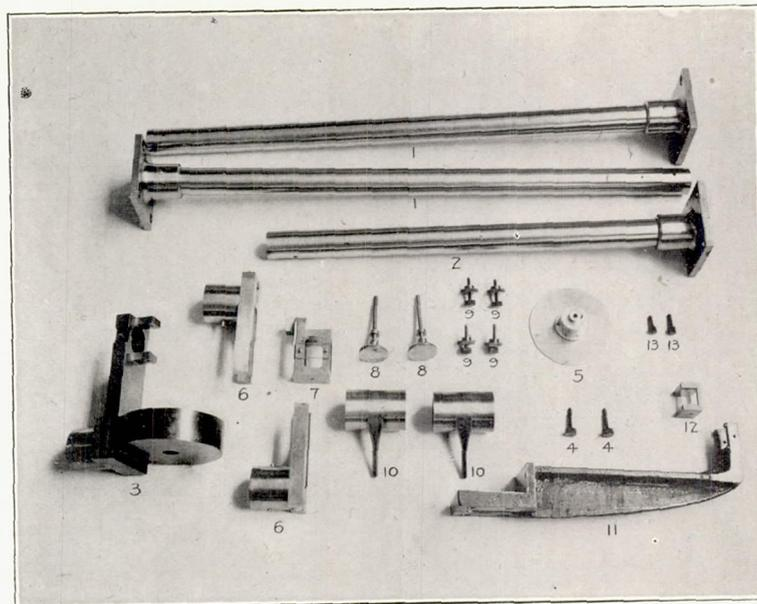

FIG. 8.—1, 2, GUIDE ARMS; 3, V. F. CAGE AND DASHPOT; 5, V. F. DAMPING VANE; 6, 7, CAGE CARRIER AND CAGE; 10, RIDER PUSHERS; 11, 12, MOMENT GUIDE ARM AND CAGE.

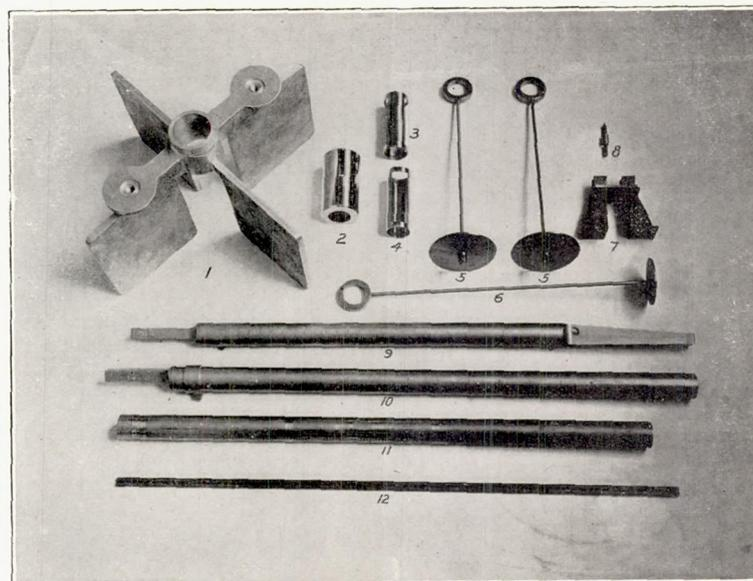

FIG. 9.—1, DASHPOT FINS; 2, 3, 4, RIDERS; 5, 6, SCALE PANS; 7, V. F. KNIFE-EDGE FRAME; 9, 10, 11, WEIGHING ARMS; 12, WEIGHING ARM TIE-RODS.

moment is large it is therefore necessary to add dead weight to the weighing beam to hold it down. A counterweight is placed opposite the scalepan on which the weights to balance the moment are hung, and this counterweight is heavy enough and placed far enough from the axis of rotation of the beam so that the zero weight which must be placed in the scalepan to balance the beam with no wind on is greater than the largest diving moment which is likely to be measured. Both stalling and diving moments can thus be measured with a single scalepan.

The spring clamp used for transmitting the moment to the weighing beam is made with a single helical spring behind one pivot. The pressure of this spring can be adjusted by turning the knurled head of the clamp. A C-spring of the type used on earlier N. P. L. balances could not be made to give the requisite pressure and still be kept within reasonable limits of size. The strut which opposes the spring clamp is made of a steel tube, 3 mm. outside diameter, 1.5 mm. inside diameter, with hardened points mounted in its ends.

A separate dashpot is provided for damping the oscillations of the moment weighing arm. The damping fin is carried at the lower end of a rod which runs down through a slot in the table top of the balance frame.

When lift and drag are to be measured the moment beam is locked, in order to prevent rotation of the balance about a vertical axis, by passing a pin through holes drilled in the sides of the moment guide arm and in the weighing arm itself. The balance can be adjusted for alignment of the arms with the wind by moving the socket which is set in the lift counterweight arm and which is provided with a screw adjustment.

MICROSCOPE FOR ALIGNMENT.

In order to check the alignment of the arms with the wind, a microscope is mounted on the table top of the balance frame, and a reference line is carried on the balance itself, exactly as in the original instrument except for mechanical details. The reference line is made adjustable with a micrometer screw in order that it may be brought into line with the cross hair of the microscope when the alignment is first determined or whenever it is checked. The reference line, once located, is left fixed, and the two lines are thereafter brought into alignment, whenever they get out from any cause, by moving the strut-and-spring clamp socket as described in the last section. Ordinarily the lines should come into register whenever the locking pin is passed through the moment weighing arm without any adjustment.

VERTICAL FORCE ARM.

When lateral stability or control is to be investigated, requiring the measurement of six forces and moments instead of three, the model is set up with the Y-axis horizontal and the lift is measured directly on the vertical force arm, which runs in the opposite direction from the drag arm. The method used in the Advisory Committee's balance is identical with that devised and used by the N. P. L., and fully described in the Report of the British Advisory Committee for Aeronautics for 1912-13. Since the lift on a wind tunnel model at high speeds is greater than the weight of the model, enough weights are strung on the vertical rod which passes inside the balance to insure that the total weight on the inner end of the V. F. weighing arm will be greater than the maximum lift.

CONCLUSION.

While it is perhaps unwise to attempt to set a limit to future progress in any direction, it is not believed that the N. P. L. type of balance will prove applicable to tunnel sizes and wind speeds very much in excess of those at present realized. The load becomes too great for a single pivot, the errors due to deflection rapidly run up with the size of balance, and the handling of the weights becomes an arduous task with growing forces on the model. Even in the present balance 40 kg. must be lifted onto the scalepan to balance the maximum lift. If there is to be much further increase in the values of LV reached in model experiments, that increase probably must be accompanied by the adoption of a new type of weighing instrument.

REPORT No. 72.

PART II.

SENSITIVITY OF WIND TUNNEL BALANCES OF THE N. P. L. TYPE.

The balances used in aerodynamic measurements, whatever may be their type, work under conditions radically different from those to which practically all other weighing machines are exposed in that the load acting on the balance is never steady, but varies with the greatest rapidity. In a chemical balance the action of gravity on the weights and on the substance to be weighed is absolutely unchanging, assuming an absence of chemical or physical action with the surrounding air, and the only variable forces are those due to the currents of air striking the balance. In a good balance even these are guarded against by the inclosure of the balance in a case, means being provided for manipulating the weights from outside.

When it is attempted to measure forces due to fluid velocity the whole problem of instrument design is much altered, for it becomes necessary to balance a fixed force, the pull of gravity on the weights, against a variable one, the pressure on the object being tested. It was with the object of eliminating this dissymmetry that Lanchester devised, a number of years ago, his aerodynamic balance in which the two forces balanced against each other varied in the same way. In this instrument, used chiefly for finding the skin friction of plates, the object to be tested was held at one end of a horizontal arm, the other end of which supported a small flat plate so oriented as to be normal to the wind. The horizontal arm was free to rotate about a vertical axis through its center. In use the apparatus was exposed to a rapidly moving current of air, and the area or position, or both, of the normal flat plate, were varied until the arm showed no tendency to rotate. The moments about the axis were then equal and, since the distance of each surface from the center of rotation could be measured and since the resistance of normal flat plates had already been determined with a fair degree of accuracy by other experimenters, using other methods, it was possible to solve for the unknown resistance. Once the arm on this instrument was balanced, it should show no tendency to rotate due to changes in wind velocity, provided the velocity at any given instant was the same at the two ends of the arm, as the resistance of each object was very nearly proportional to the square of the velocity, and the ratio of the resistances would be quite independent of wind speed. For this same reason, indeed, measurements of the wind speed were wholly unnecessary for the determination of the coefficients. A device similar in conception was used by Dines at about the same time for measuring resistances. In this case the surface tested was carried on a whirling arm, and the resistance was balanced against the centrifugal force on a weight connected to the surface through a bell crank. Here, again, no measurement of speed was required, as the resistance of the object tested and the centrifugal force on the weight were both proportional to the square of the angular velocity of the whirling arm. An arrangement for balancing the force on two surfaces against each other is also used in Mr. Orville Wright's balance.

Such devices as these, however great their ingenuity, are inevitably unsatisfactory in some respects. In the first type described, a preliminary determination of the resistance coefficient for a flat plate normal to the wind was required, and the accuracy of all subsequent experiments was limited by the accuracy of this preliminary determination. No absolute measurements of resistance were possible. In both cases the mechanical complications introduced by the shifting of a surface or of a bob weight were extreme.

In nearly all balances used in aerodynamical laboratories at the present time, then, to return to the original statement, fixed and variable forces are involved. No satisfactory means of automatically controlling the wind velocity in a tunnel has yet been devised, despite the considerable number of trials which have been made, and it is still necessary to depend on manual regulation. This involves a distinct time lag between the occurrence of a velocity fluctuation and its correction by the manipulation of the rheostat, so that, even with a highly skilled operator, the wind velocity may vary more than $\frac{1}{2}$ per cent each way from the mean value, the period of the velocity oscillation being from 2 to 10 seconds. A variation of $\frac{1}{2}$ per cent in the wind velocity implies, since the forces vary as the velocity squared, a variation of 1 per cent in the forces acting on the model. The magnitude and nature of this variation must be kept always in mind in designing the balance, and the instrument must be so arranged as to yield the most accurate results possible under the special conditions which it has to meet.

We shall examine first the sensitivity of the type of balance originated at the National Physical Laboratory and used in this country at the Massachusetts Institute of Technology,

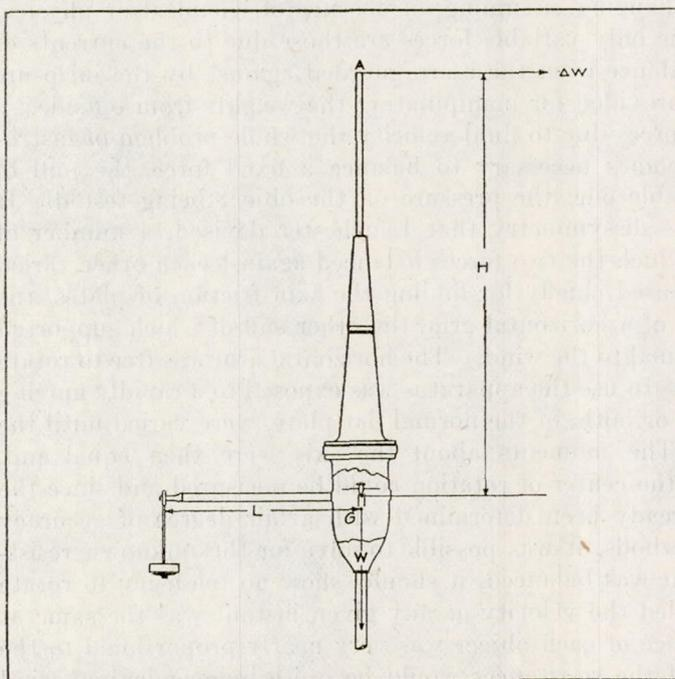

FIGURE 10.

at the new tunnel of the Curtiss Engineering Corporation, and in the Advisory Committee's tunnel now under discussion, in which a single pivot is used for support and the balance has two degrees of freedom.

In the first place, since it is necessary to balance up the instrument with no wind blowing in order to determine the amount of weight required to counterbalance the statical couple due to the model and the weight of the unsymmetrically disposed portions of the instrument, there must be a sufficient degree of "statical sensitivity," working as an ordinary physical balance, to keep the error in the readings on this preliminary test within reasonable bounds.

The magnitude of the error permissible depends upon the greatest absolute accuracy desired in the determination of lift or drag. In the case

of a wing, this greatest accuracy is required in the measurement of the drag near those angles where the drag coefficient is a minimum. The minimum drag of a wing 60 by 10 cm. at a wind speed of 30 m. per second is about 72 g. In order that the error in the determination of this amount may not be over 1 per cent, the possible error in the preliminary run with no wind on should under no conditions exceed $\frac{1}{2}$ per cent of the quantity to be measured, or, roughly, 0.35 g. In order that the measurement may be accurate to this amount it is necessary to make the theoretical sensitivity quite a little better than 0.35 g., as there is always some friction between a pivot and its socket, especially where, as in an instrument of this type, the pivot must be somewhat blunted in order that it may carry its load without crushing. In actual practice with heavy pivot-supported aerodynamic balances, it is found to be possible to secure a distinct movement of the drag arm due to changes of weight of 0.05 g. The lift arm is somewhat less sensitive, as motions of this arm are opposed not only by the friction between the pivot and its socket, but also by the friction between the lift counterweight arm and the two pivots (on the strut and spring clamp) which prevent rotation of the balance about a vertical axis. A sensitivity of 0.05 g., while it is sometimes useful when the forces to be measured are very small, as in the determination of the resistance of a streamline

body, is seldom required and seldom obtained. In general, if means be provided for adjusting the balance to give a sensitivity of 0.1 g., the results will be perfectly satisfactory.

The forces acting on the balance with no wind blowing are shown diagrammatically in figure 10. G is the combined center of gravity of the moving portions of the balance, the model, and the weights required to balance the unsymmetrically disposed portions of the model and of the instrument itself and is located at a distance x_0 below the pivot. These weights are, of course, considered as applied at the point where the scalepan pivot touches its socket in the weighing arm. W is the sum of all these weights (balance, model, etc.). If a force Δw be applied at the point A or, what amounts to the same thing, if the weight on the scalepan be decreased by $k\Delta w$ where k is the multiplication ratio between the vertical and the horizontal arms of the balance, the balance will, neglecting friction, rotate about the pivot through an angle whose circular measure is equal to $\frac{h\Delta w}{Wx_0}$. The vertical movement of the reference line at the end of the weighing arm will then be $\frac{hl\Delta w}{Wx_0}$. If a certain value ϵ be assumed for the minimum perceptible value of this movement the sensitivity is given by the expression: $\Delta w = \frac{Wx_0\epsilon}{h \times l}$. An increase of sensitivity requires decrease of Δw , and this can be secured by modifying any one of four terms (it is assumed that ϵ can not be further decreased except by the use of a microscope for observing the movements of the reference line). W is always reduced to as low a value as possible if for no other reason than to keep down the load on the pivot, but there are well defined limits beyond which this reduction can not proceed without sacrificing the strength and stiffness of the instrument to an extent which will introduce large errors.

It would appear from the formula that Δw could be reduced by increasing h or l , or both, but this is not actually the case, since any increase in these quantities requires more than a proportionate increase in weight in order to keep the deflection of the structure within safe limits. h is always made as small as possible without bringing the enlarged sections of the balance head close enough to the edge of the wind stream to interfere with the flow of air. l is made as short as has been found expedient (usually $l = \frac{1}{2} h$) as any shortening of l rapidly increases the amount of weight which must be handled and the load on the pivot. There remains, among the several variables, only x_0 , and this can be reduced practically without limit. Here again the conditions under which wind tunnel balances work are peculiar. Whereas, in the ordinary scientific balance, it is necessary only to construct the beam and attached parts so that their combined center of gravity will be very slightly below the knife-edge and then to place the knife-edge sockets for the scalepans so that a straight line connecting them will pass through the knife-edge supporting the beam, thus making the sensitivity independent of the weight in the scale pans, in the case of the wind tunnel balance neither the total weight of the rigidly assembled moving parts nor the position of their center of gravity ever remains fixed for two consecutive tests (unless they be made on the same model under identical conditions). In the case of the Langley Field tunnel, for example, the weight of the model and of the spindle which supports it may lie anywhere between 50 and 10,000 g. Since the center of gravity of the model is about 140 cm. above the center of gravity of the rest of the balance, the effect of changing from the lightest to the heaviest model is to raise the center of gravity of the whole assembly by about 60 cm. Manifestly, if x_0 was very small with the light model in place, it would have a large negative value when the heavy one was substituted, and the balance would be unstable. On the other hand, if x_0 was adjusted for a small positive value with the heavy model its magnitude would greatly increase on changing over to the light one, Δw would therefore be augmented manyfold, and the sensitivity of the measurement would be much decreased just when the highest possible degree of accuracy would be required; that is, with a small model experiencing only small forces. It is therefore necessary to provide some means of adjusting the center of gravity when the weight of model is changed, and this is done by means of the "sensitivity weights" carried on the spindles just above the dash-pot (shown in the side view

in the general assembly drawings of the Advisory Committee's balance). When the weight of the model is large, a large amount of weight is placed on the spindles, about 70 cm. below the pivot, thus counteracting the tendency of the heavy model to raise the center of gravity. When there is no model in position a weight of about 800 g. is required on the spindles to balance the capsizing tendency of the balance itself, and an additional amount of about twice the weight of the model is required to maintain stable equilibrium with the model in place.

In the particular case of the committee's balance W , in the formula for sensitivity, is 20,700 g., not including the model, the weight in the scalepan, or any sensitivity weights except those required to balance the upsetting tendency of the balance itself. With a model in position and no wind on, the total weight supported on the pivot lies, in most cases, between 21,000 g. and 49,000 g., with an average value of about 28,000 g. h is 54 inches, or about 137 cm., and l is 27 inches, approximately 68.5 cm. ϵ may be taken as 0.2 mm. If the required sensitivity be taken as 0.1 g., which was shown above to be a fair average value, x_0 must not be more than 1.7 cm. On the other hand, x_0 must not, under any conditions, be negative, as the balance will simply fall from side to side, never being in stable equilibrium, and it will be almost impossible to secure any readings whatever. Since a movement of 0.2 mm. at the end of the weighing arm corresponds to an angular rotation of 0.00029 radian, the product of the total weight and the distance from the pivot to the center of gravity may vary, without falling below the minimum permissible sensitivity, from 0 to 47,000 gm. cm. Since the sensitivity weights are located about 70 cm. below the pivot a variation of nearly 800 g. in the amount of weight used is possible without changing the sensitivity beyond the assigned limits. A somewhat closer adjustment than this is actually sought for, as it is not desirable, as will be shown later, to have too much sensitivity, but there is no necessity for changing the weights by smaller intervals than 200 g. Since the weight is always symmetrically disposed on the two spindles the smallest weight used is 100 g.

With the wind on the conditions are changed considerably. All the forces which acted during the preliminary run continue in operation, in addition to two new ones, the resultant force on the model due to the reaction of the moving air and the weight used to balance this resultant. (Lift and drag are here considered as a unit. Strictly speaking, of course, there are three forces acting—the resultant force due to the air, the pull of gravity on the lift weights, and the pull of gravity on the drag weights.) The moments of these two new forces about the balance pivot must be equal in order that the system may continue in equilibrium.

The conditions of stability of the system are also modified. The addition of weight to the scalepans has no effect, provided that the socket for the scalepan pivot is, as it should be, exactly in the horizontal plane through the main pivot when the balance is in equilibrium. Since there is inevitably some deflection of the weighing arms, no matter how well they may be braced, this condition can not be exactly obtained under all loads, but the deviation from the ideal is small. The magnitude of this deflection and the errors arising from it are examined in another part of the paper.

If the line of action of the force on the model intersects the vertical line through the pivot the change in moment arm due to small inclinations of the balance is negligible, and the moment of the force about the pivot remains substantially constant during the oscillations of the balance, so long as the force itself is not varied by fluctuations in the wind velocity or any other cause. If, however, the force does not act through a point vertically over the pivot the two forces supposed to be in equilibrium (that due to the pressure of the air on the model and that due to the pull of gravity on the added weights) will not continue in equilibrium when the balance inclines, and loss of sensitivity or loss of stability of the system will result, just as is the case when, in an ordinary physical balance, the line connecting the points of suspension of the scalepans passes below or above the knife-edges. It is rather difficult to define satisfactorily the point which, being analogous to the point of suspension of a scalepan, should be located directly above the pivot. For the present, at least, it will be simplest to consider separately the effects of each of the six forces and moments acting on an object, not necessarily symmetrical, exposed to a current of air.

Instead of considering the lift and drag, acting perpendicular and parallel to the relative wind, as is the ordinary practice in wind tunnel work, it will be best to deal with the forces resolved parallel to axes fixed in the model, in accordance with the current practice in stability work. In this way the moment arm of each force about the pivot will be fixed, whatever oscillations the balance may undergo. The three forces are taken as acting at an origin which may be arbitrarily fixed, but which is almost always located at the center of gravity in the case of a model of a complete airplane and at the center of the leading edge in the case of an aerofoil.

Oscillations of the lift arm of the balance can obviously have no effect on the sensitivity. Their only result is to incline the plane of the wings out of the vertical. This does not change the magnitudes of any of the forces along axes fixed in the model, nor of the moments about such axes, and, since the moment arms are constant, as pointed out above, the moments themselves will not change.

Oscillations of the drag arm, however, yaw the model instead of rolling it. As soon as the model yaws symmetry is destroyed and all of the forces and moments may be modified in some degree. The variations of the pitching moment are of no interest in the present connection, as the moment is exerted about a vertical axis, and can not possibly affect the equilibrium of the balance. Its only effect on the sensitivity is to change the pressure of the short balance arm against the strut which prevents the balance from rotating about a vertical axis, and so to change the friction at this point. Of the five quantities remaining, the variations in the forces Z and X , closely analogous to the lift and drag, are small, but not so small as to be negligible. In general, Z decreases slightly with small deviations from the position of symmetry, while X increases, but exceptions to both of these rules are sometimes encountered. The rate of decrease of Z is usually about one-half of 1 per cent for each degree of yaw. The change in X usually ranges from $\frac{1}{4}$ per cent to $1\frac{1}{2}$ per cent increase for each degree of yaw. Since the oscillations of the two arms of the balance are usually synchronous, both being governed by the variations in wind velocity, the effect of the movements of the drag arm, causing the model to take up an angle of yaw, on the lift must not be neglected. Since for a model of an airplane or other symmetrical object, the direction of change of X and Z is the same for a positive as for a negative angle of yaw, the effect of the changes is to assist a return to the position of equilibrium when the deviation is in one direction from that position and to oppose it when the deviation is in the other direction. If the initial sensitivity (with no wind on) is very great there is danger that this added moment opposing a return to equilibrium may be large enough to overcome the righting moment due to the weight of the balance. The result of this will be somewhat the same as the result of using insufficient counterweight to balance a heavy model, but the instability in this case will appear only for motions in one direction from the central position, and will usually lead to an underestimation of the lift and an exaggeration of the drag. To find the limitation thus placed on the maximum initial sensitivity the same method may be employed as that already used for finding the minimum permissible initial sensitivity. If the rate of change of longitudinal force be taken as 1 per cent per degree of yaw the upsetting moment due to a movement of the balance through the angle $\Delta\theta$ (circular measure) is $.57X \times \Delta\theta \times h$. For continued stability, this must be less than the righting moment due to gravity, $Wx_0\Delta\theta$. Equating the two, the condition of stability becomes

$$Wx_0 = > 0.57Xh$$

It has already been shown that the initial sensitivity is given by the expression:

$$\Delta w = \frac{W \times X_0 \times \epsilon}{h \times l}$$

In the case of the Langley Field balance, substituting $0.57Xh$ for Wx_0 , and the values previously specified for l and ϵ , the limiting value of the sensitivity is found to be

$$\Delta w = \frac{0.57X \times \epsilon}{l}$$

$$\frac{w}{X} = \frac{0.57\epsilon}{l} = \frac{0.57 \times 0.02}{68.5} = 0.00015$$

The same method may be applied to the lift and leads to the conclusion that, with a model having a lift of 20 kg., the initial sensitivity must not be greater than 1.5 gms. This would be an extreme value of the lift, and it is seldom necessary to reduce the sensitivity below 0.5 gm. on account of the variation in lift, but, on the other hand, it is seldom that actual use could be made of the sensitivity of 0.1 gm., previously taken as the standard for which it was necessary to provide. Only on stream-line bodies, struts, and similar objects of small resistance would the possible accuracy of measurement be as great as this. It is in some respects a disadvantage of the N. P. L. type of balance that its "statical sensitivity" must be the same in respect of lift and drag.

Y , the third of the three forces acting on the model, is perpendicular to the plane of symmetry, and does not exist so long as the wind direction is parallel to that plane. As soon as the balance moves from its position of equilibrium, however, the model assumes an angle of yaw, and this gives rise to a force Y which is almost always negative for a positive angle of yaw and vice versa. The magnitude of Y for a given angle of yaw varies widely with the type of model and with conditions of test, generally being largest, relatively to the lift, at small angles of attack. The absolute values of Y are virtually independent of the angle of attack. For an angle of yaw of 1° , Y may be as high as 2 per cent of the lift for complete models at an angle of attack of 0° , or about 1 per cent of the lift at 4° . This force is largest when the wings have a considerable amount of dihedral or sweep back. In the case of fair-shaped objects, such as airplane bodies and airship envelopes, Y at an angle of yaw of 1° is usually from 10 per cent to 35 per cent of X . With models of the size used in the Langley Field wind tunnel, and with a wind speed of 50 m. per second, Y has a maximum value of about 50 gms. for bodies and 100 gms. for complete models.

If the origin of the reference axes is directly over the pivot when in equilibrium Y has no effect, as its line of action always passes through the pivot. If, however, as is usually the case, the model is set up with the origin forward of the vertical through the pivot Y will tend to produce instability in respect of the drag measurements, while not affecting the movements of the lift arm. If the origin is above (in the model, not in the tunnel; i. e., nearer to the upper wing than) the vertical through the pivot Y will tend to decrease the sensitivity in lift, assuming that the two arms oscillate synchronously, without affecting the measurements of drag. The opposite positions will, of course, have opposite effects. The magnitudes of these effects are very small. They would seldom modify the sensitivity by more than 0.02 gm., and they need not be taken into account, provided that the model is so supported that the origin is reasonably close to (within 8 cm., in the case of a tunnel 1.5 meters in diameter) the vertical through the main balance pivot.

There remain only the yawing and rolling moments to be considered. Both of these, denoted by N and L , respectively, make their appearance, like Y , as a result of the assumption of an angle of yaw, and do not exist while the wind direction is parallel to the plane of symmetry. The analysis of the action of these moments need not be followed through in detail. The first is unimportant, while the rolling moment, which may assume a considerable value in the case of a model or a wing with marked sweep back or dihedral, acts to increase the sensitivity in lift, and is therefore opposed to the effect of the change of lift itself for motions in one direction, while acting with it for motions in the opposite direction from the central position. The maximum value of the effect of the rolling moment is about 15 per cent of the maximum unstabilizing effect which may arise due to changes of the lift with angle of yaw.

It appears from this consideration of the various forces and moments and their variations that their effects on the sensitivity of the balance are usually very slight, but that they may become important, especially with regard to the lift measurements, for some models. Since the most important factors are the variation of the lift and drag, and since the magnitudes of these forces and the moment arms at which they act are quite independent of the location of the model with respect to the vertical through the pivot, this location has less effect on the sensitivity than might have been anticipated, although it is by no means a factor to be neglected. The position at which the spindle supporting the model is attached can be chosen, within fairly wide limits, from considerations of ease of attachment and of minimum interference with air flow about the model, rather than with any idea of modifying the effects of Y , L , and N .

The distribution of the effect on sensitivity of the three factors variable with position (Y , L , and N) depends on the location in the model of the arbitrarily chosen origin, and any one of these three can be made to have any desired effect by properly placing the origin. The total effect of the three, however, will manifestly be entirely independent of the position of that point.

There are certain types of balance in which the model moves always parallel to itself, and the forces accordingly are subject to no change during the oscillation of the instrument. These will be briefly discussed later.

REPORT No. 72.

PART III.

POSSIBLE SOURCES OF ERROR IN BALANCES OF THE N. P. L. TYPE.

In order that some conception may be gained as to the relative accuracy necessary in the construction of the various parts of a balance, and as to the magnitudes of the errors which creep into the measurements from many sources, both those which are avoidable by careful construction and use and those which are inherent in the design of the instrument, these several sources of error will be taken up and analyzed separately.

(1) The first cause of errors in the determination of forces and moments, and one of the most important, is the deflection of the vertical portion of the balance under the force acting on the model. In measuring forces, since the portion of the balance below the main pivot is subjected to no transverse forces except the minute ones due to the resistance of the oil in the dash-pot, all of the deflection takes place between the pivot and the model. In the case of a balance in which, as in that at Langley Field, the weighing arms are trussed by tie-rods, virtually all the deflection when the lower pivot is not engaged occurs above the point of attachment of these tie-rods. When pitching moments are being taken, however, the lower pivot is thrown into position to keep the balance axis vertical, and the deflection in the portion of the balance between the two pivots may be of considerable magnitude.

The error which deflection causes in the measurement of forces is due to the movement of the model and the upper portion of the balance with respect to the vertical through the main pivot. This movement changes the moment of the weight of the model about the pivot when the weighing arms are in the central position, and so changes the amount of weight required to keep the balance in equilibrium. Since the deflection is proportional to the load applied, and the error for a given weight of model is proportional to the deflection, the percentage error is quite independent of the load applied. It is necessary, then, in order to secure a definite percentage accuracy, that the balance and spindle be just as stiff and heavy for tests at 10 meters per second as for those at 50. Furthermore, since the balance, chuck, and spindle are circular in cross section at all points, the percentage error in lift due to deflection will be the same as that in respect of drag, except for the portion caused by the deflection of the model itself. The error here will be greater in lift than in drag at small angles of attack, as the model aerofoil bends much more readily about an axis parallel to the chord than about one perpendicular to the chord. At angles of 4° or more the resultant force is nearly perpendicular to the chord, and the difference just spoken of between lift and drag therefore does not appear. By far the largest part of the deflection error arises from the bending of the spindle which supports the model and which must have a small outside diameter in order that the interference with the flow of air may not be excessive. The deflection error always exists and is perfectly determinate in magnitude and sign, so that it can be computed or determined experimentally and correction made for it. This is sometimes done, but it is preferable to make the balance stiff enough so that no correction will be required.

In the quantitative discussion of deflection effects the English system of weights and measures will be used, as the constants of materials will be much more familiar in that system than in the metric to most readers. The deflection of the balance at Langley Field, from the pivot to the upper end of the trumpet top, a total length of 33 inches, is 0.00071 inch under a load of 1 pound, applied at the center of the tunnel, and the slope at the upper end of the trumpet top when the balance axis is vertical is 0.000099 per pound of load. With an aerofoil 60 by 10 cm. (approx-

mately 24 by 4 inches), supported at its lower end by a spindle tapering in diameter from $\frac{9}{16}$ inch at the point of contact with the wing to 1 inch at the point where it enters the chuck, the total deflection, neglecting the bending of the aerofoil itself, is 0.0076 inch per pound. The deflection of an aluminum aerofoil, in respect of lift, may augment this by 0.0204 inch per pound, making a total of 0.0280 inch per pound with an aluminum model. The corresponding figure for a steel aerofoil is 0.0144 inch. There is also likely to be some permanent yielding at the joint between an aluminum aerofoil and its spindle, due to the softness of the aluminum. The remedy is to drill and cut a thread deeper into the model or to mortise the spindle into the wing and rivet them together.

The weight of an aluminum aerofoil of average thickness and 24 by 4 inches in plan form is from $1\frac{1}{2}$ to 2 pounds, and its center of gravity has just been shown to move 0.0280 inch under a lateral load of 1 pound perpendicular to the chord. (This is actually the distance that a point fixed in the plane of the chords of the aerofoil and halfway between the tips moves. The displacement of the center of gravity is a little greater, due to the bending of the wing, but the difference between the distance as just computed and that actually traveled is not very important.) The weight of the steel spindle is 1.26 pounds, and the distance moved by its center of gravity under a load of 1 pound is approximately 0.0015 inch. The total moment about the pivot due to these displacements with a 2-pound model is

$$(2 \times 0.0280) + (1.26 \times 0.0015) = 0.0560 + 0.0019 = 0.0579 \text{ lbs. ins.}$$

This is equal to the moment given by a lateral force of 0.00107 pound applied 54 inches above the pivot. The error in the measurement of the forces on a model aerofoil caused by the deflections of balance, spindle, and model is then about 0.11 per cent. If the model aerofoil is made of steel instead of aluminum its weight is about 5 pounds, and the possible error in lift measurements is increased to 0.14 per cent despite the greater stiffness of the steel. It is evident that, both to keep down the deflection error and to reduce the weight resting on the pivot, aluminum is the material par excellence for models, and steel should only be used when it is desired to grind a standard wing to form with the highest possible degree of accuracy, or when the model is to be tested at so high a wind speed that an aluminum model would be likely to be stressed beyond its elastic limit. Even where accuracy of construction is the dominant consideration aluminum is but little inferior to steel, although the aluminum is, of course, much more liable to be bent or otherwise injured by careless handling. Brass, sometimes used for models in the past, is thrown quite out of consideration by its high density and low modulus of elasticity and stiffness.

The deflection of a complete model is somewhat less than that of a single wing under the same load, as the parts of the model tend to reenforce each other, even where the wing bracing is omitted. For a model weighing 10 pounds, a figure which should seldom if ever be exceeded with models of the size used in the Langley Field tunnel the error due to deflection should always be less than one-half per cent. This is large enough, so that some allowance for it would be required, but 10-pound models are fortunately the exception rather than the rule, and deflection effects can usually be ignored in the measurement of forces with this balance, although they have proved a very important factor with some balances of similar type.

The effect of deflection on the determination of pitching moments, and so of centers of pressure and vector diagrams, may become important with aerofoils of little stiffness tested at high speeds. Since moments are measured with reference to a vertical axis passing through the pivots, any deflection of the model support will shift the position of this axis in the model. This will result in the moments actually being measured with reference to a different axis from that experimentally determined before or after the run. Since all parts of the balance itself are circular in section the line of resultant deflection will be parallel to the line of action of the resultant force on the model. A shifting of the axis of moments parallel to the line of action of the resultant force manifestly does not affect the magnitudes of the moments, and the deflections of the balance proper can therefore have no effect on the determination of the location of the vectors. The model, however, does not, by any means possess radial symmetry and the di-

rection of its deflection is almost constant and independent of the direction of the force acting, since only the component of that force which is perpendicular to the chord of the aerofoil is effective in bending the model. Strictly speaking, the component of interest is that perpendicular to the principal axis of the section, not to the chord, but the two are nearly coincident. The principal axis have been determined for a number of sections, and the angle between the principal axes and the system of axes parallel and perpendicular to the chord was not, in any case, more than $1\frac{1}{2}^\circ$. The deflection of the average aluminum model due to its own bending alone has been shown to be 0.0204 inch per pound, or 0.204 inch under a load of 10 pounds, which is the maximum that most aerofoils of cast aluminum alloy will safely sustain. The deflection under unit load is only one-third as much for a steel model as for an aluminum one, but the maximum load liable to be sustained is about four times as great, so that the maximum total deflection for a steel model is in the neighborhood of 0.27 inch. The angle between the vector of resultant force and the principal axis of maximum moment of inertia is never much more than 9° at any angle of incidence from 0° to 18° . The error in determination of the center of pressure or vector position would therefore not exceed two-thirteenths of the deflection of the model, and the largest error in that determination for an aluminum aerofoil subjected to a force of 10 pounds would not exceed 0.031 inch, or 0.8 per cent of the chord. Over the most important range of angles, that in which most normal flying is done, from 1° to 8° , the error would be less than half as large as this. In general, it may be said that it is necessary to make some allowance for the effect of model deflection on pitching moment when the test is run at a wind speed of 30 meters per second (approximately 66 miles per hour) or more with an aluminum, and at a speed of 50 meters per second or more in the case of a steel, model. Speeds above the latter figure are never reached in the course of ordinary testing, and, indeed, the former is seldom exceeded.

Although it has no direct effect on the accuracy of the measurements the deflection of the lower tube is of some interest as affecting the displacement of the model with respect to the fair-water when moments are being measured and as contributing another possible source of flexural vibration. The effect of this deflection is to increase the displacement of the model under a 20-pound load by 0.161 inch.

(2) The deflection of the weighing arms also has some effect, arising from two different sources, on the accuracy of the results. In the first place, since deflection throws the point of support of the weights below the horizontal plane through the main pivot when the balance is in equilibrium, the sensitivity is affected, as has been shown in another section of the report. Secondly, the instrument is balanced up initially with the cross hairs in line when the two pivots are engaged and with little or no weight on the ends of the weighing arms. It may be assumed that the weight on the ends of the arms when balancing up is just sufficient to balance the counterweights and other eccentrically placed parts, so that the center of gravity of the whole assembly is directly below the main pivot. If more weight be added, deflecting the arm, the cross hairs will no longer be in line, and if the balance axis is tilted to bring the tip of the arm back to the central position the center of gravity will be moved to one side and will exert a restoring moment when the only moments supposed to be acting are those due to the force on the model and the weights added on the weighing arms to balance that force. Obviously the error from this source is greatest when the center of gravity of the balance itself is farthest below the pivot. If the length of the weighing arm, from the pivot to the point of application of the weights, is l and its deflection is δ , the angle of rotation from the initial position of the balance in order to bring the cross-hairs into alignment after deflection is

$$\theta = \frac{\delta}{l}$$

The righting moment due to the weight of the balance being displaced with respect to the pivot is then $K \times \theta$, or $K \times \frac{\delta}{l}$, where K is the product of the weight of the balance and model by the vertical distance from the pivot to the center of gravity of the balance and model combined. It

is shown elsewhere that 47,000 gm. cm., or 40.7 pounds inches, is a fair value for K in a balance the size of the one at Langley Field. If the arms were made, as in the original N. P. L. balance, of solid steel rods $\frac{1}{8}$ inch in diameter acting as cantilevers, the deflection in a length of 23 inches under a load of 40 pounds (corresponding to 20 pounds on the model) would be 0.140 inch. With the value of K given above, this would cause the weight applied to be in error by 0.25 pound, or 0.6 per cent of the total amount. The error due to the deflection of the weighing arms, like that due to the deflection of the balance head, is directly proportional to the force acting, and the percentage error is therefore independent of the force.

On the Langley Field balance the weighing arms are steel tubes, 1 inch in diameter outside and with a wall thickness of 0.06 inch. They are trussed by tie-rods $\frac{3}{16}$ inch in diameter, and making an angle of $12^\circ.5$ with the direction of the arm itself. The deflection of one of these arms under an end load of 40 pounds is 0.027 inch, due chiefly to the elongation of the tie-rod, if the rod and arm are perfectly straight. It is almost impossible to keep the tie-rod absolutely straight, especially where one end is screwed directly into a lug, and the actual deflection is liable to be a little greater than that computed. The deflection with tubular trussed weighing arms is, however, always much less than with solid cantilever arms of the same outside diameter, and the trussed arms also have a great advantage in respect of weight, as has been shown

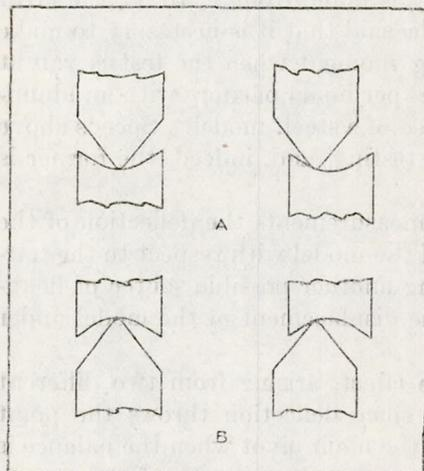

FIGURE 11.

Balances may be constructed with the pivot pointing either upward or downward. In the first case the pivot is carried by the balance support; in the second case by the balance itself. Enlarged views of the two dispositions, both in the normal position and with the balance slipped slightly to one side, are shown in Fig. 11. The difference between the points of contact in the original and displaced positions is indicated in the drawings. The first type of contact considered will be that in which, as in the drawings, the pivot and socket in the neighborhood of the point of contact are each a segment of a sphere. It will be noted that when the pivot is pointing upward the point of contact moves in the balance by a distance nearly equal to the distance which the balance slips (that is, the point of contact remains very close to its original position on the support), but that, in the converse case, the movement of the point of contact in the balance is very slight. If the downward-pointing pivot rested on a flat surface the point of contact would not move at all in the balance and there would be no error due to slippage of the balance with respect to the support, but this disposition is obviously impractical, as the balance would quickly slide, impelled by the horizontal force acting on the model, into a position pressed up against the side of the socket, where it could not rock at all.

already. The error arising from the deflection of the weighing arms, if they are properly designed and if the sensitivity is adjusted with reasonable care before starting a test, may be disregarded.

(3) A very troublesome source of error, and one which is sometimes difficult to eliminate, is the sliding of the main pivot in its socket. If the pivot moves, the point of contact between the two surfaces will, in general, be shifted both on the pivot and in the socket. This shifting changes the moment of the weight of the balance itself about the pivot, and so changes the amount of weight which must be added to secure initial equilibrium with no force on the model. If the shifting of the pivot occurs during a run, between the times of taking the "zero reading" and that with the wind on, the change in the amount of weight required for balancing will appear as an error in the result of the measurement.

It is evident from the preceding that the pivot should be carried by the moving portion of the balance, and that it should point downward. This has another advantage in that the socket, being concave upward, can be kept filled with a thin oil to reduce the sliding friction between pivot and socket. The formula for the displacement of the point of contact in the moving portion of the balance is:

$$\xi = \frac{xR_2}{R_1 - R_2}$$

where x is the distance which the balance slides, parallel to itself, with reference to an axis fixed in space, and R_1 and R_2 are the radii of curvature of the socket and pivot, respectively. It appears from this that it would be advantageous, aside from all questions of friction, to make the pivot as sharp as possible and to employ a large radius of curvature in the socket. The first deduction is perfectly correct, but the radius of curvature of the socket is of minor importance, so far as the effect of slippage of the pivot is concerned, since it is the slope of the tangent plane at the point of contact, and not the distance moved, which limits the slip of the pivot. The ratio between the vertical and horizontal forces acting on the balance ranges between 0 and $\frac{1}{2}$ as limits, but seldom exceeds 0.35. (The value $\frac{1}{2}$ could not be reached unless the balance itself were weightless.) Taking 0 and 0.35 as the limits, it appears that the inclination to the horizontal of the surface on which the balance would rest in equilibrium, if there were no friction, lies between 0° and 19° . The pivot would rest in the bottom of the socket while the "zero readings" were being taken, and would slide up onto the inclined portion of the socket when a horizontal pressure was exerted against the model. If the total weight of the balance and model (not including the weights required to balance the force on the model) is W and the horizontal force acting is L , the angle of inclination of the common tangent to the pivot and socket for equilibrium under frictionless conditions is:

$$\phi = \tan^{-1} \frac{L}{W + 2L}$$

assuming the distance from the pivot to the model to be twice the distance from the pivot to the point of attachment of the weights. The point of contact is then shifted in the balance by the amount

$$\xi = R_2 \times \sin \phi$$

and the change in moment of the moving weight about the pivot is:

$$\Delta M = R_2 \times W \times \sin \phi$$

The error in force measurement caused by this change of moment is

$$\Delta F = \frac{R_2 \times W \times \sin \phi}{h}$$

where h is the distance from the pivot to the plane of symmetry of the model. Since ϕ is always a small angle $\sin \phi$ and $\tan \phi$ may be considered equal. The error is then approximately

$$\Delta F = \frac{R_2}{h} \times \frac{L \times W}{W + 2L}$$

In the Langley Field balance W is 28,000 gms., h is 137 cm., and the maximum value of L is about 18,000 gms. Under these conditions the possible error due to slipping of the pivot if there were no friction would be $5.75 R_2$ gms., where R_2 is given in mm. The maximum percentage of error occurs when L is very small, and is, for the case just cited, $0.072 R_2$ per cent. With the usual values of R_2 this is not important.

These figures have been based on the neglect of sliding friction, a factor which generally can not by any means be disregarded. If the coefficient of friction between the pivot and its socket is 0.2 the angle of inclination of the surfaces at the point of contact may be more than 5° when there is no force acting on the model. Using the figures just given, it appears that shifting of the pivot may cause a constant error of 1.2 R_2 gms.

If the socket were truly conical, there could not be any sliding of the pivot, but the sensitivity of the balance would be decreased by friction, as the slightly rounded pivot would make contact with its socket all around the circumference of a circle, and the relative motion between the two for any rocking of the balance would be sliding instead of pure rolling.

(4) A factor whose importance is frequently underestimated is the canting of the model due to inaccurate alignment of the spindle. When the spindle is screwed into an aerofoil it is very difficult to get the tapped hole exactly parallel to the leading edge, and the result is that the model usually has a distinct tilt, either in yaw or in roll, from the desired position. If the tilt is in respect of yaw the plane of symmetry of the model is no longer parallel to the wind direction. In this general case there are six forces and moments to deal with in place of the three which exist when the model is placed exactly correct. To illustrate the importance of the various factors the effect of each of the six quantities will be followed through in turn for an angle of yaw of 2° , this being a value which should not be exceeded if reasonable care is taken in fitting the spindle to the model. The forces and moments on the Clark tractor biplane model will be used in the illustrative example, these data having been obtained at the wind tunnel of the Massachusetts Institute of Technology.¹

Denoting the forces by X , Y , Z , and the moments by L , M , and N in the usual manner, the figures with the model, of 48 cm. span placed symmetrically are, for a wind speed of 15 meters per second and various angles of attack:

Angle of attack.	0°	6°	12°
X (gms.).....	58.0	74.4	123.0
Y (gms.).....	0.0	0.0	0.0
Z (gms.).....	207.0	615.0	899.0
L (gm. cm.).....	0.0	0.0	0.0
M (gm. cm.).....	0.0	0.0	0.0
N (gm. cm.).....	0.0	0.0	0.0

The spindle is assumed to be located as to intersect the vector of resultant force, so that the pitching moment, as well as the other two, is zero when the model is in the position of symmetry.

At an angle of yaw of 2° the forces and movements are:

Angle of attack.	0°	6°	12°
X (gms.).....	59.5	75.4	123.0
Y (gms.).....	- 5.4	- 4.0	- 5.2
Z (gms.).....	205.0	613.0	894.0
L (gm. cm.).....	+ 71.5	+161.0	+114.0
M (gm. cm.).....	+ 3.8	- 22.4	0.0
N (gm. cm.).....	- 18.8	- 19.0	- 31.0

The total moment about a horizontal axis passing through the main pivot and perpendicular to the axis of the tunnel is

$$M_D = Xh \cos \psi - Yh \sin \psi + N$$

where ψ is the angle of yaw and h is, as before, the height from pivot to model. In the Massachusetts Institute of Technology balance h is 91.4 cm.

¹ Dynamical Stability of Aeroplanes, by J. C. Hunsaker: Smithsonian Misc. Coll., vol. 62, No. 5; Washington, 1916.

The equivalent force balanced by hanging weights on the drag arm is equal to M_d divided by h , or

$$F_d = X \cos \psi - Y \sin \psi + \frac{N}{h}$$

Angle of attack.	0°	6°	12°
X	58.0	74.4	123.0
F ($\psi = +2^\circ$).....	59.5	75.3	123.0
F ($\psi = -2^\circ$).....	59.9	75.6	124.0

It appears that an angle of yaw of -2° may lead to errors of from 1 per cent to 3 per cent in the measurement of the drag, and that, in order to keep the error within the desired maximum of $\frac{1}{4}$ per cent, the angle of yaw must not exceed 0.2° . This ideal is perfectly possible to realize mechanically, but the spindle itself deflects at small angles so that the slope at its tip in the plane of the wing chords is slightly more than 0.2° when tests are run at 50 meters per second.

The error in lift measurement due to the model being set up at angle of yaw must be found in the same way. The total moment about an axis passing through the balance pivot and parallel to the tunnel axis is

$$M_L = Zh + M \sin \psi - L \cos \psi$$

and the equivalent force is

$$F = Z + \frac{M \sin \psi - L \cos \psi}{h}$$

The true and apparent values of Z may be tabulated as for X .

Angle of attack.	0°	6°	12°
Z	207	615	899
F_L ($\psi = +2^\circ$).....	204	611	893
F_L ($\psi = -2^\circ$).....	204	611	893

The error in lift is obviously much smaller than that in drag, and it is the accuracy desired in the latter measurement that controls the degree of precision necessary in alignment.

To complete the analysis the effect of yaw on the moments about a vertical axis must be discussed. The equation for the total moment is

$$M_v = M \cos \psi + L \sin \psi$$

Angle of attack.	0°	6°	12°
M	0.0	0.0	0.0
M_v ($\psi = \pm 2^\circ$).....	+6.3	-16.7	+4.0

These differences between the true and the apparent moments correspond to errors of 0.030, 0.027, and 0.004 cm., respectively, in the location of the vector of resultant force. These errors are negligible, the largest being less than $\frac{1}{2}$ per cent of the wing chord.

In short, then, it appears that the accurate alignment of the model in yaw is of importance primarily as regards drag and that its importance there is considerable. If the data for a single aerofoil, instead of for a complete model, are taken the importance of accurate alignment is lessened, as Y and N , which cause most of the difficulty, both arise largely from the body and tail surfaces. For bodies and other streamline forms, on the other hand, the relative importance of accurate alignment is greater than for models of complete airplanes.

The analysis of the modifications in the measurements when the model is tilted in roll instead of in yaw is much simpler, since the axis of the tunnel remains parallel to the plane of symmetry of the model, which merely rotates about it. There are, therefore, no rolling or

yawing moments or cross wind forces to be considered. The equations for moments about the three mutually perpendicular axes when the model is rolled through an angle ϕ may be written

$$\begin{aligned}M_L &= Zh \cos \phi \\M_D &= Xh + M \sin \phi \\M_V &= M \cos \phi\end{aligned}$$

The equivalent forces are

$$\begin{aligned}F_L &= Z \cos \phi \\F_D &= X + \frac{M \sin \phi}{h}\end{aligned}$$

The errors in lift and pitching moment are negligible for all angles of roll up to 4° . The error in drag is also very small unless M is large (i. e., unless the spindle is attached far from the line of action of the resultant force). In order that a roll of 1° may not cause an error of more than $\frac{1}{4}$ per cent in the drag when the lift/drag ratio is 16, the ratio $\frac{\epsilon}{h}$ where ϵ is the shortest distance from the axis of support of the model to the line of action of the resultant force, must not exceed 0.009. It is usually practicable to keep $\frac{\epsilon}{h}$ below this figure, at least at those angles of incidence for which the efficiency is a maximum. Since h is 137 cm. on the Langley Field balance ϵ should be kept below 1.23 cm. As has been seen in examining sensitivity, there are other cogent reasons for keeping ϵ as small as possible. The tendency of the deflection of the spindle is to set the model at a positive angle of yaw and negative angle of roll. The first of these increases the apparent drag, while the second diminishes it if, as is almost always the case, the spindle is attached to the rear of the line of action of the force on the model. The two therefore tend to counterbalance each other, and it should be possible, by the exercise of proper care in attaching the spindle to align it correctly and keep ϵ as low as possible, to insure that the resultant error due to canting of the model will not exceed $\frac{1}{4}$ per cent. The slipshod methods frequently used for mounting aerofoils on their spindles must not be tolerated.

(5) If the balance axis is not exactly vertical when pitching moments are being observed the weight of the balance itself, assuming that its center of gravity does not lie exactly on the line connecting the two pivots, and the weight placed on the scale pans to reduce the lateral pressure on the lower pivot have moments about the axis of rotation of the balance. The moments due to the attached weights are much larger than that due to the weight of the balance itself, as the length of the arm from which the weights are suspended is far greater than the distance from the axis to the center of gravity of the balance.

The balance axis will be assumed to be inclined to the vertical and to lie in such a plane that the lift arm is horizontal. This is the worst case possible, since the lift arm carries the maximum load and a weight is always most effective in producing rotation about an inclined axis when a perpendicular line from the weight to the inclined axis is perpendicular to the vertical plane in which the inclined axis lies.

If the balance axis is inclined from the vertical by a small angle θ the moment about that axis of the weight on the lift arm is $w_e \times l \times \theta$. Taking as a maximum figure for the Langley Field balance 20 kg. on the lift arm, since l is 68.5 cm. the moment due to the addition of this weight is 1,370,000 θ gm. cm. If the criterion of desired accuracy in the measurement of moments be taken to be the determination of the location of the vector of resultant force within 0.5 mm., the error in the pitching moment under the conditions just specified must not exceed 500 gm. cm. θ must therefore be less than 0.000365 radian or $0^\circ 02' 09$. This degree of accuracy of alignment can be secured without difficulty by making successive trials, hanging weights on the lift and drag arms (with no model in place and no wind) and taking readings of the moment about the axis through the two pivots. The scale reading under these conditions should manifestly be unaffected by the amount of weight hung on the arms.

(6) If the model is not properly lined up with the wind direction before starting a test, or, what amounts to the same thing, if the reference line used for lining up all models is not accurately located, the only effect is to produce a constant error in angle of attack, and so to shift the characteristic curves resulting from the test bodily to the right or left, according to the direction of the initial error. The maximum and minimum values of coefficients and ratios are entirely unaffected, as is the curve of lift coefficient against L/D . Although the accurate determination of angle of attack is not of much interest in routine commercial testing (if a designer can obtain a curve of horsepower required against airspeed for his machine, he is ordinarily quite satisfied without knowing the exact angle of attack corresponding to a given speed), it is of great importance in such work as the determination of correction factors for aspect ratio, etc., where a slight uncertainty as to alignment may make it quite impossible to draw any consistent conclusions from a set of tests. Provision should therefore be made for lining up wings within 0.05° whenever it becomes necessary to do so. This degree of accuracy can be secured, with great care in sighting and with a batten carefully picked for its straightness, by the common method of binding a batten to the face of the wing and sighting it against a line painted on the floor of the tunnel, but it is more accurate and easier for the observer to use some optical method.

(7) A much more important source of error than the misalignment of the model is the misalignment of the balance with respect to the wind. In order that the lift and drag, acting perpendicular and parallel to the wind, may be measured directly the arms of the balance must themselves be set exactly perpendicular and parallel to the wind direction. If they are not, the force acting on the model will be resolved into components along some other axes than those desired and a large error may be introduced in at least one of the components.

If the components of force perpendicular and parallel to the wind direction be represented by L and D , respectively, and if the balance be supposed to rotate as a whole about a vertical axis so that the drag arm makes the angle θ with the wind direction, θ being taken as positive when the lift arm moves towards the original position of the drag arm, the lift and drag arms remaining parallel to each other, the components of the resultant force along the two arms will be

$$\begin{aligned} L \cos \theta + D \sin \theta &\text{ for the lift arm, and} \\ D \cos \theta - L \sin \theta &\text{ for the drag arm.} \end{aligned}$$

Multiplying and dividing by appropriate factors, these become

$$\begin{aligned} F_L &= L \cos \theta \left(1 + \frac{D}{L} \tan \theta\right) \\ F_D &= D \cos \theta \left(1 - \frac{L}{D} \tan \theta\right) \end{aligned}$$

Even with the utmost carelessness in lining up the balance, θ should never exceed 1° . Since the ratio of lift to drag is at least three for all objects on which accurate measurements of the lift are desired, the error in L due to misalignment should not, under any conditions, be greater than 0.6 per cent. This is an error by no means negligible, but still not very important, inasmuch as it reaches its maximum only when the L/D is low (e. g., in the neighborhood of the burble point). For wings and models of complete airplanes at angles in the region of high efficiency the error in lift measurements arising from a misalignment of the arms by 1° is well within $\frac{1}{4}$ per cent.

The error in drag is much more serious, particularly as it is largest at the point of maximum efficiency, just where accurate measurements are most desired. For a good wing, having a value of L/D of 18, the error in drag measurement when θ is 1° is more than 30 per cent. If the drag is to be measured accurately within one-fourth per cent, the balance must be lined up with the drag arm parallel to the wind to within 0.008° . A similar relative accuracy of measurement of the drag with models of complete airplanes, having a maximum L/D of 8, requires an alignment correct within 0.018° . Such accuracy as this is hardly to be expected, and errors in alignment of the balance arms are the largest single cause of error in the determination of the L/D at small angles; but a surprisingly close alignment (well within 0.05°) can be secured and maintained by careful setting up of the instrument and constant checking.

The method originally used in this country for aligning the balance arms with respect to the wing in balances of the N. P. L. type required the use of a flat plate. This was tested at several positive and negative angles. If the plate, the balance arms, and the wind direction were all properly disposed with respect to each other, the lifts for equal positive and negative angles should be equal in magnitude but opposite in sign, and the drags should be equal. If the first of these conditions was fulfilled but the second was not, it indicated that the zero angle of attack had been properly located, but that misalignment of the balance arms existed. The flat-plate method was unsatisfactory chiefly because of the low efficiency of such a surface. It has just been shown that the error in drag measurements caused by misalignment of the arms is proportional to the L/D ratio. When the L/D ratio is small, therefore, as it always is in a flat plate, it is exceedingly difficult to detect small errors in alignment, errors which may nevertheless have an important effect on the measurement of drag in a high-efficiency wing. Furthermore, it is difficult to secure a plate which is and will remain truly flat. Inaccuracies of surface too small to be detected by any ordinary means of measurement may cause a distinct difference between the lift-drag ratios at equal positive and negative angles. This difficulty was overcome in part by repeating the work with the plate turned through 180° about a vertical axis.

The method now adopted and first introduced by the N. P. L. several years ago substitutes a model aerofoil for the flat plate. The aerofoil is drilled and tapped for a spindle at each end, so that it may be supported in an inverted as well as in the normal position. Tests are then run in both positions and the L/D curves compared. Since the lift in the inverted position must be balanced by the removal of weight from the lift arm, it is usually necessary, in order that angles up to 6° or 8° may be taken in this condition, that more weight be added to the lift counterweight, thereby increasing the zero reading. This method permits of much more accurate alignment than does the flat-plate method. Its only important drawback is that the model has to be taken down and set up again between tests; but, as already pointed out, the chords for zero angle of attack in the two positions can be set parallel within 0.05 by sighting along a batten, if care is exercised. The disadvantage is therefore not a serious one.

The use of an aerofoil in normal and inverted positions for checking up the alignment has another advantage in that it points the way to eliminating the effect of spin in the air-stream. The air drawn into the propeller has a tendency to follow a helical path of very large pitch-radius ratio, so that the direction of the wind near the top of the tunnel is slightly different from that near the bottom. If the direction of motion changes uniformly from top to bottom of the tunnel, the force acting on a wing would be almost identical with that which would act if there were no spin of the wind and if the direction of its motion were everywhere the same as that which actually prevails at the center of the span of the aerofoil. The readings of the balance in the two cases, however, would not be the same, since the moment arm about the pivot is different for different elements of the model. For example, consider two elements of equal area and at equal distances from the center of the span. The forces on the two elements will then be $F + \Delta F$ and $F - \Delta F$, where F is the force acting on an element of the same size located at mid section, and the moment arms about the pivot will be $h + \Delta h$ and $h - \Delta h$. The moments for the two will then be

$$(F + \Delta F)(h + \Delta h) \text{ and } (F - \Delta F)(h - \Delta h).$$

The mean of the forces on the two elements is, as already noted, equal to F , the force which would exist everywhere if there were no spin. The mean of the moments is

$$\frac{(F + \Delta F)(h + \Delta h) + (F - \Delta F)(h - \Delta h)}{2} = (F \times h) + (\Delta F \times \Delta h)$$

and is therefore different from the moment of an equal area at the middle of the wing. If, however, the wing be aligned so that the lifts at corresponding angles are equal in the normal and inverted positions, the force read on the weighing arm is the true one, and the effect of spin is eliminated. When the wing is set at zero angle of attack after being lined up in this way, the

chord is not exactly parallel to the wind direction at mid span, but the readings of the weighing arms are identical with those which would be obtained if there were no spin in the wind and the chord were set parallel to the wind direction. The alignment found in this way varies slightly with the slope of the curves of lift and drag coefficients; and it also requires, for accuracy, that the form of the aerofoil section be exactly symmetrical from tip to tip. It is best, therefore, to carry through the work of alignment with two or three different models in succession and at several angles for each model. It is difficult to determine the maximum possible error due to misalignment in any specific case, but it is probably not over 1 per cent under the worst conditions when the balance is lined up carefully by this method.

(8) Closely allied to misalignment of the model with respect to the wind, in that the primary effect of both is to cause an error in the determination of the angle of incidence, is the torsion of the spindle. The total twist of the spindle is negligible when a straight spindle is used attached directly to the end of an aerofoil, since the torsional moment is then very small. For example, with a force of 20,000 gms. applied 1 cm. from the center of the spindle 23 cm. long and tapering in diameter from 25.4 mm. to 14.3 mm., like that used at Langley Field, the twist would be less than $0^{\circ}05$. There should never be any difficulty in keeping the spindle within 1 cm. of the center of pressure of the chord at the angle of maximum lift. In complete models, where it is not always possible to attach the spindle at the desired point, other parts of the model interfering, and where the point of application of the resultant force moves over a wider range than on a single aerofoil, this limit may sometimes be exceeded five or six times, so that the maximum twist may be $0^{\circ}3$ or a little more. This offers an additional reason for so locating the spindle as to keep the pitching moment as small as possible. Even $0^{\circ}3$, however, is ordinarily of slight importance except where accurate checks on two or more successive tests with some slight variation in the conditions are desired. As has already been pointed out, errors in angle of incidence up to about a quarter of a degree need cause no trouble in ordinary tests of complete models.

(9) The errors so far discussed have all arisen either from such inescapable phenomena as the deflection of the spindle or from improper mounting and alignment of the instrument or model. Those which remain to be discussed are due to errors in the construction of the balance itself, and may all be eliminated or reduced to insignificance by sufficiently accurate workmanship. The analysis of the sources of these errors and of the magnitudes which they may assume is of value primarily in that it indicates the accuracy necessary in the construction and assembly of the different parts.

The first, and perhaps the most obvious, of the points at which errors arise from failure to follow the designs with absolute exactitude is the length of the weighing arms. Obviously, if the weighing arms, or either one of them, are longer than they are intended to be, a weight suspended at the end of the long arm will balance a force at the center of the tunnel of more than half its own magnitude. The error in the reading will be directly proportional to the departure from the designed length. The permissible error in measurement has so far been taken as one-fourth per cent, but this will be reduced, in the case of the constant instrumental errors, to 0.1 per cent from each source. It is then permissible for the weighing arms to vary in length 0.1 per cent in either direction, or, in the Langley Field balance, 0.68 mm. A skilled man should not have the slightest difficulty in keeping the error down to one-fourth of this amount, and the accuracy sometimes sought for in this particular is really quite needless.

The same consideration of course applies with regard to the distance from the pivot to the center of the model, the permissible variation here being twice as great as that in the lengths of the weighing arms. If there is an error in this distance, or if there is a common error in the lengths of the two weighing arms, the leverage ratio can be restored to its proper value by modifying the distance which the spindle of the model is allowed to project from the chuck which attaches it to the balance.

(10) Another difficulty in connection with the weighing arms is their attachment exactly at right angles to each other. If they are not so attached errors will be caused in the measurement of the lift or drag, or both. The analytical work involved in the determination of these errors need not be followed through in detail in this report. If the arms are not at right angles the

alignment of the arms in order that the lifts and drags may both be the same at equal angles of an aerofoil in the normal and inverted positions will be different for every different aerofoil used and for every angle at which the tests for alignment are carried out. If, however, the alignment be supposed to have been carried out to satisfy the above condition as accurately as possible for a given model and angle of incidence there will still be an error in both lift and drag. The ratio of relative error between the two components is proportional to the ratio of the slope of the coefficient curves to the ordinates of those curves at the particular angle for which alignment was carried out. At all angles between that of minimum drag and that of maximum lift the error in both components is in the same direction, so that the error in L/D is less than that in either component alone. The balance readings are farthest astray from the true values in measuring the drag near the burble point, where a variation of 0.1° in the angle between the arms may lead to an error of nearly 2 per cent in the drag. This error falls off rapidly at angles smaller than the burble point, and the mistake made in the determination of the forces at angles between 0° and 8° , the range which is of most interest, would never be more than 0.03 per cent for a departure of 0.1° from a right angle between the arms. An accuracy of 0.3° in this angle is quite sufficient, if the balance is lined up in the manner here described, and if, in lining up, tests are made at several angles lying between 2° and 8° , the mean result being taken.

(11) If the strut and spring clamp which prevent the balance from rotating about a vertical axis are not horizontal the force which they exert against the arm will have a vertical component and will change the amount of weight which must be placed on the lift arm to secure equilibrium. If there is no pitching moment on the model the upward or downward component of the thrust of the strut against the arm will be exactly balanced by an equal and opposite component of the pull of the clamp. If there is a pitching moment, however, one of these two forces will be greater than the other and there will be an unbalanced vertical component. Assuming the moment arm of the resultant force with respect to the balance axis to be 4 cm., the moment is approximately $4L$, where L is the lift. This moment has to be balanced by the difference between the forces in the strut and spring clamp. If the vertical component of this difference is not to cause an error of more than 0.1 per cent in the measurement of L it must be less than $\frac{L \times h}{1,000}$, and the slope of the strut must not be greater than

$$\frac{L \times h}{1,000 \times 4L} = \frac{h}{4,000}$$

For the Langley Field balance this formula gives a limiting slope of 2° , a limit which would hardly be approached if any special precautions were taken.

(12) If the strut and clamp are horizontal, but are above or below the main pivot, the difference in the forces which they exert will have a moment tending to modify the reading of the drag arm. Since the distance between the pivot and the point at which the strut bears against the lift counterweight arm is, in the Langley Field balance, 30.5 cm., the difference in the two opposing forces is, for a moment of $4L$, $-0.13L$ gms. If ζ be the vertical distance from the horizontal plane through the main pivot to the point of contact of the strut the moment of the unbalanced force is $0.13L \times \zeta$, and its existence changes the reading of drag by

$$\frac{0.13L\zeta}{h}$$

This must be less than 0.1 per cent of D . Then

$$\frac{0.13L\zeta}{h} < \frac{D}{1,000}$$

$$\zeta < \frac{h}{130} \times \frac{D}{L}$$

In the case of the Langley Field balance, for an $\frac{L}{D}$ of 16, this leads to the conclusion that ζ must not exceed 0.07 cm.

(13) The strut and spring clamp bear in conical sockets opposed to each other. Both sockets are cut in a single piece of tool steel, and a great deal of care has been used in some cases to bring their apices as close together as possible without actually having them break through and meet. In some cases the bottoms of these sockets have been brought within 0.08 mm. of each other. Theoretically the two should be at a common point, and any separation between them introduces an error. The effect of a separation between the pivots of the strut and spring clamp will be analyzed first with regard to its effect on the measurements of lift and drag.

So long as the two sockets which carry the ends on the strut are on the same level the strut and spring clamp lie in the same plane, whatever the separation may be. If they are not on the same level, however, and it has just been shown that the line connecting them may slope 2° initially without serious effect, or if the balance rocks about the drag arm as an axis so that the end of the lift counterweight arm rises and falls, the two pieces no longer lie in the same plane, and the lines of action of their thrusts are no longer directly opposed. It will be supposed that there is no pitching moment acting, this being the condition during the taking of the zero readings, that the socket set in the end of the lift counterweight arm is initially as far above that set in the moment weighing arm as is safe (see (11)), and that the lift weighing arm is down as far as the stops in its cage permit it to go, so that the counterweight arm is up and the vertical distance between the ends of the strut is as large as it can ever be. The condition then existing is shown, much exaggerated and with the strut and spring clamp represented only by their center lines, in Figure 12. If F be the compression in the strut and also the force exerted by the spring clamp against its socket, the two being equal when there is no pitching moment, the moment about the lift arm due to the separation of the apices of the sockets is equal to the product of F by the distance between the lines of action of the two members at the point half-way between the apices of the sockets in the lift counterweight arm. Since $\Delta\alpha$ is negligible in comparison with α , this distance is $\epsilon \times \sin \alpha$, and the moment is

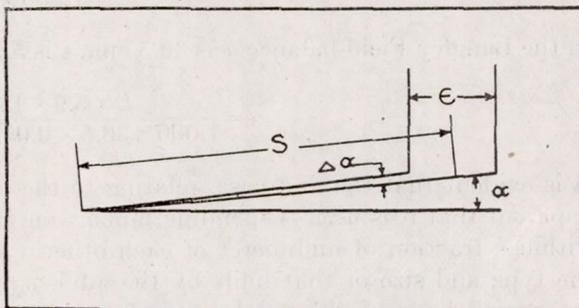

FIGURE 12.

$$F \times \epsilon \times \sin \alpha$$

The moment required to change the weight on the drag arm by 0.1 per cent is

$$\frac{D \times h}{1,000}$$

where h , as before, is the distance from the main pivot to the center of the model. Equating these two moments,

$$\frac{D \times h}{1,000} = F \times \epsilon \times \sin \alpha$$

$$\epsilon = \frac{D \times h}{1,000 \times F \times \sin \alpha}$$

In the particular case of the Langley Field balance h is 137 cm., the maximum likely to be attained by α is 3° , and the maximum of F is 8 kg., a maximum which would not be needed except at high wind speeds. Normally, the spring clamp would be adjusted for a smaller force unless the lift were at least 15 kg. D may then be assumed to be 1 kg. Substituting these figures in the formula above,

$$\epsilon = \frac{1,000 \times 137}{1,000 \times 8,000 \times 0.0523} = 0.328 \text{ cm.}$$

The separation between the apices of the pivot sockets also has an effect on the measurement of lift. The horizontal components of the forces in the strut and spring clamp are, as already noted, exactly equal and directly opposed, but the vertical components differ because of the slight difference in slope. This difference in slope is $\Delta\alpha$. Since α is small, the difference in vertical components is very nearly equal to $F \times \Delta\alpha$, and this is approximately

$$F \times \frac{\epsilon \times \sin \alpha}{s}$$

where s is the length of the strut.

If the socket at the end of the lift counterweight arm is at a distance (a) from the main pivot, the force corresponding to the moment about the main pivot resulting from this unbalanced vertical force is

$$F \times \frac{\epsilon \times \sin \alpha}{s} \times \frac{a}{h}$$

Equating this to $\frac{L}{1,000}$, the allowable error, it is seen that the limiting value for ϵ is:

$$\epsilon = \frac{L \times s \times h}{1,000 \times a \times \sin \alpha \times F}$$

In the Langley Field balance a is 30.5 cm., s is 5.9 cm., and F should never exceed $\frac{1}{2} L$. Then

$$\epsilon = \frac{L \times 5.9 \times 137}{1,000 \times 30.5 \times 0.0523 \times \frac{1}{2} L} = 1.01 \text{ cm.}$$

It is evident that the first case, relating to the error in drag, is the limiting one, and it is also apparent that it is useless spending much time in attempting to bring the apices of the sockets within a fraction of millimeter of each other. If they approach within 3 mm. in a balance of the type and size of that built by the advisory committee the errors resulting from the separation will be negligible, at least so far as lift and drag are concerned.

It has been assumed thus far that there is a separation between the apices of the sockets at one end only, and that the distance between the opposite ends of the strut and spring clamp is negligible. If this is not the case, there being an equal separation at both ends, the error in drag is not affected, while that in lift is doubled. The drag, however, still remains the limiting factor and the permissible separation therefore is not altered.

In measuring pitching moments the separation of the pivots causes an error similar to that arising in the drag from the same reason. If the sockets at the ends of the strut are on exactly the same level there is no error. In order that the error with the strut inclined 2° may not be over 250 gm. cm. when the lift is 10 kg. the separation of the pivots must be less than 0.365 cm. The drag, therefore, still furnishes the limiting case.

(14) The upper balance head is restrained laterally by a flange which projects down from the upper head into the lower one, and also by the tubular portion of the clamping ring. If the centers of these guiding rings are not exactly coincident with the line connecting the main and lower pivots, or if the surface of contact between the upper and lower parts of the balance is not perpendicular to the line joining the pivots, the center about which the model rotates when taking moments will not be correctly determined by the usual method. Since an error in the location of the center of rotation corresponds to an error of like absolute magnitude in the position of the vector or center of pressure in the model, the standards of accuracy which have been adopted require that this error shall not exceed 0.2 mm. In the Langley Field balance, the securing of this degree of accuracy exacts that the line connecting the pivots shall be perpendicular to the surface of separation between the heads within $0^\circ 009$. A movement of the lower pivot through 0.12 mm., due to bending of the lower tube, will throw the line connecting the pivots out by this angle, and it is therefore necessary that the lower tube be straightened and adjusted with great care, and that the perpendicularity of the line and surface defined above be checked frequently.

(15) Analogous to the error just discussed is that resulting from lateral play between the upper and lower heads of the balance, which changes the axis of rotation of the upper head relative to the line connecting the pivots. This lateral play, however, has another bad effect in that it moves the center of gravity of the upper head and so changes the amount of weight required on the weighing arms for the zero reading. If the upper head moves after the taking of the zero and before that with the wind on is secured there will be a resulting error

$$\epsilon \times \frac{W'}{h}$$

where ϵ is the lateral movement and W' is the weight of the upper head with all the parts directly attached to it. With a model of average weight, W' for the advisory committee's balance is about 6 kg. In order that the error in drag due to the slippage of the upper head may not be more than 0.5 gm. ϵ must not exceed 0.11 mm., and the clearance between the annular flange and the cylindrical portion of the lower head into which it fits should be kept below this figure.

ERRORS IN THE VERTICAL-FORCE MEASUREMENTS.

There are certain errors in this part of the balance which are obvious and are strictly analogous to those already considered for lift and drag measurements. An error in the length of the V. F. weighing arm, for example, has just the same effect as has a corresponding slip on the weighing arms for lift and drag. The knife-edge on the V. F. arm must be located with some care, as one arm of the beam (the one extending from the knife-edge through the balance wall to the center) is very short and only a small absolute error (about 0.1 mm.) is permissible. It is, however, easy to calibrate the V. F. arm with dead weight, and to adjust the knife-edges in accordance with the calibration.

The most serious fault to which the V. F. measurements are liable arises from the inclination to the horizontal of the link which is fastened to the wall of the balance and which carries the socket for the lower end of the long vertical rod. If the strut which runs vertically from that link to the inner end of the V. F. weighing arm is too long or too short the link will not be horizontal, and any force in it will have a vertical component causing an error in the measurement of the vertical force. The method of determining whether or not this error exists has been described elsewhere,¹ and it will suffice here to determine the magnitude of the error resulting from a given departure from the correct length of strut or, conversely, the accuracy with which the strut must be made to keep the error within a given tolerance.

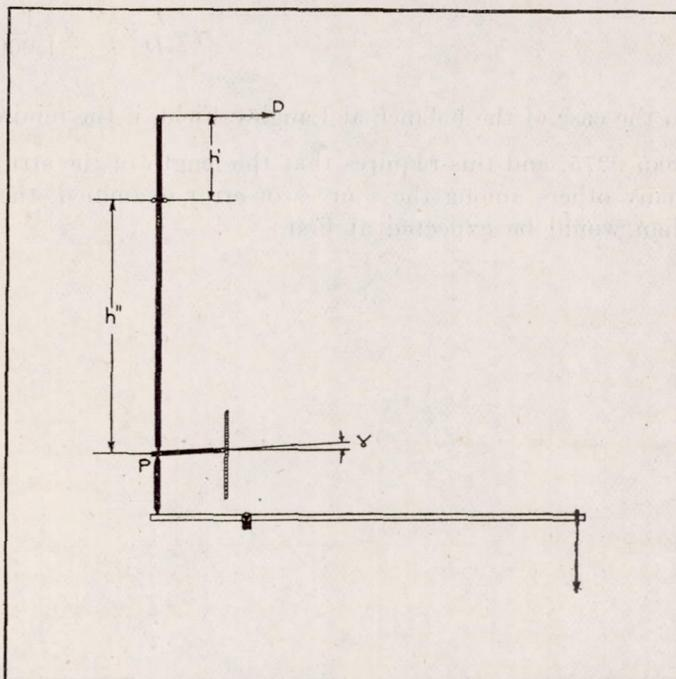

FIGURE 13.

¹ Report of British Advisory Committee for Aeronautics, 1912-13, p. 65: London.

The arrangement of the vertical force mechanism is shown diagrammatically in Fig. 13. Taking moments about the rollers at G , at which point the force against the rod must be exactly horizontal if the friction in the rollers be neglected, the force at P is seen to be

$$D \times \frac{h'}{h''}$$

The vertical component of this force is

$$D \times \frac{h'}{h''} \times \gamma$$

Since this is subtracted from the vertical force acting on the model it increases the apparent magnitude of the force. In order that the error in lift from this cause may not exceed 0.1 per cent the slope of the link must be less than

$$\gamma = \frac{L}{D} \times \frac{h''}{h'} \times \frac{1}{1,000}$$

In the case of the balance at Langley Field, if the minimum $\frac{L}{D}$ be taken as 5, γ must be less than 0.075, and this requires that the length of the strut be correct within 1 mm. Here, as in many others among the sources of error examined, the tolerance in dimensions is much larger than would be expected at first.

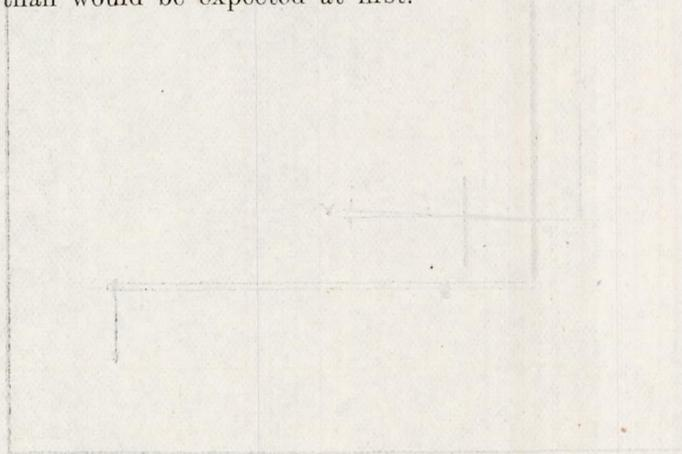

REPORT No. 72.

PART IV.

BRIEF NOTES ON BALANCES OF OTHER TYPES.

In discussing other types of balances, no attempt will be made to carry through any such exhaustive analysis of sources of error as has been developed for the N. P. L. instrument. The endeavor will be rather to show the reasons which led to the rejection of these other types in favor of the one finally adopted for construction and use at Langley Field.

(1) EIFFEL.

The principle of operation of the Eiffel balance is fully explained in his two books.¹ The essential parts of the instrument are shown diagrammatically in Fig. 14. Three readings are taken at each angle of incidence, determining the moments about axes *A*, *B*, and *C*. From these three values can be computed the magnitude and line of action of the resultant force on the model. In the actual instrument used at the Eiffel laboratories only two axes are used, *C* being omitted, and the moment about *A* is taken both with the model in the normal position and with the model inverted. The moments about *A* in the normal and inverted positions, respectively, will be denoted by M_A and M_A' , the moment about *B* by M_B .

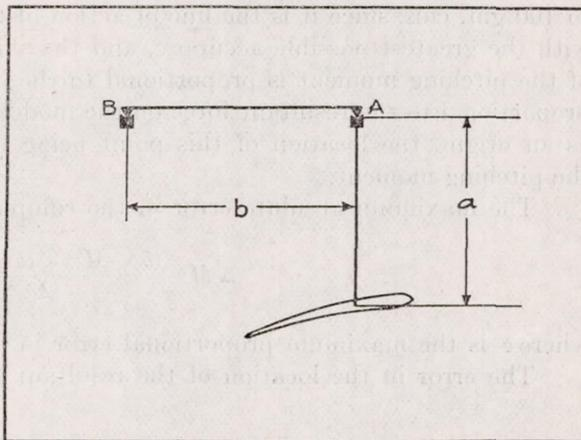

FIGURE 14.

If the force acting on the model be resolved into its components L and D , acting at the point shown in the diagram, and the pitching moment M , the equations for moments about the three axes can be written, assuming the model to be set up with the origin of its axes directly under *A*,

$$\begin{aligned} M_A &= (a \times D) - M \\ M_A' &= (a \times D) + M \\ M_B &= (a + c) \times D - (b \times L) - M \end{aligned}$$

Solving these equations, the formulae for L , D , and M can be secured.

$$\begin{aligned} L &= \frac{-M_B + (M_A' \times \frac{c}{2a}) + (M_A \times \frac{2a+c}{2a})}{b} \\ D &= \frac{M_A + M_A'}{2a} \\ M &= \frac{M_A' - M_A}{2} \end{aligned}$$

Ordinarily M_B is negative, M_A and M_A' positive. L and D are therefore obtained by summations, M by a subtraction.

¹ Recherches sur la Resistance de l'Air et l'Aviation, G. Eiffel, Paris, 1911. Nouvelles Recherches sur la Resistance de l'Air et l'Aviation, G. Eiffel, Paris, 1914.

Since the three moments are taken at different times the errors which appear in any two of the three due to variations in wind speed may be in the same or in opposite directions, and the worst of these conditions must be assumed in computing the maximum error which can enter into the computed quantities. The maximum error to be expected in any single measurement is approximately proportional to the magnitude of the measurement unless this is very small, as most of the error is caused by fluctuations in wind speed or by inaccuracies in its measurement. L and D are the results of summations, and the maximum percentage error in these forces therefore can not exceed the maximum percentage error in the factors from which they are determined. There should be no difficulty in keeping this below $\frac{1}{2}$ per cent. The only restriction that must be observed in order not to impair the accuracy of measurement of L and D is that the distance b must be large enough so that M_b will never become positive, or even approach very near to zero, under any ordinary conditions. This requirement will be satisfied if b is one-half as large as a . In Eiffel's balance b appears to be unnecessarily large, being approximately equal to a .

The errors arising in the computation of pitching moment are likely to be more serious, since that quantity is the difference of two moments. The error which is of interest here is absolute and not relative, a mistake of 10 gm. cm. in a given model being quite as serious if the total moment is 10,000 gm. cm. as it is if the spindle is so placed as to reduce the moment to 100 gm. cm., since it is the line of action of the resultant force which has to be determined with the greatest possible accuracy, and the shifting of this line by an error in determination of the pitching moment is proportional to the absolute magnitude of that error and inversely proportional to the resultant force on the model, but is entirely independent of the point taken as an origin, the location of this point being the chief factor determining the magnitude of the pitching moment.

The maximum absolute error in the computed pitching moment is

$$\Delta M = \frac{(\delta \times M_A) + (\delta \times M_A')}{2} = \delta \times a \times D$$

where δ is the maximum proportional error in a single measurement.

The error in the location of the resultant force is then nearly

$$\Delta X = \frac{\Delta M}{L} = \frac{\delta \times a}{D}$$

In the balance used at Eiffel's laboratory, a is approximately 10 times the chord of the models usually tested. Then, if l is the chord,

$$\Delta X = \frac{10\delta \times l}{D}$$

Taking L/D as 16 for wings, and δ as $1/200$, a possible error of a little more than 3 per cent of the chord in locating the center of pressure is indicated. For complete models, having a maximum L/D of 8, the error in locating the vector of resultant force may be as much as 6 per cent of the chord. For angles of attack other than those of maximum L/D the possible error is still greater. This large error is inherent in the Eiffel type of balance, and no modification of the dimensions can remove it. It can be somewhat reduced by reducing a , but steps in this direction are limited by the necessity of keeping the weighing beam and main supporting frame of the balance out of the moving air; a must, therefore, be at least half the diameter of the wind-stream.

This discussion has so far been based on the assumption that the moments about the various axes are not affected by any errors in the instrument itself. Actually, however, the spindle is quite as subject to deflection as in an N. P. L. balance. Since the bending moment

in the spindle at any particular point is not the same when the model is in the normal position as when it is held inverted at the same angle, the deflection will not be the same in the two cases. The moment about *A* in each position therefore includes a term proportional to the lift, and this term is different in the two positions. The failure to take account of the deflection of the model leads to errors in the computation of both forces and the pitching moment. The unequal deflections of the weighing arm when taking the two moments lead to an error of the same nature. The error in the drag from this cause may be as much as 3 per cent with a spindle of normal size, and the percentage error increases as the wind speed increases. If the spindle is enlarged to cut down the deflection it becomes a matter of great difficulty to allow for the increased spindle interference.

Furthermore, the drag of the model is not the same in the normal and inverted positions, because the effective drag of the spindle, due largely to interference, is quite different when it is attached on the upper surface of the wing from that when the spindle is mounted on the lower surface. This causes a further error in computing the pitching moment.

No detailed discussion of the errors arising in the Eiffel type of balance will be undertaken. Its chief disadvantages, in addition to the inherent inaccuracies already noted, are the time required for taking all the readings and working up the results therefrom, its great weight (the moving parts of the balance at Eiffel's laboratory weigh 50 kg., although it is never required to measure forces in excess of 10 kg.), and its lack of sensitivity, discussed in the next paragraph. Its only important advantages reside in the elimination of all pivots in favor of knife-edges and in the avoidance of serious errors due to failure to line the balance up to the wind accurately. If the axes about which moments are taken are not exactly perpendicular to the wind direction it is a matter of small import.

The sensitivity of the Eiffel balance is rather low, as the main portion of the instrument is supported on a pair of knife-edges, and these knife-edges are at the extreme top of the floating member. The center of gravity of this main beam is, judging from the drawings, about 35 cm. below the knife-edges, and there is consequently a large restoring moment due to the weight of the instrument when the beam is moved from the central position. The lack of sensitivity due to this cause could be balanced by placing the center of gravity of the weighing-beam well above the knife-edges on which it is supported, so that this member alone would be unstable, but this does not appear to have been done in the instrument used by Eiffel. No dash pot is incorporated, and it is therefore necessary to secure a good degree of stability of the beam in order that it may not make continuous violent oscillations between the stops.

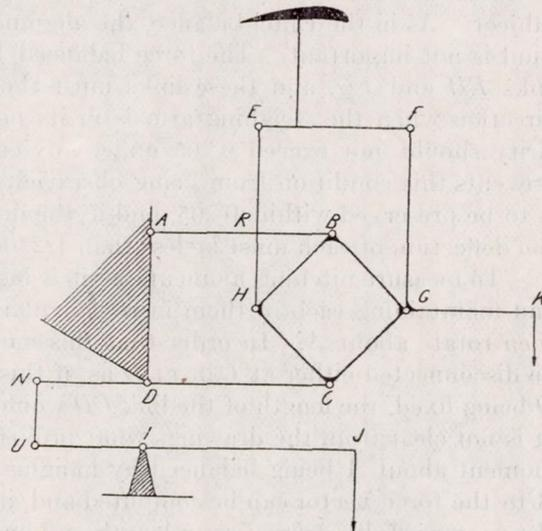

FIGURE 15.

(2) THE ST. CYR. BALANCE.

The balance used in the tunnel of the Institut Aerotechnique de St. Cyr is quite different from any of the older and better-known types, and it embodies many original and interesting features. The general arrangement is shown in Fig. 15. *ABCD* and *EFGH* are articulated parallelograms. *BGCH* is a rigid square frame.

The lift on the model causes the parallelograms *EFGH* and *BGCH* to rise, and *CDN* pivots about *D*. The upward movement of *C* is transmitted through the links *CDN* and *NU*, and raises the outer end of the weighing beam *UIJ*. Weight is added at *J* until this tendency to rise is balanced.

In measuring the drag the wing moves horizontally, GH acts as the fixed link, FGK pivots about G , and the drag is measured by weights at K .

Since AD is fixed in the frame of the balance, AD and BC always remain vertical, EF and GH horizontal. The model, therefore, moves parallel to itself, and the angle of attack never changes, nor do its slight movements cause it to assume any angle of roll or yaw. In this respect the St. Cyr balance has the advantage over the N. P. L. instrument.

The two measurements can not be entirely independent, as the weight attached at K exerts a direct downward force as well as a moment about G , and the lift is therefore greater than that read at J . Since the lift is the sum of two figures, the error is no greater than it would be if the lift were obtained by a single measurement.

Adjustable weights are carried on prolongations of EH and FG below the lower pivots, and these serve to adjust the position of the center of gravity and control the sensitivity with models of different weights.

All pivots are eliminated in this balance, knife-edges or ball-bearings being used at all joints. This, and the uniformly parallel motion of the model, are the greatest advantages of the St. Cyr type of balances. There is an objectionably large number of joints, 11 in all, as against the single pivot and the two universal joints provided by the strut and spring clamp in the N. P. L. instrument. The St. Cyr balance escapes some of the errors to which the simpler type is subject. As in the Eiffel balance, the alignment of the plane of the linkage with respect to the wind is not important. The force balanced by the weights at K is that perpendicular to the links EH and FG , and these links must therefore be very closely perpendicular to the wind direction when the weighing arm is in its neutral position. The departure from perpendicularity should not exceed $0^\circ.05$ under any conditions, and, since deflection either of FG or GK prevents this condition from being observed, those arms must be extremely stiff. If alignment is to be preserved within $0^\circ.05$, and if the deflection length ratio for FG and GK is the same, the deflection of each must be less than $1/2300$ of its length.

To measure pitching moments, a pin is inserted at R locking the two parallelograms together and maintaining each of them in rectangular form. The model and the parallelogram $EFGH$ then rotate about A . In order that this motion may be free it is necessary that the link CD be disconnected either at C or at D as, if this were not done, C would also rotate about A and, D being fixed, the length of the link CD would have to change in order to permit of any motion. It is not clear from the drawings what provision, if any, is made for such disarticulation. The moment about A being balanced by hanging weight on at K , the perpendicular distance from A to the force vector can be computed and, its slope being known from the force measurements, the vector is fully defined as to length and line of action.

It is thus necessary to make two runs with this balance, just as with the N. P. L. instrument, for a complete determination of the forces and moment acting on a symmetrical object. A number of other devices are incorporated in the balance for increasing the ease of reading and decreasing the work of computation involved. For example, there are a pair of small hydraulic dynamometers which permit the direct measurement of forces without the use of any weights at all. Special means are also provided for eliminating the zero reading on both weighing arms and for taking care of negative lifts, as well as for balancing the lift, due to the lowered static pressure inside the tunnel, on the flanged ring which dips into the oil seal.

(3) CURTISS.

The balance designed by Dr. A. F. Zahm for the 4-foot tunnel of the Curtiss Engineering Corporation is similar to the N. P. L. type in general, but differs from it in that the single pivot is replaced by two sets of knife-edges at right angles to each other. The lift and drag are then measured on separate runs. The knife-edges are carried at the extreme ends of the weighing arms, so that there is no possibility of one knife-edge being lifted from its socket by the transverse force on the model unless the lift is nearly equal to the total weight of the balance.

The use of two independent sets of knife-edges makes it possible, if desired, to secure different degrees of sensitivity in lift and drag. A much higher degree of absolute sensitivity is

usually necessary in drag than in lift, and some stability in respect of the lift measurements is useful, especially at large angles where the lift arm tends to oscillate violently.

It was shown in Part II that the synchronism of the movements of the model in two planes affects the sensitivity in lift, the lift being modified by the angle of yaw which the model assumes when the drag beam moves from its neutral position. This effect obviously does not appear in the Curtiss balance, where the measurements of lift and drag are taken at different times.

In respect of most of the errors discussed in Part III, and of the accuracy necessary in the sliding of various parts, the Curtiss balance stands on exactly the same footing as does the N. P. L. type. The balance carried on two widely separated knife-edges obviously needs no strut and spring clamp to prevent rotation about a vertical axis, and the elimination of these members, together with the natural superiority of a knife-edge over a pivot makes the friction in the Curtiss balance materially smaller than that in the single-pivot type. The only important counterbalancing disadvantage is the time required to make two separate runs.

Pitching moments are measured by an entirely self-contained device, making no contact with the frame. The model is carried on a rod which passes down through the hollow upper portion of the balance. The lower end of the rod is pointed and rests in a conical socket. This rod has attached to it a horizontal bar which projects through a hole in the wall of the balance, and which bears against the end of the vertical arm of a bell crank, on the horizontal arm of which weight is hung to balance the pitching moments. The moment guide arm is carried by the upper part of the balance proper, which therefore never makes any contact with the balance frame except through the knife-edges. This method of measuring moments is essentially similar in principle to that used at Langley Field, has the same merits, and is subject to the same criticisms.

(4) WRIGHT.

In the balance designed by Mr. Orville Wright, and used in his wind tunnel at Dayton, the L/D ratio can be found directly by measuring the slope of the vector. The model is carried by one side of an articulated parallelogram, the opposite side of which is fixed relative to the tunnel. The model therefore moves parallel to itself, and takes up a position such that the two free sides of the parallelogram are parallel to the vector (if the plane of the linkage is vertical, the vertical links must, of course, be prolonged and counterweighted, the counterweights being adjusted so that, with the model in place and no wind on, the linkage will remain in any position in which it is set).

The major disadvantage of this system is the minuteness of the angles which must be measured. If an L/D of 16 is to be determined with an error not in excess of 1 per cent, the slope of the vector must be read off correct within 0.0036 . This corresponds to a distance of 0.16 mm. at the tip of a pointer 25 cm. long. The difficulty of reading angles as closely as this must always be considerable, even if the pointer remains perfectly steady. With care, however, the flexible linkage method is capable of giving very accurate results.

When the lift and drag are to be measured separately these forces are balanced against the drag on a wire screen. The force is read directly from the position of a pointer on a scale, and no such adjustments are necessary as had to be made in the Lanchester and Dines balances (see Part II).

This balance is easy and quick to use, although it requires two runs to secure the lift and drag. It is hardly to be expected, however, that it can give the accuracy attainable by other methods. If the same screen is used as standard throughout a single test for wing drag, the maximum force to be measured will be more than 10 times as large as the minimum, and the inclination of the screen must accordingly vary through nearly 90° . The determination of the smallest force to within 1 per cent would necessitate the division of the scale into 1,000 parts, and the reading of divisions so fine as these would be exceedingly difficult, especially as the pointer is certain to move slightly, pulsations in velocity of the wind not affecting the wing and the screen at the same time.

The linkage on a tunnel of this type may be placed either inside or outside the tunnel. In the first case the linkage interferes seriously with the flow around the model. In the second case the force on the model, acting out of the plane of the linkage, produces torsion in the links and greatly augments the friction at the joints.

Great care is necessary in aligning the linkage with the wind, the errors due to a fraction of a degree of misalignment being as serious as in the N. P. L. balance. There are nine joints which come into play in the Wright balance when it is used for measuring the components of force separately. The conclusion is that, for accurate work, this balance is probably inferior to several other types, but that it would be very convenient for securing comparative results in a hurry, particularly if the wind velocity were subject to fluctuations which would make it difficult to balance the fluctuating air resistance against fixed weights in the usual way. The Wright balance is more accurate and satisfactory for measurements of L/D than for either force alone.



The Wright balance is a type of balance in which the forces are measured by means of a linkage system. It is used for measuring the components of force separately. The conclusion is that, for accurate work, this balance is probably inferior to several other types, but that it would be very convenient for securing comparative results in a hurry, particularly if the wind velocity were subject to fluctuations which would make it difficult to balance the fluctuating air resistance against fixed weights in the usual way. The Wright balance is more accurate and satisfactory for measurements of L/D than for either force alone.

WRIGHT

The Wright balance is a type of balance in which the forces are measured by means of a linkage system. It is used for measuring the components of force separately. The conclusion is that, for accurate work, this balance is probably inferior to several other types, but that it would be very convenient for securing comparative results in a hurry, particularly if the wind velocity were subject to fluctuations which would make it difficult to balance the fluctuating air resistance against fixed weights in the usual way. The Wright balance is more accurate and satisfactory for measurements of L/D than for either force alone.

The Wright balance is a type of balance in which the forces are measured by means of a linkage system. It is used for measuring the components of force separately. The conclusion is that, for accurate work, this balance is probably inferior to several other types, but that it would be very convenient for securing comparative results in a hurry, particularly if the wind velocity were subject to fluctuations which would make it difficult to balance the fluctuating air resistance against fixed weights in the usual way. The Wright balance is more accurate and satisfactory for measurements of L/D than for either force alone.

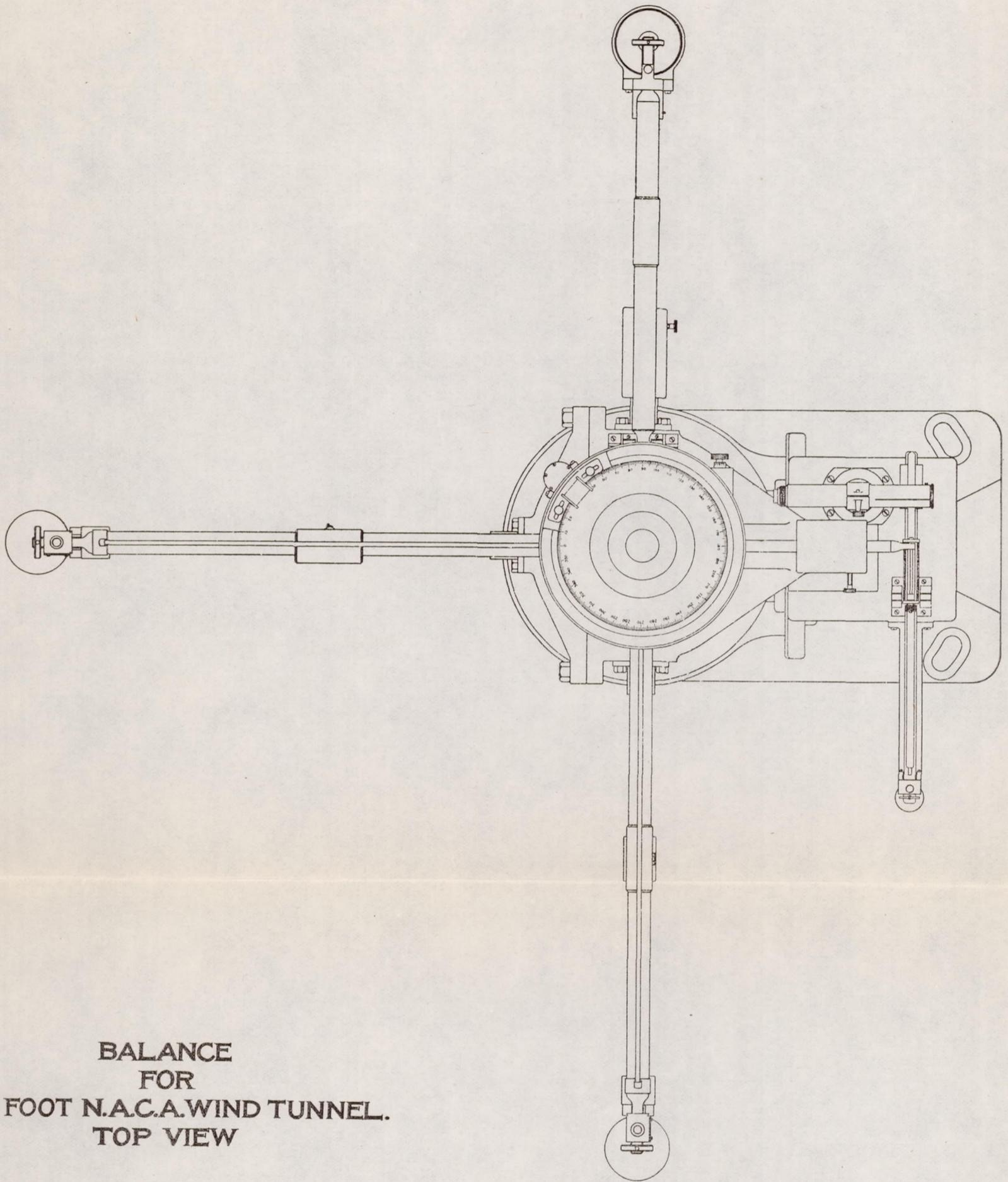

BALANCE
FOR
FIVE FOOT N.A.C.A. WIND TUNNEL.
TOP VIEW

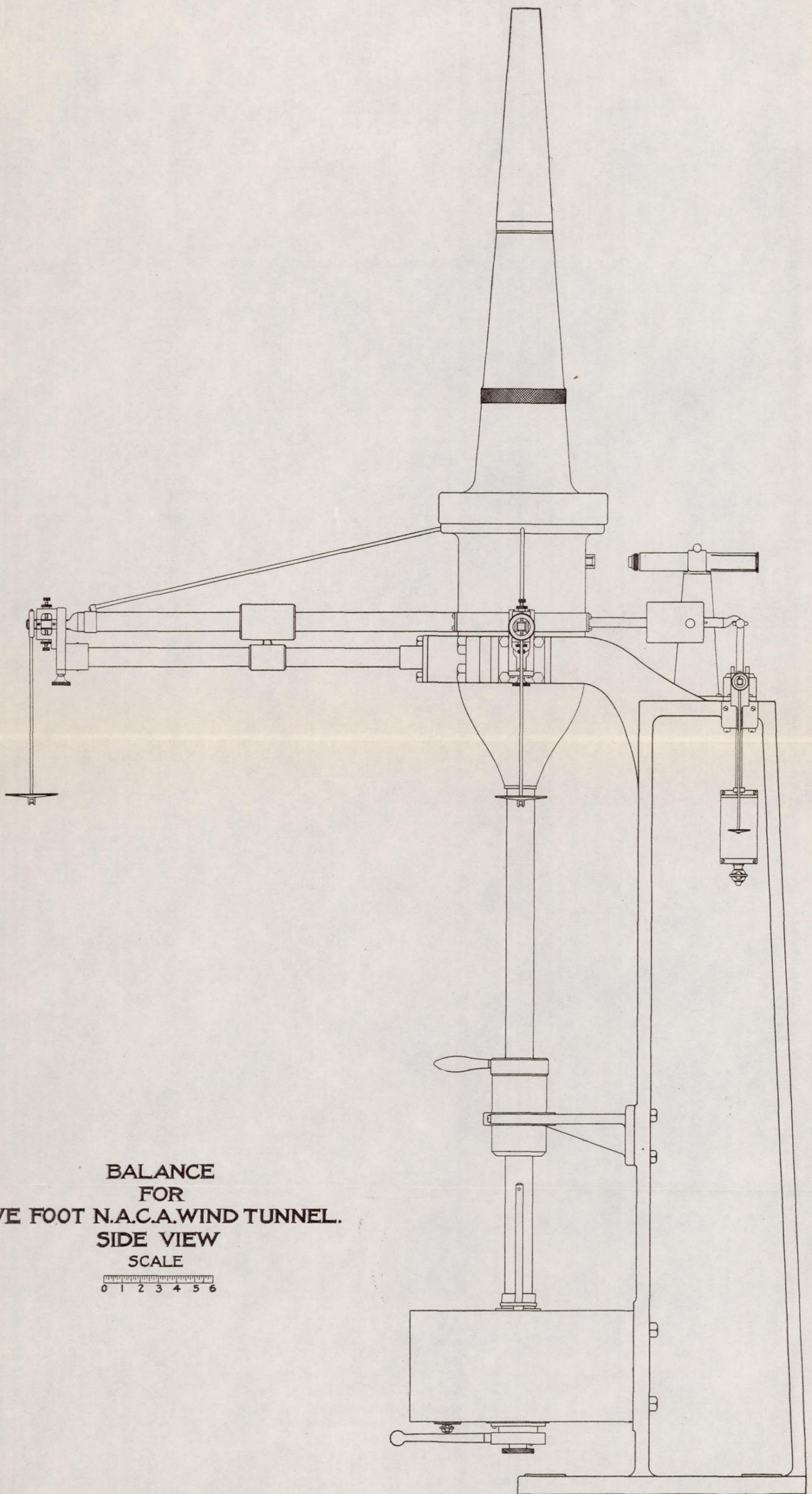

BALANCE
FOR
FIVE FOOT N.A.C.A. WIND TUNNEL.
SIDE VIEW
SCALE

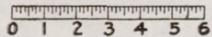

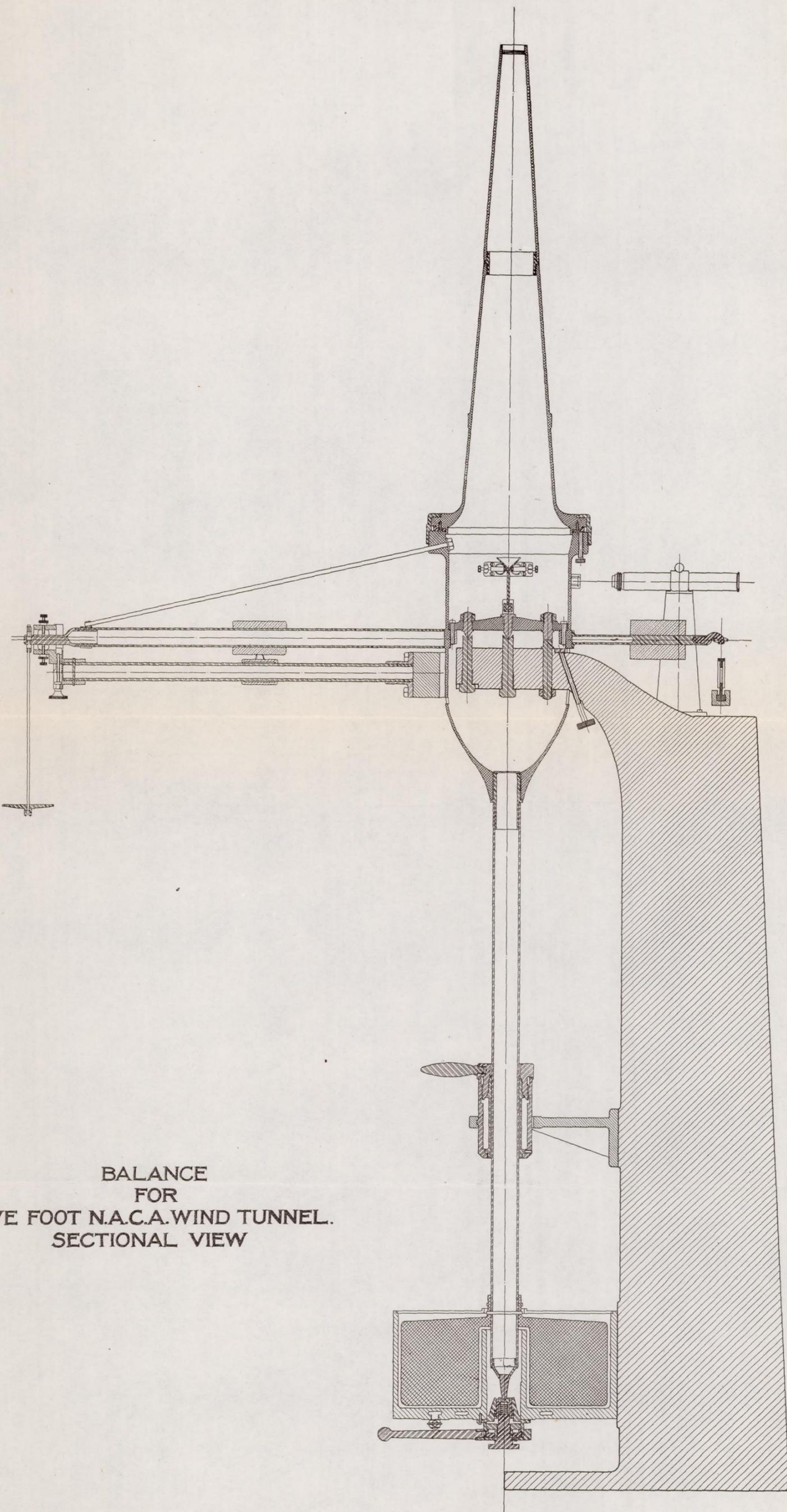

BALANCE
FOR
FIVE FOOT N.A.C.A. WIND TUNNEL.
SECTIONAL VIEW

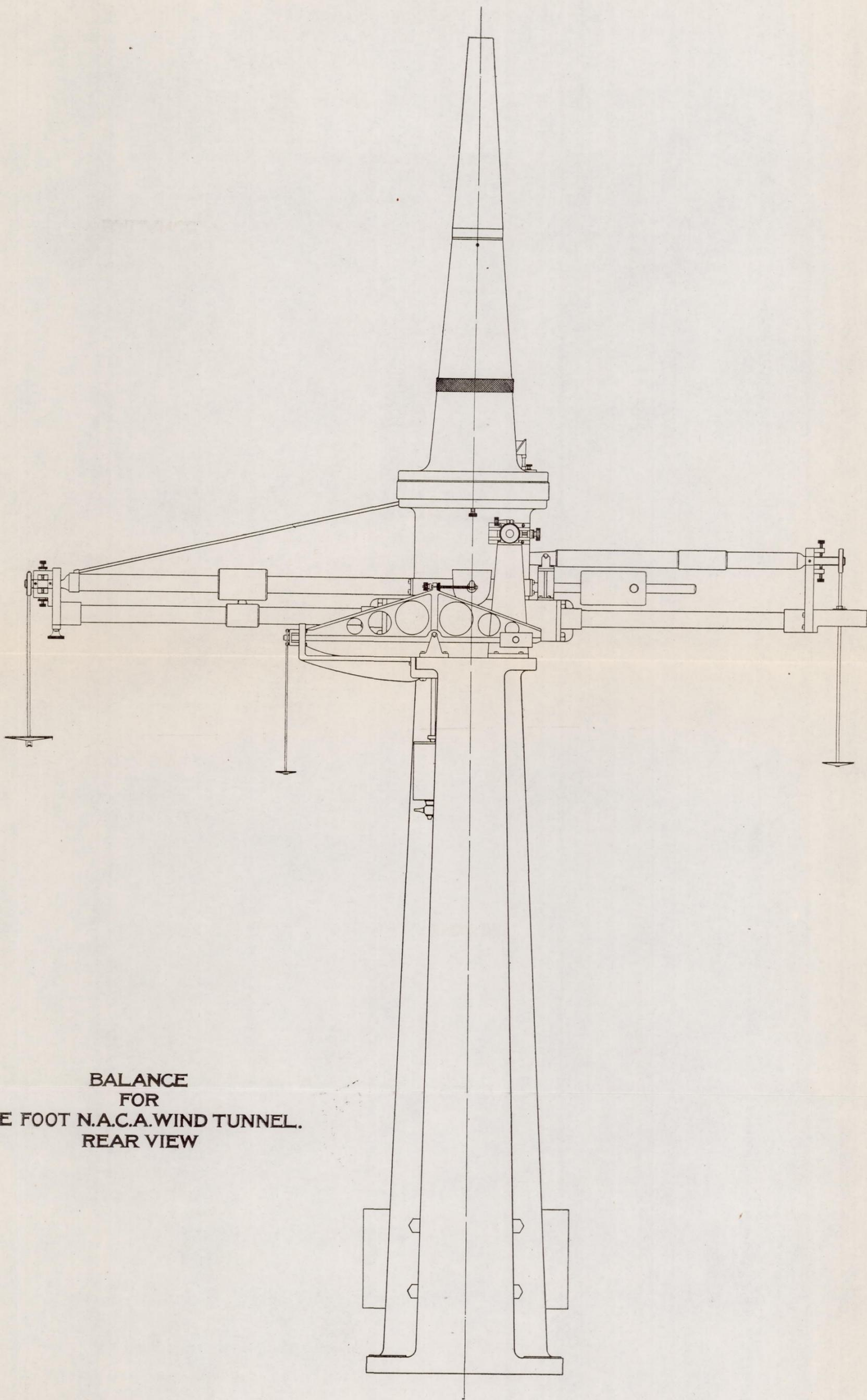

BALANCE
FOR
FIVE FOOT N.A.C.A. WIND TUNNEL.
REAR VIEW