

FILE COPY
NO

NATIONAL ADVISORY COMMITTEE FOR AERONAUTICS

REPORT No. 326

TESTS OF FIVE METAL MODEL PROPELLERS WITH VARIOUS PITCH DISTRIBUTIONS IN A FREE WIND STREAM AND IN COMBINATION WITH A MODEL VE-7 FUSELAGE

By E. P. LESLEY and ELLIOTT G. REID

THIS DOCUMENT ON LOAN FROM THE FILES OF
NATIONAL ADVISORY COMMITTEE FOR AERONAUTICS
LANGLEY AERONAUTICAL LABORATORY
LANGLEY FIELD, HAMPTON, VIRGINIA



RETURN TO THE ABOVE ADDRESS.
REQUESTS FOR PUBLICATIONS SHOULD BE ADDRESSED
AS FOLLOWS:

NATIONAL ADVISORY COMMITTEE FOR AERONAUTICS
1512 H STREET, N. W.
WASHINGTON 25, D. C.

AERONAUTICAL SYMBOLS

1. FUNDAMENTAL AND DERIVED UNITS

	Symbol	Metric		English	
		Unit	Symbol	Unit	Symbol
Length.....	<i>l</i>	meter.....	m	foot (or mile).....	ft. (or mi.)
Time.....	<i>t</i>	second.....	sec	second (or hour).....	sec. (or hr.)
Force.....	<i>F</i>	weight of one kilogram.....	kg	weight of one pound	lb.
Power.....	<i>P</i>	kg/m/sec.....		horsepower.....	HP.
Speed.....		km/hr.....		mi./hr.....	M. P. H.
		m/sec.....		ft./sec.....	f. p. s.

2. GENERAL SYMBOLS, ETC.

<p><i>W</i>, Weight, = mg</p> <p><i>g</i>, Standard acceleration of gravity = 9.80665 m/sec.² = 32.1740 ft./sec.²</p> <p><i>m</i>, Mass, = $\frac{W}{g}$</p> <p>ρ, Density (mass per unit volume). Standard density of dry air, 0.12497 (kg-m⁻⁴ sec.²) at 15° C and 760 mm = 0.002378 (lb.- ft.⁻⁴ sec.²).</p> <p>Specific weight of "standard" air, 1.2255 kg/m³ = 0.07651 lb./ft.³</p>	<p>mk^2, Moment of inertia (indicate axis of the radius of gyration, <i>k</i>, by proper sub- script).</p> <p><i>S</i>, Area.</p> <p><i>S_w</i>, Wing area, etc.</p> <p><i>G</i>, Gap.</p> <p><i>b</i>, Span.</p> <p><i>c</i>, Chord length.</p> <p><i>b/c</i>, Aspect ratio.</p> <p><i>f</i>, Distance from <i>c. g.</i> to elevator hinge.</p> <p>μ, Coefficient of viscosity.</p>
---	--

3. AERODYNAMICAL SYMBOLS

<p><i>V</i>, True air speed.</p> <p><i>q</i>, Dynamic (or impact) pressure = $\frac{1}{2} \rho V^2$</p> <p><i>L</i>, Lift, absolute coefficient $C_L = \frac{L}{qS}$</p> <p><i>D</i>, Drag, absolute coefficient $C_D = \frac{D}{qS}$</p> <p><i>C</i>, Cross-wind force, absolute coefficient $C_C = \frac{C}{qS}$</p> <p><i>R</i>, Resultant force. (Note that these coeffi- cients are twice as large as the old co- efficients <i>L_c</i>, <i>D_c</i>.)</p> <p><i>i_w</i>, Angle of setting of wings (relative to thrust line).</p> <p><i>i_t</i>, Angle of stabilizer setting with reference to thrust line.</p>	<p>γ, Dihedral angle.</p> <p>$\rho \frac{Vl}{\mu}$, Reynolds Number, where <i>l</i> is a linear dimension. e. g., for a model airfoil 3 in. chord, 100 mi./hr. normal pressure, 0° C: 255,000 and at 15° C., 230,000; or for a model of 10 cm chord 40 m/sec, corresponding numbers are 299,000 and 270,000.</p> <p><i>C_p</i>, Center of pressure coefficient (ratio of distance of <i>C. P.</i> from leading edge to chord length).</p> <p>β, Angle of stabilizer setting with reference to lower wing, = (<i>i_t</i> - <i>i_w</i>).</p> <p>α, Angle of attack.</p> <p>ϵ, Angle of downwash.</p>
--	--

REPORT No. 326

**TESTS OF FIVE METAL MODEL PROPELLERS WITH
VARIOUS PITCH DISTRIBUTIONS IN A FREE
WIND STREAM AND IN COMBINATION
WITH A MODEL VE-7 FUSELAGE**

**By E. P. LESLEY and ELLIOTT G. REID
Stanford University**

NATIONAL ADVISORY COMMITTEE FOR AERONAUTICS

NAVY BUILDING, WASHINGTON, D. C.

(An independent Government establishment, created by act of Congress approved March 3, 1915, for the supervision and direction of the scientific study of the problems of flight. It consists of 15 members who are appointed by the President, all of whom serve as such without compensation.)

JOSEPH S. AMES, Ph. D., *Chairman.*
President, Johns Hopkins University, Baltimore, Md.
DAVID W. TAYLOR, D. Eng., *Vice Chairman.*
Washington, D. C.
CHARLES G. ABBOT, Sc. D.,
Secretary, Smithsonian Institution, Washington, D. C.
GEORGE K. BURGESS, Sc. D.,
Director, Bureau of Standards, Washington, D. C.
WILLIAM F. DURAND, Ph. D.,
Professor Emeritus of Mechanical Engineering, Stanford University, California.
JAMES E. FECHET, Major General, United States Army,
Chief of Air Corps, War Department, Washington, D. C.
WILLIAM E. GILMORE, Brigadier General, United States Army,
Chief, Matériel Division, Air Corps, Wright Field, Dayton, Ohio.
HARRY F. GUGGENHEIM, M. A.,
President, The Daniel Guggenheim Fund for the Promotion of Aeronautics, Inc., New
York City.
EMORY S. LAND, Captain, United States Navy.
WM. P. MACCRACKEN, Jr., Ph. B.,
Assistant Secretary of Commerce for Aeronautics.
CHARLES F. MARVIN, M. E.,
Chief, United States Weather Bureau, Washington, D. C.
WILLIAM A. MOFFETT, Rear Admiral, United States Navy,
Chief, Bureau of Aeronautics, Navy Department, Washington, D. C.
S. W. STRATTON, Sc. D.,
President Massachusetts Institute of Technology, Cambridge, Mass.
EDWARD P. WARNER, M. S.,
Cambridge, Mass.
ORVILLE WRIGHT, Sc. D.,
Dayton, Ohio.

GEORGE W. LEWIS, *Director of Aeronautical Research.*
JOHN F. VICTORY, *Secretary.*
HENRY J. E. REID, *Engineer in Charge, Langley Memorial Aeronautical Laboratory,*
Langley Field, Va.
JOHN J. IDE, *Technical Assistant in Europe, Paris, France.*

EXECUTIVE COMMITTEE

JOSEPH S. AMES, *Chairman.*
DAVID W. TAYLOR, *Vice Chairman.*

CHARLES G. ABBOT.	CHARLES F. MARVIN.
GEORGE K. BURGESS.	WILLIAM A. MOFFETT.
JAMES E. FECHET.	S. W. STRATTON.
WILLIAM E. GILMORE.	ORVILLE WRIGHT.
EMORY S. LAND.	

JOHN F. VICTORY, *Secretary.*

TECHNICAL REPORT No. 326

TESTS OF FIVE METAL MODEL PROPELLERS WITH VARIOUS PITCH DISTRIBUTIONS IN A FREE WIND STREAM AND IN COMBINATION WITH A MODEL VE-7 FUSELAGE

By E. P. LESLEY and ELLIOTT G. REID

SUMMARY

This report describes the tests of five adjustable blade metal model propellers both in a free wind stream and in combination with a model fuselage with stub wings, which were conducted at Stanford University under research authorization of the National Advisory Committee for Aeronautics. The propellers are of the same form and cross section but have variations in radial distributions of pitch. By making a survey of the radial distribution of air velocity through the propeller plane of the model fuselage it is found that this velocity varies from zero at the hub center to approximately free stream velocity at the blade tip.

The tests show that the efficiency of a propeller when operating in the presence of the airplane is, over the working range, generally less than when operating in a free wind stream, but that a propeller with a radial distribution of pitch of the same nature as the radial distribution of air velocity through the propeller plane suffers the smallest loss in efficiency.

INTRODUCTION

In the design of propellers it is generally customary to assume that the axial velocity through the propeller disk is uniform. It has recently been demonstrated (reference 1), however, that such is not the case; the velocity through the propeller plane of a fuselage of conventional form is relatively small in the immediate vicinity of the fuselage. The purpose of the present investigation was to determine the importance of considering this feature in the design of propellers. To this end, the performance characteristics of five model propellers, alike in plan form and blade sections and having approximately the same mean pitch, but with various radial distributions of pitch, have been determined both in the free stream and in the presence of a model fuselage.

A model VE-7 fuselage with stub wings was chosen as a typical slip stream obstruction. The form of the model fuselage is shown in Figure 1. The scale ratio between the model and full size is 0.3674, thus giving a diameter of 3 feet for the model propeller, and a chord of 20.39 inches for the model wing. The model propellers are shown in Figure 2. The blades of all models are adjustable and all fit a single hub. Propeller A is, at the blade angles shown, of uniform geometric pitch and has a geometric pitch/diameter ratio of 7/10. Propellers B and C are of the same form and pitch as A from hub to 10.8-inch radius; from this point to the tip B is gradually increased in pitch and C is gradually decreased. Propellers D and E are the same as propeller A from the 10.8-inch radius outward; from this point toward the hub the blade angles of D are increased and those of E are decreased.

Reference 1. The Effect of the Sperry Messenger Fuselage on the Air Flow at the Propeller Plane. By Fred E. Weick. N. A. C. A. Technical Note No. 274.

PROGRAM OF TESTS

The program for tests was as follows:

1. Tests in an unobstructed wind stream.
 - (a) Tests of propeller A with blades set at the designed angles.
Reduction of observed data to the usual coefficients

$$C_P = \frac{\text{Power}}{\rho n^3 D^5}, \quad C_T = \frac{\text{Thrust}}{\rho n^2 D^4}$$

and η = efficiency, and plotting of same on abscissa of V/nD .

Calculation of speed power coefficient

$$C_{P_1} = \sqrt{\frac{\rho V^5}{\text{Power } n^2}}$$

and plotting same against V/nD and efficiency, thus determining value of such coefficient for maximum efficiency.

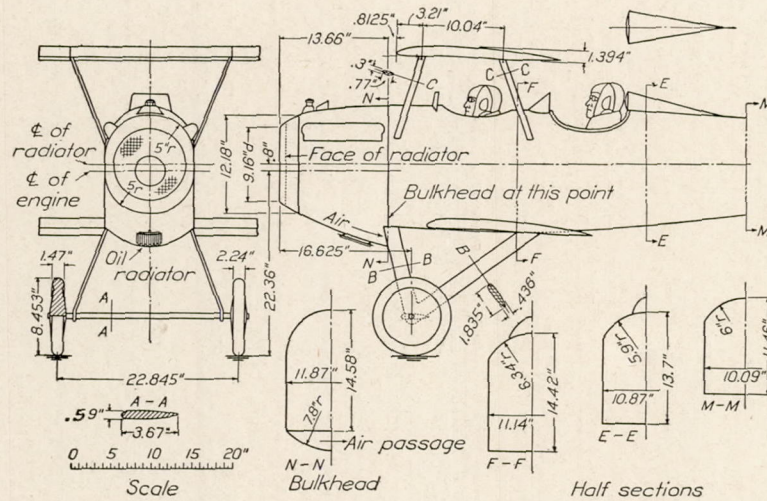

FIGURE 1.—Wind tunnel model of VE-7 airplane
Chord, 20.36 inches; gap, 20.55 inches; stagger, 4.13 inches; angle of wing setting (upper wing)
1° 45'; lower, 2° 15'.

- (b) Preliminary tests of propellers B, C, D, and E at various blade settings and at values of V/nD in the neighborhood of that for maximum efficiency, to determine the setting giving maximum efficiency for the same value of the speed-power coefficient

$$\sqrt{\frac{\rho V^5}{P n^2}}$$

as that determined for propeller A at maximum efficiency.

- (c) Complete tests of propellers B, C, D, and E at the settings determined by (b).
2. Tests of model propellers in combination with the VE-7 model fuselage and stub wings.
 - (a) Tests similar to 1 (a).
 - (b) Tests similar to 1 (b).
 - (c) Tests similar to 1 (c).
3. Survey of the velocity distribution at the propeller plane of the VE-7 model.

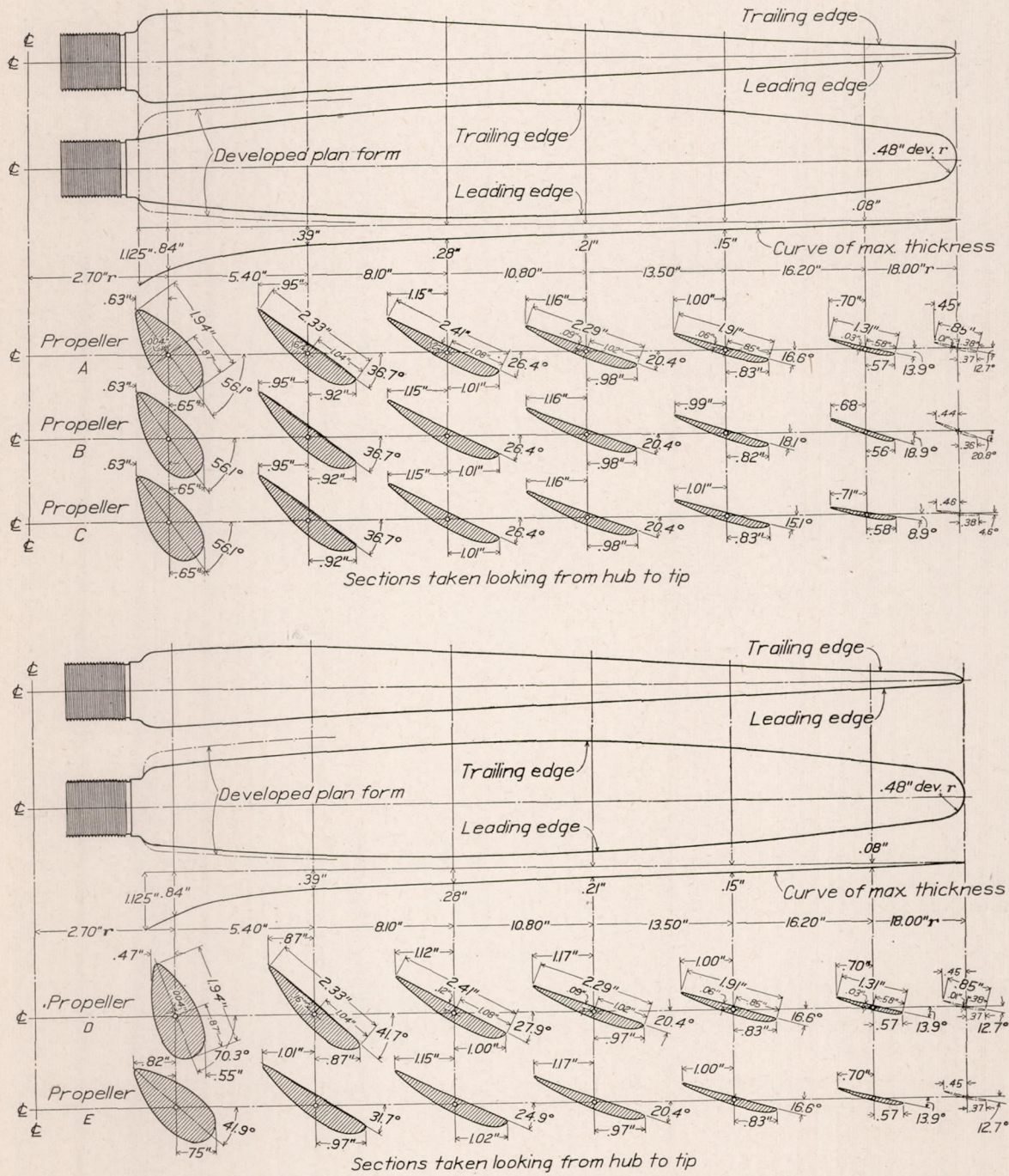

FIGURE 2.—Model propellers A, B, C, D, and E, with varying pitch distribution, but with no change in blade section dimensions

SET-UP OF APPARATUS AND METHOD OF TESTS

The apparatus for the free wind stream tests is shown in Figure 3. The model propellers are mounted on the shaft of a cradle type dynamometer placed at the axis of the wind tunnel.

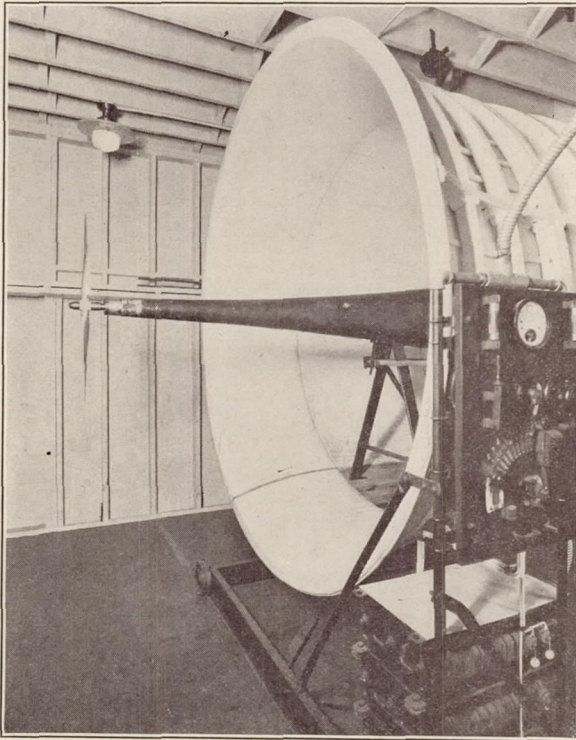

FIGURE 3.—Arrangement of apparatus for free stream tests

The dynamometer barrel, containing the driving motor at the rear end, is long and tapering, the test propeller being $5\frac{1}{2}$ feet in front of any appreciable obstruction and thus in a wind stream of sensibly uniform velocity.

Torque and thrust are measured directly. Revolutions are recorded upon a chronograph and wind speed is determined from the pressure reduction in the experiment chamber and the air density, the relation between experiment chamber pressure reduction and dynamic pressure having been previously determined from a survey with a pitot tube. Air density is determined from observed dry and wet bulb temperature and barometric pressure by reference to tables of General Specifications—Appendix 8, Instructions for Calculating and Testing Ventilating Systems, Bureau of Construction and Repair, United States Navy Department. The usual test procedure is as follows:

1. Check torque and thrust zeros.
2. With wind speed of about 66 feet per second, adjust angular velocity of propeller to give zero thrust and make simultaneous observations for thrust, torque, angular velocity and wind velocity.

3. Increase thrust in suitable increments to give well distributed spots on graphs by increasing angular velocity and make similar observations. This process is continued (with 3-foot models) until a thrust of 30 pounds is reached. The slip is increased for additional observations by reduction of wind velocity until the tunnel fan is shut down entirely, the velocity for the last observation being only that induced in the tunnel by the action of the model propeller itself.

The set-up for tests of the propellers in combination with the VE-7 model fuselage is shown in Figure 4.

In former tests of this kind the model airplane was suspended by wires as shown and the drag was measured by means of a balance forward of the experiment chamber, the connection to the balance being a wire with suitable bridle around the propeller. Preliminary tests were made to determine the drag of the model without the propeller. The drag of the model was also measured

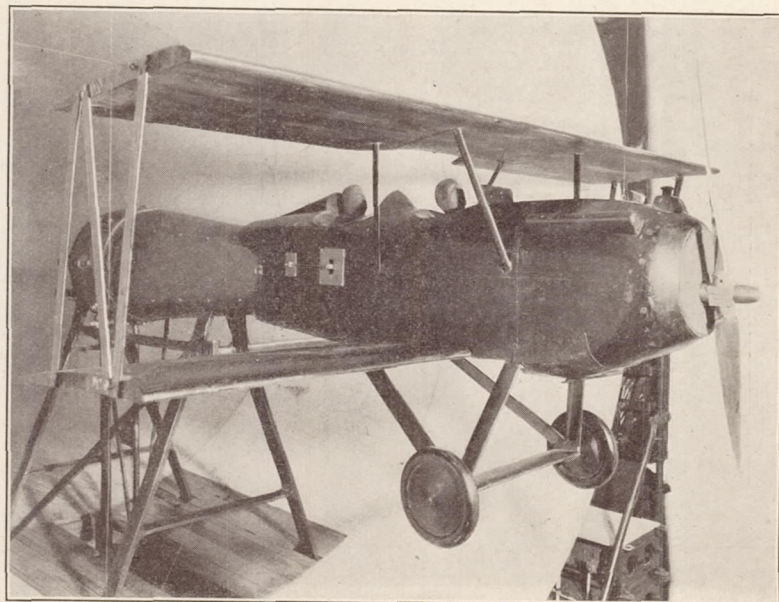

FIGURE 4.—Arrangement of apparatus for test with model fuselage

with the propeller in operation. The thrust of the propeller was measured as in the free wind stream tests. For determining the propeller characteristics when operating in combination with the model, the propeller was credited with a thrust equal to $T - (R_1 - R_0)$ in which T is the pull upon the propeller shaft as indicated by the thrust balance, R_0 the resistance of the model in a free wind stream and R_1 the resistance of the model when influenced by the propeller.

In the present tests a method simpler for experimental observations, but giving the same final result, was employed. The model airplane was suspended by wires as before. A drag yoke connecting the model to the thrust bearing of the dynamometer was provided. This yoke insured no interference with or effect upon the torque balance. The drag of the model was thus indicated as a negative thrust by the thrust balance beam.

A preliminary test was made to determine the drag or resistance of the model alone.

The procedure for tests of model propellers in combination with the model fuselage was the same as that for the tests in a free wind stream, except that the observations were started at a negative value of the total force upon the propeller shaft about equal to the drag of the model fuselage alone so that the propeller was delivering under this condition approximately zero effective thrust.

With the drag of the model communicated to the thrust balance, it is evident that the force measured by the thrust balance is $T - R_1$, T being as in previous tests the pull exerted by the propeller and R_1 the resistance of the model under the action of wind and slip stream. If to $T - R_1$ is added the resistance of the model in a free wind stream, R_0 , the result is $T - R_1 + R_0$ or $T - (R_1 - R_0)$ the quantity which was determined in previous tests when the drag of the model as influenced by the slip stream was measured independently.

The velocity survey of the propeller plane was confined to three radii, the upward and downward verticals and one horizontal. Observations were made at 2-inch intervals out to the 24-inch radius. The arrangement of the survey apparatus is illustrated by Figure 5. The small pitot tube, built to meet space limitations, was calibrated, while attached to its supporting bar, by comparative tests with a standard National Advisory Committee for Aeronautics pitot tube.

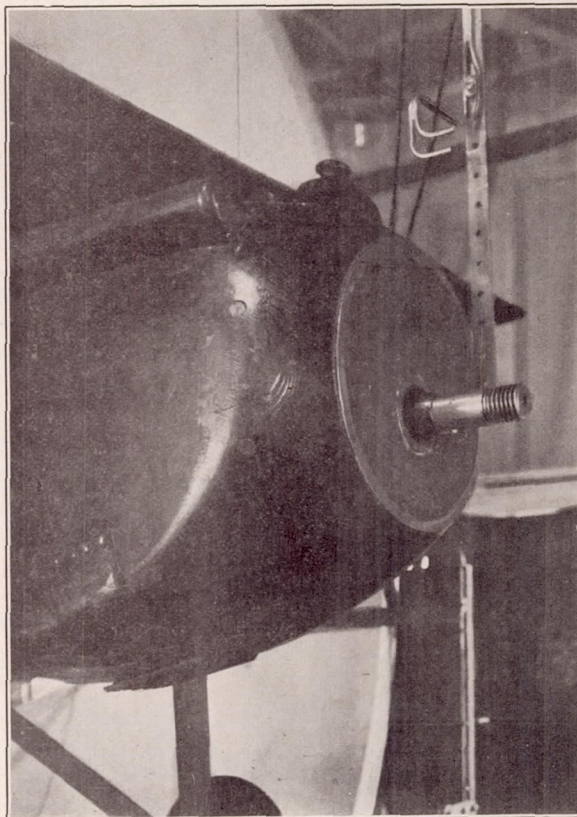

FIGURE 5.—Apparatus for velocity survey

RESULTS OF TESTS

The results of free wind stream tests on propeller A are given in Table Ia and are shown in Figure 6. From the figure it is seen that the maximum efficiency is somewhat above 81 per cent and that the corresponding value of the speed-power coefficient is 1.75. Preliminary tests near the point of maximum efficiency for propellers B, C, D, and E gave the following results:

Propeller	Blade setting at 10.8-inch radius	Speed power coefficient for maximum efficiency	Propeller	Blade setting at 10.8-inch radius	Speed power coefficient for maximum efficiency
B.....	20-25	2.00	D.....	20-25	1.90
B.....	17-25	1.60	D.....	19-00	1.60
B.....	18-15	1.75	D.....	19-30	1.65
C.....	20-25	1.24	D.....	19-55	1.75
C.....	21-55	1.60	E.....	20-25	1.65
C.....	22-15	1.65	E.....	20-40	1.75
C.....	23-05	1.75			

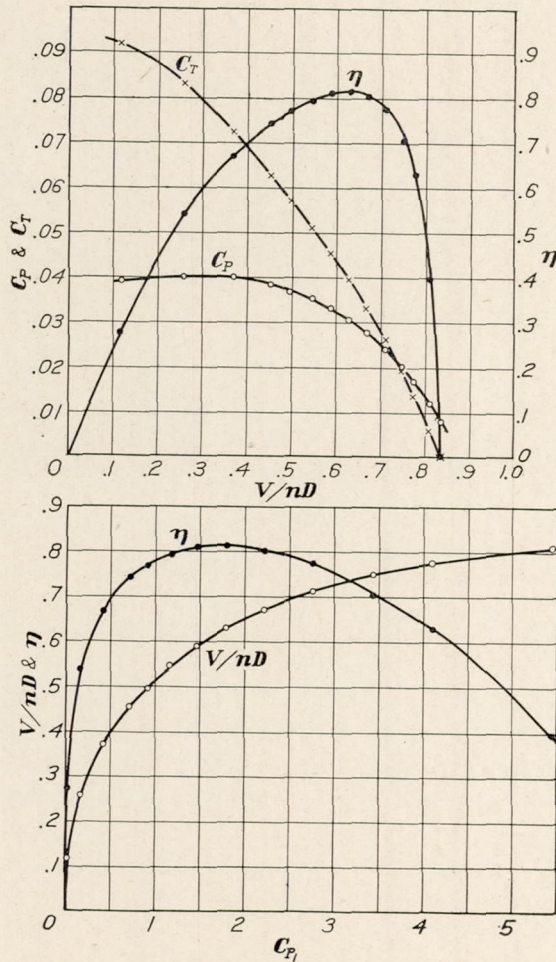

FIGURE 6.—Propeller A in free wind stream

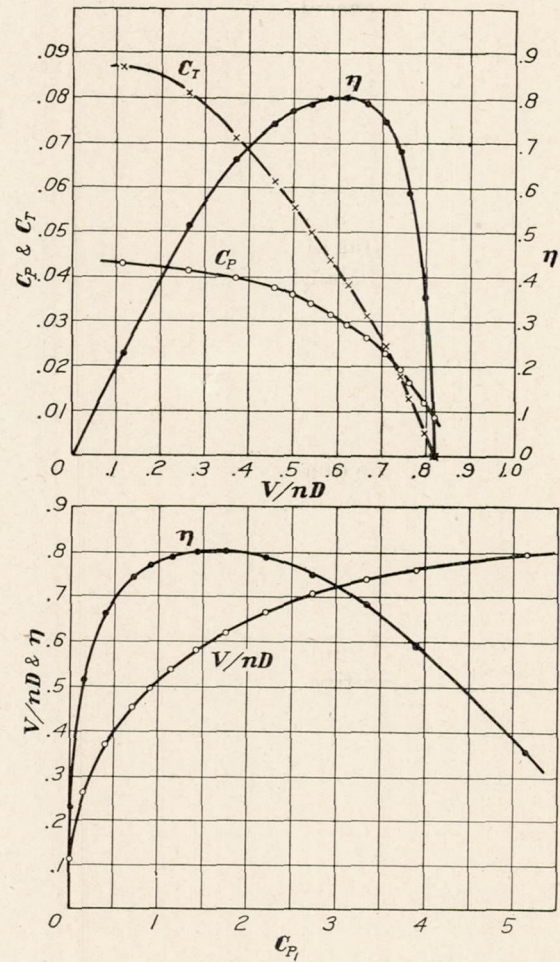

FIGURE 7.—Propeller B in free wind stream

From the above it was determined that the settings for B, C, D, and E at the 10.8-inch radius to give a speed-power coefficient of 1.75 at maximum efficiency were as follows:

Propeller	B	C	D	E
Setting at 10.8-inch radius	18.2°	23.1°	19.9°	20.7°

It may be noted that the angles of B are decreased 2.2° and those of C are increased 2.7°. Likewise the angles of D are decreased 0.5° while those of E are increased 0.3°.

Some apparent inconsistency in the changes required led to the measurement of the angles on all propellers from the 10.8-inch radius outward. No attempt was made to measure the angles inside of the 10.8-inch radius, since the sections are cambered on the driving face and no accurate method for measuring was available. The angles of corresponding sections for two blades of a single propeller were found to differ, in some cases, by 0.1° . The mean angles (for two blades) showed no differences from those of Figure 2 greater than 0.2° .

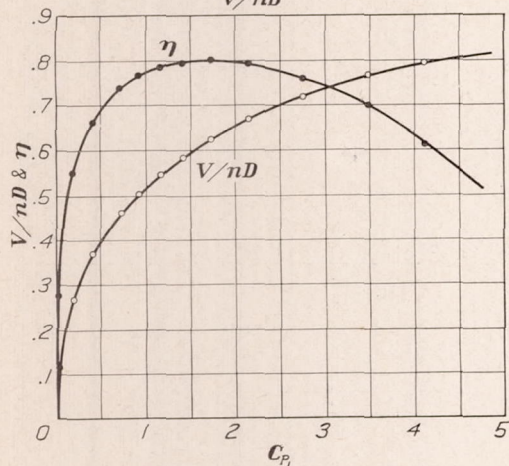
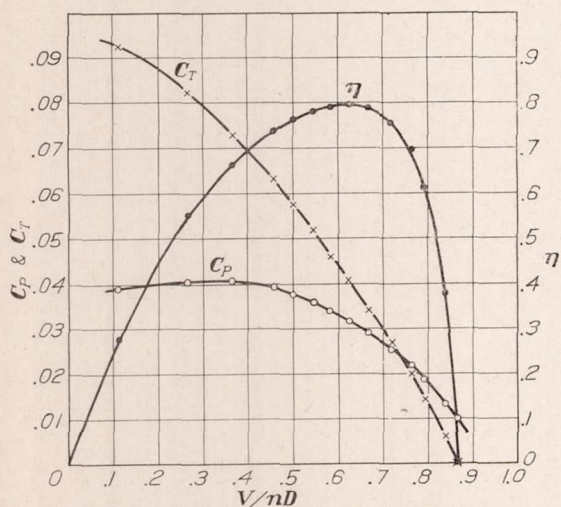

FIGURE 8.—Propeller C in free wind stream

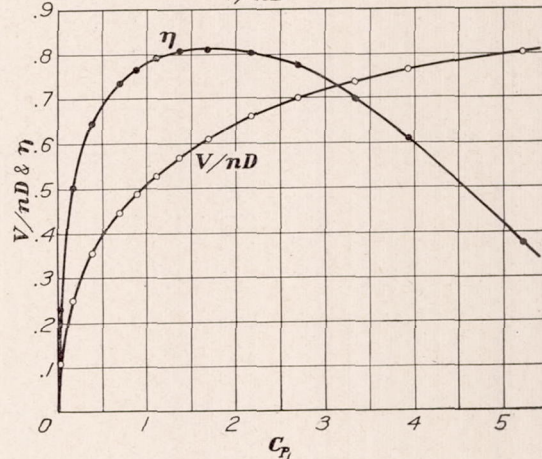
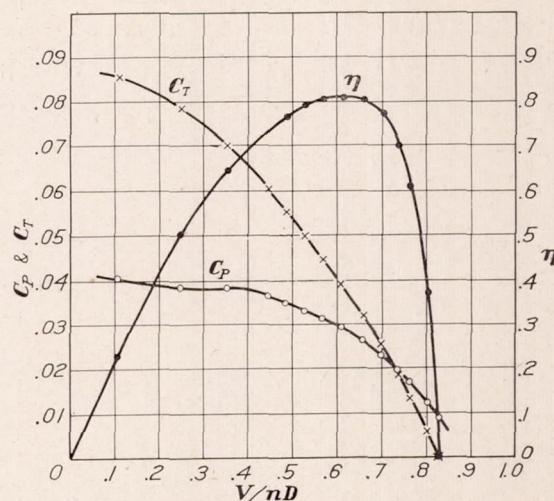

FIGURE 9.—Propeller D in free wind stream

Assuming that the angles of the sections inside of the 10.8-inch radius were, in relation to angle at the 10.8-inch section, as shown by Figure 2, the angles of all sections were, for the settings used, as follows:

Angle of section—	Radius					
	2.7-inch	5.4-inch	8.1-inch	10.8-inch	13.5-inch	16.2-inch
A.....	56.1	36.7	26.4	20.4	16.5	14.0
B.....	53.9	34.5	24.2	18.2	16.0	16.7
C.....	58.8	39.4	29.1	23.1	17.9	11.8
D.....	69.8	41.2	27.4	19.9	16.0	13.2
E.....	42.2	32.0	25.2	20.7	17.1	14.3

The results of complete tests in a free wind stream for propellers B, C, D, and E are given in Tables Ib, Ic, Id, and Ie and are shown in Figures 7, 8, 9, and 10.

The observed data from the preliminary tests of the model VE-7 for drag without slip stream are shown in Table II and Figure 11.

The results of tests of propeller A in combination with the model VE-7 are given in Table IIIa and are shown in Figure 12. As stated previously the thrust credited to the propeller is the observed total force on the shaft as shown by the thrust balance plus the resistance, R_0 , corresponding to the observed dynamic pressure and read from the graph Figure 11. For this reason the initial value of thrust is not zero as in the case of the unobstructed wind stream

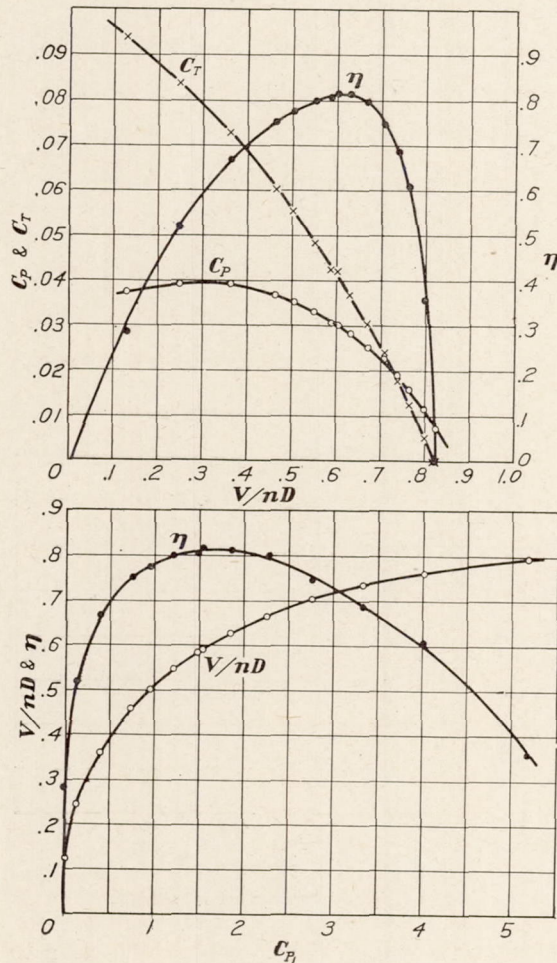

FIGURE 10.—Propeller E in free wind stream

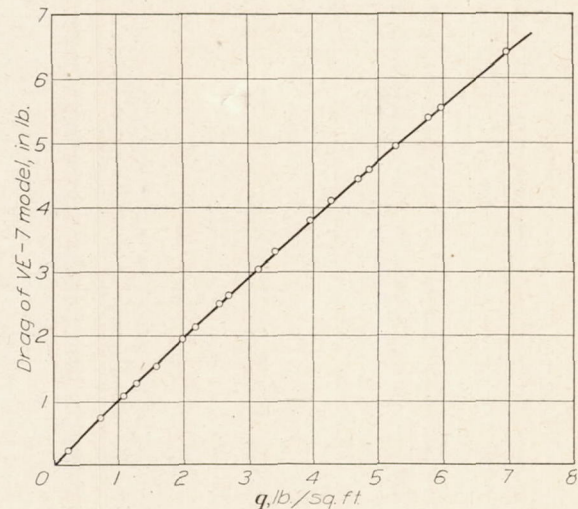

FIGURE 11.—Drag on the VE-7 model

tests, it being impracticable to determine in advance the exact value of dynamic pressure that would be encountered and thus adjust the propeller speed to give a total reaction upon the shaft equal in amount to the resistance of the model without slip stream effect.

Figure 12 shows that the maximum efficiency of propeller A, when operating in front of the model, is slightly over 76 per cent and that this efficiency occurs at a speed power coefficient of 1.85.

Preliminary tests of propellers B, C, D, and E in combination with the VE-7 model showed that no changes of the settings derived in the free stream preliminary tests were required, the value of the speed-power coefficient being, at these settings, 1.85 for maximum efficiency.

The results of complete tests of propellers B, C, D, and E in combination with the model plane are given in Tables IIIb, IIIc, IIId, and IIIe and are shown in Figures 13, 14, 15, and 16.

Table IV and Figure 17 show the results of the velocity survey at the propeller plane. In this survey preliminary tests showed that the ratio of velocity at any point to free stream velocity was practically independent of the velocity employed. Figure 18 shows the ratio of mean velocity in the propeller plane to free stream velocity. This figure is determined by taking the mean

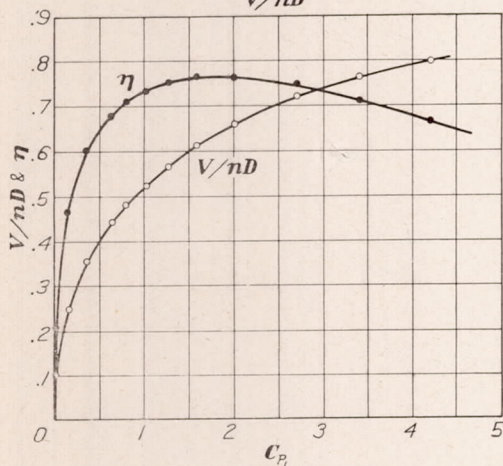
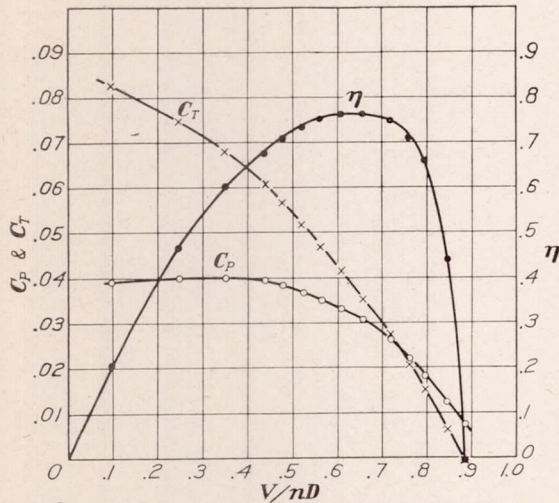

FIGURE 12.—Propeller A with model fuselage

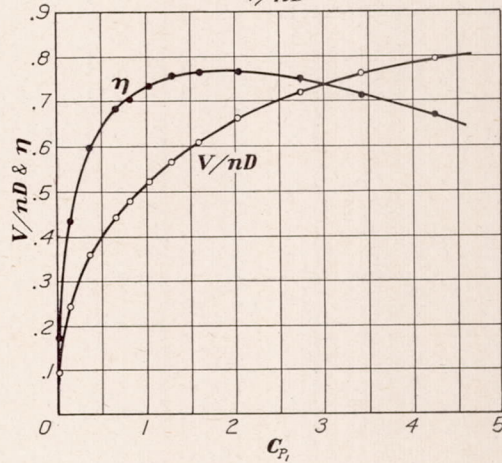
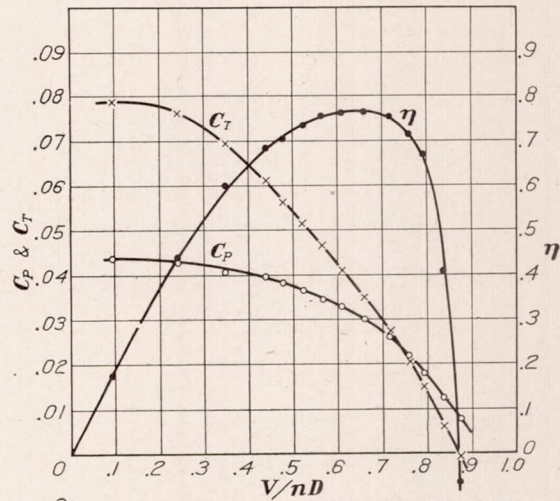

FIGURE 13.—Propeller B with model fuselage

of the ordinates of Figure 17, but including the ordinate for left side twice, it being assumed that the velocity distribution is symmetrical in a horizontal plane.

DISCUSSION

Inspection of Figures 6, 7, 8, 9, and 10 reveals that, so far as can be judged from free stream performance, no one of these propellers has a striking advantage over any other. With possibly a slight advantage in favor of A, propellers A, D, and E are about equal with a peak efficiency of somewhat over 81 per cent. For B and C the peak efficiency is close to 80 per cent, B appearing to be slightly the better.

Neglecting inflow velocity, the angles of attack of the various sections of the five propellers, when operating in a wind stream of uniform velocity and at V/nD for maximum efficiency, are as follows:

ANGLES OF ATTACK OF SECTIONS AT V/nD FOR MAXIMUM EFFICIENCY FOR PROPELLERS IN FREE WIND STREAM

Angles of attack of section—	Radius						
	2.7-inch	5.4-inch	8.1-inch	10.8-inch	13.5-inch	16.2-inch	18-inch
	°	°	°	°	°	°	°
A.....	3.1	3.2	2.6	2.1	1.7	1.5	1.5
B.....	1.2	1.2	0.5	0.0	1.3	4.4	7.5
C.....	5.7	5.8	5.2	4.7	3.0	-0.7	-4.0
D.....	17.2	8.0	3.9	1.6	1.3	0.9	1.1
E.....	-10.4	-1.2	1.6	2.6	2.4	2.1	1.9

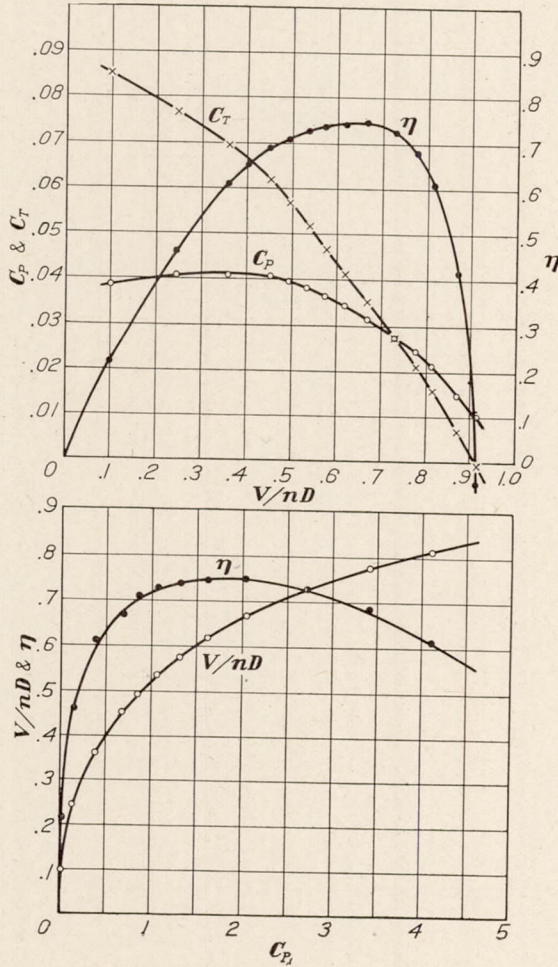

FIGURE 14.—Propeller C with model fuselage

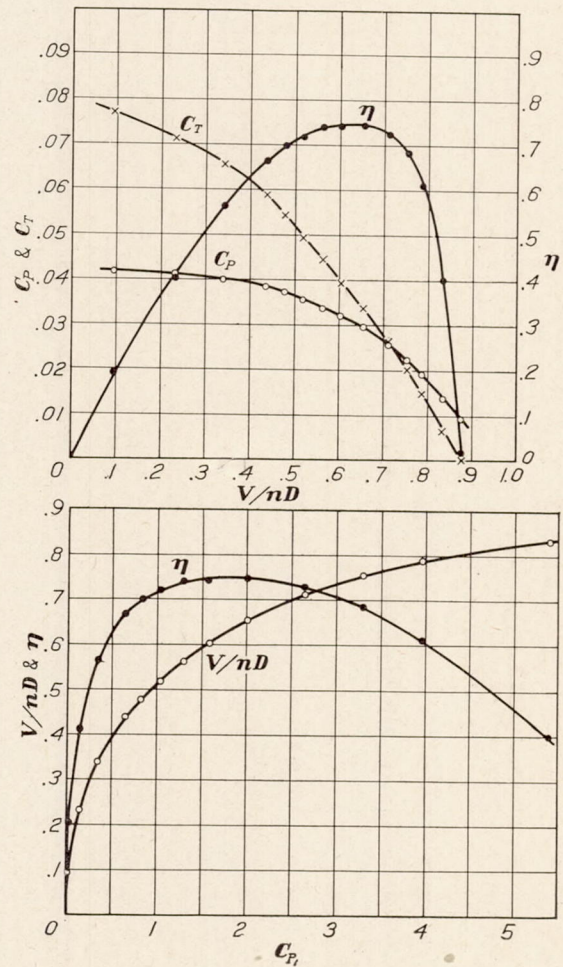

FIGURE 15.—Propeller D with model fuselage

These angles are shown graphically in Figure 19. Without knowing the aerodynamic characteristics of the sections, it is of course impossible to say what the optimum angles of attack are; but assuming that they are moderate and approximately uniform, it would appear from Figure 19 that propeller A should be the best. It would seem, too, that D and E should be next, because of the relative importance of the outer sections, and that B and C should be poorest. It might be expected that D and E would be appreciably inferior to A, but, in view of the fact that there is only a little more than 1 per cent difference in the peak efficiencies of

the best and worst propellers (A and C) the slight differences found in A, D, and E are not surprising.

For the tests in combination with the model fuselage it is seen from Figures 12 to 16 that all propellers show a decrease in peak efficiency from that determined by the free stream tests and an increase in V/nD for zero thrust. This is in agreement with previous tests of a similar nature. (Reference 2.)

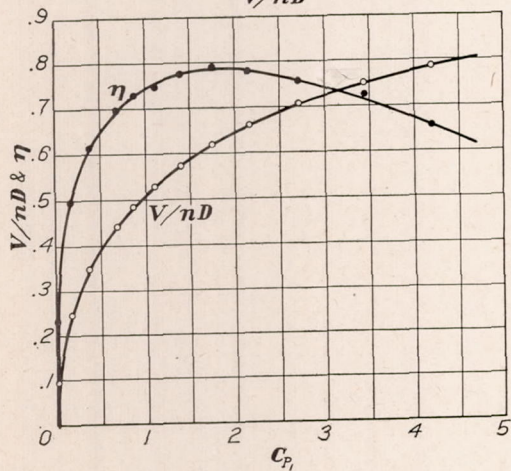
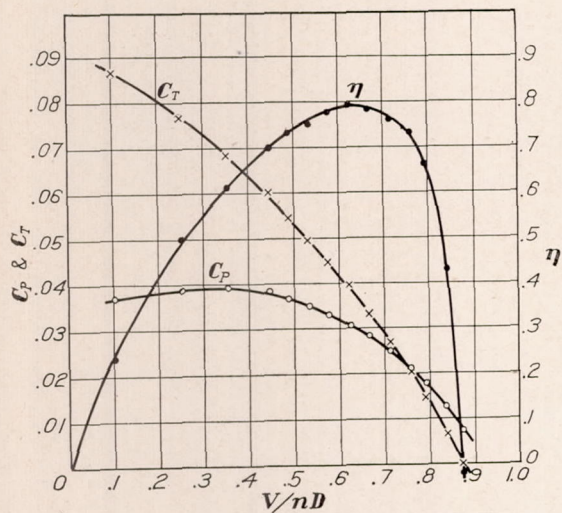

FIGURE 16.—Propeller E with model fuselage

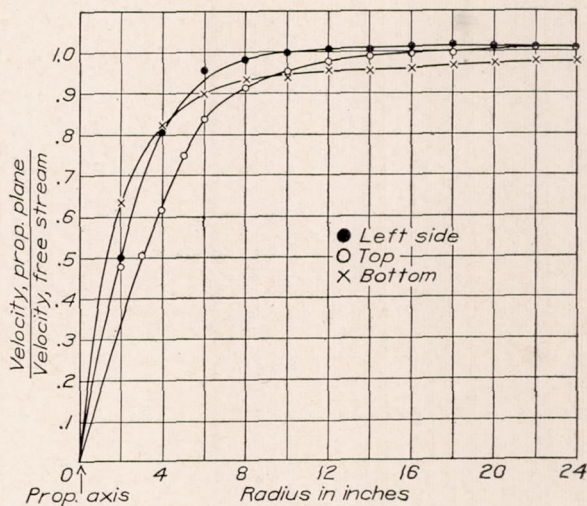

FIGURE 17.—Survey of velocity in propeller plane. VE-7 model

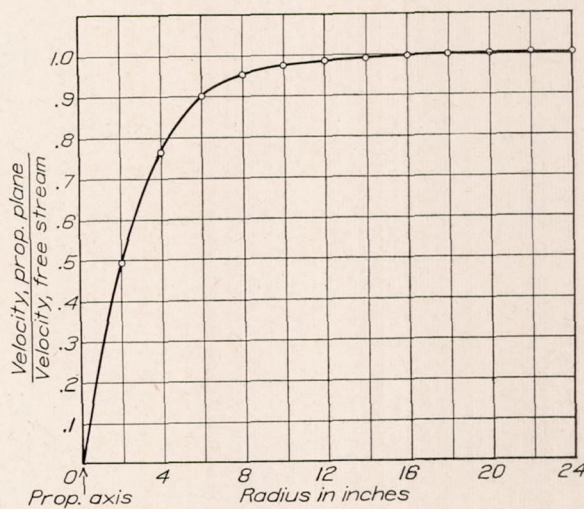

FIGURE 18.—Velocity in propeller plane, average. VE-7 model

The decrease in peak efficiency is, however, not the same for all propellers, so that the peak efficiencies attained are as follows:

Propeller	A	B	C	D	E
Peak efficiency with model fuselage, per cent	76¼	76¼	75	75	79

Reference 2. Interaction between Air Propellers and Airplane Structures, by W. F. Durand. N. A. C. A. Technical Report No. 235.

Again, neglecting inflow velocity and assuming a radial velocity distribution as shown by Figure 18, the angles of attack for the various sections of the five propellers when operating in front of the model fuselage at V/nD for maximum efficiency are as follows:

ANGLES OF ATTACK OF SECTIONS AT V/nD FOR MAXIMUM EFFICIENCY FOR PROPELLERS IN COMBINATION WITH MODEL FUSELAGE

Angles of attack of section—	Radius						
	2.7-inch	5.4-inch	8.1-inch	10.8-inch	13.5-inch	16.2-inch	18-inch
A	16.5	6.1	3.0	2.1	1.5	1.3	1.2
B	14.3	4.4	0.8	-0.1	1.0	4.0	7.1
C	19.0	8.6	5.6	4.7	2.8	-1.0	-4.3
D	30.4	10.8	4.2	1.7	1.1	0.6	0.8
E	2.8	1.6	2.0	2.5	2.2	1.7	1.6

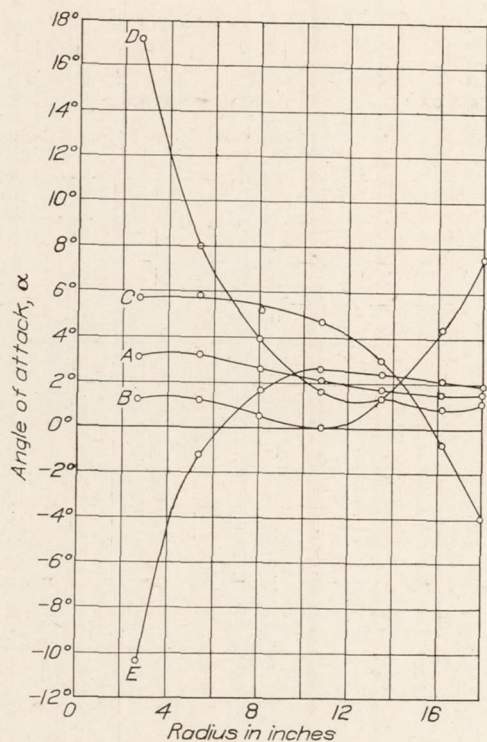

FIGURE 19.—Angles of attack of sections at V/nD for maximum efficiency. Free wind stream

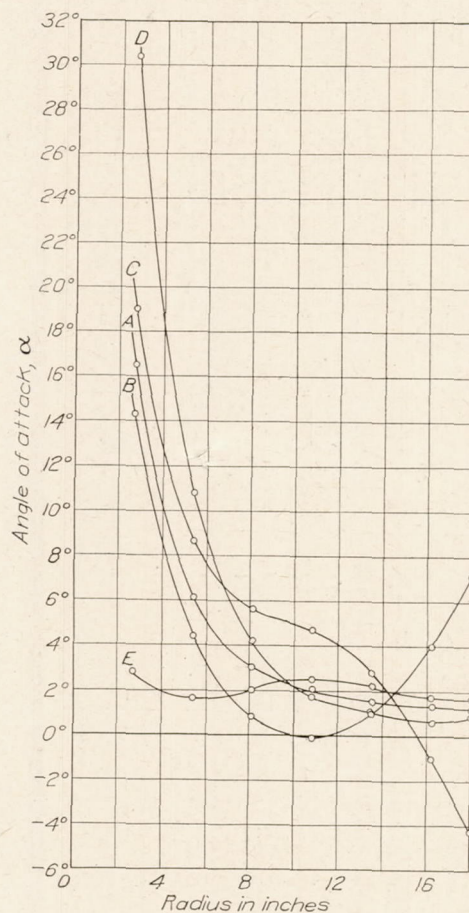

FIGURE 20.—Angles of attack of sections at V/nD for maximum efficiency with model fuselage

These angles are shown graphically in Figure 20. The angles for propeller E are small and nearly uniform and have probably somewhere near the optimum values. The angles for A and B are without doubt distinctly less favorable for high efficiency and those for C and D may be even worse.

CONCLUSIONS

It has been demonstrated by these tests that the reduction of propeller efficiency caused by the presence of an obstruction in the slip stream is minimized by giving the propeller a radial distribution of pitch similar to the radial distribution of velocity through the propeller plane

which exists under the conditions of operation. In other words, a propeller so designed that all its blade sections actually attain their optimum angles of attack at the condition of maximum efficiency is appreciably superior to the conventional constant pitch propeller for use in the presence of a slip stream obstruction.

STANFORD UNIVERSITY,
December, 1928.

TABLE Ia.—PROPELLER A

[Free wind stream]

$\frac{1}{2}\rho V^2$	ρ spec. wt. slugs/cu. ft.	V, veloc- ity, ft./sec.	r. p. s. n	n^2	Thrust, lb.	Torque, lb.-ft.	V/nD	$C_T = \frac{\text{Thrust}}{\rho n^2 D^4}$	$C_P = \frac{\text{Power}}{\rho n^3 D^5}$	Efficiency η	$C_{P_1} = \sqrt{\frac{\rho V^3}{P n^2}}$
4.760	0.002264	64.85	25.83	667.2	0	0.4579	0.8366	0	0.007838	0	7.235
4.857	.002262	65.55	27.00	729.0	.7592	.7440	.8092	.005684	.01167	.3940	5.453
4.996	.002240	66.80	28.72	824.8	2.025	1.193	.7751	.01353	.01669	.6283	4.095
5.013	.002234	66.98	29.78	886.8	3.037	1.528	.7494	.01892	.01994	.7034	3.443
4.936	.002234	66.45	31.16	970.9	4.555	1.999	.7106	.02594	.02382	.7738	2.761
4.993	.002234	66.87	33.28	1,108.0	6.580	2.626	.6698	.03283	.02743	.8015	2.218
5.097	.002231	67.62	35.82	1,283.0	9.111	3.370	.6290	.03930	.03044	.8120	1.789
5.144	.002232	67.92	38.50	1,482.0	12.15	4.209	.5878	.04533	.03290	.8098	1.459
5.244	.002234	68.54	41.90	1,756.0	16.20	5.320	.5452	.05100	.03507	.7928	1.171
5.375	.002234	69.35	46.60	2,172.0	22.27	6.860	.4960	.05670	.03654	.7693	.9063
5.542	.002235	70.41	51.76	2,679.0	30.37	8.859	.4533	.06264	.03825	.7420	.7080
3.192	.002238	53.40	48.20	2,323.0	30.37	8.008	.3691	.07208	.03981	.6684	.4146
1.354	.002241	34.77	44.85	2,016.0	30.37	6.958	.2584	.08300	.03982	.5386	.1704
.2525	.002242	15.01	42.70	1,823.0	30.37	6.162	.1171	.09174	.03900	.2754	.02376

TABLE Ib.—PROPELLER B

[Free wind stream]

$\frac{1}{2}\rho V^2$	ρ spec. wt. slugs/cu. ft.	V, veloc- ity, ft./sec.	r. p. s. n	n^2	Thrust, lb.	Torque, lb.-ft.	V/nD	$C_T = \frac{\text{Thrust}}{\rho n^2 D^4}$	$C_P = \frac{\text{Power}}{\rho n^3 D^5}$	Efficiency η	$C_{P_1} = \sqrt{\frac{\rho V^3}{P n^2}}$
4.919	0.002259	66.00	26.85	721.0	0	0.5624	0.8194	0	0.008934	0	6.425
4.980	.002254	66.50	27.90	778.4	.7592	.8092	.7946	.005343	.01193	.3559	5.150
5.028	.002252	66.81	29.30	858.5	2.025	1.244	.7601	.01294	.01665	.5906	3.903
5.072	.002250	67.15	30.31	918.7	3.037	1.563	.7385	.01813	.01955	.6848	3.350
5.104	.002246	67.40	31.82	1,013.0	4.555	2.056	.7061	.02472	.02336	.7472	2.737
5.139	.002243	67.66	33.93	1,151.0	6.580	2.648	.6646	.03149	.02652	.7891	2.210
5.095	.002246	67.32	36.23	1,313.0	9.111	3.362	.6193	.03816	.02950	.8007	1.756
5.176	.002245	67.92	38.96	1,518.0	12.15	4.204	.5811	.04400	.03192	.8004	1.442
5.223	.002243	68.23	42.20	1,781.0	16.20	5.295	.5390	.05006	.03428	.7870	1.153
5.408	.002243	69.40	46.73	2,184.0	22.27	6.856	.4952	.05612	.03620	.7678	.907
5.674	.002242	71.12	52.07	2,711.0	30.37	8.894	.4553	.06167	.03784	.7420	.717
3.226	.002246	53.56	48.50	2,352.0	30.37	8.076	.3681	.07096	.03956	.6606	.414
1.422	.002249	35.55	45.33	2,055.0	30.37	7.369	.2614	.08112	.04125	.5140	.171
.2493	.002250	14.89	43.80	1,918.0	30.37	7.170	.1133	.08688	.04298	.2290	.021

TABLE Ic.—PROPELLER C

[Free wind stream]

$\frac{1}{2}\rho V^2$	ρ spec. wt. slugs/cu. ft.	V, veloc- ity, ft./sec.	r. p. s. n	n^2	Thrust, lb.	Torque, lb.-ft.	V/nD	$C_T = \frac{\text{Thrust}}{\rho n^2 D^4}$	$C_P = \frac{\text{Power}}{\rho n^3 D^5}$	Efficiency η	$C_{P_1} = \sqrt{\frac{\rho V^3}{P n^2}}$
4.796	0.002242	65.41	25.20	635.0	0	0.5500	0.8652	0	0.009992	0	6.965
4.894	.002239	66.14	26.29	691.2	.7592	.7988	.8386	.006058	.01335	.3806	5.569
4.919	.002236	66.30	27.87	776.7	2.025	1.246	.7930	.01439	.01857	.6145	4.106
4.969	.002234	66.68	28.98	839.8	3.037	1.588	.7670	.01998	.02188	.7004	3.479
4.882	.002234	66.14	30.57	934.5	4.555	2.065	.7212	.02696	.02561	.7592	2.758
4.770	.002233	65.38	32.52	1,058.0	6.580	2.658	.6702	.03439	.02911	.7918	2.154
4.850	.002233	65.93	35.16	1,236.0	9.111	3.394	.6251	.04077	.03182	.8007	1.732
4.984	.002234	66.82	38.09	1,451.0	12.15	4.295	.5848	.04626	.03429	.7940	1.412
5.194	.002233	68.23	41.59	1,730.0	16.20	5.395	.5468	.05176	.03612	.7836	1.164
5.399	.002232	69.55	46.14	2,129.0	22.27	6.958	.5025	.05790	.03789	.7680	.919
5.626	.002232	71.00	51.43	2,645.0	30.37	9.014	.4602	.06354	.03952	.7400	.721
3.121	.002235	52.85	47.85	2,290.0	30.37	8.060	.3682	.07325	.04075	.6618	.408
1.479	.002240	36.34	45.01	2,026.0	30.37	7.100	.2692	.08265	.04046	.5499	.186
.2462	.002241	14.82	42.48	1,805.0	30.37	6.107	.1163	.09271	.03907	.2760	.023

TABLE Id.—PROPELLER D

[Free wind stream]

$\frac{1}{2}\rho V^2$	ρ spec. wt. slugs/cu. ft.	V , veloc- ity, ft./sec.	r. p. s. n	n^2	Thrust, lb.	Torque, lb.-ft.	V/nD	$C_T = \frac{\text{Thrust}}{\rho n^2 D^4}$	$C_P = \frac{\text{Power}}{\rho n^3 D^5}$	Efficiency η	$C_{P_1} = \sqrt{\frac{\rho V^3}{P n^2}}$
4.715	0.002284	64.27	25.82	666.7	0	0.5201	0.8298	0	0.00883	0	6.667
4.802	.002280	64.92	26.93	725.2	0.7592	.7814	.8033	.00567	.012225	.3726	5.228
4.912	.002276	65.65	28.64	820.2	2.025	1.209	.7640	.01339	.01676	.6104	3.940
4.934	.002275	65.82	29.72	883.3	3.037	1.528	.7383	.01866	.01967	.7003	3.335
4.875	.002270	65.53	31.15	970.3	4.555	1.969	.7012	.02553	.02312	.7743	2.704
4.957	.002269	66.08	33.42	1,117.0	6.580	2.576	.6591	.03204	.02629	.8032	2.173
4.802	.002270	65.06	35.58	1,266.0	9.111	3.273	.6095	.03913	.02946	.8095	1.690
4.878	.002270	65.55	38.47	1,480.0	12.15	4.083	.5680	.04464	.03143	.8066	1.370
5.036	.002270	66.60	42.12	1,774.0	16.20	5.154	.5271	.04966	.03309	.7910	1.110
5.293	.002267	68.34	46.91	2,201.0	22.27	6.767	.4856	.05514	.03509	.7630	.878
5.526	.002264	69.90	52.37	2,743.0	30.37	8.786	.4450	.06040	.03660	.7343	.692
3.019	.002267	51.60	48.62	2,364.0	30.37	7.947	.3538	.06994	.03835	.6453	.330
1.322	.002269	34.13	45.92	2,109.0	30.37	7.168	.2477	.07832	.03874	.5007	.155
.232	.002272	14.29	43.93	1,930.0	30.37	6.819	.1084	.08552	.04023	.2304	.019

TABLE Ie.—PROPELLER E

[Free wind stream]

$\frac{1}{2}\rho V^2$	ρ spec. wt. slugs/cu. ft.	V , veloc- ity, ft./sec.	r. p. s. n	n^2	Thrust, lb.	Torque, lb.-ft.	V/nD	$C_T = \frac{\text{Thrust}}{\rho n^2 D^4}$	$C_P = \frac{\text{Power}}{\rho n^3 D^5}$	Efficiency η	$C_{P_1} = \sqrt{\frac{\rho V^3}{P n^2}}$
4.986	0.002337	65.32	26.52	703.3	0	0.5421	0.8214	0	0.008536	0	6.620
4.994	.002337	65.36	27.37	749.1	.7592	.8007	.7960	.005354	.011836	.3598	5.190
5.105	.002333	66.20	28.98	839.8	2.025	1.209	.7614	.01277	.01596	.6090	4.002
5.100	.002333	66.18	29.98	898.8	3.037	1.552	.7359	.01788	.01914	.6870	3.355
5.201	.002332	66.80	31.58	997.3	4.555	2.049	.7052	.02418	.02278	.7482	2.763
5.323	.002329	67.58	33.85	1,146.0	6.580	2.616	.6655	.03046	.02534	.7994	2.273
5.425	.002328	68.26	36.26	1,315.0	9.111	3.362	.6276	.03675	.02840	.8120	1.853
5.425	.002328	68.26	38.98	1,519.0	12.15	4.202	.5838	.04244	.03072	.8033	1.485
5.594	.002349	69.01	39.03	1,523.0	12.15	4.197	.5895	.04195	.03033	.8152	1.533
5.542	.002328	68.99	42.12	1,774.0	16.20	5.282	.5400	.04845	.03308	.7996	1.212
5.703	.002328	69.98	46.64	2,175.0	22.27	6.868	.5002	.05430	.03510	.7738	.945
5.906	.002328	71.20	51.70	2,673.0	30.37	8.871	.4590	.06025	.03686	.7504	.744
2.972	.002331	50.50	47.01	2,210.0	30.37	7.778	.3581	.07280	.03904	.6676	.389
1.190	.002334	31.95	43.81	1,919.0	30.37	6.794	.2431	.08370	.03920	.5190	.1468
.2278	.002335	13.96	41.38	1,712.0	30.37	5.769	.1125	.09380	.03733	.2826	.0189

TABLE II.—DRAG OF THE VE-7 MODEL

$\frac{1}{2}\rho V^2$	Drag, lb.	$\frac{1}{2}\rho V^2$	Drag, lb.
0.2258	0.23	3.428	3.28
.7280	.72	3.960	3.75
1.0665	1.05	4.276	4.05
1.2780	1.25	4.658	4.39
1.5695	1.53	4.857	4.54
1.9920	1.93	5.288	4.91
2.200	2.12	5.763	5.35
2.557	2.46	5.976	5.50
2.698	2.60	6.997	6.35
3.147	3.00		

TABLE IIIa.—PROPELLER A

[With model fuselage]

$\frac{1}{2}\rho V^2$	ρ spec. wt. slugs/cu. ft.	V , veloc- ity, ft./sec.	r. p. s. n	n^2	Thrust, lb.	Torque, lb.-ft.	V/nD	$C_T = \frac{\text{Thrust}}{\rho n^2 D^4}$	$C_P = \frac{\text{Power}}{\rho n^3 D^5}$	Efficiency η	$C_{P_1} = \sqrt{\frac{\rho V^3}{P n^2}}$
4.764	0.002271	64.80	24.40	595.4	-0.05568	0.3808	0.8850	-0.0005083	0.00728	-0.0618	8.639
4.800	.002268	65.07	25.63	656.9	+ .7541	.7092	.8459	+ .006248	.01231	.4295	5.933
4.850	.002268	65.40	27.36	748.6	2.055	1.180	.7966	.01495	.01798	.6624	4.223
4.878	.002264	65.66	28.69	823.1	3.093	1.588	.7625	.02049	.02202	.7094	3.423
4.936	.002262	66.07	30.54	932.7	4.657	2.148	.7208	.02726	.02632	.7466	2.720
4.483	.002263	62.93	31.81	1,012.0	6.535	2.700	.6592	.03522	.03048	.7615	2.020
4.533	.002262	63.32	34.57	1,195.0	9.106	3.476	.6105	.04160	.03323	.7640	1.599
4.641	.002262	64.07	37.82	1,430.0	12.27	4.410	.5646	.04683	.03510	.7530	1.278
4.820	.002261	65.34	41.67	1,736.0	16.46	5.592	.5226	.05175	.03685	.7338	1.028
5.111	.002260	67.26	46.68	2,179.0	22.66	7.328	.4801	.05678	.03847	.7086	.8133
5.422	.002258	69.32	52.54	2,760.0	30.78	9.542	.4397	.06096	.03958	.6770	.6453
3.119	.002261	52.54	49.41	2,441.0	30.54	8.561	.3543	.06832	.04012	.6034	.3730
1.384	.002266	34.97	46.88	2,198.0	30.17	7.684	.2486	.07480	.03991	.4659	.1545
.1981	.002267	13.22	44.70	1,998.0	30.37	6.898	.0986	.08280	.03939	.2072	.0154

TABLE IIIb.—PROPELLER B

[With model fuselage]

$\frac{1}{2}\rho V^2$	ρ spec. wt. slugs/cu. ft.	V , veloc- ity, ft./sec.	r. p. s. n	n^2	Thrust, lb.	Torque, lb.-ft.	V/nD	$C_T = \frac{\text{Thrust}}{\rho n^2 D^4}$	$C_P = \frac{\text{Power}}{\rho n^3 D^5}$	Efficiency η	$C_{P1} = \sqrt{\frac{\rho V^5}{P n^2}}$
4.742	0.002261	64.78	24.72	611.1	-0.06074	0.3982	0.8733	-0.000543	0.00746	-0.0636	8.427
4.802	.002256	65.25	26.00	676.0	+ .7521	.7386	.8362	+ .00609	.01252	+ .4068	5.796
4.817	.002254	65.40	27.47	754.6	2.025	1.148	.7940	.01472	.01749	.6685	4.248
4.849	.002252	65.66	28.79	828.9	3.068	1.563	.7599	.02029	.02165	.7123	3.421
4.947	.002256	66.22	30.705	942.8	4.677	2.140	.7190	.02716	.02602	.7506	2.716
4.683	.002248	64.53	32.54	1,059.0	6.721	2.770	.6606	.03487	.03009	.7654	2.044
4.600	.002249	63.97	35.00	1,225.0	9.175	3.501	.6092	.04114	.03287	.7622	1.596
4.713	.002250	64.74	38.20	1,459.0	12.32	4.397	.5650	.04635	.03462	.7562	1.290
4.907	.002235	66.24	42.225	1,784.0	16.53	5.629	.5230	.05120	.03651	.7332	1.036
5.152	.002247	67.71	47.18	2,226.0	22.82	7.401	.4782	.05632	.03823	.7040	.8093
5.523	.002245	70.18	52.99	2,808.0	31.24	9.630	.4415	.06120	.03951	.6835	.6515
2.960	.002248	51.32	49.02	2,403.0	30.37	8.454	.3488	.06940	.04045	.5984	.3571
1.295	.002252	33.92	46.57	2,169.0	30.22	8.082	.2427	.07636	.04278	.4332	.1405
.1926	.002253	13.08	45.94	2,110.0	30.36	8.013	.0949	.07882	.04358	.1716	.0133

TABLE IIIc.—PROPELLER C

[With model fuselage]

$\frac{1}{2}\rho V^2$	ρ spec. wt. slugs/cu. ft.	V , veloc- ity, ft./sec.	r. p. s. n	n^2	Thrust, lb.	Torque, lb.-ft.	V/nD	$C_T = \frac{\text{Thrust}}{\rho n^2 D^4}$	$C_P = \frac{\text{Power}}{\rho n^3 D^5}$	Efficiency η	$C_{P1} = \sqrt{\frac{\rho V^5}{P n^2}}$
4.775	0.002242	65.26	23.81	566.9	-0.05366	0.4997	0.9136	-0.000521	0.01016	-0.4686	7.913
4.881	.002240	66.02	25.31	640.6	.823	.8212	.8692	+ .007082	.01480	+ .4159	5.791
4.940	.002237	66.46	27.19	739.3	2.133	1.354	.8145	.01593	.02118	.6124	4.113
4.966	.002236	66.66	28.61	818.5	3.170	1.717	.7766	.02139	.02428	.6844	3.410
4.988	.002235	66.82	30.58	935.1	4.708	2.248	.7280	.02782	.02781	.7283	2.711
4.640	.002235	64.43	32.24	1,039.0	6.681	2.827	.6656	.03551	.03147	.7511	2.035
4.753	.002231	65.28	35.23	1,241.0	9.315	3.685	.6173	.04154	.03442	.7452	1.614
4.861	.002232	66.00	38.30	1,467.0	12.45	4.623	.5743	.04694	.03650	.7386	1.309
5.067	.002232	67.42	42.09	1,772.0	16.68	5.831	.5337	.05207	.03811	.7294	1.066
5.413	.002231	69.68	47.24	2,232.0	23.05	7.620	.4916	.05712	.03958	.7091	.8519
5.730	.002230	71.67	52.95	2,804.0	31.42	9.620	.4510	.06203	.04060	.6890	.6781
3.126	.002232	52.94	49.24	2,425.0	30.46	8.556	.3583	.06947	.04088	.6090	.3801
1.307	.002237	34.17	46.79	2,189.0	30.41	7.714	.2433	.07667	.04073	.4582	.1449
.1847	.002238	12.85	44.36	1,968.0	30.36	6.520	.0966	.08512	.03827	.2148	.01482

TABLE III d.—PROPELLER D

[With model fuselage]

$\frac{1}{2}\rho V^2$	ρ spec. wt. slugs/cu. ft.	V , veloc- ity, ft./sec.	r. p. s. n	n^2	Thrust, lb.	Torque, lb.-ft.	V/nD	$C_T = \frac{\text{Thrust}}{\rho n^2 D^4}$	$C_P = \frac{\text{Power}}{\rho n^3 D^5}$	Efficiency η	$C_{P1} = \sqrt{\frac{\rho V^5}{P n^2}}$
4.892	0.002260	65.80	25.040	627.0	0.02025	0.5101	0.8758	0.0001765	0.00931	0.01660	7.440
4.911	.002255	66.00	26.365	695.1	.8453	.8411	.8344	.006657	.01388	.4002	5.392
4.965	.002253	66.42	28.125	791.0	2.156	1.329	.7873	.01494	.01928	.6100	3.959
5.007	.002251	66.70	29.510	870.8	3.212	1.690	.7535	.02024	.02229	.6842	3.300
5.055	.002246	67.10	31.475	990.7	4.768	2.227	.7107	.02647	.02588	.7269	2.646
4.709	.002249	64.70	32.965	1,087.0	6.742	2.819	.6543	.03404	.02981	.7471	2.006
4.789	.002249	65.25	36.090	1,302.0	9.349	3.618	.6027	.03943	.03195	.7438	1.578
4.895	.002249	66.00	39.150	1,533.0	12.47	4.509	.5620	.04467	.03381	.7425	1.288
5.061	.002247	67.12	43.100	1,858.0	16.67	5.741	.5192	.04933	.03556	.7202	1.028
5.343	.002246	69.00	48.160	2,319.0	22.99	7.503	.4776	.05450	.03724	.6990	.817
5.654	.002244	71.00	54.120	2,929.0	31.35	9.815	.4373	.05890	.03863	.6666	.644
2.972	.002247	51.40	50.315	2,532.0	30.34	8.760	.3405	.06590	.03981	.5636	.339
1.274	.002249	33.67	48.305	2,334.0	30.38	8.182	.2323	.07144	.04037	.4111	.129
.1934	.002256	13.09	46.408	2,154.0	30.37	7.859	.09403	.07713	.04180	.1735	.013

TABLE IIIe.—PROPELLER E

[With model fuselage]

$\frac{1}{2}\rho V^2$	ρ spec. wt. slugs/cu. ft.	V, velocity, ft./sec.	r. p. s. n	n^2	Thrust, lb.	Torque, lb.-ft.	V/nD	$C_T = \frac{\text{Thrust}}{\rho n^2 D^4}$	$C_P = \frac{\text{Power}}{\rho n^3 D^5}$	Efficiency η	$C_{P1} = \sqrt{\frac{\rho V^2}{P n^2}}$
4.794	0.002315	64.35	24.57	603.5	-0.02024	0.3957	0.8732	-0.000179	0.00732	-0.02135	8.325
4.846	.002310	64.78	25.78	664.9	+ .7844	.7340	.8574	+ .00631	.01235	+ .4278	5.773
4.862	.002310	64.90	27.34	747.5	2.065	1.1800	.7913	.01477	.01767	+ .6614	4.190
4.906	.002309	65.22	28.70	823.4	3.118	1.5430	.7576	.02026	.02098	.7314	3.446
4.950	.002309	65.48	30.58	935.4	4.672	2.0975	.7137	.02670	.02511	.7610	2.713
4.986	.002309	65.72	32.90	1,082.0	6.720	2.7325	.6660	.03322	.02827	.7828	2.153
5.000	.002309	65.80	35.20	1,239.0	9.115	3.414	.6232	.03936	.03085	.7944	1.746
5.072	.002309	66.28	38.36	1,471.0	12.22	4.530	.5762	.04443	.03296	.7768	1.388
5.200	.002308	67.11	42.00	1,764.0	16.28	5.505	.5327	.04938	.03497	.7522	1.109
5.375	.002310	68.22	46.62	2,173.0	22.28	7.095	.4879	.05480	.03652	.7321	.871
5.600	.002310	69.62	52.11	2,715.0	30.54	9.290	.4454	.06014	.03827	.6999	.675
3.070	.002313	51.53	48.73	2,375.0	30.45	8.3075	.3525	.06847	.03908	.6175	.374
1.378	.002315	34.50	45.86	2,103.0	30.30	7.280	.2508	.07690	.03867	.4988	.159
.194	.002319	12.94	43.10	1,858.0	30.25	6.061	.1001	.08672	.03638	.2386	.017

TABLE IV

SURVEY OF VELOCITY THROUGH PROPELLER PLANE, VE-7 MODEL

Left side				Top				Bottom			
Radius, in.	Free stream velocity, ft./sec.	Velocity through propeller plane, ft./sec.	Ratio	Radius, in.	Free stream velocity, ft./sec.	Velocity through propeller plane, ft./sec.	Ratio	Radius, in.	Free stream velocity, ft./sec.	Velocity through propeller plane, ft./sec.	Ratio
2	71.0	35.5	0.500	2	72.0	34.4	0.478	2	70.2	44.3	0.632
4	71.3	57.4	.806	4	70.2	43.2	.615	4	70.3	57.7	.820
6	71.7	68.5	.956	6	71.4	59.8	.838	6	69.5	62.4	.897
8	71.0	69.8	.982	8	72.0	65.8	.913	8	69.3	64.7	.934
10	70.7	70.5	.997	10	71.2	67.8	.952	10	69.5	65.2	.938
12	71.1	71.4	1.005	12	71.3	69.7	.978	12	69.3	66.2	.955
14	70.8	71.3	1.007	14	70.0	69.4	.991	14	71.7	68.4	.954
16	70.8	71.7	1.013	16	70.0	69.8	.997	16	69.6	66.8	.960
18	70.7	71.9	1.017	18	71.6	71.4	.996	18	69.6	67.4	.968
20	70.6	71.6	1.014	20	71.3	72.3	1.014	20	71.3	69.3	.972
22	70.3	71.1	1.012	22	71.4	72.2	1.011	22	71.4	69.7	.976
24	70.6	71.6	1.014	24	71.7	72.6	1.012	24	71.6	69.9	.977
				3	72.4	36.5	.504				
				5	70.1	52.4	.747				

ORDINATES FOR SECTIONS OF PROPELLERS A, B, C, D, AND E

[See fig. 2]

Radius.....	2.70"		5.40"		8.10"	10.80"	13.50"	16.20"	18"
Chamber.....	Upper	Lower	Upper	Lower	Upper	Upper	Upper	Upper	Upper
Radius L. E..	0.39"		0.05"		0.03"	0.02"	0.02"	0.01"	-----
2.5	0.18	-0.17	0.16	-----	0.12	0.09	0.06	0.03	0.01
5	.25	-.25	.23	-----	.17	.13	.09	.05	.02
10	.34	-.33	.30	-.01	.22	.17	.12	.06	.03
20	.41	-.40	.36	-.01	.27	.20	.14	.08	.03
30	.43	-.42	.38	-.01	.28	.21	.15	.08	.03
40	.42	-.41	.38	-.01	.28	.21	.15	.08	.03
50	.41	-.40	.36	-.01	.27	.20	.14	.08	.03
60	.37	-.36	.33	-.01	.25	.19	.13	.07	.03
70	.32	-.31	.28	-.01	.21	.16	.11	.06	.03
80	.24	-.23	.22	-----	.16	.12	.08	.05	.02
90	.15	-.15	.13	-----	.10	.07	.05	.03	.01
Radius T. E..	0.07"		0.03"		0.02"	0.02"	0.01"	0.01"	-----

Stations in per cent of chord. All ordinates in inches.





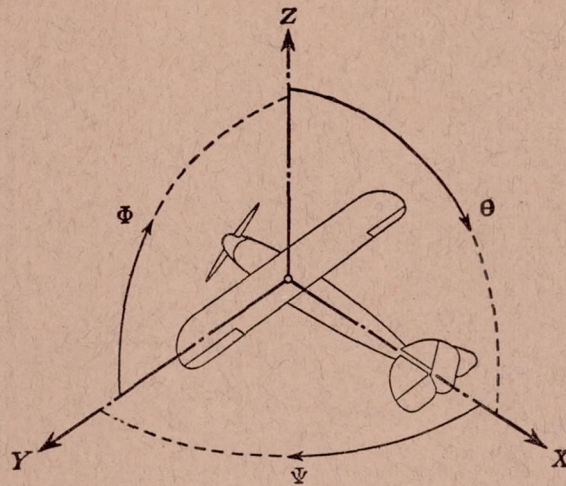

Positive directions of axes and angles (forces and moments) are shown by arrows

Axis		Force (parallel to axis) symbol	Moment about axis			Angle		Velocities	
Designation	Sym- bol		Designa- tion	Sym- bol	Positive direction	Designa- tion	Sym- bol	Linear (compo- nent along axis)	Angular
Longitudinal	X	X	rolling	L	Y → Z	roll	Φ	u	p
Lateral	Y	Y	pitching	M	Z → X	pitch	Θ	v	q
Normal	Z	Z	yawing	N	X → Y	yaw	Ψ	w	r

Absolute coefficients of moment

$$C_L = \frac{L}{qbS} \quad C_M = \frac{M}{qcS} \quad C_N = \frac{N}{qfS}$$

Angle of set of control surface (relative to neutral position), δ . (Indicate surface by proper subscript.)

4. PROPELLER SYMBOLS

D , Diameter.
 p_e , Effective pitch
 p_g , Mean geometric pitch.
 p_s , Standard pitch.
 p_v , Zero thrust.
 p_a , Zero torque.
 p/D , Pitch ratio.
 V' , Inflow velocity.
 V_s , Slip stream velocity.

T , Thrust.
 Q , Torque.
 P , Power.

(If "coefficients" are introduced all units used must be consistent.)

η , Efficiency = $T V/P$.
 n , Revolutions per sec., r. p. s.
 N , Revolutions per minute., R. P. M.
 Φ , Effective helix angle = $\tan^{-1} \left(\frac{V}{2\pi r n} \right)$

5. NUMERICAL RELATIONS

1 HP = 76.04 kg/m/sec. = 550 lb./ft./sec.
 1 kg/m/sec. = 0.01315 HP.
 1 mi./hr. = 0.44704 m/sec.
 1 m/sec. = 2.23693 mi./hr.

1 lb. = 0.4535924277 kg.
 1 kg = 2.2046224 lb.
 1 mi. = 1609.35 m = 5280 ft.
 1 m = 3.2808333 ft.

