

AERO. & ASTRO. LIBRARY

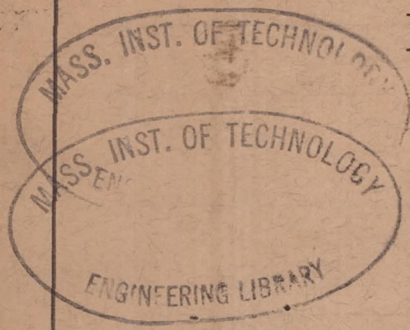

Library, Mass Inst. Tech

**NATIONAL ADVISORY COMMITTEE
FOR AERONAUTICS**



REPORT No. 448

Copy # 23

**IMPROVED APPARATUS FOR THE MEASUREMENT
OF FLUCTUATIONS OF AIR SPEED
IN TURBULENT FLOW**

By W. C. MOCK, Jr., and H. L. DRYDEN



1932

AERONAUTICAL SYMBOLS

1. FUNDAMENTAL AND DERIVED UNITS

	Symbol	Metric		English	
		Unit	Symbol	Unit	Symbol
Length.....	<i>l</i>	meter.....	m	foot (or mile).....	ft. (or mi.)
Time.....	<i>t</i>	second.....	s	second (or hour).....	sec. (or hr.)
Force.....	<i>F</i>	weight of one kilogram.....	kg	weight of one pound.....	lb.
Power.....	<i>P</i>	kg/m/s.....		horsepower.....	hp
Speed.....		km/h.....	k. p. h.	mi./hr.	m. p. h.
		m/s.....	m. p. s.	ft./sec.	f. p. s.

2. GENERAL SYMBOLS, ETC.

<p><i>W</i>, Weight = mg</p> <p><i>g</i>, Standard acceleration of gravity = 9.80665 m/s² = 32.1740 ft./sec.²</p> <p><i>m</i>, Mass = $\frac{W}{g}$</p> <p>ρ, Density (mass per unit volume). Standard density of dry air, 0.12497 (kg-m⁻³ s²) at 15° C. and 750 mm = 0.002378 (lb.-ft.⁻³ sec.²).</p> <p>Specific weight of "standard" air, 1.2255 kg/m³ = 0.07651 lb./ft.³.</p>	<p>mk^2, Moment of inertia (indicate axis of the radius of gyration <i>k</i>, by proper sub- script).</p> <p><i>S</i>, Area.</p> <p><i>S_w</i>, Wing area, etc.</p> <p><i>G</i>, Gap.</p> <p><i>b</i>, Span.</p> <p><i>c</i>, Chord.</p> <p>$\frac{b^2}{S}$, Aspect ratio.</p> <p>μ, Coefficient of viscosity.</p>
--	---

3. AERODYNAMICAL SYMBOLS

<p><i>V</i>, True air speed.</p> <p><i>q</i>, Dynamic (or impact) pressure = $\frac{1}{2} \rho V^2$.</p> <p><i>L</i>, Lift, absolute coefficient $C_L = \frac{L}{qS}$</p> <p><i>D</i>, Drag, absolute coefficient $C_D = \frac{D}{qS}$</p> <p><i>D_o</i>, Profile drag, absolute coefficient $C_{D_o} = \frac{D_o}{qS}$</p> <p><i>D_i</i>, Induced drag, absolute coefficient $C_{D_i} = \frac{D_i}{qS}$</p> <p><i>D_p</i>, Parasite drag, absolute coefficient $C_{D_p} = \frac{D_p}{qS}$</p> <p><i>C</i>, Cross-wind force, absolute coefficient $C_c = \frac{C}{qS}$</p> <p><i>R</i>, Resultant force.</p> <p><i>i_w</i>, Angle of setting of wings (relative to thrust line).</p> <p><i>i_s</i>, Angle of stabilizer setting (relative to thrust line).</p>	<p><i>Q</i>, Resultant moment.</p> <p>Ω, Resultant angular velocity.</p> <p>$\frac{Vl}{\rho u}$, Reynolds Number, where <i>l</i> is a linear dimension. e. g., for a model airfoil 3 in. chord, 100 mi./hr. normal pressure, at 15° C., the corresponding number is 234,000; or for a model of 10 cm chord 40 m/s, the corresponding number is 274,000.</p> <p><i>C_p</i>, Center of pressure coefficient (ratio of distance of <i>c. p.</i> from leading edge to chord length).</p> <p>α, Angle of attack.</p> <p>ϵ, Angle of downwash.</p> <p>α_o, Angle of attack, infinite aspect ratio.</p> <p>α_i, Angle of attack, induced.</p> <p>α_a, Angle of attack, absolute. (Measured from zero lift position.)</p> <p>γ, Flight path angle.</p>
--	---

REPORT No. 448

**IMPROVED APPARATUS FOR THE MEASUREMENT
OF FLUCTUATIONS OF AIR SPEED
IN TURBULENT FLOW**

By W. C. MOCK, JR., and H. L. DRYDEN
Bureau of Standards

NATIONAL ADVISORY COMMITTEE FOR AERONAUTICS

NAVY BUILDING, WASHINGTON, D. C.

(An independent Government establishment, created by act of Congress approved March 3, 1915, for the supervision and direction of the scientific study of the problems of flight. Its membership was increased to 15 by act approved March 2, 1929 (Public, No. 908, 70th Congress). It consists of members who are appointed by the President, all of whom serve as such without compensation.)

JOSEPH S. AMES, Ph. D., *Chairman*,
President, Johns Hopkins University, Baltimore, Md.
DAVID W. TAYLOR, D. Eng., *Vice Chairman*,
Washington, D. C.
CHARLES G. ABBOT, Sc. D.,
Secretary, Smithsonian Institution, Washington, D. C.

Director, Bureau of Standards, Washington, D. C.
ARTHUR B. COOK, Captain, United States Navy,
Assistant Chief, Bureau of Aeronautics, Navy Department, Washington, D. C.
WILLIAM F. DURAND, Ph. D.,
Professor Emeritus of Mechanical Engineering, Stanford University, California.
BENJAMIN D. FOULOIS, Major General, United States Army,
Chief of Air Corps, War Department, Washington, D. C.
HARRY F. GUGGENHEIM, M. A.,
The American Ambassador, Habana, Cuba.
CHARLES A. LINDBERGH, LL. D.,
New York City.
WILLIAM P. MACCRACKEN, Jr., Ph. B.,
Washington, D. C.
CHARLES F. MARVIN, M. E.,
Chief, United States Weather Bureau, Washington, D. C.
WILLIAM A. MOFFETT, Rear Admiral, United States Navy,
Chief, Bureau of Aeronautics, Navy Department, Washington, D. C.
HENRY C. PRATT, Brigadier General, United States Army,
Chief, Matériel Division, Air Corps, Wright Field, Dayton, Ohio.
EDWARD P. WARNER, M. S.,
Editor "Aviation," New York City.
ORVILLE WRIGHT, Sc. D.,
Dayton, Ohio.

GEORGE W. LEWIS, *Director of Aeronautical Research*.

JOHN F. VICTORY, *Secretary*.

HENRY J. E. REID, *Engineer in Charge, Langley Memorial Aeronautical Laboratory, Langley Field, Va.*

JOHN J. IDE, *Technical Assistant in Europe, Paris, France.*

EXECUTIVE COMMITTEE

JOSEPH S. AMES, *Chairman*.

DAVID W. TAYLOR, *Vice Chairman*.

CHARLES G. ABBOT.

ARTHUR B. COOK.

BENJAMIN D. FOULOIS.

CHARLES A. LINDBERGH.

WILLIAM P. MACCRACKEN, Jr.

CHARLES F. MARVIN.

WILLIAM A. MOFFETT.

HENRY C. PRATT.

EDWARD P. WARNER.

ORVILLE WRIGHT.

JOHN F. VICTORY, *Secretary*.

REPORT No. 448

IMPROVED APPARATUS FOR THE MEASUREMENT OF FLUCTUATIONS OF AIR SPEED IN TURBULENT FLOW

By W. C. MOCK, Jr., and H. L. DRYDEN

SUMMARY

This paper describes recent improvements in the design of the equipment associated with the hot-wire anemometer for the measurement of fluctuating air speeds in turbulent air flow, and presents the results of some experimental investigations dealing with the response of the hot wire to speed fluctuations of various frequencies. Attempts at measuring the frequency of the fluctuations encountered in the Bureau of Standards' 54-inch wind tunnel are also reported. The design of the amplifying and compensating equipment for use with the hot wire is treated briefly. In addition, the difficulties encountered in the use of such apparatus and the precautions found helpful in avoiding them are discussed. The work was carried out at the Bureau of Standards with the cooperation and financial support of the National Advisory Committee for Aeronautics.

INTRODUCTION

Theoretical investigations of turbulence such as those formulated by Reynolds (reference 1), by Lorentz (reference 2), and by Burgers (reference 3) emphasize the need for experimental data on the fluctuations of air speed found in turbulent air flow. The most promising instrument for such measurements is the hot-wire anemometer, which we believe

to have been first suggested for this use by E. Huguenard and his coworkers. (Reference 4.) In two earlier papers (references 5 and 6) the equipment developed at the Bureau of Standards has been described, and the application of the equipment illustrated by a study of the effects of turbulence in wind-tunnel measurements. Within the last two years, the equipment has been greatly improved as to uniformity of response to fluctuations of various frequencies. It was felt desirable to describe the improved apparatus and to place on record such parts of our experience as might be valuable to other laboratories engaged in similar investigations.

The paper is divided into four parts, each of which is self-contained and may be read independently. Part I treats the response of the hot-wire anemometer to speed fluctuations, giving a recapitulation of the theory developed in a previous paper, describing methods of compensating for the lag of the wire, and experimental determinations of the performance of the wire and the compensating circuit. Part II deals with the design of amplifiers for use in turbulence measurements. Part III describes improvements in the Bureau of Standards' apparatus made since the publication of references 5 and 6. Part IV gives an account of some experiments on the frequency distribution of the speed fluctuations in a wind tunnel.

REPORT No. 448

IMPROVED APPARATUS FOR THE MEASUREMENT OF FLUCTUATIONS OF AIR SPEED IN TURBULENT FLOW

IN FOUR PARTS

PART I

RESPONSE OF THE HOT-WIRE ANEMOMETER TO SPEED FLUCTUATIONS

GENERAL THEORY

The hot-wire anemometer, as used for measurements of speed fluctuations, consists essentially of a platinum wire, of small diameter and short length, placed in the air stream with its long dimension perpendicular to the direction of the mean flow, and heated to a suitable temperature by means of an electrical current. Fluctuations in the speed of the air stream produce fluctuations in the temperature of the wire and hence in its resistance. The changes in voltage drop across the wire may be amplified by means of vacuum-tube amplifiers, and finally measured by means of a thermocouple-actuated milliammeter indicating the square root of the mean square of their magnitudes. If the changes in resistance are negligible as compared to the total resistance in the heating circuit, so that the current remains constant, the fluctuation in the voltage drop will be proportional to the fluctuation in resistance. For special purposes, such as examination of the wave form of the fluctuations, a cathode ray oscillograph may be used as the final measuring instrument. Vacuum-tube voltmeters may also be used if the fluctuations are periodic and of known wave form, otherwise their use will introduce errors.

Unfortunately for the simplicity of the measurements, the fluctuating voltage drop across the hot-wire anemometer is neither proportional in amplitude nor in phase with the speed fluctuations. When the speed is decreasing rapidly the electrical current heating the wire is unable to supply sufficient energy to raise the temperature of the wire at the required rate. Conversely, when the speed is increasing rapidly, the supply of heat energy possessed by the wire retards its cooling. In other words, the hot-wire anemometer has a lag which causes the fluctuating voltage drop to be less in magnitude and to lag in phase behind the voltage drop which would correspond under equilibrium conditions to the instantaneous speed, by an amount which increases as the rapidity of the speed fluctuation increases.

The theory of the behavior of a hot wire when subjected to speed fluctuations, either periodic or irregular, has been developed in a previous paper (reference 5) and need not be repeated in full here. It suffices to state that the response of the hot wire is characterized by a time constant M , related to the physical properties of the wire and the operating conditions in the following manner:

$$M = \frac{4.2\rho A^2 s (\bar{T} - T_0)}{i^2 r_v}$$

where

T_0 = room or air temperature.

\bar{T} = average temperature of the hot wire.

A = cross-sectional area of the hot wire.

s = the specific heat of air, 0.037 cal. per g per degree C., approximately.

i = the heating current.

ρ = density of the wire, 21.37 g/cm³ for platinum.

r_v = resistivity of the wire at temperature T_0 = approximately 0.000012 ohm-cm, for platinum at the usual room temperature.

For periodic fluctuations the action of the hot wire is to produce a fluctuating voltage drop equal in amplitude to

$$\frac{1}{\sqrt{1 + M^2 \omega^2}}$$

times the amplitude of the fluctuating voltage drop that would correspond under equilibrium conditions to the speed fluctuation, and lagging behind the speed fluctuation, in phase, by the angle, $\alpha = \tan^{-1} M \omega$, where M is the time constant of the hot wire as defined above, and ω is 2π times the frequency of the velocity fluctuations.

For irregular fluctuations, the voltage fluctuation corresponding to the speed fluctuation under equilibrium conditions may be expanded in a Fourier series, the effect on each component of the series computed as

for a periodic fluctuation, and the results added to give the response of the wire.

From the form of the expression for the reduction of amplitude, it is evident that the hot-wire anemometer becomes very insensitive at any but the lowest frequencies. Improvement in the performance in this respect may be obtained by reducing the diameter of the wire used, but even with the smallest sizes, 0.003 to 0.015 mm, the use of which is attended by considerable practical difficulty, the performance remains inadequate if the higher frequencies thought to exist in the speed fluctuations are to be reproduced in their true relation to the lower frequencies.

The performance of a typical hot-wire anemometer (diameter 0.0167 mm) is illustrated by Table I.

TABLE I

Frequency cycles per second	ω	$\frac{1}{\sqrt{M^2\omega^2+1}}$	$\tan^{-1} M\omega$
1	6.3	1.000	0
5	31.4	.992	1.4
10	62.8	.970	7.2
20	125.7	.893	14.1
50	314.2	.636	26.7
75	471.2	.469	51.5
100	628.3	.370	62.0
200	1,256.6	.195	68.3
			78.7

$M=0.004$, $r_s=0.000012$, $\rho=21.37$, $s=0.037$, $\bar{T}-T_0=120^\circ$ C., $A=2.2 \times 10^{-6}$, $i=0.2$ ampere.

COMPENSATION CIRCUITS FOR REDUCING THE LAG ERROR

A graphical correction for the amplitude reduction and phase lag of the hot-wire anemometer is possible (reference 5) if an oscillogram, or similar record, of the fluctuation is available and the fluctuation is small. In practice, however, the complexity of the oscillogram makes such a method so laborious as to be impractical. Furthermore, the condition that the fluctuation be small does not always obtain.

The expressions given for the amplitude reduction and phase lag of the hot-wire anemometer are identical in form with those expressing the magnitude and phase of the current relative to the impressed voltage in a circuit containing inductive reactance and resistance. It should therefore be possible to introduce somewhere in the apparatus associated with the hot-wire anemometer an electrical distortion, having an equal but opposite effect, in such a way as to eliminate the lag errors. This method was suggested in an earlier paper. (Reference 5.)

The method adopted for introducing this compensating distortion consists essentially of the use of a voltage-dividing circuit (fig. 1) made up of an inductance L and a resistance R_1 in series and connected across the load resistor R_L of one of the vacuum tubes in the amplifier in such a manner that the grid circuit of the following vacuum tube is connected across the inductance. In series with the inductance L , and in

that part of the voltage divider feeding the following vacuum tube, is a resistance R_2 used for adjustment of the time constant L/R_2 which must be made equal to the time constant M of the hot wire. Designating by R_0 the resistance of the load resistor R_L in parallel with the internal alternating current resistance of the vacuum tube out of which the circuit works, it is readily seen that the ratio of the voltage applied to the

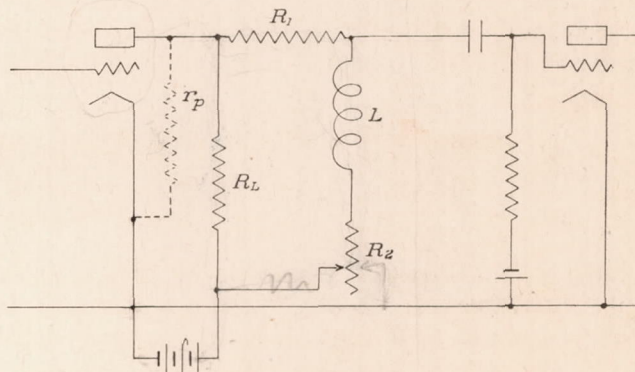

FIGURE 1

grid circuit of the following tube to the voltage drop across the plate resistor R_L is equal to

$$\frac{R_2 + j\omega L}{R_0 + R_1 + R_2 + j\omega L}$$

To give the desired compensation, the ratio should be proportional to $R_2 + j\omega L$, the factor of proportionality not containing ω , and L/R_2 should equal the time constant M of the wire. As explained more fully in reference 5, the sensitivity of the apparatus is reduced by the compensating circuit in the ratio

$$\frac{R_2}{R_0 + R_1 + R_2}$$

and the error in compensation at a given frequency depends primarily on the factor

$$\frac{L}{R_0 + R_1 + R_2}$$

For an error of 1 per cent in amplitude, $\frac{\omega L}{R_0 + R_1 + R_2}$ must be as small as 0.14, or the error factor must be as small as $\frac{0.14}{\omega}$. The frequency at which the error reaches 1 per cent is equal to 0.14 divided by 2π times the error factor.

In 1930 a similar circuit (fig. 2) was described by Ziegler. (Reference 8.) The practical equivalence of this circuit and that in use at the Bureau of Standards is made evident by a consideration of the impedance to alternating currents presented by condensers and inductances. The capacity C across the resistance R_1' (fig. 2) offers an impedance $Z_c = \frac{1}{2\pi fC}$. This impedance decreases with increasing frequency and thus decreases the voltage drop across R_1' , allowing a

greater voltage to be passed on to the grid of the following vacuum tube. The inductance L in the Bureau of Standards circuit offers an impedance $Z_L = 2\pi fL$, which increases as the frequency increases and thus increases the voltage impressed across the grid circuit of the following vacuum tube. The effect in each case is directly proportional to the frequency and the results are equivalent.

By the process used in deriving the corresponding expressions for the inductance type of compensating circuit it may be shown that in Ziegler's arrangement

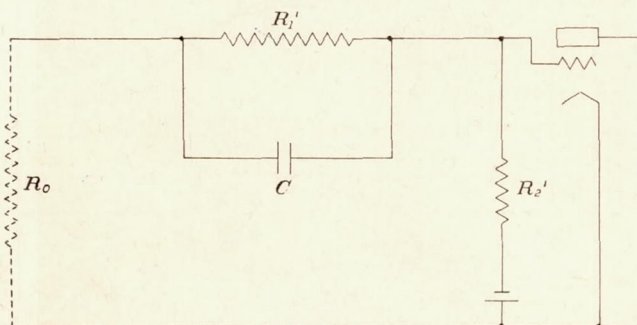

FIGURE 2

the sensitivity is reduced by the compensating circuit in the ratio

$$\frac{R_2'}{R_0 + R_1' + R_2'}$$

the error factor is

$$\frac{CR_1'(R_0 + R_2')}{R_0 + R_1' + R_2'}$$

and the time constant, which must be equal to the time constant of the hot wire is CR_1' , where R_0 is the impedance out of which the system works.

The relative performance of the two circuits may be examined by substituting in the expressions for the attenuation, error, and time constant of the inductance compensation circuit typical values of inductance and resistance as used at the Bureau of Standards, equating the values of attenuation and time constant thus obtained to the equivalent expressions for the capacity compensation circuit, substituting various appropriate values of R_0 and R_1' , and finally solving for C , R_2' and the value of the error factor. This operation is carried out below, and the results presented in Table II.

$$\begin{aligned} L &= 10.87 \text{ henrys.} \\ R_0 &= 100,000 \text{ ohms.} \\ R_1 &= 1,000,000 \text{ ohms.} \\ R_2 &= 3,000 \text{ ohms.} \end{aligned}$$

Attenuation equals

$$\frac{R_2}{R_0 + R_1 + R_2} = 0.00272$$

Time constant equals

$$\frac{L}{R_2} = 0.003623$$

Error factor equals

$$\frac{L}{R_0 + R_1 + R_2} = 0.00000985$$

Equating values of attenuation and time constant thus obtained to corresponding expressions for the capacity compensation circuit,

$$\text{Attenuation} = \frac{R_2'}{R_0 + R_1' + R_2'} = 0.00272$$

$$\text{Compensation} = CR_1' = 0.003623$$

and solving for C , R_2' and the error factor for $R_1' = 1,000$, 10,000, 100,000, and 1,000,000 ohms when $R_0 = 10$ ohms and again when $R_0 = 100,000$ ohms, we obtain the results of Table II.

TABLE II

R_1' ohms	$R_0 = 10$ ohms			
	$C \mu f$	R_2' ohms	error factor	Frequency for 1 per cent error c. p. s.
1,000	3.623	2,755	0.00004560	489
10,000	.3623	27.30	.00001346	1,653
100,000	.03623	272.8	.00001021	2,182
1,000,000	.003623	2,727.4	.00000989	2,252
R_1' ohms	$R_0 = 100,000$ ohms			
	$C \mu f$	R_2' ohms	error factor	Frequency for 1 per cent error c. p. s.
1,000	3.623	275.5	0.003575	6.2
10,000	.3623	300.0	.003292	6.8
100,000	.03623	545.5	.001816	12.3
1,000,000	.003623	3,000.2	.0003381	65.8

Examination of the data thus obtained leads to the following conclusions: First, in order to obtain an error factor comparable with that of the inductance type of circuit, 0.00000985, R_0 must be small, thus precluding the possibility of working the capacity compensation system in the plate circuit of one of the amplifying vacuum tubes; second, R_1' should be large for best results. The fact that the circuit may not be used in a vacuum-tube plate circuit leads to a practical difficulty in that if it is employed ahead of the amplifier, as is the case in Ziegler's apparatus (reference 7), the fluctuating voltage from the hot wire is attenuated by the compensating circuit, and may reach the amplifier at a voltage level near that of the tube noises originating in the first amplifying tube. If this happens, amplification increases the tube noises from the first tube in the same proportion as the fluctuating voltage, and since they are so nearly equal, their separation is difficult. Further, the presence of tube noise may introduce spurious frequencies into the voltage fluctuations. The advantage of a compensating circuit that can be used in the middle of the amplifier is that the fluctuating voltage from the hot wire reaches the first tube unattenuated and therefore at a considerably higher level than the noises originating there. The proportion between tube noises and voltage fluctuation

tuation then remains the same, regardless of any subsequent amplification or attenuation. Compensation following the amplifying apparatus is difficult, practically, because such a system would require the voltage fluctuations to be built up to a level too high to be conveniently handled in the vacuum tubes ordinarily available if the output, after being subjected to the attenuation of the compensation circuit, is to remain large enough to operate any ordinary measuring instrument.

EXPERIMENTAL INVESTIGATIONS OF THE PERFORMANCE OF THE HOT-WIRE ANEMOMETER AND THE COMPENSATION CIRCUIT

The performance of the hot-wire anemometer and the compensating system has been investigated experimentally by two methods.

The first method (reference 5) consisted of placing the suitably mounted hot wire in an air stream and imparting a simple harmonic motion to it by mechanical means, the direction of the motion being parallel to the direction of the air flow. The hot wire was oscillated at several frequencies with amplitudes so chosen that the product of frequency and amplitude, and therefore the maximum speed, remained constant. A detailed discussion of the result obtained from those tests is given in reference 5. Briefly, it was found that over the range of frequencies investigated, 0 to 60 c. p. s., the results showed good agreement with the theory, and the action of the compensating circuit was found to be satisfactory.

In 1931, H. Doetsch and P. V. Mathes (reference 8) made a similar investigation and reported good agreement with the earlier work at the Bureau of Standards.

Attempts to extend this method of investigation to higher frequencies by mounting the hot-wire anemometer on one prong of an electrically driven tuning fork met with failure because the fine platinum wire was broken by the large inertia forces set up when any useful amplitude of oscillation, at high frequency, was obtained.

A less direct but more practical method has been described by Ziegler. (Reference 7.) In this method changes in the electrical resistance of the hot wire are produced by a small alternating electric current of known magnitude and frequency superposed on the direct heating current instead of by fluctuations of air speed. For small changes in resistance, the theory of the response to resistance changes produced by changes in the current is identical with that for resistance changes produced by changes in the rate of cooling. The change in resistance is measured as a function of the frequency, the alternating component of the current in the wire being maintained constant. Some measurements by this method have been made at the Bureau of Standards.

The circuit of Figure 3 was used to introduce the alternating current into the wire and to measure the

resulting changes in the resistance of the wire as a function of frequency. It consists simply of a Wheatstone bridge of which one arm R_1 is the hot-wire anemometer. The battery ($E=12$ volts) in series with the regulating resistance R_b , supplies the necessary heating current to maintain the hot wire at the proper average temperature.

The bridge is first balanced both for direct and alternating current when the hot wire is replaced by a resistor whose resistance is equal to the mean resistance of the hot wire and does not vary with the current. The hot wire is then substituted for this resistor. When the small alternating current is applied, it produces an alternating change in the resistance of the hot wire, unbalancing the bridge. The magnitude of the fluctuation of the resistance of the hot wire may be computed from the voltage drop applied to the amplifier and the sensitivity of the bridge. The equilibrium values may be obtained by direct experiment, measuring the resistance of the wire for different heating

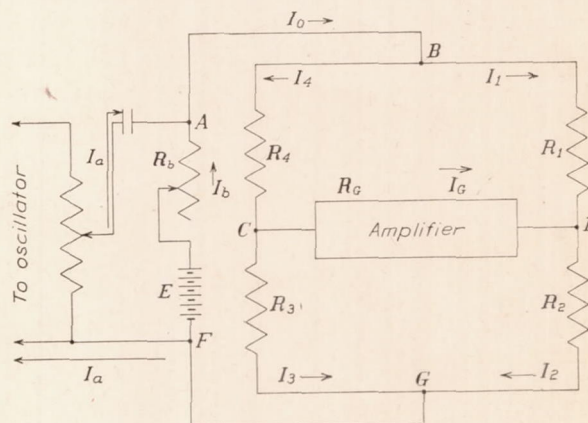

FIGURE 3

currents, using a galvanometer as the indicating instrument for the bridge.

The alternating current was supplied from an audio-frequency vacuum-tube oscillator through a condenser which isolated the oscillator from the bridge, as far as direct current is concerned. The oscillator was a General Radio Co. type 377-B instrument, having a frequency range of 25 to 70,000 c. p. s. with excellent wave form when working into a suitable load impedance, and a power output of about 100 milliwatts, sufficient for the purpose of the tests.

Because of the great bulk of the amplifier and the difference between the capacities of the two sides of the input circuit to ground, it was found desirable to house the amplifier in a metal cage and to place a Wagner ground to the cage across the input terminals. A small slide rheostat (potentiometer) of 25,000 ohms resistance was found satisfactory, the ends of the winding being connected to the two input terminals and the variable point to the cage. The variable point was so adjusted that reversing the bridge current and reversing the amplifier terminals gave the minimum effect.

A number of difficulties were encountered, not mentioned by Ziegler, and perhaps not met with by him because of suitable choice of the bridge constants. It seems desirable to discuss the performance of the combined a. c.-d. c. bridge in a little detail to indicate the nature of the difficulties and how they may be avoided.

Application of Kirchhoff's laws for the continuity of the current at junction points A, B, C, G, and for the voltage relations in circuits BCDB, CGDC, and ABCGFA gives the following seven equations for determining the seven unknown currents, I_a being measured.

$$\begin{aligned} I_b + I_a &= I_0 \\ I_1 + I_4 &= I_0 \\ I_3 + I_g &= I_4 \\ I_2 + I_3 &= I_0 \\ I_4 R_4 + I_g R_g - I_1 R_1 &= 0 \\ I_3 R_3 - I_2 R_2 - I_g R_g &= 0 \\ I_4 R_4 + I_3 R_3 + I_b R_b &= E \end{aligned}$$

Since it is desired to hold the alternating current in the wire constant, and only I_a can be readily measured, the first thing of interest is the relation between I_1 and I_a . Solution of the above equations for I_1 gives

$$I_1 = \frac{(E + I_a R_b) (R_g R_3 + R_g R_4 + R_2 R_4 + R_3 R_4)}{Y + R_g X}$$

where

$$Y = R_1 R_2 R_3 + R_1 R_2 R_4 + R_1 R_3 R_4 + R_2 R_3 R_4 + R_b R_1 R_2 + R_b R_1 R_3 + R_b R_2 R_4 + R_b R_3 R_4$$

and

$$X = R_1 (R_b + R_3 + R_4) + R_b R_2 + R_b R_3 + R_b R_4 + R_2 R_3 + R_2 R_4.$$

R_g , the resistance of the input circuit of the amplifier is quite large as compared with the values of the other resistances in the bridge. Introducing this fact, we find

$$I_1 = \frac{(E + I_a R_b) (R_3 + R_4)}{X}$$

The resistance R_1 of the hot wire is not constant, but fluctuates with the current. Let us place $R_1 = \bar{R}_1 + r$, where \bar{R}_1 is the mean value and the departure r is a function of I_1 . Introducing the value of R_1 in X , we find $X = \bar{X} + (R_b + R_3 + R_4) r$ when \bar{X} is the value of X with \bar{R}_1 substituted for R_1 . Thus

$$I_1 = \frac{(E + I_a R_b) (R_3 + R_4)}{\bar{X} + (R_b + R_3 + R_4) r} \quad (1)$$

Since r is a function of I_1 and also of the frequency, the relation between I_1 and I_a is not independent of the frequency and is far from simple in the general case. Keeping I_a constant does not keep I_1 constant.

However, $\frac{I_a R_b}{E}$ and $\frac{(R_b + R_3 + R_4) r}{\bar{X}}$ will be small if

I_a is small. Treating them as small quantities whose squares and products may be neglected, equation (1) may be written

$$I_1 = \frac{E(R_3 + R_4)}{\bar{X}} + \frac{I_a R_b (R_3 + R_4)}{\bar{X}} - \frac{E(R_3 + R_4)(R_b + R_3 + R_4) r}{\bar{X}^2} \quad (2)$$

The first term in equation (2) is the direct current through the wire which we shall call I_{dc} . The second term is the main alternating current through the wire, proportional to I_a . The third term represents the fluctuation in current through R_1 due to the variation of R_1 . To secure a simple relation between I_1 and I_a , it is desirable to make this last term negligible. The ratio of the last term to the second is

$$\frac{E (R_b + R_3 + R_4) r}{I_a R_b \bar{X}}$$

$$\text{or, } \frac{I_{dc} \left(1 + \frac{R_b}{R_3 + R_4}\right) r}{I_a R_b} \quad (3)$$

Since r and I_a are not in phase, the direct ratio can not be taken. Placing $I_a = \bar{I}_a e^{j\omega t}$ and $r = \bar{r} e^{j(\omega t - \alpha)}$ the ratio (3) becomes

$$\frac{I_{dc} \left(1 + \frac{R_b}{R_3 + R_4}\right) \bar{r} e^{-j\alpha}}{\bar{I}_a R_b} \quad (4)$$

The importance of the choice of suitable values of the bridge resistances in reducing the ratio (3) is best illustrated by two numerical examples.

Assuming the reasonable value of $M = 0.0041$, and a frequency of 25 c. p. s., we will consider first a bridge having the following values of resistances, $R_1 = 7.60$ ohms, $R_2 = R_3 = 7.58$ ohms, $R_4 = 7.60$ ohms, $R_b = 22.44$ ohms, and $\bar{r} = 0.053$ ohms, a 12-volt heating battery being used, and \bar{I}_a made 0.005 ampere. Then,

$$\begin{aligned} I_{dc} &= \frac{(15.18) 12}{911.71} \\ &= 0.1998 \text{ ampere,} \end{aligned}$$

and the ratio (4) of the alternating current caused by the resistance variation to the main alternating current through the hot wire is

$$\frac{0.1998 \left(1 + \frac{R_b}{R_3 + R_4}\right) \bar{r} e^{-j\alpha}}{0.005 R_b} = 0.339 e^{-j\alpha}.$$

Next, consider a bridge having the same direct current through the same hot wire, and the following values of resistance $R_b = 44.52$ ohms, $R_1 = 7.60$ ohms, $R_2 = 7.60$ ohms, $R_3 = 900$ ohms, $R_4 = 900$ ohms, M and ω having the same values as in the first example. Then, it may be shown, that $I_{dc} = 0.1998$ ampere as before. Also, from a consideration of the second term of (2), the alternating current in the wire is increased by a factor of 1.97. The value of \bar{r} is therefore taken to be 0.053×1.97 or 0.104, i. e., as proportional to the alternating current, an assumption which experiment shows to be reasonable when the

alternating current is small as compared to the direct heating current. The ratio of the alternating current caused by the resistance variation to the main alternating current through the hot wire is then $0.096 e^{-j\alpha}$, which is less than one-third the value for the bridge arrangement of the first example.

The current I_1 is very nearly in phase with I_a when r is small, and the resistance variation lags the current I_1 by the phase angle $\tan^{-1} M\omega$ where M is the time constant of the hot wire. Hence α is approximately $\tan^{-1} M\omega$ or for the above examples $\tan^{-1} 0.0041 \times 2\pi \times 25 = \tan^{-1} 0.64$ or 32.6° . Even with the second bridge arrangement, the alternating current due to resistance variation is 8 per cent of the main alternating current at a frequency of 25 c. p. s. With increasing frequency, \bar{r} decreases in magnitude and α increases so that the effect disappears. Hence an experimental procedure which holds I_a constant permits variations of the alternating component of I_1 of approximately 8 per cent.

Solution of the bridge equations for $I_g R_g$ with R_g large leads to the result:

$$I_g R_g = \frac{(E + I_a R_b)(R_2 R_4 - R_1 R_3)}{X} \quad (5)$$

or introducing $\bar{R}_1 + r$ for R_1 , assuming the bridge to be balanced as to \bar{R}_1 , i. e., $R_2 R_4 = \bar{R}_1 R_3$, and neglecting $I_a R_b$ as compared to E and $(R_b + R_3 + R_4) r$ compared to \bar{X} , we find

$$I_g R_g = \frac{E R_3 r}{\bar{X}} \quad (6)$$

Introducing I_{ac}

$$I_g R_g = \frac{I_{ac} R_3 r}{R_3 + R_4} \quad (7)$$

Equation (7) gives the relation between the voltage across the amplifier input and the resistance variation r . It is seen that the sensitivity may be increased by making R_3 large in relation to R_4 . However, this procedure requires R_2 to be increased in order to preserve the balance of the bridge which in turn requires I_1 to flow through a large resistance. This is impractical because of the large battery required to supply the heating current. A good compromise between sensitivity and battery size is obtained when R_3 and R_4 are equal, the sensitivity then being one-half the theoretical maximum.

When designing a bridge for use with both alternating and direct current it is essential to make all resistances as nearly noninductive as is possible. In the instance of R_2 , R_3 , and R_4 this presents no greater problem than that of constructing the resistances according to one of the several methods known to give satisfactory results over the range of frequencies involved, roughly 0 to 10,000 c. p. s. The solution is not so simple in the case of R_1 because this arm of the bridge contains the hot wire, which must of necessity be mounted in the wind tunnel and connected to the

remainder of the apparatus by leads of considerable length. The inductance of these leads may be of great importance.

The alternating current potential across R_1 (main term only) is

$$\frac{R_1(R_3 + R_4)(I_a R_b)}{\bar{X}} = \frac{I_{ac} I_a R_b R_1}{E} \quad (8)$$

and the voltage being measured is, from equation (7),

$$I_g R_g = \frac{I_{ac} R_3 r}{R_3 + R_4} \quad (9)$$

It is evident that any inductive reactance in the R_1 branch of the bridge, such as that due to the inductance L_e of the long leads to the hot wire, will cause the current in the wire to lag behind the voltage (8); in other words, the voltage (8) will lead the current by the phase angle $\tan^{-1} \frac{\omega L_e}{R_1}$. The quadrature voltage component leading the current in the wire will be

$$\frac{\omega L_e I_{ac} I_a R_b}{E} \quad (10)$$

since $\frac{\omega L_e}{R_1}$ is small. At high frequencies, the change in resistance of the wire lags the current in the wire by nearly 90° , and hence is nearly in quadrature. The ratio of the quadrature component due to the inductance of the leads to the measured voltage is therefore approximately

$$\frac{\omega L_e R_b (R_3 + R_4) I_a}{R_3 r E} \quad (11)$$

and the voltages are in opposite phase so that the effect is to reduce the measured voltage.

The magnitude of the effect of lead reactance is shown by the following example.

Assuming as probable values, $R_3 + R_4 = 2,000$ ohms, $R_3 = 1,000$ ohms, $R_b = 85$ ohms, $L_e = 10^{-5}$ henrys, $E = 12$, $\bar{I}_a = 0.005$, $\omega = 6,280$, ratio (11) becomes $\frac{0.00222}{\bar{r}}$ and if $\bar{r} = 0.00222$ which is a reasonable value at the frequency considered, the ratio of the quadrature voltage to the voltage we wish to measure is 1.00. Since the amplifier amplifies and measures the sum of the two voltages, which are in opposite phase, an error of 100 per cent is introduced, the input voltage to the amplifier being reduced to zero.

Equation (11) indicates that the error caused by the inductive reactance of the leads to R_1 may be reduced by decreasing R_b , a remedy that does not meet the requirements for low ratio of alternating current due to resistance variation to main alternating current. (Equation 4.) An alternative remedy is to balance out the effect of the inductance L_e in the R_1 arm of the bridge by one of two ways: (1) the use of a capacity of proper magnitude across R_3 , or (2) the use of an inductance of magnitude equal to $\frac{L_e R_2}{R_1}$ in the R_2 arm

of the bridge. The latter is the easier solution, and the method employed was to mount R_2 on the end of a pair of leads exactly similar to those in the R_1 arm. Then, since $R_1=R_2$, and the inductance in the two arms is equal, the quadrature voltages balance each other.

The alternating current balance of the bridge may be checked experimentally by substituting a resistance in the R_1 branch equal to the resistance of the hot wire, but independent of temperature. The bridge is then balanced to the direct current, in the usual manner, and alternating voltage from the audio-frequency oscillator applied. If no alternating voltage appears across the amplifier input under these conditions, the bridge is balanced with respect to alternating current.

Figure 4 shows the results of a test on the uncompensated hot-wire anemometer in still air. The input voltage to the amplifier is plotted against frequency,

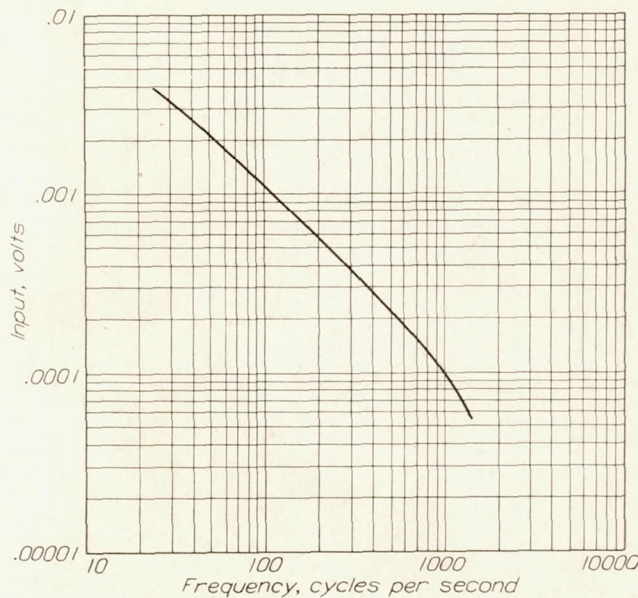

FIGURE 4

the alternating current applied to the bridge being held constant. The procedure followed in making this test was first to adjust the heating current to the proper value by means of R_b . The bridge was then balanced by adjusting R_2 until no direct potential appeared across the amplifier input terminals, using a sensitive direct-current galvanometer as the indicating instrument, since the amplifier was not suitable for direct-current indication. An alternating current of 0.005 ampere was then applied to the bridge, the frequency being varied from 25 to 10,000 c. p. s. Readings of the amplifier output were taken at each frequency. By means of the calibration data, the corresponding input voltages were computed.

The theoretical result of this test would be a curve, such that the input voltage was inversely proportional to $\sqrt{1+M^2\omega^2}$. Over the higher frequency range where $M^2\omega^2$ is large compared to 1, the relation between input voltage and frequency would be expected to be linear

and in the lower frequency range where $M^2\omega^2$ is comparable in magnitude to 1 the curve should be concave downward. The actual result of the test is seen to be identical with the theoretical from 25 to 700 c. p. s. Above 700 c. p. s. the response is less than the theoretical, partly because of some decrease of the amplifier output at the higher frequencies, but largely because the balancing of the inductance of the leads to the hot wire was not perfect, being limited by the sensitivity of the amplifier.

Figure 5 illustrates the results obtained from a test on the hot-wire anemometer working into the compensated amplifier. In this case the wire was placed in the air stream of the wind tunnel. The compensation was set at the value computed from the relation

$$\frac{L}{R_2} = M = \frac{4.2 \rho A_s^2 (\bar{T} - T_0)}{i^2 r_b}$$

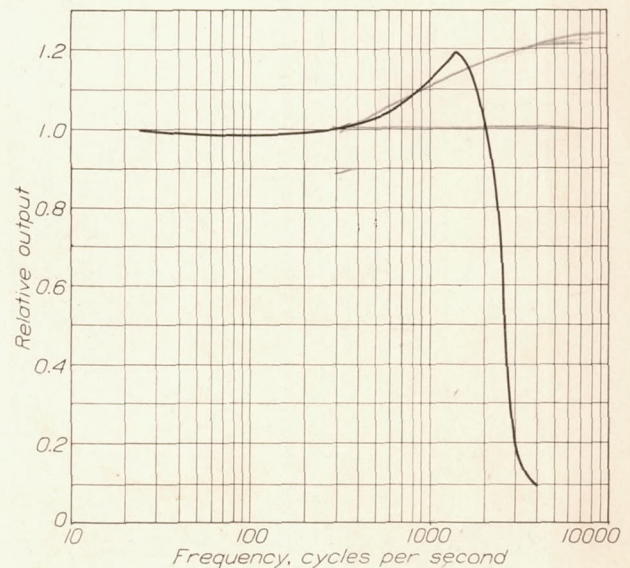

FIGURE 5

From 25 c. p. s. to 430 c. p. s. the compensation brings the output of the hot wire and amplifier combination to within 2 per cent of the ideal value represented by the ordinate 1.0, i. e., the value representing a response independent of the frequency. Above 430 c. p. s. the ratio of the actual to the ideal response increased to a maximum of 1.19 at 1,500 c. p. s. This rise is due to the fact that the coil used in the compensating circuit has unavoidable distributed capacity, as well as the desired inductance, and therefore acts as a tuned circuit resonating at about 1,500 c. p. s. The impedance of an inductance with distributed capacity does not increase directly with frequency, as does the reactance of a pure inductance, but acts rather as though the inductance had been replaced by an equivalent inductance

$$L_e = \frac{L}{1 - \omega^2 LC}$$

where C represents the distributed capacity. For this reason, it is very desirable to reduce the distributed

capacity of the compensating inductance to the lowest possible value and thus reduce the dependence of L_c on frequency.

To summarize, our experiments and those of Ziegler have shown that the theory of the lag of the wire is valid for frequencies up to perhaps 1,000 per second. Verification at higher frequencies is difficult because of the increased sensitivity required and the effects

of the inductance of the several members of the bridge. Since the theory of the lag is shown to be correct, the required performance of the compensating circuit is readily computed. The actual performance may be tested by applying known a. c. voltages of varying frequency. The degree with which the required performance can be met is illustrated in Figure 11, given later.

REPORT No. 448

IMPROVED APPARATUS FOR THE MEASUREMENT OF FLUCTUATIONS OF AIR SPEED IN TURBULENT FLOW

PART II

THE DESIGN OF AMPLIFIERS FOR USE IN TURBULENCE MEASUREMENTS

The fluctuating voltage drop produced by the action of the speed fluctuations in the free stream of a wind tunnel on the hot-wire anemometer is of the order of a few thousandths of one volt and therefore, for convenience in measurement, must be amplified. The vacuum-tube amplifier is the only practical instrument available for this purpose.

Vacuum-tube amplifiers for turbulence measurement must meet several general requirements in the matter of performance. First, they must give sufficient amplification of the available input voltage to operate suitable measuring instruments. Second, they must be free from amplitude distortion; that is, the output must be directly proportional to the input. Third, they should, for a given fixed input voltage, give a constant output, regardless of the frequency of the input voltage, throughout the range of frequencies involved in turbulence measurement.

The first requirement, in the present state of the art at least, means that a suitable amplifier must be one with several stages of amplification. The second requirement means simply that care must be exercised to supply the proper grid and plate potentials to each vacuum tube, so that it will operate on the straight portion of its grid-voltage plate-current curve, and to so choose the tube and its operating conditions that the maximum expected grid voltage swing will neither carry the grid potential from the straight part of the curve nor cause the grid to become positive and draw current. The third requirement, namely, that the amplifier response be independent of frequency in the range of frequencies involved is the most difficult to satisfy, principally because of the first requirement. The construction of a multi-stage amplifier necessitates some method of coupling the tubes together so that the amplified voltage from one vacuum tube may be applied to the grid of the following tube for further amplification. To make this connecting circuit independent of frequency entails considerable difficulty.

There are several interstage coupling systems that may be used over the range of frequencies in which we are interested, and each has certain advantages as well as disadvantages, the discussion of which requires some consideration of the theory of vacuum tubes as amplifiers.

The action of a vacuum tube in amplification is determined by the relations between instantaneous currents and voltages in both input and output circuits. When a steady voltage is impressed on the grid circuit of a vacuum tube, no grid current flows if the grid is negative with respect to the filament. If an alternating voltage is then applied, an alternating current will flow in the grid circuit because of the path offered by the internal grid-filament capacity of the tube, and also in the plate circuit because of the grid-plate capacity. The power thus supplied is dissipated as heat in the resistances of the circuits and must be reduced to the lowest possible level in order to maintain a high efficiency in the amplifier.

The performance of circuits containing vacuum tubes may be computed by assuming that the tube impresses a voltage of μE_g , μ being the amplification factor and E_g the alternating grid voltage, in a circuit consisting of the external impedance Z_0 , and the internal alternating current impedance r_p of the tube under the operating conditions. Hence, the alternating component of the plate current I_p is given by the relation

$$I_p = \frac{\mu E_g}{r_p + Z_0} \quad (10)$$

The alternating voltage E_p across the load circuit is the product of the alternating plate current and the load impedance, that is,

$$I_p Z_0 = E_p = \left(\frac{Z_0}{r_p + Z_0} \right) \mu E_g \quad (11)$$

Since $\frac{E_p}{E_g}$ is the voltage amplification A of the tube and load combination, we may write

$$A = \mu \left(\frac{Z_0}{r_p + Z_0} \right) \quad (12)$$

Equation (12) is of considerable importance in amplifier design in that it shows the effect of load impedance Z_0 , on the voltage amplification. It is seen that Z_0 should be made as large as possible, in order to obtain the maximum gain in voltage. The increase in amplification is rapid until Z_0 becomes some 5 or 10 times as large as r_p . As Z_0 is increased beyond that point, however, comparatively little gain in amplification is obtained.

The four types of interstage couplings that are commonly used are transformer coupling, impedance-capacity coupling, direct coupling, and resistance-capacity coupling. They are illustrated schematically in Figures 6-a, b, c, and d, respectively.

Figure 6a represents the essentials of the common transformer coupled audio-frequency amplifier, which derives its name from the fact that an iron-cored transformer is used to couple the plate circuit of vacuum tube A to the grid circuit of vacuum tube B. The alternating voltage E_g applied to the grid of tube A appears in the output circuit as a voltage μE_g in series with the internal alternating current impedance of the tube r_p , and the primary impedance of the

The advantage of the transformer coupled amplifier is obviously the effect of n in increasing the amplification. The disadvantage, where extreme uniformity of response at a wide range of frequencies is necessary, as in turbulence measurement, lies in the fact that Z_0 , being the impedance of a circuit consisting essentially of inductance and some resistance, is a function of the frequency, varying directly with frequency if the resistance is negligible. Since Z_0 varies with frequency, so does the amplification according to the relation expressed by equation (13). Therefore, if uniform response over any range of frequencies is desired, it can be obtained only by making Z_0 extremely large with respect to r_p at the lowest frequency of the

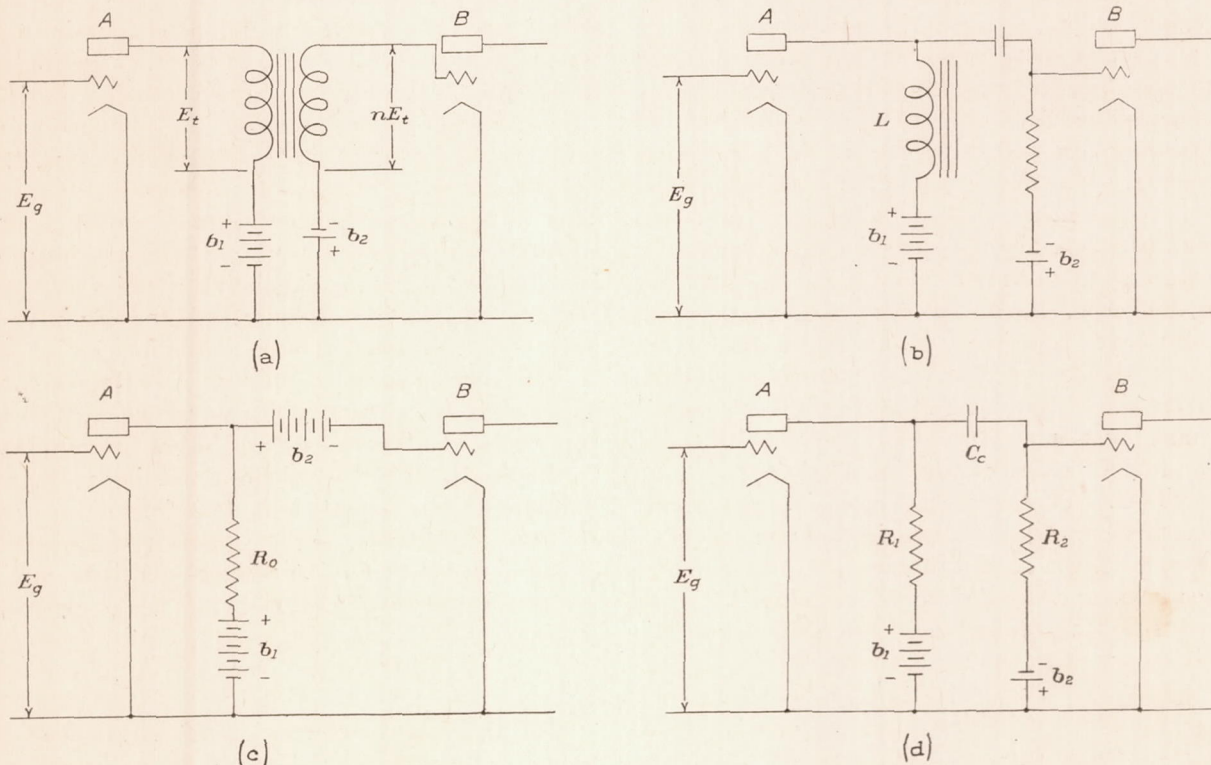

FIGURE 6

transformer T . The voltage E_g thus causes an alternating current to flow through the transformer primary impedance, producing an alternating voltage drop E_t across the transformer primary and inducing an alternating potential nE_t across the transformer secondary, where n is the voltage ratio of the transformer, equal to the turns ratio if the input impedance of tube B is nonreactive and very high, and the transformer is free from all losses and flux leakage. The amplification of tube A and transformer T is then

$$A = \frac{nE_t}{E_g},$$

or n times equation (12); that is,

$$A = \frac{n\mu Z_0}{r_p + Z_0} \quad (13)$$

where Z_0 is the impedance of the transformer primary.

desired range. Since this lowest frequency may be only a few c. p. s., the practical difficulty in constructing a transformer having a large enough impedance for satisfactory operation is very great. A further practical difficulty arises from the fact that the construction of such a transformer requires a primary winding of many turns and hence considerable distributed capacity. This distributed capacity, in conjunction with the capacity between the elements of the associated vacuum tubes, forms a parallel tuned circuit with the transformer inductance. If the resonant frequency of this tuned circuit lies in or near the range of frequencies over which the amplifier is to be used, the impedance Z_0 will be greatly increased at and near resonance with consequent nonuniformity of amplification. If the transformer is so designed that the resonant effect does not occur, the distributed capacity will still make itself felt in the form of a

marked reduction of impedance, and loss of amplification at frequencies above a few thousand c. p. s., because of its shunting effect on the transformer impedance.

From the above discussion, it is seen that the transformer-coupled amplifier experiences considerable difficulty in meeting the requirements for a successful turbulence measuring instrument. As far as is known to us, it is impossible to obtain suitable transformers for such an amplifier.

The impedance-capacity coupled amplifier of Figure 6b may be considered as a special case of transformer coupling in which the voltage ratio n , is unity. It lacks the principal advantage of the transformer coupled type, namely, the possibility of amplification due to transformer voltage ratios greater than one, and possesses the same disadvantages of frequency dependence and distributed capacity effects.

Figure 6c is the basic circuit of the amplifier first used at the Bureau of Standards for turbulence measurements. (Reference 5.) It is a member of a large family of essentially similar amplifiers known as direct coupled. The load impedance Z_0 , is a simple nonreactive resistor and therefore independent of frequency. Hence, theoretically at least, this type of coupling gives uniform action regardless of frequency, and is operable even at zero frequency. Practically, this performance is not obtained because of the shunting effect of the stray capacities of the wiring, and the interelectrode capacities of vacuum tubes A and B. These capacities which, as will be shown later, may be quite appreciable in magnitude, are all in parallel with each other and the load resistor R_0 . Then since the impedance Z_0 of the load circuit consisting of R_0 and C in parallel is at frequency f ,

$$Z_0 = \frac{1}{\sqrt{\frac{1}{R_0^2} + (2\pi fC)^2}} \quad (14)$$

it is at once evident that Z_0 decreases with increasing frequency, and that the amplification factor A is

$$A = \mu \frac{1}{r_p \sqrt{\frac{1}{R_0^2} + (2\pi fC)^2} + 1} \quad (15)$$

The amplification decreases with increasing frequency. The loss in amplification at high frequencies is seen to be a function of the capacity C . Unfortunately, the value of C is comparatively large in the direct coupled amplifier of the type illustrated because of the large capacity to ground of battery b_2 , which is used to maintain the grid of tube B at the proper negative potential with respect to the filament.

In use it was found that the direct-coupled amplifier gave uniform response from zero to a few hundred c. p. s. only. For this reason, and also because of the fact that in the direct-coupled amplifier slight variation of the voltage of any battery, or the constants

of any component of the system, caused amplified shifting of the grid and plate potentials of all the following vacuum tubes, making the amplifier subject to drifting, and difficult of adjustment, the use of the direct coupling was abandoned in favor of resistance-capacity coupling.

The resistance-capacity method of coupling is illustrated by Figure 6d. It differs from the direct coupling of Figure 6c only in that a condenser C_c is placed in the connection between the plate of vacuum tube A and the grid of vacuum tube B, the latter being held at the required negative potential by battery b_2 through R_2 .

The purpose of the condenser C_c , is to insulate the grid of tube B from the positive plate potential of tube A, while allowing the amplified alternating voltage across the load resistor R_1 of tube A to be impressed on the grid of tube B. The use of a large grid battery at a high potential above the filament, such as battery b_2 of Figure 6c is then unnecessary. By doing away with this battery a large portion of the shunting capacity which makes the direct-coupled amplifier unsuitable for use at frequencies greater than 100 or 200 c. p. s., is eliminated with consequent improvement in performance. A further advantage realized by the use of resistance-capacity coupling, in preference to direct coupling, is that the condenser C_c , localizes the effect of variation of battery voltages to the tube or tubes connected to that battery, thereby eliminating the general shift of operating voltages and difficulty of adjustment characteristic of direct-coupled systems.

The disadvantage of resistance-capacity coupling is that C_c is reactive and therefore its impedance is dependent on the frequency. That this disadvantage may be obviated by proper design, and in some particulars even turned to advantage, may be shown from an elementary consideration of the circuit theory.

Neglecting, for the present, the effect of the vacuum-tube interelectrode capacities, the load impedance of a resistance-capacity coupled amplifier consists of R_1 (fig. 6d) in parallel with the circuit formed by R_2 with C_c in series. The alternating grid voltage for vacuum tube B is taken from across R_2 . At low frequencies, where the reactance of C_c is large compared to the resistance of R_2 , that part of the alternating voltage across R_1 which is impressed on the grid of vacuum tube B is small, being zero at zero frequency. As the frequency is increased the reactance of C_c decreases, and when it becomes negligible compared to R_2 the maximum amplification results. The amplification is then independent of frequency and the load impedance of tube A is essentially equal to the resistance of R_1 and R_2 in parallel.

From the above it follows that two items must be considered in the design of the coupling circuit, namely, C_c must be large so that good amplification

may be obtained at low frequencies, and R_2 should be large in proportion to R_1 so that the load impedance of vacuum tube A and hence the amplification may be as high as possible.

Unfortunately, the use of a high capacity at C_c and a high resistance at R_2 also results in a circuit of large time constant $C_c R_2$. If a momentary surge or overload of the amplifier causes the grid of tube B to become positive the amplifier will become inoperative, or "block" for a length of time equal to that required for the positive charge to leak off from C_c through R_2 . The time required for this leakage is proportional to the time constant of the coupling circuit. To reduce

lected in the discussion of coupling condenser and grid resistor size. Here it is the magnitude of the unavoidable interelectrode capacities, and the somewhat avoidable stray capacity between grid, plate, and filament wiring that controls the performance.

Figure 7a is the simplified schematic diagram of a 2-stage resistance-capacity coupled amplifier, with the interelectrode capacities shown as dotted lines. Let us investigate the effect of these capacities on the performance of the amplifier at high frequencies.

If we assume that the mean grid potentials of vacuum tubes A and B are negative so that the grid to filament resistances of the tubes are high, and that E_g ,

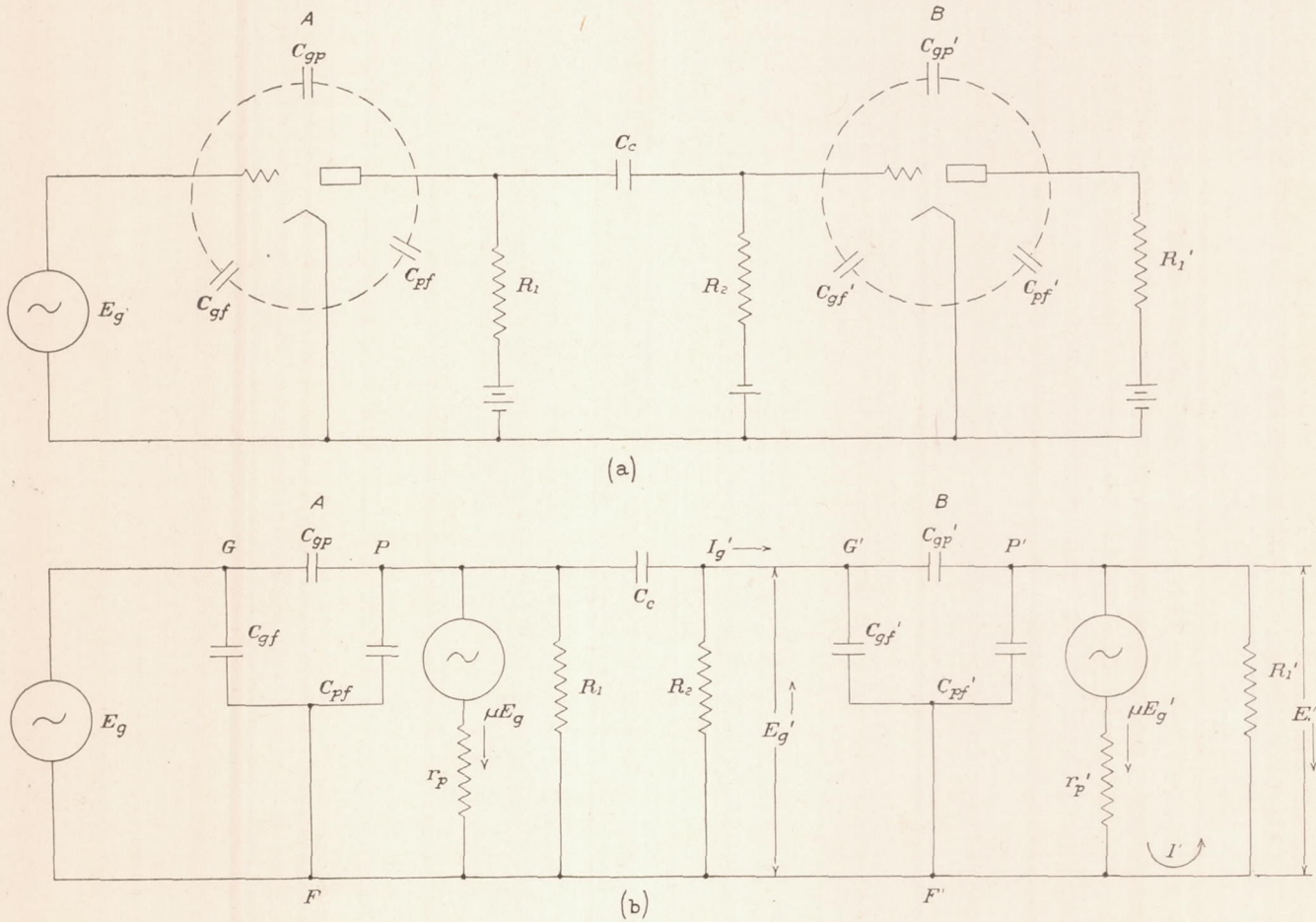

FIGURE 7

this effect to a practical minimum, it is necessary to reduce the time constant either by reducing C_c with resultant loss of amplification at low frequencies, or by reducing R_2 with consequent loss of amplification at all frequencies. The latter alternative, if employed, necessitates the use of a large number of stages in order to obtain the desired amplification, which leads to serious practical difficulties. We are therefore forced to reduce C_c , fixing its value to obtain a compromise between loss of amplification at low frequencies and the degree of sluggishness to be tolerated in the amplifier.

The response of a resistance-capacity coupled amplifier to high frequencies is determined by factors neg-

the applied alternating grid voltage, is small, we may represent the circuit of Figure 7a by the equivalent network of Figure 7b. E_g represents a small alternating input voltage; G, P, and F the grid, plate, and filament, respectively, connected by the interelectrode capacities C_{gf} , C_{gp} , and C_{pf} ; r_p the internal alternating-current impedance of the vacuum tube; R_1 the plate-circuit load resistor; C_c the coupling condenser; and R_2 the grid-circuit resistor of the following tube. The amplifying action of the tube is represented by the alternating voltage μE_g , introduced into the plate circuit in series with r_p . Since the plate current increases as the grid becomes more positive, μE_g is in opposite phase to E_g .

The exact solution of the network of Figure 7b requires the solution of 17 simultaneous equations and will not be given here. The most important effect with many types of vacuum tubes is due to the shunting effect of the network to the right of R_2 , especially to the current flowing in the condenser C_{gp}' . The voltage across this condenser is readily seen to be $E_g' + E'$ where E' is the voltage across the plate resistor R_1' of the second tube. In computing E' for an amplifier used at audio-frequencies, it is permissible as a first approximation to neglect the current flowing through C_{gp}' and C_{pf}' in comparison with I' , since at audio-frequencies the impedances of the interelectrode capacities are large compared with the rest of the network. Then, considering the circuit farthest to the right,

$$I' = \frac{\mu E_g'}{r_p' + R_1'}$$

and

$$E' = I' R_1' = \frac{\mu R_1'}{r_p' + R_1'} E_g'$$

The voltage across the condenser C_{gp}' is therefore

$$E_g' \left(1 + \frac{\mu R_1'}{r_p' + R_1'} \right)$$

or since $\frac{\mu R_1'}{r_p' + R_1'}$ is the voltage amplification A of tube B, $E_g' (1 + A)$. The current flowing through C_{gp}' is therefore $j 2 \pi f C_{gp}' E_g' (1 + A)$.

The voltage applied to the network to the right of R_2 is E_g' . Hence the apparent impedance of the condenser C_{gp}' is

$$\frac{1}{j 2 \pi f (1 + A) C_{gp}'} \quad (16)$$

or the effect is as if the capacity of this condenser were increased by the factor $(1 + A)$.

An exact solution of the network would give a still lower shunting impedance because of the effects of C_{gs} , C_{pf} , C_{pv}' , C_{gp} , and C_{gs}' . C_{pv}' , C_{gs} , C_{pf}' , and C_{gs}' are approximately fixed for any conventional assembly of commercially available tubes and associated components, $C_{pf} + C_{gs}$ being of the order of $30 \mu\mu f$. With $R_1 = 250,000$, a capacity of this magnitude produces a one per cent reduction of the effective plate impedance at a frequency of 3,010 cycles per second, account being taken of the fact that the shunting current is in quadrature with the plate current. With $R_1 = 100,000$, a 1 per cent reduction occurs at a frequency of about 7,540 cycles per second.

When the effects of $(1 + A) C_{gp}'$ are included, we find that frequency errors become large at still lower frequencies. Consider the two amplifiers which have been used at the Bureau of Standards. In the first using UX240 tubes with $R_1 = 100,000$ ohms, C_{gp} is about $10 \mu\mu f$ and A about 20. The effective shunting capacity is $21 \times 10 + 30 = 240 \mu\mu f$. Appreciable errors are introduced at frequencies as low as 900 cycles per second. In the second using the UY224 screen-grid

tubes, with $R_1 = 250,000$ ohms, C_{gp} is only $0.015 \mu\mu f$, and A about 80. The effective shunting capacity is about $80 \times 0.015 + 30 = 31.2 \mu\mu f$. Appreciable errors are introduced only above a frequency of about 2,860 cycles.

The calculations given above correspond fairly well to the actual performance of the two amplifiers. The effect of the shunting capacity is frequently overlooked in the design of resistance-capacity coupled amplifiers.

Another factor having an important effect on the performance at high frequencies as illustrated in part in the preceding calculations is the relation between the shunting capacity and the external plate impedance. If, at a certain high frequency C_s , the shunting capacity has 10 times the impedance of R_1 , its effect will be much less than if, at the same frequency, and with the same shunting capacity, R_1 is increased until its impedance is, say, one-half that of C_s . The effect is further complicated in practice because increase in R_1 will cause increased amplification, according to the relation expressed by equation (12), which in turn results in increased effective shunting capacity, making the difference between the impedance of C_s and the impedance of R_1 still smaller than if R_1 alone had been increased. The modern practice of using very high values of R_1 in order to obtain high amplification per stage must therefore be avoided if good uniformity of response over a wide range of frequencies is necessary. Conversely, if unduly low values of R_1 are employed, in an effort to improve the range of uniform response, the amplification per stage will be so reduced that the number of stages necessary to obtain the required amplification may become excessive.

The objection to a large number of stages is two-fold. First, the difficulty in operation and adjustment of the complete amplifier increases much faster than the number of stages. Second, the actual improvement in uniformity of response obtained may be of slight consequence, even though the performance of each individual stage is improved, because the addition of each similar stage amplifies the nonuniformity of the previous stages. For example, if we have a 2-stage amplifier giving a voltage gain of 100 per stage at some low frequency and 50 per stage at 10,000 c. p. s., the over-all gain of the two stages at the low frequency will be 10,000, and at 10,000 c. p. s., 2,500. If we then reduce R_1 with the object of improved performance, until the voltage gain per stage becomes 10 at the low frequency and 7.5 at the high frequency of 10,000 c. p. s., it will be necessary to use four stages to obtain the same over-all gain at the low frequency as in the previous instance, and the over-all gain at 10,000 c. p. s. will be 3,160. The over-all performance is seen to be improved slightly but not to the same extent as the performance of the individual stages, and probably not enough to compensate for the operational difficulties introduced by the addition of two stages.

REPORT No. 448

IMPROVED APPARATUS FOR THE MEASUREMENT OF FLUCTUATIONS OF AIR SPEED IN TURBULENT FLOW

PART III

IMPROVEMENTS IN THE BUREAU OF STANDARDS APPARATUS

The assembly of equipment at the Bureau of Standards for measurement of turbulence consists of five parts: (1) The wire itself; (2) a Wheatstone bridge for accurate measurement of the resistance of the wire at room temperature; (3) an apparatus with suitable switching arrangements for supplying the wire with heating current, measuring the heating current, measuring the voltage drop across the wire at various air speeds for calibration purposes, and finally transferring the fluctuating voltage drop across the wire to the amplifier input; (4) a suitable amplifying system, including the requisite compensation for the amplitude reduction and phase angle lag of the wire; and (5) a final measuring instrument. The earlier forms of the apparatus are described in references 5 and 6; it is assumed that the reader is familiar with them. Those references also give in detail the method of calibration and the method of computing the magnitude of the speed fluctuation.

THE WIRE

The wire itself has undergone little modification since its first use at the Bureau of Standards. It is generally a platinum wire about 0.75 to 1.0 centimeter in length and 0.017 millimeter in diameter, electrically welded to a suitable mounting. Some of the first hot wires were soldered to their mountings but this practice was soon abandoned because of the uncertain contact between wire and support. The welds joining the platinum wire to the prongs of the supports should be inspected with a low-power microscope, or a good jeweler's eyeglass. A good uniform weld is easily identified. No other kind will be found satisfactory.

It has been found advisable to anneal each new wire before use by passing sufficient current through it to cause it to glow a dull red. If the wire is to be used tightly stretched, as when working in the boundary layer of a flat plate or other body, this annealing process should be conducted with the wire tight but must not be continued for more than a few minutes. Undue prolongation of the annealing of such a wire usually leads to a greatly shortened life. The wire when heated tends to soften, as is desired, but tension tends to stretch and harden it again. If the annealing

is continued for a long time, the wire becomes considerably elongated and weakened, breaking soon after being put in service. Measurements of the turbulence in the free stream of the wind tunnel do not require that the wire be under tension; therefore wires for this use may be annealed for longer periods without detrimental effect on their life. Fifteen to thirty minutes is probably quite sufficient for proper annealing.

Proper annealing tends to reduce the magnitude of the changes in the room-temperature resistance of the wire which often take place during the course of a set of observations. Thus, the accuracy of the data obtained is increased and the labor of the computations decreased. Since the resistance of the wire is seldom the same after a run as before, it is advisable to measure it carefully immediately before and after completing the observations.

The age of the wire has been found to have an effect on the results obtained. In one case the use of a wire several months old increased the readings several per cent in comparison with those obtained with a new wire. This action is believed to be due to some change in the character or condition of the surface of the wire, perhaps accumulation of dirt, and may not occur everywhere. It is believed to be the best policy to change the wire frequently and avoid any possibility of this effect.

EQUIPMENT FOR MEASURING MEAN VOLTAGE DROP

The third item of the equipment, the heating-current measurement, control, and voltage-drop measurement apparatus, together with the switching circuits, remains the same as that described in previous reports (references 5 and 6), except that the mechanical arrangement has been considerably improved, with resultant increase in convenience of operation.

THE AMPLIFIER

The amplifier has undergone several modifications since the publication of references 5 and 6. The amplifier described in reference 5 consisted of four stages, using UX240 vacuum tubes, direct coupled as in Figure 6c, and an output stage consisting of one UX171 vacuum tube. While this arrangement proved

usable over the range of frequencies between zero and one or two hundred c. p. s., it was subject to drifting, and difficult to maintain in the proper operating condition. It sometimes happened that the change in calibration of the amplifier during the course of taking a set of observations was so great that the observations had to be discarded. For these reasons the use of this amplifier was discontinued and the amplifier described in reference 6 was constructed. This amplifier differed from the former principally in the use of resistance-capacity coupling instead of the original direct-coupling system. This change resulted in a great improvement in the constancy of performance of the apparatus by eliminating the drifting and general uncertainty of operation over any extended period of time. Furthermore, the range of frequencies over

In 1930 work was started on an improved amplifier. The schematic circuit diagram of the fifth and final arrangement (fig. 8) indicates that basically it is the same as the amplifier of reference 6. The differences are in the details and components employed.

The first difference of note is the use of the more modern UY224 tetrode vacuum tubes in place of the earlier UX240 triodes. These tubes have two advantages: First, the voltage amplification factor is much higher, permitting a voltage amplification per stage of 60 to 80 under the conditions of operation existing in the present amplifier; second, due to the use of a screening, or shielding grid between the control grid and plate, the internal capacity between grid and plate is reduced from the 10 μmf of the UX240 type to 0.015 μmf , resulting in a reduction of the total shunting

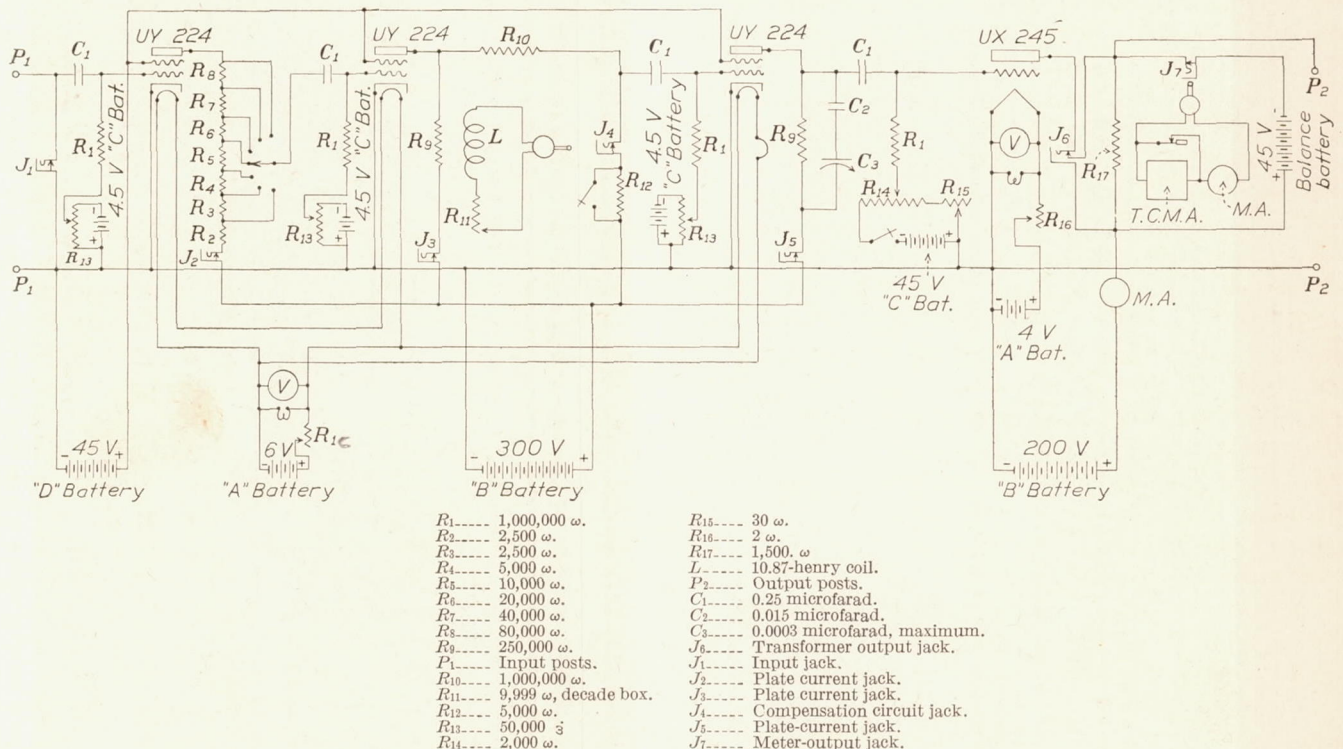

FIGURE 8.—Circuit of audio-frequency amplifier for turbulence measurement

which uniform response was obtained was substantially increased, because of the reduction in shunting capacity effected by dispensing with the large grid bias battery. (See b_2 of fig. 6c.) The coupling capacities used were 2 μf mica condensers of high quality, and together with the 1 megohm grid resistors formed a coupling circuit having a time constant of 2 seconds. This large coupling capacity permitted uniform response to frequencies as low as 1 c. p. s. or less, but the 2-second time constant caused some inconvenience because of the long time required for the amplifier to unblock after being subjected to a momentary overload, such as often occurs in the use of the apparatus. The tubes employed were the UX240 type, and the voltage amplification per stage was about 20.

capacity from 240 μmf , to 31.2 μmf with consequent increase in the range of uniform response. A further improvement in operation resulting from the use of the UY224 vacuum tube, with its considerably higher voltage amplification is that the number of stages exclusive of the output stage has been reduced from four to three. This reduction in the number of stages, together with the use of stages having superior individual performance with respect to uniformity of response, results in still greater over-all improvement in uniformity.

In the 4-stage amplifiers of references 5 and 6, control of the over-all amplification was obtained by means of taps on the plate resistor of the first tube and a switching arrangement for cutting out one stage. In the present 3-stage amplifier the amplification control

consists of a greater number of taps on the plate resistor of the first tube, and no provision is made for cutting out a stage of amplification. The plate-resistor taps are so arranged that each step reduces the amplification to half that of the previous step. There are 7 such steps in the control and the amplification may be varied over a range of 64 to 1.

Another important modification in the present apparatus consists of the substitution of coupling condensers of $0.25 \mu f$ capacity for those of $2.0 \mu f$ previously used. This change results in nonuniformity of response at frequencies below 25 c. p. s.,¹ but increased uniformity of response at the higher frequencies because of the reduced bulk and stray capacity of the condensers. Also, the performance with respect to blocking is greatly improved, since with 1-megohm grid resistors the time constant of the coupling circuit has been reduced to 0.25 second from the 2.0 seconds of the previous amplifier.

The input of the earlier amplifiers (references 5 and 6) was directly to the grid of the first vacuum tube. In the present amplifier (fig. 8) this has been changed by the insertion in the first grid circuit of a condenser of the same capacity as the coupling condensers. This change increases the ease of operation by insulating the grid of the first vacuum tube from the hot wire as far as direct current is concerned, making exact balancing of the direct current voltage drop across the wire less necessary than before. In the previous amplifiers any unbalance in the direct current voltage drop was transmitted directly to the grid of the first tube, changing the grid voltage thereof, and hence changing the operating conditions of the tube. In the presence of large speed fluctuations, it is difficult to obtain exact balance of the direct current voltage drop, therefore the use of the condenser input has a practical advantage in that it confines any error resulting from incorrect balance to the measurement of the mean voltage across the wire, avoiding further errors due to changes in the condition of operation of the amplifier from that for which the calibration was made.

The UX171 output vacuum tube used in the earlier amplifiers has been replaced in the newer equipment by the UX245 type. This tube was chosen because of its higher transconductance; that is, a greater change in plate current for a given change in grid voltage. Since the measuring instrument generally used is a current-measuring device, this change results in an increase in the sensitivity of the output stage of the amplifier. Further increase in the sensitivity of this stage has been secured by abandoning the use of a potentiometer across the balancing battery to adjust the voltage necessary to balance out the direct-current potential drop across the plate resistor of the output tube. This direct-current potential drop must be balanced

in order that the a. c. milliammeter shall read only the alternating current, but the use of a potentiometer across the balancing battery introduces resistance in series with the measuring instrument and reduces the sensitivity. In the improved amplifier this effect is avoided by choosing a suitable balancing voltage and then adjusting the voltage drop across the output tube plate resistor until it is equal to the balancing battery voltage. The adjustment is made by changing the plate and grid voltages of the output tube. Fortunately, it is found that if the balancing-battery voltage is 45 volts and the plate voltage 200 volts, proper operating conditions are obtained when the plate current of the output tube is adjusted to the 30 m. a. necessary for balance.

Vacuum-tube amplifiers while essentially simple in principle, require constant vigilance to insure satisfactory operation. Constancy of calibration is seldom attained. It is most closely approximated when constant watch is kept on the voltage of all batteries associated with the amplifier. The amplifier must in general be calibrated before and after every set of observations, and the simplest method is to apply a known voltage to the input, under standard conditions, and measure the output current. The amplifier used at the Bureau of Standards is provided with a 5,000-ohm resistor, R_{12} of Figure 8, in series with the compensating circuit, and normally shortcircuited by a switch. When it is desired to calibrate the amplifier the compensating coil and resistance L and R_{11} , are removed from the circuit and the shortcircuiting switch across R_{12} opened. The amplification control R_2 to R_3 , is then set on the fourth step, a resistance of 2 ohms placed across the amplifier input, an alternating current of 2 milliamperes of frequency 500 c. p. s. passed through this resistance, and the output current read. The output current normally obtained is about 3 milliamperes with the present amplifier. If the output is found to be below normal the voltage of all batteries is checked. If no low voltage is found the next step advisable is a check on the operating conditions of each of the three screen-grid tubes. This check is made by inserting a milliammeter in each plate circuit in turn and noting the plate current. A voltmeter and a potentiometer are then connected so that a known grid voltage may be applied to each tube and a curve of plate current versus grid voltage obtained under the conditions of plate and screen-grid voltage and plate-resistor resistance existing in that stage. If the operating plate current as first measured lies within the straight portion of the curve, the stage is in the proper operating condition. If it does not, the trouble is localized and the individual components must be examined. Since these are few in number the trouble is usually easily located. The usual sources of trouble are the plate resistor of the stage under consideration and the coupling condenser of the preceding stage.

¹ The computed error is less than 5 per cent at 10 cycles per second.

Considerable difficulty has been experienced in obtaining suitable plate resistors. It is found that their resistance sometimes increases greatly with age, often becoming extremely high. If this happens, the operating conditions in the stage are upset with consequent loss of amplification. Less frequently the coupling condensers give trouble due to leakage. Any current leakage through the coupling condenser flows through the grid resistor of the following stage, producing a voltage drop tending to make the grid more positive, thus disturbing the operating conditions of the tube. In extreme cases the grid voltage may be so changed that the tube becomes saturated, because of insufficient negative grid voltage, and altogether ceases to amplify. The coupling condenser following the compensation circuit is the one most likely to give trouble because it is subjected to almost the full 300 volts of the plate battery, whereas the other coupling condensers are at a voltage lower than 300 volts by the voltage drop through the plate resistors. The use of the highest grade condensers available is strongly recommended. Infrequently the above examination of the defective stage will disclose no faults in the components. If this is the case the tube itself is probably defective and must be replaced. Faulty tubes, however, are quite rare according to our experience. Some considerable differences may be noticed between the characteristics of tubes nominally of the same type. This is especially true of the UY224 tetrodes, but if care is taken to adjust the grid voltage to the proper value for best operation they will generally be found to give the same performance.

Another item in the amplifier that sometimes gives trouble is the imperfection of wire connections. Whenever possible, all connections should be soldered with a good rosin flux solder. Acid or paste fluxes should never be used because of the corrosion and leakage caused by spattering of the flux when heat is applied. Those connections, such as switches, jacks, and vacuum-tube sockets, which may not be soldered must be frequently inspected and cleaned.

COMPENSATION CIRCUIT

The arrangement of the compensation circuit has been changed slightly from that of the earlier amplifiers. Reference to Figure 8 shows that the compensating inductance and resistance L and R_{11} , are not placed directly in the plate circuit of the vacuum tube in series with the plate resistor, as in the previous amplifiers, but, together with the one megohm resistance R_{10} , form a voltage dividing circuit in parallel with the plate resistor R_9 . This system is essentially the same as the earlier one of inserting L and R_{11} in series with R_9 so that R_9 performs the function of R_{10} , but offers the advantage that R_{10} may be made as large as desired, with consequent reduction of the phase error of the circuit (reference 5), without materially

affecting the amplification of the tube preceding the compensating circuit. In the original arrangement, since the plate battery voltage is fixed by practical considerations R_9 , which also acts as R_{10} , may not be increased indefinitely without reduction of the amplification because of the reduction of the plate voltage as R_9 becomes larger. This reduction in the amplification takes place before R_9 has become as large as might be desired from the standpoint of reducing the errors of compensation.

The compensating inductance L , used in the present equipment is the result of extended efforts to improve the action of the former coil. Reduction of the distributed capacity was the major problem involved, and the solution adopted consisted of winding the coil in three equal sections separated somewhat and connected in series. The finished coil has a length to diameter ratio of about 1.0, an inductance of 10.87

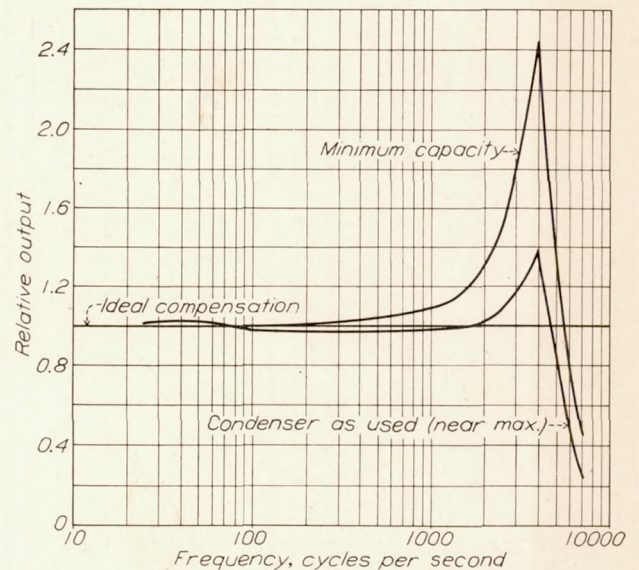

FIGURE 9.—Effect of variable condenser across third tube-load resistance on compensation

henrys, and a resistance of 713 ohms. This coil was found to have sufficient distributed capacity to cause resonance at 4,000 c. p. s., whereas the coil formerly used resonated at 1,500 c. p. s., a considerable improvement even in view of the fact that the inductance of the coil is some 5 per cent lower than that of the original coil.

The presence of the resonant frequency in the range of frequencies over which measurements were desired led to a further modification in the new apparatus not found in the old. This modification is the addition of the shunting condensers C_2 and C_3 (fig. 8), across the plate resistor of the last tube but one. The purpose of these condensers is to introduce a reduction of response at the high frequencies to compensate for the increase in impedance of the compensating coil at and near the resonant frequency. The first condenser C_2 , in series with the variable condenser C_3 , is merely

a protective device. Since the plate current of the next to the last tube is 0.001 ampere and the plate resistor has a resistance of 250,000 ohms, a voltage drop of 250 volts exists across the plate resistor. If the plate resistor is accidentally short-circuited, as has happened during adjustment when C_3 alone was used, the grid of the last tube is subjected to a transient voltage change of 250 volts, with results that are sometimes disastrous. For this reason the condenser C_2 was inserted in series with C_3 to prevent accidental short circuiting of C_3 from short circuiting the plate resistor.

By careful adjustment of the capacity of the shunting condenser C_3 it was found possible considerably to improve the action of the compensating circuit. Figure 9 presents the results of tests with two condenser settings. The horizontal line of ordinate 1.0 represents the ideal of uniform response of the hot wire plus compensated amplifier. The curve labeled "minimum capacity" is the response obtained when the variable capacity C_3 is set at its minimum value. The curve

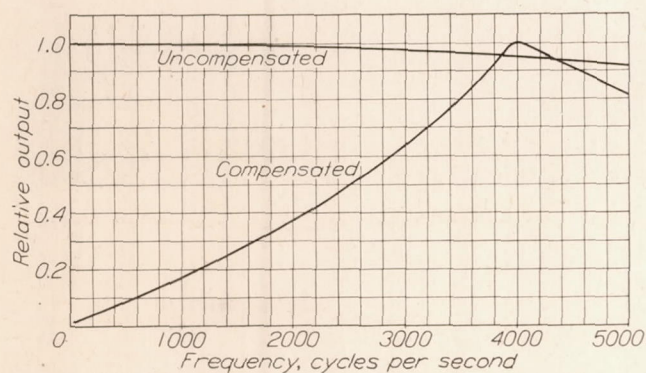

FIGURE 10.—Frequency characteristic of amplifier alone. In each instance the curve is plotted on the basis of maximum output=1.0. The actual maximum output compensated is 121.5 times the uncompensated maximum output

marked "condensers as used" is the best condition obtained as a result of several trial settings of C_3 . With the condenser set at minimum the response is within 2 per cent of the ideal from 25 c. p. s. to 300 c. p. s., an improvement over the previous amplifiers and compensators, but with the condenser set as used, the response is within 2 per cent of the ideal from 25 c. p. s. to 2,000 c. p. s., a very considerable improvement in performance.

The curves of Figure 7 were made by applying a known alternating voltage to the amplifier, measuring the output at various frequencies, and multiplying by $\frac{1}{\sqrt{1+M^2\omega^2}}$ the amplitude reduction factor of the hot wire. Therefore, they represent the combined performance of the hot wire and the compensated amplifier. Figure 10 shows the performance of the amplifier alone; that is, without the effect of the hot wire. It is seen that the response of the uncompensated amplifier is within 2 per cent of uniform from 25 to 3,000 c. p. s. and falls off only 8 per cent at 5,000

c. p. s. The second curve shows the output of the compensated amplifier, plotted relative to 1.0 as the maximum, for convenience. Actually the maximum of the compensated curve is 122 times the maximum of the uncompensated. The compensated curve is seen to rise almost uniformly to 4,000 c. p. s. Above 4,000 c. p. s. it falls again because of the rapidly decreasing impedance of the compensating circuit above its resonant frequency.

In Figure 11 the performance of the hot wire, the amplifier, and the compensating circuit are summarized. The curve marked "amplifier distortion" is the performance of the uncompensated amplifier, as in Figure 10; the curve marked "uncompensated" represents the performance obtained by using the hot wire with the uncompensated amplifier, to the same scale; and the curve marked "compensated" is the performance resulting from the combination of hot wire and compensated amplifier also to the same scale. The "compensated" curve is seen to be within 2 per cent

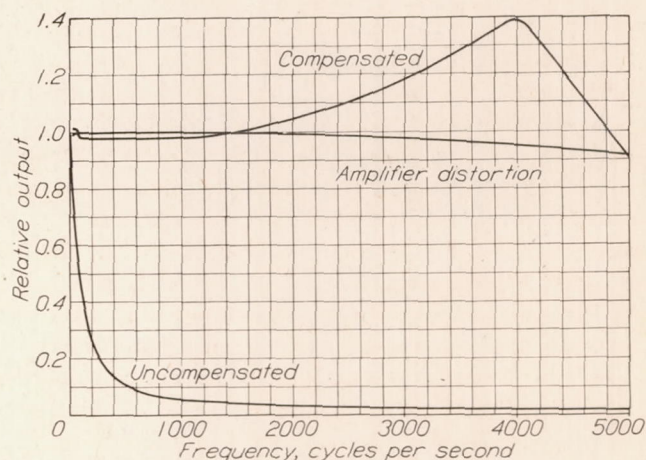

FIGURE 11.—Frequency characteristic of amplifier and hot wire

of the ideal, represented by the ordinate 1.0, from 25 to 2,000 c. p. s. This is the performance of the amplifier as now used. It is to be especially noted that the output of the amplifier does not fall below the ideal until 5,000 c. p. s. is reached, thus insuring that any high frequencies existing in the turbulent air flow will make their presence felt in the observations.

FINAL MEASURING INSTRUMENT

The fifth section of the measuring assembly, namely, the final measuring instrument, remains, in general, the 0 to 5 m. a. thermocouple milliammeter used in all previous work. Reference to Figure 8 will show that it is normally short-circuited by a key or switch. This has been found necessary because of the frequency with which disturbances large enough to burn out the meter occur. It is very essential to avoid making any adjustments in the amplifier or associated equipment, or even touching any portion of the input circuit, when the meter is not shortcircuited. Otherwise, a burned-out milliammeter is almost certain to result. As a

further precaution, a direct-current milliammeter is connected in series with the thermocouple instrument to indicate whether or not the balance of the direct-current voltage drop across the amplifier output resistor is correct. If this meter does not read zero the balance is imperfect and must be adjusted before removing the short-circuit from the thermocouple milli-

reduce the sensitivity because of the resistance introduced in series with the meter.

The thermocouple milliammeter has been supplemented for some purposes by a General Radio cathode-ray oscillograph. The oscillograph is found very useful for visual inspection of the wave form and has been used with a moving-film camera for making permanent

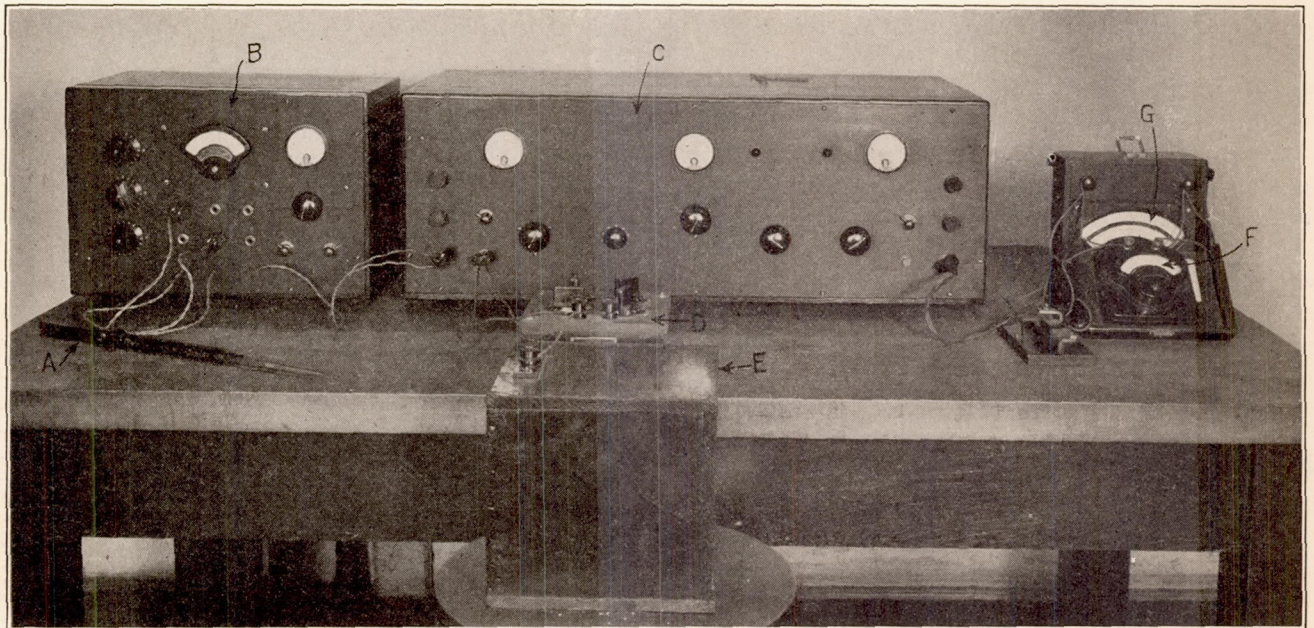

- A. Support for the hot wire.
- B. Controls, measuring instruments and switching circuits for power supply to the hot wire, and for measurement of mean air speed.
- C. Amplifier.
- D. Resistance R of compensating circuit.
- E. Inductance L of compensating circuit.
- F. Direct-current milliammeter.
- G. Thermocouple actuated alternating-current milliammeter.

FIGURE 12.—Turbulence-measuring apparatus (batteries not shown)

ammeter. The direct-current milliammeter is also a useful indicator of the magnitude of the slower fluctuations in the turbulence. If the reading of the direct-current milliammeter is fluctuating more than one or two milliamperes it is unsafe to put the thermocouple milliammeter in the circuit.

We have not been able to find suitable fuses to protect this meter, which do not at the same time greatly

records. It is also useful for checking the performance of the amplifier by comparing the shape of an amplified sinusoidal voltage wave with the original. The cathode-ray oscillograph may also be used as a visual check on the accuracy of the compensation according to the method of Ziegler. (Reference 9.)

Since the output of the main amplifier is insufficient to operate the cathode-ray tube from the low levels of

turbulence found in the free stream of the wind tunnel, an additional stage of amplification is employed. This consists of a single RCA247 pentode vacuum tube, resistance-capacity coupled to the main amplifier, and working into a load resistor of 7,000 ohms, with plate and screen-grid voltages of 250 and 200 volts, respectively. Under these conditions the voltage gain of the

visual observation the time axis is supplied by a revolving or rocking mirror, while for permanent records the moving-film camera is used. It has been found that a film speed of approximately one foot per second may be used under the usual conditions of spot brightness and film sensitivity. The film employed to date has been regular Eastman negative motion-picture

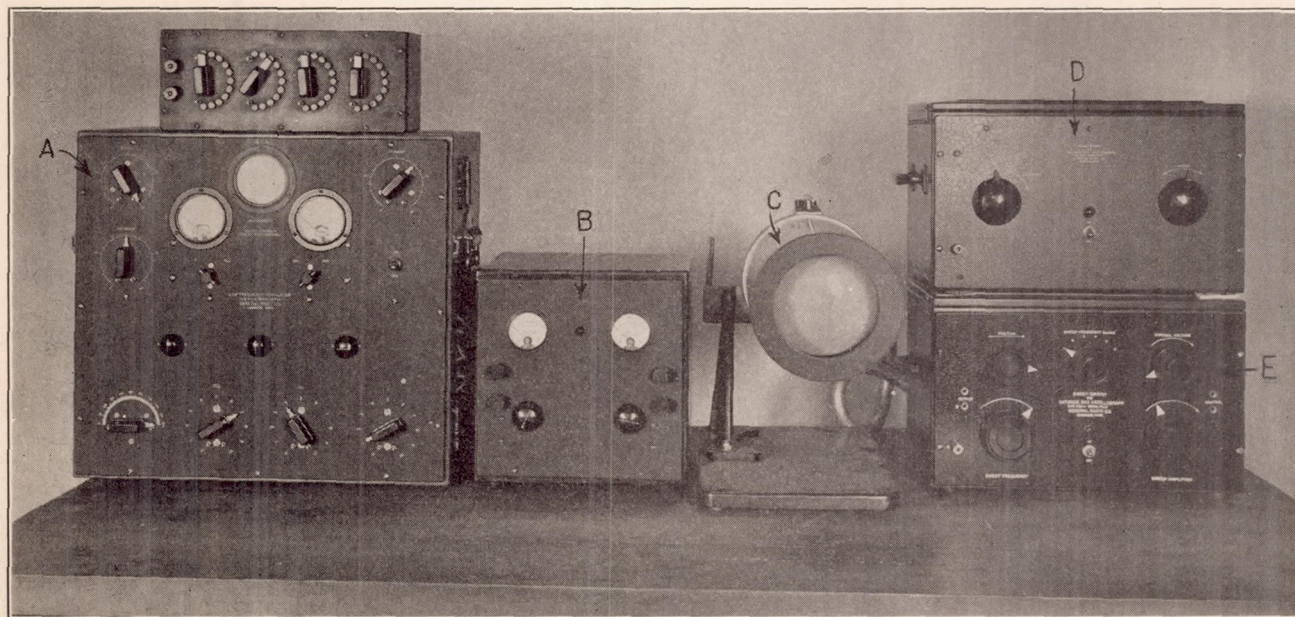

A. Audio-frequency oscillator for calibrating and studying the distortion of the amplifier.

B. Single-stage amplifier for use with cathode-ray oscillograph.

C. Cathode-ray oscillograph tube.

D. Power-supply unit for cathode-ray oscillograph.

E. Time-axis apparatus for cathode-ray oscillograph.

FIGURE 13.—Auxiliary equipment for use with turbulence-measuring apparatus

stage is about 11 and the permissible grid swing is about 22 volts; hence an output peak voltage swing of as much as 132 volts may be obtained. One pair of the two sets of deflecting plates of the cathode ray tube is connected across the output resistor of the pentode amplifier through a $1.0\mu f$ condenser and the cathode-ray beam thus deflected by the alternating voltage appearing across the output resistor. For

film. It is thought that the use of the newer and extremely sensitive panchromatic films might permit higher film speeds.

The wire mounting, amplifier, etc. (without batteries), are shown in Figure 12, and the audio-frequency oscillator, cathode-ray oscillograph tube, and auxiliary equipment in Figure 13.

33x10³
250
5000 = 18
100

REPORT No. 448

IMPROVED APPARATUS FOR THE MEASUREMENT OF FLUCTUATIONS OF AIR SPEED IN TURBULENT FLOW

PART IV

EXPERIMENTAL DETERMINATION OF THE FREQUENCY DISTRIBUTION OF THE SPEED FLUCTUATIONS

The question of the frequencies present in the speed fluctuations is one of great interest. Knowledge of the range of frequencies involved would be of help in the design of the compensating circuit, and might throw much needed light on the nature of turbulence.

In 1931 several attempts were made to determine the frequencies present in the fluctuations in the free stream of the Bureau of Standards 54-inch wind tunnel. In the first of these experiments an amplifier was used, which passed a narrow band of frequencies, the location of which in the audio-frequency spectrum could be controlled. It was thought that by means of this arrangement it might be possible to compare the amplifier outputs at various settings of the band circuit and obtain some information regarding the distribution of the energy of the fluctuations with frequency.

The amplifier used for this purpose was one of several stages of resistance-capacity coupled UY224 vacuum tubes preceded by one stage in which the load circuit consisted of a fixed inductance L , and a variable capacity C , in parallel, instead of the plain resistance load used in the following stages. This inductance-capacity parallel circuit resonates at a frequency

$$f_r = \frac{1}{2\pi \sqrt{LC}} \quad (17)$$

neglecting the small effect of the resistance R , of the coil having the inductance L . At the resonant frequency the circuit presents an impedance,

$$Z_r = \frac{L}{RC} \quad (18)$$

At frequencies much different from that of resonance the impedance is very low. Since the inductance-capacity circuit acts as the load circuit of the vacuum tube with which it is associated, the amplification obtained in that tube is given by equation (12) where Z_0 is the impedance of the inductance-capacity combination, and the effect of interelectrode capacities is neglected. The amplification is very low at all fre-

quencies except those at and near the resonant frequency f_r . By varying the capacity C , the resonant frequency may be shifted as desired, and by connecting the amplifier to the hot wire in the usual manner and taking output readings at several settings of the capacity C , some qualitative information regarding the frequency distribution in the speed fluctuation may be obtained. Quantitative data is not easily obtained by this method for two reasons. First, the amplification at resonance depends on the relation between L and C , as expressed by equation (18), and since C is variable the amplification will be different for each setting of C . The selectivity or sharpness of the resonant circuit may be defined as the fractional change in impedance for a given change in either C or L at resonance, which may in turn be shown to be equal to the ratio of the inductive reactance to the resistance of the inductance; that is, $\frac{2\pi f_r L}{R}$. Therefore, the selectivity, or width of the band of frequencies amplified, depends on the frequency of resonance.

The first difficulty, that of unequal amplification at each of the various capacity settings, may be more or less easily remedied by calibrating the amplifier at each of the various condenser settings and making appropriate corrections to the outputs obtained.

The second difficulty, that of unequal selectivity of the system, is not so easily corrected. The method of correction employed consisted of plotting the response of the amplifier against frequency for each of the condenser settings and measuring the area under the curves thus obtained, between certain limits of frequency. These areas were then used as the basis of a correction to be applied to the output readings.

The effectiveness of the highly selective amplifier was checked experimentally by introducing a pronounced and definite frequency into the turbulence by means of mounting the hot wire in the wake of a round rod placed in the wind tunnel with its axis perpendicular to the direction of the flow. It was found possible to detect the frequency of the eddies in the wake of the rod quite easily by properly tuning

the inductance-capacity circuit. Furthermore, the frequency measured corresponded closely with the frequency computed from the velocity of flow and diameter of rod according to the well-known relation

$$f = 0.18 \frac{V}{D}$$

When the hot wire was placed in the free stream of the wind tunnel no definitely predominant frequency or frequencies could be detected, but by comparing the corrected experimental results with theoretical results predicted on the basis of various arbitrary distributions of frequency it was concluded that the turbulence was mainly of low frequency and the energy was probably distributed in some such manner as 90 per cent between 25 and 500 c. p. s., and 10 per cent between 500 and 1,000 c. p. s. No conclusions could be drawn regarding frequencies much below 25 c. p. s., because the amplifier was inoperative in that frequency range.

The second attempt to determine the frequency distribution in the turbulence arose from the desire to eliminate the effect of the unequal selectivity, and the rather unsatisfactory correction for it. Use was made of an apparatus for sound analysis developed by Theodorsen. (Reference 10.)

Briefly, the operation of Theodorsen's apparatus is dependent on the fact that the energy loss in an ohmic resistance through which a complex current wave flows is equal to the sum of the energy losses due to the harmonic components of the complex wave, except in the case in which there are two components of the same frequency in phase with each other, in which instance the energy loss is increased by a certain amount. Practical use is made of this principle by causing the complex wave to flow in a hot wire through which an alternating current of sine wave form and controllable frequency also flows. When the controlled wave is adjusted to the same frequency as that of any component of the complex wave the energy dissipated in the hot wire in the form of heat is increased or decreased relative to the dissipation due to the sum of the component losses, depending on the phase relationship. The temperature of the hot wire rises or falls, resulting in a change in resistance, and therefore in the voltage drop, which may be amplified and recorded. The principal advantage of this system of frequency is its great and uniform selectivity. All components of the complex wave are detected with equal selectivity and their effects are proportional to their amplitudes.

The successful use of Theodorsen's apparatus depends on the existence in the complex wave form of components constant in frequency; otherwise it would be impossible to set the controlled wave to the same frequency as the component.

When an attempt was made to analyze the complex wave resulting from the amplified and compensated effect of the wind-tunnel turbulence on the hot-wire anemometer by means of the apparatus described above, entirely negative results were obtained. This we believe to be due to the absence from the turbulence of any components sufficiently constant in frequency to be detected by the very selective apparatus.

The third, and perhaps most definitely successful attack on the frequency distribution problem was made by the use of a cathode ray oscillograph. Using this instrument, with its auxiliary amplifier, on the output of the compensated amplifier, moving film records were made of the turbulence in the free stream of the wind tunnel. The speed of the moving film being known, it was possible to count the number of velocity fluctuations occurring in a given length of the record or, if advisable, to make a harmonic analysis.

Records were made using a hot wire of 2 mm length, in place of the usual 1 cm type, in the hope that the shorter wire might exhibit a better response to the high frequencies. There is some evidence that the physical dimensions of the higher frequency velocity fluctuations may be so small as to cause their effect to cancel out over the 1 cm length of the longer wire. Measurements made with long and short wires alternately indicated very little, if any difference, however, in the mean amplitude of the fluctuations.

The greatest number of maxima found in the moving-film records was in every instance between 300 and 400 per second, including those records made when using the 2 mm wire. Since, as shown by Figure 11, the performance of the amplifier and compensator is entirely adequate for the reproduction of frequencies up to 5,000 c. p. s., and the records show no trace of reversals of higher frequency than 300 or 400 per second, it seems quite permissible to conclude that reversals of greater frequency than 400 c. p. s. either do not exist in the turbulence or are so small in effect as to be unnoticeable, even under the favorable conditions existing in the apparatus. This conclusion is in agreement with the qualitative data as to frequency distribution derived from the experiments with the inductance-capacity tuned selective amplifier.

Since the fluctuations are not sinusoidal, the reproduction of frequencies much higher than the frequency of the reversals is necessary correctly to reproduce the wave form.

Unfortunately, because of the limited illumination available, and the necessity of using a rather high film speed in order to record any high frequencies that might exist in the turbulence, the records obtained were too faint for satisfactory half-tone reproduction, and therefore could not be included in this report. They were, however, quite satisfactory for their original purpose of supplying data regarding the wave form of the fluctuation.

ACKNOWLEDGMENT

We wish to acknowledge the assistance of Mr. S. S. West in the construction and operation of much of the apparatus and of Mr. B. H. Monish in the preparation of photographic records.

BUREAU OF STANDARDS,
WASHINGTON, D. C., *Sept., 1932.*

REFERENCES

1. Reynolds, Osborne: On the Dynamical Theory of Incompressible Viscous Fluids and the Determination of the Criterion. *Phil. Trans. Roy. Soc.*, Vol. 186, Part I, 1895.
2. Lorentz, H. A.: *Abhandlungen über Theoretische Physik*, Leipzig, p. 43, 1907.
3. Burgers, J. M.: *Versl. Kon. Akad. v. Wetensch., Amsterdam*, Vol. 26, p. 582, 1923.
4. Huguenard, E., Magnan, A., and Planiol, A.: A Method for the Instantaneous Determination of the Velocity and Direction of the Wind. *T. M. No. 264, N. A. C. A.*, 1924.
5. Dryden, H. L., and Kuethe, A. M.: The Measurement of Fluctuations of Air Speed by the Hot-Wire Anemometer, *T. R. No. 320, N. A. C. A.*, 1929.
6. Dryden, H. L., and Kuethe, A. M.: Effect of Turbulence in Wind Tunnel Measurements. *T. R. No. 342, N. A. C. A.*, 1930.
7. Ziegler, M.: The Application of the Hot-Wire Anemometer for the Investigation of the Turbulence of an Airstream. *Versl. d. Kon. Akad. v. Wetensch., Amsterdam*, vol. 33, p. 723, 1930.
8. Doetsch, H., and v. Mathes, P.: *Über Schwankungsmessungen im Aachener Windkanal.* *Abh. Aerodyn. Inst. Aachen*, No. 10, p. 22, 1931.
9. Ziegler, M.: A Complete Arrangement for the Investigation, the Measurement and the Recording of Rapid Airspeed Fluctuations with Very Thin and Short Hot Wires. *Versl. Kon. v. Wetensch., Amsterdam*, Vol. 34, p. 663, 1931.
10. Theodorsen, Theodore: A New Principle of Sound Frequency Analysis. *T. R. No. 395, N. A. C. A.*, 1931.

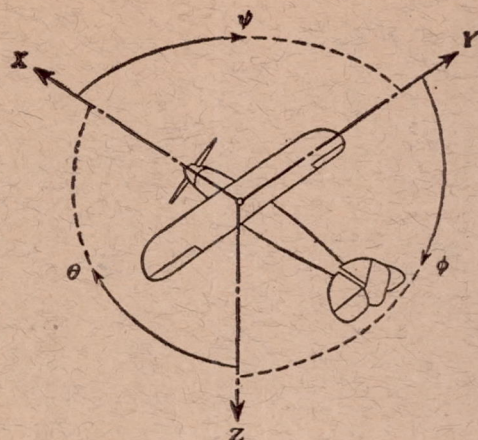

Positive directions of axes and angles (forces and moments) are shown by arrows

Axis		Force (parallel to axis) symbol	Moment about axis			Angle		Velocities	
Designation	Sym- bol		Designation	Sym- bol	Positive direction	Designa- tion	Sym- bol	Linear (compo- nent along axis)	Angular
Longitudinal	X	X	rolling	L	Y → Z	roll	φ	u	p
Lateral	Y	Y	pitching	M	Z → X	pitch	θ	v	q
Normal	Z	Z	yawing	N	X → Y	yaw	ψ	w	r

Absolute coefficients of moment

$$C_l = \frac{L}{qbS}$$

$$C_m = \frac{M}{qcS}$$

$$C_n = \frac{N}{qbS}$$

Angle of set of control surface (relative to neutral position), δ . (Indicate surface by proper subscript.)

4. PROPELLER SYMBOLS

D , Diameter.

p , Geometric pitch.

p/D , Pitch ratio.

V' , Inflow velocity.

V_s , Slipstream velocity.

T , Thrust, absolute coefficient $C_T = \frac{T}{\rho n^2 D^4}$

Q , Torque, absolute coefficient $C_Q = \frac{Q}{\rho n^2 D^5}$

P , Power, absolute coefficient $C_P = \frac{P}{\rho n^3 D^5}$.

C_s , Speed power coefficient = $\sqrt[5]{\frac{\rho V^5}{P n^2}}$.

η , Efficiency.

n , Revolutions per second, r. p. s.

Φ , Effective helix angle = $\tan^{-1} \left(\frac{V}{2\pi r n} \right)$

5. NUMERICAL RELATIONS

1 hp = 76.04 kg/m/s = 550 lb./ft./sec.

1 kg/m/s = 0.01315 hp

1 mi./hr. = 0.44704 m/s

1 m/s = 2.23693 mi./hr.

1 lb. = 0.4535924277 kg.

1 kg = 2.2046224 lb.

1 mi. = 1609.35 m = 5280 ft.

1 m = 3.2808333 ft.