

FILE COPY  
NO. I-W

CASE FILE  
COPY

# NATIONAL ADVISORY COMMITTEE FOR AERONAUTICS

REPORT No. 606

## ELECTRICAL THERMOMETERS FOR AIRCRAFT

By JOHN B. PETERSON and S. H. J. WOMACK



FILE COPY  
To be returned to  
the files of the National  
Advisory Committee  
for Aeronautics  
Washington, D. C.

1937

## AERONAUTIC SYMBOLS

### 1. FUNDAMENTAL AND DERIVED UNITS

	Symbol	Metric		English	
		Unit	Abbreviation	Unit	Abbreviation
Length.....	$l$	meter.....	m	foot (or mile).....	ft. (or mi.)
Time.....	$t$	second.....	s	second (or hour).....	sec. (or hr.)
Force.....	$F$	weight of 1 kilogram.....	kg	weight of 1 pound.....	lb.
Power.....	$P$	horsepower (metric).....		horsepower.....	hp.
Speed.....	$V$	kilometers per hour.....	k.p.h.	miles per hour.....	m.p.h.
		meters per second.....	m.p.s.	feet per second.....	f.p.s.

### 2. GENERAL SYMBOLS

<p><math>W</math>, Weight = <math>mg</math></p> <p><math>g</math>, Standard acceleration of gravity = 9.80665 m/s<sup>2</sup> or 32.1740 ft./sec.<sup>2</sup></p> <p><math>m</math>, Mass = <math>\frac{W}{g}</math></p> <p><math>I</math>, Moment of inertia = <math>mk^2</math>. (Indicate axis of radius of gyration <math>k</math> by proper subscript.)</p> <p><math>\mu</math>, Coefficient of viscosity</p>	<p><math>\nu</math>, Kinematic viscosity</p> <p><math>\rho</math>, Density (mass per unit volume) Standard density of dry air, 0.12497 kg-m<sup>-4</sup>-s<sup>2</sup> at 15° C. and 760 mm; or 0.002378 lb.-ft.<sup>-4</sup> sec.<sup>2</sup></p> <p>Specific weight of "standard" air, 1.2255 kg/m<sup>3</sup> or 0.07651 lb./cu. ft.</p>
--	---

### 3. AERODYNAMIC SYMBOLS

<p><math>S</math>, Area</p> <p><math>S_w</math>, Area of wing</p> <p><math>G</math>, Gap</p> <p><math>b</math>, Span</p> <p><math>c</math>, Chord</p> <p><math>\frac{b^2}{S}</math>, Aspect ratio</p> <p><math>V</math>, True air speed</p> <p><math>q</math>, Dynamic pressure = <math>\frac{1}{2}\rho V^2</math></p> <p><math>L</math>, Lift, absolute coefficient <math>C_L = \frac{L}{qS}</math></p> <p><math>D</math>, Drag, absolute coefficient <math>C_D = \frac{D}{qS}</math></p> <p><math>D_0</math>, Profile drag, absolute coefficient <math>C_{D_0} = \frac{D_0}{qS}</math></p> <p><math>D_i</math>, Induced drag, absolute coefficient <math>C_{D_i} = \frac{D_i}{qS}</math></p> <p><math>D_p</math>, Parasite drag, absolute coefficient <math>C_{D_p} = \frac{D_p}{qS}</math></p> <p><math>C</math>, Cross-wind force, absolute coefficient <math>C_C = \frac{C}{qS}</math></p> <p><math>R</math>, Resultant force</p>	<p><math>i_w</math>, Angle of setting of wings (relative to thrust line)</p> <p><math>i_s</math>, Angle of stabilizer setting (relative to thrust line)</p> <p><math>Q</math>, Resultant moment</p> <p><math>\Omega</math>, Resultant angular velocity</p> <p><math>\rho \frac{Vl}{\mu}</math>, Reynolds Number, where <math>l</math> is a linear dimension (e.g., for a model airfoil 3 in. chord, 100 m.p.h. normal pressure at 15° C., the corresponding number is 234,000; or for a model of 10 cm chord, 40 m.p.s., the corresponding number is 274,000)</p> <p><math>C_p</math>, Center-of-pressure coefficient (ratio of distance of c.p. from leading edge to chord length)</p> <p><math>\alpha</math>, Angle of attack</p> <p><math>\epsilon</math>, Angle of downwash</p> <p><math>\alpha_0</math>, Angle of attack, infinite aspect ratio</p> <p><math>\alpha_i</math>, Angle of attack, induced</p> <p><math>\alpha_a</math>, Angle of attack, absolute (measured from zero-lift position)</p> <p><math>\gamma</math>, Flight-path angle</p>
--	--

---

---

**REPORT No. 606**

---

**ELECTRICAL THERMOMETERS FOR AIRCRAFT**

By JOHN B. PETERSON and S. H. J. WOMACK  
National Bureau of Standards

---

---

i

## NATIONAL ADVISORY COMMITTEE FOR AERONAUTICS

HEADQUARTERS, NAVY BUILDING, WASHINGTON, D. C.

LABORATORIES, LANGLEY FIELD, VA.

Created by act of Congress approved March 3, 1915, for the supervision and direction of the scientific study of the problems of flight (U. S. Code, Title 50, Sec. 151). Its membership was increased to 15 by act approved March 2, 1929. The members are appointed by the President, and serve as such without compensation.

JOSEPH S. AMES, Ph. D., <i>Chairman</i> , Baltimore, Md.	SYDNEY M. KRAUS, Captain, United States Navy, Bureau of Aeronautics, Navy Department.
DAVID W. TAYLOR, D. Eng., <i>Vice Chairman</i> , Washington, D. C.	CHARLES A. LINDBERGH, LL. D., New York City.
WILLIS RAY GREGG, Sc. D., <i>Chairman, Executive Committee</i> , Chief, United States Weather Bureau.	WILLIAM P. MACCRACKEN, J. D., Washington, D. C.
CHARLES G. ABBOT, Sc. D., Secretary, Smithsonian Institution.	AUGUSTINE W. ROBINS, Brigadier General, United States Army, Chief Matériel Division, Air Corps, Wright Field, Day- ton, Ohio.
LYMAN J. BRIGGS, Ph. D., Director, National Bureau of Standards.	EDWARD P. WARNER, M. S., Greenwich, Conn.
ARTHUR B. COOK, Rear Admiral, United States Navy, Chief, Bureau of Aeronautics, Navy Department.	OSCAR WESTOVER, Major General, United States Army, Chief of Air Corps, War Department.
FRED D. FAGG, JR., J. D., Director of Air Commerce, Department of Commerce.	ORVILLE WRIGHT, Sc. D., Dayton, Ohio.
HARRY F. GUGGENHEIM, M. A., Port Washington, Long Island, N. Y.	

GEORGE W. LEWIS, *Director of Aeronautical Research*

JOHN F. VICTORY, *Secretary*

HENRY J. E. REID, *Engineer in Charge, Langley Memorial Aeronautical Laboratory, Langley Field, Va.*

JOHN J. IDE, *Technical Assistant in Europe, Paris, France*

### TECHNICAL COMMITTEES

AERODYNAMICS  
POWER PLANTS FOR AIRCRAFT  
AIRCRAFT MATERIALS

AIRCRAFT STRUCTURES  
AIRCRAFT ACCIDENTS  
INVENTIONS AND DESIGNS

*Coordination of Research Needs of Military and Civil Aviation*

*Preparation of Research Programs*

*Allocation of Problems*

*Prevention of Duplication*

*Consideration of Inventions*

LANGLEY MEMORIAL AERONAUTICAL LABORATORY

LANGLEY FIELD, VA.

Unified conduct, for all agencies, of scientific research on the fundamental problems of flight.

OFFICE OF AERONAUTICAL INTELLIGENCE

WASHINGTON, D. C.

Collection, classification, compilation, and dissemination of scientific and technical information on aeronautics.

## REPORT No. 606

### ELECTRICAL THERMOMETERS FOR AIRCRAFT

By JOHN B. PETERSON and S. H. J. WOMACK

#### SUMMARY

*Electrical thermometers commonly used on aircraft are the thermoelectric type for measuring engine-cylinder temperatures, the resistance type for measuring air temperatures, and the superheat meters of the thermoelectric and resistance types for use on airships. These instruments are described and their advantages and disadvantages enumerated. Methods of testing these instruments and the performance to be expected from each are discussed. The field testing of engine cylinder thermometers is treated in detail.*

#### INTRODUCTION

On aircraft a knowledge of the temperature of the engine is valuable (1) as an indication of trouble and (2) as an aid in normal operation. An indication of abnormal temperature of the engine cylinder, lubricating oil, or cooling liquid may forewarn of impending failure. Where temperature controls are provided, the temperature of the engine may be maintained at values for which the operation of the engine is most efficient.

A knowledge of the air temperature is essential in flight testing and as a warning of the possibility of ice formation. One of the most important quantities measured in airplane and balloon flights made to obtain meteorological data is the air temperature.

On airships both the air temperature and the difference between the air and lifting-gas temperatures are commonly measured. These data are vital factors in airship navigation.

When measuring temperatures on aircraft, it is obvious that the indicator must in most cases be at a distance from the point of measurement. Electrical thermometers, being inherently suitable for distant indication, are widely used. As an exception, vapor-pressure thermometers are commonly used to measure the temperature of the cooling water or lubricating oil of aircraft engines (reference 1).

Both thermoelectric and resistance types of electrical thermometers are used on aircraft. The choice between the two types of instruments lies principally in the accuracy required. An accuracy of 10° C. is suf-

ficient in the measurement of engine temperatures whereas an accuracy of 1° C. is desired in the measurement of air temperatures. The thermoelectric type is used, to the exclusion of other types, for the indication of the temperature of air-cooled engine cylinders. This type is particularly suitable for this use because (1) the required accuracy can be obtained by using a single thermocouple with a relatively rugged moving coil instrument, and (2) the thermocouple element is more easily connected thermally to the engine cylinder than any other type. The resistance thermometer is used when a more accurate determination of temperature over a shorter range is desired, as in the measurement of air temperatures.

Superheat meters for airships may be either of the thermoelectric or resistance type. A number of factors must be considered in choosing between the two types. These are discussed in the section on these instruments.

The instruments described in this report include (1) the thermoelectric-type engine-cylinder thermometer, (2) a resistance-type thermometer for measurement of air temperatures, (3) the thermoelectric and the resistance types of superheat meters, and (4) a tester for testing engine-cylinder thermometers. All of these instruments with the exception of the first have been developed at the National Bureau of Standards for use of the Bureau of Aeronautics, Navy Department. The National Advisory Committee for Aeronautics furnished the financial assistance necessary for the preparation of this report.

Where testing methods are described in detail in this report, the methods are those followed at the National Bureau of Standards in testing instruments purchased by the Bureau of Aeronautics, Navy Department.

#### ENGINE-CYLINDER THERMOMETERS

**The thermoelectric circuit.**—A diagram of the electrical circuit of an engine-cylinder thermometer with a copper-constantan thermocouple is shown in figure 1. Figure 2 is a diagram of the electrical circuit of a thermometer using several iron-constantan thermocouples with a selector switch. The comparative advantages

and disadvantages of different thermoelectric materials will be discussed later.

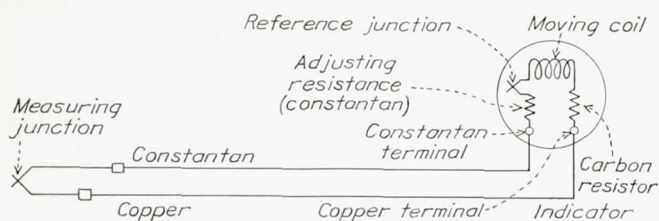

FIGURE 1.—Diagram of the electrical circuit of an engine-cylinder thermometer with a copper-constantan thermocouple.

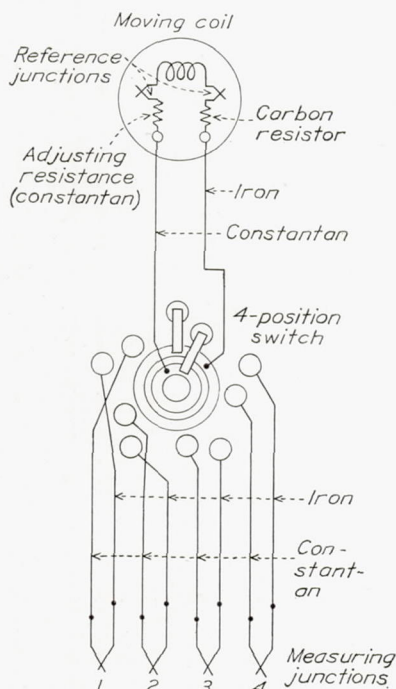

FIGURE 2.—Diagram of the electrical circuit of an engine-cylinder thermometer with a four-position selector switch and iron-constantan thermocouples.

The final design of the circuit is a compromise between many conflicting requirements. The energy available to operate the indicator is limited to the output of the single thermocouple. It follows that a sensitive indicator should be used; yet for operation on an airplane the indicator should have a high torque. The use of a stronger permanent magnet offers advantages in this respect but the difficulties of shielding the instrument so that it will not affect the magnetic compass are increased. The increased weight of a larger magnet is also objectionable.

**Thermocouples and leads.**—The choice of the most suitable combination of thermoelectric materials depends on several factors:

1. The thermoelectric power ( $dE/dT$ ) should be high.
2. The mechanical strength after repeated heating and cooling should be good.
3. There should be high resistance to corrosion.
4. The thermal conductivity of the material should be low, so as not to conduct heat away from the part, the temperature of which is being measured.

5. The electrical resistance should be low.
6. The temperature coefficient of electrical resistance should be low.
7. A uniform supply of the material should be obtainable.

A comparison of these seven characteristics for several combinations of thermoelectric materials is given in table I. The first three combinations, are at present used in measuring aircraft engine cylinder temperatures, and the fourth, chromel P-constantan is proposed for this service.

It should be pointed out that the change in resistance per °C., given in table I applies only to the resistance of the leads, which is usually about 0.1 of the total resistance of the circuit.

TABLE I.—PROPERTIES OF THERMOELECTRIC MATERIALS

	$dE/dT$ <sup>1</sup>	Electrical resistance <sup>2</sup>	Change in resistance per degree centigrade <sup>3</sup>	Relative thermal conductivity <sup>4</sup>	Mechanical strength	Resistance to corrosion	Uniformity of supply
Copper.....	49.5	.074	.012	100	Poor...	Fair....	Excellent.
Constantan..					Good...	Good...	Fair.
Chromel P.....	40.7	.147	.096	5	do....	do....	do.
Alumel.....					do....	do....	Good.
Iron.....	55.2	.087	.094	18	do....	Poor....	Fair.
Constantan..					do....	Good....	do.
Chromel P.....	70.1	.176	.024	5	do....	do....	Good.
Constantan..					do....	do....	Fair.

<sup>1</sup> Average microvolts per degree centigrade in the range 0 to 300° C.  
<sup>2</sup> Ohms per foot of no. 14 duplex lead, at 20° C., based on the following resistances of the materials in ohms per foot of no. 14 wire: Copper, 0.002525; constantan, 0.0719; chromel P, 0.104; alumel, 0.0433; iron, 0.0149.  
<sup>3</sup> Average change in resistance per degree centigrade for the range 20 to -30° C. expressed as a percentage of the resistance at 20° C.  
<sup>4</sup> Thermal conductivity of copper=100.

TABLE II.—AVERAGE TEMPERATURE-E. M. F. CHARACTERISTICS OF THERMOCOUPLES

[Reference 3 is the source of data for chromel-alumel and copper constantan in the range -20 to 50° C. The data for higher temperatures for chromel-alumel were obtained from reference 3, and for copper constantan from reference 4. The iron-constantan and chromel P-constantan curves are from unpublished data on file in the Pyrometry Section of the National Bureau of Standards.]

Temperature		Electromotive force, millivolts			
° C.	° F.	Copper-constantan	Chromel P-alumel	Iron-constantan	Chromel P-constantan
-20	-4	-0.75	-0.77	-1.03	-1.14
-15	5	-.57	-.58	-.77	-.86
-10	14	-.38	-.39	-.52	-.58
-5	23	-.19	-.20	-.26	-.29
0	32	0	0	0	0
5	41	.19	.20	.26	.29
10	50	.39	.40	.52	.59
15	59	.59	.60	.78	.89
20	68	.79	.80	1.05	1.19
25	77	.99	1.00	1.31	1.49
30	86	1.19	1.20	1.58	1.79
35	95	1.40	1.40	1.85	2.10
40	104	1.61	1.61	2.12	2.41
45	113	1.82	1.81	2.38	2.72
50	122	2.03	2.02	2.66	3.04
100	212	4.28	4.10	5.40	6.32
150	302	6.70	6.13	8.19	9.79
200	392	9.28	8.13	10.99	13.42
250	482	12.01	10.15	13.79	17.18
300	572	14.86	12.21	16.56	21.03
350	662	17.82	14.29	19.32	24.96
400	752	-----	16.39	22.07	28.94
450	842	-----	18.50	24.82	32.96
500	932	-----	20.64	27.58	37.00
550	1,022	-----	22.77	30.39	41.05

Average temperature—e. m. f. relations for thermocouples of four combinations of materials are given in table II. The data for the lower temperatures are given at short intervals for convenience in applying corrections for the reference junction temperature or in calculations dealing with the range of compensators.

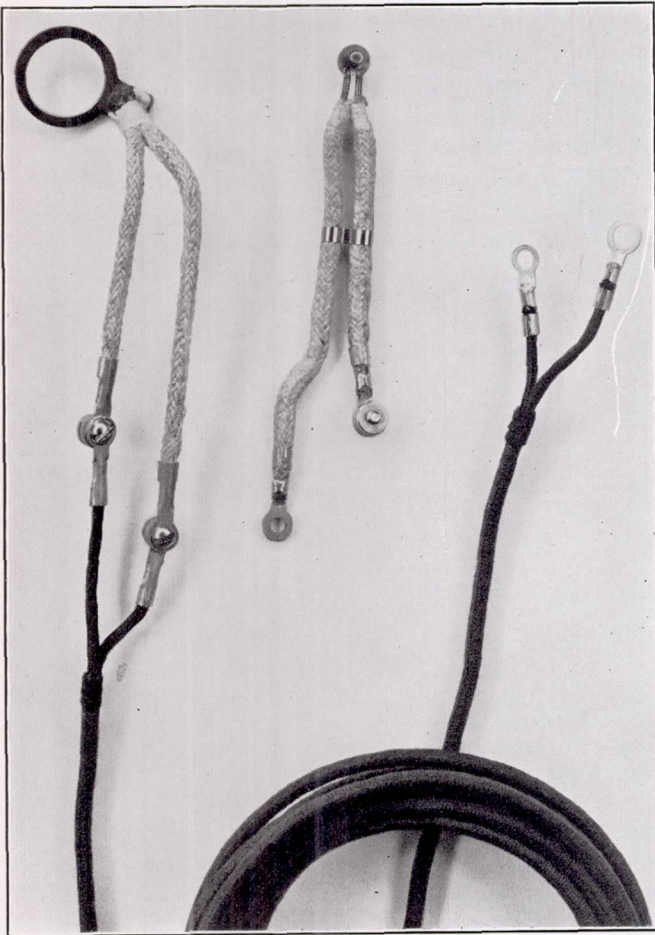

FIGURE 3.—Thermocouples of the gasket and rivet types and a pair of leads.

A photograph of two types of thermocouple is shown in figure 3. This particular equipment was constructed according to specifications of the Bureau of Aeronautics, Navy Department. The gasket-type thermocouple is mounted in place of the regular spark-plug gasket. The rivet-type thermocouple is inserted in a drilled hole,  $\frac{1}{8}$  inch in diameter and in depth, and a steel pin concentric with the rivet is driven down to expand the copper to hold the rivet securely in place. The thermocouple wires are welded to the gasket or rivet head.

The United States Army has standardized on 2-ohm iron-constantan thermocouples and the Navy, on 2-ohm copper-constantan thermocouples; engine manufacturers install 3-ohm iron-constantan thermocouples in commercial airplanes. These resistance values include both the resistances of the leads and thermocouples.

Thermocouple leads are made in lengths to fit any installation requirement. In order to make leads of different lengths interchangeable, the cross-sectional

area of the stranded wire is varied directly as the length so that all leads will have the same resistance. The leads are composed of two insulated conductors, of the same materials as the thermocouple, laid parallel, covered over-all with braid and saturated with flame- and moisture-resistant lacquer.

**Selector switches.**—When the temperatures of two or more points are to be measured with the same indicator, a selector switch of the required number of positions, a switch lead, and additional thermocouples are required. The switch lead and switch contact resist-

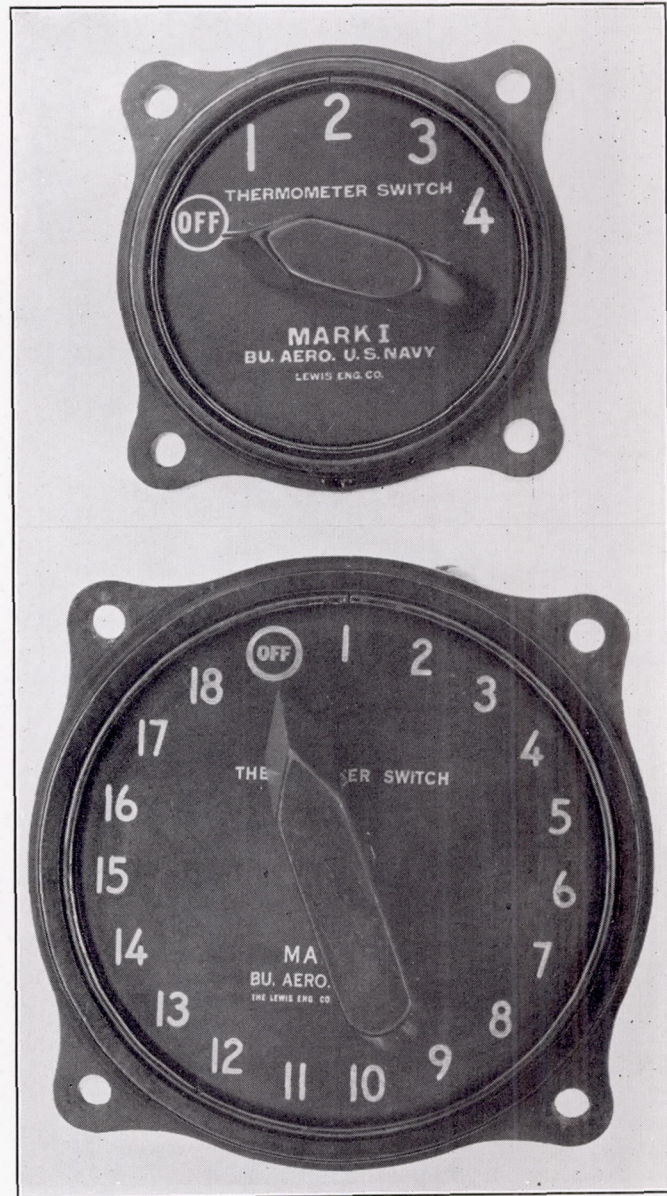

FIGURE 4.—Rotary selector switches for connecting an indicator to any one of a number of thermocouples.

ances are made low so as not appreciably to affect the indicated temperature. (See fig. 2 for a diagram of a 4-position and fig. 4 for a photograph of a 4-position and an 18-position rotary selector switch.) It is necessary that these switches be of the 2-pole type to avoid

stray voltages that might cause erroneous indications if one side of all the thermocouples remained permanently connected to the indicator.

**The electrical indicator.**—A face view of two electrical indicators is shown in figure 5. Both instruments are inclosed in Army-Navy standard cases of  $2\frac{3}{4}$  inch dial

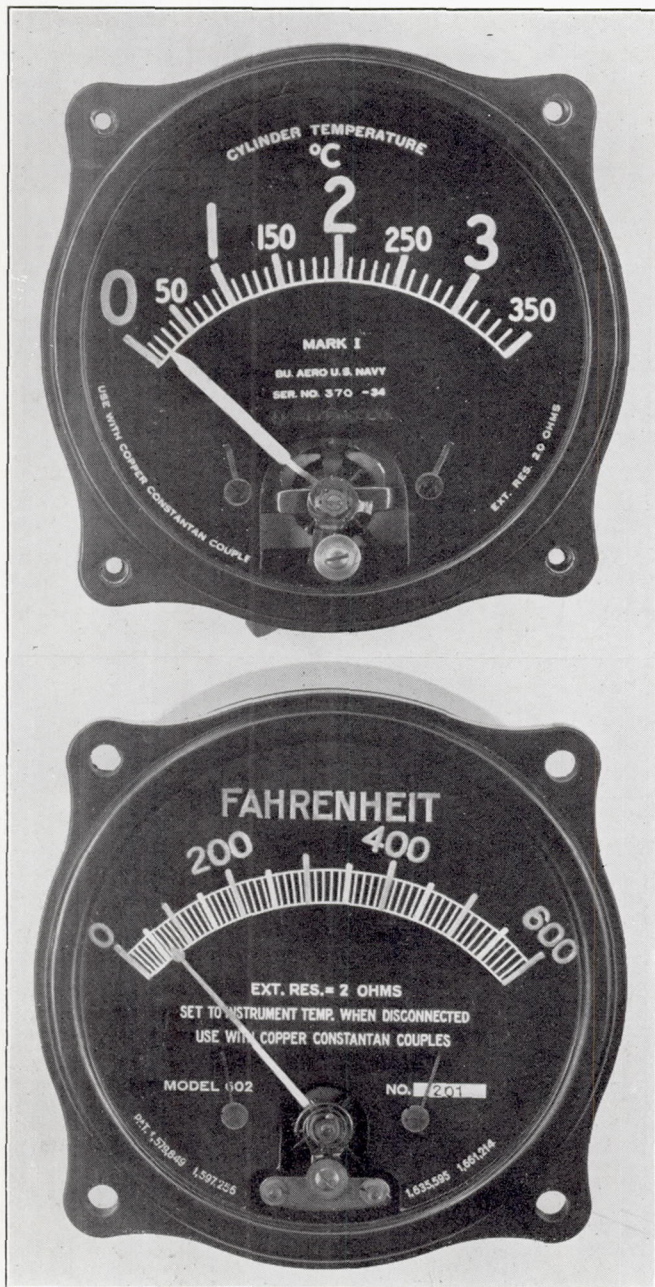

FIGURE 5.—Two engine-cylinder thermometer indicators.

diameter. Attached to the rear of the cases are terminals for connecting the thermocouple leads.

Because of the excessive vibration sometimes encountered on airplane instrument panels, the pivots which carry the moving coil of these indicators have been made blunter than those ordinarily used in electrical instruments. On airplanes there is always enough

vibration to overcome the slight friction caused by the blunt pivots. These blunt pivots are known as "air-plane pivots."

The electrical indicator must be magnetically shielded to reduce the effect of the permanent magnet on a magnetic compass. A soft-iron cup covers the sides and rear of the instrument and the front is shielded by a soft-iron dial. The shielding adds undesirable weight to an instrument already quite heavy because of the permanent magnet. The weights of indicators range from 1 to  $1\frac{3}{4}$  pounds.

**Reference-junction compensation.**—Compensation for the temperature of the reference junction is accomplished by a small bimetallic spiral, which controls the position of the outside end of one of the hairsprings. This construction is shown in figure 6. The proper

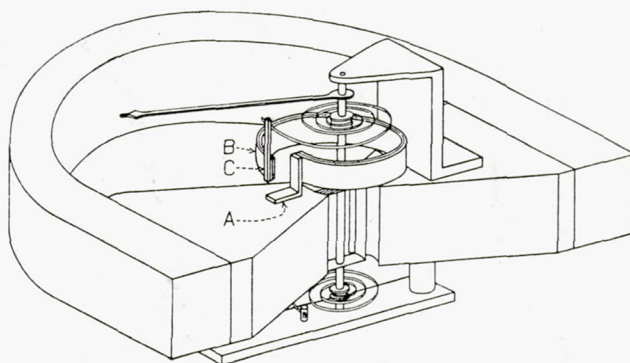

FIGURE 6.—Electrical indicator showing the Bristol reference junction compensator. B is the bimetallic spiral one end of which is fastened to the pole piece at A and the other to the hairspring at C.

action of the compensator is to cause the indicator, when there is no current in the moving coil, to indicate the ambient temperature. The bimetallic compensator and the reference junction should be placed closely together so that their temperatures will be the same. This requirement necessitates that the indicator terminal posts be constructed of the thermoelectric materials, so that there will be no intermediate junctions outside the instrument case. Furthermore, the rates of heating and cooling of the bimetallic compensator and reference junction should correspond, so that their temperatures will be the same for rapidly changing ambient temperatures.

It has become the general practice to connect a carbon resistor of negative temperature coefficient in series with the moving coil of the indicator, to compensate for the positive temperature coefficient of resistance of the copper in the moving coil.

**Tests and performance of indicators.**—The errors in indication of thermoelectric thermometers may be directly determined by immersing the measuring junction in a liquid bath and comparing the readings at a number of points with those of a calibrated thermometer. In practice, however, a more convenient method of determining the errors of engine cylinder thermome-



ters in use by the Bureau of Aeronautics is to test the indicator, leads, and thermocouple separately.

The Bureau of Aeronautics does not specify the resistance of the indicator, except that it shall be not less than 12 ohms at a temperature of 20° C. Since it is specified that the indication shall be correct when connected to a 2-ohm copper-constantan thermocouple, an exact specification of the resistance would be superfluous and would unnecessarily increase the cost of the instrument.

The scale errors of a millivoltmeter type indicator at room temperature are conveniently determined in the laboratory by connecting the indicator to a standard thermocouple (standard as regards temperature—e. m. f. relation and resistance) and then introducing into the circuit a voltage corresponding to that developed by the measuring junction at a given temperature. This junction is kept at a constant known temperature by placing it in an ice bath. The reading of the instrument

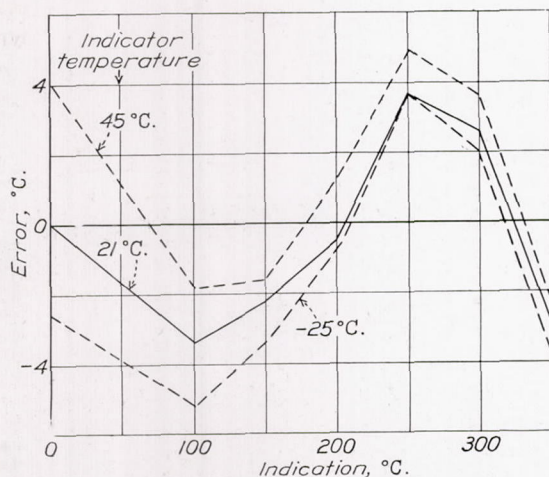

FIGURE 7.—Engine-cylinder thermometer errors for different indicator temperatures. The curves show the average of the errors of five indicators.

minus the temperature corresponding to the applied voltage gives the scale error.

Tests similar to the test described are made with the indicator at temperatures of  $-25$  and  $45^{\circ}$  C. to test the operation of the reference junction compensator and to determine the over-all effect of temperature on the scale error.

The average scale errors of five instruments at three temperatures have been plotted in figure 7. These instruments were equipped with bimetallic compensators and series carbon resistors of negative temperature coefficient. Besides affecting the reference junction and its compensator, a change in indicator temperature also affects the stiffness of the hair springs, the strength of the permanent magnet and the resistance of the moving coil. The data in figure 7 show that for these instruments the bimetallic spiral overcompensates for the temperature of the reference junction, while the carbon resistor undercompensates for the change in resistance of the copper coil. The combination is

adjusted so that the temperature error for the most important part of the scale, 200 to  $350^{\circ}$  C., is very small.

Figure 8 shows the results of a test to determine the change in reading of an indicator produced by a rapidly changing ambient temperature. The indicator is mounted in a chamber, the temperature of which is uniform and controllable, and connected to a thermocouple immersed in a liquid bath at room temperature. The pointer of the indicator is set to indicate the temperature of the bath. The temperature of the chamber in which the indicator is mounted is reduced from room temperature to approximately  $-25^{\circ}$  C. at a rate of approximately  $5^{\circ}$  C. per minute. The indicator should continue to indicate the constant temperature of the measuring junction in the liquid bath. Assuming that the bimetallic compensator has been properly adjusted and that the resistance of the carbon resistor has been properly selected so that the indication finally reaches the bath temperature, the deviation of the

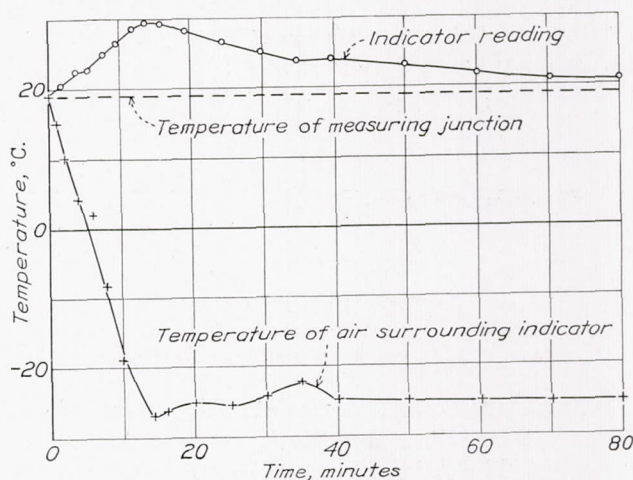

FIGURE 8.—The results of a temperature lag test on an indicator equipped with a bimetallic reference junction compensator.

indication from the bath temperature, as the temperature of the instrument is changed, is due to one or more of the following causes: (1) Improper placing of the reference junction with reference to the compensator; (2) uneven rates of heating and cooling of reference junction and compensator; (3) uneven rates of heating and cooling of the carbon resistor and copper coil; and (4) differences in temperature between the two ends of the carbon resistor.

The effect of vibration on the performance of the indicator is determined by subjecting the indicator to a vibration such that each point on the instrument case describes, in a plane inclined  $45^{\circ}$  to the horizontal, a circle of  $\frac{1}{32}$ -inch diameter. During this test the indicator is in the normal, face-vertical position. A description of the vibration machine on which this test is performed is given in reference 1. A voltage of specified value, which is normally sufficient to keep the pointer at approximately half of full-scale deflection, is introduced into the indicator circuit. The total

resistance in the indicator circuit is made equal to that existing in service, so as to obtain the same damping. The frequency of vibration is changed from 1,000 to 2,500 cycles per minute by steps, at each of which the average position of the pointer and the amplitude of oscillation is observed. The results of such a test are plotted in figure 9.

The cumulative effect of continuous vibration on the indicator is determined by subjecting it for periods up to 50 hours to vibrations at 1,800 vibrations per minute, maintaining the supply voltage as previously explained. Scale-error tests are made before and after vibrating, to determine the effect of vibration.

The effect of the indicator on the reading of a standard-type aircraft compass is determined by placing the indicator in various positions about the compass. The horizontal intensity of the magnetic field about the compass should be equal to 0.18 gauss for this test. The indicator shielding is considered satisfactory when, at a distance of 8 inches between the center of the indicator and the center of the compass, the change in compass reading is not more than  $4^\circ$ .

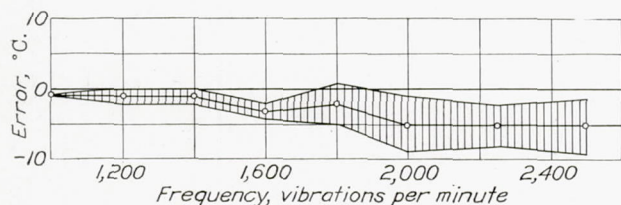

FIGURE 9.—Error in average position and amplitude of oscillation of pointer of typical engine cylinder thermometer when subjected to vibration.

**Testing thermocouple material.**—Thermocouple materials are tested at certain fixed points on the temperature scale. The melting point of ice ( $0^\circ\text{C}.$ ), the normal boiling point of water ( $100^\circ\text{C}.$ ), the freezing point of tin ( $231.9^\circ\text{C}.$ ), and the freezing point of lead ( $327.3^\circ\text{C}.$ ) are convenient points in the range of engine-cylinder thermometers. The methods used are described in detail by Roeser and Wensel in reference 2.

Some difficulties are experienced in testing short thermocouples, such as those illustrated in figure 3. If the longer wires necessary to connect the thermocouple to the potentiometer have not exactly the same thermoelectric properties as the wire of which the thermocouple is constructed, intermediate junctions are formed, the temperatures of which may be much higher than room temperature, owing to heat conduction along the short length of the thermocouple. Approximate corrections may be made for the temperatures of the intermediate junctions if these temperatures are measured by auxiliary thermocouples soldered onto the intermediate junctions. An easier and more accurate method, however, is to test sample thermocouples made of longer lengths of wire, from each batch of wire purchased.

The thermoelectric characteristics of the leads is found by joining the pair at one end to form a measur-

ing junction. The e. m. f.'s developed for measuring junction temperature elevations of  $50$  and  $100^\circ\text{C}.$  are measured directly on a potentiometer.

The Navy Department, Bureau of Aeronautics, specifications allow a deviation of approximately  $\pm 1$  percent from the e. m. f. of the standard temperature-e. m. f. relation for copper-constantan thermocouples and  $\pm 2$  percent for the leads. For interchangeability the resistances of thermocouples and leads should be uniform.

**Engine-cylinder thermometer tester.**—An instrument used in the field for testing copper-constantan thermoelectric type engine cylinder thermometers is shown in figure 10. Figure 11 is a diagram of the electrical con-



FIGURE 10.—Tester for copper-constantan thermoelectric thermometers.

nections of the tester. This tester was built according to the design and specifications of the Bureau of Aeronautics. The tester is designed for testing the calibration of the indicator and for checking roughly the resistance of the leads and the thermocouples.

When testing an indicator, it is connected by means of the 1-ohm copper-constantan clip leads furnished with the tester to the binding posts marked "Indicator test" (fig. 10). Since the resistance between the terminals marked "Indicator test" plus the resistance of the 1-ohm leads is exactly equal to the resistance of a Navy standard 2-ohm thermocouple and leads, indicators of any resistance are properly tested.

If there is a change in indication of the indicator when the circuit is completed and with the tester current off, it is due to a difference in temperature between the reference junction in the indicator and the measuring junction in the tester. If this change in reading exceeds  $10^{\circ}\text{C}$ ., time should be allowed for the tester and indicator to come to the same temperature. When the limit of  $10^{\circ}\text{C}$ ., is not exceeded, the error obtained in the comparison test ordinarily will not be more than  $2^{\circ}\text{C}$ .. When proceeding with the test, the pointers of both the indicator and the millimeter of the tester are set to the measuring junction temperature as indicated by the mercury thermometer on the tester.

The tester is designed for testing only one indicator at a time. The connection of two or more indicators in parallel will lead to erroneous results.

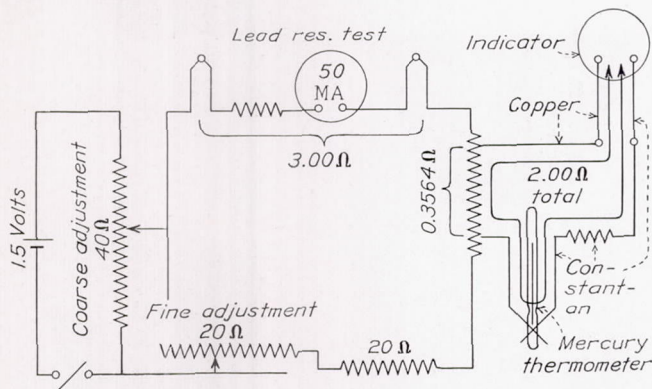

FIGURE 11.—Diagram of electrical connections of tester for copper-constantan thermoelectric thermometers.

### RESISTANCE THERMOMETER

For the measurement of air temperatures on aircraft, thermometers of the resistance type are especially suitable on account of their features of remote indication and short-time lag. The temperature-sensitive element may be located in places or at distances, impossible or impracticable for liquid-in-glass or bimetal thermometers. Although a resistance thermometer may be made to indicate over the range from  $-70$  to  $100^{\circ}\text{C}$ ., no thermometer of the liquid or vapor-pressure type that will operate satisfactorily over this range is known. The winding of the resistance element may be so made that the time lag in air is very much shorter than that of temperature elements of other types. One indicator may be used to indicate successively the temperature of a number of resistance elements by using a selector switch.

The resistance thermometer described in this report was originally designed and constructed for use in the flight testing of airplanes. Instruments of this type have also been used for the indication of air temperature on lighter-than-air ships of the United States Navy, on the National Geographic Society-Army Air Corps stratosphere balloons, and for the determination of temperature of the mixture in gasoline engine intake manifolds.

**Indicator.**—The instrument is essentially an unbalanced Wheatstone bridge arrangement, as shown schematically in figure 12. Figures 13 and 14 are, respec-

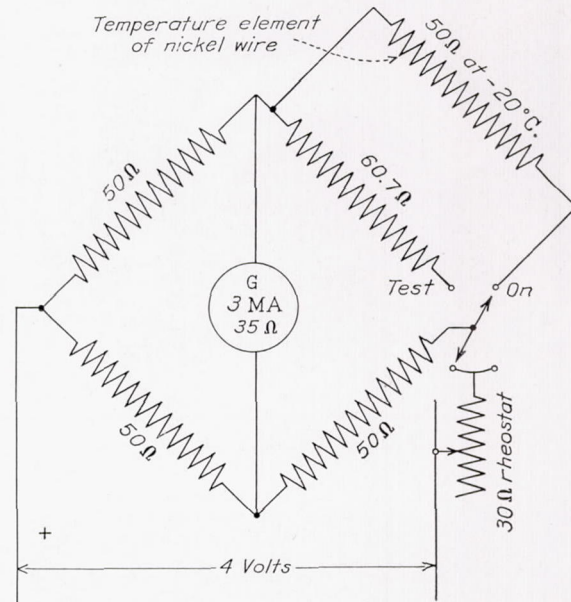

FIGURE 12.—Schematic diagram of resistance thermometer.

tively, a front view and an inside rear view of the indicator unit. The electrical instrument is a Weston Model 269 millimeter, giving a full-scale deflection on 3 milliamperes and having a resistance of approximately 35 ohms. The moving coil of the millimeter is mounted on airplane pivots. If the double amplitude of vibration of the airplane member to which the instrument is fastened exceeds 0.005 inch, shock-absorbing means should be provided to reduce the instrument vibration to or below this value. The zero, or open-circuit, position of the pointer is approximately one-fourth of the length of the scale, from the left, as shown in figure 13. The calibration of the scale is approximately linear.

The bakelite case built around the electrical instrument (fig. 13) houses the 30-ohm rheostat, the switch, and the separable terminals carrying leads to the electrical supply and to the temperature element. The fixed manganin resistances of the bridge are mounted inside the electrical instrument case. The weight of the indicator unit is approximately  $2\frac{3}{4}$  pounds.

For accurate indications it is necessary that the switch be turned occasionally to the test position and the rheo-

stat adjusted to cause the indicator pointer to stand at the test point ( $20^{\circ}\text{C}$ . on fig. 13). When in the test position the switch substitutes a fixed resistance for the temperature element. The value of this fixed resistance is equal to that of the temperature element when it is at the temperature of the test point. Ad-

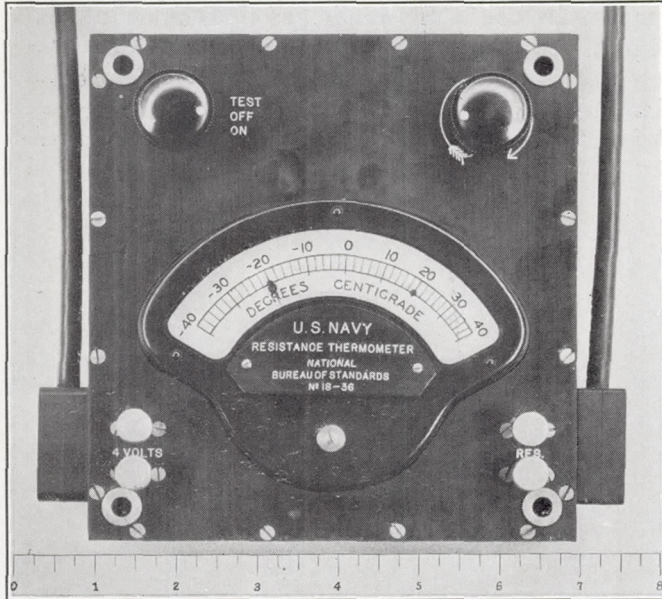

FIGURE 13.—Resistance-thermometer indicator.

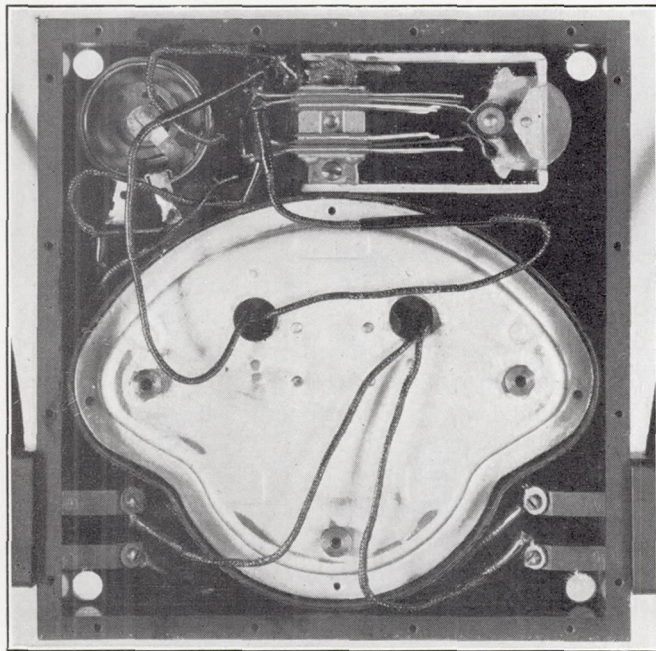

FIGURE 14.—Rear inside view of resistance-thermometer indicator.

justing the rheostat varies the voltage impressed on the bridge. Proper adjustment compensates, exactly at the test point, for variations in the supply voltage and for temperature variations in the resistance of the copper in the moving coil of the electrical instrument. It is obvious that the indications at the balance point

( $-20^{\circ}\text{C}$ . in fig. 13) are also free of errors due to these causes. Assuming that the proper voltage adjustment has been made, the errors due to these causes at points on the scale other than at the test and balance points will be negligible.

**Temperature element.**—Details of a temperature sensitive element designed for strut mounting on an airplane are shown in figure 15. The temperature sensitive part is a single layer of no. 34 gage single silk-covered nickel wire wound on a bakelite tube of approximately  $\frac{1}{4}$ -inch wall thickness. The wire is held onto the tube and protected from moisture by several coats of bakelite varnish. The construction of the bakelite base is clearly shown. The connections between the nickel wires from the element and the copper lead

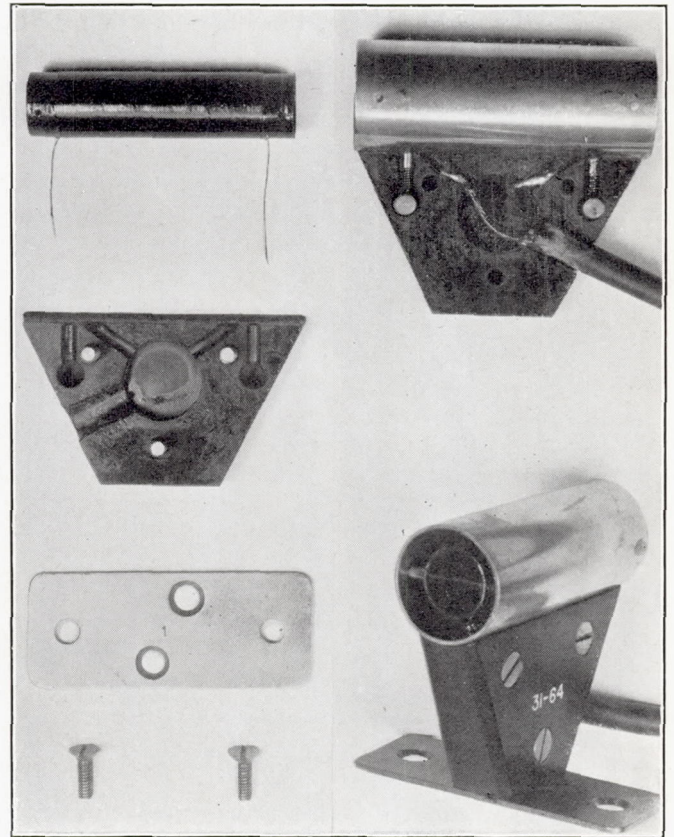

FIGURE 15.—A resistance-thermometer temperature element.

wires are inside the base. The outside nickel-plated tube, which has a diameter of 1 inch and a length of  $2\frac{3}{4}$  inches, serves to protect the element from the direct rays of the sun.

The element should be mounted where its temperature will not be affected by the heat from the engine exhaust. When possible, the leads from the temperature element to the indicator are installed inside the airplane wing covering at the factory. When necessary to make an installation on a finished airplane, a flat duplex lead  $\frac{1}{16}$  inch thick and  $\frac{5}{8}$  inch wide is sometimes used. This flat lead is held under a strip of fabric attached by dope to the airplane strut or wing.

Driver-Harris Grade A nickel wire has been used in the construction of the temperature elements. It has been found that all the wire from any one spool has approximately the same resistivity and temperature coefficient of resistivity. The resistance  $R$  of elements made in the last three years at the National Bureau of Standards (all from one spool) may be expressed by the following equation:

$$R = 55.22 (1 + 4.85T \times 10^{-3} + 6T^2 \times 10^{-6}) \quad (1)$$

in which  $T$  is the temperature of the element in degrees centigrade. The data used for determining the constants of this equation were obtained by a null bridge method, a temperature element of the usual construction being one arm of the bridge. The temperature element was installed in a temperature chamber in front of a fan giving an air current of approximately 17 miles per hour. The electric current in the temperature element was approximately the same as that in the temperature element of circuit shown in figure 12. The temperature of the air in the chamber was held constant by hand regulation, holding the null indicator on zero. The values of the several constant temperatures were determined from an accurately calibrated copper-constantan thermocouple element installed just ahead of the resistance element. The temperature range of  $-70$  to  $40^\circ$  C. was covered in this calibration. The best curve of the form of equation (1) was then fitted to the observed points. Wire from several spools of Driver-Harris Grade A nickel wire has been tested and found to have appreciably different temperature coefficients.

All resistance elements with the exception of those used on the stratosphere flights have been adjusted to a resistance of 60.7 ohms at a temperature of  $20^\circ$  C. The resistance at  $-20^\circ$  C. is 50 ohms. These specified resistances include the resistance of copper lead wires to the element. These leads may be made of no. 16 gage wire, 10 or 20 feet long, the resistance of the two wires being of the order of 0.1 ohm. In use, the difference in temperature between the element and the lead wire is small; since the temperature coefficient of copper is approximately the same as that of the nickel wire used, the error introduced by using the copper lead is considered negligible. If the element and the leads with which it was adjusted are considered as a unit, the units are interchangeable.

**Stratosphere instrument.**—Resistance thermometers with several special features were constructed for use on the National Geographic Society-United States Army stratosphere balloon flights (reference 5). Figures 16 and 17 are photographs of the indicator and the temperature element. The indicator has a range of  $-70$  to  $40^\circ$  C. The indicator face was photographed during the flights at 90-second intervals. A black scale with white graduations and pointer was used because it has been found that clearer photographic records are thus obtained. Since the knob used to switch from the “on”

position to the “test” position in the course of adjusting the voltage did not appear in the photograph it was necessary to install an auxiliary indicator, which may be seen at the upper left-hand corner.

Without special precautions the lag in the temperature element of this instrument would have been pro-

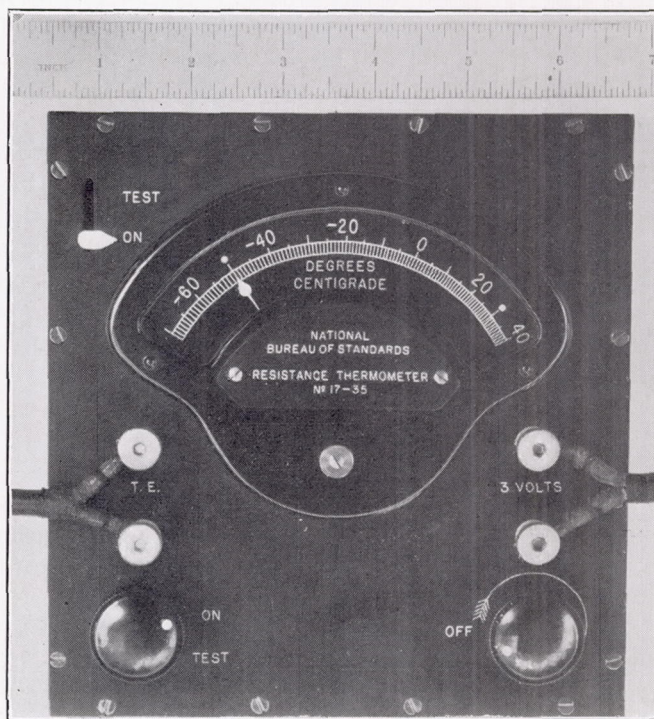

FIGURE 16.—Resistance-thermometer indicator constructed for stratosphere balloon flights.

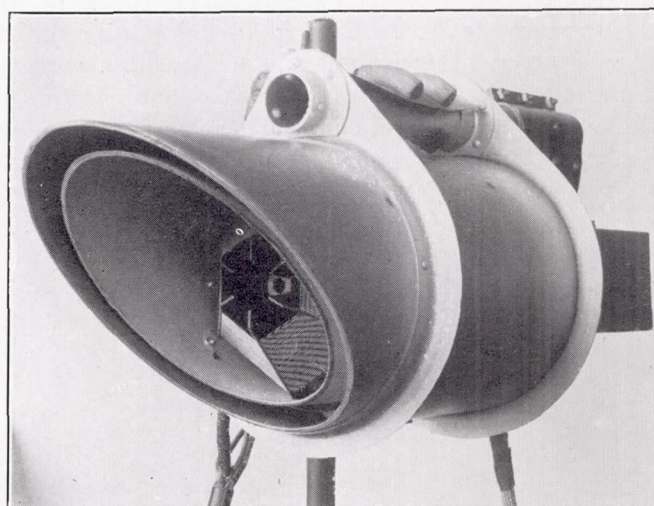

FIGURE 17.—Temperature element of resistance thermometer used on stratosphere flight. This element is ventilated by an electric fan.

hibitive because at the highest altitude reached the air density was only 5 percent of standard sea-level density and there was practically no movement of the balloon relative to the air. As may be seen in figure 17, the wire of the temperature element was wound on an open frame so that practically the entire surface of the wire was

exposed to the air. The element was shielded from the direct rays of the sun by two coaxial fiber tubes, the outer of which was 6 inches in diameter. Ventilation was secured by a fan operated by a small electric motor that drew air through the tube.

**Time lag.**—A detailed discussion of the time lag of thermometers is given by Harper (reference 6). Henrikson (reference 7) describes experimental methods and apparatus for the determination of time-lag constants and gives values of the time-lag constants for various aircraft thermometers.

A convenient method for determining the time-lag constant of air thermometers is to raise the temperature of the element to approximately 60° C. and then suddenly to place it in an air stream at room temperature, measuring with a stop watch the time required for a change in indication between two convenient points on the scale. The time-lag constant  $\lambda$ , in seconds, is defined by the equation,

$$\lambda = \frac{t}{\log_e \frac{T_1 - T_0}{T_2 - T_0}} \quad (2)$$

where  $T_0$  is the temperature of the air stream,  $T_1$  the indication when timing is started,  $T_2$  the indication when timing is stopped, and  $t$  the time in seconds for the indication to change from  $T_1$  to  $T_2$ .

Tests at air speeds of 30 to 60 miles per hour indicate that approximately, the time lag varies inversely as the air speed  $V$ .

$$\lambda_0 = \frac{L}{V} \quad (3)$$

where  $\lambda_0$  is the value of the time-lag constant at the air density  $\rho_0$  and  $L$  is a constant, characteristic of the temperature element. Koning discusses this relation in reference 8. It is evident that at very low air speeds, under a mile or two per hour, convection currents in the air become predominant so that formula (3) does not apply. The value of  $\lambda$  remains finite when  $V=0$ . However, for airplane speeds the convection constant may be neglected.

Smolar (reference 9) gives the variation of  $\lambda$  with air density as

$$\lambda = \lambda_0 \sqrt{\frac{\rho_0}{\rho}} \quad (4)$$

Combining equations (3) and (4).

$$\lambda = \frac{L}{V} \sqrt{\frac{\rho_0}{\rho}} \quad (5)$$

Since the true air speed  $V$  may be expressed as a function of the pitot-static indicated air speed  $V_i$ ,

$$V = V_i \sqrt{\frac{\rho_0}{\rho}} \quad (6)$$

it follows that,

$$\lambda = \frac{L}{V_i} \quad (7)$$

This equation gives  $\lambda$  as a function of the indicated air speed, independent of air density.

If  $V_i$  is expressed in miles per hour and  $\lambda$  in seconds,  $L$  for the resistance element illustrated in figure 15 is equal to approximately 160. At an indicated air speed of 100 miles per hour,  $\lambda$  is 1.6 seconds.

It is of interest to review two physical conceptions of the time-lag constant  $\lambda$ . First, assume that the temperature is changing at a rate which has remained constant for some time (fig. 18). The indication  $T$

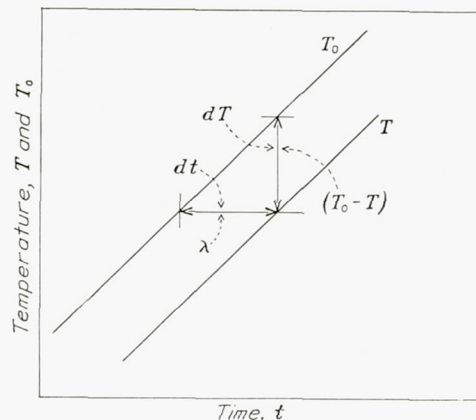

FIGURE 18.—Graphical illustration of time lag of a thermometer in a medium, the temperature  $T_0$  of which is varying at a constant rate. The thermometer indication is  $T$ , the time-lag constant is  $\lambda$ , and the temperature lag is  $T_0 - T$ .

of the thermometer will lag behind the actual temperature  $T_0$ , indicating the temperature that existed  $\lambda$  seconds earlier. The lag in temperature indication,  $T_0 - T$  (in degrees) is the product of the time-lag constant (in seconds) by the rate of change in temperature (in degrees per second). Second, assume that the temperature element is suddenly taken from air at one temperature and placed into air at a different temperature. After  $\lambda$  seconds the indication will still have  $1/e (=0.37)$  times the total temperature difference to go before the new temperature is accurately indicated. The value of  $e$ , the base of the natural logarithm system, is approximately 2.72. The variation in indication with time is given by equation (2) when  $T_1$  is the indication at time  $t=0$  and the indication  $T_2$  at time  $t$ .

**Temperature rise due to  $I^2R$  loss.**—Equation (2) was derived on the assumption that Newton's law of cooling holds for the resistance element; that is, that the rate of heat transfer to or from the element is directly proportional to the difference in temperature between the element and the surrounding air. This law may be expressed by

$$M \frac{dT}{dt} = k(T - T_0) \quad (8)$$

where  $M$  is the heat capacity of the element and  $k$  is a factor of proportionality. In equation (2),  $M/k$  was set equal to the single constant  $\lambda$ , the time-lag constant for the element.

If there is an  $I^2R$  loss in the element maintaining the element at a constant temperature above that of the air, the rate at which heat is lost must equal the rate

at which it is supplied, that is

$$I^2R = k(T - T_o) \quad (9)$$

or with  $k = M/\lambda$ ,

$$I^2R = \frac{M}{\lambda}(T - T_o) \quad (10)$$

The temperature rise due to the heating is then

$$T - T_o = \frac{\lambda}{M} I^2R \quad (11)$$

where  $I$  is the current and  $R$  is the resistance of the element.

The  $I^2R$  loss in the element, calculated from the data given in figure 12, is equal to approximately 0.05 watt. The value of  $M$ , calculated from the dimensions, densities, and specific heats of the parts, is equal to 3.3 watt-seconds per degree centigrade. Then, for the element illustrated in figure 15,

$$T - T_o = \frac{0.05}{3.3} \lambda = 0.015 \lambda \quad (12)$$

or, from equation (7),

$$T - T_o = 0.015 \frac{L}{V_1} \quad (13)$$

The observed value of the time lag of the element in still air with the axis of the tube vertical is 115 seconds. Substituting this value in equation (12), the  $I^2R$  temperature rise is equal to  $1.7^\circ$  C. From equation (13) the rise at 50 miles per hour is equal to  $0.05^\circ$  C. Both the time lag and the  $I^2R$  temperature rise decrease rapidly with increasing air speed.

**Speed correction.**—The results of flight tests on high-speed airplanes indicate that thermometers exposed in the air stream give increasing readings with increasing air speed, the air temperature remaining constant. The correction  $C$  independent of the air density, when expressed as a function of the indicated air speed, is

$$C = -SV_i^2 \quad (14)$$

where  $S$  is a constant, characteristic of the element, and  $V_i$  is the pitot-static indicated air speed. If  $V_i$  is expressed in miles per hour and  $C$  in degrees centigrade,  $S$  for the element illustrated in figure 15 is equal to approximately  $80 \times 10^{-6}$ . At an indicated air speed of 200 miles per hour, the correction amounts to  $3.2^\circ$  C. and should be subtracted from the observed readings. This speed error, which is common to all types of thermometers, is discussed in reference 8.

**Laboratory tests and performance.**—Resistance thermometers are tested for scale errors in an air bath. The temperature element is placed in a chamber in which a fan provides a positive flow of air past the element. The temperature of the air around the element is held constant within narrow limits for several minutes before each reading. This temperature is measured by a calibrated thermocouple placed close to the resistance element. The scale errors, as determined by this method, do not ordinarily exceed  $0.5^\circ$  C.

The method of determining the time-lag constant of the instrument has been discussed.

The effect of change in temperature of the indicator is eliminated for all practical purposes when the voltage is properly adjusted at any given indicator temperature.

#### SUPERHEAT METERS

The term "superheat" as used in relation to lighter-than-air craft is defined as the temperature of the lifting gas minus the temperature of the outside air. The importance of a knowledge of superheat is evident when the dependence of the lift of a balloon or airship on this temperature difference is considered. The additional lift due to positive superheat is equal to the weight of the air that is forced out of the envelope by the increase in temperature. Strother and Eaton (reference 10) discuss the effect of superheat on the lift of an airship.

The superheat may be determined by separately measuring the outside air temperature and the gas temperature, but it is more convenient, and usually more accurate, to read this temperature difference directly on a superheat meter. Two general types of superheat meters have been constructed at the National Bureau of Standards for use on United States Navy airships, the thermoelectric type and the resistance type. Each type will be described.

**Thermoelectric type superheat meter.**—The essential details of thermoelectric type superheat meter installation using copper-constantan couples are shown in figure 19. By the use of a selector switch, both forward and after readings are obtained on the same indicator. The indicator is a Weston model 440 galvanometer of 3.5 ohms resistance, giving full-scale deflection on  $132 \times 10^{-6}$  amperes. A photograph of the parts of an instrument for indication of aft superheat only is given in figure 20.

Excessive temperature lag at the junctions is avoided by joining 6-inch lengths of no. 24 gage copper and constantan wires to the no. 16 gage copper and constantan wires and forming the actual junctions by joining the smaller wires. It is essential that the air junction be protected from the direct rays of the sun.

**Calculation of errors.**—Fortunately the two largest errors in a superheat meter of the thermoelectric type can be made approximately to cancel each other, by proper proportioning of the copper resistance and constantan resistance of which the circuit is composed. These errors are due to (1) the increase in thermoelectric power  $dE/dT$  with increase in air temperature and (2) the increase in resistance of copper in the circuit with increase in air temperature. The compensation is based on the assumption that the galvanometer lead wires and air junction are at the same temperature. If the installation cannot be arranged so that this condition is approximately realized, the errors may amount to as much as 5 percent.

(1) The e. m. f.—temperature relation for a Leeds & Northrup copper-constantan thermocouple as derived from test results obtained at the National Bureau of Standards between the temperatures of  $-20$  and  $120^{\circ}$  F. may be expressed as follows:

$$E = 21.4 T_2 (1 + 0.00058 T_2) - 21.4 T_1 (1 + 0.00058 T_1) \quad (15)$$

where  $E$  is the e. m. f. in microvolts and  $T_1$  and  $T_2$  are

ment and nearer the temperature at which the instrument is calibrated. Substituting  $\Delta T$  for  $(T_2 - T_1)$ , this equation may be written as follows:

$$E = 21.4 \Delta T [1 + 0.00058 (2 T_1 + \Delta T)] \quad (16)$$

It should be noted that  $\Delta T$  is the superheat when the thermocouples form part of a superheat meter. It

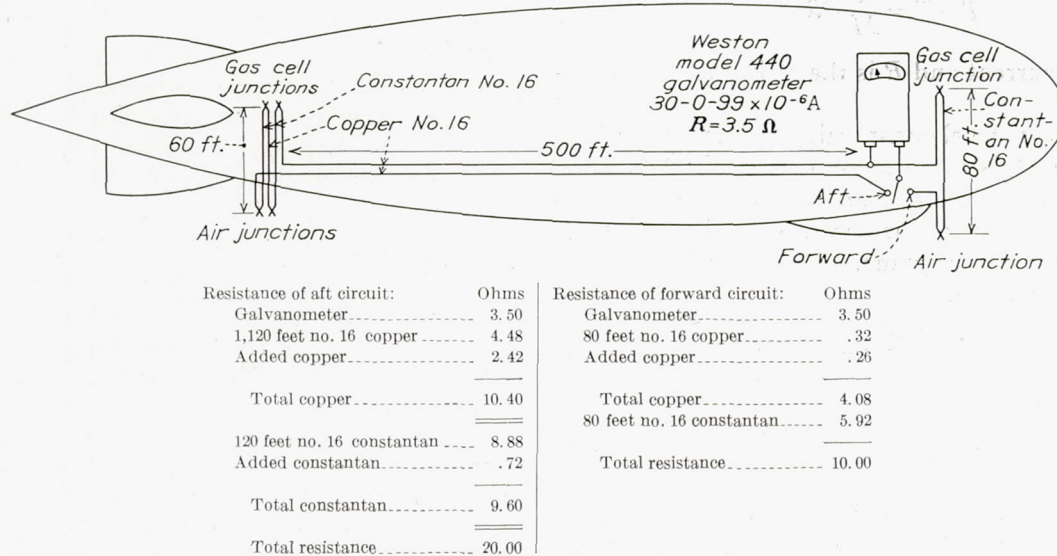

FIGURE 19.—Details of a superheat meter for indicating, on a single indicator, the superheat in the forward and after gas cells.

the temperatures of the air and gas junctions, respectively, in degrees Fahrenheit, above a base temperature of  $50^{\circ}$  F. A base temperature of  $50^{\circ}$  F., rather than  $0^{\circ}$  F., is chosen because the higher temperature is nearer the middle of the operating range of the instru-

is seen that  $E$  is a function of the air-junction temperature  $T_1$  as well as of the superheat  $\Delta T$ .

(2) The resistance of the circuit is

$$R = R_{50} (1 + N \alpha T_1) \quad (17)$$

where  $R$  is the resistance when the entire circuit is at a temperature  $T_1^{\circ}$  F. above  $50^{\circ}$  F., in ohms;  $R_{50}$ , is the resistance of the circuit at  $50^{\circ}$  F., in ohms;  $N$ , the ratio of the resistance of the copper in the circuit to the total resistance of the circuit; and  $\alpha = 0.00222$  per degree Fahrenheit, the temperature coefficient of resistance of copper, at  $50^{\circ}$  F. The temperature coefficient of resistance of the constantan is assumed to be zero.

The indication is also affected in opposite directions by changes in the temperature of the hairsprings and permanent magnet of the galvanometer. These two effects combined may be called the temperature coefficient of the instrument as an ammeter. It averages  $+0.0001$  per degree Fahrenheit for several instruments which have been tested. Since no definite information, except that the value is small, is available on the value of this coefficient for the Weston Model 440 galvanometer, the value will be assumed to be zero.

The galvanometer current  $I$ , in microamperes, as determined from equations (16) and (17) is

$$I = \frac{E}{R} = \frac{21.4 \Delta T [1 + 0.00058 (2 T_1 + \Delta T)]}{R_{50} (1 + 0.00222 N T_1)} \quad (18)$$

If  $T_1 = 0$ ,

$$I = \frac{21.4 \Delta T (1 + 0.00058 \Delta T)}{R_{50}} \quad (19)$$

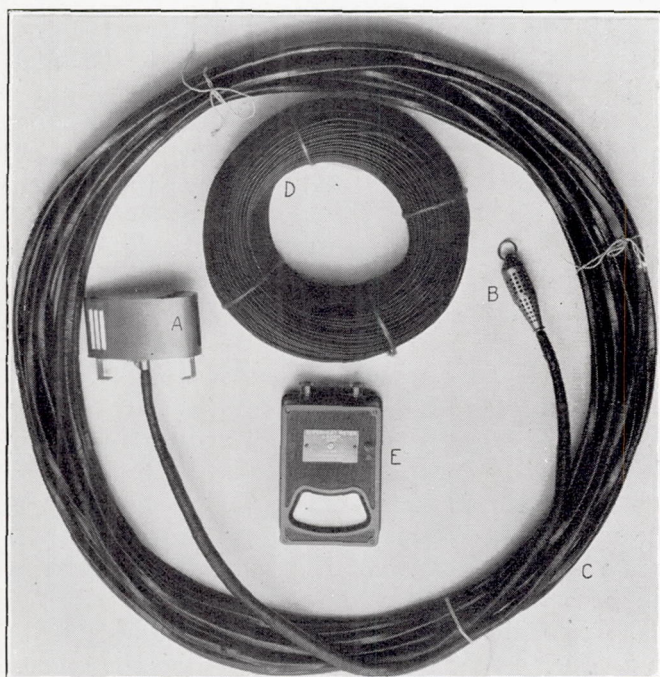

FIGURE 20.—A thermoelectric-type superheat meter, complete with air element (A), gas-cell element (B), and connecting wire (C and D). This instrument was installed in an after cell on the U. S. S. Los Angeles.



The instrument scale is constructed according to equation (19). Equation (18) indicates that the calibration is not independent of  $T_1$ . However, if

$$N = \frac{2 \times 0.00058}{0.00222} = 0.52 \quad (20)$$

the indication, neglecting second-order terms, is correct for all values of  $T_1$ . Thus the resistance of the circuit should consist of 52 percent copper and 48 percent constantan. The errors for rather large departures from this ratio are not serious, but there is no reason why the ratio cannot be at least approximated. The requirement is not inconsistent with the practice of selecting a galvanometer that has a resistance equal to that of the external circuit, since the galvanometer resistance is all copper and the resistance external to the galvanometer is mainly constantan.

It is possible to proportion the copper and the constantan in the aft circuit of the instrument outlined in figure 19, so that  $N=0.52$  and the error in indication is zero. For the forward instrument the optimum ratio could not be conveniently attained (without the use of larger lead wires). For it,  $N=0.41$ ; and the error in indication is -1 percent of the indication for an air temperature of 90° F. and +1 percent for an air temperature of 10° F.

**Resistance-type superheat meter.**—A resistance-type superheat meter has several advantages over the thermoelectric-type instrument, mainly the possibility of using a more rugged electrical instrument.

The schematic diagram of the essentials of a superheat meter of the resistance type is shown in figure 21. The temperature elements,  $e$  and  $f$ , are made of no. 34 gage Driver-Harris Grade A nickel wire and have a resistance of 30 ohms at a temperature of 0° F. The temperature coefficient of resistance of this wire has been determined as described in the section on resistance thermometers. The resistance of the 30-ohm elements is

$$R = 30(1 + 2.82T \times 10^{-3} + 2T^2 \times 10^{-6}) \quad (21)$$

in which  $T$  is the temperature in degrees Fahrenheit.

TABLE III.—RESULTS OF TESTS TO DETERMINE THE BEST COMBINATION OF RESISTANCES FOR THE RESISTANCE TYPE SUPERHEAT METER

Air temperature (°F.)	Super-heat (°F.)	Errors, °F., produced by using resistance values as designated in fig. 21				
		$a=b=500$ $c=770\Omega$	$a=b=1500$ $c=200\Omega$	$a=b=1800$ $c=150\Omega$	$a=b=2000$ $c=124\Omega$	$a=b=4000$ $c=0\Omega$
-40.3	0	0	0	0	0	0
	13.6	-.3	-.3	0	-.1	.7
	27.0	-.5	-.4	-.2	-.2	1.2
0	40.3	-.7	-.8	-.4	-.2	1.2
	-13.3	.1	0	0	0	-.3
	0	0	0	0	0	0
39.2	13.2	-.1	-.1	-.2	0	0
	26.3	-.3	-.3	-.1	-.1	.2
	39.3	-.4	-.2	-.1	-.1	.1
	-13.0	0	-.1	0	0	0
	0	0	0	0	0	0
77.3	12.8	.1	.1	.2	.1	0
	25.5	.3	.2	.1	.2	-.2
	38.1	.4	.3	.3	.3	-.5
	-12.6	-.2	-.2	-.1	-.1	.4
	0	0	0	0	0	0
77.3	12.5	.3	0	-.1	0	-.5
	24.9	.4	.1	.1	-.1	-1.1
	37.1	.8	.2	.1	-.1	-.8

The circuit shown in figure 21 was established with dial resistance boxes, setting the resistances  $e$  and  $f$  to correspond to various temperatures. The resistance  $c$  in series with the galvanometer was adjusted on each trial to make the range of the superheat meter -15 to 45° F. The errors determined by this method and reported in table III show that for certain ratios of the resistance arms the errors are reduced to negligible values. It appears from the table that 2,000 ohms each in the arms  $a$  and  $b$ , offers the best combination.

Table III shows that the resistance ratios are not critical, three of the five trials all showing negligible errors. Low resistances at  $a$  and  $b$  cause negative errors at low air temperatures and positive errors at high air temperatures; while high resistances at these places cause errors of the opposite sign. The tests were made with a Weston Model 301 instrument having a resistance of approximately 60 ohms and a range of 50-0-150 microamperes. The proposed range of the superheat meter is -15 to 45° F. The circuit was designed for use on

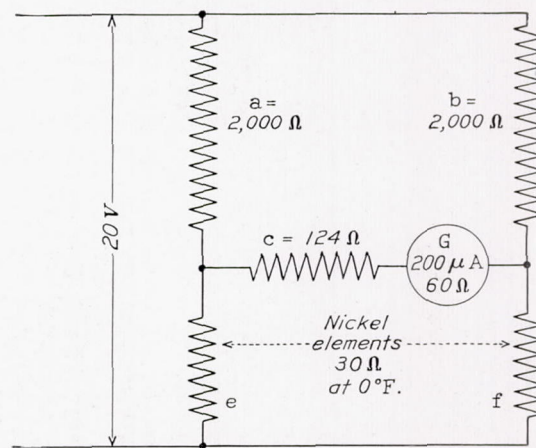

FIGURE 21.—The basic circuit of a resistance-type superheat meter. The fixed resistances of the bridge are  $a$  and  $b$ ; the air and gas elements are  $e$  and  $f$ .

a 20- to 24-volt battery supply. If designed for 110 volts, with a corresponding increase in resistance, and decrease of current in the temperature sensitive elements, there would be the advantage of relatively less voltage drop in the long leads sometimes required.

Two superheat meters of the resistance type, which have been constructed at the National Bureau of Standards for the U. S. Navy, are shown in figures 22 and 23. The instruments are essentially the same except that one has space provided inside the instrument for a 22½ volt radio B battery while the other must be supplied with current from an external source.

Figure 24 is a diagram of connections applicable to both instruments. The connections are fundamentally the same as shown in figure 21 with the addition of two manganin resistances and a triple-pole double-throw switch arranged for checking the supply voltage. When the switch is in the "test" position, the temperature elements in the bridge circuit are replaced by two

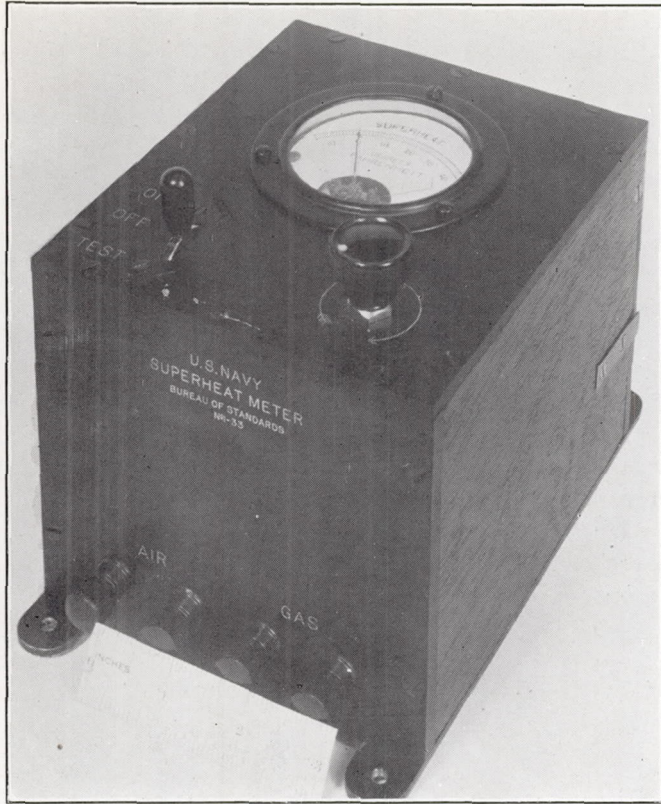

FIGURE 22.—Resistance-type superheat meter with self-contained battery.

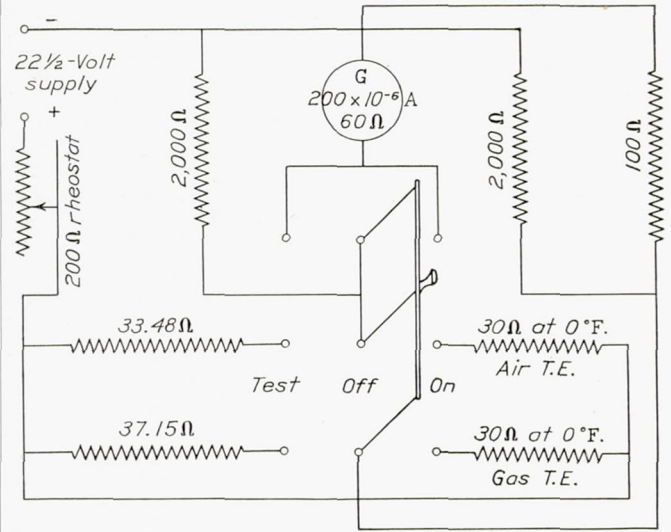

FIGURE 24.—Diagram of connections for a superheat meter of the resistance type.

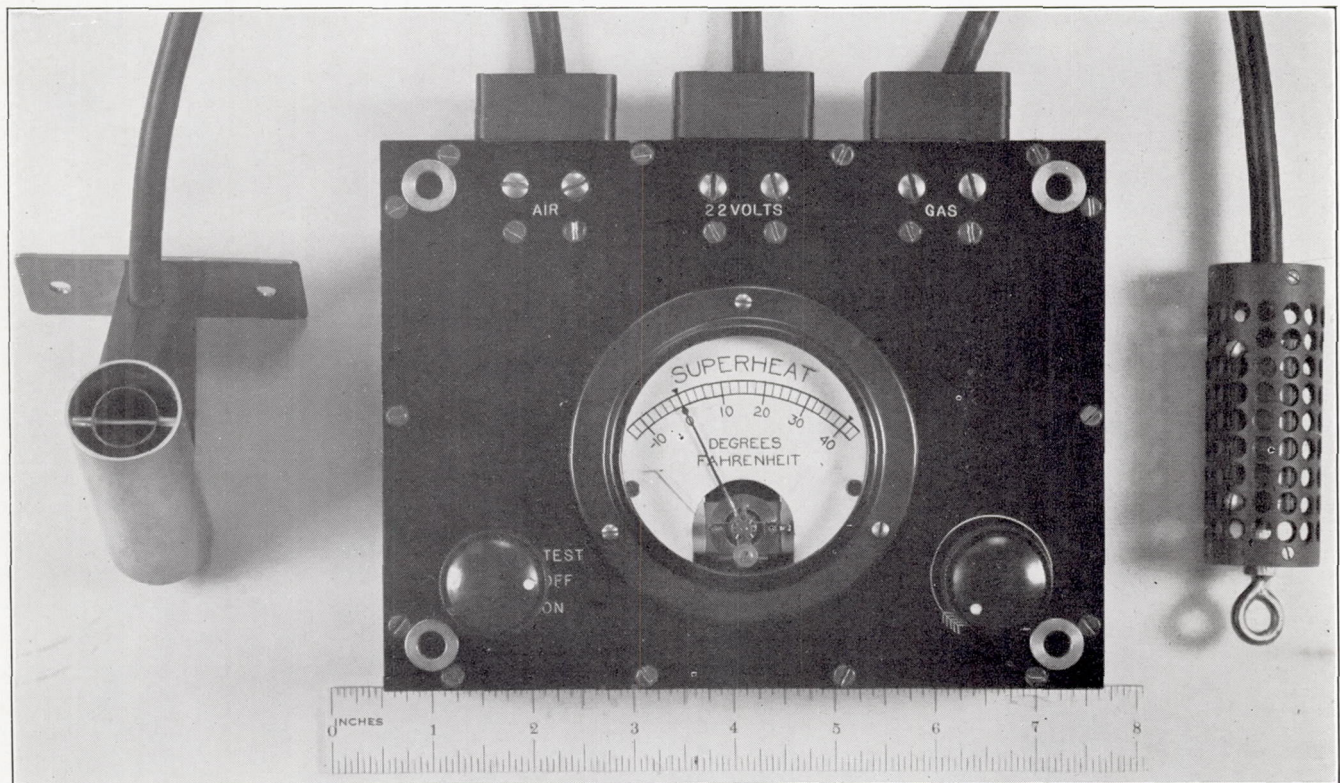

FIGURE 23.—Resistance-type superheat meter with air- and gas-cell elements.

manganin resistances of 33.48 ohms and 37.15 ohms. These values are the resistances of the 30-ohm elements at temperatures of 40 and 80° F., respectively. The 40° F. resistance was selected for the low-value checking resistance because 40° F. is near the average temperature of the air in which an airship operates. The indicator pointer should be adjusted to stand on the zero mark with current off. The rheostat serves to adjust the supply voltage so that the pointer stands on the 40° F. superheat mark when the switch is in the test position. The reference marks at 0 and 40° F. superheat can be seen on the scales of both instruments (figs. 22 and 23).

It should be noted that the indication at zero superheat is independent of battery voltage and that the percentage error at other indications is equal to the percentage variation from the correct voltage adjustment. Adjustment for battery voltage, as described, serves to compensate for the effect of variations in the temperature of the indicator. This fact is obvious when it is noted that the indicator is adjusted to indicate correctly at 40° F. superheat regardless of the resistance of the galvanometer circuit.

The construction of the temperature elements is similar to that described for the resistance thermometer. A photograph of the gas-temperature element is shown in figure 23. The gas-cell element is mounted coaxially with a perforated bakelite outer shell. It is

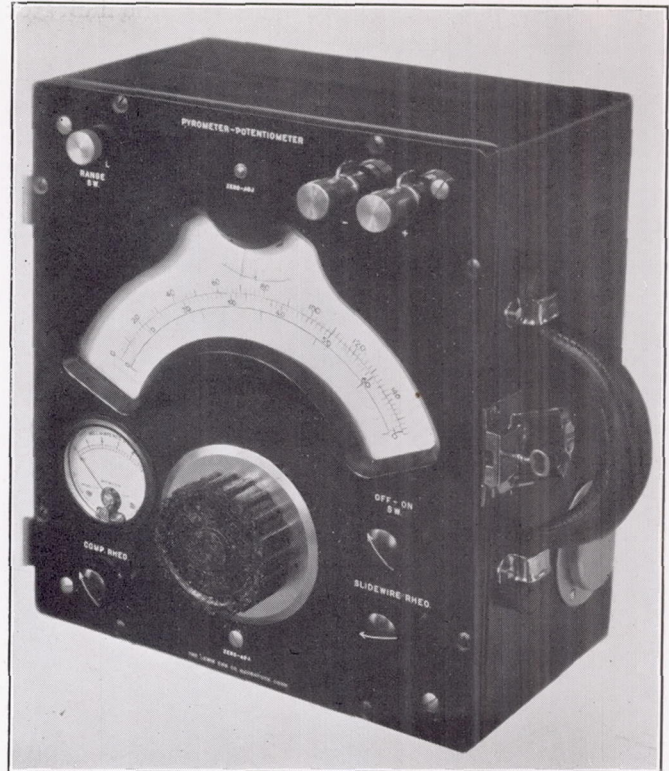

FIGURE 25.—A potentiometer temperature indicator.

designed to be suspended in the gas cell the superheat of which is to be measured.

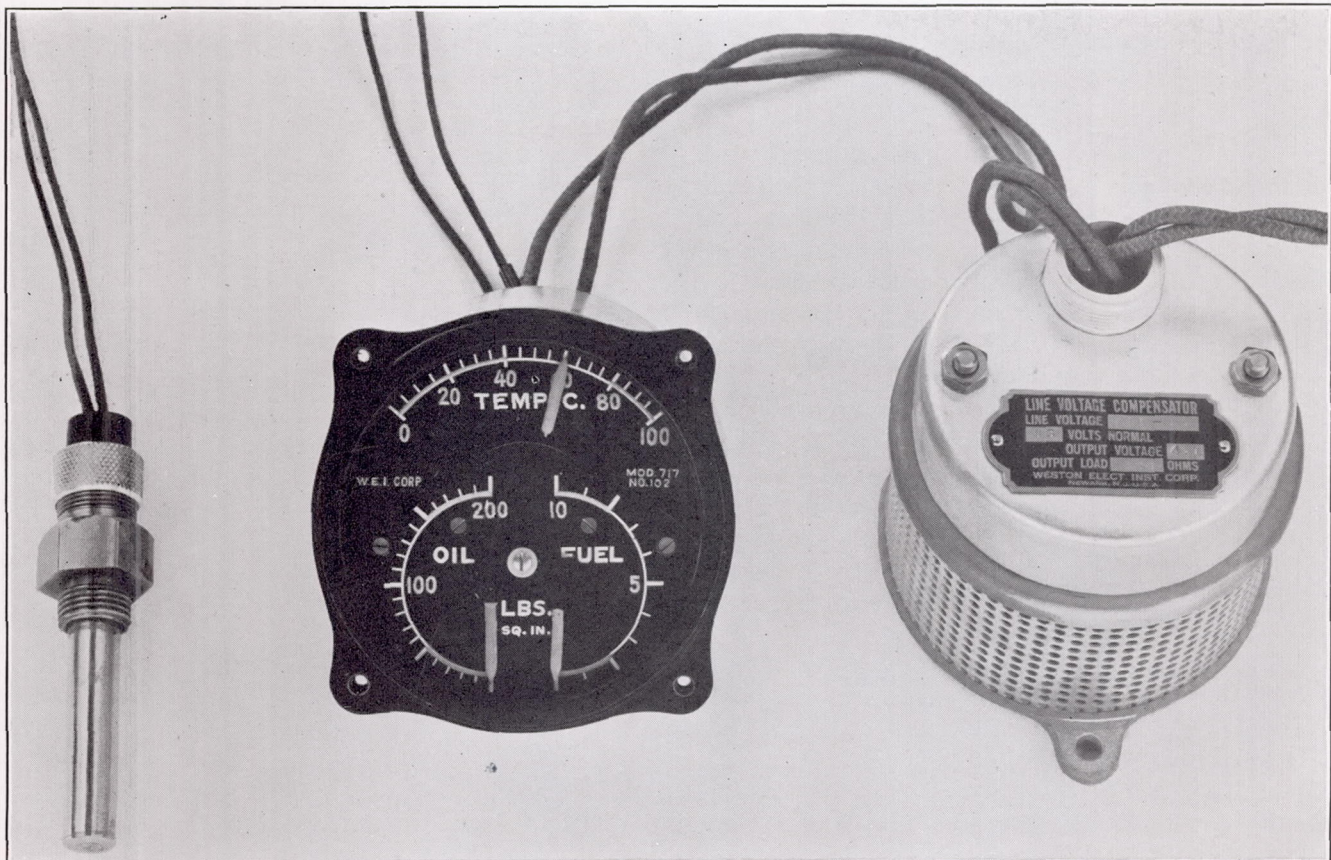

FIGURE 26.—Engine gage unit incorporating a resistance-type oil-temperature indicator.

The length of the copper wires between the indicator and the gas-cell element are usually longer than those between the indicator and the air element and their resistance may be an appreciable part of 30 ohms, but the temperature coefficient of copper is practically the same as that of nickel and if most of the wire is inside the envelope at an average temperature not appreciably different from that of the gas-cell element, the error caused by the lead wires will be negligible.

#### OTHER INSTRUMENTS

Not all types of electrical thermometers in use on aircraft today are described in this report. Among the types not described, a potentiometer indicator made

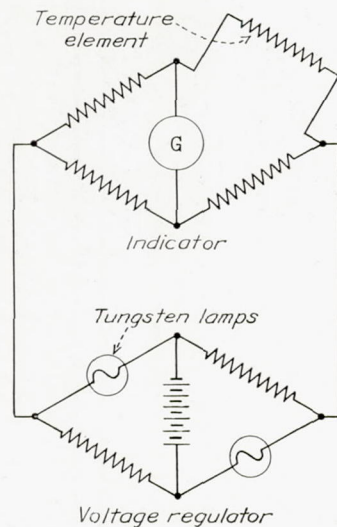

FIGURE 27.—Diagram of connections of resistance-type thermometer with a voltage regulator.

by the Lewis Engineering Company might be mentioned. A photograph of this instrument is shown in figure 25. This instrument may be used as a standard for testing thermoelectric indicators in the field and may be used as the indicator on large aircraft, where the saving in weight of leads, effected by the use of the potentiometer instrument, may be enough to warrant the use of the heavier indicating apparatus.

The Weston Electrical Instrument Corporation has developed a resistance thermometer of a range suitable for measuring radiator cooling liquid or oil tempera-

ture. It is of the unbalanced Wheatstone bridge type. A photograph of the instrument, built into an engine gage unit, is shown in figure 26. Figure 27 is a diagram of connections, showing the details of the voltage regulator that compensates for variations in battery voltage.

The General Electric Company has used a crossed-coil ohmmeter type instrument as the indicator in a resistance thermometer. An instrument of this type was used on the National Geographic-Army Air Corps stratosphere flight; it had a temperature element similar to that shown in figure 17.

NATIONAL BUREAU OF STANDARDS,  
WASHINGTON, D. C., December 15, 1936.

#### REFERENCES

1. Sontag, Harcourt, and Brombacher, W. G.: Aircraft Power-Plant Instruments. T. R. No. 466, N. A. C. A., 1933.
2. Roeser, Wm. F., and Wensel, H. T.: Methods of Testing Thermocouples and Thermocouple Materials. Bur. Standards Jour. Res., vol. 14, no. 3, March 1935, p. 247.
3. Roeser, Wm. F., Dahl, A. I., and Gowens, G. J.: Standard Tables for Chromel-Alumel Thermocouples. Bur. Standards Jour. Res., vol. 14, no. 3, March 1935, p. 239.
4. National Research Council: International Critical Tables, vol. V. McGraw-Hill Book Co., Inc., 1929, p. 58.
5. Stevens, Albert W.: The Scientific Results of the World-Record Stratosphere Flight. The National Geographic Magazine, vol. LXIX, no. 5, May 1936, p. 693.
6. Harper, D. R.: Thermometric Lag. Bur. Standards Bul., vol. 8, no. 4, 1912, p. 659.
7. Henrickson, H. B.: Thermometric Lag of Aircraft Thermometers, Thermographs and Barographs. Bur. Standards Jour. Res., vol. 5, no. 3, September 1930, p. 695.
8. Koning, C.: The Indication of Thermometers in Moving Air. Report no. A322 De Ingenieur (Amsterdam) 1932, no. 45.
9. Smolar, Vaclav: Determination de la Temperature de l'Air Pendant les essais en vol. Aero. Res. Inst., Prague, Czechoslovakia, vol. 6, no. 18, 1932, p. 37. (With French Abstract.)
10. Strother, D. H. and Eaton, H. N.: A Superheat Meter or Differential Thermometer for Airships. Tech. Paper No. 359, Bur. Standards, 1927.
11. Geyer, Wilhelm: A Bridge for Measurement of Temperature Difference with Electric Resistance Thermometers. Archiv für Elektrotechnik, vol. XXV, no. 7, July 15, 1931, p. 476.





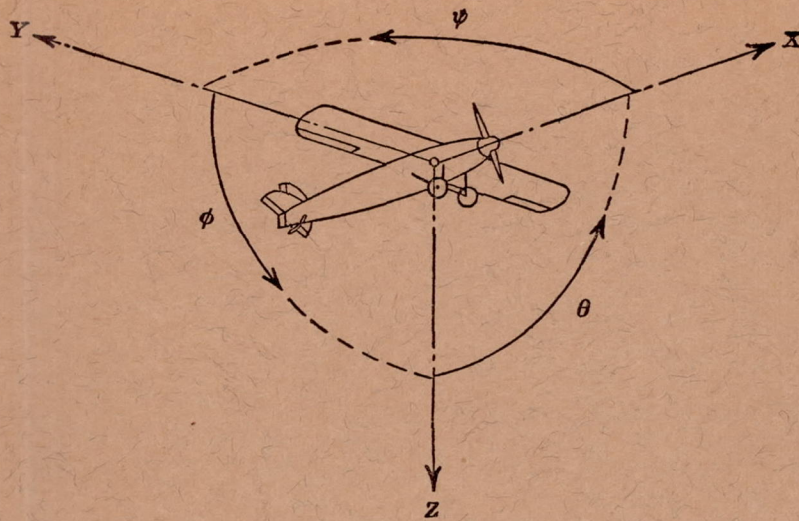

Positive directions of axes and angles (forces and moments) are shown by arrows

Axis		Force (parallel to axis) symbol	Moment about axis			Angle		Velocities	
Designation	Sym- bol		Designation	Sym- bol	Positive direction	Designa- tion	Sym- bol	Linear (compo- nent along axis)	Angular
Longitudinal	X	X	Rolling	L	Y → Z	Roll	$\phi$	u	p
Lateral	Y	Y	Pitching	M	Z → X	Pitch	$\theta$	v	q
Normal	Z	Z	Yawing	N	X → Y	Yaw	$\psi$	w	r

Absolute coefficients of moment

$$C_l = \frac{L}{qbS}$$

(rolling)

$$C_m = \frac{M}{qcS}$$

(pitching)

$$C_n = \frac{N}{qbS}$$

(yawing)

Angle of set of control surface (relative to neutral position),  $\delta$ . (Indicate surface by proper subscript.)

#### 4. PROPELLER SYMBOLS

$D$ , Diameter

$p$ , Geometric pitch

$p/D$ , Pitch ratio

$V'$ , Inflow velocity

$V_s$ , Slipstream velocity

$T$ , Thrust, absolute coefficient  $C_T = \frac{T}{\rho n^2 D^4}$

$Q$ , Torque, absolute coefficient  $C_Q = \frac{Q}{\rho n^2 D^5}$

$P$ , Power, absolute coefficient  $C_P = \frac{P}{\rho n^3 D^5}$

$C_s$ , Speed-power coefficient  $= \sqrt[5]{\frac{\rho V'^5}{P n^2}}$

$\eta$ , Efficiency

$n$ , Revolutions per second, r.p.s.

$\Phi$ , Effective helix angle  $= \tan^{-1}\left(\frac{V}{2\pi r n}\right)$

#### 5. NUMERICAL RELATIONS

1 hp. = 76.04 kg-m/s = 550 ft-lb./sec.

1 metric horsepower = 1.0132 hp.

1 m.p.h. = 0.4470 m.p.s.

1 m.p.s. = 2.2369 m.p.h.

1 lb. = 0.4536 kg.

1 kg = 2.2046 lb.

1 mi. = 1,609.35 m = 5,280 ft.

1 m = 3.2808 ft.

