

REPORT 931

CORRELATION OF CYLINDER-HEAD TEMPERATURES AND COOLANT HEAT REJECTIONS OF A MULTICYLINDER, LIQUID-COOLED ENGINE OF 1710-CUBIC-INCH DISPLACEMENT

By BRUCE T. LUNDIN, JOHN H. POVOLNY, and LOUIS J. CHELKO

SUMMARY

Data obtained from an extensive investigation of the cooling characteristics of four multicylinder, liquid-cooled engines have been analyzed and a correlation of both the cylinder-head temperatures and the coolant heat rejections with the primary engine and coolant variables was obtained. The method of correlation was previously developed by the NACA from an analysis of the cooling processes involved in a liquid-cooled-engine cylinder and is based on the theory of nonboiling, forced-convection heat transfer. The data correlated included engine power outputs from 275 to 1860 brake horsepower; coolant flows from 50 to 320 gallons per minute; coolants varying in composition from 100 percent water to 97 percent ethylene glycol and 3 percent water; and ranges of engine speed, manifold pressure, carburetor-air temperature, fuel-air ratio, exhaust-gas pressure, ignition timing, and coolant temperature. The effect on engine cooling of scale formation on the coolant passages of the engine and of boiling of the coolant under various operating conditions is also discussed.

The results of this analysis indicated that the correlation method is applicable to multicylinder, liquid-cooled engines of the type investigated and permits the prediction of the cylinder-head temperature between the exhaust valves within approximately $\pm 12^\circ F$ and of the coolant heat rejection with an accuracy of ± 5 percent for any operating condition within the range of the investigation.

INTRODUCTION

An investigation of the cooling characteristics of reciprocating aircraft engines is of importance in order to insure satisfactory engine performance at extreme conditions of operation. A considerable amount of data on the cooling characteristics of various air-cooled engines has been published by various investigators but little data have been published on the cooling characteristics of liquid-cooled engines.

An extensive research program to determine the cooling characteristics of liquid-cooled engines was therefore instituted at the NACA Cleveland laboratory in 1943. The initial phase of this program consisted of an investigation conducted on a single-cylinder engine to provide data for a fundamental study of the heat-transfer processes involved. The final results of this investigation are reported in reference 1 in which an analysis, based on the theory of nonboiling forced-convection heat transfer, was made of the cooling

processes in a liquid-cooled engine. This analysis resulted in a semiempirical method, similar to that presented in reference 2 for air-cooled engines, of correlating the cylinder-head temperatures with the primary engine and coolant variables; and this method was successfully applied to the data.

Following the investigation on the single-cylinder engine (reference 1), a comprehensive investigation of the cooling characteristics of a multicylinder engine of 1710-cubic-inch displacement was conducted. The primary data obtained in this investigation are presented in reference 3 in the form of plots of the cylinder temperatures and the coolant heat rejections against the basic engine and coolant variables. In order to determine the applicability of the correlation method of reference 1 to a multicylinder engine and to obtain in most conveniently applied form a complete formulation of the principal cooling characteristics of liquid-cooled engines, this semiempirical method was employed in slightly modified form to correlate both the cylinder-head-temperature data and the coolant-heat-rejection data of reference 3 with the primary engine and coolant variables. The results of both of these correlations as well as examples of their application to a typical problem are presented herein.

The data used in the correlations presented in this report cover wide ranges of engine and coolant conditions including engine power outputs from 275 to 1860 brake horsepower, coolant flows from 50 to 320 gallons per minute, and coolants composed of ethylene glycol-water mixtures ranging in composition from 100 percent water to 97 percent ethylene glycol and 3 percent water.

APPARATUS AND PROCEDURE

The data used in this analysis were obtained from V-1710 engines set up on a dynamometer stand and are presented in curve form in reference 3. The data used in the correlation of cylinder-head temperatures were obtained from four engines that are designated engines A, B, C, and D in reference 3 and herein. Data for the correlation of coolant-heat rejections were obtained from engine D only; data from engines A, B, and C are not included for this correlation because the experimental technique used for these engines was not sufficiently refined to provide heat-rejection data of the accuracy required for this analysis. The engine models used are 12-cylinder, liquid-cooled, V-type engines with a displacement of 1710 cubic inches, a 5.5-inch bore, and a

6.0-inch stroke. The compression ratio is 6.65 and the engines are fitted with single-stage gear-driven superchargers having a gear ratio of 9.6:1 and an impeller diameter of 9.5 inches. The standard ignition system is timed to fire the intake spark plugs 28° B.T.C. and the exhaust spark plugs 34° B.T.C. The valve overlap extends over a period of time equivalent to 74° rotation of the crankshaft.

The cylinder-head temperatures were measured by iron-constantan thermocouples installed in each cylinder between the exhaust valves, between the intake valves, and in the exhaust spark-plug boss at the locations shown in figure 1 and according to the method described in reference 3.

A schematic diagram of the cooling system is shown in figure 2. Copper-constantan thermocouples, differentially connected to a portable precision-type potentiometer, were installed at the locations shown in figure 2 for the purpose of measuring the coolant temperature rise across the engine and the coolant cooling-water temperature rise across the coolers. The coolant flow was measured by means of a venturi installed in the main coolant line and the coolant cooling-water flow was measured with a calibrated rotameter installed in the cooling-water line. Further details of the instrumentation and a description of the general setup and auxiliary equipment are given in reference 3.

A summary of the engine and coolant conditions covered by the data used for both the cylinder-head-temperature and heat-rejection analyses is given in table I. In order to isolate the effect of the engine and coolant variables on both the cylinder-head temperatures and the coolant heat rejections, one of the conditions was varied in each of the tests, while, in general, all the others were held constant. The tests on engine A covered typical engine operating conditions varying from cruise to take-off power and included data for several

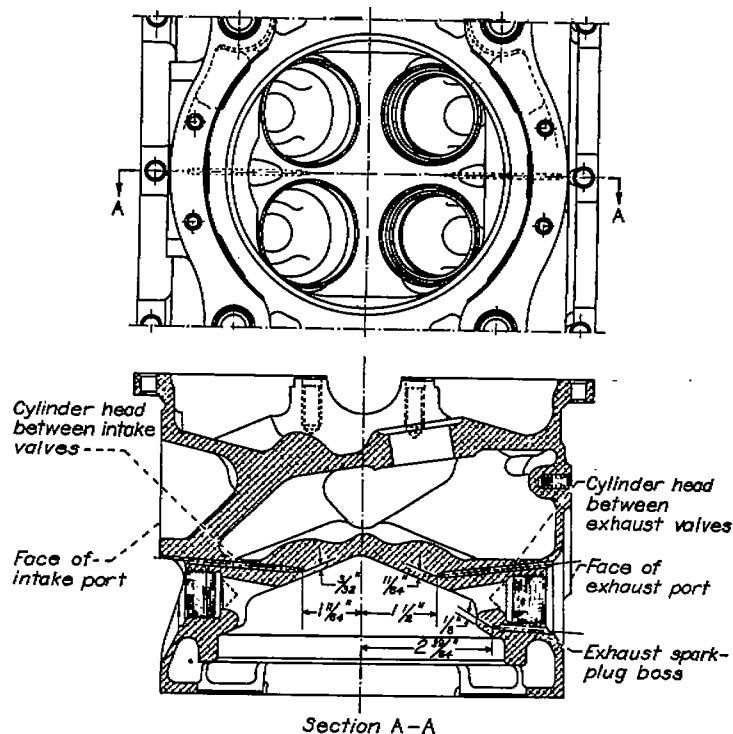

FIGURE 1.—Installation of cylinder-head thermocouples.

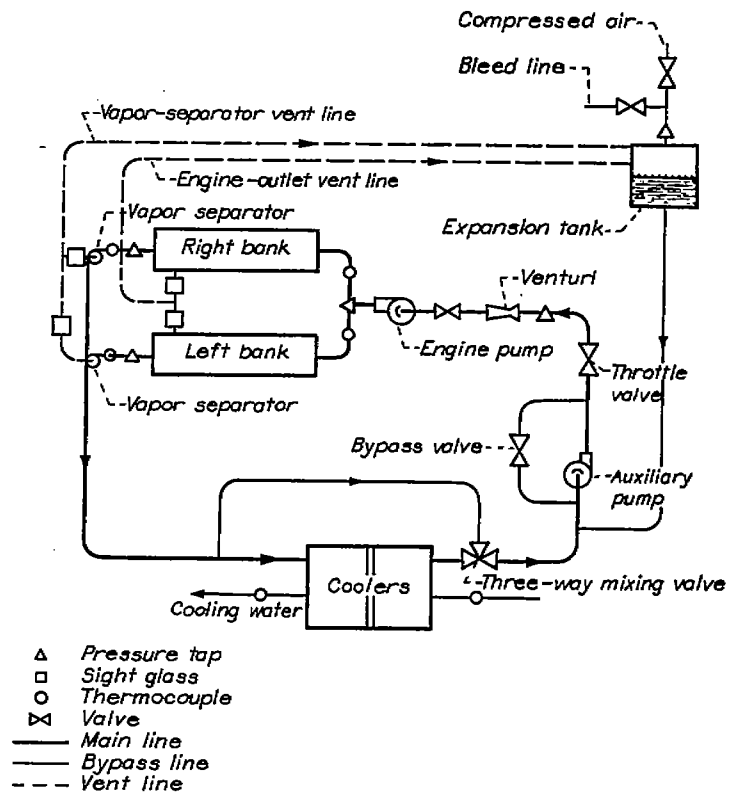

FIGURE 2.—Schematic diagram of engine coolant system.

coolant flows and temperatures and a range of engine coolant-outlet pressures from 10 to 30 pounds per square inch gage. The effects of coolant temperature and engine power on the cylinder temperatures were further determined in the part of the investigation conducted on engine B. Tests in which an aftercooler was mounted on this engine were also made to determine the effects of varying the charge flow, the manifold temperature, the fuel-air ratio, and the aftercooling conditions on engine cooling. The part of the investigation on engines C and D was conducted to extend the range of the cylinder-head-temperature correlation and to provide data essential to both correlations that were not obtained on the other two engines.

ANALYSIS

SYMBOLS

The following symbols are used in this analysis:

\bar{A}	mean area of cylinder wall, (sq ft)
$B_1 \dots B_{10}$	constants
c	specific heat of coolant, (Btu)/(lb) (°F)
c_p	specific heat of air at constant pressure, (Btu)/(lb) (°F)
g	acceleration due to gravity, 32.2 (ft)/(sec ²)
H	heat rejected to coolant, (Btu)/(sec)
J	mechanical equivalent of heat, 778 (ft-lb)/(Btu)
k	thermal conductivity of coolant, (Btu)/(sec) (sq ft) (°F/ft)
k_w	thermal conductivity of cylinder wall, (Btu)/(sec) (sq ft) (°F/ft)
m, n, s	exponents

N	engine speed, (rpm)
Pr	Prandtl number of coolant, $c\mu/k$ (dimensionless)
T_c	carburetor inlet-air temperature, ($^{\circ}\text{F}$)
T_g	effective cylinder-gas temperature, ($^{\circ}\text{F}$)
T_h	average cylinder-head (gas side) temperature, ($^{\circ}\text{F}$)
$T_{h,i}$	average cylinder-head (liquid side) temperature, ($^{\circ}\text{F}$)
T_l	average coolant temperature, ($^{\circ}\text{F}$)
T_m	dry inlet-manifold temperature, ($^{\circ}\text{F}$)
U	supercharger impeller-tip speed, (ft)/(sec)
W_c	engine charge (air plus fuel) flow, (lb)/(sec)
W_l	coolant flow, (lb)/(sec)
x_w	mean thickness of cylinder wall, (ft)
Z	$B_1 \frac{x_w}{k_w A}$, factor that accounts for temperature drop through cylinder head
μ	absolute viscosity of coolant, (lb)/(ft)(sec)

DERIVATION OF CORRELATION EQUATIONS

Consideration of the process by which heat is transferred from the hot gases in the engine cylinder to the coolant in a liquid-cooled engine indicates that the heat must pass through a series thermal path in the following steps: (1) from the gases in the cylinder to the gas-side cylinder wall; (2) through the cylinder wall; and (3) from the liquid side of the cylinder wall to the coolant. In reference 1, the following three equations were presented for this series thermal path:

Cylinder gases to wall

$$H = B_1 W_c^s (T_g - T_h) \quad (1)$$

where T_g is a function of the fuel-air ratio, inlet-manifold temperature, ignition timing, and exhaust pressure.

Through cylinder wall

$$H = \frac{T_h - T_{h,i}}{\frac{x_w}{k_w A}} \quad (2)$$

Cylinder wall to coolant

$$H = B_2 \left(\frac{W_l}{\mu}\right)^m \left(\frac{c\mu}{k}\right)^s k (T_{h,i} - T_l) \quad (3)$$

Cylinder-head-temperature correlation equation.—In order to obtain a single equation expressing the cylinder-head temperature T_h in terms of the primary engine and coolant variables, equations (1) to (3) are combined in such a manner as to eliminate H and $T_{h,i}$. This combination of the three basic equations of heat flow leads to the following cylinder-head-temperature correlation equation:

$$\left[\left(\frac{T_g - T_l}{T_g - T_h} \right) \left(\frac{1}{W_c^s} \right) - Z \right] k (Pr)^s = B_3 \left(\frac{W_l}{\mu} \right)^{-m} \quad (4)$$

where

$$Z = B_1 \frac{x_w}{k_w A}$$

$$Pr = \frac{c\mu}{k}$$

and

$$B_3 = \frac{B_1}{B_2}$$

In equation (4), the coolant-flow factor W_l/μ is the separated variable, the effect of charge flow being incorporated with the temperature parameter. It may be desirable in many cases, however, to separate the effect of charge flow. By rearrangement of equation (4), the following alternative form is obtained in which the charge flow is the separated variable:

$$\left(\frac{T_g - T_h}{T_h - T_l} \right) \left[\left(\frac{B_3}{W_c^s} \right) \left(\frac{\mu^m}{k(Pr)^s} \right) + Z \right] = W_c^{-n} \quad (5)$$

The constant B_3 , the factor Z , and the exponents m , n , and s are determined from the test results and the details of their evaluation are given later in this report. The significance of other factors appearing in the correlation equation or used in the analysis is discussed in a following section. When these factors are evaluated, the relations among T_h and the various engine and coolant operating conditions will be completely defined by equation (4) or (5), and these equations will then serve to correlate and permit the prediction of cylinder-head temperatures for any engine and coolant operating condition.

If modes of heat transfer other than normal forced convection are predominant or if variables other than those contained in the correlation equation have an effect on the cylinder temperatures, the data may be expected to depart from a satisfactory correlation. Two such factors that may be encountered in engine operation are boiling of the coolant and scale build-up on the coolant passages. The effects of these two factors are illustrated in figures to be presented subsequently.

Coolant-heat-rejection correlation equation.—An equation expressing the coolant heat rejection H in terms of the primary engine and coolant variables is obtained by a recombination of equations (1) to (3) in a manner similar to that used for the derivation of the cylinder-head-temperature correlation equation except that, in this case, the variables T_h and $T_{h,i}$ are eliminated. This recombination of the basic equations of heat flow leads to the following heat-rejection correlation equation:

$$\left[B_1 \left(\frac{T_g - T_l}{H} \right) - \left(\frac{1}{W_c^s} \right) - Z \right] k (Pr)^s = B_3 \left(\frac{W_l}{\mu} \right)^{-m} \quad (6)$$

As for cylinder-head temperature correlation equation (4), the coolant-flow factor W_l/μ is the separated variable in this equation and the effect of charge flow is incorporated with the temperature parameter. A rearrangement of equation (6) to place the charge flow as the separated variable gives the following alternative form for the heat-rejection correlation equation:

$$\left[B_1 \left(\frac{T_g - T_l}{H} \right) - \left(\frac{B_3}{W_c^s} \right) \left(\frac{\mu^m}{k(Pr)^s} \right) - Z \right] = W_c^{-n} \quad (7)$$

The values of the various constants appearing in equation (6) or (7) are evaluated from the data in a manner similar to that used for the cylinder-head-temperature correlation, as illustrated and subsequently described. When these factors are evaluated, the relation between H and the various operating conditions will be completely defined by equation (6) or (7) and these equations will then serve to correlate and permit the prediction of coolant heat rejections for any engine and coolant operating condition.

SIGNIFICANCE OF FACTORS

Coolant heat rejection H .—The total coolant heat rejection, including the heat rejected from both the cylinder heads and the cylinder barrels, is used in the heat-rejection correlation presented herein. This value of coolant heat rejection was determined from the measured flow and temperature rise of the coolant cooling water and was corrected for an estimated piping loss of 2 percent of the heat rejected.

Cylinder temperature T_h .—The temperature T_h used in the correlation of cylinder-head temperatures is the average of the temperatures measured between the exhaust valves for the 12 cylinders of the engine. This temperature location was chosen because it is the most widely used temperature for this engine and, being in the hottest region of the cylinder head, may be considered indicative of critical cooling conditions. Although an average cylinder-head temperature is indicated in the derivation of equations (4) and (5) and is used in the correlation presented in reference 1, a satisfactory correlation would be expected for any single temperature location. This possibility of satisfactorily correlating the temperature of any location is a result of the linear relation (reference 3) that exists between temperatures at various locations in the cylinder head.

In order to permit an evaluation of the maximum cylinder-head temperature obtained for any operating condition, the relation between the average temperature for the 12 cylinders and the temperature of the hottest cylinder is presented.

Effective cylinder-gas temperature T_g .—The effective cylinder-gas temperature T_g is the gas temperature effective in transferring heat from the cylinder gases to the cylinders, and, as previously indicated, is considered a function of the fuel-air ratio, inlet-manifold temperature, ignition timing, and exhaust pressure. The value of T_g for the various engine conditions for the correlation of both cylinder-head temperatures and coolant heat rejections is determined from tests subsequently described and illustrated.

Dry inlet-manifold temperature T_m .—The true inlet-manifold temperature in a conventional multicylinder engine is difficult to measure because of the presence of unevaporated fuel in the charge mixture. For cooling correlations, the expedient of using a calculated dry inlet-manifold temperature instead of the measured manifold temperature is adopted. This dry inlet-manifold temperature is defined as the sum of the air temperature at the carburetor inlet and the calculated temperature rise of the air incurred in passing through the supercharger. This temperature rise

was calculated on the assumption that there was no fuel vaporization. By assuming a value of 0.96 for the slip factor, which is the ratio of the pressure coefficient to the adiabatic efficiency of the supercharger, the dry inlet-manifold temperature T_m may be written as

$$T_m = T_c + \frac{0.96 U^2}{J g c_p} \quad (8)$$

For the single-stage engines used, this relation reduces to

$$T_m = T_c + 25.28 \left(\frac{N}{1000} \right)^2 \quad (9)$$

For the tests of the engine fitted with the aftercooler, the temperature drop of the charge mixture incurred in passing through the aftercooler was calculated from the heat rejected to the aftercooler coolant and subtracted from the manifold temperature determined from equation (9).

Charge flow W_c and fuel-air ratio.—The value of charge flow W_c was taken as the total charge flow (air plus fuel) to the engine, although similar correlations may also be made on the basis of the air flow alone. The fuel-air ratio used was the mean fuel-air ratio to all cylinders as obtained from the total air and fuel flows.

Coolant flow W_i and coolant temperature T_i .—The coolant flow W_i was, for simplicity, taken as the total coolant flow to both cylinder banks. Although the construction of the coolant passages in the engine is such that the flow varies considerably from cylinder to cylinder, it is shown in reference 3 that changes in the total flow effect proportional changes in the flow over any one cylinder. The coolant temperature T_i was taken as the average of the inlet and outlet temperatures of both cylinder banks.

Physical properties of coolants.—The physical properties of the coolants (specific heat c , absolute viscosity μ , thermal conductivity k , and therefore the Prandtl number Pr) were evaluated at the average coolant temperature T_i . The values used were obtained from reference 4 and are presented in convenient curve form in reference 1.

Constants B_1 , B_2 , and Z and exponents m , n , and s .—The constants B_1 , B_2 , and Z and the exponents m , n , and s are determined from the test results, and the details of the evaluation of these factors are given in the following section. The values obtained for these constants and exponents, and, in addition, the value of T_g , will not necessarily be the same for both the cylinder-head-temperature and the heat-rejection correlations because in the cylinder-head-temperature correlation only the cylinder head is involved; whereas in the heat-rejection correlation both the cylinder head and the cylinder barrel are involved in the transfer of heat to the coolant.

CYLINDER-HEAD-TEMPERATURE CORRELATION

EVALUATION OF FACTORS

As previously indicated, the value of the effective gas temperature T_g at various engine operating conditions and

the values of the constant Z and the exponents m , n , and s must be evaluated before the correlation equations may be used to determine the cylinder-head temperature T_h for various engine operating conditions. In general, the values of these factors are determined independently from analysis of test data that are selected to permit a simplification of correlation equation (4) as required for this evaluation. The details of the evaluation of these factors are described and illustrated in the following paragraphs.

Effective cylinder-gas temperature T_g .—The method used to evaluate T_g , which has been successfully applied to the correlation of cooling data obtained for a large number of air-cooled engines and the liquid-cooled engine of reference 1, constitutes first the establishment of a reference value of T_g for a given set of operating conditions and then the determination of the variation of T_g with each of the pertinent engine conditions. On the basis of previous correlation work, and in the interest of consistency with other cylinder-head-temperature correlations (references 1, 5, 6, and 7), a reference value of T_g for this correlation of 1150° F was chosen for a fuel-air ratio of 0.080, an inlet-manifold temperature of 80° F, standard ignition timing (approximately maximum power setting), and an exhaust pressure of 30 inches of mercury absolute. Investigation has shown that the correlation is insensitive to changes in the magnitude of this reference value of T_g ; it is important, however, that its variation with engine conditions be accurately determined.

The variation of T_g with fuel-air ratio, manifold temperature, ignition timing, and exhaust pressure was determined from the tests in which these factors were independently varied while holding all other engine and coolant conditions constant. For such conditions, correlation equation (4) reduces to

$$\frac{T_h - T_i}{T_g - T_h} = \text{constant} \quad (10)$$

This constant can be evaluated from the cylinder-head and coolant-temperature data obtained at the reference operating condition for which the value of T_g has already been chosen. The variation of T_g with each of the aforementioned variables can then be calculated from the values of the constant and the coolant and cylinder-head temperatures obtained for the range of operating conditions in question. Although the value of the constant is dependent on the charge flow and coolant conditions of the reference operating condition and thus was not the same for each series of runs for which the variation of T_g was being established (see table I), the variation of T_g from the chosen reference value is independent of the value of the constant and hence is valid for any engine charge flow and coolant operating condition.

The variation of T_g with fuel-air ratio is shown in figure 3. The values of T_g presented have been corrected to a dry inlet-manifold temperature of 80° F in accordance with a

relation between the manifold temperature and T_g that will be subsequently discussed. A maximum value of T_g is reached at a fuel-air ratio of about 0.067, which is approximately equal to the fuel-air ratio for the stoichiometric mixture. Data obtained from three different engines, one of which was fitted with an aftercooler, are included in figure 3 and close agreement among the three is noted. The variations obtained for both the single-cylinder engine of reference 1 and the air-cooled engine of reference 5 are also shown in this figure. The values of T_g for the single-cylinder engine are seen to be somewhat lower than those for the multicylinder engines of the present investigation, particularly in the rich region, but close agreement between the multicylinder liquid-cooled and air-cooled engines is evident.

The variation of T_g with the calculated dry inlet-manifold temperature T_m is shown in figure 4. The data, which are presented for three engines and various engine operating conditions, have been adjusted to a fuel-air ratio of 0.080 in accordance with the relation between T_g and the fuel-air ratio that is presented in figure 3. As indicated in equation (9), the inlet-manifold temperature may be varied by changing either the carburetor inlet-air temperature or the engine speed. Data obtained from tests wherein each of these quantities was independently varied are presented (fig. 4) and both sets of data fall on a common curve. An average

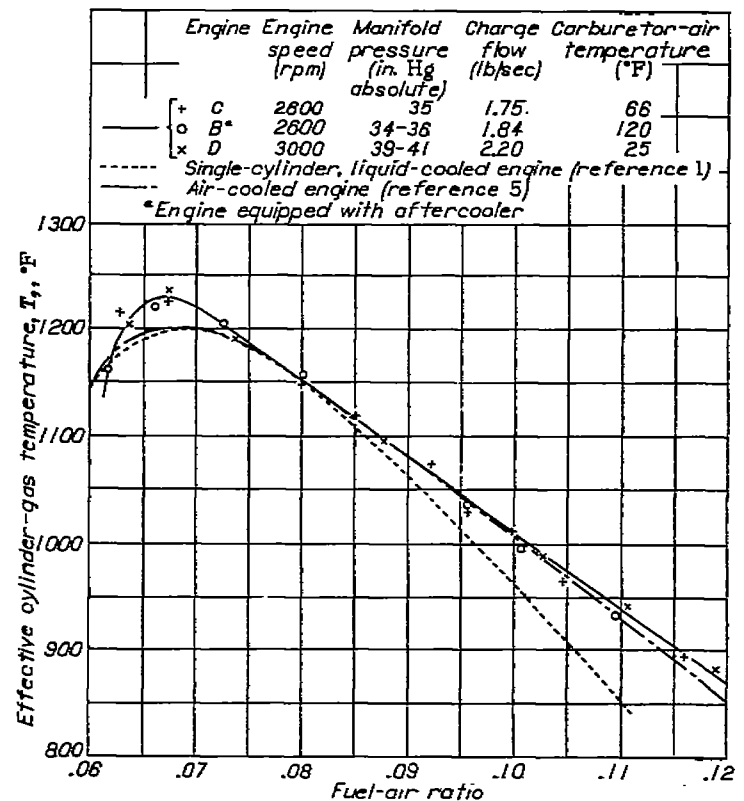

FIGURE 3.—Variation of effective cylinder-gas temperature with fuel-air ratio for cylinder-head-temperature correlation. Data corrected to dry inlet-manifold temperature of 80° F; exhaust pressure, 29-30 inches mercury absolute; standard ignition timing.

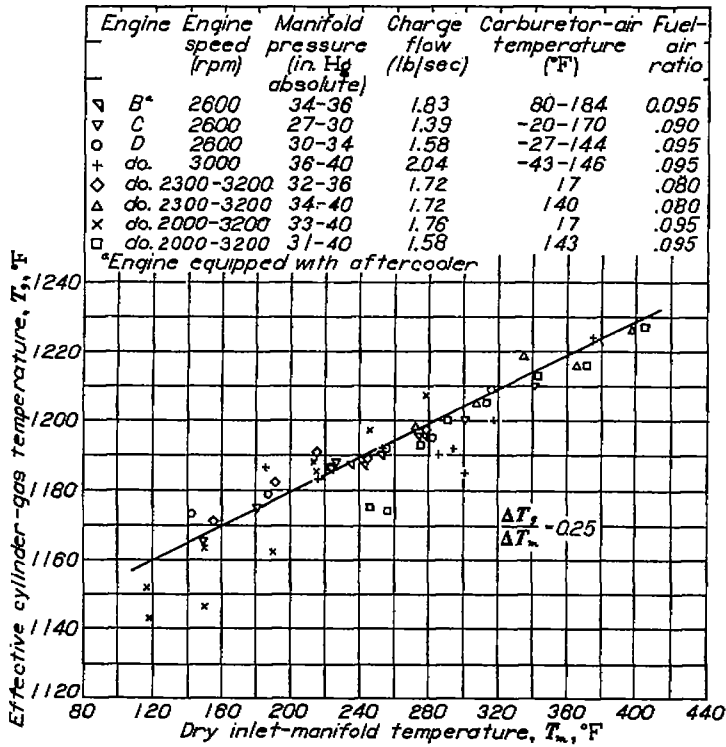

FIGURE 4.—Variation of effective cylinder-gas temperature with manifold temperature for cylinder-head-temperature correlation. Data corrected to fuel-air ratio of 0.080; exhaust pressure, 29-30 inches mercury absolute; standard ignition timing.

change in T_g of about 0.25°F per degree Fahrenheit change in T_m is indicated and correction of T_g to other than 80°F manifold temperature is therefore made in accordance with the relation

$$\Delta T_g = 0.25 (T_m - 80) \quad (11)$$

The effect of exhaust pressure on T_g for three values of fuel-air ratio and various engine conditions is presented in figure 5. These values of T_g have been corrected to an inlet-manifold temperature of 80°F by means of equation (11). An increase in exhaust pressure results in an increase in T_g , and, for the range of fuel-air ratios covered, the increase is somewhat greater at the lean than at the rich mixtures. A similar effect of exhaust pressure on T_g was obtained in the tests of an air-cooled engine, which are reported in reference 6, and also in tests of another liquid-cooled engine conducted at this laboratory (data unavailable). For convenience, a cross plot of these curves is shown in figure 6 in which T_g is plotted as a function of fuel-air ratio for exhaust pressures of 10, 20, 30, 40, and 50 inches of mercury absolute. The curve for an exhaust pressure of 30 inches

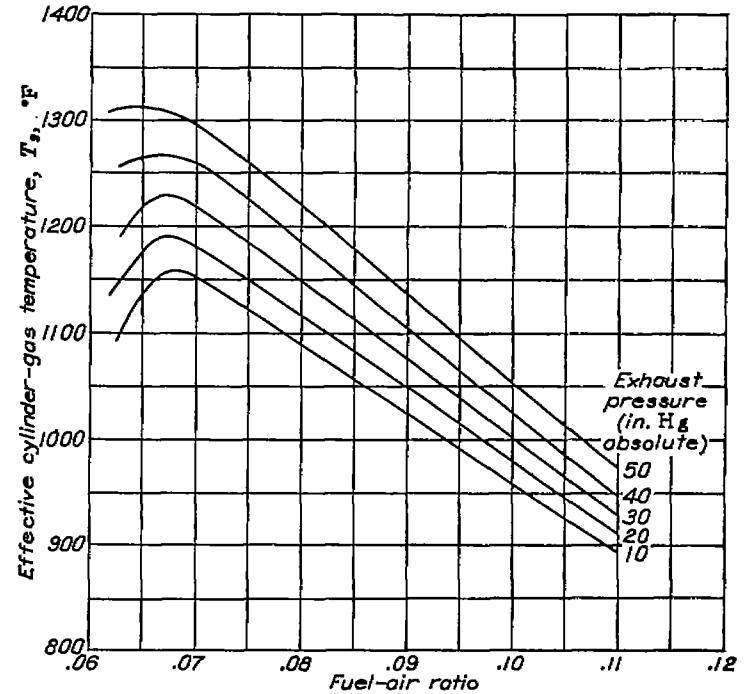

FIGURE 6.—Variation of effective cylinder-gas temperature with fuel-air ratio at various exhaust pressures for cylinder-head-temperature correlation (obtained from cross plot of fig. 5). Data corrected to dry inlet-manifold temperature of 80°F ; standard ignition timing; engine D.

of mercury was obtained from figure 3 and the shape of this curve was used as a guide in drawing those for the other exhaust pressures.

The variation of T_g with ignition timing for engine speeds of 2600 and 3000 rpm is presented in figure 7 as a plot of ΔT_g against ignition timing. This variable ΔT_g represents the change in effective cylinder-gas temperature from the value at the standard ignition timing (exhaust spark plugs) of 34°B.T.C . The magnitude of the correction to T_g for other than standard ignition timing increases positively as

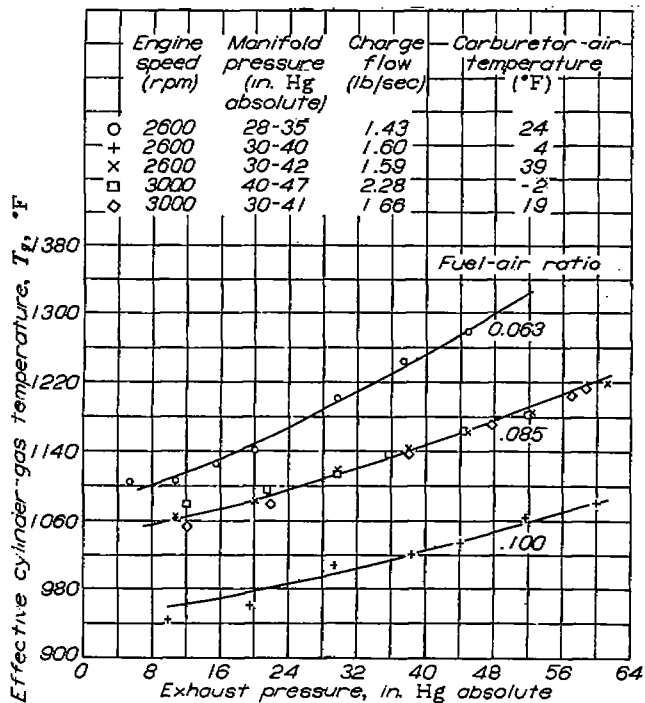

FIGURE 5.—Variation of effective cylinder-gas temperature with exhaust pressure at several fuel-air ratios for cylinder-head-temperature correlation. Data corrected to dry inlet-manifold temperature of 80°F ; standard ignition timing; engine D.

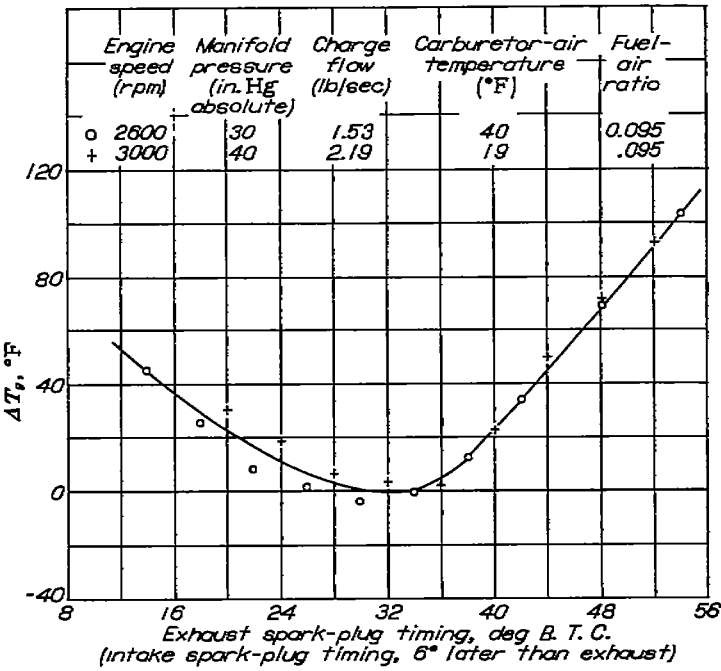

FIGURE 7.—Variation of change in effective cylinder-gas temperature with ignition timing for cylinder-head-temperature correlation. Engine D.

the spark setting is increased or decreased from the normal position. The data separate somewhat with engine speed for a spark-plug timing later than the normal setting but, for simplicity, a single curve has been drawn through all the data.

Exponent n on charge flow.—The value of the exponent n on charge flow W_c was obtained from tests at constant coolant conditions in which the charge flow was varied by changing the engine speed, manifold pressure, or exhaust pressure. For such conditions, equation (4) reduces to

$$\frac{T_h - T_i}{T_e - T_h} = B_4 W_c^n \quad (12)$$

A logarithmic plot of $\frac{T_h - T_i}{T_e - T_h}$ against W_c is shown in figure 8 and the slope of the line through the data, which is equal to the value of the exponent n , is 0.60. Although the absolute value of the factor $\frac{T_h - T_i}{T_e - T_h}$ would be different for different coolant conditions, the slopes of the resulting lines would be the same. The data for the runs with a coolant flow of 300 gallons per minute were adjusted to a flow of 250 gallons per minute to be consistent with the rest

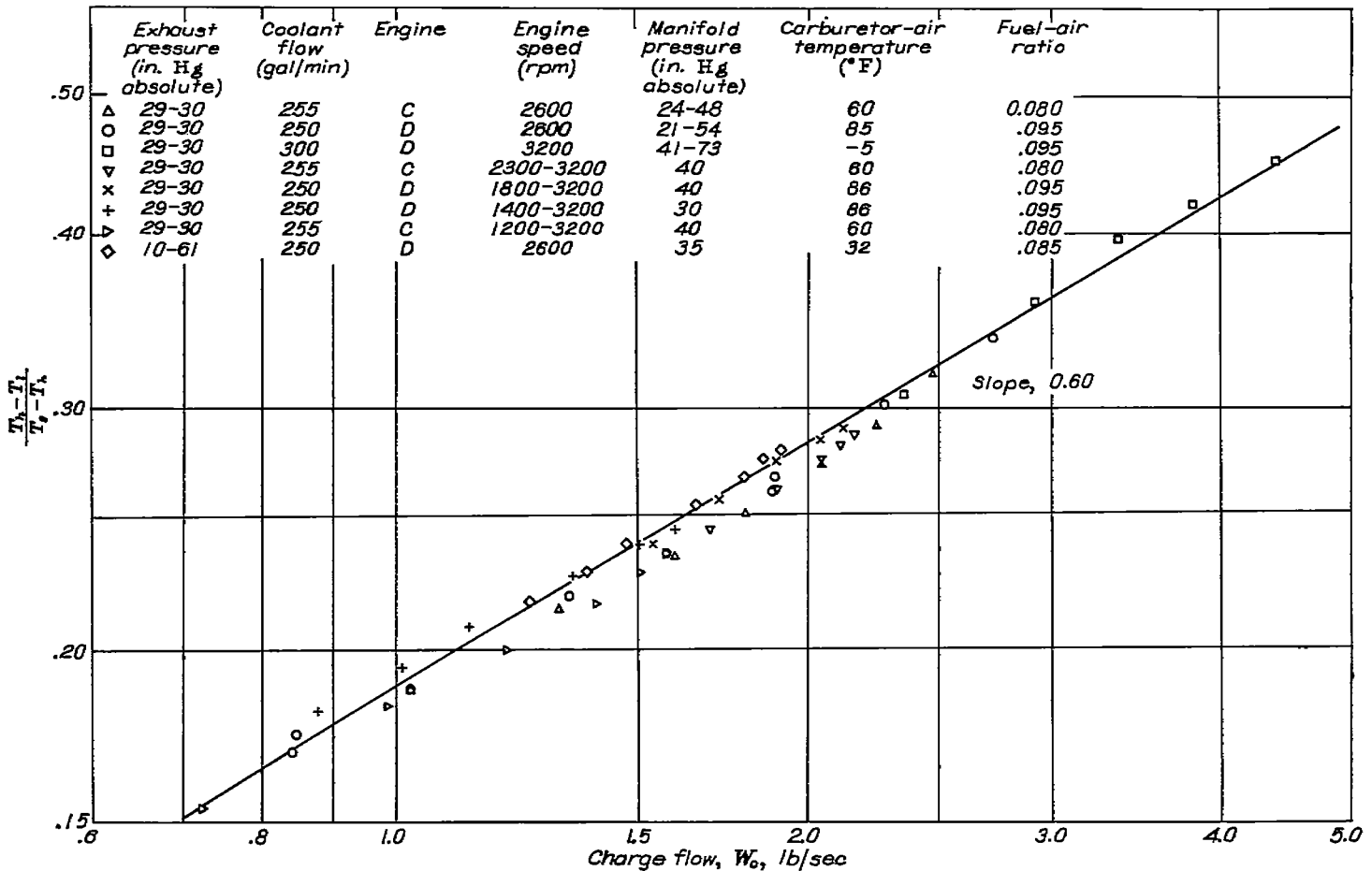

FIGURE 8.—Determination of exponent n on charge flow W_c for cylinder-head-temperature correlation from variation of $\frac{T_h - T_i}{T_e - T_h}$ with W_c . Coolant, 30-70 ethylene glycol-water; average coolant temperature, 245° F.

of the data by changing the factor $\frac{T_h - T_i}{T_g - T_h}$ in accordance with the effect of coolant flow on the cylinder-head temperature presented in reference 3. Data covering a wide range of engine speed, manifold pressure, and exhaust pressure are presented for two engines and close agreement is noted.

Factor Z.—The factor Z was determined from tests in which the coolant temperature and composition were held constant while the coolant flow W_c was varied. For these conditions, equation (4) may be written

$$\left(\frac{T_h - T_i}{T_g - T_h}\right) \left(\frac{1}{W_c^{0.60}}\right) - Z = B_5 \left(\frac{1}{W_i}\right)^m \quad (13)$$

A plot of $\left(\frac{T_h - T_i}{T_g - T_h}\right) \left(\frac{1}{W_c^{0.60}}\right)$ against $1/W_i$, using the previously determined values of T_g and the exponent n , is shown in figure 9 for five different coolant compositions. Extrapolation of these data to $1/W_i = 0$ (at which point the value of $\left(\frac{T_h - T_i}{T_g - T_h}\right) \left(\frac{1}{W_c^{0.60}}\right)$ is equal to the Z factor) results in a value of 0.13 for Z . Because of the somewhat arbitrary nature of this extrapolation, the final value for Z was chosen by drawing curves having the same general shape as those presented for a similar plot in reference 1 and then completing and plotting a final correlation of all the data (based on equation (4)) using three different values for Z in the neighborhood of the value indicated by the curves; the value that gave the most satisfactory correlation (0.13) was finally chosen.

In the investigation of reference 3, it was found that the cylinder-head temperature, particularly in the exhaust or hot side of the head, increased with engine running time during the initial operation of the engine. This increase in temperature is illustrated in figure 10 and it is noted that the temperature between the exhaust valves increased about 25° F during approximately the initial 100 hours of engine running time and remained substantially constant as the operating time was further increased. Unlike the variation exhibited by this temperature location, the temperature at

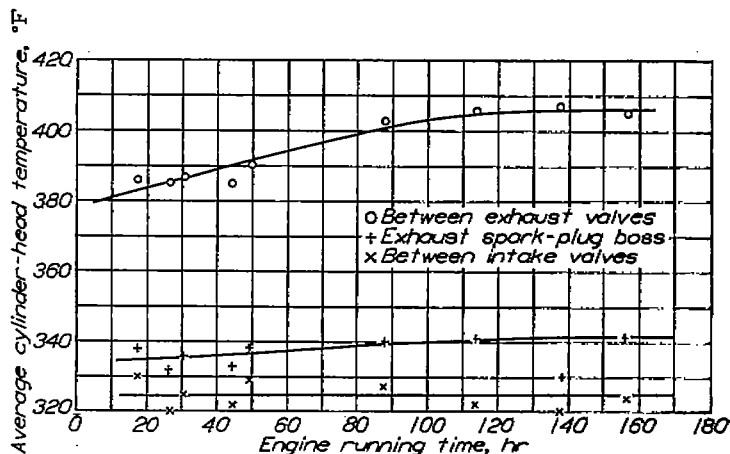

FIGURE 10.—Variation of average cylinder-head temperatures with engine running time. Engine speed, 2800 rpm; manifold pressure, 32 inches mercury absolute; charge flow, 1.57 pounds per second; fuel-air ratio, 0.095; carburetor-air temperature, 82° F; coolant, 30-70 ethylene glycol-water; coolant flow, 300 gallons per minute; average coolant temperature, 245° F; standard ignition timing; exhaust pressure, 29-30 inches mercury absolute; engine D.

the exhaust spark-plug boss increased only slightly and the temperature between the intake valves remained constant over the entire period of the investigation. As discussed in reference 3, an inspection of the coolant passages of a scrapped cylinder head revealed scale deposits on the exhaust side of the cylinder head but none on the intake side. This increase in temperature was therefore attributed to the scale deposits on the coolant passages. Because the Z factor accounts for the temperature drop through the cylinder head, this increase in cylinder-head temperature with engine running time will be reflected as a similar variation in the Z factor. The value of the Z factor (0.13), which was determined after about 100 hours accumulated engine running time, is therefore applicable only for this or greater engine running times. Although the final correlation is insensitive to the magnitude of this basic value of Z , it is necessary that the variation of Z , which occurs during the initial period of engine running time, be accurately determined and included in the final correlation.

The variation of Z during the initial period of engine running time was determined from cylinder-head-temperature data obtained at a reference operating condition. For this reference condition, the coolant conditions were constant; accordingly, equation (13) may be written

$$\left(\frac{T_h - T_i}{T_g - T_h}\right) \left(\frac{1}{W_c^{0.60}}\right) - Z = \text{constant} \quad (14)$$

The value of the constant is determined from the substitution into the equation of the previously determined value of Z and the pertinent engine and coolant data obtained at 100 hours engine running time. The value of Z at other engine running times is then determined from the value of the constant and the cylinder-head temperatures obtained at the running time under consideration.

A plot showing the variation of the Z factor for engine D with engine running time is presented in figure 11. It can be seen that the Z factor increases during the initial engine operating time in a manner similar to that for the cylinder-head temperature (fig. 10) and that there is no significant change in the value of Z after about 100 hours running time. It is expected that this phenomenon will vary from engine to engine depending upon the history of operation. The range

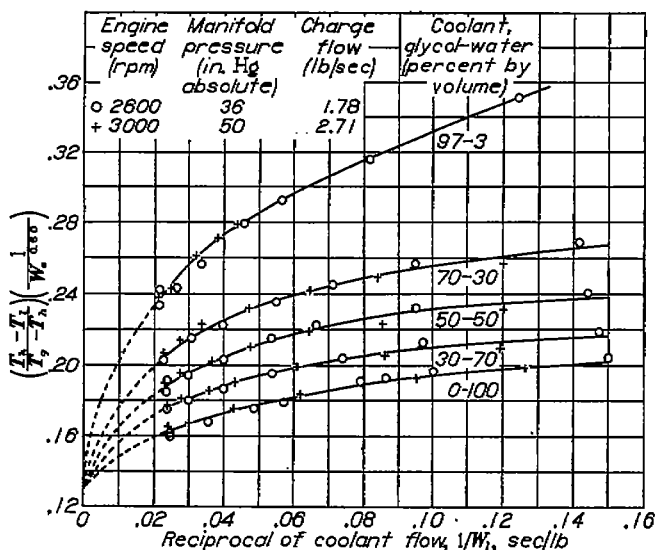

FIGURE 9.—Determination of factor Z from variation of $\left(\frac{T_h - T_i}{T_g - T_h}\right) \left(\frac{1}{W_c^{0.60}}\right)$ with $1/W_i$ for cylinder-head-temperature correlation. Average coolant temperature, 245° F; engine D.

of conditions and engine running time over which this variation was established is indicated in table I.

For engine D, the value of Z used in the subsequent cylinder-head-temperature correlation plots was determined from the curve of figure 11. For engines A, B, and C, the data were insufficient to provide separate evaluation of Z , but most of the correlation data provided by these engines were obtained after the engines had been run for a considerable length of time so a value of 0.13 was used. Because this value resulted in satisfactory correlation of the cylinder-head-temperature data from engines A, B, and C with those of engine D, it may be assumed that the coolant passages of these engines were in about the same condition as those of engine D after about 100 hours engine running time.

Exponent m on coolant-flow parameter W_i/μ .—The value of the exponent m on the coolant-flow parameter W_i/μ was determined from tests in which the coolant temperature and

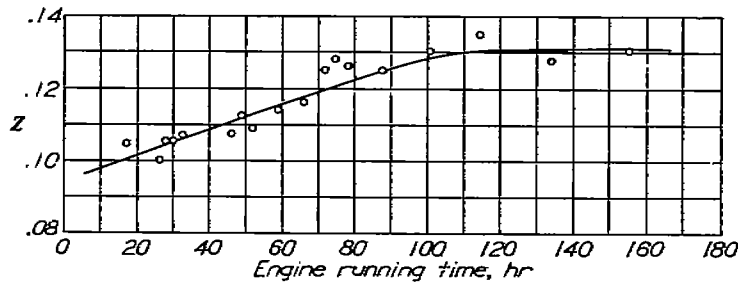

FIGURE 11.—Variation of factor Z for cylinder-head-temperature correlation with initial engine running time attributed to scale build-up in coolant passages of engine D.

composition were held constant while the coolant flow W_i was varied (similar to data for determination of Z factor). For these conditions, equation (4) may be written

$$\left[\left(\frac{T_h - T_i}{T_s - T_h} \right) \left(\frac{1}{W_c^{0.60}} \right) - Z \right] k = B_6 \left(\frac{W_i}{\mu} \right)^{-m} \quad (15)$$

A logarithmic plot of the factor $\left[\left(\frac{T_h - T_i}{T_s - T_h} \right) \left(\frac{1}{W_c^{0.60}} \right) - Z \right] k$ against W_i/μ is shown in figure 12 for five different coolant compositions. The slope of the straight lines through these data is equal to the exponent on W_i/μ . Lines having the same slope are drawn through the data for each coolant and the value of the exponent m is accordingly established as 0.48. This value for the exponent m , which is established from these selected data, will, of course, be verified by the slope of the line through all the data on the final correlation plot based on equation (4).

Exponent s on Prandtl number Pr .—The value of the exponent s on the Prandtl number Pr was determined from data for a constant value of W_i/μ ; for this condition, equation (4) may be reduced to

$$\left[\left(\frac{T_h - T_i}{T_s - T_h} \right) \left(\frac{1}{W_c^{0.60}} \right) - Z \right] k = B_7 (Pr)^{-s} \quad (16)$$

The slope of the line determined by a logarithmic plot of $\left[\left(\frac{T_h - T_i}{T_s - T_h} \right) \left(\frac{1}{W_c^{0.60}} \right) - Z \right] k$ against Pr would then establish the value of the exponent s . A wide range of Prandtl number for this plot may be obtained if data for several different

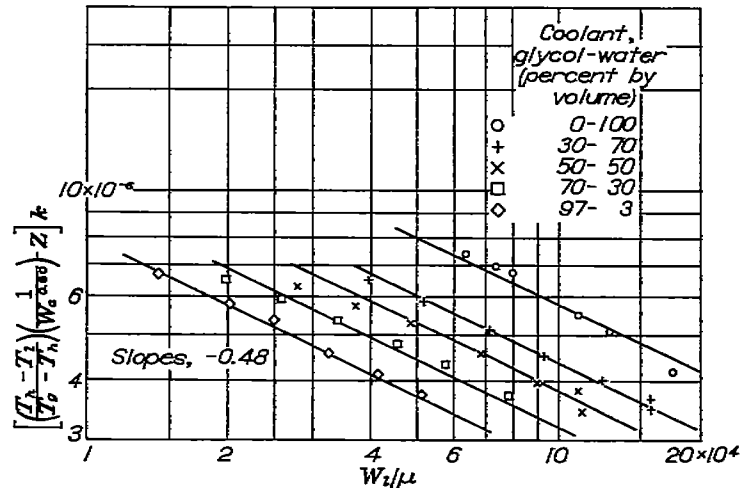

FIGURE 12.—Determination of exponent m on coolant-flow parameter W_i/μ for cylinder-head-temperature correlation from variation of $\left[\left(\frac{T_h - T_i}{T_s - T_h} \right) \left(\frac{1}{W_c^{0.60}} \right) - Z \right] k$ with W_i/μ for various coolants. Average coolant temperature, 245° F; engine D.

coolants are used. In order to construct this plot, it is convenient to obtain values of the factor

$$\left[\left(\frac{T_h - T_i}{T_s - T_h} \right) \left(\frac{1}{W_c^{0.60}} \right) - Z \right] k$$

from figure 12 for a constant value of W_i/μ and then to cross-plot the values of this factor against the Prandtl number Pr of the different coolants. Data obtained from a cross plot of figure 12 at a constant value of W_i/μ equal to 55,000 is shown in figure 13 and the slope of this line thus establishes the value of the exponent s on the Prandtl number Pr as 0.33.

FINAL CORRELATION

Final correlation with coolant-flow factor W_i/μ as independent variable.—The final correlation based on equation (4), which is obtained by plotting the factor

$$\left[\left(\frac{T_h - T_i}{T_s - T_h} \right) \left(\frac{1}{W_c^{0.60}} \right) - Z \right] k (Pr)^{0.33}$$

against W_i/μ on logarithmic coordinates for all test data for the four engines, is presented in figure 14(a). Although the data points scatter considerably, the maximum variation

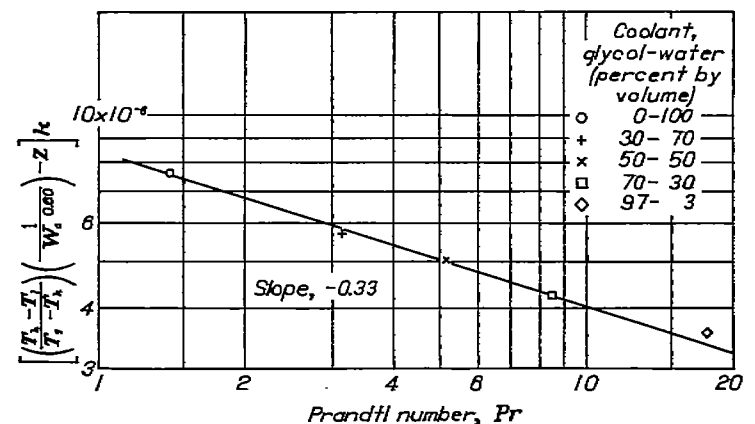
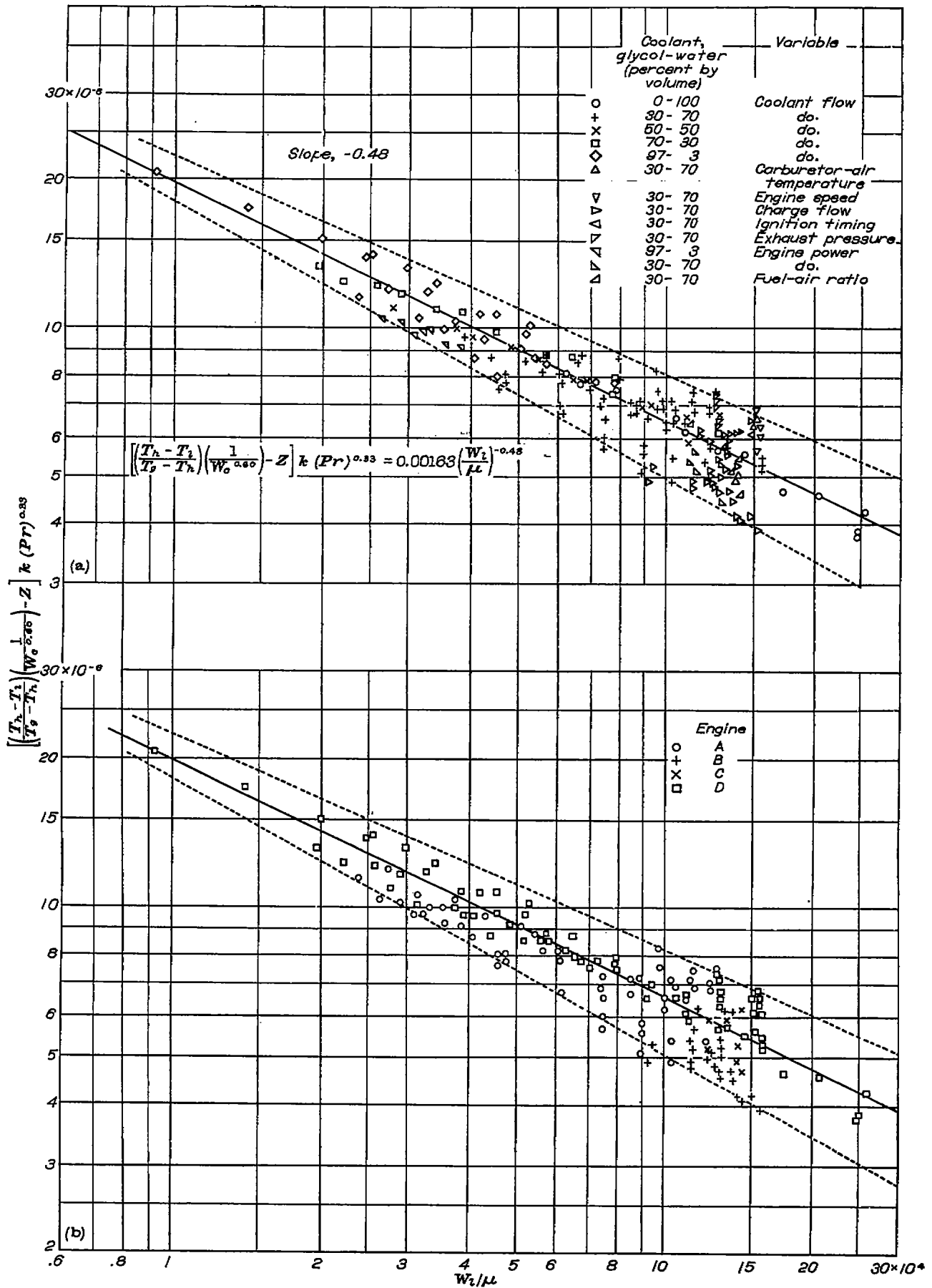

FIGURE 13.—Determination of exponent s on Prandtl number Pr for cylinder-head-temperature correlation from variation of $\left[\left(\frac{T_h - T_i}{T_s - T_h} \right) \left(\frac{1}{W_c^{0.60}} \right) - Z \right] k$ with Pr as obtained from cross plot of figure 12 at value for W_i/μ of 55,000. Average coolant temperature, 245° F; engine D.



(a) Data keyed for different variables.

(b) Data keyed for different engines.

FIGURE 14.—Final correlation of cylinder-head temperatures based on equation (4).

in T_h resulting from this scatter is not large. A variation in T_h of $\pm 12^\circ\text{F}$ for typical engine conditions at normal rated power is represented by the dashed lines in the figure, and it is seen that almost all the data lie within this band.

The value of the exponent m , which is obtained from the slope of the line through the data, is, as previously determined, equal to 0.48 and the value of the constant B_3 , found by substitution of the values of the coordinate of any point on the line into the correlation equation, is equal to 0.00163. The final equation is accordingly written

$$\left[\left(\frac{T_h - T_i}{T_c - T_h} \right) \left(\frac{1}{W_c^{0.60}} \right) - Z \right] k (Pr)^{0.33} = 0.00163 \left(\frac{W_i}{\mu} \right)^{-0.48} \quad (17)$$

and will apply over a considerable range of engine operating conditions, coolant temperatures, coolant flows, and coolant compositions.

In order to illustrate the variation in the correlation obtained among the four engines, the correlation of figure 14 (a) is replotted in figure 14(b), using a different symbol for each engine. The separation of the data between engines is slight and the scatter for one engine is almost as great as the total scatter for all engines.

Final correlation with charge flow W_c as independent variable.—Correlation of the test data based on equation (5),

$$\text{wherein the factor } \left(\frac{T_c - T_h}{T_h - T_i} \right) \left[\left(\frac{0.00163}{W_i^{0.48}} \right) \left(\frac{\mu^{0.48}}{k(Pr)^{0.33}} \right) + Z \right]$$

is evaluated by using the previously determined values of m , s , Z , and B_3 and plotted against the charge flow W_c , is shown in figure 15. A straight line with a slope of -0.60 , which is equal in absolute value to the value of the exponent n on W_c , previously determined, is drawn through the

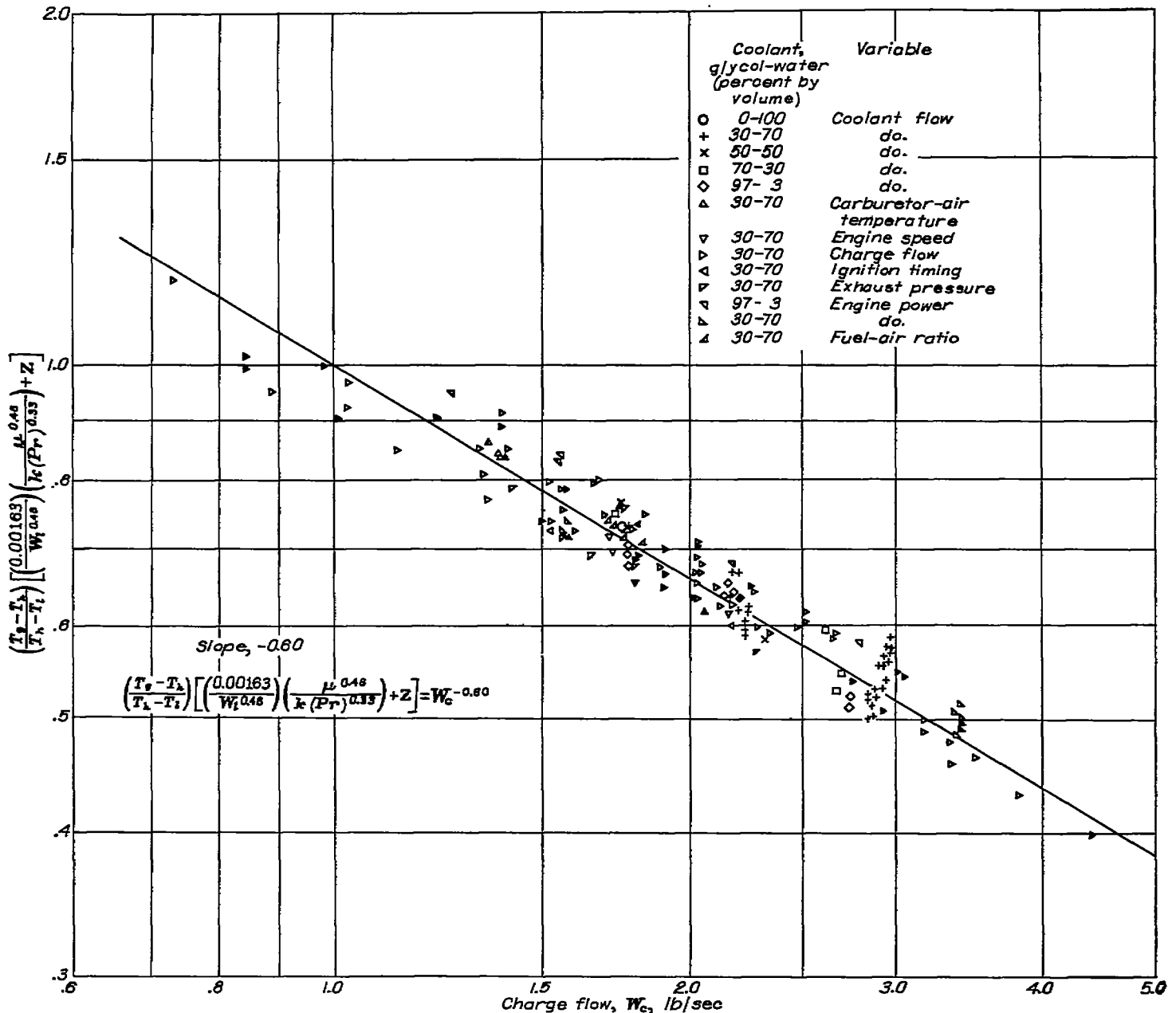

FIGURE 15.—Final correlation of cylinder-head temperatures based on equation (5).

data. As a result of the different arrangement of the terms in this equation, the scatter of the data is considerably less in figure 15 than in figure 14; the over-all accuracy of the correlation is, of course, the same.

When equation (17) is rearranged in accordance with this plot, the following form is obtained:

$$\left(\frac{T_c - T_h}{T_h - T_i}\right) \left[\left(\frac{0.00163}{W_i^{0.48}}\right) \left(\frac{\mu^{0.48}}{k(P_r)^{0.33}}\right) + Z \right] = W_c^{-0.60} \quad (18)$$

As previously mentioned, the values of the factor Z for engine D used in plotting the final correlation of figures 14 and 15 were obtained from figure 11. If a constant average value were used for Z, the scatter of the data would be increased from approximately $\pm 12^\circ$ to about $\pm 22^\circ$ F, depending upon the engine running time.

In order to facilitate the computation of head temperatures by means of equation (18), values of the coolant-property parameter $\left(\frac{\mu^{0.48}}{k(P_r)^{0.33}}\right)$ are presented in figure 16 for various coolant mixtures of ethylene glycol and water over a range of coolant temperatures.

Effect of boiling of coolant on correlation.—It was found in the investigation of reference 3 that under some conditions of operation a reduction in coolant flow increased the amount of boiling of the coolant thus reducing the normal tendency of the cylinder-head temperature to increase with reduced coolant flow. In order to determine the effect of this boiling of the coolant on the head-temperature correlation, the rela-

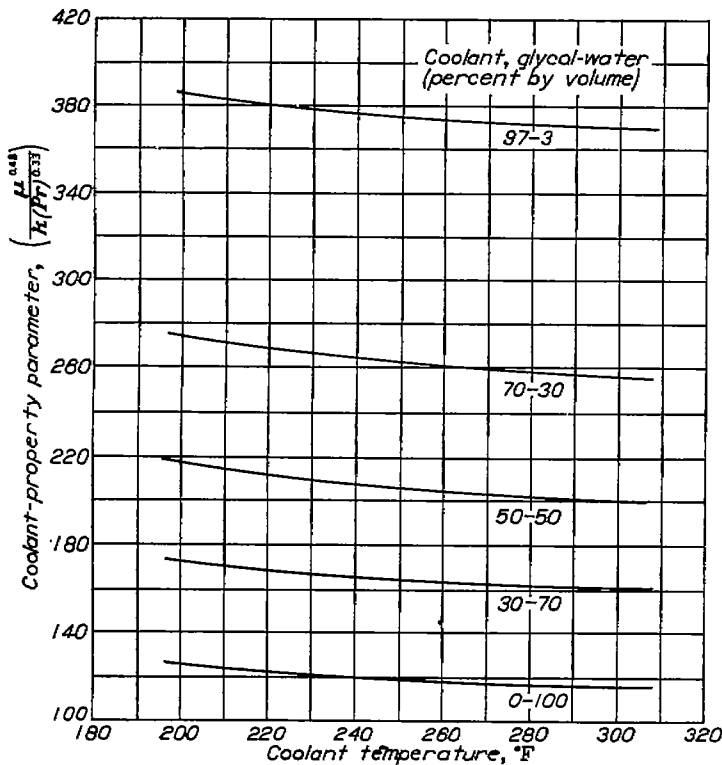

FIGURE 16.—Variation of coolant-property parameter $\left(\frac{\mu^{0.48}}{k(P_r)^{0.33}}\right)$ with coolant temperature for cylinder-head-temperature correlation.

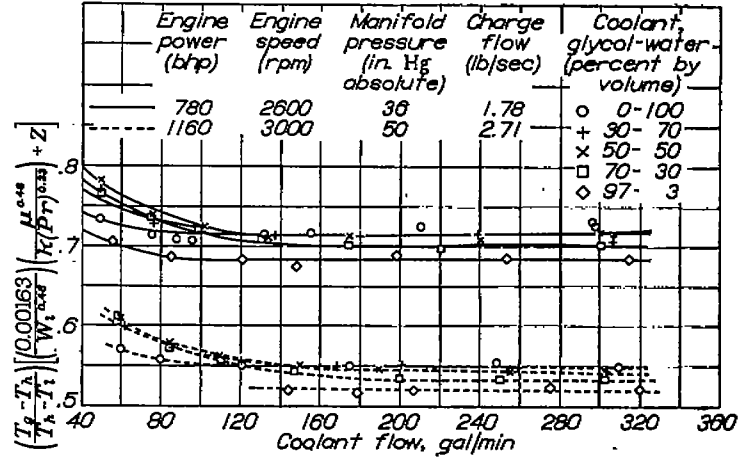

FIGURE 17.—Variation of $\left(\frac{T_c - T_h}{T_h - T_i}\right) \left[\left(\frac{0.00163}{W_i^{0.48}}\right) \left(\frac{\mu^{0.48}}{k(P_r)^{0.33}}\right) + Z \right]$ with coolant flow as indication of boiling. Average coolant temperature, 243° F; engine D.

tions given by equation (18) were considered. The left-hand side of this equation should normally be a function of only charge flow and, if boiling of the coolant were negligible, would be independent of the coolant flow. If, however, boiling occurs to an appreciable extent, the value of the left-hand side of this equation would be expected to vary with the coolant flow. A plot of this parameter against coolant flow is shown in figure 17 for two different engine operating conditions and several coolant compositions. For coolant flows greater than about 100 gallons per minute, the value of the plotted parameter is independent of the coolant flow, which indicates that boiling of the coolant did not occur to a noticeable degree in this range. For coolant flows less than about 100 gallons per minute, however, the value of the parameter increases with reduced coolant flow (depending on the engine power and coolant), which illustrates the tendency of boiling of the coolant in this range of flow rates to reduce the cylinder-head temperature.

The maximum variation of the parameter plotted in figure 17 is equivalent to a decrease in head temperature of less than 10° F. Because this variation is within the normal scatter of the data, the correlation is not seriously affected by boiling for the ranges of variables covered. Extrapolation of this correlation to combinations of higher engine power, lower coolant flows, or lower coolant pressures than those covered by this investigation would, however, be subject to uncertainties and reduced accuracy of prediction of cylinder temperatures.

Relation between maximum and average cylinder-head temperature.—In figure 18, the cylinder-head temperature between the exhaust valves of the hottest cylinder is plotted against the average temperature of the 12 cylinders at this location. Good correlation of these data is obtained for all conditions and for all engines with the maximum cylinder-head temperature ranging from 10° to 20° F higher than the average temperature. From the correlation of the average cylinder-head temperature with the primary engine variables and coolant variables given in figure 14 or 15 and from the

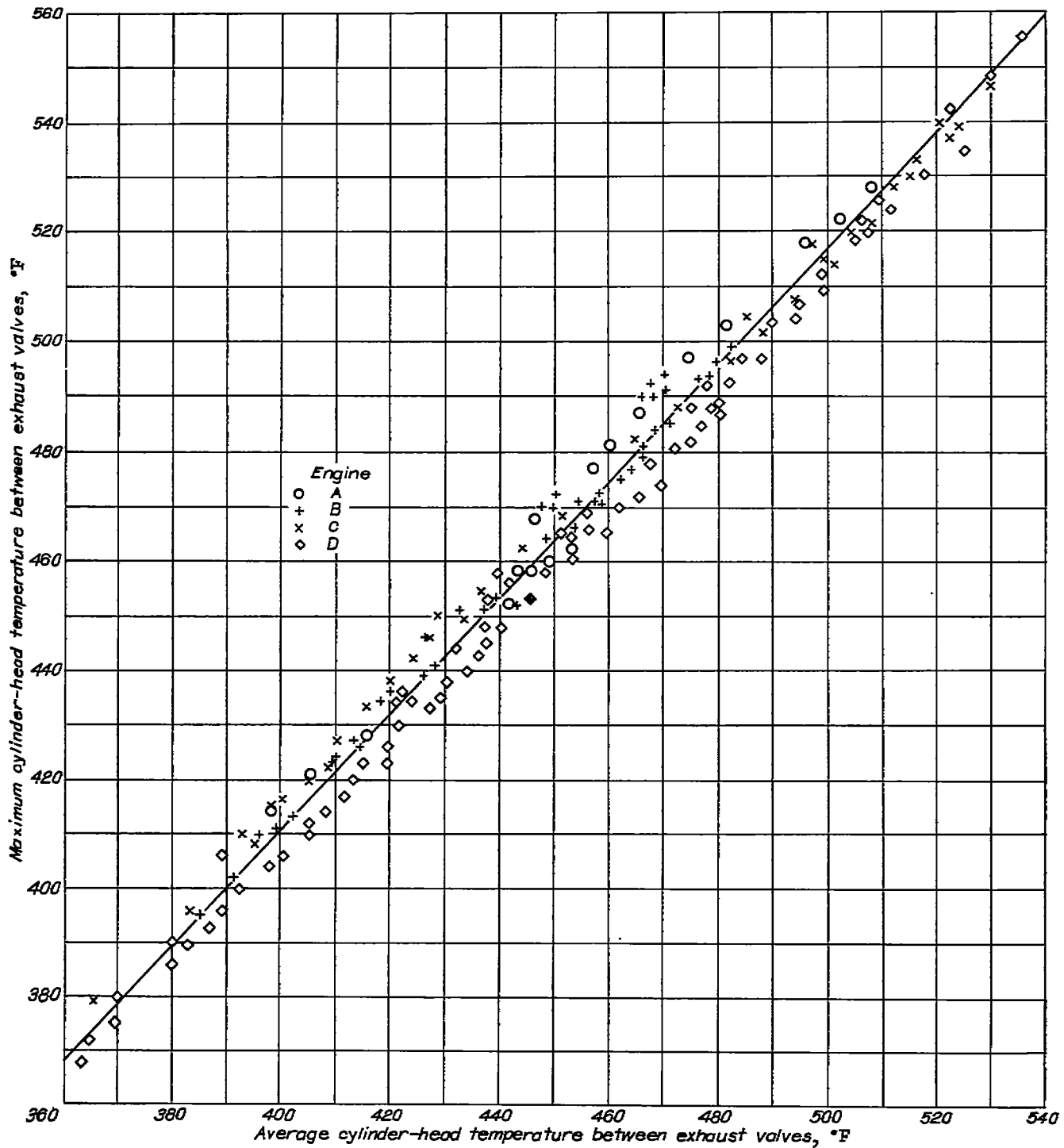

FIGURE 18.—Relation of average cylinder-head temperature between exhaust valves for 12 cylinders to hottest cylinder temperature measured at same location.

relation between the maximum and average head temperatures shown in figure 18, an estimation of the maximum cylinder-head temperature between exhaust valves is possible for a large range of engine and coolant conditions.

COOLANT-HEAT-REJECTION CORRELATION

EVALUATION OF FACTORS

As previously discussed, the values of the various constants and exponents appearing in the correlation equations may

not necessarily be the same for both the cylinder-head-temperature correlation and the coolant-heat-rejection correlation because only the heat-transfer processes occurring in part of the cylinder head are involved in the cylinder-head-temperature correlation, whereas the heat-transfer processes occurring in the complete engine cylinder are involved in the heat-rejection correlation. The method of evaluating the various constants and exponents for the coolant-heat-rejection correlation is, however, similar to that

previously discussed for the cylinder-head-temperature correlation and the details of their determination are given in the following paragraphs.

Effective cylinder-gas temperature T_g .—Because of differences in the heat-transfer processes affecting the cylinder-head temperatures and the coolant heat rejections just discussed, the reference value of T_g of 1150° F that was used for the cylinder-head-temperature correlation was considered unsuitable for application to a correlation of coolant-heat-rejection data. Accordingly, a reference value of T_g for the coolant-heat-rejection correlation was determined from consideration of equation (1)

$$H = B_1 W_c^n (T_g - T_h) \quad (1)$$

The relation between H and T_h for constant W_c and T_g is obtained from runs in which one of the coolant variables is varied while all the engine conditions are held constant. These values of H are then plotted against T_h and extrapolated to zero H ; the value of T_h at zero H will then be equal to the value of T_g at the particular engine operating condition.

The value of T_h indicated in equation (1) should be an average inside wall temperature for the entire cylinder, but inasmuch as the instrumentation was insufficient to provide an average wall temperature, the average of the temperatures measured between the exhaust valves of the 12 cylinders was used. Although the resulting reference value for T_g is somewhat higher than what would have been obtained if an average cylinder temperature were used, this procedure is considered satisfactory; as previously mentioned for the cylinder-temperature correlation, the accuracy of the final correlation depends primarily on the accurate determination of the variation of T_g with the various engine operating conditions and is insensitive to fairly large changes in its reference value.

The resulting plot of H against T_h obtained from runs in which the coolant temperature T_i was varied for two different coolants is shown in figure 19. Extrapolation of the curves to zero H , at which point the average head temperature is equal to the effective gas temperature, gives an initial value for T_g of about 750° F for a fuel-air ratio of 0.095, a dry inlet-manifold temperature of 254° F, an exhaust pressure of 29 to 30 inches of mercury absolute, and standard ignition timing. When this initial value of T_g is corrected to the customarily assumed reference conditions of fuel-air ratio of 0.080, dry inlet-manifold temperature of 80° F, exhaust pressure of 29 to 30 inches of mercury absolute, and standard ignition timing in accordance with the relations to be presented later, a value of 760° F is obtained. Although this reference value of T_g for the coolant-heat-rejection correlation is considerably lower than the value of 1150° F used in the cylinder-head-temperature correla-

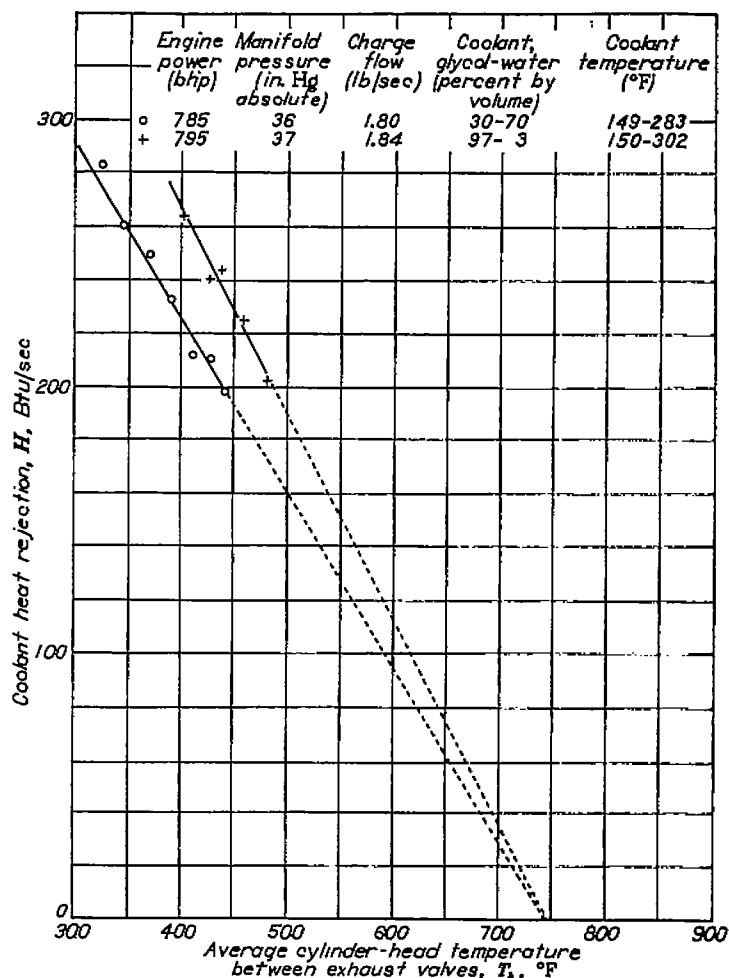

FIGURE 19.—Determination of T_g from variation of coolant heat rejection with average cylinder-head temperature between exhaust valves for coolant-heat-rejection correlation. Coolant flow, 200 gallons per minute; engine speed, 2600 rpm; fuel-air ratio, 0.095; dry inlet-manifold temperature, 254° F; exhaust pressure, 29-30 inches mercury absolute; standard ignition timing.

tions and approaches the value of 600° F used in cylinder-barrel-temperature correlations (references 1 and 7), it is considered suitable for the present correlation of coolant heat rejections in view of the satisfactory final correlation obtained.

The variation of T_g with fuel-air ratio, inlet-manifold temperature, ignition timing, and exhaust pressure for the heat-rejection correlation is determined in a manner similar to that for the head-temperature correlation from the tests in which these factors were each independently varied while holding all other conditions constant. For these conditions correlation equation (6) becomes

$$\frac{T_g - T_i}{H} = \text{constant} \quad (19)$$

This constant is evaluated from the heat-rejection and coolant-temperature data at the operating conditions for

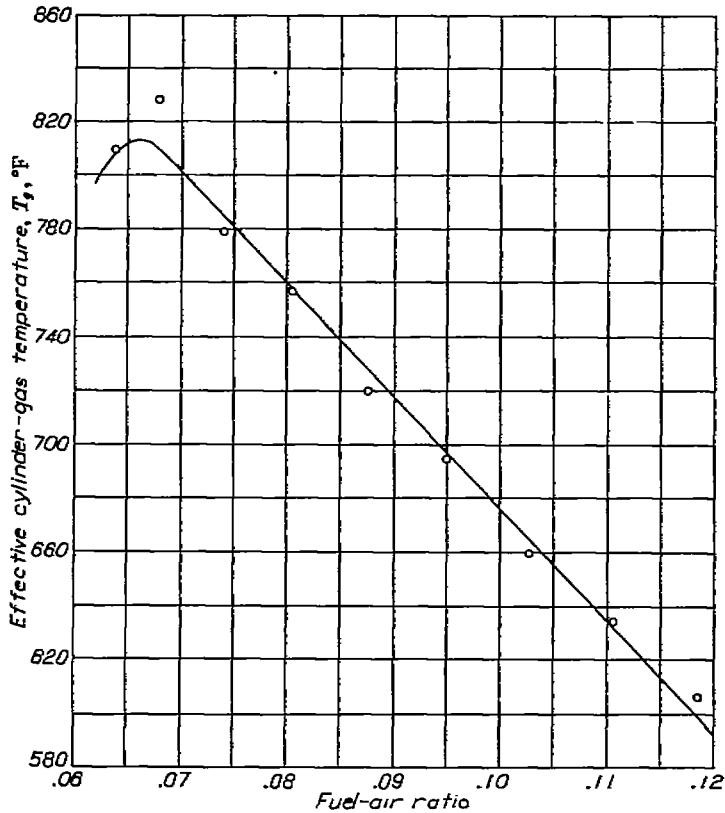

FIGURE 20.—Variation of effective cylinder-gas temperature with fuel-air ratio for coolant-heat-rejection correlation. Data corrected to dry inlet-manifold temperature of 80° F; exhaust pressure, 29-30 inches mercury absolute; standard ignition timing.

which the value of T_g has already been established. The variation in T_g with each of the aforementioned variables is then calculated from the value of the constant and the heat-rejection and coolant-temperature data obtained at the operating condition in question.

The variation of T_g with fuel-air ratio is shown in figure 20. The data have been corrected to a dry inlet-manifold temperature of 80° F in accordance with the relation between T_g and T_m to be presented later. Although the data points do not clearly define a curve in the region of stoichiometric fuel-air ratio, the shape of the curve in this region was made similar to that determined for similar relations in the cylinder-head-temperature correlations.

The variation of T_g with the calculated dry inlet-manifold temperature T_m is presented in figure 21. These data, which include both variable carburetor-air-temperature and variable engine-speed runs, have been corrected to a fuel-air ratio of 0.080 in accordance with the relation between T_g and fuel-air ratio presented in figure 20. Although there is considerable scatter of the data, the trends indicated by both types of run are the same. A line through the average of the data indicates an increase in T_g of about 0.30° F per degree Fahrenheit increase in T_m ; correction of T_g to other than 80° F inlet-manifold temperature is therefore made according to the following relation:

$$\Delta T_g = 0.30(T_m - 80) \tag{20}$$

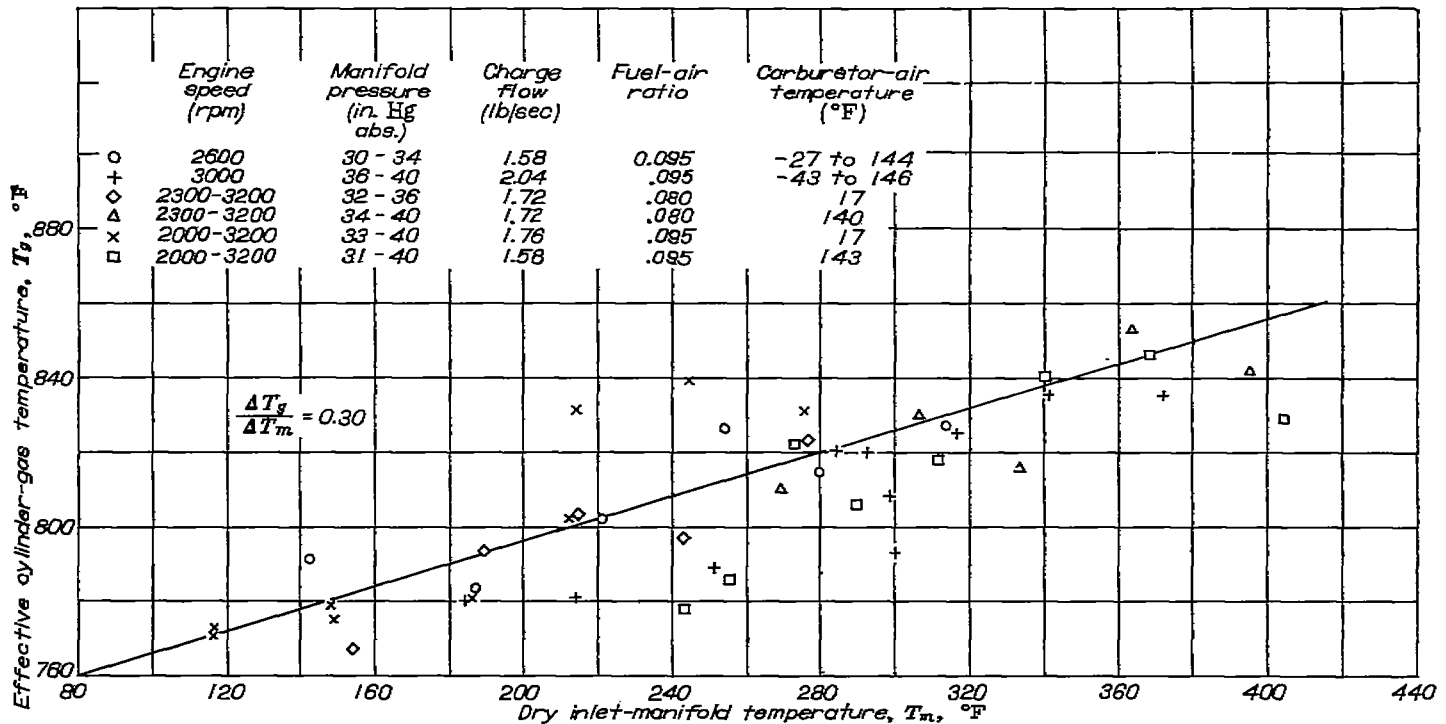

FIGURE 21.—Variation of effective cylinder-gas temperature with inlet-manifold temperature for coolant-heat-rejection correlation. All data corrected to fuel-air ratio of 0.080; exhaust pressure, 29-30 inches mercury absolute; standard ignition timing.

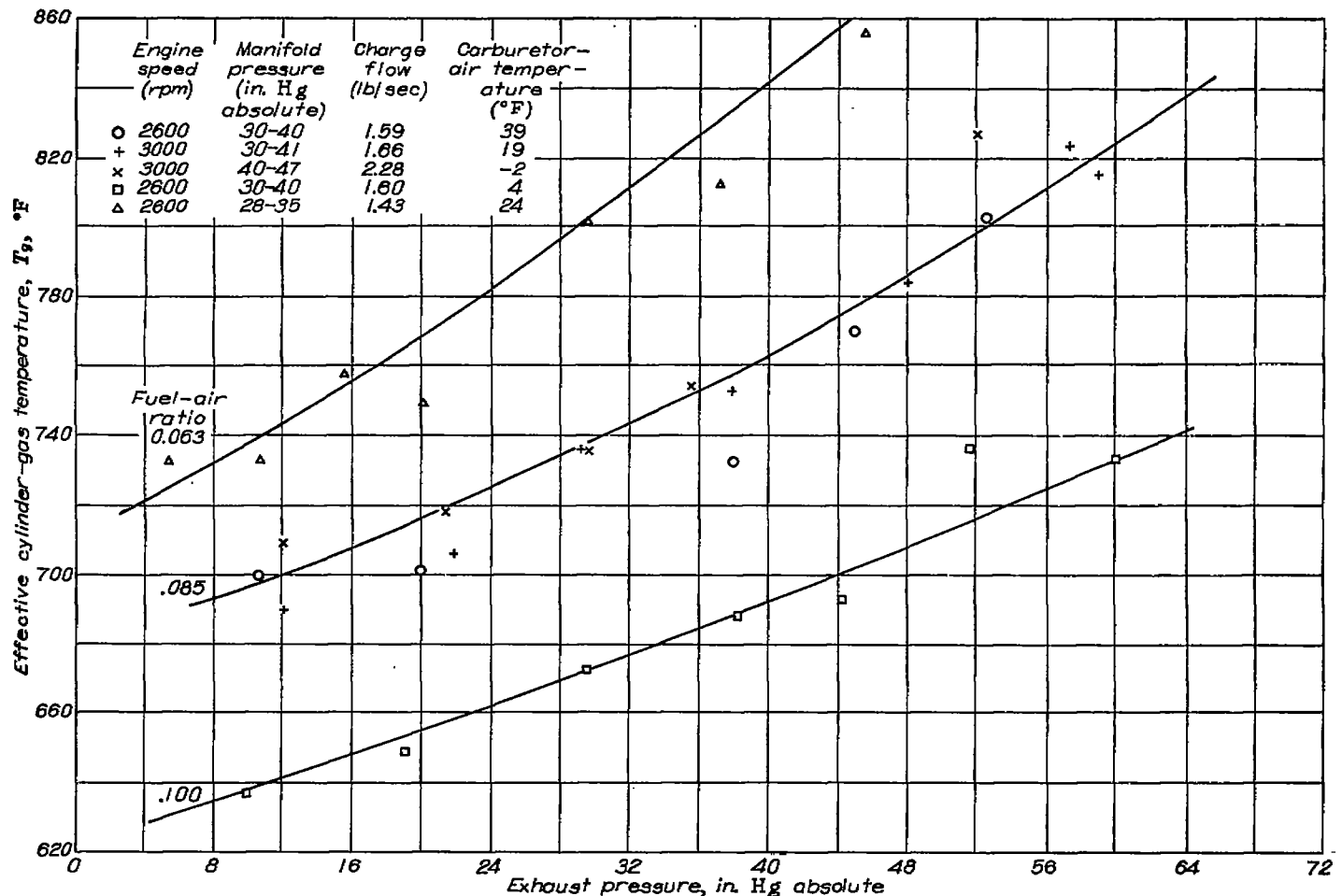

FIGURE 22.—Variation of effective cylinder-gas temperature with exhaust pressure at several fuel-air ratios for coolant-heat-rejection correlation. Data corrected to dry inlet-manifold temperature of 80° F; standard ignition timing.

The effect of exhaust pressure on T_g for three values of fuel-air ratio and a variety of engine conditions is presented in figure 22. All the data have been corrected to an inlet-manifold temperature of 80° F in accordance with equation (20). As for the cylinder-head-temperature correlation, the increase in T_g with increased exhaust pressure is greater at the lean than at the rich mixtures for the range of fuel-air ratios investigated. For convenience, a cross plot of the curves in figure 22 is shown in figure 23 in which T_g is plotted as a function of fuel-air ratio for various exhaust pressures. The curve for an exhaust pressure of 30 inches of mercury was obtained from figure 20 and served as a guide for the fairing of the other curves.

The variation of T_g with ignition timing for engine speeds of 2600 and 3000 rpm is presented in figure 24 as a plot of ΔT_g against ignition timing. This curve has a minimum at an exhaust spark-plug timing of about 30° B.T.C. and increases as the spark is advanced or retarded from this setting.

Exponent n on charge flow W_c and constant B_1 .—The value of the exponent n on charge flow W_c and the constant B_1 were obtained from the series of runs at constant coolant conditions in which the charge flow was varied by changing either the manifold pressure or engine speed. (A summary of the conditions for these runs is given under variable charge

flow in table I.) For such conditions, correlation equation (6) reduces to

$$B_1 \left(\frac{T_g - T_i}{H} \right) - \frac{1}{W_c^n} = \text{constant} \quad (21)$$

According to this equation, a plot of $1/W_c^n$ against $(T_g - T_i)/H$ on rectangular coordinates would define a straight line having a slope equal to the value of B_1 provided that the value of n were properly chosen. Because this method requires a trial-and-error solution and may not be as sensitive as desired, a second method of determining n and B_1 based on equation (1) was used.

According to equation (1), a plot of W_c against $H/(T_g - T_i)$ on logarithmic coordinates would result in a line having a slope equal to n and a value of B_1 determined from the coordinates of any point on the line. These values of n and B_1 may then be verified for use in equation (21), as previously discussed. Such a plot is shown in figure 25, wherein initial values of 0.94 for n and 0.37 for B_1 are obtained.

The plot of $1/W_c^n$ against $(T_g - T_i)/H$, wherein the initial value of 0.94 was substituted for n , is presented in figure 26. A straight line having a slope of 0.37 satisfactorily represents the data and thus the values of 0.94 for n and 0.37 for B_1 are verified. Close agreement is seen to exist between the variable inlet-manifold-pressure and variable engine-speed data.

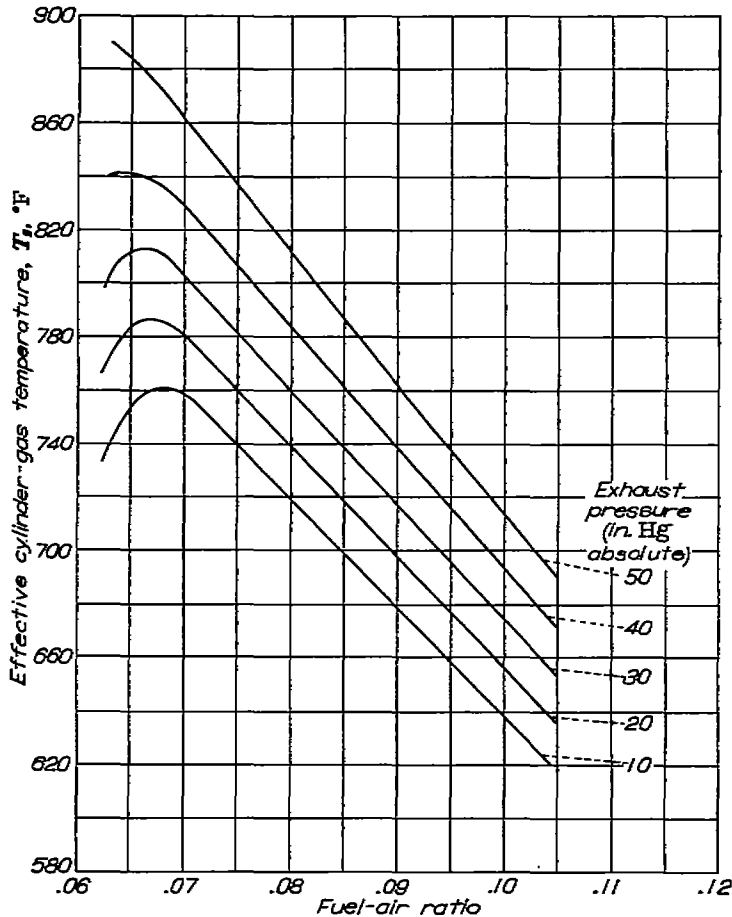

FIGURE 23.—Variation of effective cylinder-gas temperature with fuel-air ratio for various exhaust pressures for coolant-heat-rejection correlation (obtained from cross plot of fig. 22). Data corrected to dry inlet-manifold temperature of 80° F; standard ignition timing.

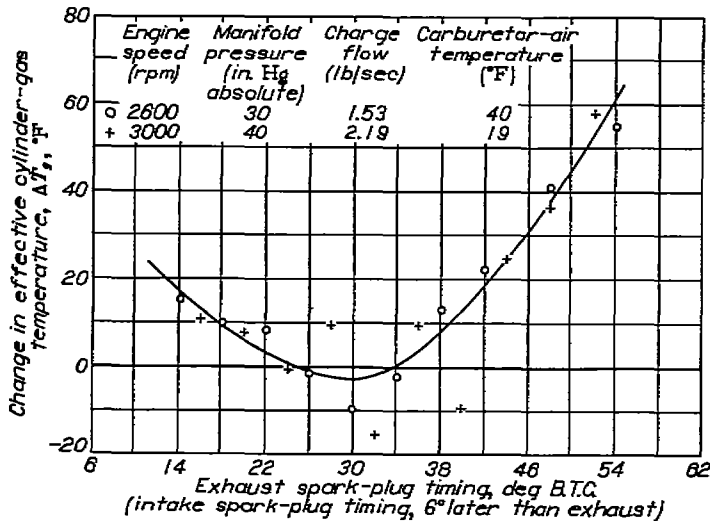

FIGURE 24.—Variation of change in effective cylinder-gas temperature with ignition timing for coolant-heat-rejection correlation. Fuel-air ratio, 0.095.

Factor Z.—For the operating conditions of constant coolant temperature and composition and variable coolant flow \dot{W}_c , which provide data for the determination of the factor Z, equation (6) reduces to

$$B_1 \left(\frac{T_g - T_i}{H} \right) - \frac{1}{\dot{W}_c^n} - Z = B_2 \left(\frac{1}{\dot{W}_c} \right)^m \quad (22)$$

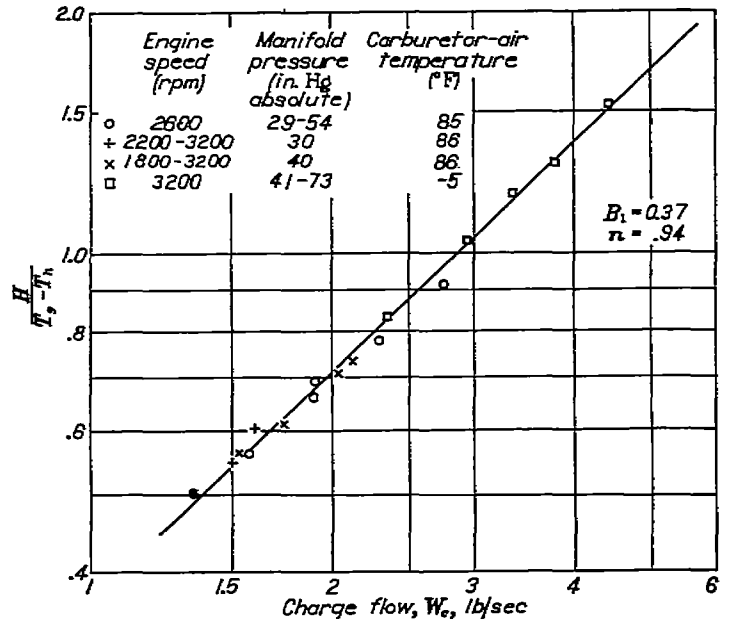

FIGURE 25.—Determination of exponent n and constant B_1 or coolant-heat-rejection correlation from variation of $H/(T_g - T_i)$ with \dot{W}_c . Fuel-air ratio, 0.095; exhaust pressure, 29-30 inches mercury absolute; standard ignition timing.

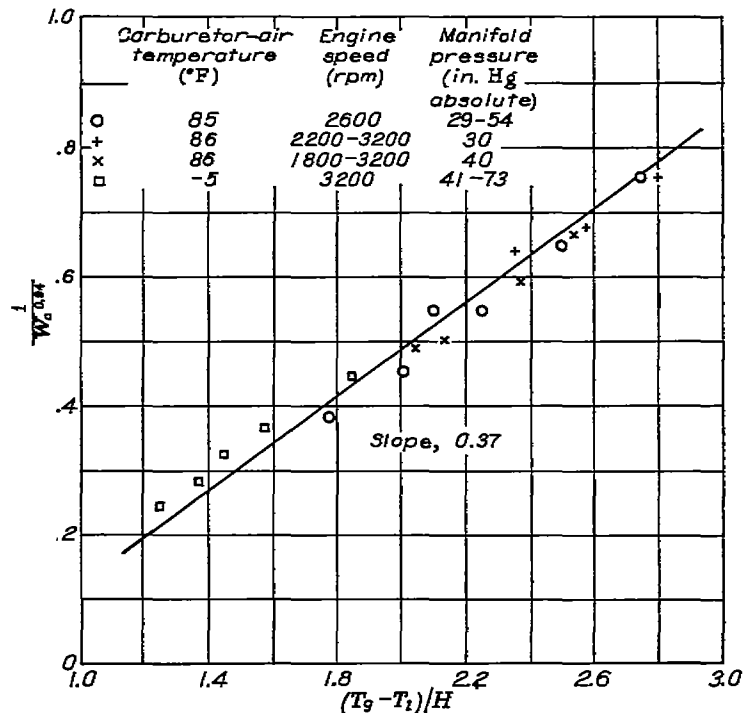

FIGURE 26.—Variation of $1/\dot{W}_c^{0.94}$ with $(T_g - T_i)/H$. Fuel-air ratio, 0.095; exhaust pressure, 29-30 inches mercury absolute; standard ignition timing.

Inspection of this equation indicates that $Z = B_1 \left(\frac{T_g - T_i}{H} \right) - \frac{1}{\dot{W}_c^n}$ when $\frac{1}{\dot{W}_c} = 0$; therefore a plot of $B_1 \left(\frac{T_g - T_i}{H} \right) - \frac{1}{\dot{W}_c^n}$ against $\frac{1}{\dot{W}_c}$ using the previously determined values of B_1 , n , and T_g would give an indication of the value of the Z factor when extrapolated to zero $1/\dot{W}_c$. Such a plot is shown in figure 27 for five different coolants at two engine powers and a value of 0.12 is indicated for Z. As for the cylinder-head-temperature correlation, several values in the neighborhood

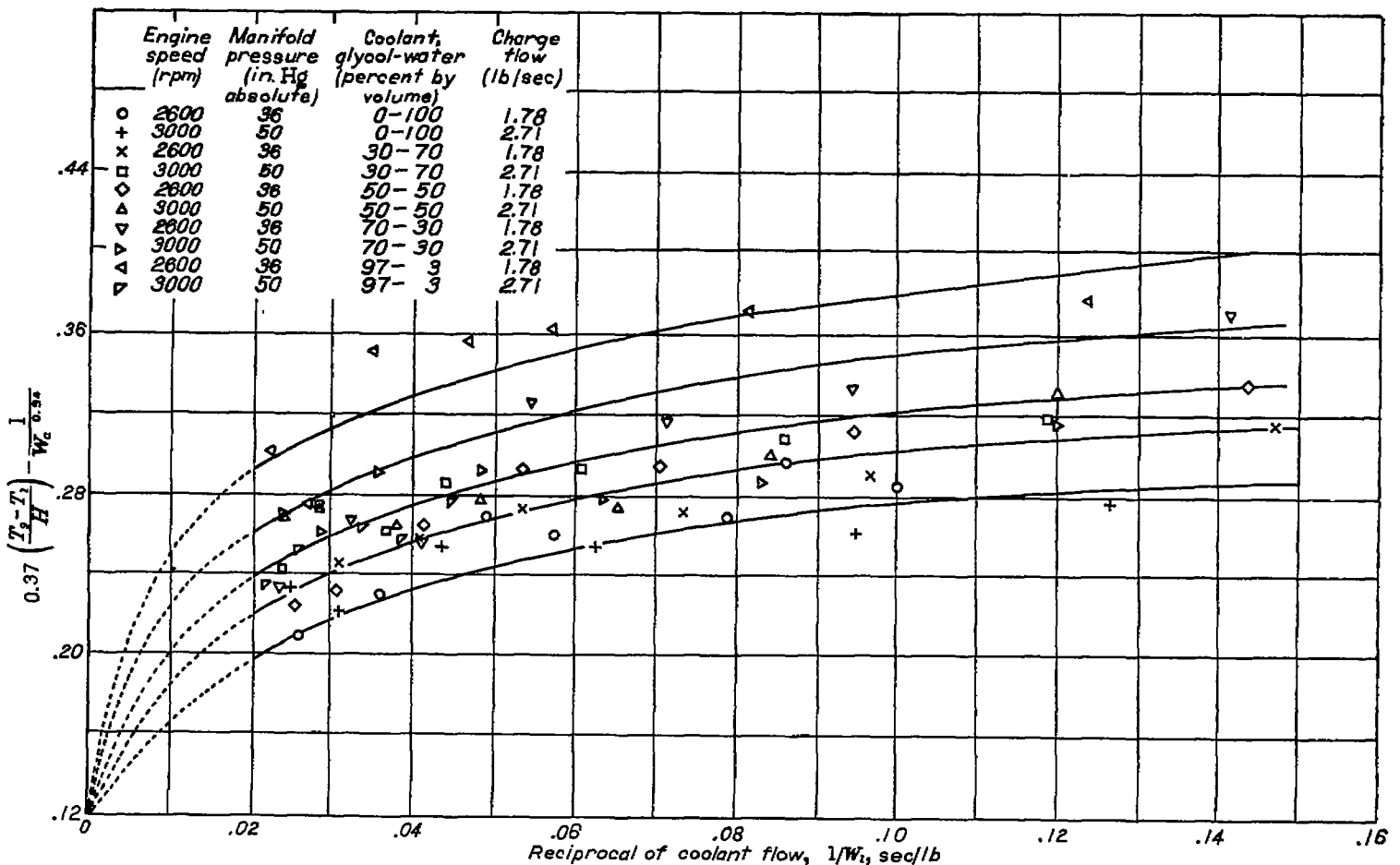

FIGURE 27.—Determination of factor Z for coolant-heat-rejection correlation from variation of $0.37 \left(\frac{T_s - T_i}{H} \right) - \frac{1}{W_c^{0.34}}$ with $\frac{1}{W_i}$. Average coolant temperature, 245° F.

of 0.12 were chosen for Z and used in trial correlation plots; the value that gave the most satisfactory correlation (0.12) was finally used.

Although it would be expected that the scaling of the coolant passages in the hot regions of the cylinder head (illustrated by the temperature curves of fig. 10) would have an effect on the coolant heat rejection similar to that which it had on the cylinder-head-temperature correlation (fig. 11), no such effect could be detected within the accuracy of the data. It is likely, however, that the effect of this scaling on the heat-rejection correlation is less than those for the head-temperature correlation because the scale was deposited in only a portion of the cylinder head and thus would not have as great an effect on the total coolant heat rejection as it did on the cylinder-head temperature between the exhaust valves.

Exponent m on coolant-flow parameter W_i/μ .—For the determination of the exponent m on the coolant-flow parameter W_i/μ , data similar to that used for the determination of Z are used and equation (6) may be accordingly written

$$\left[B_1 \left(\frac{T_s - T_i}{H} \right) - \frac{1}{W_c^{0.34}} - Z \right] k = B_2 \left(\frac{W_i}{\mu} \right)^{-m} \quad (23)$$

A logarithmic plot of the factor

$$\left[0.37 \left(\frac{T_s - T_i}{H} \right) - \frac{1}{W_c^{0.34}} - 0.12 \right] k$$

against W_i/μ , in which the absolute value of the slope of the straight line through the data will be equal to the exponent m , is shown in figure 28 for five different coolants. Lines having the same slope are drawn through the data for each coolant and the value of the exponent m is thus established as 0.26. This value of the exponent m , which is established from selected data, will be verified by the slope of the line through all the data in the final correlation plot based on equation (6).

Exponent s on Prandtl number Pr .—The value of the exponent s on the Prandtl number Pr was determined from data for a constant value of W_i/μ , which permits the reduction of equation (6) to

$$\left[B_1 \left(\frac{T_s - T_i}{H} \right) - \frac{1}{W_c^{0.34}} - Z \right] k = B_{10} (Pr)^{-s} \quad (24)$$

The slope of the line determined by a logarithmic plot of $\left[0.37 \left(\frac{T_s - T_i}{H} \right) - \frac{1}{W_c^{0.34}} - 0.12 \right] k$ against Pr would then establish the value of the exponent s .

Following a procedure similar to that used in the head-temperature correlation, values of the factor

$$\left[0.37 \left(\frac{T_s - T_i}{H} \right) - \frac{1}{W_c^{0.34}} - 0.12 \right] k$$

are obtained from figure 28 for each of the coolants at a constant value of W_i/μ and are then cross-plotted against the Prandtl number Pr for the different coolants. Data so obtained from a cross plot of figure 28 at a constant value of W_i/μ equal to 55,000 are shown in figure 29 and the slope of the resulting line establishes the value of the exponent s on the Prandtl number Pr as 0.38.

FINAL CORRELATION

Final correlation with coolant-flow factor W_i/μ as independent variable.—The final correlation based on equation (6), which is obtained by plotting the factor

$$\left[0.37 \left(\frac{T_g - T_i}{H} \right) - \frac{1}{W_c^{0.94}} - 0.12 \right] k (Pr)^{0.38}$$

against W_i/μ on logarithmic coordinates for all the data, is presented in figure 30. Although the data points scatter considerably, the variation in terms of the coolant heat rejection is not excessive. Dashed lines representing a variation in heat rejection of ± 5 percent are drawn on the figure and practically all the data are seen to fall within these limits. The effect of boiling of the coolant on this

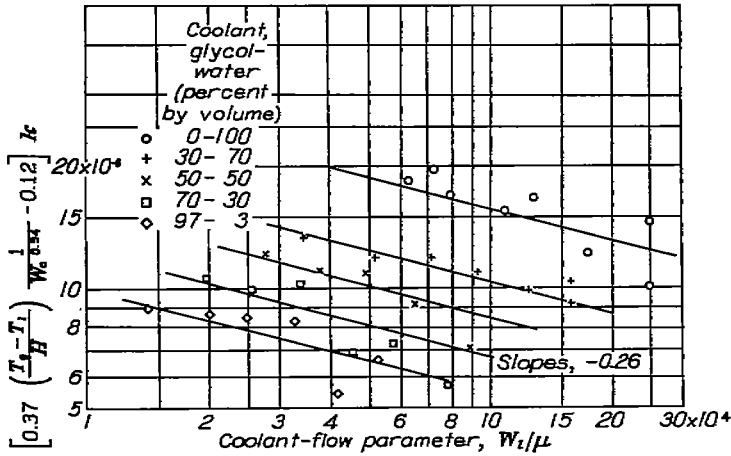

FIGURE 28.—Determination of exponent m on coolant-flow parameter W_i/μ for coolant-heat-rejection correlation from variation of $\left[0.37 \left(\frac{T_g - T_i}{H} \right) - \frac{1}{W_c^{0.94}} - 0.12 \right] k$ with $\frac{W_i}{\mu}$ for various coolants. Average coolant temperature, 245° F.

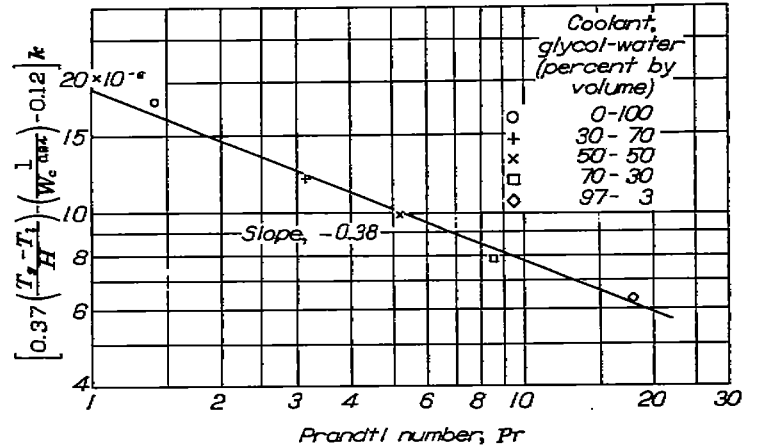

FIGURE 29.—Determination of exponent s on Prandtl number Pr for coolant-heat-rejection correlation from variation of $\left[0.37 \left(\frac{T_g - T_i}{H} \right) - \frac{1}{W_c^{0.94}} - 0.12 \right] k$ with Pr as obtained from cross plot of figure 28 at value of $\frac{W_i}{\mu}$ of 55,000. Average coolant temperature, 245° F.

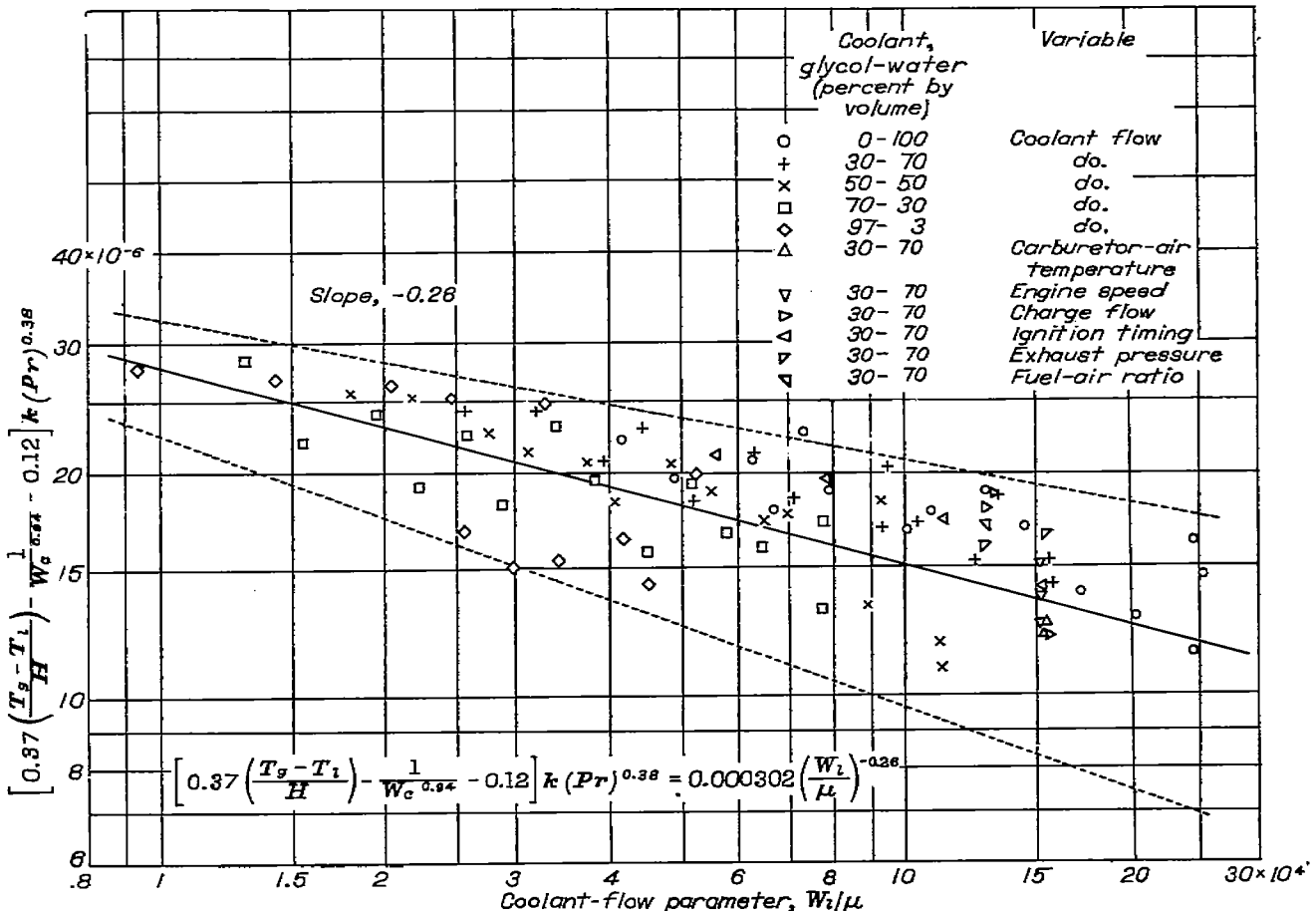

FIGURE 30.—Final correlation of coolant heat rejections based on equation (6).

correlation, which, as illustrated in figure 17, had a small influence on the cylinder-head-temperature correlation, could not be detected within the accuracy of the data. Because the region in which boiling of the coolant occurred was probably limited to a relatively small area of the cylinder head, it would be expected to have a much smaller effect on the total coolant heat rejections than on the cylinder-head temperatures.

The value of the exponent m , which is equal to the absolute value of the slope of the line through the data, is, as previously determined, equal to 0.26, and the value of the constant B_3 , found by the substitution of the values of the coordinates of any point on the line into the correlation equation, is equal to 0.000302. The final equation is accordingly written

$$\left[0.37 \left(\frac{T_g - T_i}{H} \right) - \frac{1}{W_c^{0.94}} - 0.12 \right] k(P_r)^{0.38} = 0.000302 \left(\frac{W_i}{\mu} \right)^{-0.26} \quad (25)$$

and will apply over the range of engine operating conditions and coolant conditions listed in table I.

Final correlation with charge flow W_c as independent variable.—Correlation of the test data based on equation (7), which is obtained by plotting the factor

$$0.37 \left(\frac{T_g - T_i}{H} \right) - \left(\frac{0.000302}{W_c^{0.26}} \right) \left(\frac{\mu^{0.26}}{k(P_r)^{0.38}} \right) - 0.12$$

against W_c on logarithmic coordinates, is presented in figure 31. A straight line with a slope of -0.94 , which is equal to the value of the exponent on W_c previously determined, is drawn through the data. When equation (25) is

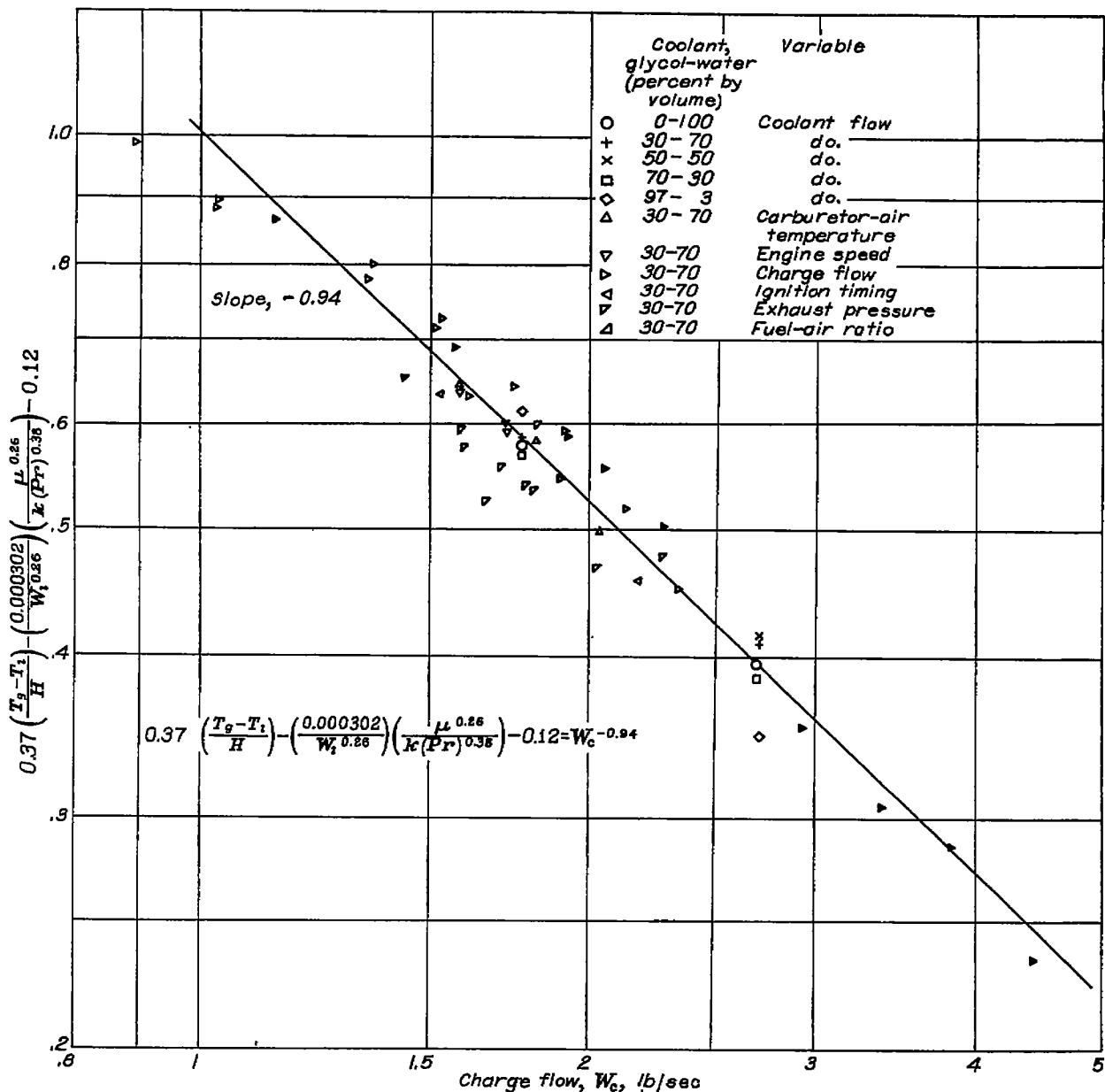

FIGURE 31.—Final correlation of coolant heat rejections based on equation (7).

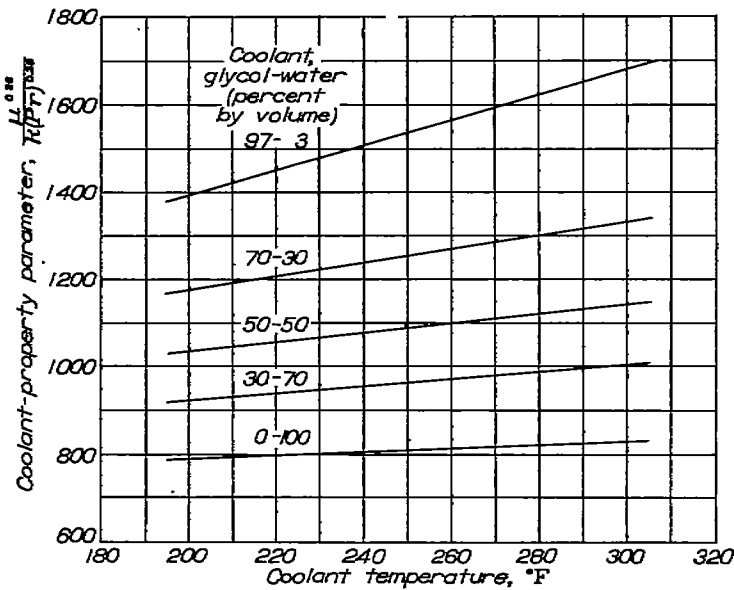

FIGURE 32.—Variation with coolant temperature of coolant-property parameter $\mu^{0.26}/k(Pr)^{0.38}$ for coolant-heat-rejection correlation.

rearranged in accordance with this plot, the following form is obtained:

$$0.37 \left(\frac{T_g - T_i}{H} \right) - \left(\frac{0.000302}{W_c^{0.26}} \right) \left(\frac{\mu^{0.26}}{k(Pr)^{0.38}} \right) - 0.12 = W_c^{-0.94} \quad (26)$$

In order to facilitate the computation of coolant heat rejections by means of this equation, values of the coolant-property parameter $\mu^{0.26}/k(Pr)^{0.38}$ are presented in figure 32 for various ethylene glycol—water solutions over a range of coolant temperatures.

USE OF CORRELATION EQUATIONS

In order to illustrate the use of the correlation equations, the following example is presented:

The maximum cylinder-head temperature between the exhaust valves and the coolant heat rejection are to be determined for the following conditions:

Engine charge flow (air plus fuel), lb/sec.....	3.0
Engine speed, rpm.....	3000
Fuel-air ratio.....	0.095
Carburetor-inlet air temperature, °F.....	60
Exhaust pressure, in. Hg absolute.....	40.0
Ignition timing (exhaust spark plugs), deg B.T.C.....	40
Accumulated engine running time, hr.....	Over 100
Coolant flow, lb/sec.....	30.0
Average coolant temperature, °F.....	250
Coolant composition, ethylene glycol—water (percent by volume).....	30-70

Determination of maximum cylinder-head temperature.—

The average cylinder-head temperature is first evaluated from equation (18) and the maximum cylinder-head temperature then determined from figure 18. Although either equation (17) or (18) may be used to evaluate the average cylinder-head temperature, the grouping of the coolant-

property terms of equation (18) results in greater convenience of application.

The dry inlet-manifold temperature is computed from the carburetor-air temperature and the engine speed by means of equation (9) as follows:

$$\begin{aligned} T_m &= T_c + 25.28 \left(\frac{N}{1000} \right)^2 \\ &= 60 + 25.28 \left(\frac{3000}{1000} \right)^2 \\ &= 288^\circ \text{F} \end{aligned}$$

In order to determine the effective cylinder-gas temperature T_g , a value of T_g is first determined from figure 6 as 1069°F for a fuel-air ratio of 0.095, an exhaust pressure of 40 inches of mercury absolute, standard ignition timing, and a dry inlet-manifold temperature of 80°F . The correction for an ignition timing of 40°B.T.C. is obtained from figure 7 as 24°F . For a dry inlet-manifold temperature of 288°F , the correction to T_g is determined from equation (11)

$$\begin{aligned} \Delta T_g &= 0.25 (T_m - 80) \\ &= 0.25 (288 - 80) \\ &= 52^\circ \text{F} \end{aligned}$$

The value of T_g is then determined by algebraically adding the corrections for ignition timing and manifold temperature to the value obtained from figure 6.

$$T_g = 1069 + 24 + 52 = 1145^\circ \text{F}$$

Because the variation of Z with engine running [time was shown to be constant at a value of 0.13 (fig. 11) for any engine running time over 100 hours, this constant value is used. The coolant-property parameter $\left(\frac{\mu^{0.48}}{k(Pr)^{0.38}} \right)$ is determined from figure 16 for the specified coolant and coolant temperature as equal to 164.

Substitution of the values of the various parameters into equation (18)

$$\left(\frac{T_g - T_h}{T_h - T_i} \right) \left[\left(\frac{0.00163}{W_c^{0.48}} \right) \left(\frac{\mu^{0.48}}{k(Pr)^{0.38}} \right) + Z \right] = W_c^{-0.60} \quad (18)$$

gives the following:

$$\left(\frac{1145 - T_h}{T_h - 250} \right) \left[\left(\frac{0.00163}{30^{0.48}} \right) (164) + 0.13 \right] = 3.0^{-0.60}$$

$$2.839 T_h + T_h = 1145 + 2.839 \times 250$$

$$T_h = 483^\circ \text{F}$$

For this value of the average cylinder-head temperature, the maximum cylinder-head temperature between the exhaust valves is found to be 499°F (fig. 18).

Determination of coolant heat rejection.—As for the cylinder-head temperature, the determination of the coolant heat rejection is most conveniently accomplished by using the equation in which the charge flow is the separated variable; equation (26) will therefore be used.

As previously calculated for the cylinder-head-temperature determination, the dry inlet-manifold temperature is 288° F. A value of T_g for a fuel-air ratio of 0.095, an exhaust pressure of 40 inches of mercury absolute, standard ignition timing, and a dry inlet-manifold temperature of 80° F is first determined from figure 23 as 716° F. The correction for an ignition timing of 40° B.T.C. is obtained from figure 24 as 14° F. For a dry inlet-manifold temperature of 288° F, the correction to T_g is determined from equation (20).

$$\begin{aligned}\Delta T_g &= 0.30 (T_m - 80) \\ &= 0.30 (288 - 80) \\ &= 62.4^\circ \text{ F}\end{aligned}$$

The value of T_g is then determined by algebraically adding the corrections for ignition timing and manifold temperature to the value obtained from figure 23.

$$T_g = 716 + 14 + 62.4 = 792.4^\circ \text{ F}$$

The coolant-property parameter $\left(\frac{\mu^{0.28}}{k(P_r)^{0.38}}\right)$ is determined from figure 32 for the specified coolant and coolant temperature and is equal to 964.

Substitution of the values of the various parameters into equation (26)

$$0.37 \left(\frac{T_g - T_i}{H}\right) - \left(\frac{0.000302}{W_i^{0.26}}\right) \left(\frac{\mu^{0.28}}{k(P_r)^{0.38}}\right) - 0.12 = W_c^{-0.94} \quad (26)$$

gives the following:

$$0.37 \left(\frac{792.4 - 250}{H}\right) - \left(\frac{0.000302}{30^{0.26}}\right) (964) - 0.12 = 3.0^{-0.94}$$

$$\frac{200.7}{H} - 0.120 - 0.12 = 0.3561$$

$$H = 336.6 \text{ Btu per second}$$

SUMMARY OF RESULTS

An analysis of the data obtained from multicylinder, liquid-cooled engines of 1710-cubic-inch displacement, which included power outputs from 275 to 1860 brake horsepower,

coolant flows from 50 to 320 gallons per minute, and coolants composed of ethylene glycol—water mixtures varying in composition from 100 percent water to 97 percent ethylene glycol and 3 percent water gave the following results:

1. The NACA correlation method, which is based on the theory of heat transfer by normal forced convection, provided satisfactory correlation of both the cylinder-head temperature between the exhaust valves and the coolant heat rejection with the primary engine and coolant variables for a wide range of engine and coolant conditions.

2. The correlation method as applied herein permitted the prediction of the cylinder-head temperature between the exhaust valves within approximately $\pm 12^\circ \text{ F}$ and of the coolant heat rejection with an accuracy of ± 5 percent.

3. Boiling of the coolant, which was encountered at several engine powers under certain conditions of coolant flow, coolant temperature, and coolant composition, was found to have an effect on the cylinder-head temperatures. For the ranges of variables covered in this investigation, however, this boiling of the coolant did not seriously affect the cylinder-head-temperature correlation and had no detectible effect on the heat-rejection correlation.

FLIGHT PROPULSION RESEARCH LABORATORY,
NATIONAL ADVISORY COMMITTEE FOR AERONAUTICS,
CLEVELAND, OHIO, August 31, 1948.

REFERENCES

1. Pinkel, Benjamin, Manganiello, Eugene J., and Bernardo, Everett: Cylinder-Temperature Correlation of a Single-Cylinder Liquid-Cooled Engine. NACA Rep. 853, 1946.
2. Pinkel, Benjamin: Heat-Transfer Processes in Air-Cooled Engine Cylinders. NACA Rep. 612, 1938.
3. Povolny, John H., and Chelko, Louis J.: Cylinder-Head Temperatures and Coolant Heat Rejections of a Multicylinder, Liquid-Cooled Engine of 1710-Cubic-Inch Displacement. NACA TN 1606, 1948.
4. Cragoe, C. S.: Properties of Ethylene Glycol and Its Aqueous Solutions. Cooperative Fuel Res. Comm., CRC, July 1943.
5. Manganiello, Eugene J., Valerino, Michael F., and Bell, E. Barton: High-Altitude Flight Cooling Investigation of a Radial Air-Cooled Engine. NACA Rep. 873, 1947.
6. Valerino, Michael F., Kaufman, Samuel J., and Hughes, Richard F.: Effect of Exhaust Pressure on the Cooling Characteristics of an Air-Cooled Engine. NACA TN 1221, 1947.
7. Pinkel, Benjamin, and Ellerbrock, Herman H., Jr.: Correlation of Cooling Data from an Air-Cooled Cylinder and Several Multicylinder Engines. NACA Rep. 683, 1940.

TABLE I—SUMMARY OF ENGINE AND COOLANT CONDITIONS

Variable or type of test	Engine power (bhp)	Engine speed (rpm)	Manifold pressure (in. Hg absolute)	Charge flow (lb/sec)	Fuel-air ratio	Carburetor-air temperature (°F)	Ignition timing (deg B.T.C.)		Exhaust pressure (in. Hg absolute)	Dry inlet-manifold temperature (°F)	Coolant, ethylene glycol—water (percent by volume)		Coolant flow (gal/min)	Average coolant temperature (°F)	Engine coolant-outlet pressure (lb/sq in. gage)	Engine	Correlation used in		Engine running time (hr)
							Exhaust	Intake			Glycol	Water					Temperature	Heat-rejection	
Charge flow.....	400-1180	2800	24-48	1.08-2.47	0.080	60	34	28	281	80	70	255	245	38	O	x	88.9-45.8		
	275-1260	2800	21-54	.84-2.74	.095	85	34	28		258	80	70	250	245		35		x	
	553-1260	2800	29-54	1.85-2.78	.095	85	34	28		258	80	70	250	245		35		x	
	925-1860	3200	41-73	2.85-4.40	.095	-5	34	28		254	80	70	300	245		35		x	153.8-166.5
	860-940	2800-3200	40	1.70-2.18	.080	60	34	28		28-80	194-319	80	70	255		245		33	x
	750-878	1800-3200	40	1.64-2.14	.095	86	34	28		108-345	80	70	250	245		35		x	47.2-51.2
	430-630	1400-3200	30	.88-1.60	.095	84	34	28		138-345	80	70	250	245		35		x	45.8-47.2
	610-690	2200-3200	30	1.35-1.60	.095	86	34	28		208-345	80	70	250	245		35		x	
	870-840	1200-3200	30	.78-1.57	.080	60	34	28		96-319	80	70	255	245		30		x	
	786-794	2800	34-36	1.88	.095	80-184	34	28		223-275	80	70	230	245		25		x	
Manifold temperature.....	585-590	2800	27-30	1.39	.090	-20-170	34	28	151-341	80	70	270	245	30	x				
	659-675	2800	30-34	1.58	.095	-27-144	34	28	144-315	80	70	300	245	35	x	15.2-19.7			
	798-848	3000	36-40	2.04	.095	-43-146	34	28	185-374	80	70	300	245	35	x	19.7-24.5			
	632-825	2800-3200	32-36	1.72	.080	17	34	28	151-276	80	70	300	245	35	x	24.5-28.3			
	847-812	2800-3200	34-40	1.72	.080	140	34	28	274-309	80	70	300	245	35	x	28.3-31.2			
	602-898	2000-3200	32-40	1.76	.085	17	34	28	118-276	80	70	300	245	35	x	31.2-33.7			
	546-742	2000-3200	31-40	1.58	.095	149	34	28	244-402	80	70	300	245	35	x	33.7-35.8			
	740-790	2800	35	1.75	.084-118	66	34	28	287	80	70	270	245	35	x				
	731-637	2800	34-36	1.54	.082-109	120	34	28	299-250	80	70	320	245	27	x				
	780-980	3000	39-41	2.21	.084-118	25	34	28	253	80	70	250	245	35	x	37.5-38.9			
Ignition timing.....	877-858	2800	30	1.53	.095	40	14-54	8-48	211	80	70	300	245	35	x	112.2-116.1			
	790-922	3000	40	2.19	.095	19	16-52	10-46	247	80	70	300	245	35	x	116.1-119.8			
	540-612	2800	28-36	1.48	.083	24	34	28	6-45	195	80	250	245	35	x	148.5-151.4			
	598-708	2800	30-40	1.60	.100	4	34	28	10-60	175	80	250	245	35	x	142.3-145.8			
	620-726	2800	30-42	1.59	.085	39	34	28	10-61	210	80	250	245	35	x	136.5-185.5			
	647-736	2800	30-40	1.59	.085	39	34	28	10-62	210	80	250	245	35	x				
	944-694	3000	40-47	2.28	.085	-2	34	28	12-52	250	80	250	245	35	x	140.6-142.2			
	592-632	3000	30-41	1.66	.085	19	34	28	12-59	247	80	250	245	35	x	138.5-140.6			
	427-652	2800	35	1.36-1.92	.085	32	34	28	10-61	208	80	250	245	35	x	145.8-145.5			
	1000	2800	44	2.21	.092	75	34	28	246	97	3	200-300	215, 245, 270	10	x				
Coolant flow.....	780, 1160	2800, 3000	36, 60	1.78, 2.71	.095	83	34	28	251	0	100	50-300	245	35	x	85.6-90.7			
	790, 1160	2800, 3000	36, 60	1.78, 2.71	.095	83	34	28	254, 311	80	70	50-300	245	35	x	90.7-95.3			
	780, 1160	2800, 3000	36, 60	1.78, 2.71	.095	83	34	28	254, 311	50	80	50-300	245	35	x	95.3-99.1			
	780, 1160	2800, 3000	36, 60	1.78, 2.71	.095	83	34	28	254, 311	70	80	50-300	245	35	x	99.1-103.1			
	780, 1160	2800, 3000	36, 60	1.78, 2.71	.095	83	34	28	254, 311	97	3	50-300	245	35	x	103.1-110.2			
	755	2800	36	1.80	.095	83	34	28	264	80	70	200	149-233	35	x				
	795	2800	37	1.84	.095	83	34	28	264	80	70	200	150-309	35	x				
	1000, 1250, 1450	3000	42, 51, 60	2.89, 2.94, 3.40	.095	80	34	28	278	97	3	220	245, 270	20, 25, 35, 65	x				
	310-1200	2000-3000	24-33	.73-2.80	.064-.096	76	34	28	176-303	97	3	144-255	245	10-80	x				

1 Engine equipped with aftercooler.
2 AN-E-2 ethylene glycol.

