

ERRATA NO. 1

THIRTY-SEVENTH ANNUAL REPORT
OF THE
NATIONAL ADVISORY COMMITTEE FOR AERONAUTICS
1951

REPORT 1028

Page 663, column 1: In equation (38a), the last bracketed expression should be corrected as follows:

$$\left[3\beta^2 + 6 - 4x_0(2 + \beta^2) \right]$$

Page 663, column 2: In equation (38b), the last bracketed expression should be corrected as follows:

$$\left[(\beta^2 + 4)(4 - 5x_0) \right]$$

Page 665, column 2: In equation (45c), the factor 2 preceding the second parenthesis should be deleted; that is, the second term within the bracket should read

$$- (1 - 2x_0) \left(\bar{F}_1 + \bar{G}_1 \right)$$

Page 665, column 2: Equation (46a) should be corrected to read as follows:

$$M_1 = - \left\{ \frac{4}{\beta\pi} \left[(1 - 2x_0) \left(\bar{F}_1 + \bar{G}_1 \right) + \frac{2x_0(2\beta^2 + 1)}{\beta^2} \left(\bar{F}_2 + \bar{G}_2 \right) - \frac{3\beta^2 + 2}{\beta^2} \left(\bar{F}_3 + \bar{G}_3 \right) \right] + \frac{2}{3\beta^3} (2 - 3x_0) \right\}$$

It is pointed out that the foregoing errors have been corrected in a subsequent NACA publication (NACA TN 3076 by Nelson, Rainey, and Watkins).

REPORT 1028

EFFECT OF ASPECT RATIO ON THE AIR FORCES AND MOMENTS OF HARMONICALLY OSCILLATING THIN RECTANGULAR WINGS IN SUPERSONIC POTENTIAL FLOW¹

By CHARLES E. WATKINS

SUMMARY

This report treats the effect of aspect ratio on the air forces and moments of an oscillating flat rectangular wing in supersonic potential flow. The linearized velocity potential for the wing undergoing sinusoidal torsional oscillations simultaneously with sinusoidal vertical translations is derived in the form of a power series in terms of a frequency parameter. The series development is such that the differential equation for the velocity potential is satisfied to the required power of the frequency parameter considered and the linear boundary conditions are satisfied exactly. The method of solution can be utilized for other plan forms—that is, plan forms for which certain steady-state solutions are known.

Simple, closed expressions that include the reduced frequency to the third power, which is sufficient for application to a large class of practicable problems, are given for the velocity potential, the components of total force and moment coefficients, and the components of chordwise section force and moment coefficients. The components of total force and moment coefficients indicate the over-all effect of aspect ratio on these quantities; however, the components of chordwise coefficients yield more information because they account for the spanwise distribution of aerodynamic loading of a rectangular wing and may therefore be more useful for flutter calculations. It is found that the components of force and moment coefficients for a small-aspect-ratio wing may deviate considerably from those of an infinite-aspect-ratio wing. Thickness effects which may alter some of the conclusions are not taken into account in the analysis. Results of some selected calculations are presented in several figures and discussed.

INTRODUCTION

The effect of aspect ratio on the single-degree torsional instability of a finite rectangular wing oscillating in a supersonic stream was treated in reference 1 by expanding, in powers of the frequency of oscillation, the linearized velocity potential developed in reference 2. Since only slow oscillations were considered pertinent to single-degree torsional instability, terms in the expansion involving the frequency of oscillation to powers higher than the first were not considered.

In the present report the expanded linearized velocity potential is used to study the effect of aspect ratio on the air

forces and moments of an oscillating, thin, flat, finite, rectangular wing when higher powers of the frequency of oscillation are taken into account. The motions considered are sinusoidal torsional oscillations about a spanwise axis taken simultaneously with sinusoidal vertical translations of this axis. The velocity potential is developed by use of sources and doublets, so as to include all powers of the frequency of oscillations up to any desired power. Simple, closed expressions are given for the velocity potential, components of the total force and moment coefficients, and components of the chordwise section force and moment coefficients involving powers of the frequency up to and including the third power. Extension of the results to include higher powers of the frequency is straightforward.

A recent publication, reference 3, that became available after this investigation was completed, is partly devoted to the treatment of a rectangular wing undergoing the same types of harmonic motions as those considered herein. The velocity potential is determined in the form of a double integral, by application of the Fourier transform to the boundary-value problem for this potential, and expressions for forces and moments are given in terms of this double integral. The reduction of the integral expressions of reference 3 to forms desirable for flutter calculations—that is, chordwise section forces and moments—is not given.

SYMBOLS

ϕ	disturbance-velocity potential
x, y, z	rectangular coordinates attached to wing moving in negative x -direction
ξ, η	rectangular coordinates used to represent space location of sources or doublets in xy -plane
Z_m	function defining mean ordinates of any chordwise section of wing such as $y=y_1$ as shown in figure 1
$w(x, y_1, t)$	vertical velocity at surface of wing along chordwise section at $y=y_1$
x_0	abscissa of axis of rotation of wing (elastic axis) as shown in figure 1
t	time
h	vertical displacement of axis of rotation
h_0	amplitude of vertical displacement of axis of rotation, positive downward

¹ Supersedes NACA TN 2064, "Effect of Aspect Ratio on the Air Forces and Moments of Harmonically Oscillating Thin Rectangular Wings in Supersonic Potential Flow" by Charles E. Watkins, 1950.

α	angle of attack
α_0	amplitude of angular displacement about axis of rotation, positive leading edge up
$h, \dot{\alpha}$	time derivative of h and α , respectively
V	velocity of main stream
c	velocity of sound
M	free-stream Mach number (V/c)
$\beta = \sqrt{M^2 - 1}$	
$\tau_1, \tau_2, \eta_1, \eta_2$	functions defined with equation (7)
$W(\xi, \eta)$	function used to represent space variation of source and doublet strengths
$w(t)$	function used to represent time variation of source and doublet strengths
ω	frequency of oscillation
$\bar{\omega} = \frac{M^2 \omega}{V \beta^2}$	
k	reduced frequency ($\omega b/V$)
$R = \beta \sqrt{(\eta_1 - \eta_2)(\eta_2 - \eta_1)}$	
a_{nm}	represents functions of $\bar{\omega}$, x , and M , defined in equations (15)
f_1, f_2, f_3	represent functions of x , x_0 , and $\bar{\omega}$, defined in equations (19)
D_n	function used to denote doublet distributions (see equation (22))
F_n	function defined in equation (28)
G_n	function defined in equation (29)
ρ	density
Δp	local pressure difference measured positive downward, defined in equation (31)
b	half-chord
s	half-span
A	aspect ratio (s/b)
\bar{P}	total force acting on wing defined in equation (32)
$\bar{L}_1, \bar{L}_2, \bar{L}_3, \bar{L}_4$	components of total force coefficients, defined in equations (35)
\bar{M}_α	total moment acting on wing, defined in equation (36)
$\bar{M}_1, \bar{M}_2, \bar{M}_3, \bar{M}_4$	components of total moment coefficients, defined in equations (38)
P	section force (total force at any spanwise station), defined in equation (39)
L_1, L_2, L_3, L_4	components of section force coefficients, defined in equations (41) and (42)
M_α	section moment (total moment at any spanwise station), defined in equation (40)
M_1, M_2, M_3, M_4	components of section moment coefficients, defined in equations (43) and (44)
\bar{F}_n, \bar{G}_n	functions related to F_n and G_n , defined in appendix

ANALYSIS

BOUNDARY-VALUE PROBLEMS FOR VELOCITY POTENTIALS

Consider a thin flat rectangular wing moving at a constant supersonic speed in a chordwise direction normal to its leading edge as shown in figure 1. The boundary-value problems for the velocity potential for such a wing may be conveniently classified into two types associated with the nature of the flow over different portions of the wing. On the portion of the wing between the Mach cones emanating from the foremost point of each tip (region N in fig. 1 (a)) there is no interaction between the flow on the upper and lower surfaces of the wing. The type of boundary-value problem

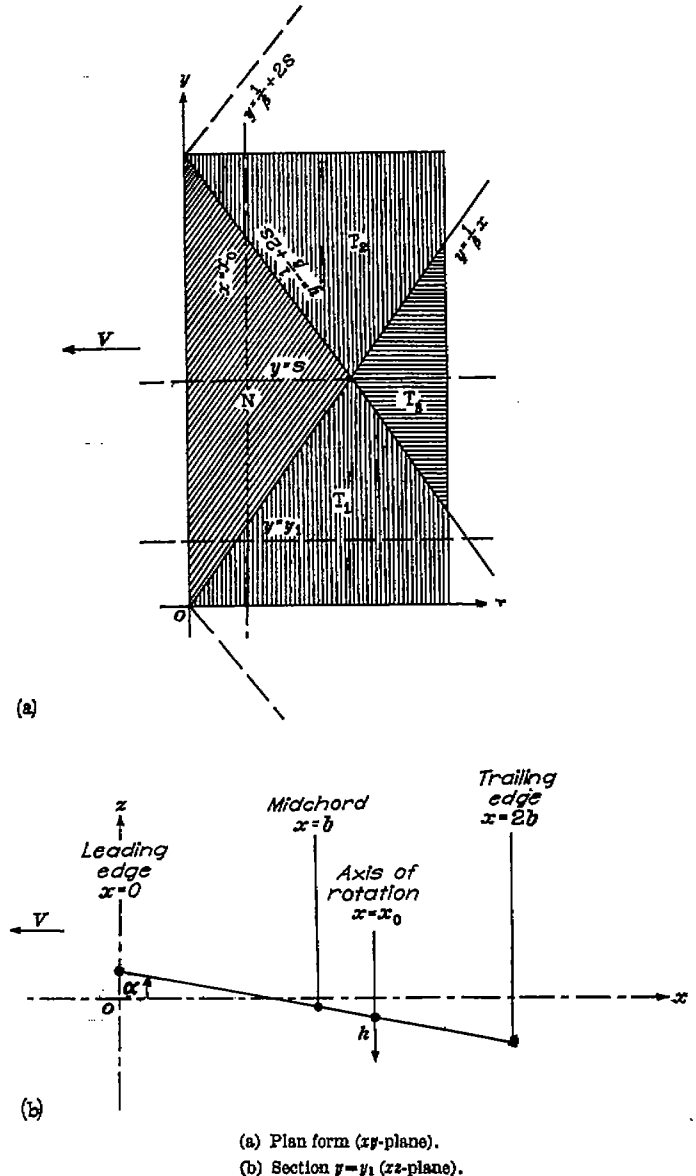

FIGURE 1.—Sketch illustrating chosen coordinate system and the two degrees of freedom α and h .

for this portion of the wing is referred to herein as "purely supersonic" and the velocity potential for region N is denoted by ϕ_N . On portions of the wing within the Mach cones emanating from the foremost point of each tip (regions T₁, T₂, and T₃ in fig. 1 (a)), there is interaction between the flow on the upper and lower surfaces of the wing. The type of boundary-value problem for these portions of the wing is referred to as "mixed supersonic" and the velocity potentials for these regions are designated by ϕ_{T_1} , ϕ_{T_2} , and ϕ_{T_3} , respectively. The complete velocity potential at a point may then be expressed as ϕ_N , ϕ_{T_1} , ϕ_{T_2} , or ϕ_{T_3} according to the region that contains the point.

As customary in linear theory, as applied to thin flat surfaces, the boundary conditions are to be ultimately satisfied by the velocity potentials at the projection of the wing onto a plane (the xy -plane) with respect to which all deflections are considered small and which lies parallel to the free-stream direction. Thickness effects are not taken into account; hence, the velocity potentials are associated only with conditions that yield lift and are consequently anti-symmetrical with respect to the plane of the projected wing. It is therefore necessary to consider the potentials at only one surface, upper or lower, of the projected wing. The upper surface is chosen for this analysis.

The differential equation for the propagation of small disturbances that must be satisfied by the velocity potentials is (when referred to a rectangular coordinate system x, y, z with the xy -plane coincident with the reference plane and moving uniformly in the negative x -direction, fig. 1)

$$\frac{1}{c^2} \left(\frac{\partial}{\partial t} + V \frac{\partial}{\partial x} \right)^2 \phi = \frac{\partial^2 \phi}{\partial x^2} + \frac{\partial^2 \phi}{\partial y^2} + \frac{\partial^2 \phi}{\partial z^2} \quad (1)$$

The boundary conditions that must be satisfied by the velocity potential are: (a) In regions T₁, T₂, T₃, and N the flow must be tangent to the surface of the wing or

$$\left(\frac{\partial \phi}{\partial z} \right)_{z \rightarrow 0} = w(x, y, t) = V \frac{\partial Z_m}{\partial x} + \frac{\partial Z_m}{\partial t} \quad (2)$$

where Z_m is the vertical displacement of the ordinates of the surface of any chordwise section of the wing (see fig. 1 (b)). (b) In regions T₁ and T₂ the pressure must fall to zero along the wing tips and remain zero in the portion of the Mach cones emanating from the foremost points of the wing tips not occupied by the wing. (Another condition, that the potential must be zero ahead of the wing and in the region off the wing adjacent to the Mach cones emanating from the foremost points of the tips, is automatically satisfied by the type of source and doublet synthesis employed in the solutions.)

For the particular case of a wing independently performing small sinusoidal torsional oscillations of amplitude $|\alpha_0|$ and frequency ω about some spanwise axis x_0 and small sinusoidal vertical translations of amplitude $|h_0|$ and frequency ω , the equation of Z_m is

$$Z_m = e^{i\omega t} [\alpha_0(x-x_0) + h_0] = \alpha(x-x_0) + h \quad (3)$$

Substituting this expression for Z_m into equation (2) gives

$$w(x, y, t) = V\alpha + \dot{\alpha}(x-x_0) + \dot{h} \quad (4)$$

The velocity potential may thus be expressed as the sum of separate effects due to position and motion of the wing associated with the individual terms in equation (4) as

$$\phi = \phi_\alpha + \phi_{\dot{\alpha}} + \phi_{\dot{h}} \quad (5)$$

DERIVATION OF ϕ_N

The boundary-value problem in the purely supersonic region (fig. 2 (a)) is the same as that for the two-dimensional wing treated in reference 4. This problem is there shown to be satisfied by a distribution of sources referred to, in this case, as moving sources because of the uniform motion; that is,

$$\phi_N(x, y, z, t) = -\frac{1}{2\beta\pi} \int_0^{x-\beta z} \int_{\tau_1}^{\tau_2} W(\xi, \eta) \phi_1 d\eta d\xi \quad (6)$$

In equation (6), $W(\xi, \eta)$ represents the space variation of source strength and must be evaluated in accordance with the individual terms of equation (4), and ϕ_1 is the potential of a moving source situated at the point $(\xi, \eta, 0)$ that may be expressed as

$$\phi_1 = \frac{w(t-\tau_1) + w(t-\tau_2)}{\sqrt{(\eta-\eta_1)(\eta_2-\eta)}} \quad (7)$$

where $w(t)$ is the time variation of source strength and the symbols with subscripts appearing in equation (7) are defined as

$$\tau_1 = \frac{M(x-\xi)}{c\beta^2} - \frac{\sqrt{(\eta-\eta_1)(\eta_2-\eta)}}{\beta c}$$

$$\tau_2 = \frac{M(x-\xi)}{c\beta^2} + \frac{\sqrt{(\eta-\eta_1)(\eta_2-\eta)}}{\beta c}$$

$$\eta_1 = y - \frac{1}{\beta} \sqrt{(x-\xi)^2 - \beta^2 z^2}$$

$$\eta_2 = y + \frac{1}{\beta} \sqrt{(x-\xi)^2 - \beta^2 z^2}$$

The time variation of source strength $w(t)$ for harmonic oscillations may be written as

$$w(t) = e^{i\omega t} \quad (8)$$

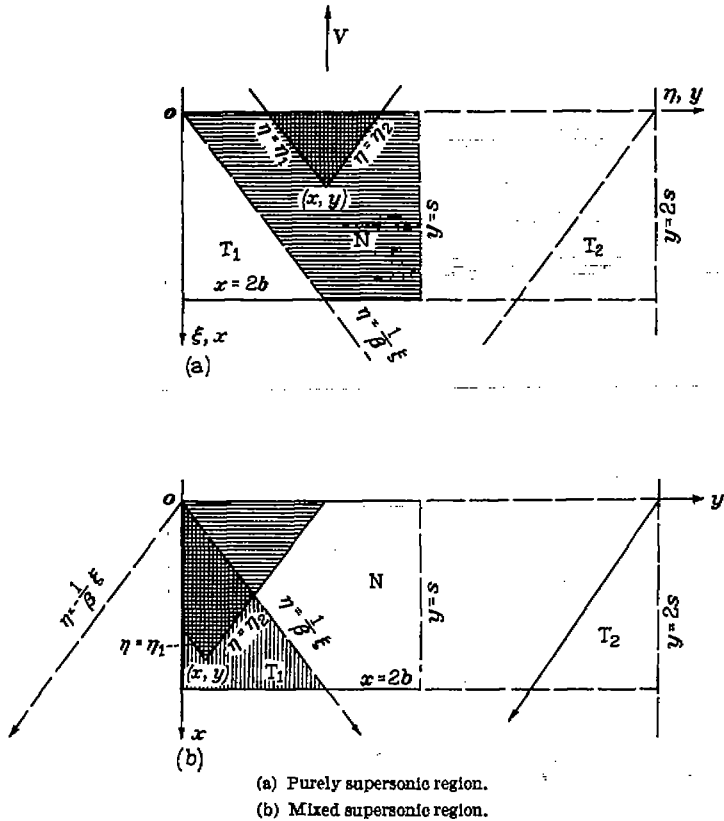

FIGURE 2.—Sketch illustrating areas of integration for purely supersonic and mixed supersonic regions of flow.

The numerator in equation (7) thus becomes

$$w(t - \tau_1) + w(t - \tau_2) = e^{i\omega(t - \tau_1)} + e^{i\omega(t - \tau_2)} \\ = 2e^{i\omega t} e^{-i\omega \frac{\tau_2 + \tau_1}{2}} \cos \omega \frac{\tau_2 - \tau_1}{2} \quad (9)$$

Substituting equations (7) and (9) into equation (6) yields

$$\phi_N(x, y, z, t) = -\frac{e^{i\omega t}}{\pi} \int_0^{x - \beta z} \int_{\eta_1}^{\eta_2} \frac{W(\xi, \eta) e^{-i\bar{\omega}(x - \xi)} \cos\left(\frac{\bar{\omega}}{M} R\right) d\eta d\xi}{R} \quad (10)$$

where, for brevity,

$$\bar{\omega} = \frac{\omega M}{c\beta^2} = \frac{M^2 \omega}{V^2 \beta^2}$$

and

$$R = \sqrt{(x - \xi)^2 - \beta^2(y - \eta)^2 - \beta^2 z^2} = \beta \sqrt{(\eta - \eta_1)(\eta_2 - \eta)}$$

The values of $W(\xi, \eta)$ associated with the different terms of equation (4) are

For \dot{h}

$$W(\xi, \eta) = \frac{iV\beta^2 \bar{\omega}}{M^2} h_0 \quad (11)$$

For $V\alpha$

$$W(\xi, \eta) = V\alpha_0 \quad (12)$$

For $\dot{\alpha}(x - x_0)$

$$W(\xi, \eta) = \frac{iV\beta^2 \bar{\omega}}{M^2} \alpha_0 (\xi - x_0) \quad (13)$$

If any of the values of $W(\xi, \eta)$ given in equations (11), (12), and (13) is put into equation (10), the integration with

respect to η can be readily performed and the remaining integral evaluated as a series of Bessel functions. (See, for example, reference 4.) However, in order to be consistent with and to lead naturally to a succeeding part of the analysis the integrand is expanded into a Maclaurin's series with respect to $\bar{\omega}$. The expansion yields

$$\phi_N(x, y, z, t) = -\frac{e^{i\omega t}}{\pi} \int_0^{x - \beta z} \int_{\eta_1}^{\eta_2} W(\xi, \eta) \left[\left(a_{01} \frac{1}{R} + a_{11} \frac{\xi}{R} + \dots \right. \right. \\ \left. \left. + a_{n1} \frac{\xi^n}{R} + \dots \right) + (a_{02} R + a_{12} \xi R + \dots \right. \\ \left. \left. + a_{n2} \xi^n R + \dots \right) + \dots + (a_{0m} R^{2m-3} + a_{1m} \xi R^{2m-3} \right. \\ \left. \left. + \dots + a_{nm} \xi^n R^{2m-3} + \dots \right) + \dots \right] d\eta d\xi \quad (14)$$

where the coefficients a_{nm} are functions of $\bar{\omega}$, x , and M ; those coefficients involving $\bar{\omega}$, up to and including the third power, are

$$\left. \begin{aligned} a_{01} &= 1 - i\bar{\omega}x - \frac{\bar{\omega}^2}{2} x^2 + \frac{i\bar{\omega}^3}{6} x^3 \\ a_{11} &= i\bar{\omega} + \bar{\omega}^2 x - \frac{i\bar{\omega}^3}{2} x^2 \\ a_{21} &= -\frac{\bar{\omega}^2}{2} + \frac{i\bar{\omega}^3}{2} x \\ a_{31} &= -\frac{i\bar{\omega}^3}{6} \\ a_{02} &= -\frac{\bar{\omega}^2}{2M^2} + \frac{i\bar{\omega}^3}{2M^2} x \\ a_{12} &= -\frac{i\bar{\omega}^3}{2M^2} \end{aligned} \right\} \quad (15)$$

Observe the following identity that is valid regardless of the highest power of $\bar{\omega}$ considered and that will be of subsequent use, namely

$$a_{01} + x a_{11} + \dots + x^n a_{n1} = 1 \quad (16)$$

It will be noted in equation (14) that the potential of a moving source when expanded in terms of the frequency appears as a series of terms similar to steady-state source potentials plus series of terms involving various powers of R . By grouping the terms in equation (14) with respect to powers of ξ , the following form of the source potential convenient for later use is obtained:

$$\phi_N(x, y, z, t) = -\frac{e^{i\omega t}}{\pi} \int_0^{x - \beta z} \int_{\eta_1}^{\eta_2} W(\xi, \eta) \left[\left(a_{01} \frac{1}{R} + a_{02} R + \dots \right. \right. \\ \left. \left. + a_{0m} R^{2m-3} + \dots \right) + \xi \left(a_{11} \frac{1}{R} + a_{12} R + \dots \right. \right. \\ \left. \left. + a_{1m} R^{2m-3} + \dots \right) + \dots + \xi^n \left(a_{n1} \frac{1}{R} + a_{n2} R \right. \right. \\ \left. \left. + \dots + a_{nm} R^{2m-3} + \dots \right) + \dots \right] d\eta d\xi \quad (17)$$

With the terms of the series grouped in this manner, in view of the fact that the differential equation (1) is independent

of ξ , it is apparent that the coefficient of each power of ξ in equation (17) is a solution to the differential equation.

If the values of $W(\xi, \eta)$ in equations (11), (12), and (13) are put into either equation (14) or equation (17), the integrations of each term can be easily carried out in closed form. Moreover it can readily be shown that, when all the terms involving $\bar{\omega}$ up to a given power are taken into account, the differential equation (1) is satisfied to the highest power of $\bar{\omega}$ considered. The boundary condition of tangential flow as expressed in equation (4) is satisfied exactly and does not depend on the order of $\bar{\omega}$ considered.

Putting the values of $W(\xi, \eta)$ in equations (11), (12), and (13) successively into either equation (14) or equation (17), carrying out the indicated integration, and setting $z=0$ yields for the velocity potential, to the third power of $\bar{\omega}$ at the upper surface of the wing, in the purely supersonic region:

$$\phi_N = -\frac{1}{\beta} (\dot{h} f_1 + V \alpha f_2 + \dot{\alpha} f_3) \quad (18)$$

where

$$\left. \begin{aligned} f_1 &= x - \frac{i\bar{\omega}}{2} x^2 - \frac{\bar{\omega}^2}{12M^2} (2\beta^2 + 3)x^3 \\ f_2 &= x - \frac{i\bar{\omega}}{2} x^2 - \frac{\bar{\omega}^2}{12M^2} (2\beta^2 + 3)x^3 + \frac{i\bar{\omega}^3}{48M^2} (2\beta^2 + 5)x^4 \\ f_3 &= \frac{x}{2}(x - 2x_0) - \frac{i\bar{\omega}x^2}{6}(x - 3x_0) - \frac{\bar{\omega}^2}{48M^2} (2\beta^2 + 3)x^3(x - 4x_0) \end{aligned} \right\} \quad (19)$$

DERIVATION OF ϕ_{x_1} , ϕ_{x_2} , AND ϕ_{x_3} †

In order to satisfy the boundary-value problem in regions of mixed supersonic flow it is convenient to start with the potential of a moving doublet. Then, for a given order of the frequency of oscillation, this potential, as will be shown in the following analysis, can be modified so that when integrated over the appropriate region the results will satisfy, as in the purely supersonic case, the differential equation to the given order of the frequency and will satisfy the condition of tangential flow exactly. The potential of the type of doublet required may be obtained by partial differentiation of the potential of a moving source (see integrand of equation (17)) with respect to the direction normal to the plane of the wing, namely

$$\begin{aligned} \phi_2 &= \frac{e^{i\omega t}}{\pi} \frac{\partial}{\partial z} \left[\left(a_{01} \frac{1}{R} + a_{02} R + \dots + a_{0m} R^{2m-3} + \dots \right) + \right. \\ &\quad \xi \left(a_{11} \frac{1}{R} + a_{12} R + \dots + a_{1m} R^{2m-3} + \dots \right) + \\ &\quad \left. \dots + \xi^n \left(a_{n1} \frac{1}{R} + a_{n2} R + \dots + a_{nm} R^{2m-3} + \dots \right) + \dots \right] \quad (20) \end{aligned}$$

Examination of equation (20), like equation (17), shows that the coefficient of each power of ξ satisfies the differential equation and, since the differential equation is linear, it is permissible in synthesizing the solution to the boundary-

†Although the derivation of these potentials in NACA TN 2064 led to correct results, the procedure followed therein is based on erroneous arguments. The present procedure is correct and general.

value problem to weight these coefficients separately. Furthermore the coefficient of each power of ξ consists of a term that has the form of a steady-state doublet potential, namely

$$a_{n1} \frac{\partial}{\partial z} \left(\frac{1}{R} \right) \quad (21)$$

plus a series of other terms involving various powers of R . In the following analysis, attention is first directed to the treatment of the first term of the coefficient ξ^n , (expression (21)). The other terms will be treated subsequently.

Expression (21) has the form that in steady flow is convenient for treating the (antisymmetric) problem of satisfying the condition of tangential flow for a distribution of normal velocity prescribed, at the wing surface, independent of y but proportional to x^n ; that is, a weight or distribution function $D_n(\xi, \eta)$ can be determined so that

$$\lim_{z \rightarrow 0} \frac{\partial^2}{\partial z^2} \int_r \int D_n(\xi, \eta) \frac{\xi^n}{R} d\xi d\eta = \pi x^n \quad n=(0,1,2,\dots) \quad (22)$$

where the region of integration r is the portion of the wing situated in the fore cone emanating from the field point (x, y, z) (shown in fig. 2(b) for the rectangular wing with $z=0$).

The distribution function D_n for rectangular wings may be easily determined when D_0 , the distribution function for this wing at constant angle of attack in steady supersonic flow, is known. The expression for D_0 is derived in reference 1 and found to be

$$D_0 = \frac{2}{\beta} \left[\sqrt{\beta\eta(\xi - \beta\eta)} + \xi \sin^{-1} \sqrt{\frac{\beta\eta}{\xi}} \right] \quad (23)$$

From this expression and equation (22) it follows by direct substitution and reduction that

$$D_n = n! \int_0^\xi \int_0^\xi \dots \int_0^\xi D_0(\xi, \eta) (d\xi)^n = n \int_0^\xi (\xi - \lambda)^{n-1} D_0(\lambda, \eta) d\lambda \quad (24)$$

With D_n known so that equation (22) is satisfied it may be demonstrated, with use of identity (16), that these "doublet-type" terms alone satisfy the condition of tangential flow. For example, let it be required to satisfy this condition for vertical translations; then,

$$\begin{aligned} w(x, t) &= \frac{\dot{h}}{\pi} \frac{\partial^2}{\partial z^2} \int_r \int \sum_{m=0}^n \left[a_{m1} D_m(\xi, \eta) \frac{\xi^m}{R} \right] d\xi d\eta \\ &= \dot{h} (a_{01} + x a_{11} + \dots + x^n a_{n1}) = \dot{h} \end{aligned}$$

The next step in the analysis is to consider terms of the type

$$\frac{\partial}{\partial z} (a_{nm} R^{2m-3}) \quad m > 1 \quad (25)$$

appearing in the coefficients of ξ^n (equation (20)). It is to be noted that, when the power of $\bar{\omega}$ to which the potential is to be derived is chosen, the number of terms in equation (20) that are to be treated is determined by the expressions a_{mn} that contain $\bar{\omega}$ to the chosen order (see equations (15) for $\bar{\omega}$ to the third power).

If the distribution function D_n (equation (24)) is introduced into equation (20) and the resulting equation is integrated over the appropriate region of the rectangle (fig. 2(b)), it is found that in the limit as $z \rightarrow 0$ terms of the type given in expression (25) do not contribute to the resulting potential, but they do contribute to the resulting vertical velocity. Therefore, since it has been shown that the doublet-type terms, taken alone, satisfy the condition of tangential flow, the distribution of vertical velocity would now contain extraneous terms that need to be canceled. This canceling may be achieved by what is essentially an iterative process: the functions D_n (equation (24)) are used with terms in equation (20) that have the form given in expression (25) to calculate the velocity that is to be canceled; then, terms involving $1/R$ that may be individually weighted and which, of course, must satisfy the differential equation to the order of $\bar{\omega}$ to which the velocity potential is to be derived are added to equation (20); finally, by making use of equation (22), weight or distribution functions for these additional terms may be determined so as to cancel the extraneous velocity.

This process is illustrated for ω to the third power as follows:

$$\begin{aligned} \phi_{T_1} = & -\lim_{z \rightarrow 0} \frac{e^{i\omega t}}{\pi} \frac{\partial}{\partial z} \iint_{\tau} W(\xi, \eta) \left[D_0 \left(a_{01} \frac{1}{R} + a_{02} R \right) + \right. \\ & D_1 \xi \left(a_{11} \frac{1}{R} + a_{12} R \right) + D_2 a_{21} \frac{\xi^2}{R} + D_3 a_{31} \frac{\xi^3}{R} + \\ & \left. a_{02} (\xi D_1 - D_2) \frac{\xi^2}{R} + a_{12} \left(\frac{\xi D_2 - D_3}{2} \right) \frac{\xi^2}{R} \right] d\xi d\eta \quad (26) \end{aligned}$$

where it is noted in the integrand that two extra terms have been added to equation (20) to accomplish the desired canceling. Substituting the values of $W(\xi, \eta)$ defined in equations (11), (12), and (13) into equation (26) gives the expression for the velocity potential at the upper surface of the wing

$$\begin{aligned} \phi_{T_1} = & -\frac{1}{\beta\pi} \left(h \left[2F_1 - \left(2i\bar{\omega} + \frac{\bar{\omega}^2 x}{M^2} \right) F_2 - \frac{\beta^2 \bar{\omega}^2}{M^2} F_3 \right] + \right. \\ & V \alpha \left[2F_1 - \left(2i\bar{\omega} + \frac{\bar{\omega}^2}{M^2} x - \frac{i\bar{\omega}^3}{2M^2} x^2 \right) F_2 - \right. \\ & \left. \frac{\beta^2 \bar{\omega}^2}{M^2} F_3 + \frac{i\bar{\omega}^3}{6M^2} (2\beta^2 - 1) F_4 \right] + \alpha \left\{ 2(x - x_0) F_1 - \right. \\ & \left[2 + 2i\bar{\omega}(x - x_0) + \frac{\bar{\omega}^2}{2M^2} (x^2 - 2xx_0) \right] F_2 + \\ & \left. \left[2i\bar{\omega} - \frac{\beta^2 \bar{\omega}^2}{M^2} (x - x_0) \right] F_3 + \frac{\bar{\omega}^2}{2M^2} (2\beta^2 + 1) F_4 \right\} \quad (27) \end{aligned}$$

where the terms are grouped conveniently by the definition of F_n in the following integral:

$$F_n = \int_0^x x^{n-1} \sin^{-1} \sqrt{\frac{\beta y}{x}} dx \quad (n=1, 2, 3, 4) \quad (28)$$

(The functions F_n , given in equation (28), and certain related functions are of particular importance in the remainder of this development. Integrated values of this function for the first few values of n and expressions for related functions needed later in this analysis are given in the appendix.)

Examination of equation (27) shows that along the Mach line $x = \beta y$, separating region T_1 from region N , the expression ϕ_{T_1} reduces to the expression for ϕ_N given in equation (18).

The corresponding potentials for regions T_2 and T_3 can now be obtained. The potential ϕ_{T_2} is obtained from equation (27) by merely substituting $2s - y$ for y in equation (28) so that

$$G_n = \int_0^x x^{n-1} \sin^{-1} \sqrt{\frac{\beta(2s-y)}{x}} dx \quad (n=1, 2, 3, 4) \quad (29)$$

The potential in region T_3 (that is for $1 \leq A\beta < 2$) is a simple superposition of the potentials for regions N , T_1 , and T_2 , as in the steady case (see, for example, reference 5), and may be written as

$$\phi_{T_3} = \phi_{T_1} + \phi_{T_2} - \phi_N \quad (30)$$

FORCES AND MOMENTS

Two types of force and moment coefficients are derived. First, in order to gain some insight into the over-all effect of aspect ratio on the forces and moments, expressions for total force and moment coefficients are derived. Then, in order to present expressions that are more suitable for use in flutter calculations, expressions for section force and moment coefficients for any station along the span are derived.

Total forces and moments.—The local pressure difference between the upper and lower surfaces on the wing may be written

$$\Delta p = -2\rho \left(\frac{\partial \phi}{\partial t} + V \frac{\partial \phi}{\partial x} \right) \quad (31)$$

In order to derive expressions for total forces and total moments, it is only necessary to consider the velocity potential in two regions—either regions N and T_1 or regions N and T_2 . Therefore the expression for the total force, positive downward, on the wing may be written as

$$\bar{P} = -2 \int_N \int \Delta p_N dy dx - 2 \int_{T_1} \int \Delta p_{T_1} dy dx \quad (32)$$

where Δp_N is to be calculated from equation (18) and the integrations in the first term are to be extended over the shaded portion of region N shown in figure 2 (a), and where Δp_{T_1} is to be calculated from equation (27) and the integrations in the second term are to be extended over region T_1 . (The integrations in the first term are simple and may be performed by inspection. Those in the second term may be readily performed by making use of the relations given in the appendix.)

After the indicated integrations have been performed and all position coordinates involved have been referred to the chord $2b$ (but the original coordinate symbols maintained), the results can be written as

$$\bar{P} = -8\rho b^2 V^2 k^2 A e^{i\omega t} \left[\frac{h_0}{b} (\bar{L}_1 + i\bar{L}_2) + \alpha_0 (\bar{L}_3 + i\bar{L}_4) \right] \quad (33)$$

where the reduced frequency k is related to ω and $\bar{\omega}$ by the relations

$$k = \frac{b\omega}{V} = \frac{b\beta^2}{M^2} \bar{\omega} \quad (34)$$

and where

$$\bar{L}_1 = \frac{1}{3\beta^4} \left(3\beta - \frac{2+\beta^2}{A} \right) \quad (35a)$$

$$\bar{L}_2 = \frac{1}{\beta k} - \frac{M^2 k}{\beta^5} - \frac{1}{2A} \left[\frac{1}{\beta^2 k} - \frac{M^2 k}{3\beta^6} (4 + \beta^2) \right] \quad (35b)$$

$$\bar{L}_3 = \frac{1}{\beta k^2} - \frac{1}{3\beta^6} (3 + \beta^2 + 6\beta^2 x_0) - \frac{1}{2A} \left\{ \frac{1}{\beta^2 k^2} - \frac{1}{3\beta^6} [(3\beta^2 + 4) + 4\beta^2 x_0 (2 + \beta^2)] \right\} \quad (35c)$$

$$\bar{L}_4 = \frac{1}{\beta^3 k} (\beta^2 - 1 - 2\beta^2 x_0) + \frac{M^2 k}{6\beta^7} (5 + \beta^2 + 12\beta^2 x_0) + \frac{1}{3A} \left[\frac{1}{\beta^4 k} (2 + 3\beta^2 x_0) - \frac{M^2 k}{5\beta^8} (8 + 4\beta^2 + 20\beta^2 x_0 + 5\beta^4 x_0) \right] \quad (35d)$$

The quantities \bar{L}_i ($i=1, 2, 3, 4$) are the in-phase and out-of-phase components of the total force coefficients, \bar{L}_1 and \bar{L}_3 being the in-phase and \bar{L}_2 and \bar{L}_4 being the out-of-phase components. It will be noted that \bar{L}_1 and \bar{L}_2 are associated only with vertical translations of the wing and are independent of axis-of-rotation location x_0 . The components \bar{L}_3 and \bar{L}_4 are associated with angular position and rotation of the wing about any axis $x=x_0$ and depend partly on the location of x_0 .

The total moment, positive clockwise, on the wing about the arbitrary axis of rotation $x=x_0$ is

$$\bar{M}_x = -2 \int_N \int (x-x_0) \Delta p_N dy dx - 2 \int_{T_1} \int (x-x_0) \Delta p_{T_1} dy dx \quad (36)$$

If steps similar to those required to obtain equation (33) are performed, there is obtained

$$\bar{M}_x = -8\rho b^3 V^2 k^2 A e^{i\omega t} \left[\frac{h_0}{b} (\bar{M}_1 + i\bar{M}_2) + \alpha_0 (\bar{M}_3 + i\bar{M}_4) \right] \quad (37)$$

where

$$\bar{M}_1 = \frac{2}{3\beta^3} (2 - 3x_0) - \frac{1}{6A\beta^4} [3\beta^2 + 1 - 4x_0(2 + \beta^2)] \quad (38a)$$

$$\bar{M}_2 = \frac{1}{\beta k} (1 - 2x_0) - \frac{M^2 k}{2\beta^5} (3 - 4x_0) - \frac{1}{3A} \left\{ \frac{1}{\beta^2 k} (2 - 3x_0) - \frac{M^2 k}{5\beta^6} [4(\beta^2 + 4)(4 - 5x_0)] \right\} \quad (38b)$$

$$\bar{M}_3 = \frac{1}{\beta k^2} (1 - 2x_0) - \frac{1}{2\beta^6} [3 + \beta^2 + 4x_0(\beta^2 - 1) - 8\beta^2 x_0^2] - \frac{1}{3A} \left\{ \frac{1}{\beta^2 k^2} (2 - 3x_0) - \frac{1}{5\beta^6} [4(4 + 3\beta^2) + 5x_0(3\beta^4 + 3\beta^2 - 4) - 20\beta^2 x_0^2 (\beta^2 + 2)] \right\} \quad (38c)$$

$$\bar{M}_4 = \frac{2}{3\beta^3 k} [2(\beta^2 - 1) - 3x_0(2\beta^2 - 1) + 6\beta^2 x_0^2] + \frac{M^2 k}{15\beta^7} (20 + 4\beta^2 - 25x_0 + 40\beta^2 x_0 - 60\beta^2 x_0^2) + \frac{1}{3A} \left\{ \frac{1}{\beta^4 k} [3 + 4x_0(\beta^2 - 1) - 6\beta^2 x_0^2] - \frac{M^2 k}{15\beta^8} [20(2 + \beta^2) - 24x_0(2 - 3\beta^2 - \beta^4) - 30\beta^2 x_0^2 (4 + \beta^2)] \right\} \quad (38d)$$

The quantities \bar{M}_1 and \bar{M}_2 are, respectively, the in-phase and out-of-phase components of total moment coefficients about the axis $x=x_0$ associated with vertical translations of the wing; \bar{M}_3 and \bar{M}_4 are the corresponding components due to angular position and rotation of the wing about $x=x_0$.

It is of interest to note in equations (35) and (38) that the components \bar{L}_1 and \bar{M}_1 do not involve the reduced frequency k . The effect of frequency on these two components comes from terms involving the frequency to the fourth and higher powers; but for values of k thought likely to be encountered in supersonic flutter ($k < 0.1$), the contribution of these higher-power terms to any of the components in equations (35) and (38) is, for the most part, negligible.

Section forces and moments.—The section forces and moments at any spanwise station are derived by integrating the pressure difference along the chord for the forces and the pressure difference multiplied by a moment arm for the moments. Since the distribution over the entire wing is symmetrical with regard to the midspan section, it is only necessary to derive expressions for the forces and moments at any station of the half-span adjacent to the origin. (See figs. 1, 2, and 3.)

Under the restrictions previously stipulated, two cases that can arise are considered (see fig. 3): (1) the Mach lines from the tips do not intersect on the wing (or $A\beta > 2$), and (2) the Mach lines intersect on the wing but the Mach line from one tip does not intersect the opposite tip ahead of the trailing edge (or $1 \leq A\beta \leq 2$). Only the final forms of the section force and moment equations are given. These forms are easily calculated by deriving the pressure difference for the different regions from the appropriate velocity potential, making use of figure 3 to determine the limits of

integration for the regions involved, and using the relations given in the appendix to carry out the more troublesome integrations. The integrated expression for any region can then be reduced to the forms

$$P = -4\rho b^2 V^2 k^2 e^{i\omega t} \left[\frac{h_0}{b} (L_1 + iL_2) + \alpha_0 (L_3 + iL_4) \right] \quad (39)$$

and

$$M_\alpha = -4\rho b^2 V^2 k^2 e^{i\omega t} \left[\frac{h_0}{b} (M_1 + iM_2) + \alpha_0 (M_3 + iM_4) \right] \quad (40)$$

where the position coordinates are referred to the chord length $2b$.

The components of force and moment coefficients for the half-span adjacent to the origin are as follows:

Case 1 (see fig. 3(a)): For any section between the tip and the point where the Mach line intersects the trailing edge, or where $0 < y < \frac{1}{\beta}$, the components of section force coefficients are

$$L_1 = -\frac{4}{\beta\pi} \left(\bar{F}_1 - \frac{1+2\beta^2}{\beta^2} \bar{F}_2 \right) \quad (41a)$$

$$L_2 = \frac{4}{\beta\pi} \left\{ \frac{1}{2k} \bar{F}_1 + \frac{M^2 k}{\beta^4} [(2\beta^2 - 1)\bar{F}_2 - 3\beta^2 \bar{F}_3] \right\} \quad (41b)$$

$$L_3 = \frac{4}{\beta\pi} \left[\frac{1}{2k^2} \bar{F}_1 - (1-2x_0)\bar{F}_2 + \frac{6\beta^4 + 3\beta^2 - 1}{\beta^4} \bar{F}_2 - \frac{2(2\beta^2 + 1)x_0}{\beta^2} \bar{F}_2 - \frac{6\beta^2 + 5}{\beta^2} \bar{F}_3 \right] \quad (41c)$$

$$L_4 = \frac{4}{\beta\pi} \left\{ \frac{1}{k} \left[(2-x_0)\bar{F}_1 - \frac{3\beta^2 + 1}{\beta^2} \bar{F}_2 \right] + \frac{M^2 k}{3\beta^6} [3(1-\beta^2 + 2\beta^4 + 2\beta^2 x_0 - 4\beta^4 x_0)\bar{F}_2 - 6\beta^4(4-3x_0)\bar{F}_3 - (1-7\beta^2 - 20\beta^4)\bar{F}_4] \right\} \quad (41d)$$

where \bar{F}_n ($n=1, 2, 3, 4$), given in the appendix, is obtained from F_n (equation (28)) when $x=2b$. For any section between the point where the Mach line intersects the trailing edge and the midspan, or where $\frac{1}{\beta} \leq y \leq \frac{A}{2}$, the components of section forces are:

$$\left. \begin{aligned} L_1 &= \frac{1}{\beta^3} \\ L_2 &= \frac{1}{\beta k} - \frac{M^2 k}{\beta^5} \\ L_3 &= \frac{1}{\beta k^2} - \frac{1}{3\beta^5} [(3+\beta^2) + 6\beta^2 x_0] \\ L_4 &= \frac{1}{\beta^3 k} [(\beta^2 - 1) - 2\beta^2 x_0] + \frac{M^2 k}{6\beta^7} (5 + \beta^2 + 12\beta^2 x_0) \end{aligned} \right\} \quad (42)$$

As a check on the results in equations (41) and (42) the expressions in equations (41) reduce to those in equations (42) when $y = \frac{1}{\beta}$.

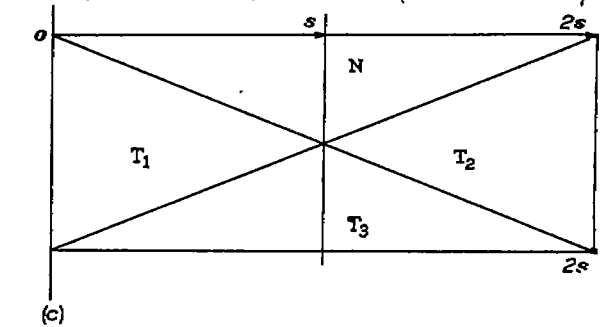
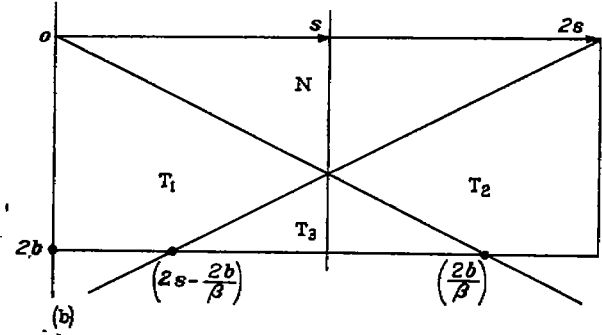
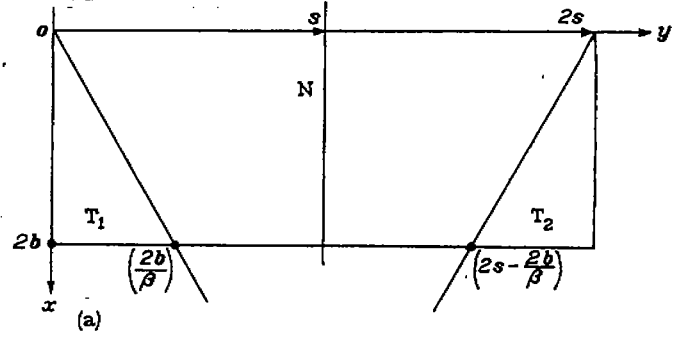

(a) Mach lines from tips do not intersect on wing.

(b) Mach lines from tips intersect on wing but Mach line from one tip does not intersect opposite tip.

(c) Mach lines from tips intersect on wing and Mach line from one tip intersects opposite tip at trailing edge.

FIGURE 3.—Sketch illustrating different Mach line locations accounted for in analysis.

The components of section moment coefficients for case 1 are as follows:

For $0 < y < \frac{1}{\beta}$,

$$M_1 = -\frac{4}{\beta\pi} \left[(1-2x_0)\bar{F}_1 + 2x_0 \frac{2\beta^2 + 1}{\beta^2} \bar{F}_2 - \frac{3\beta^2 + 2}{\beta^2} \bar{F}_3 \right] \quad (43a)$$

$$M_2 = \frac{4}{\beta\pi} \left\{ \frac{1}{k} (\bar{F}_2 - x_0 \bar{F}_1) + \frac{M^2 k}{\beta^2} \left[\frac{(2\beta^2 - 1)(1-2x_0)}{\beta^2} \bar{F}_2 + 6x_0 \bar{F}_3 - \frac{4\beta^2 + 1}{\beta^2} \bar{F}_4 \right] \right\} \quad (43b)$$

$$M_3 = \frac{4}{\beta\pi} \left[\frac{1}{k^2} (\bar{F}_2 - x_0 \bar{F}_1) - \frac{4(1-3x_0+3x_0^2)}{3} \bar{F}_1 + \frac{(6\beta^4+3\beta^2-1)(1-2x_0)+4\beta^2x_0^2(1+2\beta^2)}{\beta^4} \bar{F}_2 + \frac{6(1+\beta^2)}{\beta^2} x_0 \bar{F}_3 - \frac{20\beta^4+21\beta^2+3}{3\beta^4} \bar{F}_4 \right] \quad (43c)$$

$$M_4 = \frac{4}{\beta\pi} \left(\frac{2}{k} \left[(1-x_0)^2 \bar{F}_1 + \frac{2\beta^2+1}{\beta^2} x_0 \bar{F}_2 - \frac{2\beta^2+1}{\beta^2} \bar{F}_2 \right] + \frac{4M^2k}{\beta^2} \left\{ \frac{1}{6\beta^4} [(4\beta^4-2\beta^2+1)(1-3x_0+3x_0^2)+1-3x_0^2] \bar{F}_2 - (2-4x_0+3x_0^2) \bar{F}_3 - \frac{x_0}{6\beta^4} (8\beta^4+4\beta^2-1) \bar{F}_4 + \frac{1}{3\beta^2} (5\beta^2+3) \bar{F}_5 \right\} \right) \quad (43d)$$

and for $\frac{1}{\beta} \leq y \leq \frac{A}{2}$,

$$\left. \begin{aligned} M_1 &= \frac{2}{3\beta^3} (2-3x_0) \\ M_2 &= \frac{1}{\beta k} (1-2x_0) - \frac{M^2k}{2\beta^5} (3-4x_0) \\ M_3 &= \frac{1}{\beta k^2} (1-2x_0) - \frac{1}{2\beta^5} (3+\beta^2-4x_0+4\beta^2x_0-8\beta^2x_0^2) \\ M_4 &= \frac{2}{3\beta^3k} [2(\beta^2-1)-3x_0(2\beta^2-1)+6\beta^2x_0^2] + \frac{M^2k}{15\beta^7} [4(5+\beta^2)+5x_0(8\beta^2-5)-60\beta^2x_0^2] \end{aligned} \right\} \quad (44)$$

The expressions in equations (43) reduce to those in equations (44) when $y = \frac{1}{\beta}$. The expressions in equations (42) and (44) correspond to the more exact two-dimensional components of force and moment coefficients derived in reference 4. For values of $k < 0.1$ these expressions yield, for the most part, values that are in good agreement with those that may be calculated from the tables in reference 4.

Case 2 (see fig. 3 (b)): For any section between the tip at $y=0$ and the point where the Mach line from the tip at $y=2s$ intersects the trailing edge (or where $0 < y \leq A - \frac{1}{\beta}$), the components of section force coefficients are given by equations (41) and the components of section moment coefficients, by equation (43). For any section between the point where the Mach line from the tip at $y=2s$ intersects the trailing edge and the midspan (or where $A - \frac{1}{\beta} < y \leq \frac{A}{2}$), the components of section force coefficients are

$$L_1 = - \left\{ \frac{4}{\beta\pi} \left[(\bar{F}_1 + \bar{G}_1) - \frac{1+2\beta^2}{\beta^2} (\bar{F}_2 + \bar{G}_2) \right] + \frac{1}{\beta^3} \right\} \quad (45a)$$

$$L_2 = \frac{4}{\beta\pi} \left\{ \frac{1}{2k} (\bar{F}_1 + \bar{G}_1) + \frac{M^2k}{\beta^4} [(2\beta^2-1)(\bar{F}_2 + \bar{G}_2) - 3\beta^2(\bar{F}_3 + \bar{G}_3)] - \left(\frac{1}{\beta k} - \frac{M^2k}{\beta^5} \right) \right\} \quad (45b)$$

$$L_3 = \frac{4}{\beta\pi} \left[\frac{1}{2k^2} (\bar{F}_1 + \bar{G}_1) - 2(1-2x_0)(\bar{F}_1 + \bar{G}_1) + \frac{6\beta^4+3\beta^2-1}{\beta^4} (\bar{F}_2 + \bar{G}_2) - \frac{2(2\beta^2+1)x_0}{\beta^2} (\bar{F}_2 + \bar{G}_2) - \frac{6\beta^2+5}{\beta^2} (\bar{F}_3 + \bar{G}_3) \right] - \left\{ \frac{1}{\beta k^2} - \frac{1}{3\beta^5} [(3+\beta^2)+6\beta^2x_0] \right\} \quad (45c)$$

$$L_4 = \frac{4}{\beta\pi} \left\{ \frac{1}{k} \left[(2-x_0)(\bar{F}_1 + \bar{G}_1) - \frac{3\beta^2+1}{\beta^2} (\bar{F}_2 + \bar{G}_2) \right] + \frac{M^2k}{3\beta^6} [3(1-\beta^2+2\beta^4+2\beta^2x_0-4\beta^4x_0)(\bar{F}_2 + \bar{G}_2) - 6\beta^4(4-3x_0)(\bar{F}_3 + \bar{G}_3) - (1-7\beta^2-20\beta^4)(\bar{F}_4 + \bar{G}_4)] \right\} - \left\{ \frac{1}{\beta^3k} [(\beta^2-1)-2\beta^2x_0] + \frac{M^2k}{6\beta^7} (5+\beta^2+12\beta^2x_0) \right\} \quad (45d)$$

where \bar{G}_n ($n=1, 2, 3, 4$), given in the appendix, is obtained from G_n (equation (29)) when $x=2b$. The corresponding components of section moment coefficients are

$$M_1 = - \left\{ \frac{4}{\beta\pi} \left[(1-2x_0)(\bar{F}_1 + \bar{G}_1) + \frac{2x_0(2\beta^2+1)}{\beta^2} (\bar{F}_2 + \bar{G}_2) \right] - \frac{3\beta^2+1}{\beta^2} (\bar{F}_3 + \bar{G}_3) + \frac{2}{3\beta^3} (2-3x_0) \right\} \quad (46a)$$

$$M_2 = \frac{4}{\beta\pi} \left\{ \frac{1}{k} [(\bar{F}_2 + \bar{G}_2) - x_0(\bar{F}_1 + \bar{G}_1)] + \frac{M^2k}{\beta^2} \left[\frac{(2\beta^2-1)(1-2x_0)}{\beta^2} (\bar{F}_2 + \bar{G}_2) + 6x_0(\bar{F}_3 + \bar{G}_3) - \frac{4\beta^2+1}{\beta^2} (\bar{F}_4 + \bar{G}_4) \right] \right\} - \left[\frac{1}{\beta k} (1-2x_0) - \frac{M^2k}{2\beta^5} (3-4x_0) \right] \quad (46b)$$

$$M_3 = \frac{4}{\beta\pi} \left\{ \frac{1}{k^2} [(\bar{F}_2 + \bar{G}_2) - x_0(\bar{F}_1 + \bar{G}_1)] - 4 \frac{1-3x_0+3x_0^2}{3} (\bar{F}_1 + \bar{G}_1) + \frac{(6\beta^4+3\beta^2-1)(1-2x_0)+4\beta^2x_0^2(1+2\beta^2)}{\beta^4} (\bar{F}_2 + \bar{G}_2) + \frac{6x_0(1+\beta^2)}{\beta^2} (\bar{F}_3 + \bar{G}_3) - \frac{20\beta^4+21\beta^2+3}{3\beta^4} (\bar{F}_4 + \bar{G}_4) \right\} - \left\{ \frac{1}{\beta k^2} (1-2x_0) - \frac{1}{2\beta^5} [(3+\beta^2)-4x_0(1-\beta^2)-8\beta^2x_0^2] \right\} \quad (46c)$$

$$M_4 = \frac{4}{\beta\pi} \left(\frac{2}{k} \left[(1-x_0)^2 (\bar{F}_1 + \bar{G}_1) + \frac{2\beta^2+1}{\beta^2} x_0 (\bar{F}_2 + \bar{G}_2) - \frac{2\beta^2+1}{\beta^2} (\bar{F}_3 + \bar{G}_3) \right] + \frac{4M^2k}{\beta^2} \left\{ \frac{1}{6\beta^4} [(4\beta^4-2\beta^2+1)(1-3x_0+3x_0^2)+1-3x_0^2] (\bar{F}_2 + \bar{G}_2) - (2-4x_0+3x_0^2) (\bar{F}_3 + \bar{G}_3) - \frac{x_0}{6\beta^4} (8\beta^4+4\beta^2-1) (\bar{F}_4 + \bar{G}_4) + \frac{1}{3\beta^2} (5\beta^2+3) (\bar{F}_5 + \bar{G}_5) \right\} \right) - \left\{ \frac{2}{3\beta^3k} [2(\beta^2-1)-3x_0(2\beta^2-1)+6\beta^2x_0^2] + \frac{M^2k}{15\beta^7} [4(5+\beta^2)+5x_0(8\beta^2-5)-60\beta^2x_0^2] \right\} \quad (46d)$$

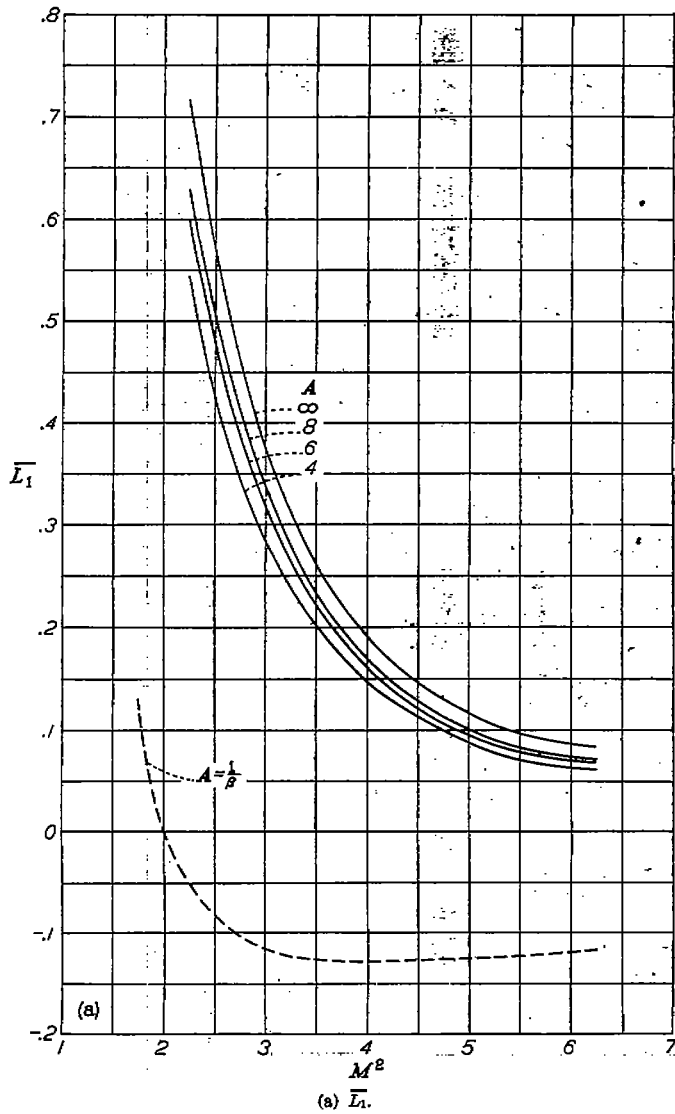

FIGURE 4.—Components of total force coefficients as functions of M^2 for $x_0=0.4$, $k=0.02$, and various values of A .

For the limiting condition of case 2—that is, when the Mach line from one tip intersects the opposite tip at the trailing edge, or $A = \frac{1}{\beta}$ (see fig. 3(c))—the components of section force coefficients are given by equations (45) and the corresponding components of moment coefficients, by equations (46).

SOME PARTICULAR CALCULATIONS AND DISCUSSIONS

From the expressions for total force and moment coefficients (equations (35) and (38), respectively) the over-all effect of aspect ratio on the magnitude of the forces and moments can be calculated for particular values of the parameters M , k , x_0 , and A . Examination of these equations shows that varying some of the parameters might cause some terms in the equations to vanish and to change sign. For example, if x_0 is continuously increased from some value less than $1/2$ to some value greater than $1/2$, the first terms in the expressions for \bar{M}_2 and \bar{M}_3 vanish at $x_0 = \frac{1}{2}$ and

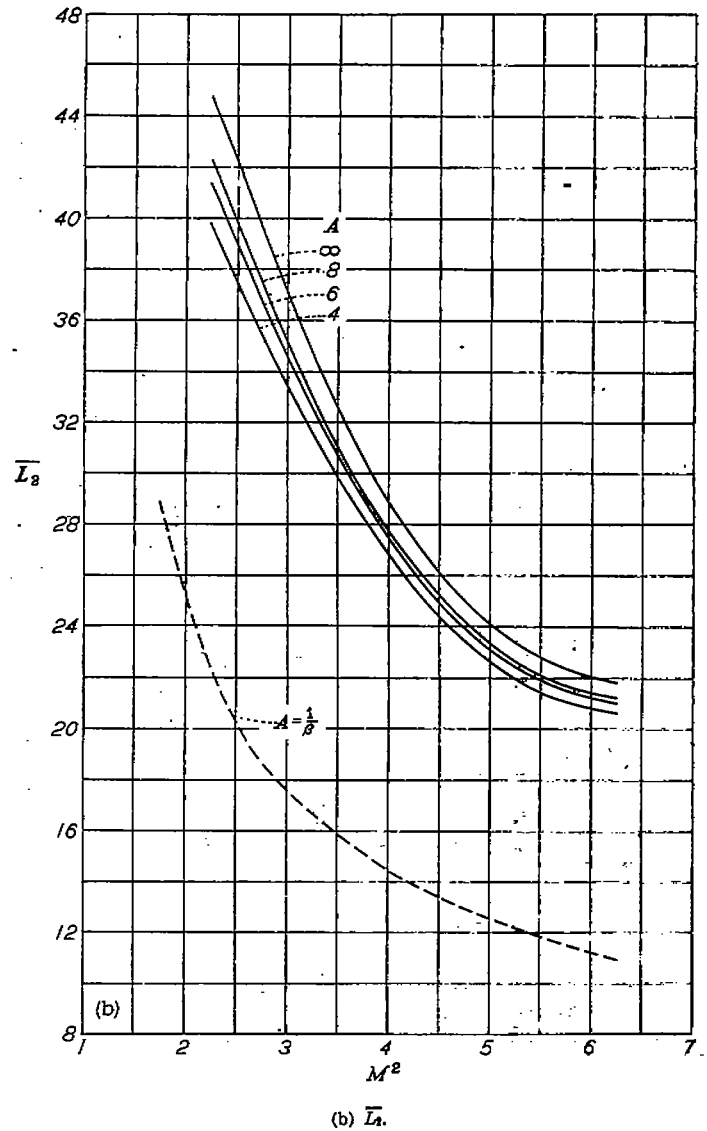

FIGURE 4.—Continued.

change sign when x_0 becomes greater than $1/2$. In particular, decreasing the aspect ratio decreases the components of force and moment coefficients \bar{L}_1 , \bar{L}_2 , \bar{L}_3 , \bar{M}_1 , \bar{M}_2 , and \bar{M}_3 but increases the two important components \bar{L}_4 and \bar{M}_4 .

Although the effect of aspect ratio may change considerably with only a small change in any one (or more) of the parameters M , k , and x_0 , some insight into what the over-all effect might be can be gained from calculations of all the components of total force and moment coefficients for various values of M and A and fixed values of the parameters k and x_0 . Results of such a set of calculations are presented in figures 4 to 7.

In figures 4 and 5 the components of total force and moment coefficients for various values of A and for $x_0=0.4$ and $k=0.02$ are plotted as functions of M^2 . The curves in these figures calculated for infinite aspect ratio correspond to the two-dimensional results of reference 4. The dashed curves represent calculations for aspect ratio and Mach number combinations that cause the Mach lines from one tip to intersect the opposite tip at the trailing edge so that

(c) \bar{L}_s .

FIGURE 4.—Continued.

along the dashed curves the aspect ratio is not constant but varies with M^2 according to the previously given expression

$$A = \frac{1}{\beta} = \frac{1}{\sqrt{M^2 - 1}}$$

The difference, at any value of M^2 , between the dashed curves and the curves corresponding to infinite aspect ratio in figures 4 and 5 is, therefore, for the chosen values of k and x_0 , the maximum effect of aspect ratio on the components of total force and moment coefficients for a rectangular wing under the restrictions of the foregoing analysis. It will be noted in figures 4 and 5 that, when the aspect ratio is small, the deviation of the three-dimensional results from two-dimensional results may be quite large.

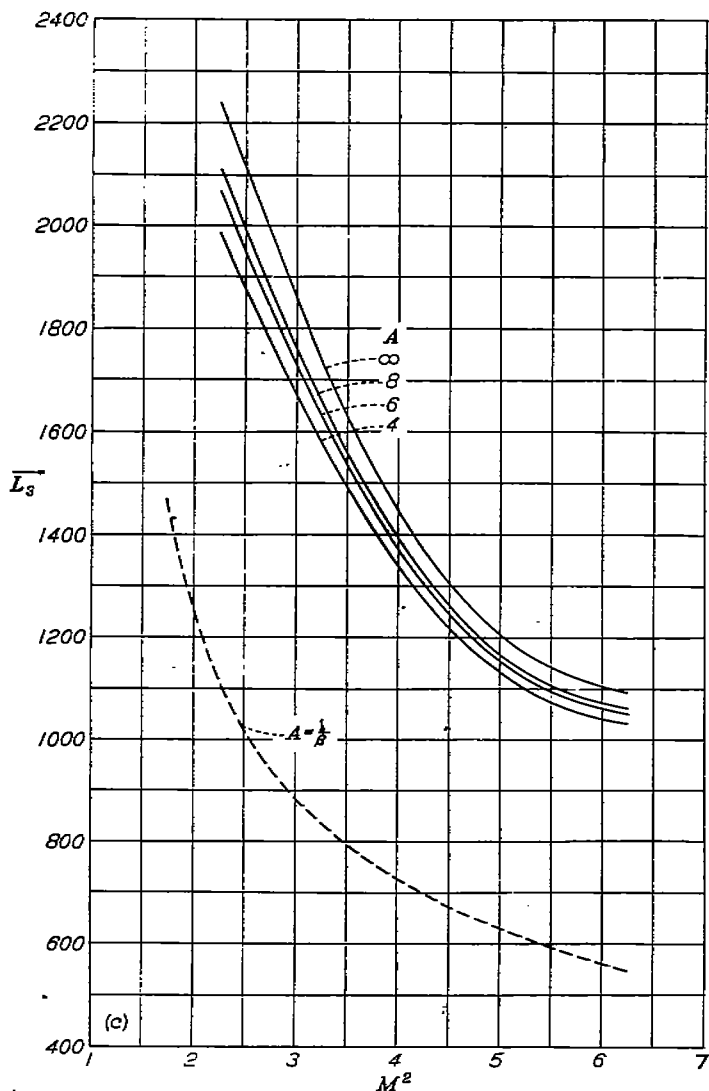
In figures 6 and 7 the components of the total force and moment coefficients are plotted as functions of aspect ratio for $x_0=0.4$, $k=0.02$, and some particular values of M . It will be noted in these figures that all the components of force and moment coefficients undergo rapid changes with

(d) \bar{L}_4 .

FIGURE 4.—Concluded.

respect to varying aspect ratio when A becomes less than 4 or 5. It may be remarked that the directions of the changes with respect to aspect ratio appear to be such that they would have favorable effects on the flutter characteristics of a wing.

The spanwise distribution of the components of section force and moment coefficients computed from equations (41) to (44) for $A=4$, $x_0=0.4$, $k=0.02$, and $M=2$ are plotted in figures 8 and 9. The portions of the curves in these figures corresponding to values of y in the range $\frac{1}{\beta} \leq y \leq A - \frac{1}{\beta}$ are the two-dimensional values, and the effect of aspect ratio may be noted in the tip regions, $0 \leq y \leq \frac{1}{\beta}$ and $A - \frac{1}{\beta} \leq y \leq A$, as deviations from these two-dimensional values.

In conclusion, it may be stated that, in regard to the effect of aspect ratio on supersonic flutter, an important item that has not been discussed herein but can be studied for any particular case with the aid of equations (33) and (36) is the change in center of pressure, associated with prescribed motions of the wing, with change in aspect ratio. An investigation to find the effect that thickness might have on the center-of-pressure location is also needed. An extension of the foregoing analysis to include the effect of an aileron as an additional degree of freedom would follow in a straightforward manner.

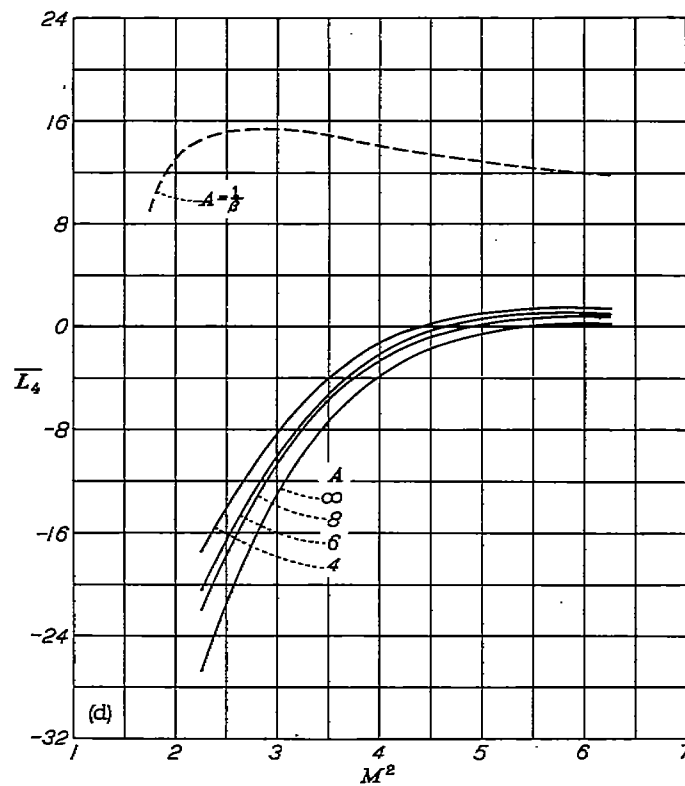
LANGLEY AERONAUTICAL LABORATORY,
NATIONAL ADVISORY COMMITTEE FOR AERONAUTICS,
LANGLEY FIELD, VA., January 6, 1950.

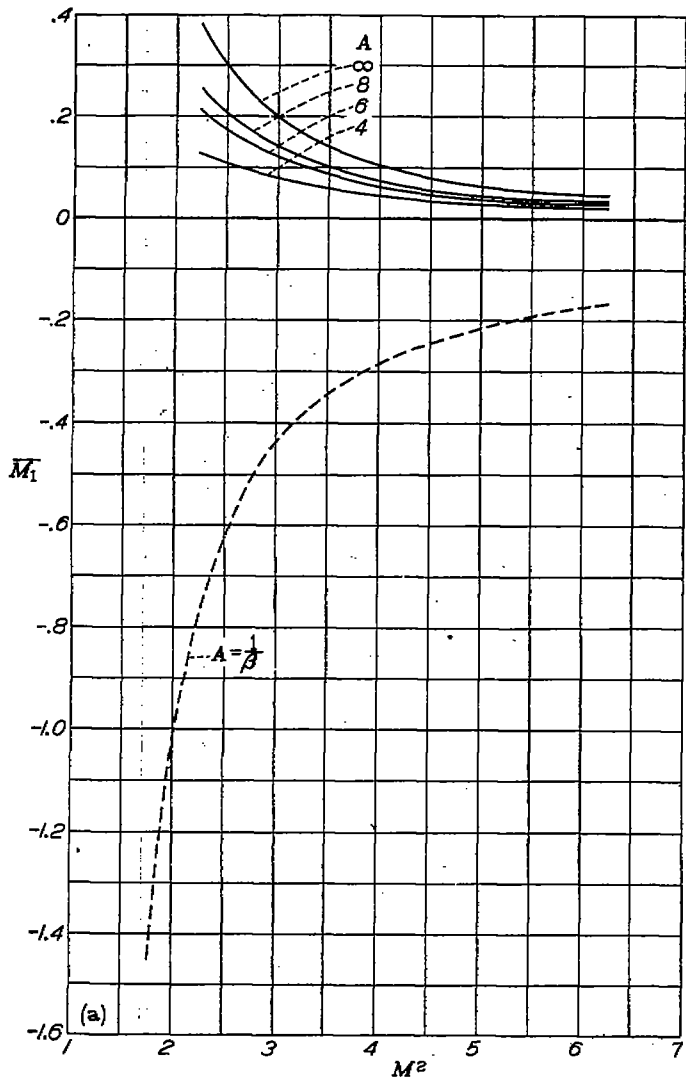

(a) \bar{M}_1 .

FIGURE 5.—Components of total moment coefficients as functions of M^2 for $r_2=0.4$, $k=0.02$, and various values of A .

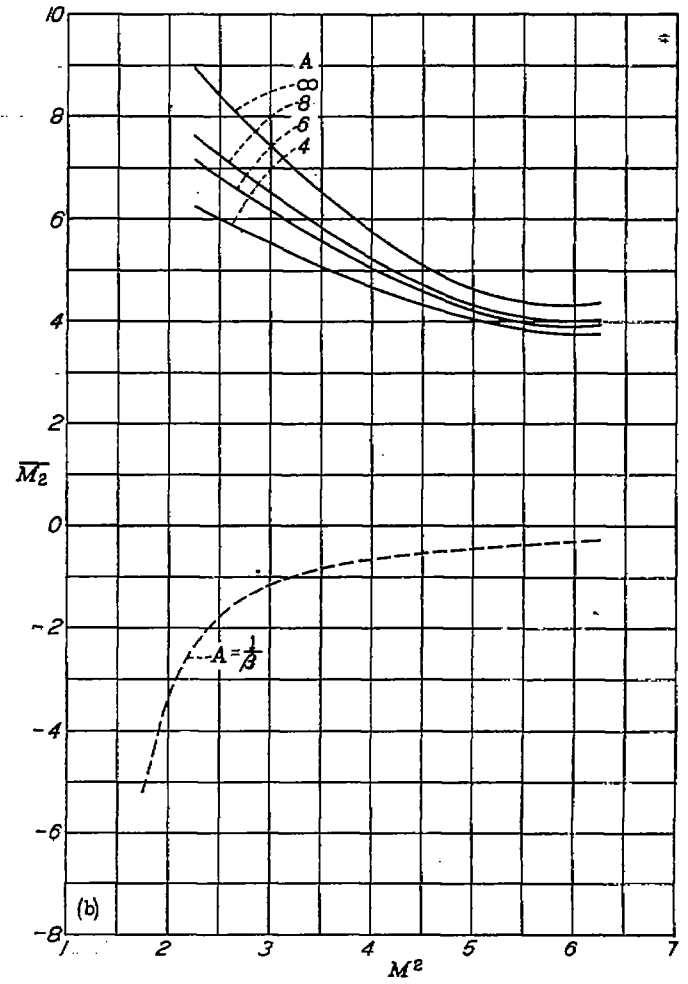

(b) \bar{M}_2 .

FIGURE 5.—Continued.

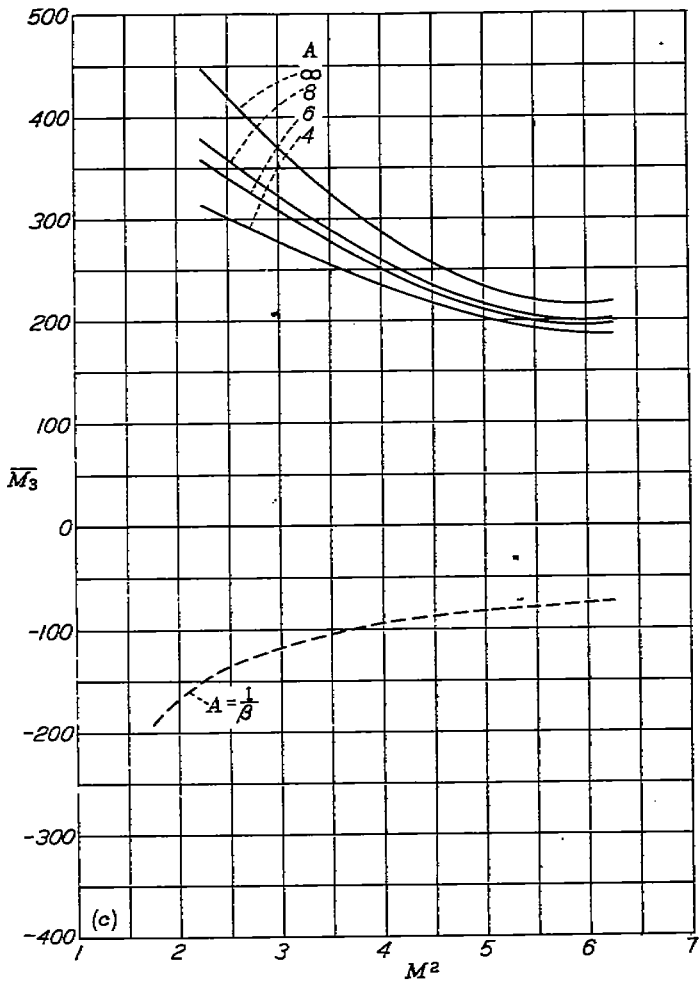

FIGURE 5.—Continued.

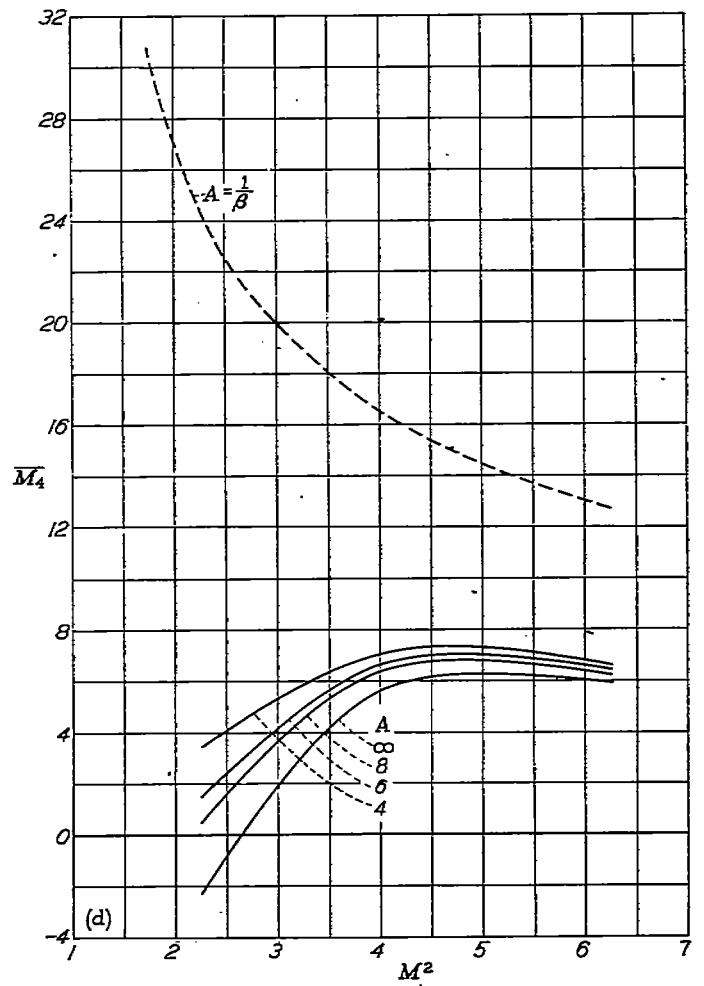

FIGURE 5.—Concluded.

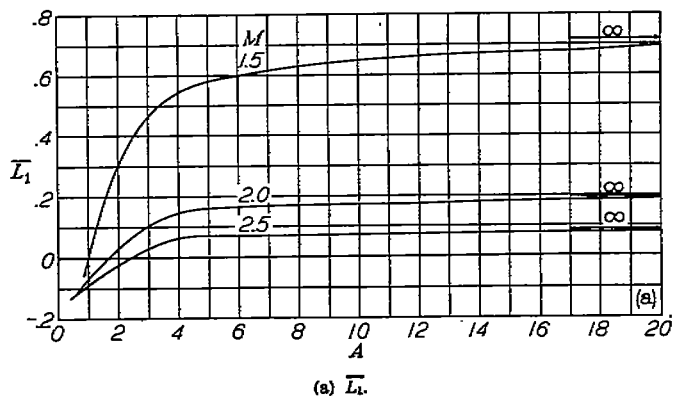

FIGURE 6.—Components of total force coefficients as functions of A for $r_0=0.4$, $k=0.02$, and various values of M .

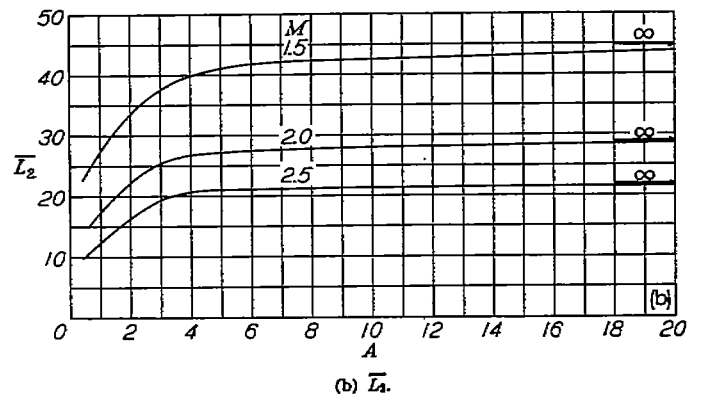
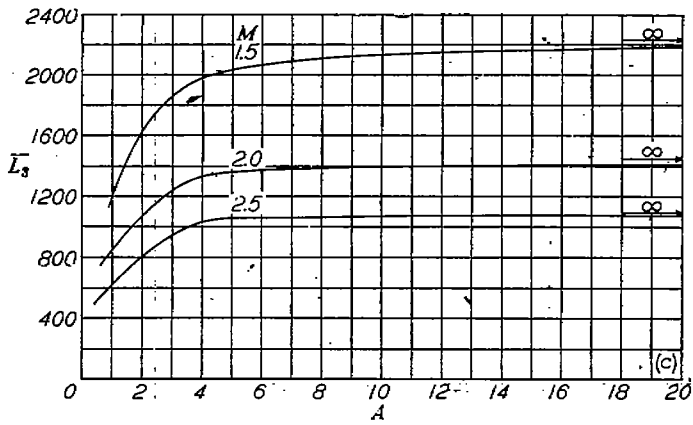
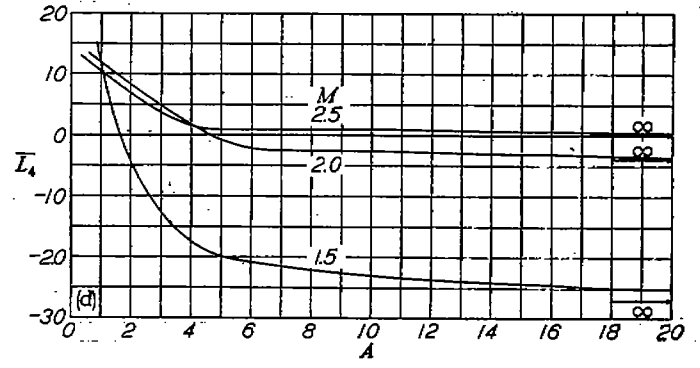

FIGURE 6.—Continued.



(c) \bar{L}_3 .
FIGURE 6.—Continued.



(d) \bar{L}_4 .
FIGURE 6.—Concluded.

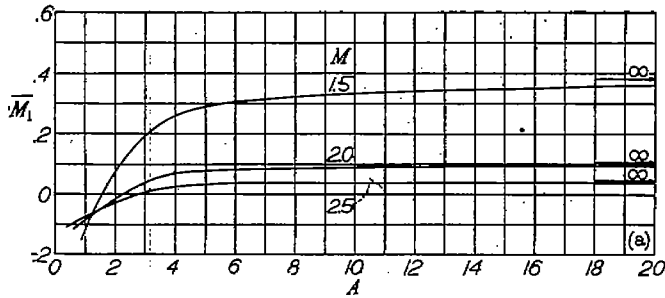

(a) \bar{M}_1 .

FIGURE 7.—Components of total moment coefficients as functions of A for $x_0=0.4$, $\delta=0.02$, and various values of M .

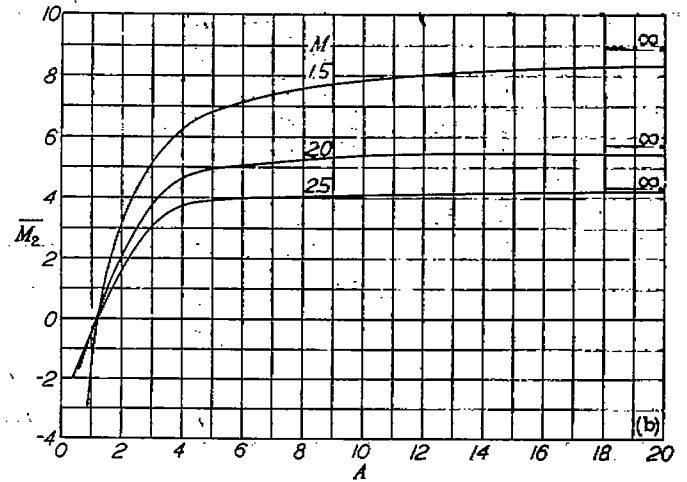

(b) \bar{M}_2 .

FIGURE 7.—Continued.

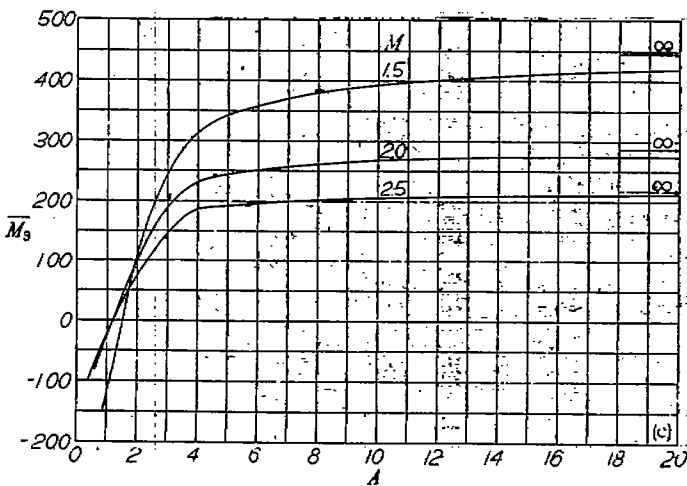

(c) \bar{M}_3 .

FIGURE 7.—Continued.

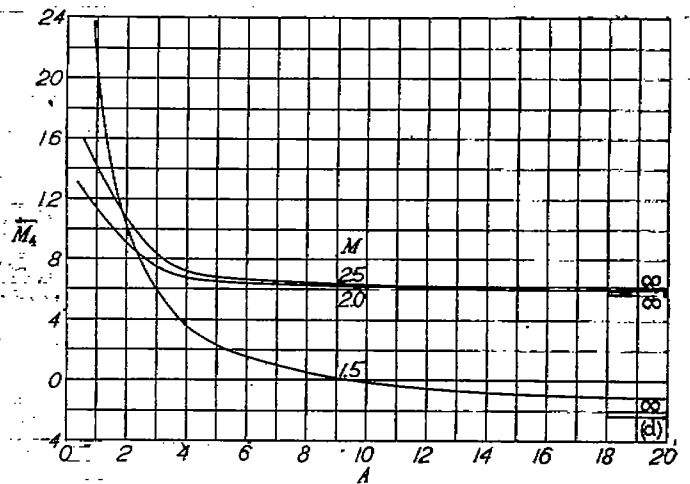

(d) \bar{M}_4 .

FIGURE 7.—Concluded.

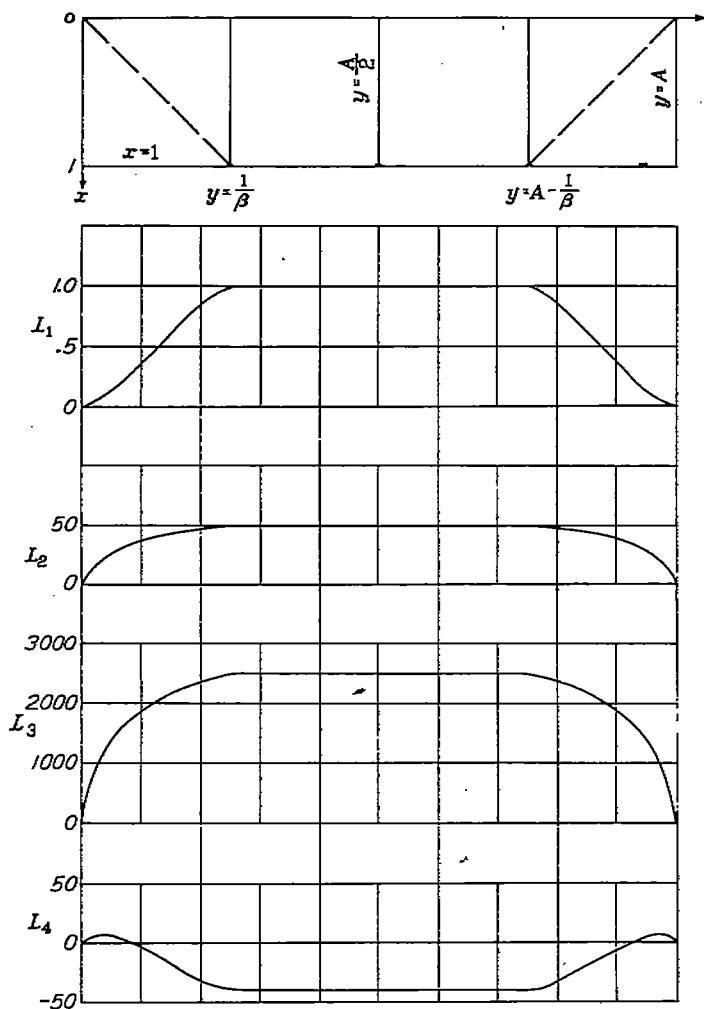

FIGURE 8.—Spanwise distribution of components of section force coefficients for $\alpha=0.4$, $k=0.02$, $M=2$, and $A=4$.

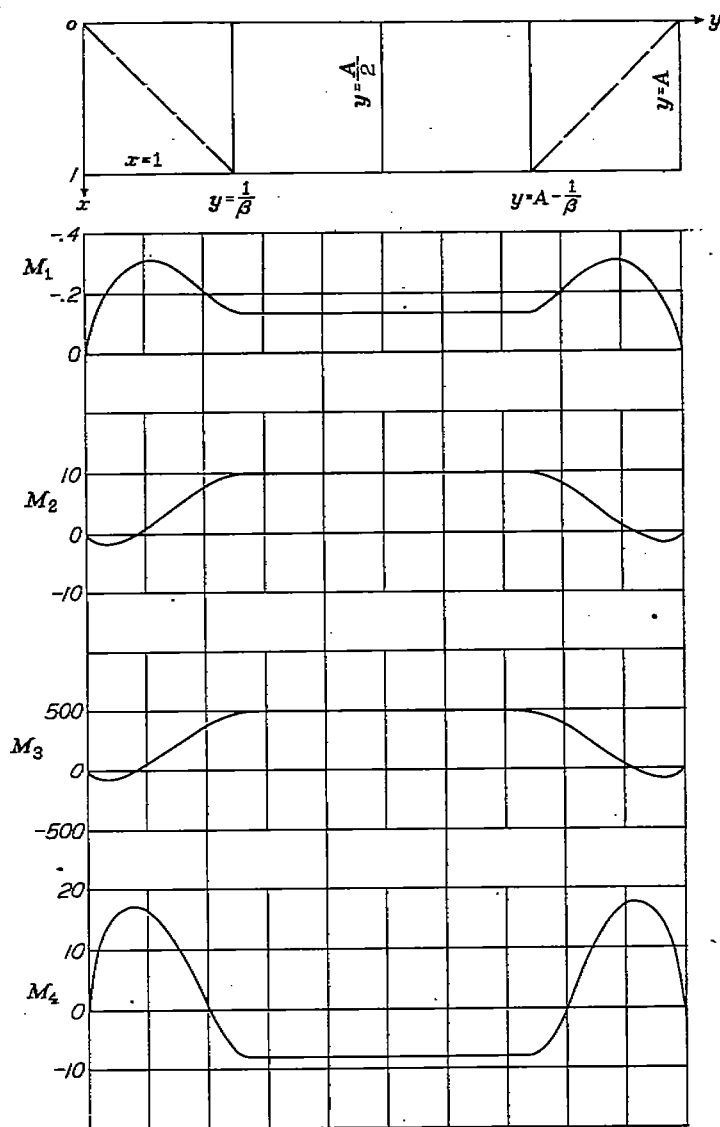

FIGURE 9.—Spanwise distribution of components of section moment coefficients for $\alpha=0.4$, $k=0.02$, $M=2$, and $A=4$.

APPENDIX

SOME INTEGRATED VALUES OF $F_n, G_n, \bar{F}_n, \bar{G}_n$, AND OTHER RELATED FUNCTIONS

Values of F_n and G_n .—The values of the functions F_n (equation (28)) and G_n (equation (29)) for the first few values of n are as follows:

$$F_n = \int_0^x x^{n-1} \sin^{-1} \sqrt{\beta y/x} dx \quad (n=1, 2, 3, \dots)$$

$$F_1 = \sqrt{\beta y(x-\beta y)} + x \sin^{-1} \sqrt{\beta y/x}$$

$$F_2 = \frac{x+2\beta y}{6} \sqrt{\beta y(x-\beta y)} + \frac{x^2}{2} \sin^{-1} \sqrt{\beta y/x}$$

$$F_3 = \frac{3x^2+4\beta yx+8\beta^2 y^2}{45} \sqrt{\beta y(x-\beta y)} + \frac{x^3}{3} \sin^{-1} \sqrt{\beta y/x}$$

$$F_4 = \frac{5x^3+6\beta yx^2+8\beta^2 y^2x+16\beta^3 y^3}{140} \sqrt{\beta y(x-\beta y)} + \frac{x^4}{4} \sin^{-1} \sqrt{\beta y/x}$$

$$F_5 = \frac{35x^4+40\beta yx^3+48\beta^2 y^2x^2+64\beta^3 y^3x+128\beta^4 y^4}{1575} \sqrt{\beta y(x-\beta y)} + \frac{x^5}{5} \sin^{-1} \sqrt{\beta y/x}$$

$$G_n = \int_0^x x^{n-1} \sin^{-1} \sqrt{\frac{\beta(2s-y)}{x}} dx \quad (n=1, 2, 3, \dots)$$

$$G_1 = \sqrt{\beta(2s-y)[x-\beta(2s-y)]} + x \sin^{-1} \sqrt{\frac{\beta(2s-y)}{x}}$$

$$G_2 = \frac{x+2\beta(2s-y)}{6} \sqrt{\beta(2s-y)[x-\beta(2s-y)]} + \frac{x^2}{2} \sin^{-1} \sqrt{\frac{\beta(2s-y)}{x}}$$

$$G_3 = \frac{3x^2+4\beta x(2s-y)+8\beta^2(2s-y)^2}{45} \sqrt{\beta(2s-y)[x-\beta(2s-y)]} + \frac{x^3}{3} \sin^{-1} \sqrt{\frac{\beta(2s-y)}{x}}$$

$$G_4 = \frac{5x^3+6x^2\beta(2s-y)+8x\beta^2(2s-y)^2+16\beta^3(2s-y)^3}{140} \sqrt{\beta(2s-y)[x-\beta(2s-y)]} + \frac{x^4}{4} \sin^{-1} \sqrt{\frac{\beta(2s-y)}{x}}$$

$$G_5 = \frac{35x^4+40x^3\beta(2s-y)+48x^2\beta^2(2s-y)^2+64x\beta^3(2s-y)^3+128\beta^4(2s-y)^4}{1575} \sqrt{\beta(2s-y)[x-\beta(2s-y)]} + \frac{x^5}{5} \sin^{-1} \sqrt{\frac{\beta(2s-y)}{x}}$$

Values of \bar{F}_n and \bar{G}_n .—The following expressions define the functions \bar{F}_n and \bar{G}_n appearing in equations (41), (43), (45), and (46) in the body of the report. In these expressions the variable y has been referred to the chord $2b$; that is $y/2b$ has been replaced by y and in the expressions for \bar{G}_n the ratio s/b has been replaced by A :

$$\bar{F}_1 = \sqrt{\beta y(1-\beta y)} + \sin^{-1} \sqrt{\beta y}$$

$$\bar{F}_2 = \frac{1+2\beta y}{6} \sqrt{\beta y(1-\beta y)} + \frac{1}{2} \sin^{-1} \sqrt{\beta y}$$

$$\bar{F}_3 = \frac{3+4\beta y+8\beta^2 y^2}{45} \sqrt{\beta y(1-\beta y)} + \frac{1}{3} \sin^{-1} \sqrt{\beta y}$$

$$\bar{F}_4 = \frac{5+6\beta y+8\beta^2 y^2+16\beta^3 y^3}{140} \sqrt{\beta y(1-\beta y)} + \frac{1}{4} \sin^{-1} \sqrt{\beta y}$$

$$\bar{F}_5 = \frac{35+40\beta y+48\beta^2 y^2+64\beta^3 y^3+128\beta^4 y^4}{1575} \sqrt{\beta y(1-\beta y)} + \frac{1}{5} \sin^{-1} \sqrt{\beta y}$$

$$\bar{G}_1 = \sqrt{\beta(A-y)[1-\beta(A-y)]} + \sin^{-1} \sqrt{\beta(A-y)}$$

$$\bar{G}_2 = \frac{1+2\beta(A-y)}{6} \sqrt{\beta(A-y)[1-\beta(A-y)]} + \frac{1}{2} \sin^{-1} \sqrt{\beta(A-y)}$$

$$\bar{G}_3 = \frac{3+4\beta(A-y)+8\beta^2(A-y)^2}{45} \sqrt{\beta(A-y)[1-\beta(A-y)]} + \frac{1}{3} \sin^{-1} \sqrt{\beta(A-y)}$$

$$\bar{G}_4 = \frac{5+6\beta(A-y)+8\beta^2(A-y)^2+16\beta^3(A-y)^3}{140} \sqrt{\beta(A-y)[1-\beta(A-y)]} + \frac{1}{4} \sin^{-1} \sqrt{\beta(A-y)}$$

$$\bar{G}_5 = \frac{35+40\beta(A-y)+48\beta^2(A-y)^2+64\beta^3(A-y)^3+128\beta^4(A-y)^4}{1575} \sqrt{\beta(A-y)[1-\beta(A-y)]} + \frac{1}{5} \sin^{-1} \sqrt{\beta(A-y)}$$

Some integral relations for F_n and G_n .—Some pertinent integral relations for F_n are as follows:

$$\int_0^x F_n dx = xF_n - F_{n+1}$$

$$\int_0^x xF_n dx = \frac{1}{2}(x^2F_n - F_{n+2})$$

$$\int_0^x x^2F_n dx = \frac{1}{3}(x^3F_n - F_{n+3})$$

$$\int_0^x (x-x_0)F_n dx = \frac{x^2-2xx_0}{2}F_n + x_0F_{n+1} - \frac{1}{2}F_{n+2}$$

$$\int_0^x (x-x_0)^2F_n dx = \frac{x^3-3x_0x^2+3x_0^2x}{3}F_n - x_0^2F_{n+1} + x_0F_{n+2} - \frac{1}{3}F_{n+3}$$

Corresponding integral relations for G_n may be obtained from these relations by simply replacing F by G .

Integral relations for \bar{F}_n .—Integral relations for \bar{F}_n that may be used in calculating total forces and moments from sectional forces and moments are as follows:

$$2b \int_0^{1/\beta} \bar{F}_1 dy = \frac{3b\pi}{4\beta}$$

$$2b \int_0^{1/\beta} \bar{F}_2 dy = \frac{b\pi}{3\beta}$$

$$2b \int_0^{1/\beta} \bar{F}_3 dy = \frac{5b\pi}{24\beta}$$

$$2b \int_0^{1/\beta} \bar{F}_4 dy = \frac{3b\pi}{20\beta}$$

$$2b \int_0^{1/\beta} \bar{F}_5 dy = \frac{7b\pi}{60\beta}$$

REFERENCES

1. Watkins, Charles E.: Effect of Aspect Ratio on Undamped Torsional Oscillations of a Thin Rectangular Wing in Supersonic Flow. NACA TN 1895, 1949.
2. Garrick, I. E., and Rubinow, S. I.: Theoretical Study of Air Forces on an Oscillating or Steady Thin Wing in a Supersonic Main Stream. NACA Rep. 872, 1947.
3. Miles, John W.: The Oscillating Rectangular Airfoil at Supersonic Speeds. TM RRB-15, U. S. Naval Ordnance Test Station, Inyokern, Calif., June 1, 1949.
4. Garrick, I. E., and Rubinow, S. I.: Flutter and Oscillating Air-Force Calculations for an Airfoil in a Two-Dimensional Supersonic Flow. NACA Rep. 846, 1946.
5. Snow, R. M., and Bonney, E. A.: Aerodynamic Characteristics of Wings at Supersonic Speeds. Bumblebee Rep. No. 55, The Johns Hopkins Univ., Appl. Phys. Lab., March 1947.