

# NATIONAL ADVISORY COMMITTEE FOR AERONAUTICS

REPORT 1304

## FLIGHT INVESTIGATION OF THE EFFECTIVENESS OF AN AUTOMATIC AILERON TRIM CONTROL DEVICE FOR PERSONAL AIRPLANES

By WILLIAM H. PHILLIPS, HELMUT A. KUEHNEL,  
and JAMES B. WHITTEN



1957



---

---

**REPORT 1304**

---

**FLIGHT INVESTIGATION OF THE EFFECTIVENESS  
OF AN AUTOMATIC AILERON TRIM CONTROL  
DEVICE FOR PERSONAL AIRPLANES**

By **WILLIAM H. PHILLIPS, HELMUT A. KUEHNEL,**  
and **JAMES B. WHITTEN**

Langley Aeronautical Laboratory  
Langley Field, Va.

---

---

# National Advisory Committee for Aeronautics

*Headquarters, 1512 H Street NW., Washington 25, D. C.*

Created by Act of Congress approved March 3, 1915, for the supervision and direction of the scientific study of the problems of flight (U. S. Code, title 50, sec. 151). Its membership was increased from 12 to 15 by act approved March 2, 1929, and to 17 by act approved May 25, 1948. The members are appointed by the President and serve as such without compensation.

JAMES H. DOOLITTLE, Sc. D., Shell Oil Company, *Chairman*

LEONARD CARMICHAEL, Ph. D., Secretary, Smithsonian Institution, *Vice Chairman*

ALLEN V. ASTIN, Ph. D., Director, National Bureau of Standards.  
PRESTON R. BASSETT, M. A., Vice President, Sperry Rand Corp.  
DETLEV W. BRONK, Ph. D., President, Rockefeller Institute for Medical Research.  
FREDERICK C. CRAWFORD, Sc. D., Chairman of the Board, Thompson Products, Inc.  
WILLIAM V. DAVIS, JR., Vice Admiral, United States Navy, Deputy Chief of Naval Operations (Air).  
JEROME C. HUNSAKER, Sc. D., Massachusetts Institute of Technology.  
CHARLES J. MCCARTHY, S. B., Chairman of the Board, Chance Vought Aircraft, Inc.

CARL J. PFINGSTAG, Rear Admiral, United States Navy, Assistant Chief for Field Activities, Bureau of Aeronautics.  
DONALD L. PUTT, Lieutenant General, United States Air Force, Deputy Chief of Staff, Development.  
JAMES T. PYLE, A. B., Administrator of Civil Aeronautics.  
FRANCIS W. REICHELDERFER, Sc. D., Chief, United States Weather Bureau.  
EDWARD V. RICKENBACKER, Sc. D., Chairman of the Board, Eastern Air Lines, Inc.  
LOUIS S. ROTHSCHILD, Ph. B., Under Secretary of Commerce for Transportation.  
NATHAN F. TWINING, General, United States Air Force, Chief of Staff.

---

HUGH L. DRYDEN, PH. D., *Director*

JOHN F. VICTORY, LL. D., *Executive Secretary*

JOHN W. CROWLEY, JR., B. S., *Associate Director for Research*

EDWARD H. CHAMBERLIN, *Executive Officer*

---

HENRY J. E. REID, D. Eng., Director, Langley Aeronautical Laboratory, Langley Field, Va.  
SMITH J. DEFRANCE, D. Eng., Director, Ames Aeronautical Laboratory, Moffett Field, Calif.  
EDWARD R. SHARP, Sc. D., Director, Lewis Flight Propulsion Laboratory, Cleveland, Ohio  
WALTER C. WILLIAMS, B. S., Chief, High-Speed Flight Station, Edwards, Calif.



## REPORT 1304

# FLIGHT INVESTIGATION OF THE EFFECTIVENESS OF AN AUTOMATIC AILERON TRIM CONTROL DEVICE FOR PERSONAL AIRPLANES<sup>1</sup>

By WILLIAM H. PHILLIPS, HELMUT A. KUEHNEL, and JAMES B. WHITTEN

### SUMMARY

*A flight investigation to determine the effectiveness of an automatic aileron trim control device installed in a personal airplane to augment the apparent spiral stability has been conducted. The device utilizes a rate-gyro sensing element in order to switch an on-off type of control that operates the ailerons at a fixed rate through control centering springs. An analytical study using phase-plane and analog-computer methods has been carried out to determine a desirable method of operation for the automatic trim control.*

*Results indicate that the device is capable of maintaining the airplane in equilibrium over its operational speed range under directional out-of-trim conditions that would cause rapid divergence of the basic airplane. The device also prevents excessive heading wander and airplane gyrations in turbulent air without pilot control. A means for holding the airplane in a stabilized turn to facilitate mild maneuvering through the automatic control is provided.*

### INTRODUCTION

As a result of the present interest in the spiral-stability problem associated with most personal-owner airplanes, the National Advisory Committee for Aeronautics has undertaken a program to investigate the effectiveness of a spiral-stability augmenting device. The specific problem facing the pilot of a personal-owner airplane is to maintain his airplane in wings-level flight during times when he has no natural-horizon reference and to keep the airplane from diverging spirally while he may be preoccupied with navigational problems. It is demonstrated in reference 1 that the pilot's sense of orientation is unreliable in the absence of a visual reference, as may be the case when inadvertently or unavoidably encountering instrument weather. Also, many personal airplanes are equipped with only the basic instruments for instrument flight (turn indicator, ball-bank indicator, altimeter, and airspeed meter). Considerable proficiency in instrument flying is required to interpret the indications of these instruments properly and, in many cases, personal-airplane pilots are not sufficiently skilled in instrument flying to undertake it with safety.

Although most present-day personal-owner airplanes,

particularly those with high-wing designs, possess a slight degree of inherent spiral stability in cruising flight (ref. 2), they show unstable spiral tendencies under operational conditions. The main reasons for this apparent spiral instability are a lack of means for trimming the airplane laterally or directionally, a variation of lateral and directional trim with airspeed, and control-system friction which prevents the control surfaces from returning to trim position after a control deflection, even if there had been a means for initially trimming the airplane.

The use of preloaded control centering springs to alleviate the control friction problem is reported in reference 3. In reference 3, control centering devices were used on the ailerons and rudder with mechanical trim devices built into the centering units. The results of this investigation show that the apparent spiral stability is improved by the use of control centering springs as long as the surfaces are precisely trimmed for a particular flight condition. In order to be completely satisfactory, however, there is need for a means of automatically compensating for the lateral and directional trim changes resulting from changes in airspeed, power, loading, and altitude.

The purpose of the present investigation is to determine the effectiveness of an automatic trim device intended to compensate for the aforementioned variables affecting lateral and directional trim. The automatic trim device is designed to deflect the ailerons by shifting the trim position of preloaded control centering springs in order to maintain zero yawing velocity.

In the course of the analyses and tests, it became apparent that with certain minor additions the aileron control device could perform functions other than simply keeping the airplane trimmed laterally. It was possible for the device to provide rapid recovery to level flight from a banked attitude, to maintain a heading in smooth air with controls free for fairly long periods of time, to discourage large heading changes during flight in turbulent air, and to allow accurate corrections in heading for navigation purposes. In these respects, the aileron control device performed functions of an autopilot with considerably less complication than any conventional autopilot known to be in use at present.

<sup>1</sup> Supersedes NACA Technical Note 3637 by William H. Phillips, Helmut A. Kuehnel, and James B. Whitten, 1956.



## SYMBOLS

$b$	wing span, ft
$C$	arbitrary constant of integration
$C_L$	lift coefficient, $Lift/qS$
$C_Y$	lateral-force coefficient
$C_{Y\beta}$	variation of lateral-force coefficient with sideslip $\partial C_Y/\partial\beta$
$C_{Y\delta_r}$	variation of lateral-force coefficient with rudder deflection, $\partial C_Y/\partial\delta_r$
$C_l$	rolling-moment coefficient, $\frac{\text{Rolling moment}}{qSb}$
$C_{l_p}$	variation of rolling-moment coefficient with rolling angular-velocity factor, $\partial C_l/\partial\frac{pb}{2V}$
$C_{l_r}$	variation of rolling-moment coefficient with yawing angular-velocity factor, $\partial C_l/\partial\frac{rb}{2V}$
$C_{l\beta}$	variation of rolling-moment coefficient with sideslip, $\partial C_l/\partial\beta$
$C_{l\delta_a}$	variation of rolling-moment coefficient with aileron deflection, $\partial C_l/\partial\delta_a$
$C_n$	yawing-moment coefficient, $\frac{\text{Yawing moment}}{qSb}$
$C_{n_p}$	variation of yawing-moment coefficient with rolling- angular-velocity factor, $\partial C_n/\partial\frac{pb}{2V}$
$C_{n_r}$	variation of yawing-moment coefficient with yawing- angular-velocity factor, $\partial C_n/\partial\frac{rb}{2V}$
$C_{n\beta}$	variation of yawing-moment coefficient with sideslip, $\partial C_n/\partial\beta$
$C_{n\delta_r}$	variation of yawing-moment coefficient with rudder deflection, $\partial C_n/\partial\delta_r$
$g$	acceleration due to gravity
$h_i$	indicated altitude, ft
$K$	constant used in phase-plane computation, $\frac{b}{4} \frac{C_{l_p}}{C_{l\delta_a} \delta_a}$
$K_X$	ratio of radius of gyration about X-axis to span
$K_Z$	ratio of radius of gyration about Z-axis to span
$K_1$	gearing constant (fig. 4)
$P$	period of oscillation, sec
$p$	rolling angular velocity deg/sec
$q$	dynamic pressure
$r$	yawing angular velocity, deg/sec
$S$	wing area, sq ft
$t$	time, sec
$V$	airspeed, ft/sec
$V_i$	indicated airspeed, mph
$\beta$	angle of sideslip, deg
$\delta_a$	total aileron deflection, deg
$\dot{\delta}_a$	total-aileron-deflection rate, deg/sec
$\delta_{a,A}$	total automatic aileron angle, deg
$\delta_{a,0}$	initial value of aileron angle, deg
$\delta_\sigma$	tilt angle of spin axis of rate gyro, deg
$\delta_r$	rudder deflection, deg

$\mu$	airplane relative-density coefficient, $\frac{\text{Mass}}{\rho S b}$
$\rho$	air density
$\phi$	angle of roll, deg
$\phi_0$	initial angle of roll, deg
$\psi$	angle of yaw or heading change, deg

Total aileron deflection is used throughout the report.

#### PRINCIPLE OF OPERATION OF THE AUTOMATIC AILERON TRIM CONTROL DEVICE

The automatic aileron trim control device as originally proposed consisted of an improvement of the manually trimmed preloaded centering springs which had been previously applied to the aileron and rudder controls of a personal-owner airplane (ref. 3). The improvement consisted in making the trim automatic by slowly shifting the trim position of the springs by means of a small electric motor. The direction of rotation of the motor was controlled by a pair of contacts on a gyro sensitive to yawing velocity.

With the automatic trim feature present, the use of devices on both the aileron and the rudder controls was considered unnecessary. The aileron control was selected as the most desirable for incorporation of the device, because the aileron deflection and force required to offset an out-of-trim condition (such as might be caused by asymmetric fuel consumption, power changes, or airspeed changes) are usually much less than the rudder deflection and force, and because the sideslip angle resulting from the ailerons is, in most cases, less than that from the rudder.

The use of a slow-speed on-off type of motor has the advantage of reducing the power required to operate the device. The power requirements are reduced both because the total travel provided by the motor which operates the ailerons should be enough to offset only possible out-of-trim moments on the airplane, and because the rate of motion can be relatively low. Most autopilots utilize a servomotor which provides a control deflection proportional to the quantity sensed. This arrangement requires the servomotor to operate rapidly enough to follow short-period motions of the airplane; otherwise, the lag in the control operation might cause dynamic instability. The resulting power requirements are much greater than would be needed to operate the controls at a slow rate to offset the spiral divergence of an airplane.

A gyro sensing angular velocity was selected to operate the device because such a gyro is simpler and less expensive than a displacement gyro. Because angle of roll is proportional to yawing velocity during a steady turn, a yaw rate gyro performs the same function in the present application as a roll attitude gyro. Both these instruments would have the disadvantage of allowing slow changes in heading within the resolution of the instrument. A means of detecting direction with respect to geographical or magnetic references would be required to maintain heading constant over long



periods of time. Because the main purpose of the present device is to prevent excessively steep spirals during instrument flight, the rate gyro was considered adequate.

The preloaded centering springs were considered an essential feature of the device in contributing to safety under emergency conditions. These springs require a definite force to displace the aileron control from the trim position. If, under instrument conditions, the pilot becomes disoriented, he is assured that on releasing the control the ailerons will snap to the position required to maintain the wings level. With a less positive method of applying torque to the aileron control system, control friction might interfere with the correct operation of the device. The preloaded centering springs were shown in reference 3 to be desirable during cross-country flight where frequent maneuvering is not required. Provision could be made, of course, for readily disconnecting the device under contact flight conditions if desired.

The preceding discussion has presented the justification for the basic idea of the aileron trim device. This device is now analyzed by using phase-plane and analog-computer methods. Modifications for overcoming stability problems associated with the basic system are discussed.

#### ANALYTICAL STUDY OF AUTOMATIC AILERON TRIM CONTROL DEVICE

##### PHASE-PLANE AND ANALOG-COMPUTER STUDY

A nonlinear system such as the aileron trim device may be analyzed by the phase-plane method. In this method, the motion of the system is calculated by plotting velocity against displacement. For the present system which is intended to maintain the airplane near zero roll, a plot of rolling velocity as a function of roll displacement is most suitable.

The trajectories of the motion in the phase plane may be readily calculated under the simplifying assumption that, for the long-period motions under consideration, the rolling velocity is proportional to the aileron deflection. This assumption neglects lag in development of the rolling motion and considers the inherent spiral stability or instability of the airplane to have a minor effect on roll rate as compared with aileron deflection. The rolling velocity is then given by the formula

$$\frac{pb}{2V} = \frac{\delta_a C_{l_{\delta_a}}}{C_{l_p}}$$

or

$$p = \delta_a \frac{2V}{b} \frac{C_{l_{\delta_a}}}{C_{l_p}}$$

If the ailerons are assumed to move at a constant rate  $\dot{\delta}_a$ , then

$$\delta_a = \delta_{a,0} + \dot{\delta}_a t$$

Hence,

$$p = (\delta_{a,0} + \dot{\delta}_a t) \frac{2V}{b} \frac{C_{l_{\delta_a}}}{C_{l_p}} \quad (1)$$

and

$$\phi = \left( \delta_{a,0} t + \frac{\dot{\delta}_a t^2}{2} \right) \frac{2V}{b} \frac{C_{l_{\delta_a}}}{C_{l_p}} + C \quad (2)$$

If  $t$  is eliminated between equations (1) and (2),

$$\phi = \frac{p^2}{\dot{\delta}_a} \frac{b}{4V} \frac{C_{l_p}}{C_{l_{\delta_a}}} + C \quad (3)$$

Let

$$K = \frac{b}{4} \frac{C_{l_p}}{C_{l_{\delta_a}} \dot{\delta}_a}$$

Hence,

$$\phi = \frac{K p^2}{V} + C \quad (4)$$

From this relation, the trajectories in the phase plane are seen to be parabolas. These trajectories are sketched in figure 1 (a) for the particular set of conditions given in table I.

In a steady turn, the relationship between rolling and yawing velocity is

$$\phi = \frac{V}{g} r \quad (5)$$

If it is assumed that short-period oscillations are absent, the gyro sensing yawing velocity will cause the ailerons to reverse when  $\phi = 0^\circ$ . If the airplane is released from an initial roll angle with the ailerons in the neutral position, the action of the control device will, therefore, cause the airplane to follow a trajectory shown by the heavy line in figure 1 (a). This trajectory represents a continuous oscillation of long period, the amplitude of which equals the initial roll angle. The period of the oscillation is given by the formula

$$P = 8 \sqrt{\frac{\phi_0 K}{V}} \quad (6)$$

It may be noted that provision of a dead zone between the gyro contacts will not add damping to the oscillation. The trajectories in this case are shown in figure 1 (b). The ailerons remain fixed when the contacts are in the dead zone. The airplane, therefore, coasts across this region with constant rolling velocity.

Inasmuch as the preceding analysis required several simplifying assumptions, a more exact analysis was made by utilizing a Reeves Electronic Analog Computer (REAC). In this analysis the lateral motion of the airplane was represented by the conventional equations using three degrees of freedom. The airplane characteristics assumed are given in table I. These characteristics are not intended to apply to the airplane later used in the flight investigation. The ailerons were assumed to move at a constant rate and the rate was assumed to reverse instantly when the yawing velocity passed through zero. First, a time history of the motion of the uncontrolled airplane when it is released from



TABLE I.—FLIGHT CONDITIONS AND PARAMETERS USED FOR PHASE-PLANE AND REAC COMPUTATIONS

$V$ , mph	140
$b$ , ft	32.8
$\delta_a$ , deg/sec	0.5
$K$ , ft/radian/sec	4.470
$C_{l_p}$ per radian	-0.45
$C_{l_{\dot{\beta}}}$ per radian	-0.0945
$C_{l_{\dot{\phi}}}$ per radian	-0.0585
$C_{l_r}$ per radian	0.0612
$C_{n_{\dot{\beta}}}$ per radian	0.0825
$C_{n_p}$ per radian	-0.0144
$C_{n_r}$ per radian	-0.103
$C_{n_{\dot{\phi}}}$ per radian	0.0825
$C_{Y_{\dot{\beta}}}$ per radian	-0.407
$C_{Y_{\dot{\phi}}}$ per radian	0.0756
$K_X$	0.103
$K_Z$	0.168
$\mu$ , $\frac{\text{Mass}}{\rho S b}$	5.63
$C_L$	0.278

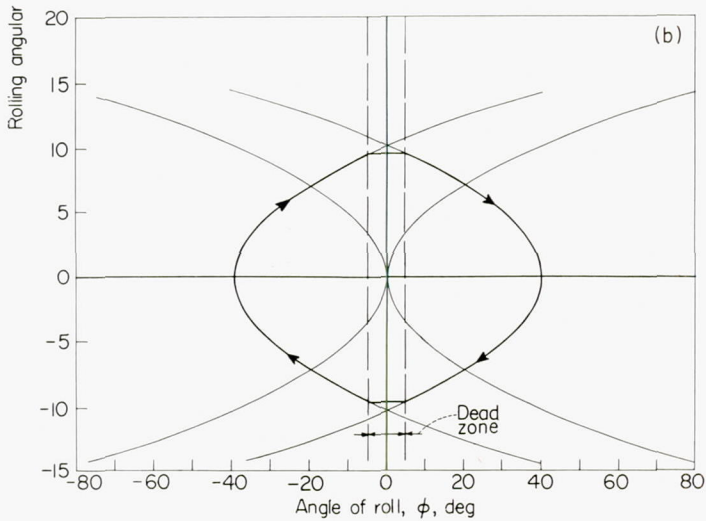
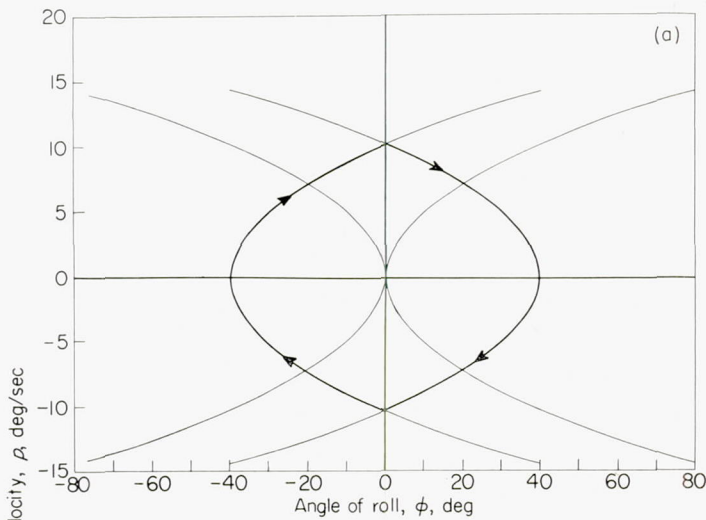

(a) No dead zone.  
(b) A dead zone in the gyro contacts.

FIGURE 1.—Trajectories of the assumed airplane motion in the phase plane for the conditions given in table I with automatic control reversing when  $\theta=0^\circ$ .

a  $40^\circ$  roll angle is shown in figure 2 (a). The basic airplane as simulated on the REAC requires about 30 seconds to return to one-half the initial amplitude with the airplane in perfect trim. As shown in figure 2 (b), the motion of the airplane with the automatic control in operation is seen to perform an almost undamped oscillation with a period of 26.9 seconds. This result is in good agreement with the value of 27.0 seconds predicted by equation (6) for an amplitude equal to the average amplitude shown in figure 2 (b). The only differences in the more exact solution are the appearance of the brief short-period Dutch roll oscillation at the start of the motion and the slow damping of the long-period motion resulting from the spiral stability of the airplane assumed in the analog-computer study.

In order to improve the damping of the long-period oscillation, the motion of the ailerons should reverse before the yawing velocity is zero, so that the ailerons may return

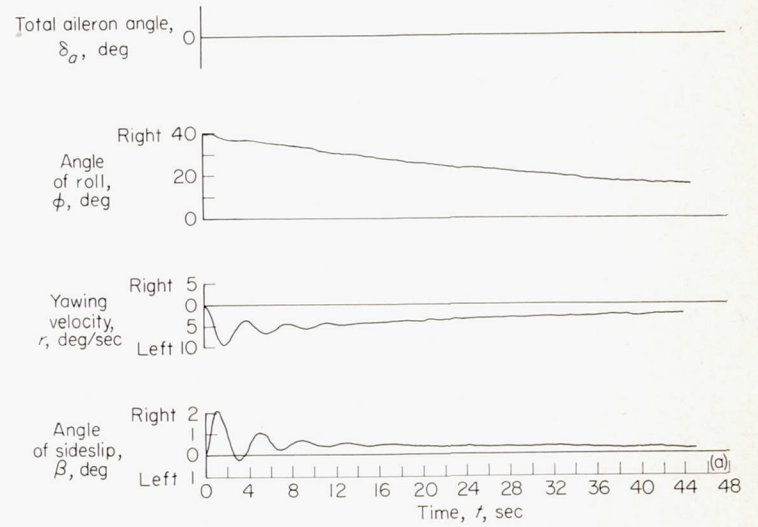

(a) Basic airplane released from a  $40^\circ$  roll angle.

FIGURE 2.—Time history of the motion of the basic airplane and airplane with automatic control obtained from REAC solutions.

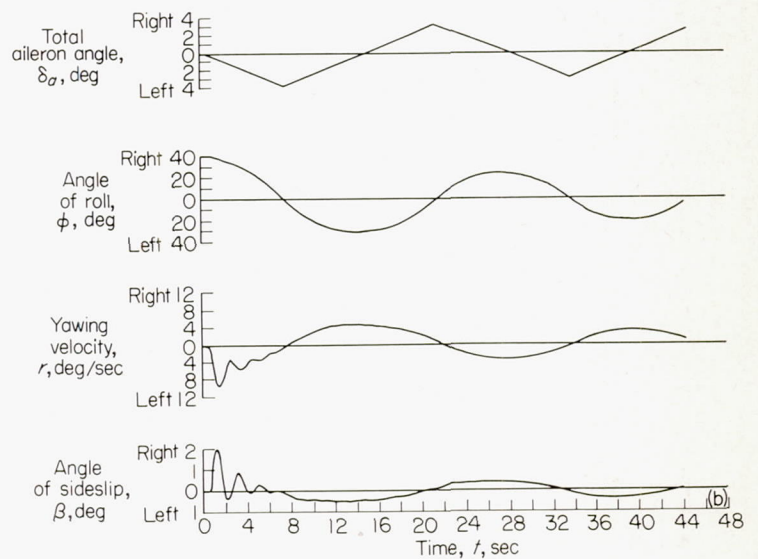

(b) Ailerons reverse when  $r=0^\circ$ . Airplane released from a  $40^\circ$  roll angle

FIGURE 2.—Concluded.



to neutral when the roll angle is zero. Ideally, the aileron rate should reverse on a "switching curve" consisting of the trajectory on the phase plane passing through the origin, as shown by the dashed-line curve in figure 3 (a). The airplane would then perform a dead-beat return to zero roll.

As an approximation to this ideal parabolic switching curve, a straight line may be used, as shown in figure 3 (b). Initially, it was proposed that this method of operation be mechanized by applying to the gyro gimbal a torque proportional to aileron deflection. Since rolling velocity is proportional to aileron deflection, this torque will cause the gyro contacts to reverse when a certain ratio exists between rolling velocity and yawing velocity. A typical REAC solution for this arrangement is shown in figure 4. This figure illustrates that a return to zero roll in 8 seconds may be obtained with little overshoot even with a rate of total aileron motion as low as  $\frac{1}{2}^\circ$  per second.

The method of obtaining damping of the motion by applying a torque to the gyro gimbal proportional to aileron

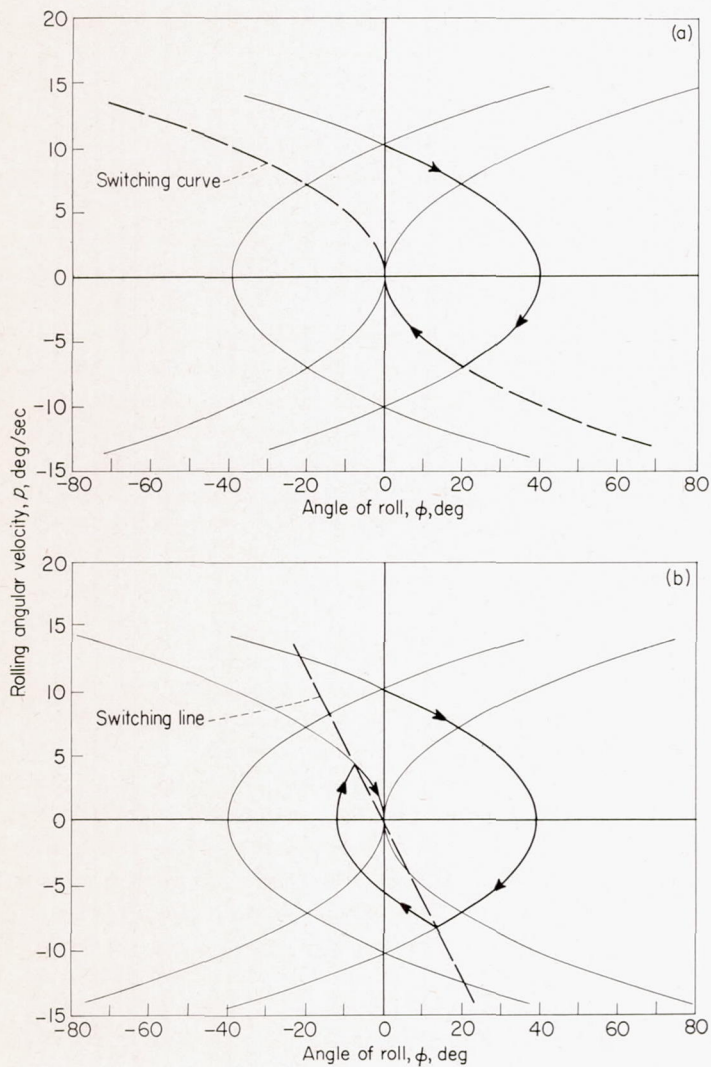

(a) Control reverses on ideal switching curves.  
 (b) Control reverses on a straight-line approximation to the ideal switching curve.

Figure 3.—Trajectories of the assumed airplane motion in the phase plane for the conditions given in table I with automatic control reversing as the motion crosses the switching curve.

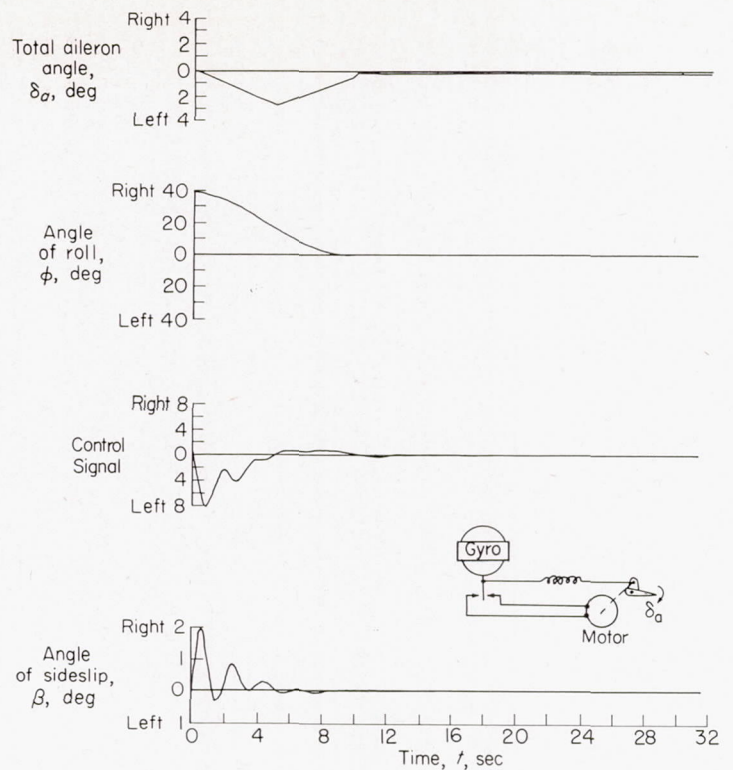

Figure 4.—Time history of the airplane motion obtained on the REAC with the automatic control reversing when  $r + K_1\delta_a = 0$ . ( $K_1$  is a gearing constant.)

deflection has the disadvantage that, if any aileron deflection is required for lateral trim, the airplane will stabilize in a steady turn rather than in a straight course. A method was, therefore, sought to slowly wash out the aileron-deflection signal under steady conditions. Analysis and flight testing of devices operating on this principle were conducted, but none of these devices were as simple as desired. Eventually, it was realized that the desired reversal of the gyro contacts at a given ratio between rolling and yawing velocity could be obtained by tilting the spin axis of the gyro. This method does not have the disadvantage of making the airplane stabilize in a steady turn under out-of-trim conditions. The method appears so much simpler and more advantageous than the others tried that no further discussion of any other method is presented.

CALCULATION OF OPTIMUM GYRO TILT

In order to compute approximately the desired angle of tilt of the gyro, the relations developed in the previous phase-plane analysis may be employed. Assume a gyro with spin axis tilted at an angle  $\delta_g$  from the flight path. The components of yawing and rolling velocities about the sensitive axis are shown in figure 5. The gyro contacts reverse when the resultant of the components of yawing and rolling velocities about the sensitive axis equal zero, that is, when

$$r \cos \delta_g + p \sin \delta_g = 0$$

Hence,

$$-\tan \delta_g = r/p \tag{7}$$

The relation between  $r$  and  $p$  required for reversal of the gyro contacts to obtain a dead-beat return to zero roll is



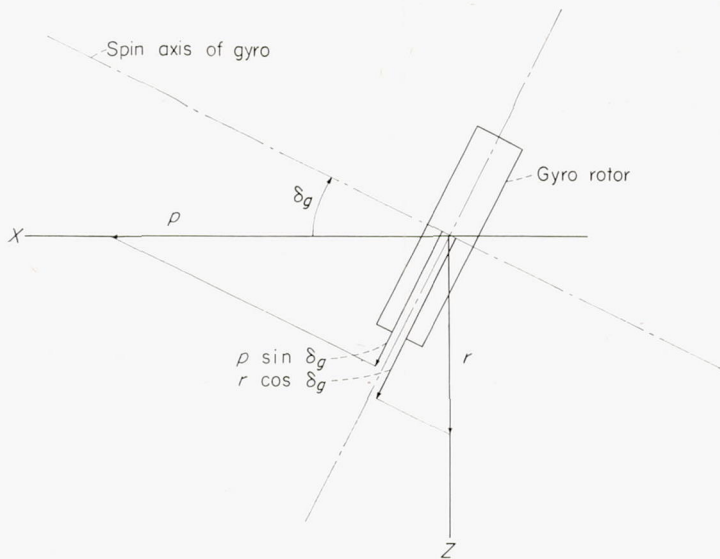

FIGURE 5.—Geometric relationships used in the computation of an optimum gyro tilt angle.

obtained from the equation of the phase-plane trajectory that passes through the origin. For this trajectory, it may be shown from equation (4) that

$$\frac{\phi}{p} = -\sqrt{\frac{K}{V}} \sqrt{\phi}$$

The value of  $C$  is zero for this trajectory, and the minus sign is used to correspond to trajectories for which  $\phi$  and  $p$  have opposite signs. Substituting the value of  $\phi$  from equation (5) into the left-hand side of this equation gives

$$\frac{r}{p} = -\frac{g\sqrt{K}}{V^{3/2}} \sqrt{\phi}$$

If this value is equated to the value of  $r/p$  in equation (7), the value of gyro tilt which gives a dead-beat return from any given roll angle  $\phi$  may be determined as follows:

$$\tan \delta_g = \frac{g\sqrt{K}}{V^{3/2}} \sqrt{\phi}$$

For the conditions given in table I ( $V=140$  mph) and an initial roll angle  $\phi$  of  $40^\circ$ , the gyro-tilt angle is  $38.4^\circ$ , with the gyro inclined above the flight path. If the airspeed is reduced to 90 mph, the tilt is  $55^\circ$ . Note that the change in angle of attack due to the reduced airspeed automatically provides some increase in gyro tilt in the required direction. For the particular condition under consideration, the angle-of-attack change of about  $10^\circ$  as the airspeed is reduced from 140 mph to 90 mph is compared with a change in tilt of  $16.6^\circ$  calculated for optimum response.

#### DESCRIPTION OF APPARATUS

A pictorial diagram and circuit-wiring diagram of the automatic control device is shown in figure 6. The pictorial diagram indicates schematically the interconnection of the

various components described subsequently. The interconnection is shown in detail in the circuit-wiring diagram.

A photograph of the rate-gyro installation is shown in figure 7. This gyro is a well-constructed unit taken from other equipment and is perhaps larger and more sensitive than necessary for the job. The unit has a 5.2-ounce rotor with a rotor moment of inertia of about 0.24 lb-in.<sup>2</sup> and requires 28 volts at 0.22 ampere. The unit has built-in electrical contacts and a means for electrically applying a torque about the gyro precession axis.

The actuator unit, consisting of the preloaded aileron centering springs and the electric motor and gear box, is shown mounted on the control column in figure 8. Figure 9 shows the force characteristics of the aileron control system as measured on the ground. As seen from this figure, the preload is about equal to the static control-system friction. The electric motor is a small, permanent-magnet type of unit internally geared down to 250 rpm. External gearing of the motor reduces the jack-screw rotational speed to about 42.4 rpm. The resulting linear speed of the jack-screw nut is about 4 in./min and results in total deflection rate of the aileron of  $1.5^\circ$  per second. Automatic-total-aileron travel is limited to about  $\pm 5^\circ$ . The power requirement for the actuator is about 0.2 to 0.3 ampere at 28 volts under normal load. Manual aileron control of the airplane is available at all times by overpowering the preloaded control centering springs.

Switches sensitive to aileron wheel force are mounted between the control-wheel shaft and the control wheel. About  $2^\circ$  of rotational free play is provided between the wheel and shaft. Two microswitches are mounted rigidly to the wheel shaft, and an arm that rests between the micro-switch buttons is mounted rigidly to the control wheel. The control wheel is preloaded to the center of the free-play zone between wheel and wheel shaft. This preload is adjusted to maintain both of the switches in an off condition when no force is applied to the wheel. A photograph of the force-switch installation is shown in figure 10, and the position of these switches in the system is shown in figure 6. These switches are actuated by a relatively light wheel force (less than that of the aileron preload) and, as seen from figure 6, apply a voltage to the torque coil built into the gyro unit. By this means, a torque is applied to the gyro about its precession axis, thus closing a gyro contact and exciting the aileron servomotor. The resulting aileron deflection establishes a turn rate which will stabilize at the point where the precession torque due to the turn rate is equal and opposite to the electrically applied precession torque. An electrical precession torque equivalent to that resulting from a turn rate of  $3^\circ$  per second was used.

The control circuitry consists of a relay pair actuated by the gyro contacts for the purpose of switching the relatively high current to the actuator motor through heavy relay contacts instead of through the light gyro contacts. Provision is also made for manually motoring the actuator, and a pair of pilot lights is provided to indicate the direction of actuator excitation.



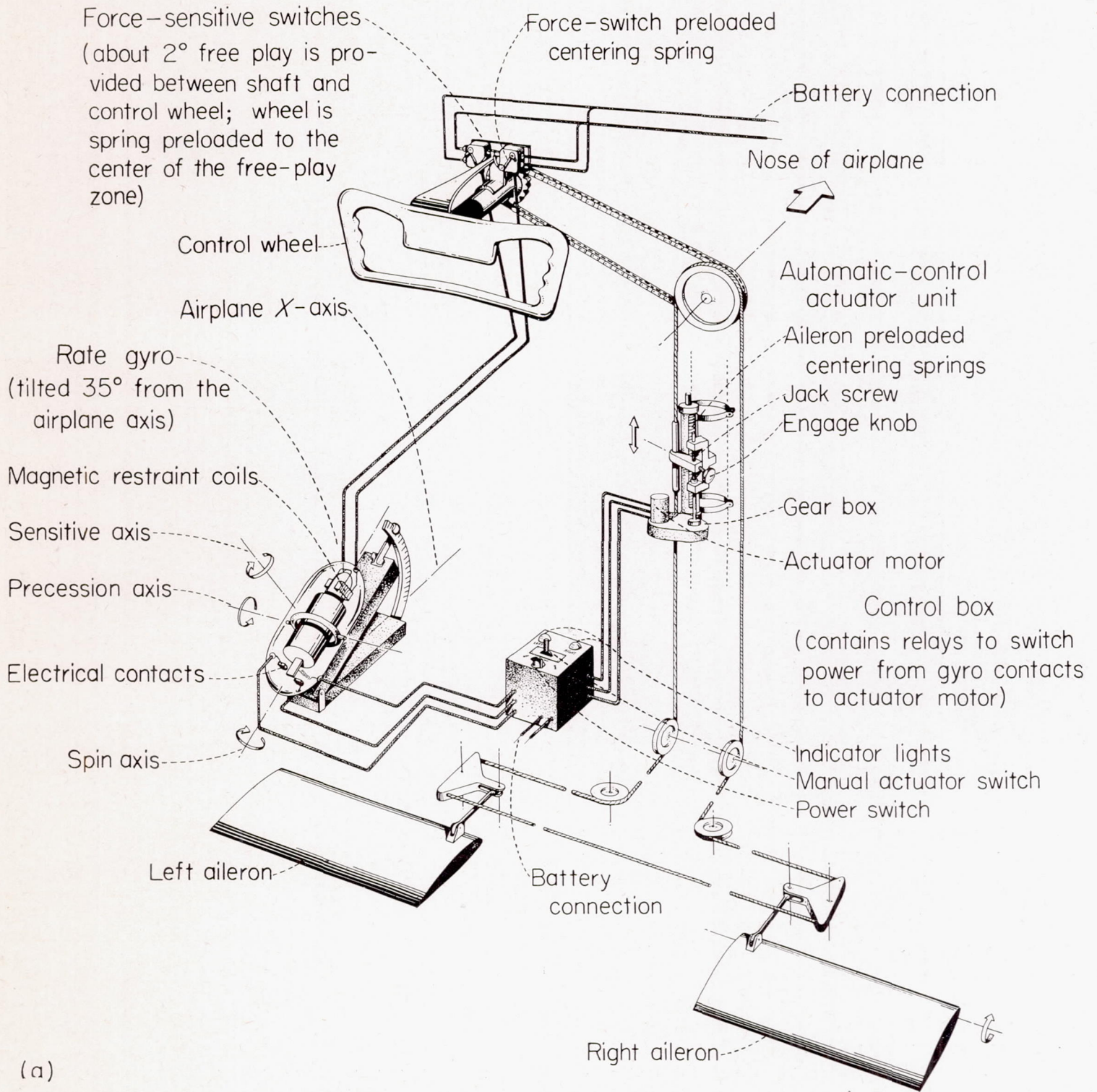

(a)

(a) Pictorial diagram of control circuit.

FIGURE 6.—Automatic-control-circuit diagram shown in pictorial and schematic wiring diagrams.



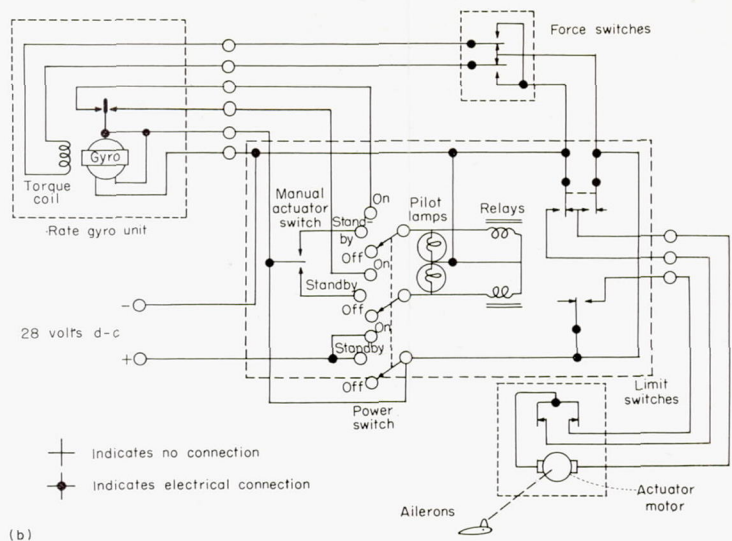

(b) Schematic wiring diagram of control circuit.

FIGURE 6.—Concluded.

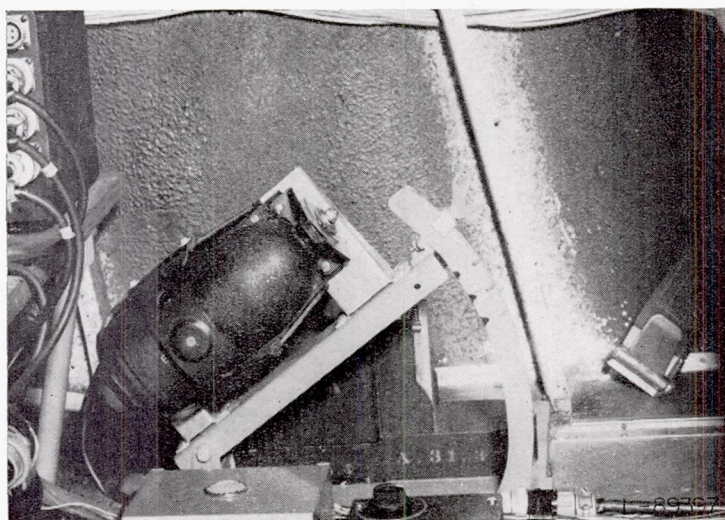

FIGURE 7.—Photograph of rate gyro installed in the test airplane.

**TEST AIRPLANE**

The test vehicle used for this investigation is a typical high-wing personal-owner airplane shown in the photograph in figure 11. Complete details of the airplane are tabulated in reference 3.

The basic airplane does not incorporate any means for directional trim but does have an adjustable bungee aileron trim device.

**INSTRUMENTATION**

Standard NACA recording instruments are employed to record indicated airspeed; pressure altitude; yawing velocity; rolling velocity; heading change; pitch angle; sideslip angle; roll angle; and normal, transverse, and longitudinal acceleration and control positions, referred to the fixed surfaces.

Static and dynamic pressures for the altitude and airspeed recorders are taken from the airplane system which has an approximate 1/2-chord boom mounted on the leading edge

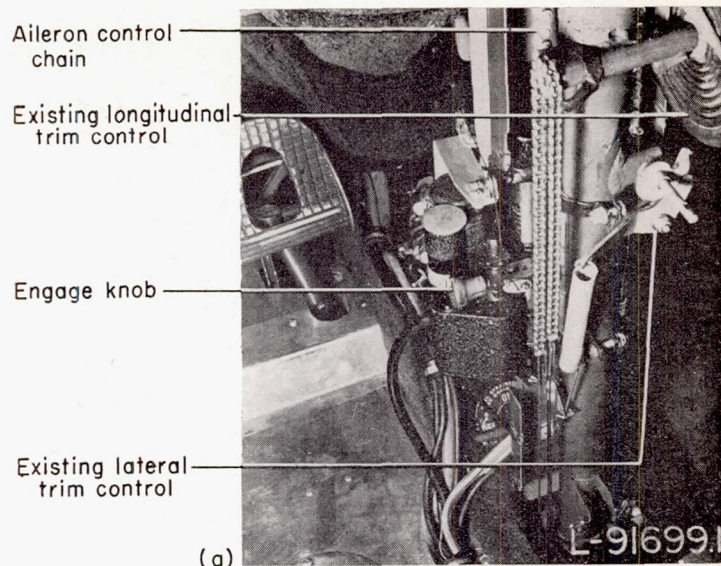

(a)

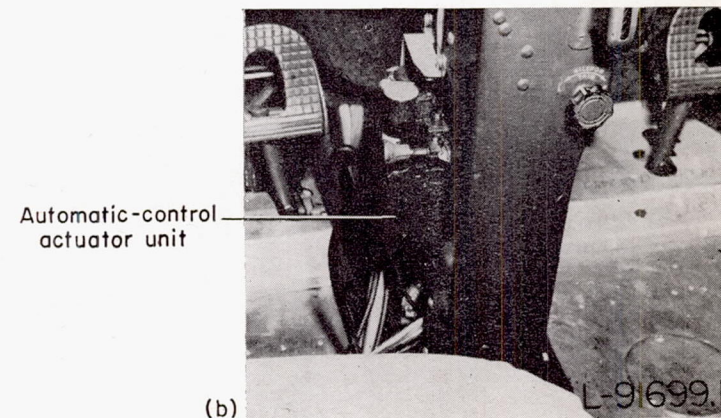

(b)

(a) Control column fairing removed.  
(b) Control column fairing in place.

Figure 8.—Photograph of the actuator unit installed on the control column of the test airplane.

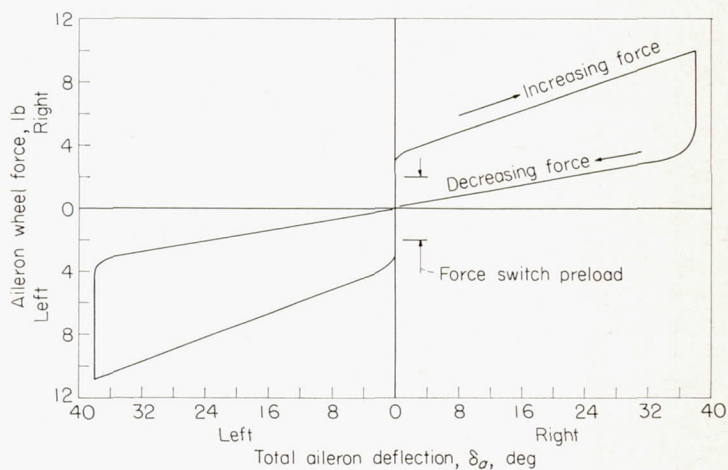

FIGURE 9.—Ground measurement of the preloaded aileron centering-spring force-deflection characteristics with increasing and decreasing wheel force.



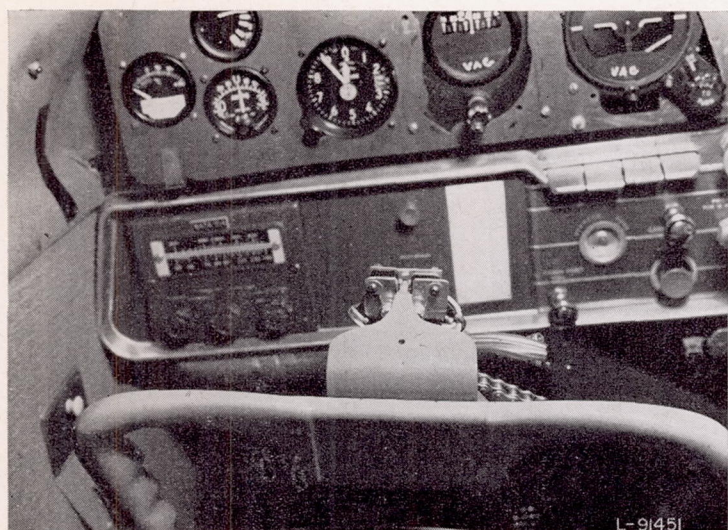

FIGURE 10.—Photograph of the force switches mounted on the control wheel shaft of the test airplane.

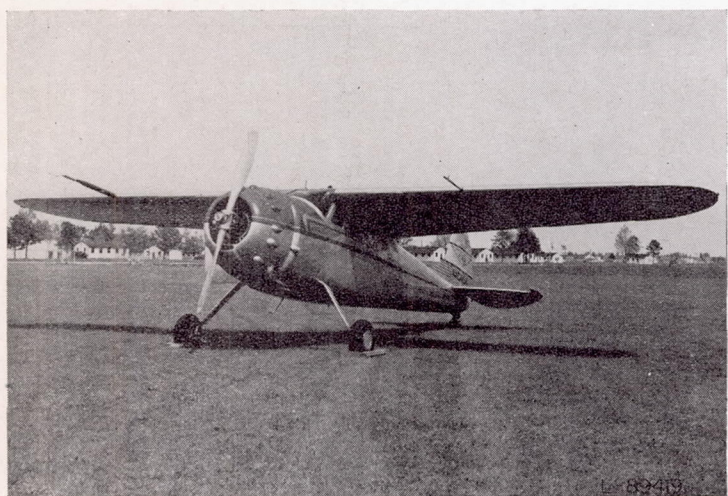

FIGURE 11.—Photograph of test airplane.

of the wing at about one-half span. The airplane pilot's instruments are supplemented with a gyro horizon and directional gyro to assist in pilot evaluation of the effectiveness of the automatic device.

Automatic-control actuator position is recorded and presented as control aileron deflection on the time-history plots presented subsequently. This record trace provides a sensitive measure of aileron deflection when the pilot is not overpowering the preloaded centering springs. Centering-spring position is also recorded on an NACA control position recorder, and the plot is calibrated in terms of total aileron deflection. Deflection of the centering springs as indicated by a movement of this trace indicates that the pilot is overpowering the preloaded centering springs.

Neither of the previously mentioned two quantities were recorded with the automatic control disengaged.

#### DISCUSSION OF RESULTS

Performance of the automatic aileron trim control system used in this investigation and a comparison with the basic

airplane (airplane without automatic control) are shown in figures 12 to 21.

#### BASIC AIRPLANE

Figures 12 to 15 document the performance of the basic airplane when released from about a  $20^\circ$  roll angle and when directionally out-of-trim because of a speed change from trim speed. The test airplane is rigged to be in trim directionally at an indicated airspeed of 135 mph at a 5,000-foot altitude. The aileron bungee was used to trim the airplane laterally at the same speed, and this trim setting was maintained in the subsequent tests.

Recovery of the basic airplane from a right roll (fig. 12) and a left roll (fig. 13) differs appreciably. This difference is due to the effect of speed change on directional trim after the controls are released. In figure 12 the increased airspeed causes the airplane to be out of trim to the right, thus hampering recovery from the initial roll. In figure 13 the initial increased airspeed causes a favorable trim change, thus aiding the initial return to level flight; however, the airplane overshoots the wings-level attitude and terminates in a right-hand turn.

The controls are released in figure 14 after the airspeed has been reduced to 90 mph from a trim speed of 135 mph and in figure 15 after the airspeed has been increased to 150 mph from the trim airspeed of 135 mph. Divergence of the airplane due to being directionally out of trim as a result of airspeed change is obvious from the figures. These results should be compared with those of similar maneuvers presented subsequently with the automatic control operating.

#### AIRPLANE WITH AUTOMATIC CONTROL

The automatic-control engagement procedure that was followed throughout the flight investigation consisted first of trimming the airplane laterally and longitudinally at an airspeed of 135 mph and an altitude of 5,000 feet. The aileron centering springs were then mechanically engaged to the control cables. The power switch was turned to automatic, thereby energizing the electrical circuits and putting the system in operation. The power switch was in standby from take-off to assure that the gyro was up to rated speed when tests were started. The airplane was not retrimmed laterally for the different flight conditions investigated.

A range of gyro-tilt angles was investigated to determine an optimum value applicable over the operational speed range of the test airplane. At zero tilt, the automatic control produced a continuous long-period oscillation as is predicted by theory for the condition of control effort reversing when  $r$  is zero. This theoretical result was shown in figure 2 (b). As the gyro-tilt angle was increased, the control effort reversed before zero yawing velocity, therefore adding damping. A gyro-tilt angle of  $35^\circ$  up with respect to the airplane axis was found to be an optimum average value over the airplane speed range, and it is the value used in obtaining the subsequent time-history records.



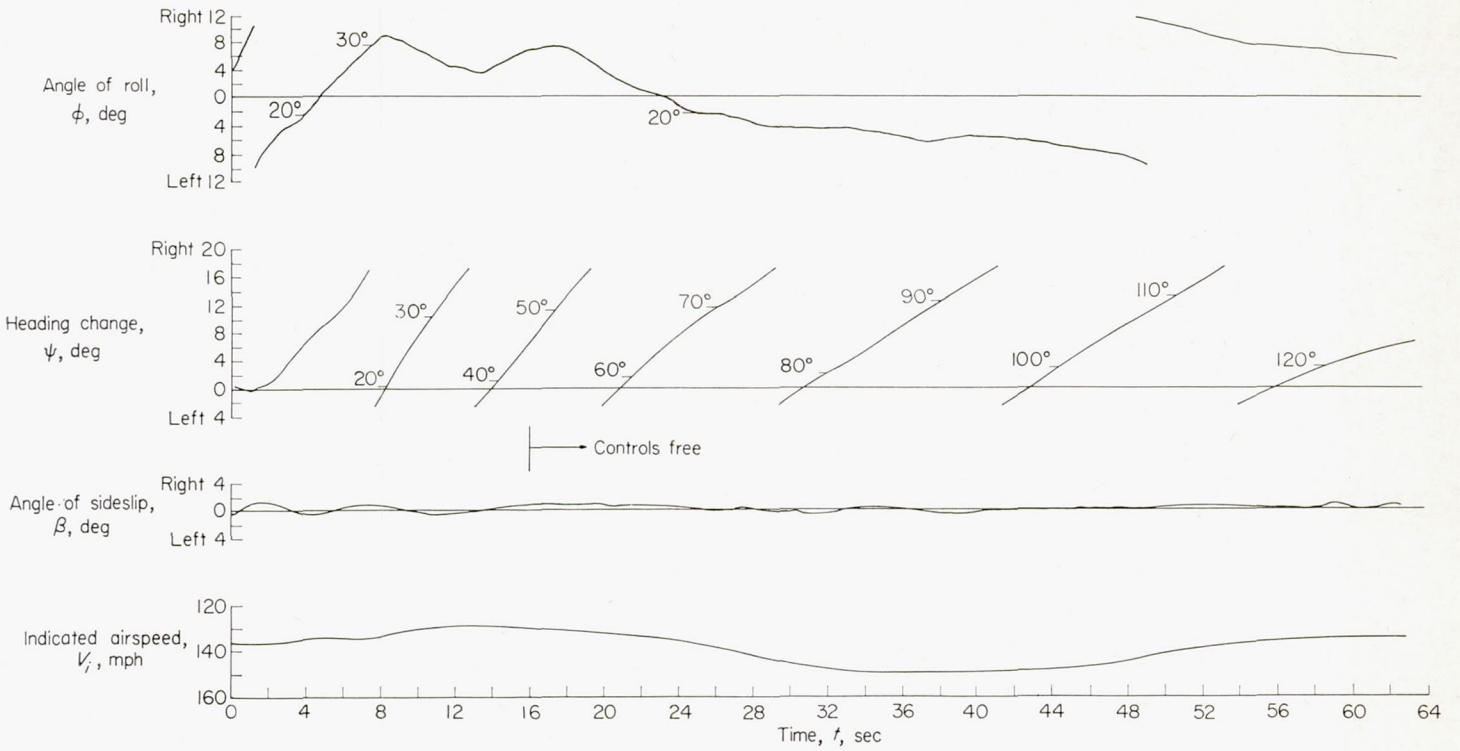

FIGURE 12.—Time history of the basic airplane motions. Pilot performs a 45° heading change and releases the controls from about a 20° right roll.  $V_i=135$  mph;  $h_i=5,000$  feet.

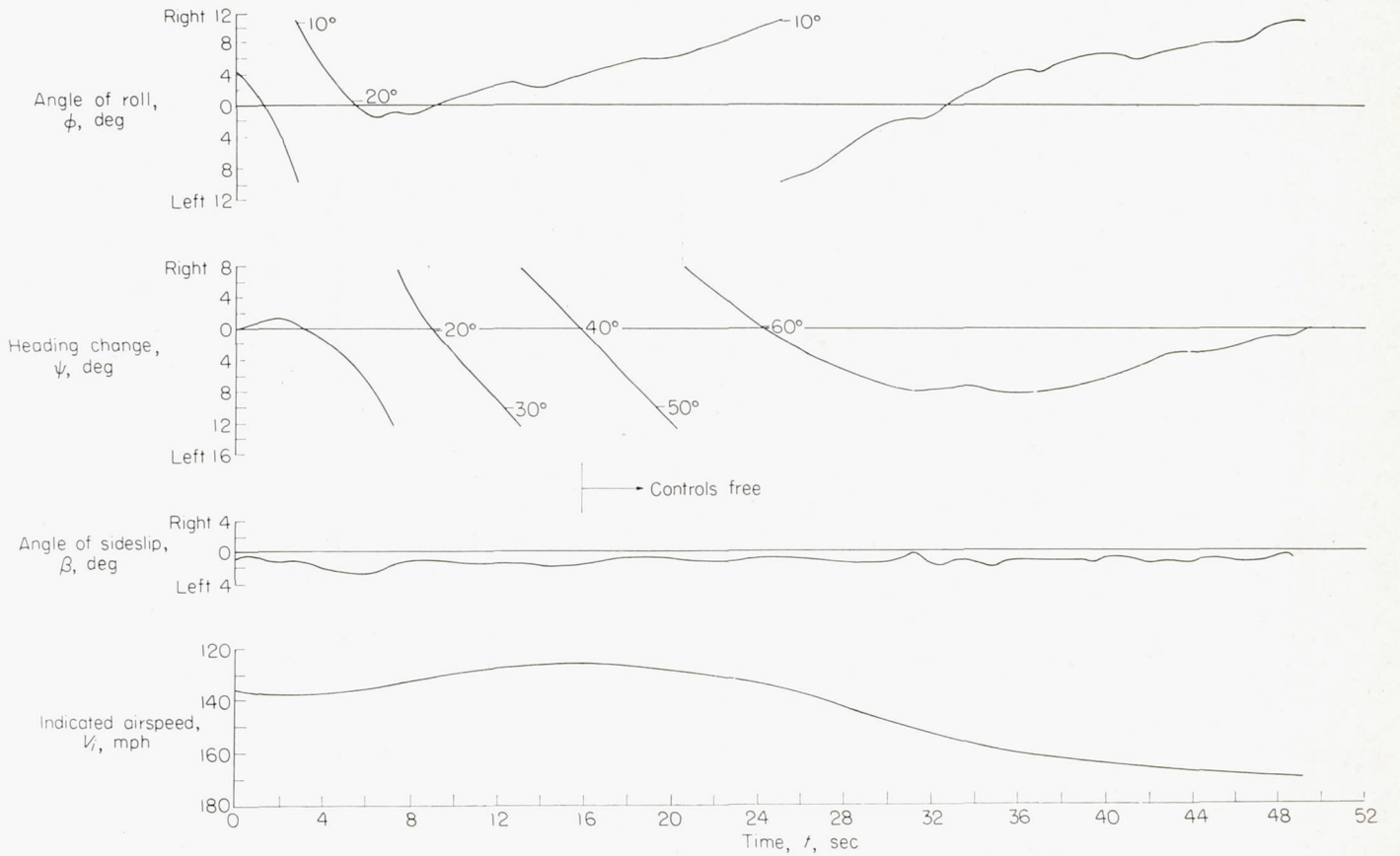

FIGURE 13.—Time history of the basic airplane motions. Pilot performs a 45° heading change and releases the controls from about a 20° left roll.  $V_i=135$  mph;  $h_i=5,000$  feet.



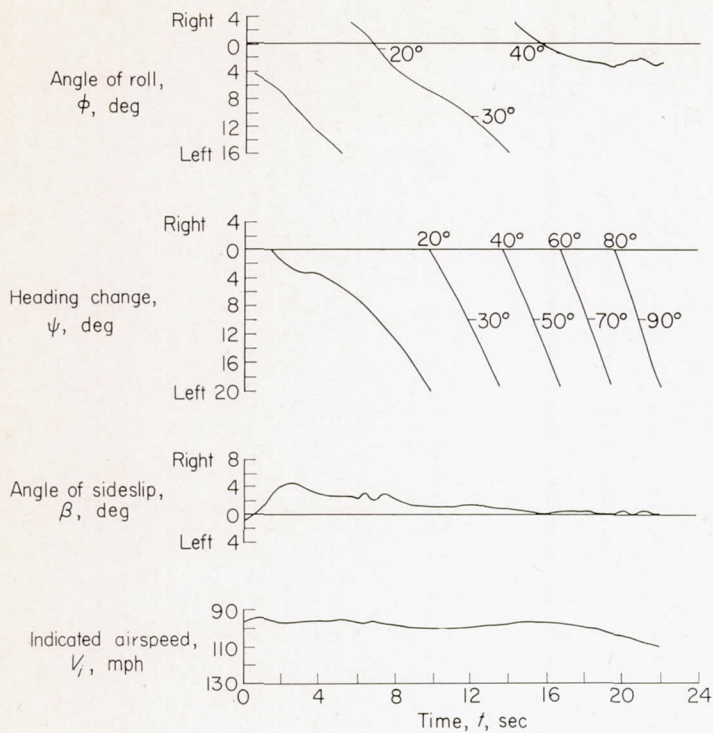

Figure 14.—Time history of the basic airplane motions. Pilot releases the controls from level flight after the airspeed has been reduced to 90 mph from a trim speed of 135 mph.

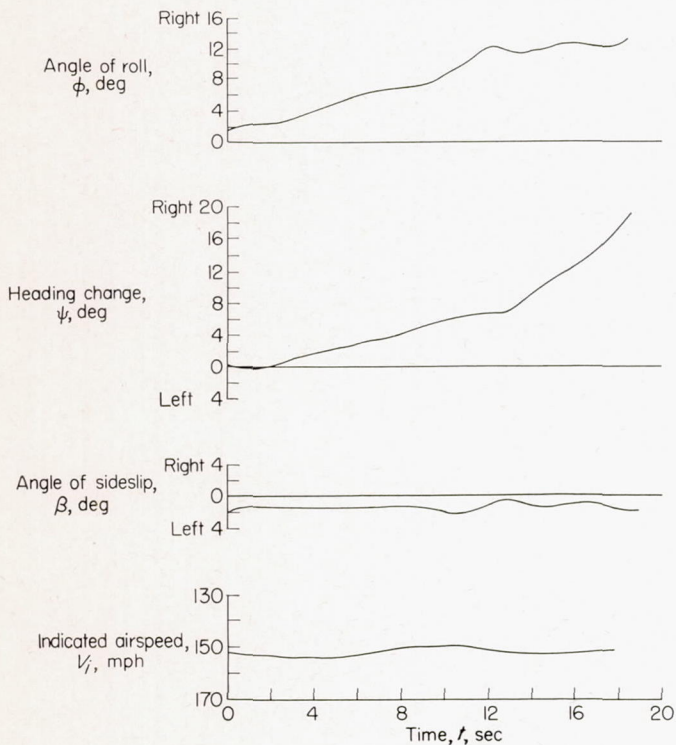

FIGURE 15.—Time history of basic airplane motions. Pilot releases the controls from level flight after the airspeed has been increased to 150 mph from a trim speed of 135 mph.

In figure 16 the pilot performs a manual 45° heading change to the right with the automatic control engaged and releases the airplane controls from about a 20° roll angle. During the manual-turn portion of the record it will be noted that the pilot must hold some control wheel force in the steady turn as indicated by the centering-spring deflection (calibrated in degrees of aileron deflection). Also, it should be noted from the automatic aileron trace that the ailerons move to the limit of actuator travel to oppose the steady turn. After the pilot releases the manual controls, the automatic aileron deflection rolls the airplane back to level flight in about 10 seconds. When looking at the automatic-aileron-angle trace, the motion appears to slow down gradually as the roll angle approaches zero, as might be expected with a linear system rather than with the on-off type of system used in this investigation. This apparent linear action is explained by the rate-gyro contacts chattering at low levels of precession torque when the angular velocity about the gyro sensitive axis is near zero. This action contributes to the smooth manner in which the system rapidly approaches zero yawing velocity with little or no overshoot.

Performance of the system at a reduced airspeed of 90 mph with the airplane out of trim to the left is demonstrated in figure 17 in which the airplane is released from a left roll angle. The airplane again rapidly approaches zero yawing velocity without overshoot. It should be noted, however, that the airplane when in equilibrium is at some small right roll angle because of a small right aileron deflection being held by the automatic system in order to cancel the relatively large left directional out-of-trim moments.

In order to evaluate the automatic system under operational conditions, a maneuver was performed in which the pilot manually performs a heading change and levels the airplane on the desired new heading. It was then desired to release the controls and let the automatic system fly the airplane on the desired new heading. A time history of this maneuver without the aileron force switches is shown in figure 18. During this type of maneuver performed without the aileron force switches as part of the automatic system, it was found that the airplane would wander off in the direction of the recovery and settle down on a heading displaced a few degrees from that desired. Therefore, in order to hold the desired new heading, the pilot had to hold a force equal to the preloaded spring breakout force in order to compensate for the centering-spring deflection introduced by the automatic control during the steady-turn portion of the maneuver. The airplane would then remain out of trim as long as the heading was held constant since no moment was exerted on the gyro to close one or the other contacts as would be necessary for the system to retrim itself. This characteristic was considered undesirable since a minimum force of about 4 pounds is required to overpower the control. This condition, of course, also prevails when it is desired that a given heading be held during precision navigation.



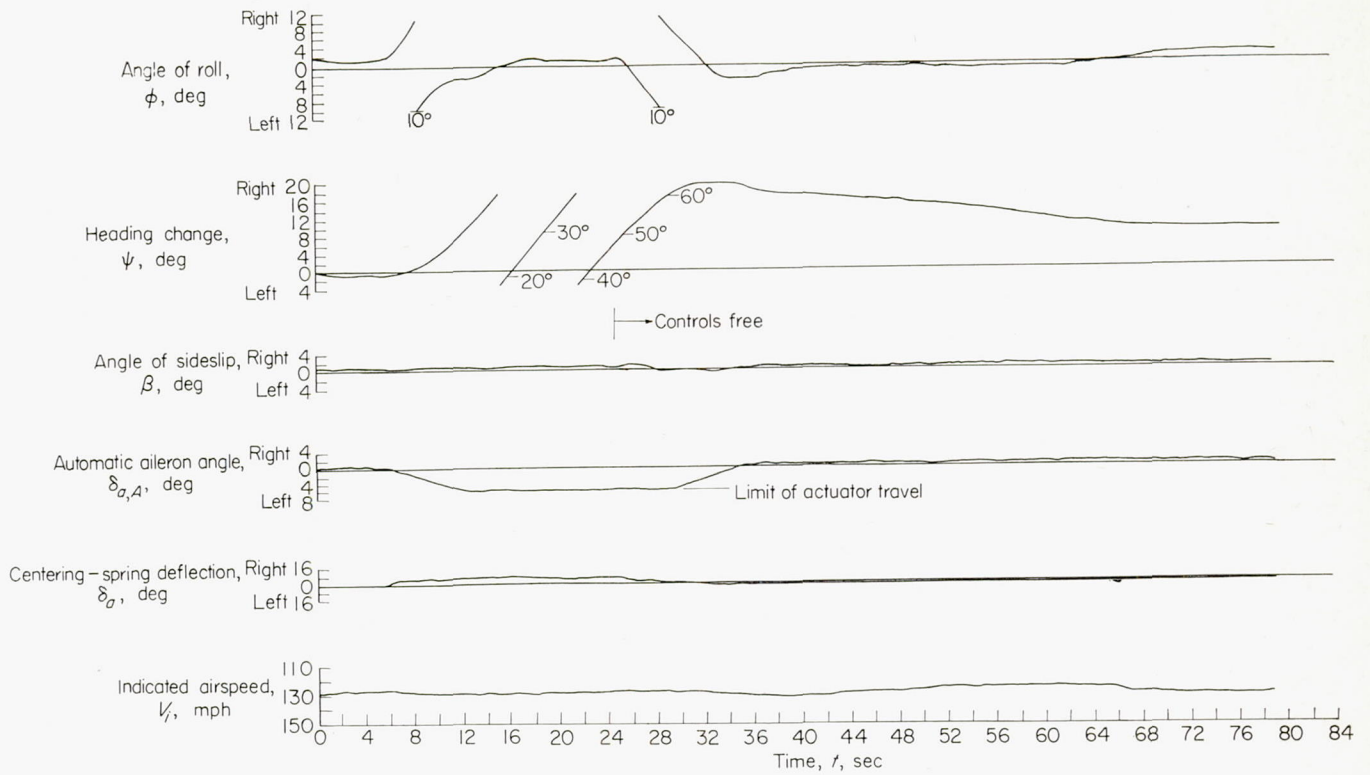

FIGURE 16.—Time history of the automatic-control airplane motions. Pilot performs a 45° heading change and releases the controls from about a 20° right roll angle.  $V_i=135$  mph;  $h_i=5,000$  feet.

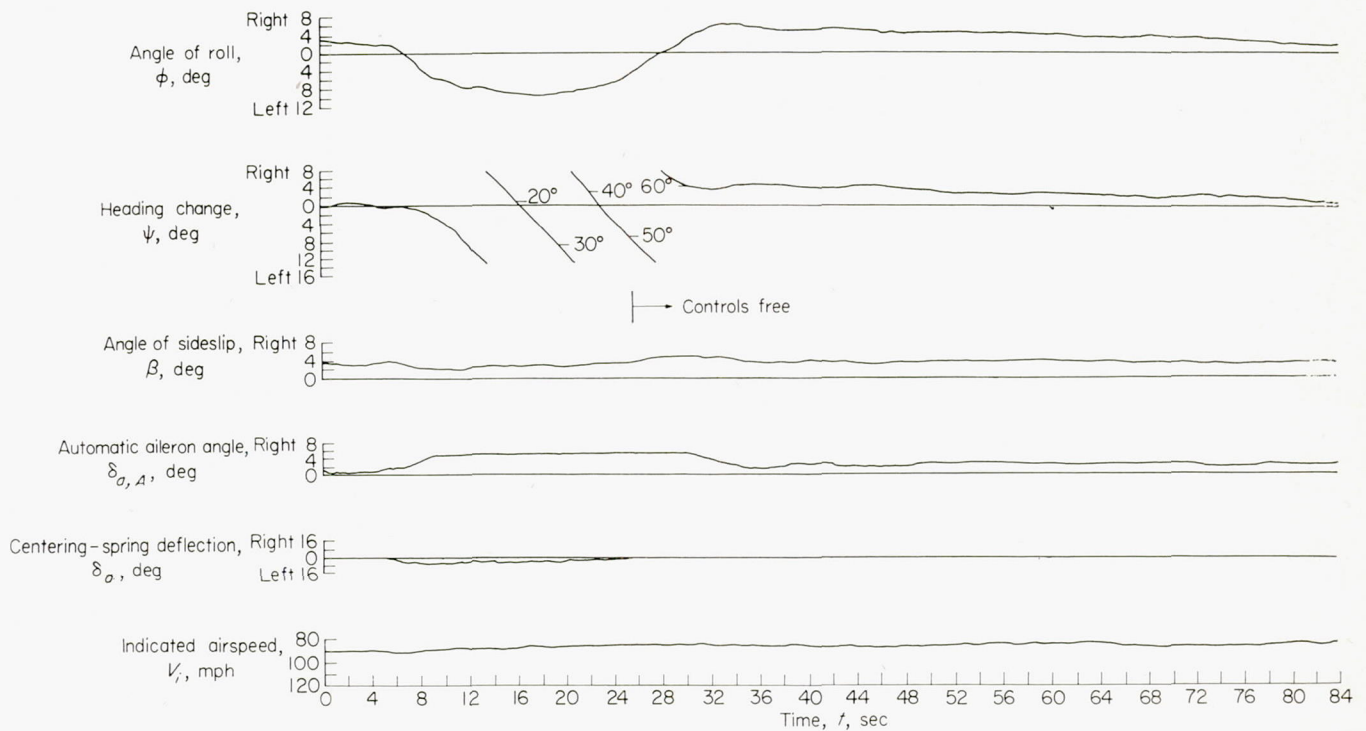

FIGURE 17.—Time history of the automatic-control airplane motions. Pilot performs a 45° heading change and releases the controls from a left roll angle with the airplane out of trim to the left.  $V_i=90$  mph;  $h_i=5,000$  feet.



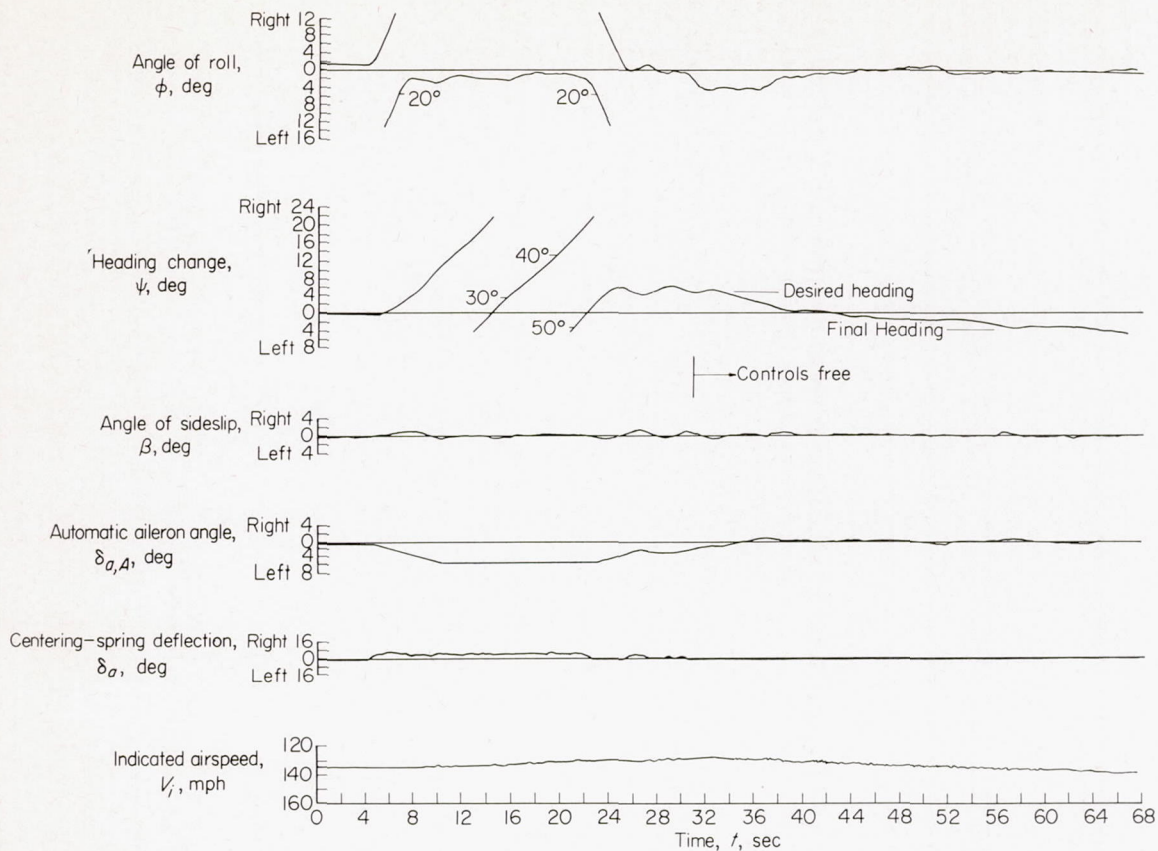

FIGURE 18.—Time history of the automatic-control airplane motions. Pilot performs a  $45^\circ$  heading change, levels airplane on desired new course, and releases controls. Aileron force switches not connected;  $V_i = 135$  mph;  $h_i = 5,000$  feet.

Consequently, the force-sensitive switches described earlier were added to the automatic control. Figure 19 is a repeat of the aforementioned maneuver at 137 mph at a 7,000-foot altitude with the airplane out of trim to the right. With the modified system (fig. 19) the pilot is able to set his airplane on a desired heading, hold this heading momentarily until the automatic system stabilizes, as indicated to the pilot by the reduction of control-wheel force to zero, and then release the control wheel. Subsequent small heading corrections can then be made by applying a relatively light wheel force in the desired direction, thus flying the airplane through the automatic control. Upon completion of the correction, the wheel may again be released. By steering the airplane through the force switches, heading changes at a controlled rate of  $3^\circ$  per second may be performed.

The automatic control during smooth air was found to maintain a heading within about  $2^\circ$  over a 5-minute period with control wheel free. During a similar test the normal airplane, even when trimmed, diverged directionally about  $70^\circ$  or more.

Figures 20 and 21 show the automatically controlled airplane flying on a steady heading while directionally out of

trim to the left and right, respectively, because of an air-speed decrease to 90 mph and an increase to 150 mph from a trim speed of 135 mph. These records were made in moderately rough air with pilot controls free. The directional motions of the airplane shown in figure 20 are due primarily to moderate-to-heavy turbulence during this test. The automatic control is seen to be very effective in correcting for the random disturbances and holds a fairly good mean heading. The airplane during these tests shows no unstable tendencies. Figures 20 and 21 should be compared with figures 14 and 15 for similar out-of-trim conditions with the basic airplane.

#### PILOTS' OPINION OF AUTOMATIC SYSTEM

Four pilots employed by the National Advisory Committee for Aeronautics have flown the test airplane and were questioned on these four main characteristics regarding the system performance: (1) effectiveness of the automatic system in coping with lateral out-of-trim moments, (2) effectiveness of the system during turbulent-air operation, (3) suitability of the system for cross-country flight conditions, and (4) aileron force characteristics. These four main characteristics are discussed as follows:



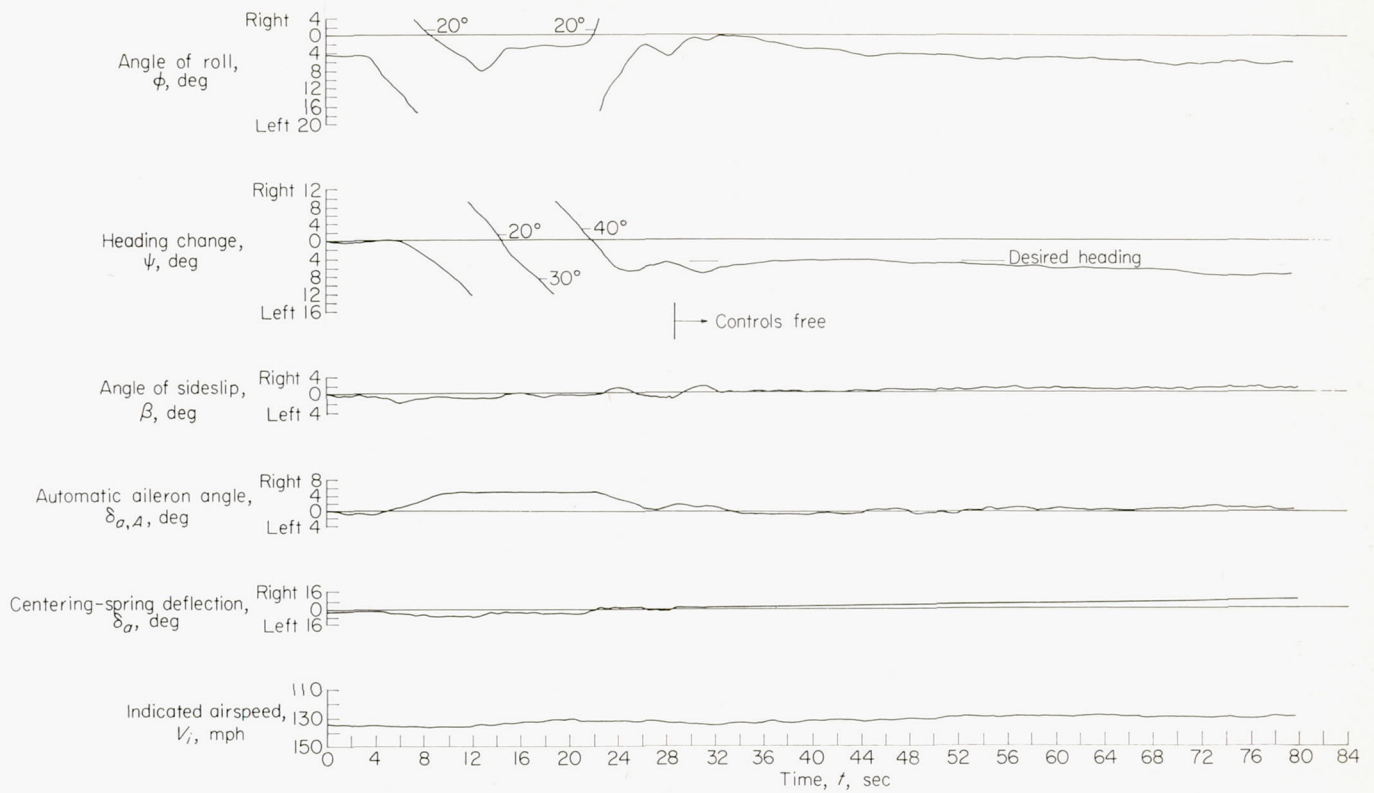

FIGURE 19.—Time history of the automatic-control airplane motions. Pilot performs a 45° heading change, levels airplane on desired new course, and releases controls. Aileron force switches operative;  $V_i=135$  mph;  $h_i=7,000$  feet.

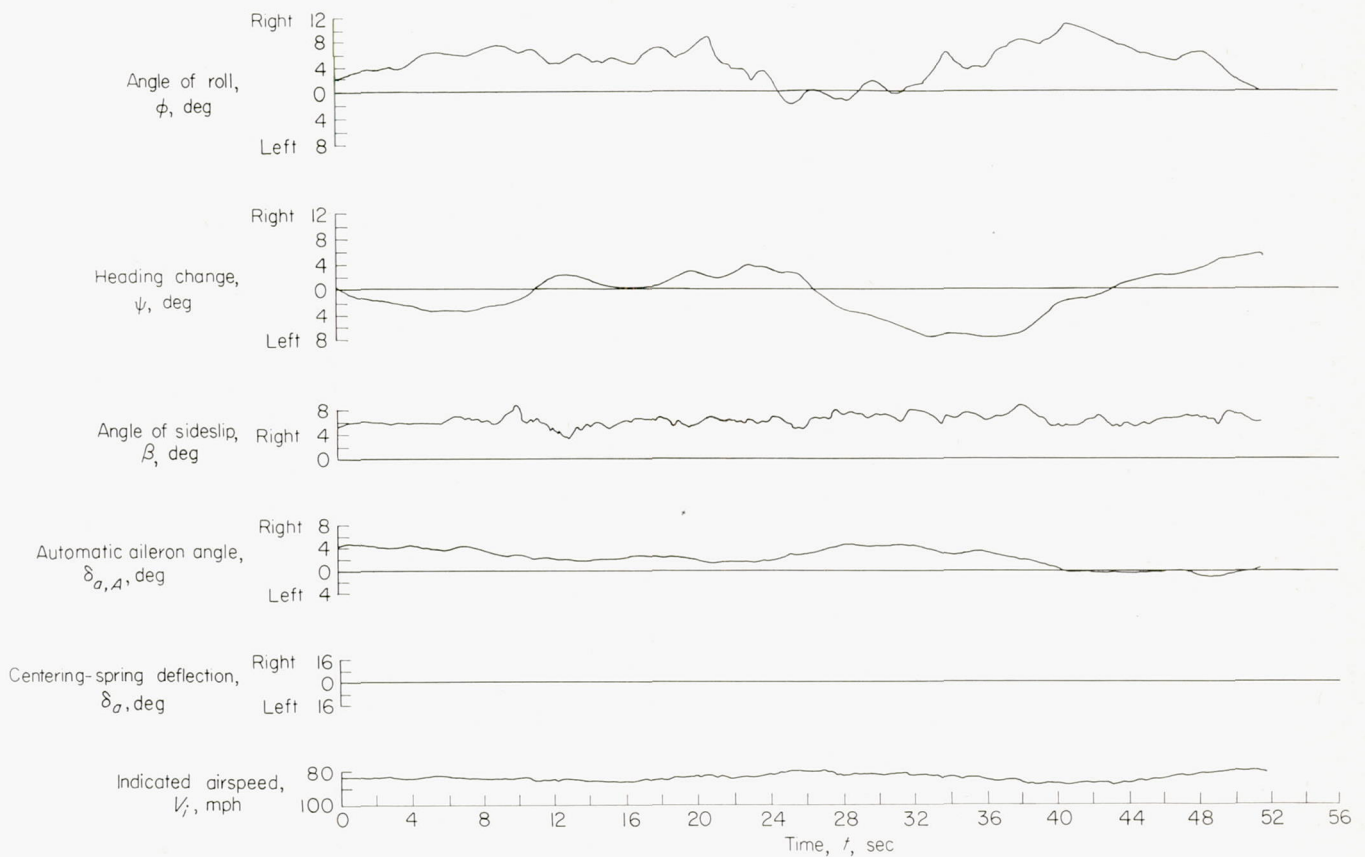

FIGURE 20.—Time history of the automatic-control airplane motions. Pilot releases controls from level flight with airplane out of trim to the left.  $V_i=90$  mph;  $h_i=5,000$  feet.



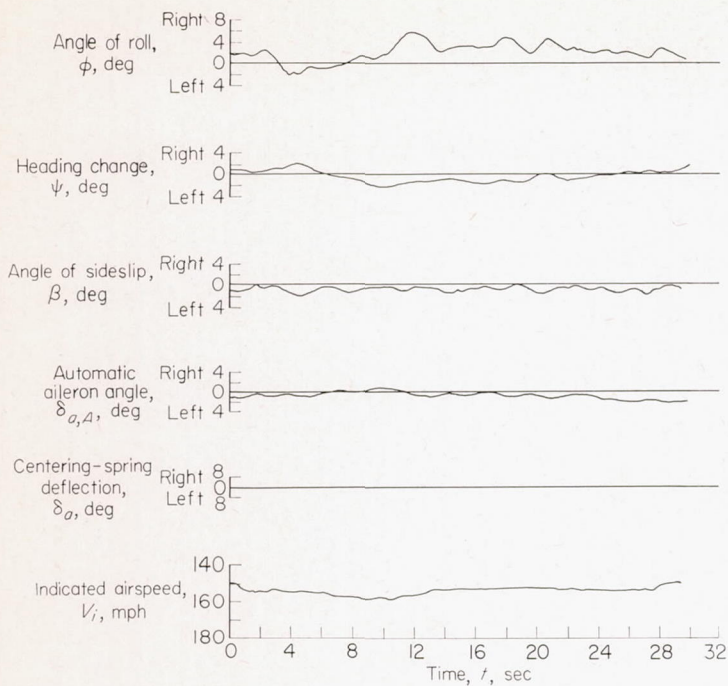

FIGURE 21.—Time history of the automatic-control airplane motions. Pilot releases controls from level flight with airplane out of trim to the right.  $V_i=150$  mph;  $h_i=5,000$  feet.

(1) All four pilots are of the opinion that the automatic system is definitely an asset to the basic airplane in handling directional out-of-trim moments that would otherwise cause the basic airplane to diverge. The airplane with controls free will fly indefinitely in a safe attitude independent of air-speed or load changes that would cause directional trim changes.

(2) During turbulent-air operation, the automatic system prevents the airplane from diverging because of gust disturbances. The system also helps the airplane hold a more constant heading and reduces random airplane gyrations in roll and yaw, thus resulting in a more comfortable ride with reduced pilot effort as compared with that of the basic airplane.

(3) The automatic system is intended primarily as a pilot's aid during navigation with limited or zero visibility, such as may inadvertently be encountered in cross-country flight. Pilots' opinion of the automatic system corresponds to the data presented previously which show that the system will maintain the airplane in equilibrium for an indefinite period of time and allow the pilot to concentrate on navigational problems without constantly monitoring the airplane attitude.

Addition of the force-sensitive switches was regarded as a worthy addition to the system. Turn rates available by flying through the force switches were sufficient to enable the pilot to fly a radio-range leg during simulated instrument flight.

In conclusion, the automatic system is considered desirable when operating under limited visibility conditions. During visual-contact flight, the automatic system will likewise be helpful in allowing the pilot to relax without concern as to the airplane attitude or to the heading changing excessively.

(4) Aileron force characteristics due to the preloaded springs were considered objectionable during visual-contact sport flying and during take-off and landing where large rapid aileron deflections were required, especially during gusty conditions. It is recommended that the automatic system be disengaged during landing and take-off since the airplane must be under complete pilot control at these times and the automatic trim control system is not intended to perform any useful function during take-off and landing. A manual engage knob as used in this device that physically disengages the preloaded springs from the aileron cables was found desirable. The need for applying steady aileron force to overcome the spring preload in a steady turn was unusual and was not considered desirable by the test pilots, although no strong objections were raised to this feature. Nonpilots with limited flight experience, on the other hand, considered this characteristic desirable. The aileron force gradient with deflection at cruising speed was considered tolerable, although not as desirable for maneuvering as the lighter force gradient of the original airplane.

## CONCLUSIONS

The present investigation of the effectiveness of an automatic aileron trim control device to augment the apparent spiral stability of a personal airplane and thus prevent spiral divergence has led to the following conclusions:

1. The automatic aileron trim control will maintain the airplane in a safe attitude for an indefinite period of time over the speed range investigated (90 mph to 150 mph) without manually retrimming the airplane.

2. During turbulent-air operation, the automatic control helps the airplane hold a more constant heading with less pilot effort than is required for the basic airplane.

3. An automatic control such as that used in this investigation provides considerable pilot relief and adds to the safety of cross-country flight, particularly during instrument-flight conditions.

4. The increased pilot control forces necessary to overpower the automatic control may be objectionable to the personal-airplane pilot during visual-contact sport flying and especially during take-off and landing. Consequently, a means for rapidly disengaging the automatic control such as that provided was found desirable.

LANGLEY AERONAUTICAL LABORATORY,  
NATIONAL ADVISORY COMMITTEE FOR AERONAUTICS,  
LANGLEY FIELD, VA., *January 4, 1956.*

## REFERENCES

1. Carroll, Thomas, and McAvoy, William H.: *Spiral Tendency in Blind Flying*. NACA TN 314, 1929.
2. McKinney, Marion O., Jr.: *Analysis of Means of Improving the Uncontrolled Lateral Motions of Personal Airplanes*. NACA Rep. 1035, 1951. (Supersedes NACA TN 1997.)
3. Campbell, John P., Hunter, Paul A., Hewes, Donald E., and Whitten, James B.: *Flight Investigation of the Effect of Control Centering Springs on the Apparent Spiral Stability of a Personal-Owner Airplane*. NACA Rep. 1092, 1952. (Supersedes NACA TN 2413.)