

MR March 1944

NATIONAL ADVISORY COMMITTEE FOR AERONAUTICS

WARTIME REPORT

ORIGINALLY ISSUED

March 1944 as
Memorandum Report

MEASUREMENTS OF FLYING QUALITIES OF

A CURTISS SB2C-1 AIRPLANE

(NO. 00014)

By W. H. Phillips, W. C. Williams,
and H. H. Hoover

Langley Memorial Aeronautical Laboratory
Langley Field, Va.



WASHINGTON

NACA WARTIME REPORTS are reprints of papers originally issued to provide rapid distribution of advance research results to an authorized group requiring them for the war effort. They were previously held under a security status but are now unclassified. Some of these reports were not technically edited. All have been reproduced without change in order to expedite general distribution.

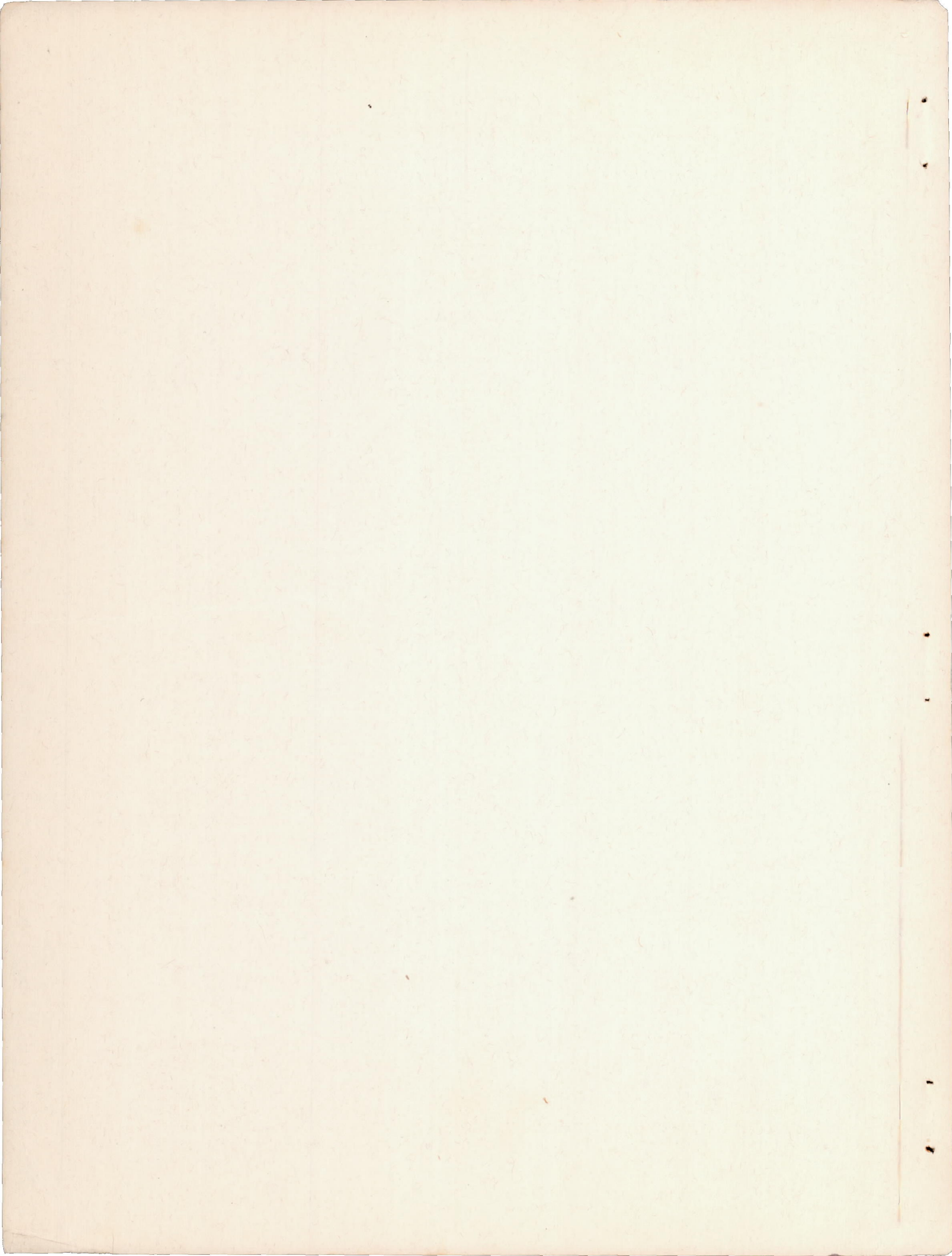

NATIONAL ADVISORY COMMITTEE FOR AERONAUTICS

MEMORANDUM REPORT

for the

Bureau of Aeronautics, Navy Department

MEASUREMENTS OF FLYING QUALITIES OF

A CURTISS SB2C-1 AIRPLANE

(NO. 00014)

By W. H. Phillips, W. C. Williams,

and H. H. Hoover

INTRODUCTION

At the request of the Bureau of Aeronautics, Navy Department, the flying qualities of a Curtiss SB2C-1 airplane (No. 00014) have been measured. The tests were conducted at Langley Field, Va., between April 27 and May 22, 1943. In addition to complete tests of the airplane in its original condition, tests were made to determine the effect of a bobweight in the elevator system, and the effect of seals in the aileron gaps. Fourteen flights and approximately 18 hours of flying time were required to complete the tests. Measurements of structural loads were made on two other Curtiss SB2C-1 airplanes, Nos. 00056 and 00140. Certain additional information with regard to the flying qualities that was obtained in these investigations is also presented.

DESCRIPTION OF THE CURTISS SB2C-1 AIRPLANE

The SB2C-1 airplane is a two-place, single-engine, low-wing cantilever monoplane with retractable landing gear and partial-span split flaps (figs. 1 to 4). All data given in this report apply to airplane No. 00014 unless otherwise noted. Airplane No. 00056 did not differ from No. 00014 except in minor details of the

canopy and radio installation. Airplane No. 00140 was equipped with a more rigid wing and stabilizer. The nose on the elevator balance of No. 00140 was modified to have a smaller radius, and for some flights a rudder with twice the normal number of ribs was used. The general specifications of the airplane follow:

Name and type Curtiss SB2C-1
(Bureau of Aeronautics No. 00014)

Engine Curtiss-Wright R-2600-8
Rated:

Take-off 1700 hp at S.L.
Military (low blower) 1700 hp S.L. to 3000 ft
Normal (low blower) 1500 hp S.L. to 6700 ft
Normal (high blower) 1350 hp 6700 to 13,000 ft

Gear ratio 16:9

Propeller:

Diameter 12 ft
Number of blades 3

Fuel capacity 290 gal

Oil capacity 25 gal

Empty weight 10,114 lb

Normal gross weight 12,677 lb

Wing loading (normal gross weight) 30.1 lb/sq ft

Power loading (normal gross weight) 7.46 lb/hp

Over-all height (thrust axis level) 16 ft 11 in.

Over-all length 36 ft 8 in.

Wing:

Span 49 ft $8\frac{5}{8}$ in.

Area (including ailerons and 21.6 sq ft fuselage) 422 sq ft

Airfoil section:

Root NACA 23017

Tip NACA 23009

Aspect ratio 5.87

Mean aerodynamic chord 109.3 in.

Distance behind leading edge of wing

at root 0.34 in.

Taper ratio 2.32 to 1

Dihedral (leading edge of wing) 6.0°

Incidence $1\frac{1}{2}^\circ$ at root, $\frac{1}{2}^\circ$ at tip

Sweepback (leading edge of wing) 2°

Wing flaps (split flaps on upper and lower surfaces) 52.2 sq ft

Maximum deflection (landing) 0° up, 60° down

Maximum deflection (diving) 45° up, 45° down

Slat (extends with landing gear) ..Covers 29.4 percent span inboard of rounded tip

Horizontal tail:

Span	19 ft $\frac{1}{2}$ in.
Total horizontal-tail area including area through fuselage	107.4 sq ft
Elevator balance area forward of hinge line	10.08 sq ft
Elevator area aft of hinge line including trim tab	27.8 sq ft
Trim tab area (left side)	1.42 sq ft
Balance tab (right side) locked	
Horizontal-tail section	Modified NACA 0009-64
Stabilizer incidence	3.0°
Elevator fabric tension ^a (airplane 00014) ..	4.9 lb/in.
(airplane 00140) ..	3.1 lb/in.

Vertical tail surfaces:

Total vertical-tail area	45.7 sq ft
Rudder balance area forward of hinge line	3.0 sq ft
Rudder area aft hinge line including trim tab	19.2 sq ft
Rudder trim tab area	1.42 sq ft
Balance tab locked	

Ailerons:

Aileron area aft hinge line (each aileron).	13.7 sq ft
Aileron chord, percent wing chord	24
Aileron balance chord, percent aileron chord	31.7
Inboard end of aileron to center line of airplane	0.58 b/2
Outboard end of aileron to center line of airplane	0.93 b/2
Aileron tab area (left side trim, right side balance) each	0.62 sq ft

^aThe elevator fabric tension was measured quantitatively with a special instrument. A tension of 3 pounds per inch is considered normally tight.

The relation between control deflections and stick and rudder pedal positions with no load on the surfaces is given in figure 5. Elevator and rudder angles are given with respect to the thrust axis throughout this report. Tab settings given on the figures refer to trim tab angles, not cockpit-indicator readings. Sections of the horizontal tail, vertical tail, and aileron installation are given in figures 6, 7, and 8, respectively. The

lettered sections given on these figures correspond to the lettered sections given on figure 4.

The product of the span and chord squared, on which hinge-moment coefficients for the various control surfaces are based, is as follows:

Elevator.....	48
Aileron (each).....	22.2
Rudder.....	44.5

The friction of the control system was as follows:

1. Elevator-control system ± 5 pounds
2. Aileron-control system ± 4 pounds
3. Rudder-control system - Friction varied with rudder position (See fig. 9.) At large deflection, the force required to move the rudder on the ground was due in part to springiness in the control system.

The elevator and aileron friction was about the maximum allowable under Requirement C-6 of reference 1. The rudder friction at most rudder positions exceeded that allowable under the above requirement.

Figure 10 gives a drawing of the bobweight in the elevator-control system as used in the longitudinal stability and control tests at the more rearward center-of-gravity positions.

INSTRUMENTATION

Standard NACA photographically recording instruments were used to measure the various quantities necessary to determine the flying qualities of the subject airplane. The records were synchronized by means of a timer. The instruments used and the quantities measured follow:

Recording instrument	Quantity measured
Airspeed recorder	Indicated airspeed
Three-component accelerometer	Normal, longitudinal, and transverse acceleration
Roll turn meter	Rolling velocity
Pitch turn meter	Pitching velocity
Inclinometer	Angle of bank
Yaw-angle recorder	Sideslip angle
Stick-force recorder	Aileron and elevator stick force
Rudder-force recorder	Rudder-pedal force
Control-position recorder	Rudder, elevator, and aileron position (measured at the surface)
Timer	Time

The yaw vane used with the yaw-angle recorder was mounted 1 chord length ahead of the left wing tip. Indicated airspeed was measured with a swiveling static head and a shielded total head mounted 1 chord length ahead of the right wing tip. The airspeed used throughout this report, called correct service indicated airspeed, is defined by the formula:

$$V_i = 45.08 f_o \sqrt{q_c}$$

where

- V_i correct service indicated airspeed, miles per hour
- f_o standard sea-level compressibility correction factor
- q_c measured difference between total and static pressures corrected for pitot-static position error, inches of water

(Note that this indicated airspeed corresponds to the reading of a pilot's meter connected to a pitot-static installation that has no position error.)

TESTS

The airplane was flown at center-of-gravity locations ranging from 23.8 to 31.3 percent M.A.C. The gross weight varied from 12,000 to 12,700 pounds. There was some forward shift of the center of gravity with gas consumption. The center-of-gravity positions were corrected for this effect.

The flight conditions used in the tests are defined below.

Condition	Bomb bay and vision doors	Flaps	Landing gear	Front hood	Rear hood	Cowl flaps	Rpm	Manifold pressure in. Hg at 5000 ft
Gliding	Closed	Up	Up	Closed	Closed	Closed	Power off	Power off
Climbing	Closed	Up	Up	Closed	Closed	Open	2400	38
Landing	Closed	Down	Down	Open	Closed	Closed	Power off	Power off
Approach	Closed	One-half down	Down	Open	Closed	Open	2400	21
Wave-off	Closed	Down	Down	Open	Closed	Open	2400	38
Dive flaps open (Power off)	Open	Dive flaps open	Up	Open	Closed	Closed	Power off	Power off
Dive flaps open (Power on)	Open	Dive flaps open	Up	Open	Closed	Closed	2400	25

In addition to the prescribed tests for the flying-qualities investigation, tests were also made of the longitudinal stability and control with a bobweight requiring a pull force of 11 pounds on the stick. Details of the bobweight installation are given in figure 10.

RESULTS AND DISCUSSION

The results are presented and analyzed in the order given in reference 2 with reference made to the specific requirements of reference 1.

I. Longitudinal Stability and Control

I-A. Characteristics of uncontrolled longitudinal motion

The characteristics of the uncontrolled longitudinal motion were investigated at various speeds through the speed range in the climbing and gliding condition. In these tests the airplane was trimmed at the given speed and continuous records were taken while the pilot abruptly deflected and released the elevator. No oscillation ensued in either condition at any speed tested. Typical time histories of this maneuver are given in figure 11. It should be noted from this figure that although the elevator did not oscillate, it did not return to trim because of the friction force.

I-B. Characteristics of elevator control in steady flight

The characteristics of elevator control in steady flight, at speeds ranging from the stall to moderately high speeds, were obtained by measuring the elevator angle and force required to trim with at least two center-of-gravity positions in each of the various conditions of flight. The following table lists the flight conditions tested, the center-of-gravity position, whether or not the bobweight was installed and the figures in which the experimental data are presented.

Flight condition	Center-of-gravity position	Control system	Figure no.
Gliding	24.55 and 28.0	Normal	12
Gliding	31.3	Bobweight	12
Climbing	24.9 and 28.54	Normal	13
Climbing	31.6	Bobweight	13
Dive flaps open (power on)	24.4	Normal	14(a)
Dive flaps open (power on)	29.35	Bobweight	14(a)
Dive flaps open (power off)	24.4	Normal	14(b)
Dive flaps open (power off)	29.35	Bobweight	14(b)
Landing	23.7 and 26.8	Normal	14(c)
Approach	24.7 and 28.0	Normal	15(a)
Wave-off	24.0, 24.3, and 27.8	Normal	15(b)

The directional trim characteristics as well as the longitudinal stability data are included in the foregoing figures.

The static longitudinal stability data were evaluated to determine the stick-fixed and stick-free neutral points by the following methods. Figures were prepared showing the variation of elevator angle δ_e with the airplane lift coefficient C_L for each center-of-gravity position in various conditions of flight. Typical figures of this type are included (figs. 16 and 17) in order to illustrate the degree of accuracy of the data. The slopes of these curves were measured at representative values of the lift coefficient and were plotted as functions of center-of-gravity position in figure 18. The stick-fixed neutral-stability points are found from this figure as the center-of-gravity position at which the slope $d\delta_e/dC_L = 0$. Figures were also prepared which showed the variation of elevator force divided by dynamic pressure F/q with airplane lift coefficient. The slopes

of these curves were also measured at representative lift coefficients and plotted as functions of center-of-gravity position on figure 18. The stick-free neutral point is defined as the center-of-gravity position at which the

slope $\frac{dF}{dC_L} = 0$. Accurate measurements of the elevator-

stick forces, however, were difficult because of the friction force in the elevator-control system that caused a force on the grip of the stick of about 5 pounds when the stick was moved slowly in either direction. This source of error must be kept in mind when interpreting the results of the elevator-stick-force measurements.

The following facts regarding the static longitudinal stability of the SB2C-1 airplane are shown by figures 12 to 18.

(a) The stick-fixed neutral-stability point in the gliding condition was between 33 and 34 percent of the mean aerodynamic chord. Application of rated power (climbing condition) caused a large destabilizing effect, especially at speeds near that used for best climb. In the climbing condition at an airplane lift coefficient of 1.0, the stick-fixed neutral point was at 26 percent of the mean aerodynamic chord.

(b) The stick-fixed neutral-stability point in the landing condition was at about 31 percent of the mean aerodynamic chord. Application of power with flaps down as with flaps up caused a large destabilizing effect as shown by the curves for the approach and wave-off condition.

(c) With the dive flaps extended, power off, the static stability was almost the same as in the gliding condition. The most unstable condition encountered in the tests was with dive flaps extended, power on, at speeds near the stall. At higher speeds in this condition, the stability was almost the same as in the climbing condition.

(d) Requirement D-6 of reference 1 specifies that the stick-fixed stability should be such that in the gliding and landing condition, the movement of the top of the stick shall not be less than 4 inches in trimming from the maximum level-flight

speed to stalling speed. The present data show that the SB2C-1 airplane will meet this requirement only when the center of gravity is located forward of 24.5 percent mean aerodynamic chord in the gliding condition and forward of 25-percent mean aerodynamic chord in the landing condition. Requirement D-6 (reference 1) also specifies that there shall not be less than 1-inch stick motion in going from the speed for minimum power to the stall in either the gliding or landing condition. This latter requirement will be met by the SB2C-1 airplane when the center of gravity is forward of 29 percent mean aerodynamic chord in the gliding condition and 28.3 percent mean aerodynamic chord in the landing condition.

(e) The stability with stick free was less than with stick fixed. The stick-free neutral point was between 3 and 4 percent of the mean aerodynamic chord forward of the stick-fixed neutral point in most flight conditions.

(f) The elevator control was such that it was possible to maintain steady flight at the minimum and maximum speeds required of the airplane.

The relatively large amount of friction in the elevator-control system prevented the stick from returning to its trim position when displaced. The friction was also believed to be responsible for an impression of instability obtained by the pilots when they attempted to maintain constant-speed flight. A detailed time history of the stick force and movement during a run made in airplane No. 00140 in which the pilot attempted to maintain a constant speed of 207 miles per hour is shown in figure 19. Continual variation of the stick force, elevator angle, and normal acceleration is indicated by this figure, though the center-of-gravity location was sufficiently far forward to provide stick-fixed stability. The reason for the difficulty experienced by the pilot in holding a specified speed was believed to be a combined effect of flexibility in the control system and friction in the elevator hinge. Small movements of the stick could be made without moving the elevator, but when the elevator started to move it would overshoot the desired position. The exact elevator angle required to trim at 207 miles per hour was therefore never attained and continual adjustments had to be made. In order to verify that the airplane possessed stick-fixed stability, the

pilot released the stick at the end of the record shown in figure 19. The airplane settled down to a speed of 215 miles per hour and this speed remained constant for several minutes of flight. During this time the elevator was held fixed by the friction in the system.

The pilots considered the effect of the friction on the longitudinal characteristics to be undesirable.

The longitudinal stability of airplane No. 00014 was not investigated at indicated airspeeds above about 320 miles per hour, but several power-off dives were made in airplanes 00056 and 00140 at indicated speeds up to 420 miles per hour and at Mach numbers up to 0.625. The stick-fixed and stick-free stability characteristics of the three airplanes tested differed to some extent at low speeds. At high speeds, considerable difference was measured between the stick-fixed stability exhibited by airplanes 00056 and 00140. The characteristics of airplane No. 00140 were determined by recording the elevator angles required in steady flight at 208 miles per hour and the variation of elevator angle throughout dives to various speeds. On airplane No. 00056, the same information was obtained except that the elevator angles in the dives were not recorded until just before the dive pull-outs. The variation of elevator angle with speed during the dives of airplane 00140 is plotted in figure 20. The low- and high-speed elevator angles obtained on airplane 00056 are also shown in this figure. It appears that airplane 00140 became statically unstable with stick fixed above about 320 miles per hour, whereas airplane 00056 remained stable to the highest speed tested. With the center-of-gravity positions used, both airplanes had about the same degree of stability at low Mach numbers. The stick force in the dives of airplane 00140 varied from about 20 pounds push at the start of the dive to zero just before the pull-out. This force variation indicates stick-free static instability. The records during the dives were not smooth and considerable variation of normal acceleration occurred, probably because of the effects of friction discussed previously.

The characteristics of airplanes 00056 and 00140 at high speeds are outlined in this report to extend the speed range of the tests of airplane 00014. Several differences in the stability characteristics

of the three airplanes, not completely reported herein, were measured in the range of normal flight speeds.

I-C. Characteristics of the elevator control in accelerated flight

The characteristics of the elevator control in accelerated flight were determined at moderate airspeeds from measurements made in rapid turns at several center-of-gravity positions. The bobweight was installed for the most rearward center of gravity tested. Both stalled and unstalled turns were made at several speeds. Time histories of typical stalled turns are given on figures 21 and 22. A time history of a typical steady turn such as was used in obtaining the data is given in figure 23. The variation of elevator angle with lift coefficient, as measured in steady, unstalled turns, is presented in figure 24 for the three center-of-gravity positions tested. From these same turns, the variation of elevator stick force with normal acceleration was determined and is given in figure 25 for the three center-of-gravity positions. From figure 24 the slope $d\delta_e/dC_L$ was determined for the center-of-gravity positions tested and plotted on figure 26 as a function of center-of-gravity position. From figure 25, the stick force per g was determined and also plotted on figure 26 as a function of center-of-gravity position. From the data presented in figures 21 to 26, the following conclusions can be made regarding the elevator control of the SB2C-1 airplane in accelerated flight:

(a) By use of the elevator control alone, it was possible to develop the maximum lift coefficient of the airplane in maneuvers (figs. 21 and 22). No attempt was made to develop the allowable load factor.

(b) The variation of elevator angle with lift coefficient was a smooth curve having a stable slope for all center-of-gravity positions (fig. 24).

(c) The SB2C-1 will satisfy the requirement of reference 2 that the slope of the elevator-angle curve should be such that not less than 4 inches of rearward stick movement is required to change angle of attack from C_L of 0.2 to C_{Lmax} in the maneuvering condition of flight only when the center of

gravity if forward of 24.6 percent mean aerodynamic chord (fig. 24).

(d) The variation of elevator force with acceleration was linear, within the scatter of the experimental data (fig. 25).

(e) The SB2C-1 airplane will have the desired stick force per g, (3 to 8 pounds per g, Requirement D-4, reference 1) at center-of-gravity positions from 28. to 30 percent mean aerodynamic chord without the bobweight and from 32. to 34 percent mean aerodynamic chord with the bobweight (fig. 26).

From the data presented above and from the static longitudinal stability data, it was possible to determine the hinge-moment coefficients, Ch_d and Ch_δ of the SB2C-1 elevator. The values were -0.0012 and -0.0033, respectively. These values of hinge-moment coefficient are based on free-stream dynamic pressure and a value of 48 feet cubed for the product of elevator span and chord squared.

The characteristics of airplanes 00056 and 00140 in accelerated flight at high speeds were determined in pull-outs from power-off dives. The stick force per g normal acceleration is plotted as a function of Mach number in figure 27(a) for airplane 00056 and in figure 27(b) for airplane 00140 with two center-of-gravity positions. It will be noted that the stick-force gradient for airplane 00056 shows a tendency to decrease with increasing Mach number. The stick-force gradient for airplane 00140 is considerably greater than that for airplane 00056 even with a more rearward center-of-gravity position. This difference may be due to the modified elevator nose shape. The stick-force gradient again tends to decrease as the Mach number increases, especially with the more rearward center-of-gravity position. Though the stick-force characteristics are plotted against Mach number, it is not implied that compressibility effects were entirely responsible for the observed changes, inasmuch as considerable distortion of the elevator fabric resulting from negative pressure inside the surface was observed to occur at high speeds.

I-D. Characteristics of the elevator control in landing

The characteristics of the elevator control in landing were determined by measuring the elevator deflection required to make a power-off three-point landing. The elevator deflection required to land is plotted as a function of center-of-gravity position in figure 28. A time history of a typical landing is shown in figure 29. From the data obtained in the landing tests, the following can be concluded:

(a) The elevators of the SB2C-1 airplane were sufficiently powerful to perform a three-point landing at the most forward center-of-gravity position tested using only 23° of the available full up-elevator deflection of 35° . It might, therefore, be advantageous to decrease the available up-elevator travel while retaining the same control stick motion, thereby increasing the mechanical advantage of the elevator-control system.

(b) The elevator forces of the SB2C-1 airplane in landing did not exceed the allowable force of 35 pounds (reference 2) at the center-of-gravity positions tested.

I-E. Characteristics of the elevator control in take-off

In one test made to record the airspeed at which the tail could be raised, it was found that the tail started to rise at an airspeed of 52 miles per hour. For this run, the flight conditions were flaps up, landing gear down, 38 inches mercury, 2400 rpm, center of gravity at 28.4 percent of the mean aerodynamic chord.

According to pilots' observations, the elevator was adequate to raise the tail or adjust the attitude angle during take-off after slightly more than half take-off speed was reached. Stick forces, however, were heavy.

I-F. Trim changes due to power and flaps

The trim changes caused by various changes in configuration and power were measured at a speed of 120 miles per hour with the center of gravity at 23.7 percent of the mean aerodynamic chord with landing gear down,

or 24.2 percent, gear up. For these tests, the airplane was trimmed in the climbing condition with an elevator tab setting of 0.2° tail heavy and a rudder tab setting of 10.8° nose right. These tab settings were held constant while the trim forces for the various configurations and power were measured. The results of these tests are given in table I. It can be seen by inspection of this table that the changes in elevator trim forces are within the value of 35 pounds specified by both references 1 and 2. As noted in the following discussion, however, trim changes exceeding this limit might be obtained with other elevator trim tab settings.

I-G. Characteristics of the longitudinal trimming device

The power of the elevator trim tabs was determined in three flight conditions (climbing, wave-off, and landing) by measuring the stick forces at various speeds with two trim tab deflections. The results of these tests are given in figures 30 and 31. The data were evaluated to obtain the force per degree trim tab change as a function of speed (fig. 32). The change in elevator hinge-moment coefficient per degree change in trim-tab angles was calculated and is given as a function of speed in figure 33. The hinge-moment coefficients are based on free-stream dynamic pressure and on the same value of the product of the span and chord squared as used in section I-C.

From the foregoing curves, the following conclusions may be shown:

(a) The power of the elevator trim tab was adequate to reduce the elevator force to zero throughout the speed range in all flight conditions except in the landing condition at speeds below 95 miles per hour.

(b) The power of the elevator trim tabs was only one-third as great in the landing condition as in the wave-off condition. Therefore, if the airplane were trimmed full-tail heavy for a landing, and then rated power were applied for a wave-off, the push forces required for trim would become excessive as the speed increased. This characteristic is shown in figure 15(b) and in figure 31(b).

Table I, however, indicates that trim changes due to power with flaps down are not excessive with the tab near neutral.

Considerable backlash existed between the handwheel in the cockpit and the trim tab. This backlash occurred between the handwheel and the irreversible mechanism on the tab control. It did not, therefore, cause play in the trim tabs. Because of this characteristic, however, it was difficult to obtain accurate trim tab settings in the tests. The trim tab would, however, retain a given setting unless changed manually.

II. Requirements for Lateral Stability and Control

II-A. Characteristics of uncontrolled lateral and directional motion

The characteristics of the uncontrolled lateral and directional motion were determined in the speed range from 100 to 300 miles per hour for the gliding and climbing condition and from 90 to 130 miles per hour in the landing condition. In these tests, the airplane was trimmed for laterally level flight and continuous records were taken while the pilot abruptly deflected the rudder then released all controls. Typical time histories of this maneuver are given in figures 34 and 35. The variation of the period and number of cycles to damp to half amplitude with indicated airspeed for the flight conditions tested is given in figure 36. Inspection of this figure shows that the oscillations damped to half amplitude within two cycles in all conditions tested. The amplitude of the sideslip angle variation in these tests was between 2° and 10° . For these amplitudes, therefore, the requirements of reference 1 were satisfied. The pilot noted, however, that in some runs at high speed the lateral oscillations appeared to be poorly damped and that a continuous oscillation of small amplitude might exist. As shown in figure 36, the damping of the oscillations was becoming poorer as the speed increased.

In the dives of airplane 00140, continuous lateral oscillations of amplitudes between 0.2° and 0.7° were observed in records taken in all the dives at speeds ranging from 160 to 400 miles per hour. The rudder was held fixed by the pilot in these dives, but it is possible that a small motion of the rudder might have occurred due to flexibility in the control system. From these

records, it was possible to extend the measurements of the period of the lateral oscillation to 390 miles per hour, as shown in figure 36. The small amplitude lateral oscillations were noticeable to the pilot, especially at high speeds.

The pilot attempted to obtain short-period aileron oscillations by abruptly deflecting the ailerons and then releasing all controls, but there was no ensuing oscillation of the aileron itself. Typical records of this maneuver are given in figure 37.

The ailerons did not return to trim at 200 miles per hour because of the friction force.

II-B. Aileron-control characteristics (rudder fixed)

The aileron-control characteristics (rudder fixed) were measured in abrupt aileron rolls in the landing condition and in the clean condition with power for level flight. Aileron rolls were made in the landing condition at approximately 85 and 105 miles per hour indicated airspeed. Aileron rolls were made in the clean condition at approximately 50-mile-per-hour increments from 100 to 300 miles per hour indicated airspeed. Duplicate tests were made for the unsealed and sealed aileron (fig. 8). Airplane 00014 had unsealed ailerons at the start of the tests. The seals used were of the type that has since been adopted for production models of this airplane.

Figure 38 gives time histories of typical aileron rolls. The data obtained from the aileron rolls were evaluated to determine the variation of aileron effectiveness $pb/2V$ and change in aileron stick force with change in total aileron angle. These data are presented in figures 39 to 42. Figures 39 and 40 give data for the clean condition of flight with the aileron unsealed and sealed, respectively. Figures 41 and 42 pertain to aileron rolls made in the landing condition, ailerons unsealed and sealed, respectively. From these data, it was possible to determine the helix angle $pb/2V$, total aileron deflection, and rolling velocity obtainable with any stick force through the speed range of the tests. Figure 43 gives values of these quantities obtainable with a 30-pound stick force as a function of speed. The rolling velocity in this figure is corrected to 10,000 feet altitude.

The data obtained in the tests reveal the following facts about the aileron-control characteristics of the SB2C-1 airplane.

1. Throughout the speed range, the maximum rolling velocity obtained in abrupt aileron rolls varied smoothly with aileron deflection.

2. The variation of rolling acceleration with time was in the correct direction following an abrupt aileron deflection and no lag was evident in developing the rolling moment.

3. The effect of the seals was to increase the aileron stick forces slightly at high speeds and increase the effectiveness slightly at low speeds.

4. For both the sealed and unsealed conditions, the aileron effectiveness ($pb/2V$ per degree aileron deflection) at 100 miles per hour was approximately 60 percent of that obtained at 200 miles per hour or more.

5. The aileron effectiveness in the landing condition (flaps and gear down, leading-edge slots open) was greater, at a given speed, than in the clean condition. The aileron stick forces were about the same in both conditions of flight.

6. Because of the loss in effectiveness at low speeds and the heavy stick forces at high speeds, the ailerons fall far short of meeting the minimum Navy requirement (Requirement F-8, reference 1) that specifies a value of $pb/2V$ of 0.08 at speeds between 140 percent of the stalling speed and 80 percent of the maximum level-flight speed, with a 30-pound stick force.

7. The average value of $dC_h/d\delta$ for the left and right ailerons for small deflections was approximately -0.0042 per degree. In this instance, C_h represents the over-all hinge-moment coefficient as affected by deflection and by the response of the airplane in a steady roll. The value of $dC_h/d\delta$ was almost constant through the speed range except at 300 miles per hour, the highest speed tested, where a slight increase was observed. In

order to obtain full deflection with a 30-pound stick force at 202 miles per hour or 0.8 of the maximum level-flight indicated speed, a value of $dC_h/d\delta$ of -0.00195 would be required.

8. The stretch in the aileron-control system in flight was determined by measuring simultaneously the angles of the ailerons and the control stick. The reduction in total aileron angle, due to stretch, was approximately 0.9° per 10 pounds of stick force. The stiffness of the system therefore meets the Navy requirement.

II-C. Yaw due to ailerons

The yaw due to ailerons was measured in the abrupt aileron rolls described above. Maximum sideslip angle was not reached in any of the rolls attempted because the ailerons were not kept deflected for a sufficiently long time (fig. 38). The data presented in figure 38 indicate that the specified maximum angle of sideslip (20° at 110 percent of the minimum speed) will not be exceeded.

II-D. Limits of rolling moment due to sideslip (dihedral effect)

The rolling moment due to sideslip was measured by recording the aileron angle required in steady sideslips. These sideslips were made by slowly deflecting the rudder while using the ailerons and elevator to maintain straight flight at a specified speed. These continuous records were read up at 3-second intervals. The distance between the plotted points may therefore be used to determine the rate at which the sideslip was increased. The sideslip data are presented in figures 44 to 50. In the figures, rudder, elevator, and aileron forces and deflections and the angle of bank are plotted as functions of sideslip angle.

From the foregoing data, the following may be concluded concerning the dihedral effect of the SB2C-1 airplane:

1. There was considerable positive dihedral effect in all conditions as indicated by the amount of aileron deflection required in sideslips.

2. The aileron force in sideslips was in the correct direction in all conditions. At low speeds, however, the forces were of the same order as the 4-pound aileron friction force and, therefore, the control probably would not return to trim when released.

3. The rolling moment due to sideslip was never so great that a reversal of rolling velocity occurred as a result of yaw due to ailerons. There was, however, an appreciable reduction in aileron effectiveness in low-speed aileron rolls (section II-B) which might be attributed to the large positive dihedral effect.

II-E. Rudder-control characteristics

1. In order to determine the ability of the rudder to overcome adverse aileron yaw, measurements were made of the rudder deflection and force used by the pilot in an attempt to hold zero change in sideslip angle as the airplane rolled into a turn. Time histories of this maneuver at 100 miles per hour are given in figures 51 and 52, and at 200 miles per hour in figure 53. In the rolls at 100 miles per hour, sufficient rudder deflection was available to overcome the aileron yaw, but the rudder force required was approximately 250 pounds. This value was considered excessive and exceeds the limit of 180 pounds recommended in reference 2. It is noted that, in the rolls at 200 miles per hour, the pilot used considerably more rudder deflection than was required to hold zero sideslip. With the correct amount of rudder deflection to overcome adverse yaw, however, the force at 200 miles per hour would still be excessive.

2. The rudder control was sufficiently powerful to maintain directional control during take-off and landing. A time history of a landing is given in figure 29.

3. No tests were made to determine the spin-recovery characteristics of the SB2C-1 airplane.

4. As shown in figures 44 to 50, right rudder force was required to hold right rudder deflection

and left rudder force was required to hold left rudder deflection in all flight conditions tested except in the climbing condition at 95 and 120 miles per hour. In these two conditions (figs. 48 and 49), there was a reversal of the rudder-force curves at about 15° sideslip angle. Therefore, Requirement E-3, reference 1, was not satisfied in these flight conditions. No tests were made to check this requirement in the wave-off condition.

5. The hinge-moment coefficients, Ch_δ and Ch_α , of the rudder were estimated from the sideslip data (figs. 44 to 50) and the data from the rudder kicks (figs. 34 and 35). Ch_δ is estimated to be -0.0028 and Ch_α , approximately zero.

II-F. Yawing moment due to sideslip (directional stability)

1. As it is stated in paragraph II-C, maximum angles of sideslip due to ailerons were not obtained, but it appears that the yawing moments due to sideslip (rudder fixed) were sufficient to restrict the aileron yaw to 20° .

2. The yawing moment due to sideslip was always in the correct direction, indicating positive directional stability (rudder fixed); that is, right rudder produced left sideslip and left rudder produced right sideslip. The rudder deflection did not quite vary linearly with sideslip angle. The rudder-fixed directional stability was slightly less at sideslip angles of less than 5° than at larger angles.

3. The yawing moment due to sideslip (rudder free) was found to be such that the airplane would always tend to return to zero sideslip, regardless of the angle of sideslip to which it was forced, in all conditions of flight tested except in the climbing condition at 95 and 120 miles per hour, where rudder-force reversal occurred as discussed in section II-E. If, at 120 miles per hour, the airplane were flown in a sideslip with full left rudder, a force of 100 pounds would be required to return the rudder to its neutral position (fig. 49).

4. The rudder angles and forces required to trim through the speed range in the various conditions of flight are given in figures 12 to 15. There is no requirement specified for the change in rudder trim force with speed, but the pilots felt that in the present instance the changes in rudder trim forces with speed were excessive.

II-G. Cross-wind force characteristics

The variation of cross-wind force with sideslip angle was in the correct direction as shown by the variation of angle of bank with sideslip angle (figs. 44 to 50).

II-H. Pitching moment due to sideslip

The pitching moments due to sideslip are shown by the variation of elevator angle and elevator force with sideslip angle (figs. 44 to 50). Approximately 1° or less change in elevator angle was required at 95 miles per hour when the rudder was moved 5° right or left from its position for straight flight.

II-I. Power of rudder and aileron trim tabs

The power of the rudder trim tab was determined by a method similar to that used to determine the power of the elevator trim tabs (section I-G). Figure 54 gives the rudder forces required to trim through the speed range with two rudder tab settings. The rudder force per degree change in trim tab setting is plotted as a function of speed in figure 55. The change in rudder hinge-moment coefficient per degree change in trim tab angle is given as a function of speed in figure 56. These changes in hinge-moment coefficients are based on free-stream dynamic pressure and on a value of 44.5 feet cubed for the product of the rudder span and chord squared.

The above data show that the rudder trim tab is sufficiently powerful to trim the rudder force to zero throughout the speed range tested (100 to 320 miles per hour).

No quantitative tests were made to determine the power of the aileron trim tab. The aileron trim

forces, however, were small as shown by figure 57, which gives the aileron force and deflection required to trim through the speed range, in one particular flight. These curves would be changed by varying the distribution of fuel load in the wing tanks. The aileron trim tab was reported by the pilot to be adequate for trimming the airplane in all conditions encountered in the tests.

Backlash existed in the rudder and aileron tab control system just as it did in the elevator trim tab system (section I-G). The aileron and rudder trim tabs would retain a given setting indefinitely unless changed manually.

III. Stalling Characteristics

The stalling characteristics of the SB2C-1 airplane were determined in stalls made by gradually decreasing the speed in straight flight. The motions of the airplane and of the controls were recorded by NACA instruments. No tuft studies were made and the effectiveness of the controls with the airplane in a stalled condition was not extensively investigated. The stability characteristics and the maximum lift coefficients during the stall approaches were determined. The gun ports were covered with doped fabric throughout the tests.

Time histories of stall approaches in the various conditions of flight are given in figures 58 to 64. In some cases, the motions of the airplane and the controls after the stall are also presented. The stalling characteristics may be summarized as follows:

(a) In the gliding condition (fig. 58) stall warning was provided by buffeting and by slight pitching motion of the airplane. Rolling instability developed gradually. In the stall shown, the use of the rudder in an attempt to maintain control after the stall resulted in a rolling oscillation. The lift coefficient increased and decreased as the wing alternately stalled and unstalled, so that a steady value of maximum lift coefficient could not be determined. Maximum values ranging from 1.5 to 1.6 were obtained in various stalls.

(b) In the climbing condition (fig. 59), the stall was preceded by mild rolling and pitching motions of the airplane. An initial tendency to

roll right was controlled by use of the ailerons. Later the elevator was moved up 15° and the airplane showed no violent tendency to roll off. Considerable shaking of the controls occurred with the airplane in a stalled condition. The lift coefficient again showed considerable variation. The average value for five stalls was 1.9.

(c) Time histories of stalls in the landing condition are given in figures 60 to 62. The effects of differences in hood and cowl-flap position on the stalling characteristics are shown by figures 60 and 61. With the cowl flaps and hood open (fig. 60), buffeting and shaking of the controls set in at a speed of 10 miles per hour above the stalling speed. Almost full-up elevator angle was applied in order to prevent the airplane from pitching down. No tendency to roll off existed. The maximum lift coefficient reached in this run was 1.91. With the cowl flaps and hood closed (fig. 61), no buffeting was observed until the maximum lift coefficient was reached. The maximum lift coefficient of 2.2 was obtained with only 8° up-elevator angle. Figure 62 is included to show the motion of the airplane after the stall. The rolling motion was very mild.

(d) In the approach condition (fig. 63), full right rudder was required to maintain straight flight near minimum speed. According to the pilot's notes, a slow left roll occurred at the stall. The average maximum lift coefficient in three stalls in the approach condition was 2.4.

(e) In the wave-off condition (fig. 64), full right rudder was insufficient to maintain straight flight near the minimum speed. The maximum lift coefficient appeared to vary in different runs from 2.5 to 3.0. Apparently the ability to reach a stalled condition in straight flight was limited by the lack of rudder power.

Time histories of stalled turns made to the right and left at an acceleration of about $3g$ are given in figures 21 and 22. In both cases the airplane rolled right at the stall. The maximum lift coefficient was about 1.36.

A time history of a three-point landing is given in figure 29. The average lift coefficient at the time of contact with the ground in eight landings made with the SB2C-1 airplane was 1.97. Individual values varied from 1.9 to 2.1. In general, the higher values were obtained when the lift coefficient was rapidly increased before contact.

CONCLUSIONS

1. The short-period longitudinal oscillations of the SB2C-1 airplane were satisfactorily heavily damped. The elevator, when suddenly deflected, however, would not return to the trim position because of the friction in the elevator-control system.
2. The neutral static longitudinal stability point (stick fixed) in the power-off conditions of flight varied from about 34 percent mean aerodynamic chord in the gliding condition to about 31 percent for the landing condition.
3. The application of power had a large destabilizing effect, resulting in an appreciable forward shift of the neutral points.
4. The stability with stick free was less than with stick fixed. The stick-free neutral point was between 3 and 4 percent mean aerodynamic chord forward of the stick-fixed neutral point in most flight conditions.
5. The increase in stability caused by the 11-pound bobweight corresponded to a rearward shift of the stick-free neutral point of 5 percent of the mean aerodynamic chord in all flight conditions.
6. The combined effect of flexibility and friction in the elevator-control system gave the pilot an undesirable impression of instability when he attempted to fly at a constant speed.
7. The stick force per g in maneuvers was satisfactory (3 to 8 pounds per g) in the range of center-of-gravity positions from 28 to 30 percent mean aerodynamic chord. A decrease in the stick-force gradient was observed in dive pull-outs at a Mach number in the neighborhood of 0.6.

8. The longitudinal trim changes due to power and flaps were within the specified limits except when large tab deflections were used for trim as in the landing condition.

9. The elevator tab was sufficiently powerful to trim the airplane as desired in the various flight conditions.

10. The control-free lateral oscillations with amplitudes between 2° and 10° of sideslip damped to one-half amplitude within two cycles, but continuous lateral oscillations of 0.2° to 0.7° amplitude occurred at high speeds. No short-period oscillations of the ailerons existed.

11. The aileron-control effectiveness met neither the Navy nor the NACA minimum requirements.

12. The maximum yaw due to ailerons was not developed but the data indicated that it would be less than the specified value of 20° at 110 percent of the minimum speed.

13. The dihedral effect was positive and quite large in all conditions tested.

14. The rudder provided sufficient directional control during landing and take-off. The rudder power was also adequate to counteract the aileron yaw, but the rudder forces were in excess of the specified 180 pounds pedal force. The changes in rudder trim forces with speed were found to be excessive.

15. The directional stability, rudder fixed, was positive in all conditions and speeds tested. The directional stability rudder free was positive in all conditions and speeds tested with the exception of the climbing condition at 95 and 120 miles per hour. In these two cases, the variation of rudder force with sideslip angle reversed at 15° sideslip, and the direction of the forces reversed at 25° sideslip.

16. The pitching moment due to sideslip was within the required limits, there being less than 1° change of elevator angle required for 5° change of rudder angle.

17. The power of the rudder and aileron trim tabs was adequate.

18. In most flight conditions, there was stall warning of one kind or another. There was either buffeting, shaking of the controls, or a gradual development of pitching or rolling motion.

Langley Memorial Aeronautical Laboratory,
National Advisory Committee for Aeronautics,
Langley Field, Va., March 14, 1944.

REFERENCES

1. Anon.: Specifications for Stability and Control Characteristics of Airplanes. SR-119, Bur. Aero., Oct. 1, 1942.
2. Gilruth, R. R.: Requirements for Satisfactory Flying Qualities of Airplanes. NACA ACR, April 1941.

TABLE I

CHANGES IN TRIM FORCES WITH POWER AND FLAPS

 $V_1 = 120$ MPH, CURTISS SB2C-1 AIRPLANE[Elevator tab setting 0.2° tail heavy, rudder tab setting 10.8° nose right.]

Rpm	Manifold pressure in. Hg at 5000 ft	Flaps	Landing gear	Front hood	Rear hood	Cowl flaps	Bomb and vision doors	Elevator force (lb)	Rudder force (lb)
2400	38	Up	Up	Closed	Closed	Open	Closed	0	8 left
Power off	Power off	Up	Up	Closed	Closed	Closed	Closed	14 pull	62 left
Power off	Power off	Up	Down	Closed	Closed	Closed	Closed	17.5 pull	68 left
Power off	Power off	Down	Down	Closed	Closed	Closed	Closed	15 pull	87 left
Power off	Power off	Down	Down	Open	Closed	Closed	Closed	14 pull	84 left
2400	38	Down	Down	Open	Closed	Open	Closed	3.5 pull	66 left
2400	21	One-half down	Down	Open	Closed	Closed	Closed	10.7 pull	45 left

SUMMARY OF HANDLING CHARACTERISTICS SB2C-1 NACA FLIGHT DETERMINATION

L-571

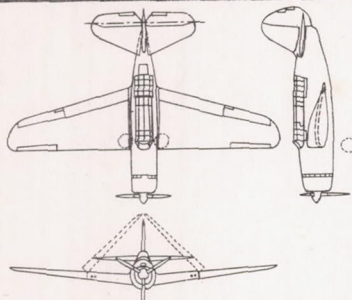
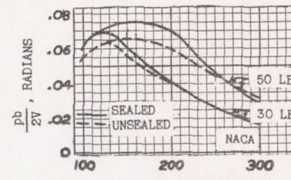
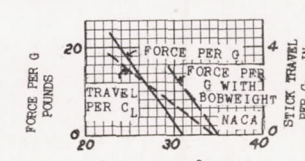
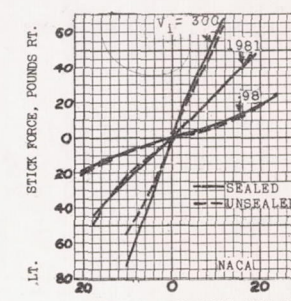
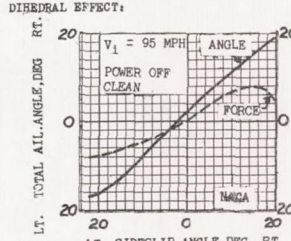
AIRPLANE AS TESTED	LONGITUDINAL	LATERAL																																																						
	<table border="1" style="width: 100%; border-collapse: collapse;"> <thead> <tr> <th rowspan="2">FLIGHT CONDITION</th> <th rowspan="2">LIFT COEFFICIENT</th> <th colspan="2">C.G. POSITION FOR NEUTRAL STABILITY</th> </tr> <tr> <th>STICK FIXED</th> <th>STICK FREE</th> </tr> </thead> <tbody> <tr><td>GLIDING</td><td>1.0</td><td>34.0</td><td>30.2</td></tr> <tr><td>CLIMBING</td><td>0.3</td><td>30.2</td><td>26.9</td></tr> <tr><td>"</td><td>1.0</td><td>26.0</td><td>21.8</td></tr> <tr><td>"</td><td>1.6</td><td>28.2</td><td>--</td></tr> <tr><td>LANDING</td><td>1.0</td><td>30.8</td><td>30.1</td></tr> <tr><td>"</td><td>1.4</td><td>31.5</td><td>--</td></tr> <tr><td>APPROACH</td><td>1.0</td><td>28.1</td><td>25.0</td></tr> <tr><td>WAVE-OFF</td><td>1.0</td><td>27.8</td><td>23.2</td></tr> <tr><td>"</td><td>2.0</td><td>25.4</td><td>--</td></tr> <tr><td>DIVE FLAPS EXTENDED, POWER ON</td><td>0.6</td><td>29.1</td><td>25.1</td></tr> <tr><td>"</td><td>1.0</td><td>26.6</td><td>23.6</td></tr> <tr><td>DIVE FLAPS EXTENDED, POWER OFF</td><td>0.6</td><td>32.7</td><td>28.3</td></tr> </tbody> </table>	FLIGHT CONDITION	LIFT COEFFICIENT	C.G. POSITION FOR NEUTRAL STABILITY		STICK FIXED	STICK FREE	GLIDING	1.0	34.0	30.2	CLIMBING	0.3	30.2	26.9	"	1.0	26.0	21.8	"	1.6	28.2	--	LANDING	1.0	30.8	30.1	"	1.4	31.5	--	APPROACH	1.0	28.1	25.0	WAVE-OFF	1.0	27.8	23.2	"	2.0	25.4	--	DIVE FLAPS EXTENDED, POWER ON	0.6	29.1	25.1	"	1.0	26.6	23.6	DIVE FLAPS EXTENDED, POWER OFF	0.6	32.7	28.3	<p>AILERON POWER:</p> 
FLIGHT CONDITION	LIFT COEFFICIENT			C.G. POSITION FOR NEUTRAL STABILITY																																																				
		STICK FIXED	STICK FREE																																																					
GLIDING	1.0	34.0	30.2																																																					
CLIMBING	0.3	30.2	26.9																																																					
"	1.0	26.0	21.8																																																					
"	1.6	28.2	--																																																					
LANDING	1.0	30.8	30.1																																																					
"	1.4	31.5	--																																																					
APPROACH	1.0	28.1	25.0																																																					
WAVE-OFF	1.0	27.8	23.2																																																					
"	2.0	25.4	--																																																					
DIVE FLAPS EXTENDED, POWER ON	0.6	29.1	25.1																																																					
"	1.0	26.6	23.6																																																					
DIVE FLAPS EXTENDED, POWER OFF	0.6	32.7	28.3																																																					
<p>PERTINENT DETAILS:</p> <p>WEIGHT 12000 TO 12672 LB C. G. RANGE 23.3 TO 32.3 % SPAN 49.72 FT M.A.C. 9.11 FT WING AREA 422 FT² AIRFOIL ROOT 23017; TIP 23009 TYPE FLAP 25° DIVE BRAKES AND 60° SPLIT FLAP</p> <p>CONTROL SURFACE DEFLECTIONS: ELEVATOR (FROM THRUST AXIS) 35.6° UP, 16.6° DOWN AILERON (FROM NEUTRAL) 10.7° UP, 15.0° DOWN RUDDER (FROM THRUST AXIS) 25° LEFT, 29° RIGHT</p> <p>TYPES OF CONTROL SURFACE BALANCE: ELEVATOR INSET HINGE TYPE AILERONS PRIZE TYPE; BALANCE TAB ON RT. AIL. RUDDER INSET HINGE TYPE BALANCE TABS ON ELEVATOR AND RUDDER LOCKED.</p> <p>ENGINE AND RATING: CURTISS-WRIGHT R-2600-8 TAKE OFF 1700 HP AT S. L. MILITARY 1700 HP S. L. TO 3000 FT NORMAL 1500 HP S. L. TO 8700 FT NORMAL 1350 HP 8700 TO 13000 FT</p>	<p>BOBWEIGHT GIVING 11 LB. PULL ON STICK, CAUSED A REARWARD SHIFT OF THE NEUTRAL POINT (STICK FREE) OF 5 % M.A.C. FOR ALL CONDITIONS.</p> <p>MANEUVERING CHARACTERISTICS:</p> 	<p>FORCE VARIATION WITH DEFLECTION:</p> 																																																						
<p>CONTROL FRICTION (AVERAGE VALUES NEAR NEUTRAL):</p> <p>ELEVATOR 5 LB AILERON 4 LB RUDDER 13 LB</p>	<p>CHARACTERISTICS AT HIGH SPEEDS: FORCE PER G IN DIVE PULL-OUTS DECREASED BY ABOUT 8 POUNDS PER G IN GOING FROM MACH NUMBERS OF 0.3 TO 0.426 AT 8000 FEET.</p> <p>TRIM CHANGES DUE TO POWER AND VARIOUS CONFIGURATIONS: AT 120 MPH; ELEVATOR TAB SETTING OF 0.2° TAIL HEAVY AND A RUDDER TAB SETTING OF 10.8° NOSE RIGHT; C.G. AT 23.7 % M.A.C., WHEELS UP, OR 24.2 % M.A.C., WHEELS DOWN.</p> <table border="1" style="width: 100%; border-collapse: collapse;"> <thead> <tr> <th>CONDITION</th> <th>ELEVATOR FORCE</th> <th>RUDDER FORCE</th> </tr> </thead> <tbody> <tr><td>CLIMBING</td><td>0</td><td>8 LEFT</td></tr> <tr><td>GLIDING</td><td>14.0 PULL</td><td>62 "</td></tr> <tr><td>LANDING</td><td>14.0 "</td><td>84 "</td></tr> <tr><td>WAVE-OFF</td><td>3.5 "</td><td>66 "</td></tr> <tr><td>APPROACH</td><td>10.7 "</td><td>45 "</td></tr> </tbody> </table>	CONDITION	ELEVATOR FORCE	RUDDER FORCE	CLIMBING	0	8 LEFT	GLIDING	14.0 PULL	62 "	LANDING	14.0 "	84 "	WAVE-OFF	3.5 "	66 "	APPROACH	10.7 "	45 "	<p>AILERON TRIM CHARACTERISTICS: LARGE AILERON TRIM FORCE VARIATIONS AT HIGH SPEED. AILERON ANGLE AND FORCE MAY BE CHANGED CONSIDERABLY BY GAS LOAD IN WING TANKS AS WELL AS AILERON TAB SETTING.</p>																																				
CONDITION	ELEVATOR FORCE	RUDDER FORCE																																																						
CLIMBING	0	8 LEFT																																																						
GLIDING	14.0 PULL	62 "																																																						
LANDING	14.0 "	84 "																																																						
WAVE-OFF	3.5 "	66 "																																																						
APPROACH	10.7 "	45 "																																																						
<p>REMARKS: CONVENTIONAL LANDING GEAR. SLOTS IN LEADING EDGE OF WING AHEAD OF AILERONS OPEN WHEN LANDING GEAR IS DOWN. MANUFACTURED BY CURTISS-WRIGHT CORP., AIRPLANE DIVISION, COLUMBUS, OHIO. TESTS AT HIGH MACH NUMBERS MADE ON AIRPLANE 0008 AND 00140. ALL OTHER FLYING QUALITIES WERE MADE ON AIRPLANE 00014. REFERENCE: BRIDGEMAN, W.H., WILLIAMS, W.C., AND HOOVER, G.E.; MEASUREMENTS OF FLYING QUALITIES OF A CURTISS SB2C-1 AIRPLANE (NO. 00014). O.S.E. FOR BUR. ARMO., NAVY DEPT., MAR. 16, 1944.</p>	<p>ELEVATOR TRIM TABS ADEQUATE IN ALL CONDITIONS EXCEPT LANDING BELOW 96 MPH. ELEVATOR TRIM TABS 1/3 AS POWERFUL IN LANDING CONDITION AS IN WAVE-OFF. EXCESSIVE PUSH FORCES RESULT IF FULL POWER IS APPLIED WHEN TAB IS FULL TAIL-HEAVY.</p> <p>CONTROL IN LANDING AND TAKE OFF: ADEQUATE TO CENTER OF GRAVITY OF 14 % M.A.C.</p> <p>DYNAMIC: NO SHORT PERIOD OSCILLATION WAS OBTAINED WITH OR WITHOUT BOBWEIGHT.</p>	<p>DIHEDRAL EFFECT: </p> <p>POSITIVE DIHEDRAL EFFECT IN ALL CONDITIONS.</p>																																																						
	<p>REMARKS: TAIL BUZZING REPORTED AT 290 TO 300 KNOTS WITH THE DIVE BRAKES AT 30°. OPEN COWL FLAPS IN CLIMB CAUSED TAIL BUZZING AT APPROXIMATELY 185 KNOTS.</p>	<p>REMARKS: AT LOW SPEEDS AILERON FORCE IN SIDESLIP WAS OF THE SAME MAGNITUDE AS THE FRICTIONAL FORCE.</p>																																																						

SUMMARY OF HANDLING CHARACTERISTICS SB2C-1
NACA FLIGHT DETERMINATION - CONCLUDED

L-571

DIRECTIONAL				STALLING																																																																													
<p>YAWING MOMENT DUE TO SIDESLIP:</p> <p>RT. RUDDER ANGLE, DEG</p> <p>ANGLE $V_1 = 120$ MPH</p> <p>POWER ON CLEAN</p> <p>FORCE</p> <p>NACA</p> <p>LT. SIDESLIP ANGLE, DEG RT.</p> <p>RT. RUDDER FORCE, LB</p> <p>RUDDER REVERSAL DOES NOT OCCUR IN GLIDING OR LANDING CONDITION; AND, DUE TO LARGE RUDDER FORCES LIMITING THE ANGLE OF SIDESLIP, REVERSAL WAS NOT OBTAINED IN CLIMBING CONDITION AT HIGH SPEED.</p>				<table border="1" style="width: 100%; border-collapse: collapse;"> <thead> <tr> <th rowspan="2">FLIGHT CONDITION</th> <th rowspan="2">AVERAGE MAXIMUM LIFT COEFFICIENT</th> <th rowspan="2">WARNING OR REMARKS</th> </tr> </thead> <tbody> <tr> <td>GLIDING</td> <td>1.6</td> <td>BUFFETING AND SLIGHT PITCHING.</td> </tr> <tr> <td>CLIMBING</td> <td>1.9</td> <td>MILD ROLLING AND PITCHING. CONTROLS SHAKING.</td> </tr> <tr> <td>LANDING, COWL AND HOOD OPEN</td> <td>1.9</td> <td>BUFFETING AND SHAKING OF CONTROLS.</td> </tr> <tr> <td>LANDING, COWL AND HOOD CLOSED</td> <td>2.2</td> <td>BUFFETING AT MAXIMUM C_L</td> </tr> <tr> <td>APPROACH</td> <td>2.4</td> <td>PULL RUDDER NECESSARY.</td> </tr> <tr> <td>WAVE-OFF</td> <td>2.5 TO 3.0</td> <td>PULL RUDDER INSUFFICIENT.</td> </tr> <tr> <td>LEFT 180° TURN</td> <td>1.33</td> <td>STALLED AT 3.4g, ROLLED RIGHT.</td> </tr> <tr> <td>RIGHT 180° TURN</td> <td>1.36</td> <td>STALLED AT 3.4g, ROLLED RIGHT.</td> </tr> <tr> <td>LANDING</td> <td>1.97</td> <td>ACTUAL THREE-POINT LANDINGS.</td> </tr> </tbody> </table>	FLIGHT CONDITION	AVERAGE MAXIMUM LIFT COEFFICIENT	WARNING OR REMARKS	GLIDING	1.6	BUFFETING AND SLIGHT PITCHING.	CLIMBING	1.9	MILD ROLLING AND PITCHING. CONTROLS SHAKING.	LANDING, COWL AND HOOD OPEN	1.9	BUFFETING AND SHAKING OF CONTROLS.	LANDING, COWL AND HOOD CLOSED	2.2	BUFFETING AT MAXIMUM C_L	APPROACH	2.4	PULL RUDDER NECESSARY.	WAVE-OFF	2.5 TO 3.0	PULL RUDDER INSUFFICIENT.	LEFT 180° TURN	1.33	STALLED AT 3.4g, ROLLED RIGHT.	RIGHT 180° TURN	1.36	STALLED AT 3.4g, ROLLED RIGHT.	LANDING	1.97	ACTUAL THREE-POINT LANDINGS.																																															
FLIGHT CONDITION	AVERAGE MAXIMUM LIFT COEFFICIENT	WARNING OR REMARKS																																																																															
			GLIDING	1.6	BUFFETING AND SLIGHT PITCHING.																																																																												
CLIMBING	1.9	MILD ROLLING AND PITCHING. CONTROLS SHAKING.																																																																															
LANDING, COWL AND HOOD OPEN	1.9	BUFFETING AND SHAKING OF CONTROLS.																																																																															
LANDING, COWL AND HOOD CLOSED	2.2	BUFFETING AT MAXIMUM C_L																																																																															
APPROACH	2.4	PULL RUDDER NECESSARY.																																																																															
WAVE-OFF	2.5 TO 3.0	PULL RUDDER INSUFFICIENT.																																																																															
LEFT 180° TURN	1.33	STALLED AT 3.4g, ROLLED RIGHT.																																																																															
RIGHT 180° TURN	1.36	STALLED AT 3.4g, ROLLED RIGHT.																																																																															
LANDING	1.97	ACTUAL THREE-POINT LANDINGS.																																																																															
<p>RUDDER TRIM CHARACTERISTICS:</p> <table border="1" style="width: 100%; border-collapse: collapse;"> <thead> <tr> <th rowspan="2">RUDDER TAB SETTING</th> <th rowspan="2">POWER</th> <th colspan="2">FORCE AT</th> </tr> <tr> <th>100 MPH</th> <th>300 MPH</th> </tr> </thead> <tbody> <tr> <td>1.7° RIGHT</td> <td>ON</td> <td>69 RIGHT</td> <td>128 LEFT</td> </tr> <tr> <td>1.7° RIGHT</td> <td>OFF</td> <td>44 LEFT</td> <td>186 "</td> </tr> </tbody> </table>				RUDDER TAB SETTING	POWER	FORCE AT		100 MPH	300 MPH	1.7° RIGHT	ON	69 RIGHT	128 LEFT	1.7° RIGHT	OFF	44 LEFT	186 "																																																																
RUDDER TAB SETTING	POWER	FORCE AT																																																																															
		100 MPH	300 MPH																																																																														
1.7° RIGHT	ON	69 RIGHT	128 LEFT																																																																														
1.7° RIGHT	OFF	44 LEFT	186 "																																																																														
<p>PITCHING MOMENT DUE TO SIDESLIP:</p> <p>LESS THAN 1° OF ELEVATOR REQUIRED FOR SIDESLIP REQUIRING 5° OF RUDDER EXCEPT AT LOW SPEEDS IN THE CLIMBING CONDITION, RIGHT SIDESLIP.</p>																																																																																	
<p>DYNAMIC:</p> <p>OSCILLATIONS DAMPED TO 1/2 AMPLITUDE IN APPROXIMATELY ONE CYCLE. AT LOW SPEEDS, RUDDER DID NOT RETURN TO TRIM POSITION.</p>																																																																																	
<p>REMARKS:</p> <p>AT LOW SPEEDS THE ANGLE OF BANK OBTAINABLE WITH PULL RUDDER IS APPROXIMATELY 5°.</p>				<p>STRAIGHT FLIGHT:</p> <p>IN THE GLIDING CONDITION, BUFFETING AND SLIGHT PITCHING SERVE AS WARNINGS, AND ROLLING INSTABILITY DEVELOPS GRADUALLY. WITH POWER ON, LIGHT ALERON SNATCHING STARTS BEFORE THE STALL, AND MILD LATERAL INSTABILITY OCCURS AT THE STALL. IN LANDING CONDITION, BUFFETING OF THE AIRPLANE AND SHAKING OF THE CONTROLS GIVE AMPLE WARNING, AND AT THE STALL ONLY PITCHING INSTABILITY DEVELOPS.</p> <p>TURNING FLIGHT:</p> <p>THERE IS NO WARNING, BUT AS THE STALL IS REACHED, MILD LATERAL INSTABILITY DEVELOPS WHICH IS EASILY CONTROLLABLE.</p>																																																																													
				<table border="1" style="width: 100%; border-collapse: collapse;"> <thead> <tr> <th>FLIGHT CONDITION</th> <th>BOMB AND VISION DOORS</th> <th>FLAPS</th> <th>LANDING GEAR</th> <th>FRONT HOOD</th> <th>REAR HOOD</th> <th>COWL FLAPS</th> <th>RPM</th> <th>MANIFOLD PRESSURE IN. HG AT 5000 FT.</th> </tr> </thead> <tbody> <tr> <td>GLIDING</td> <td>CLOSED</td> <td>UP</td> <td>UP</td> <td>CLOSED</td> <td>CLOSED</td> <td>CLOSED</td> <td>POWER OFF</td> <td>POWER OFF</td> </tr> <tr> <td>CLIMBING</td> <td>"</td> <td>"</td> <td>"</td> <td>"</td> <td>"</td> <td>"</td> <td>2400</td> <td>38</td> </tr> <tr> <td>LANDING</td> <td>"</td> <td>DOWN</td> <td>DOWN</td> <td>OPEN</td> <td>"</td> <td>CLOSED</td> <td>POWER OFF</td> <td>POWER OFF</td> </tr> <tr> <td>APPROACH</td> <td>"</td> <td>1/2 DOWN</td> <td>"</td> <td>"</td> <td>"</td> <td>OPEN</td> <td>2400</td> <td>21</td> </tr> <tr> <td>WAVE-OFF</td> <td>"</td> <td>DOWN</td> <td>"</td> <td>"</td> <td>"</td> <td>"</td> <td>2400</td> <td>38</td> </tr> <tr> <td>DIVE FLAPS OPEN</td> <td>OPEN</td> <td>DIVE FLAPS OPEN</td> <td>UP</td> <td>"</td> <td>"</td> <td>"</td> <td>POWER OFF</td> <td>POWER OFF</td> </tr> <tr> <td>DIVE FLAPS OPEN</td> <td>"</td> <td>DIVE FLAPS OPEN</td> <td>"</td> <td>"</td> <td>"</td> <td>"</td> <td>2400</td> <td>25</td> </tr> </tbody> </table>						FLIGHT CONDITION	BOMB AND VISION DOORS	FLAPS	LANDING GEAR	FRONT HOOD	REAR HOOD	COWL FLAPS	RPM	MANIFOLD PRESSURE IN. HG AT 5000 FT.	GLIDING	CLOSED	UP	UP	CLOSED	CLOSED	CLOSED	POWER OFF	POWER OFF	CLIMBING	"	"	"	"	"	"	2400	38	LANDING	"	DOWN	DOWN	OPEN	"	CLOSED	POWER OFF	POWER OFF	APPROACH	"	1/2 DOWN	"	"	"	OPEN	2400	21	WAVE-OFF	"	DOWN	"	"	"	"	2400	38	DIVE FLAPS OPEN	OPEN	DIVE FLAPS OPEN	UP	"	"	"	POWER OFF	POWER OFF	DIVE FLAPS OPEN	"	DIVE FLAPS OPEN	"	"	"	"	2400	25
FLIGHT CONDITION	BOMB AND VISION DOORS	FLAPS	LANDING GEAR	FRONT HOOD	REAR HOOD	COWL FLAPS	RPM	MANIFOLD PRESSURE IN. HG AT 5000 FT.																																																																									
GLIDING	CLOSED	UP	UP	CLOSED	CLOSED	CLOSED	POWER OFF	POWER OFF																																																																									
CLIMBING	"	"	"	"	"	"	2400	38																																																																									
LANDING	"	DOWN	DOWN	OPEN	"	CLOSED	POWER OFF	POWER OFF																																																																									
APPROACH	"	1/2 DOWN	"	"	"	OPEN	2400	21																																																																									
WAVE-OFF	"	DOWN	"	"	"	"	2400	38																																																																									
DIVE FLAPS OPEN	OPEN	DIVE FLAPS OPEN	UP	"	"	"	POWER OFF	POWER OFF																																																																									
DIVE FLAPS OPEN	"	DIVE FLAPS OPEN	"	"	"	"	2400	25																																																																									

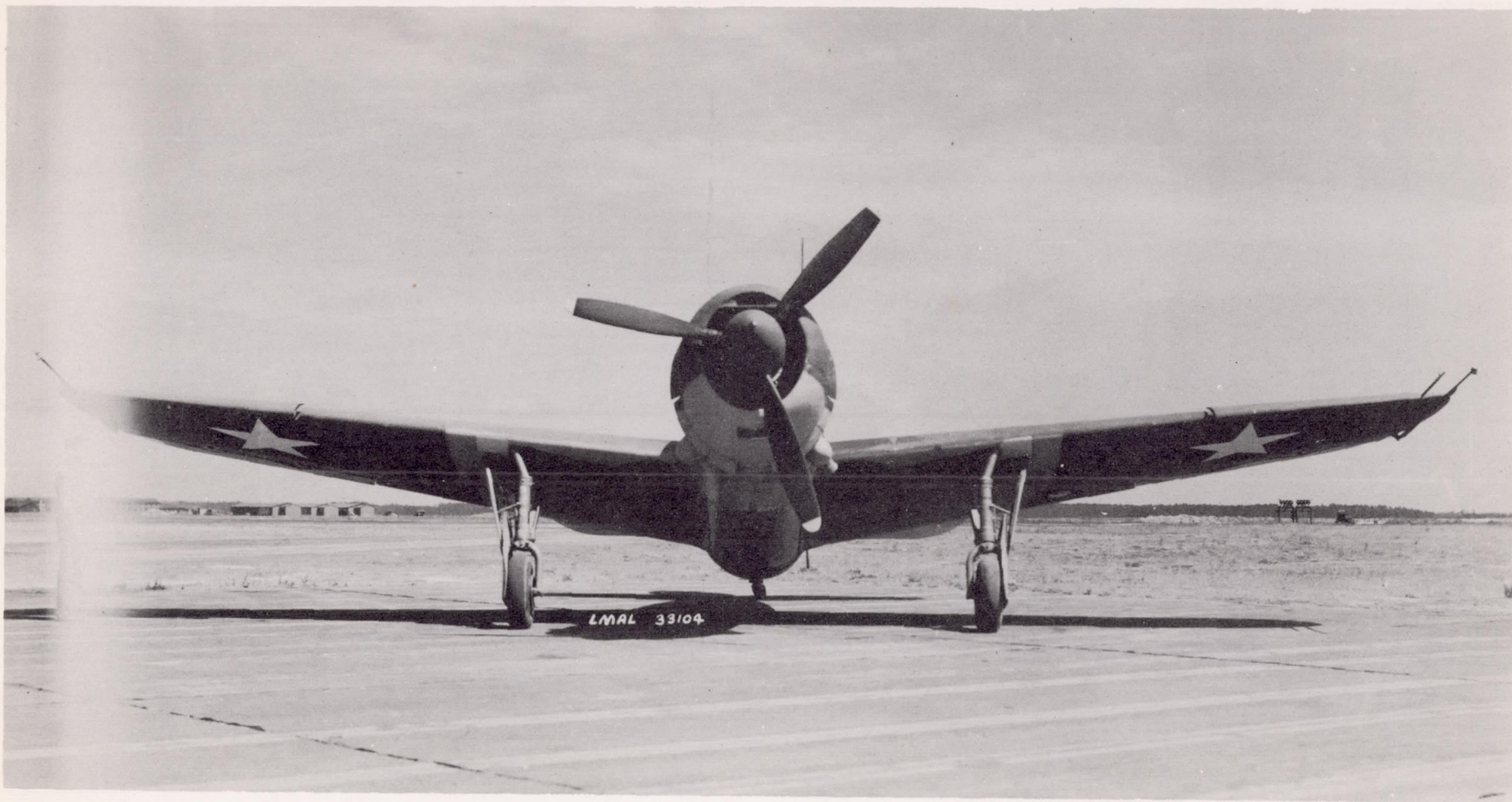

Figure 1.- Front view of Curtiss SB2C-1 airplane (Bureau of Aeronautics No. 00014).

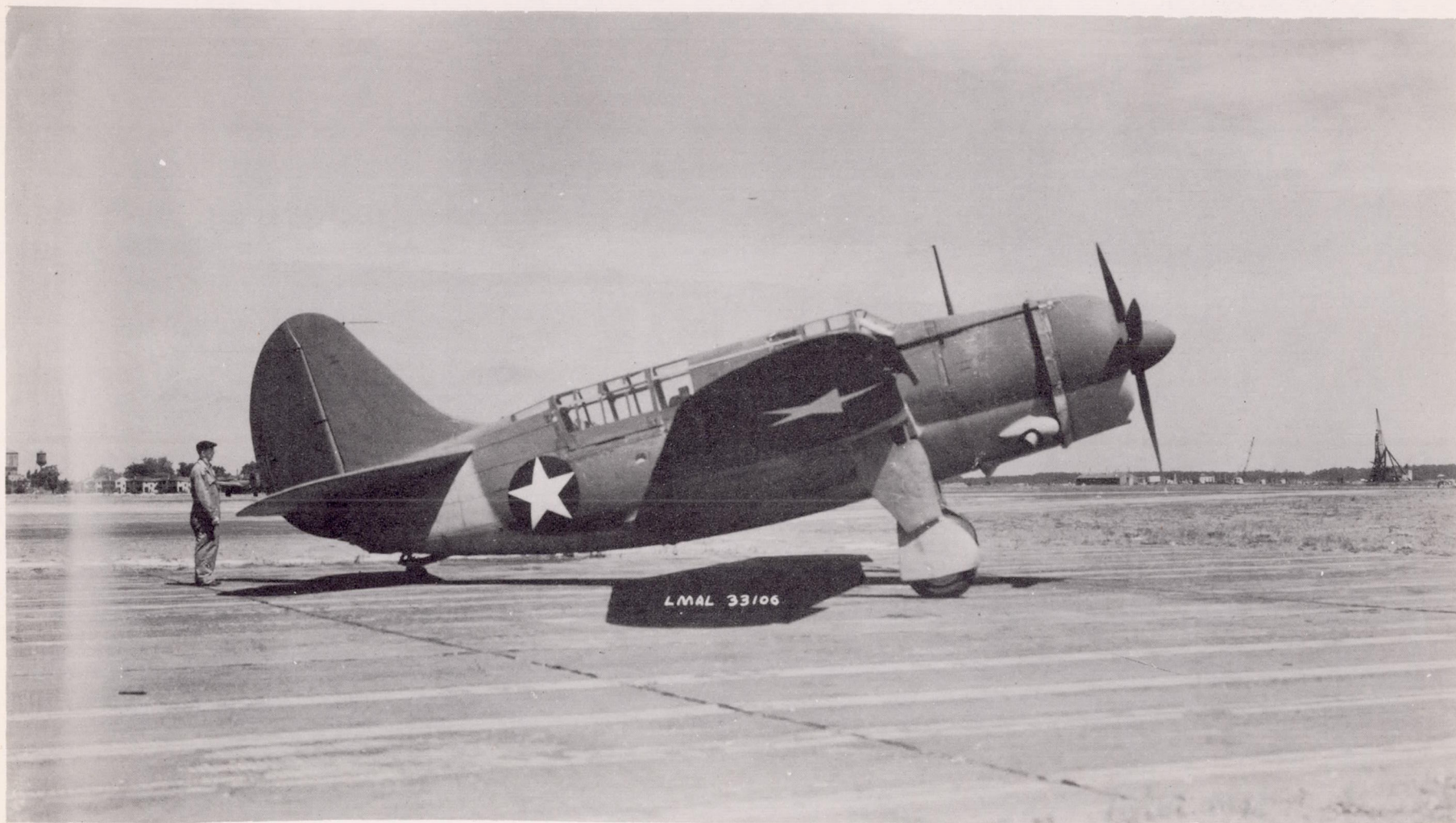

Figure 2.- Side view of Curtiss SB2C-1 airplane (Bureau of Aeronautics No. 00014).

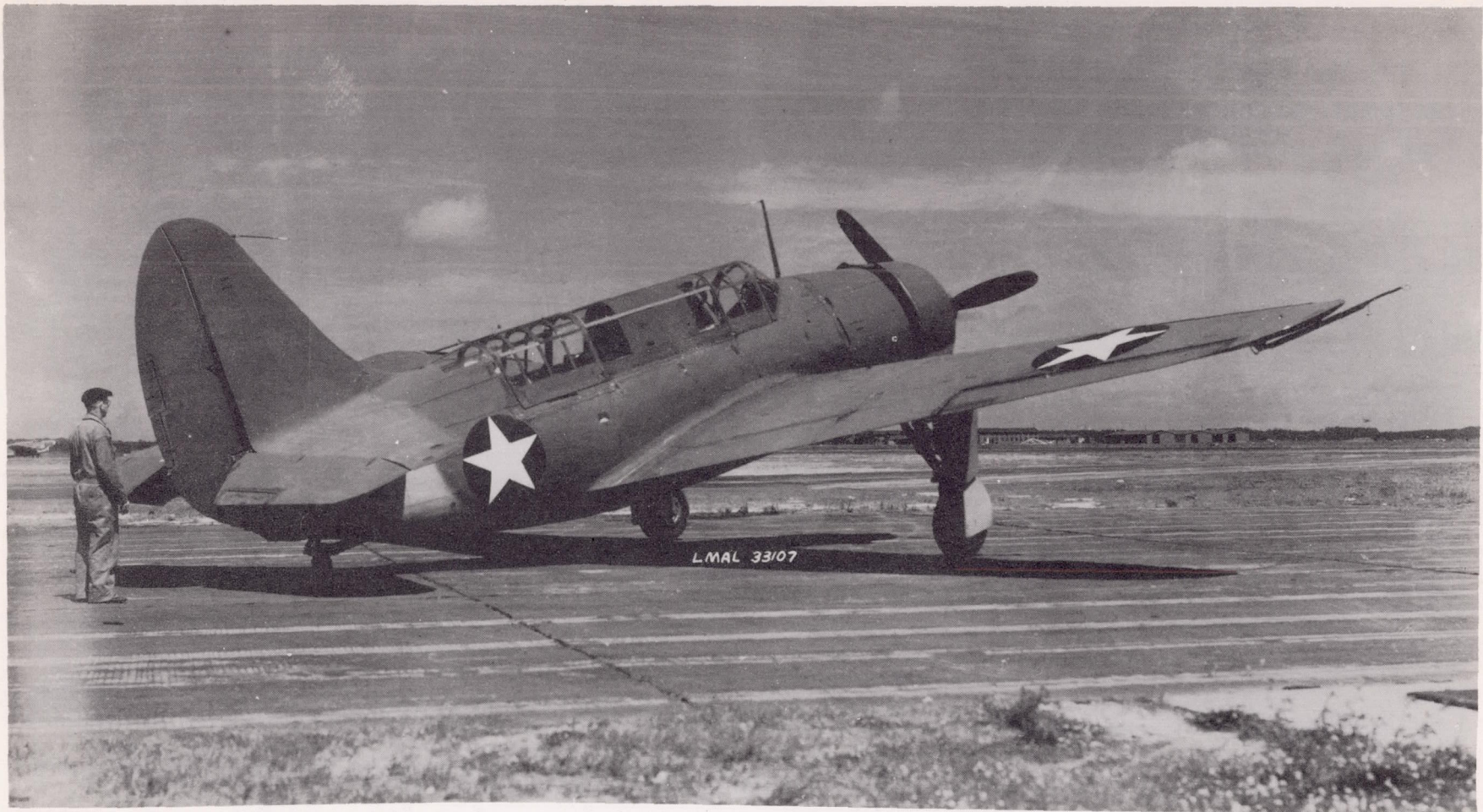

Figure 3.- Three-quarter rear view of Curtiss SB2C-1 airplane (Bureau of Aeronautics No. 00014).

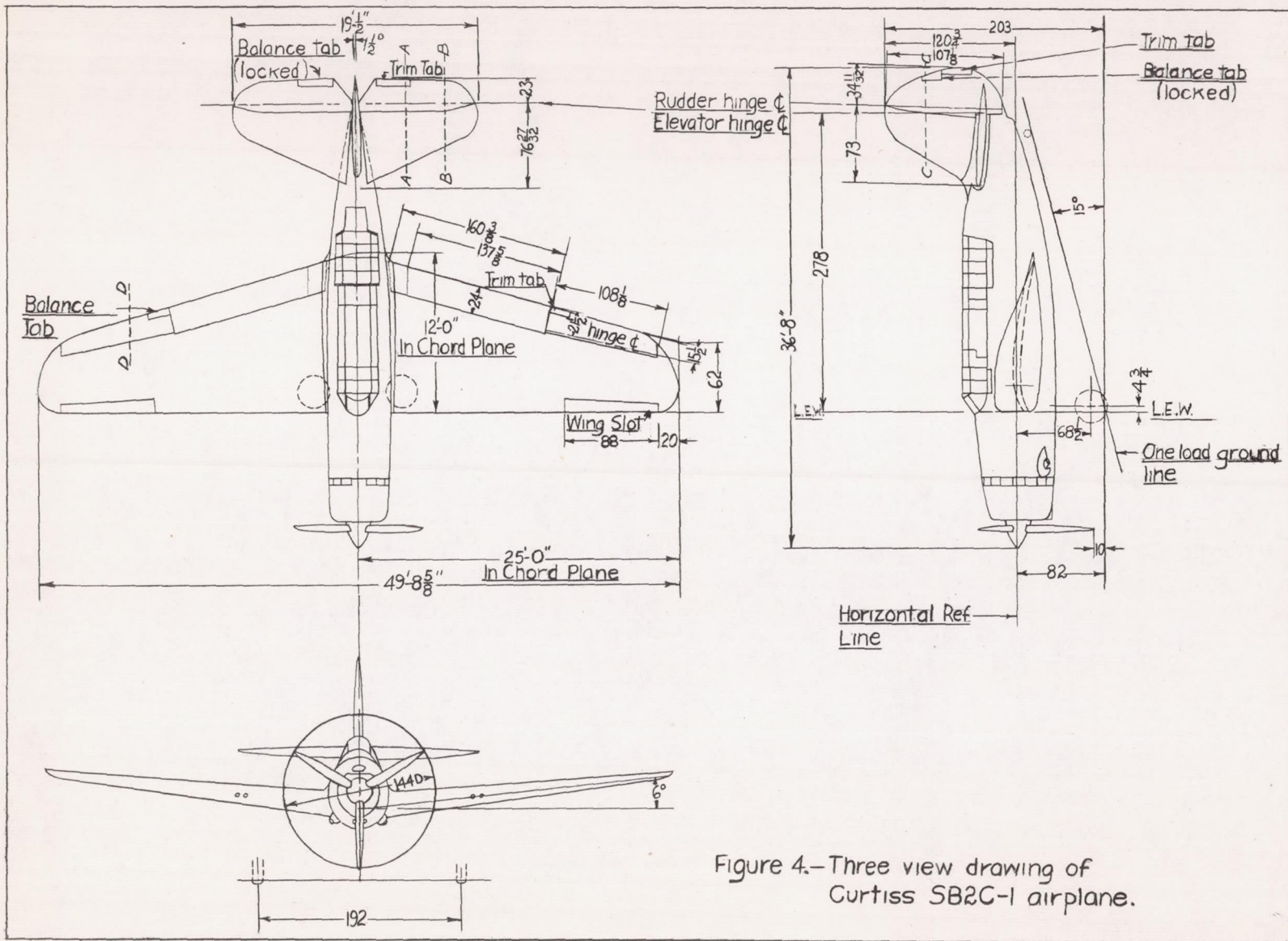

Figure 4.—Three view drawing of Curtiss SB2C-1 airplane.

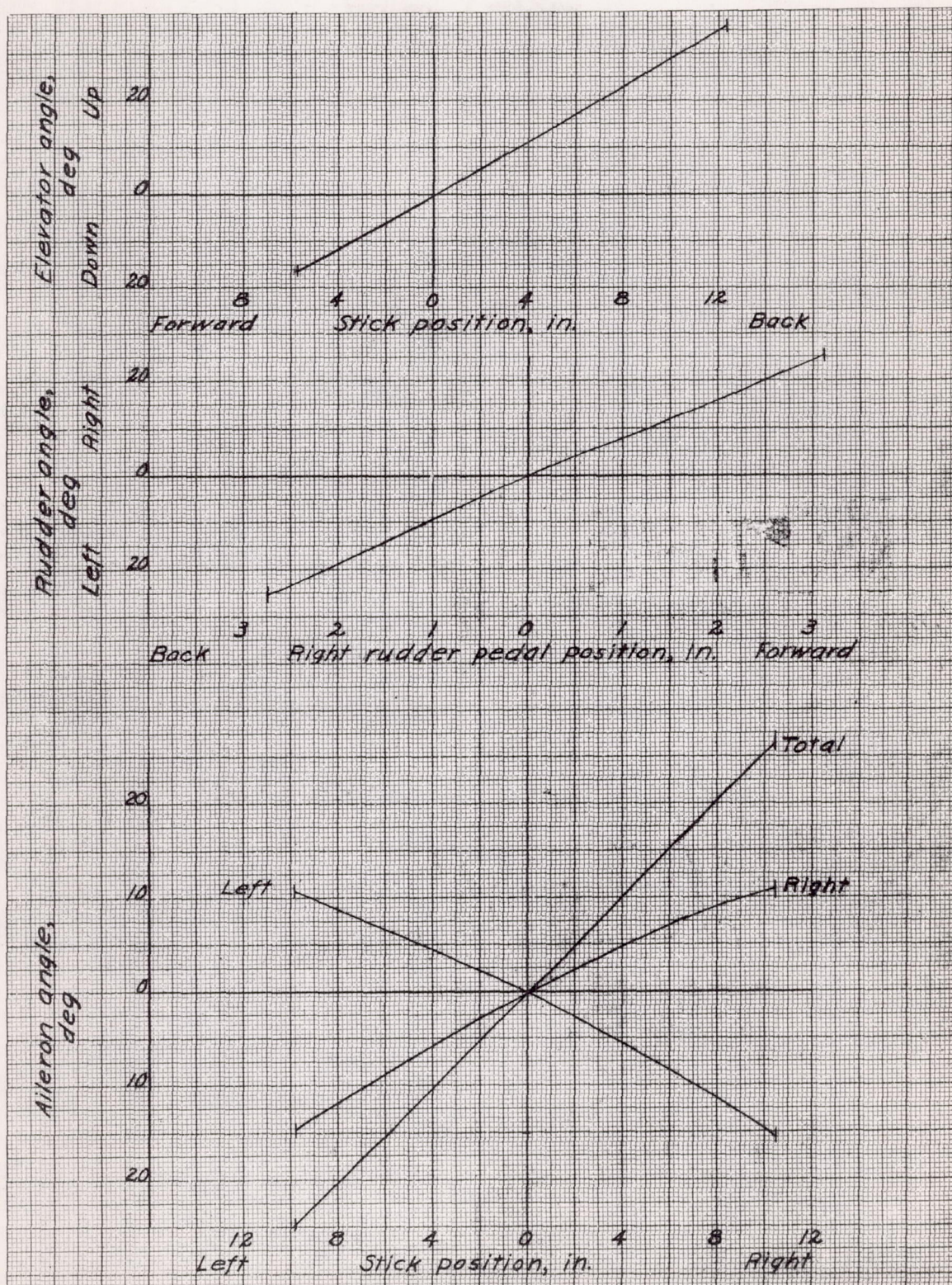
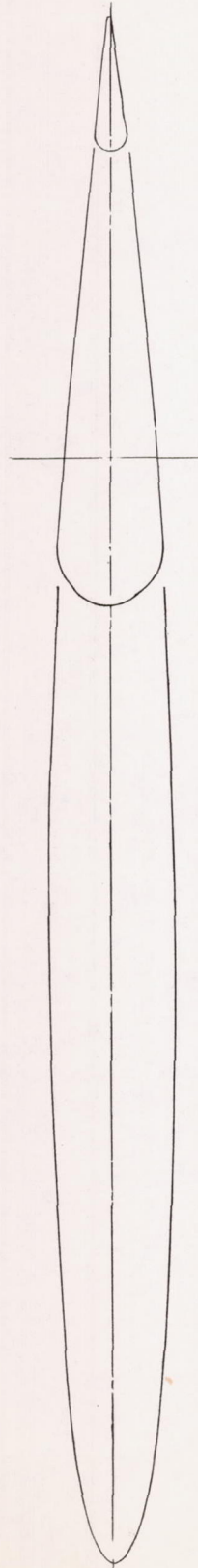
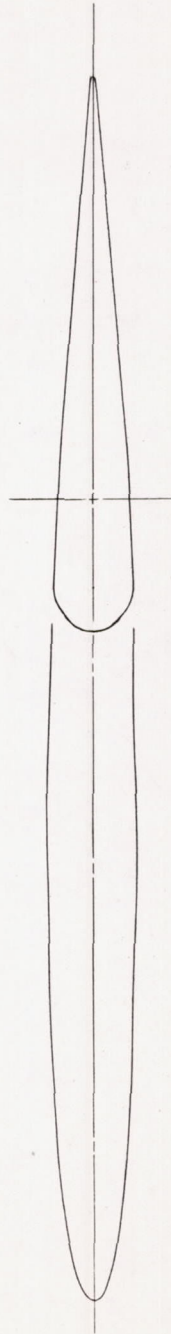

Figure 5.- Relation between control surface deflections and stick and rudder pedal positions. (Elevator and rudder angles with respect to thrust axis; ailerons with respect to their neutral position.) Curtiss SB2C-1 airplane.



Section A-A (Fig. 4)



Section B-B (Fig. 4)

Figure 6.- Sections of horizontal tail Curtiss SB2C-1

L-571

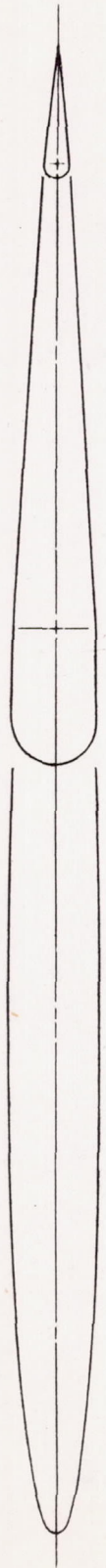

Section C-C (fig. 4)

*Figure 7. - Section of vertical tail,
SB2C-1 airplane*

L-571

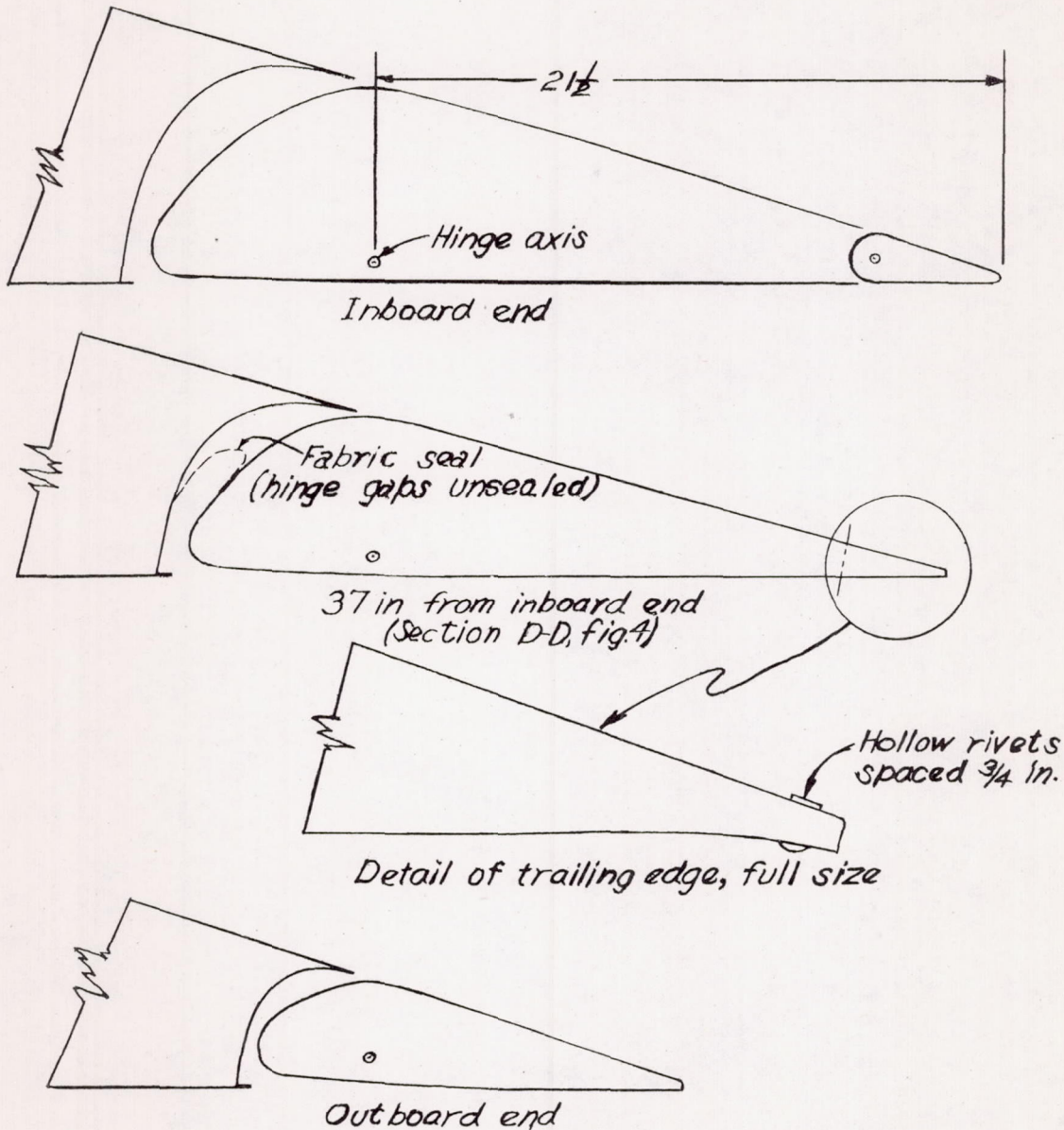

Aileron metal covered except lower surface from spar to trailing edge, which is fabric covered

Figure 8.- Typical aileron sections, Curtiss SB2C-1 airplane.

1-571

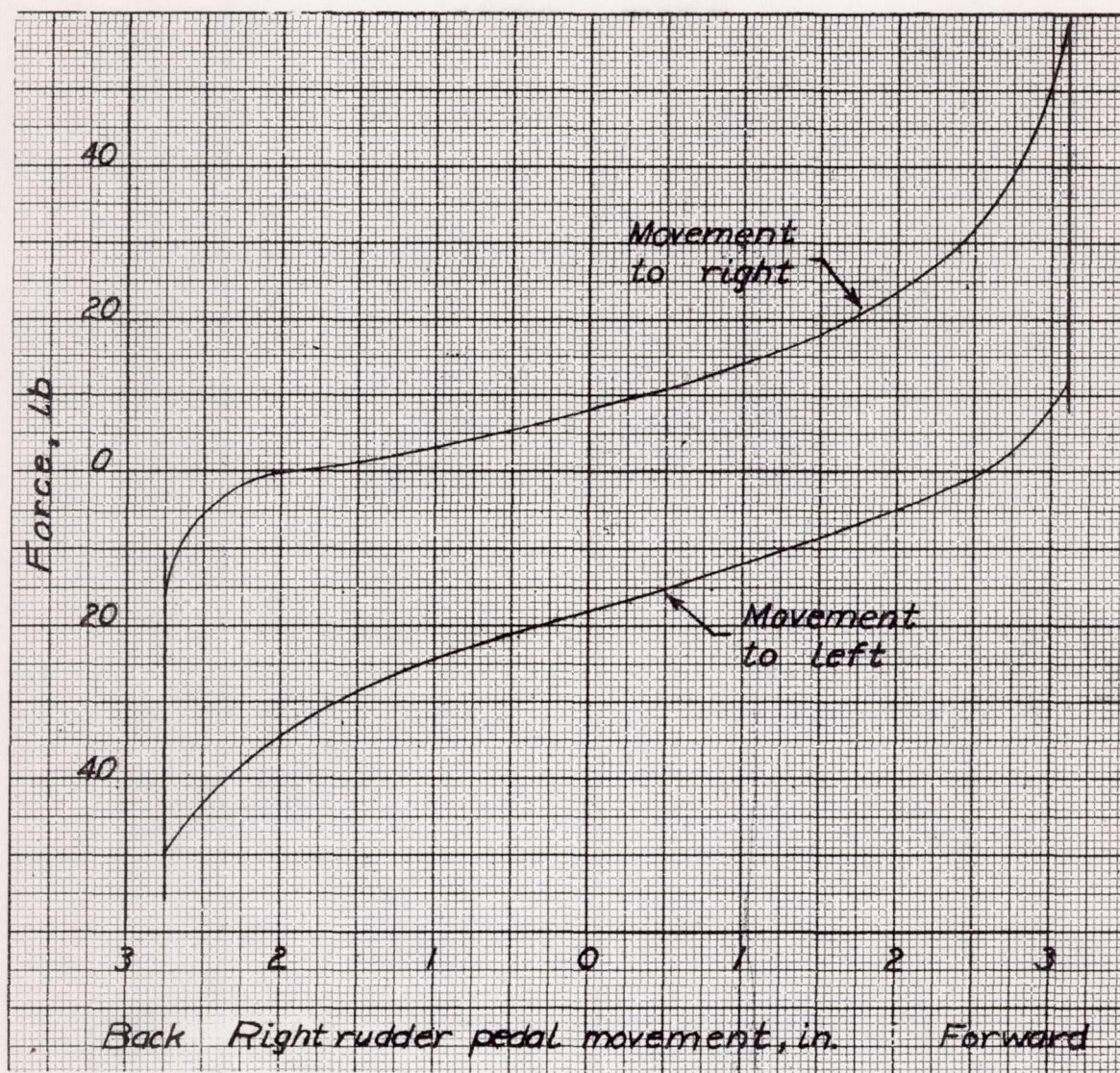

Figure 9.- Rudder pedal force required to move the rudder slowly as measured on the ground. Curtiss SB2C-1.

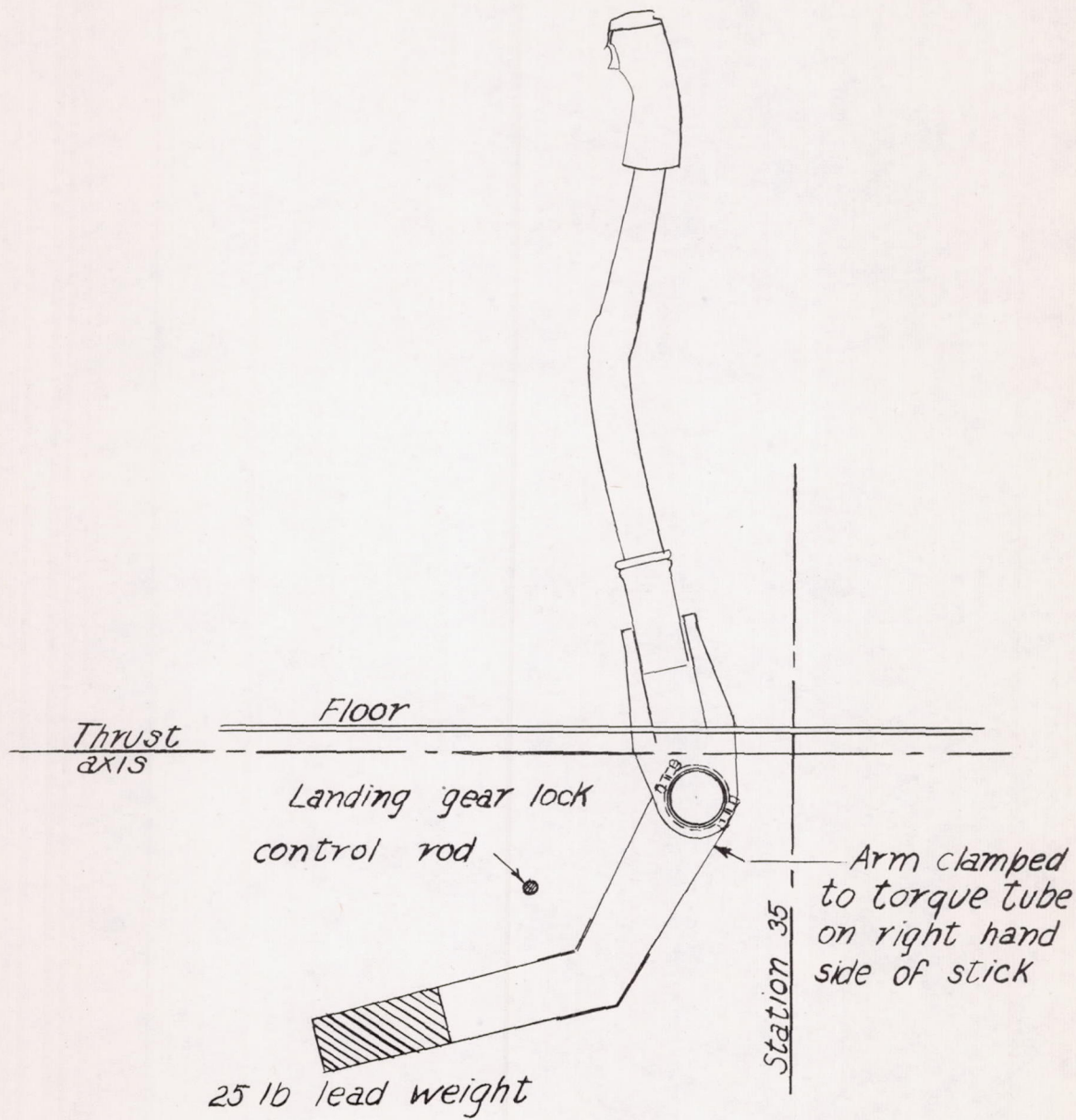

Figure 10.- Sketch of bobweight installation in Curtiss SB2C-1 airplane.

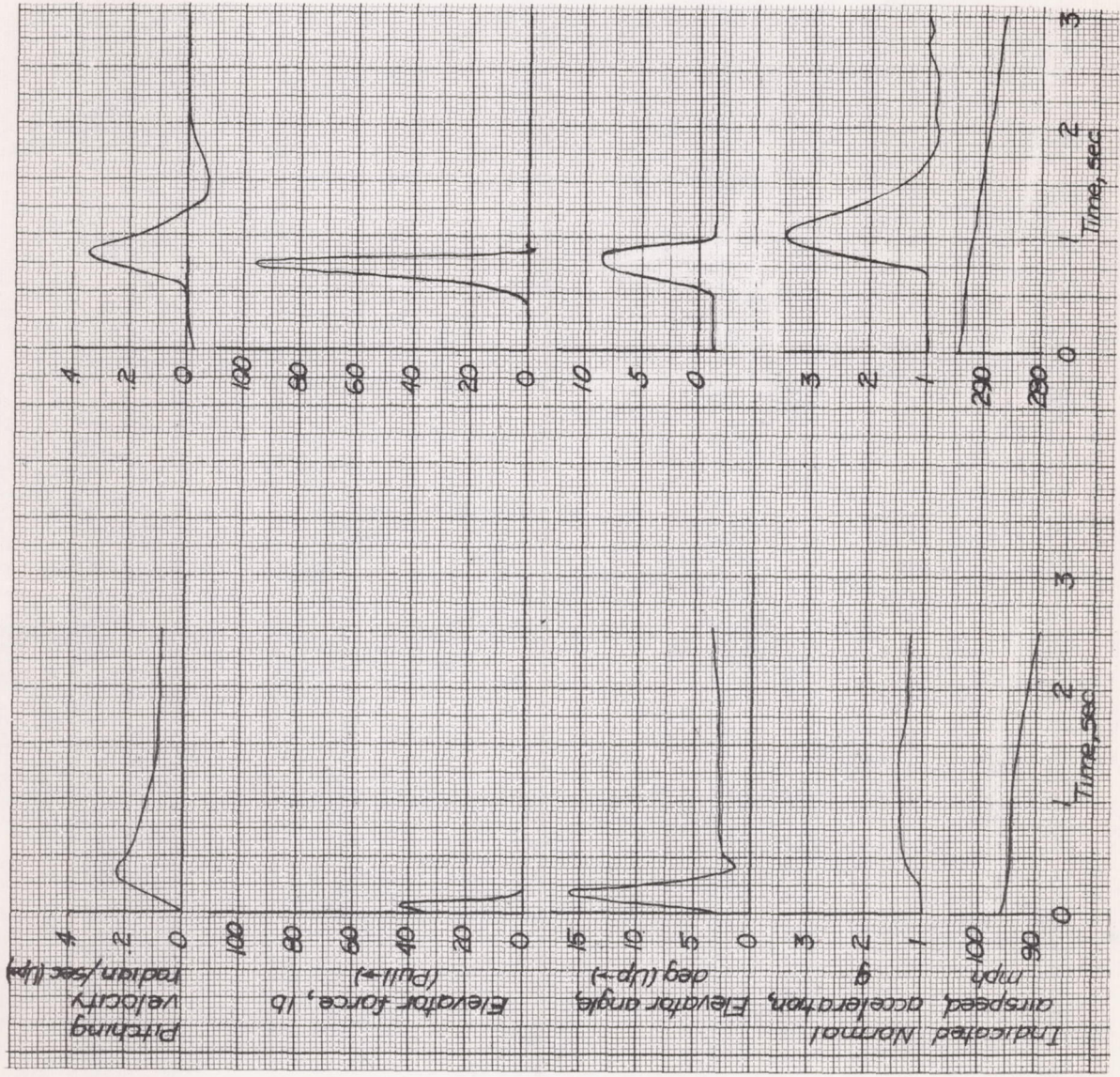

Figure 11.- Time histories of typical attempted longitudinal oscillations. SE2C-1 airplane (flaps up, landing gear up, rated power).

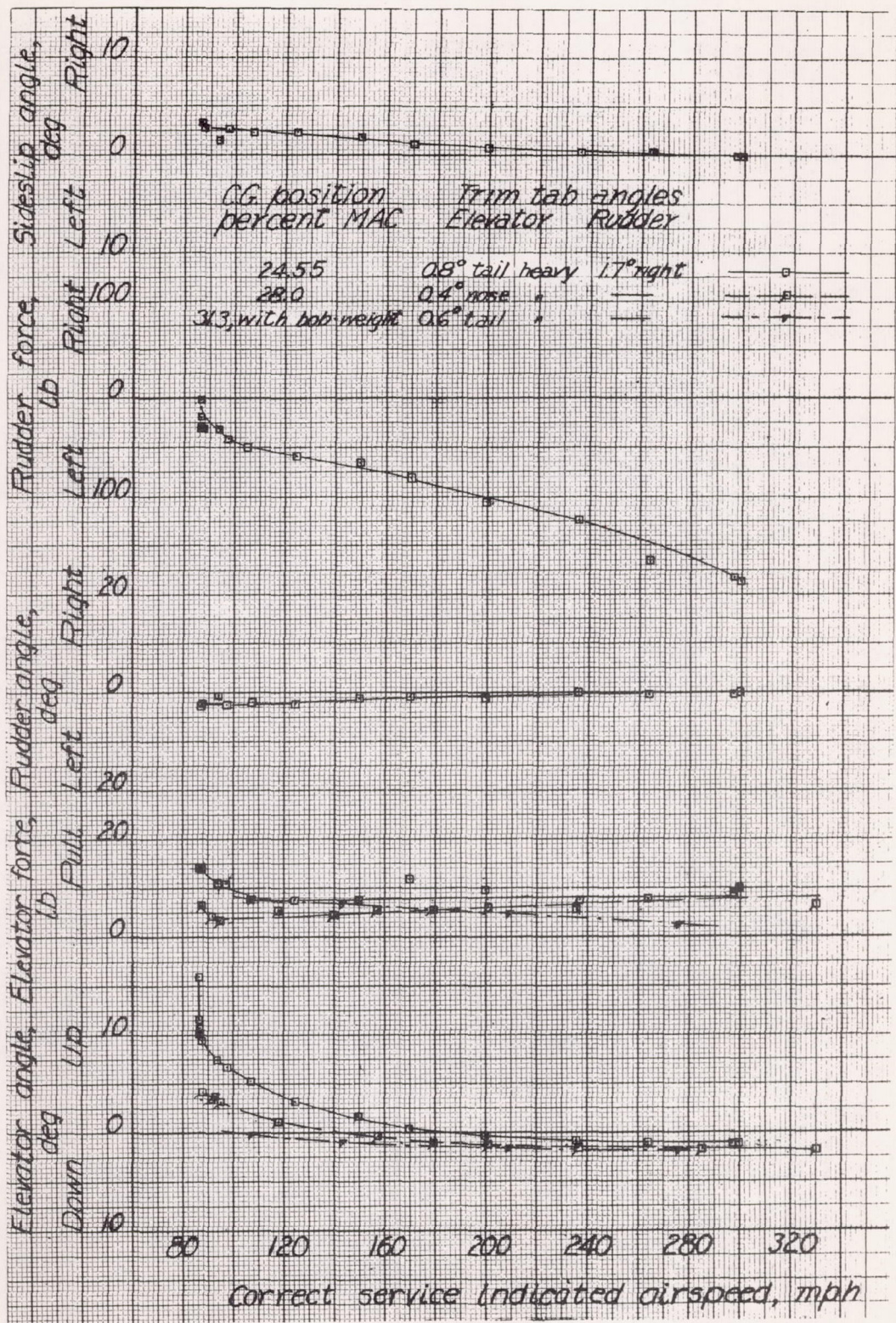

Figure 12.- Static longitudinal stability characteristics in the gliding condition (flaps up, landing gear up, power off) Curtiss SB2C-1 airplane.

L-571

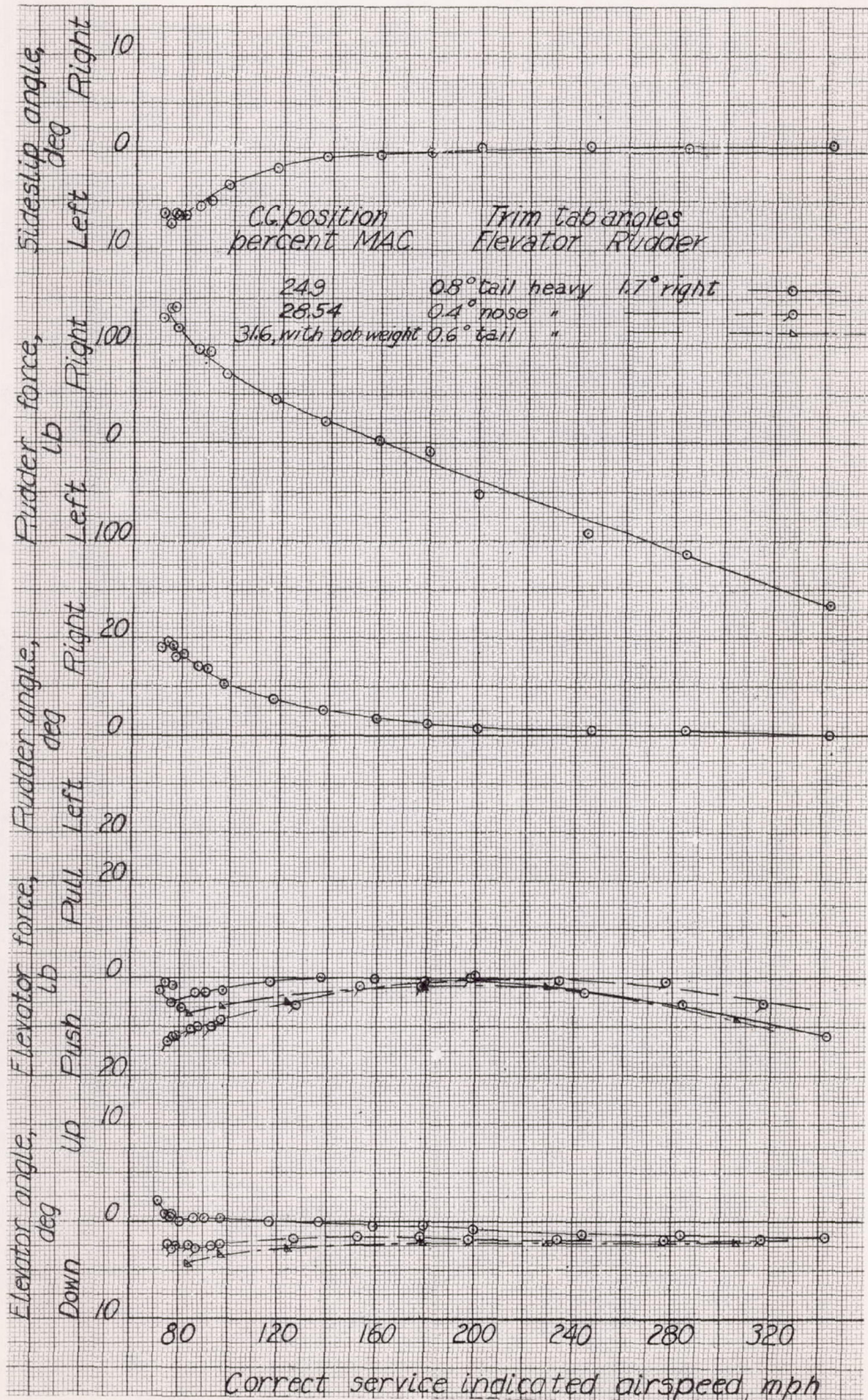
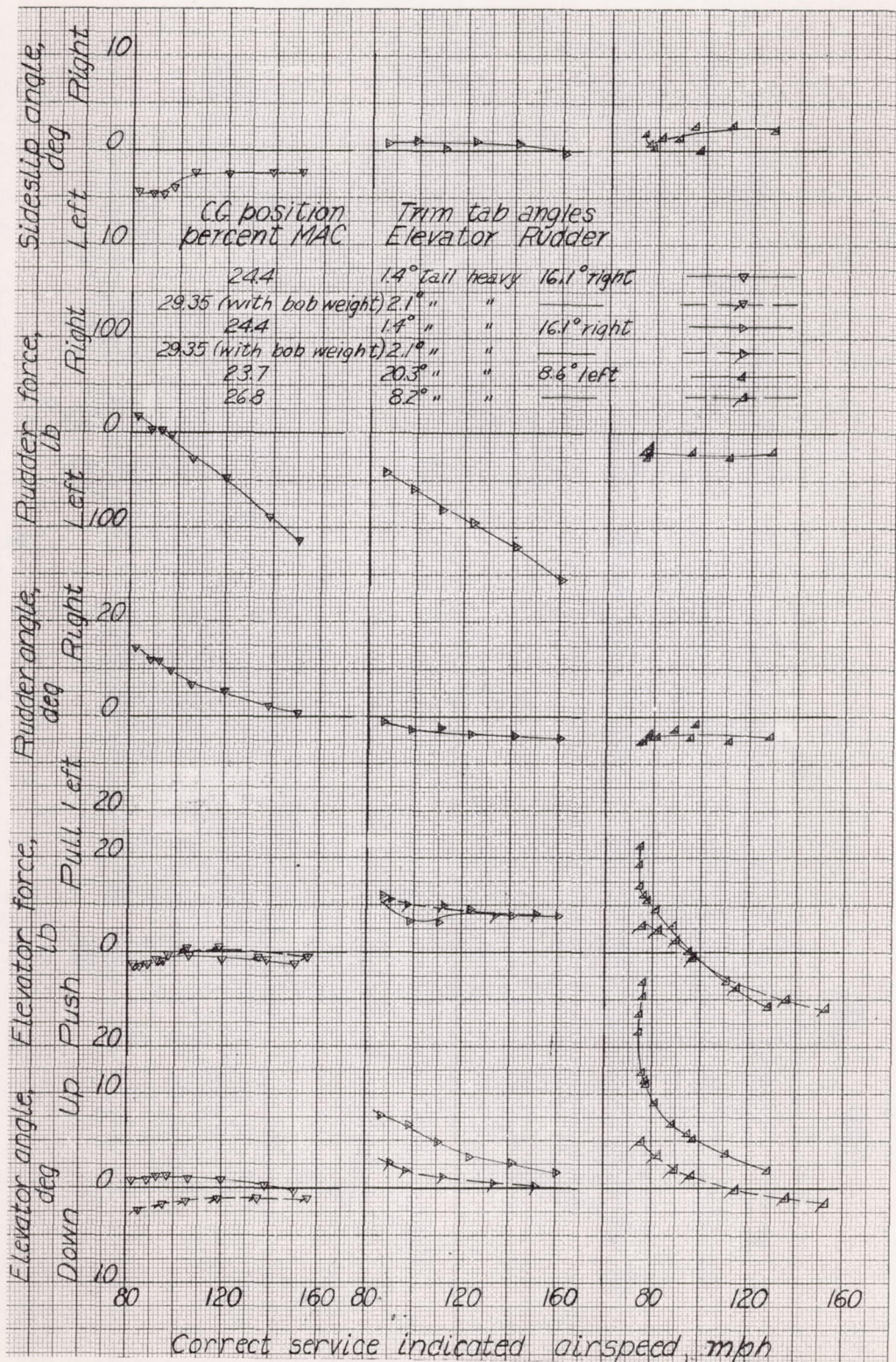

Figure 13.- Static longitudinal stability characteristics in the climbing condition (flaps up, landing gear up, rated power) Curtiss SB2C-1 airplane.

571



(a) Dive flaps extended, power on. (b) Dive flaps extended, power off. (c) Landing condition (flaps down, gear down, power off).

Figure 14.- Static longitudinal stability characteristics, Curtiss SB2C-1 airplane.

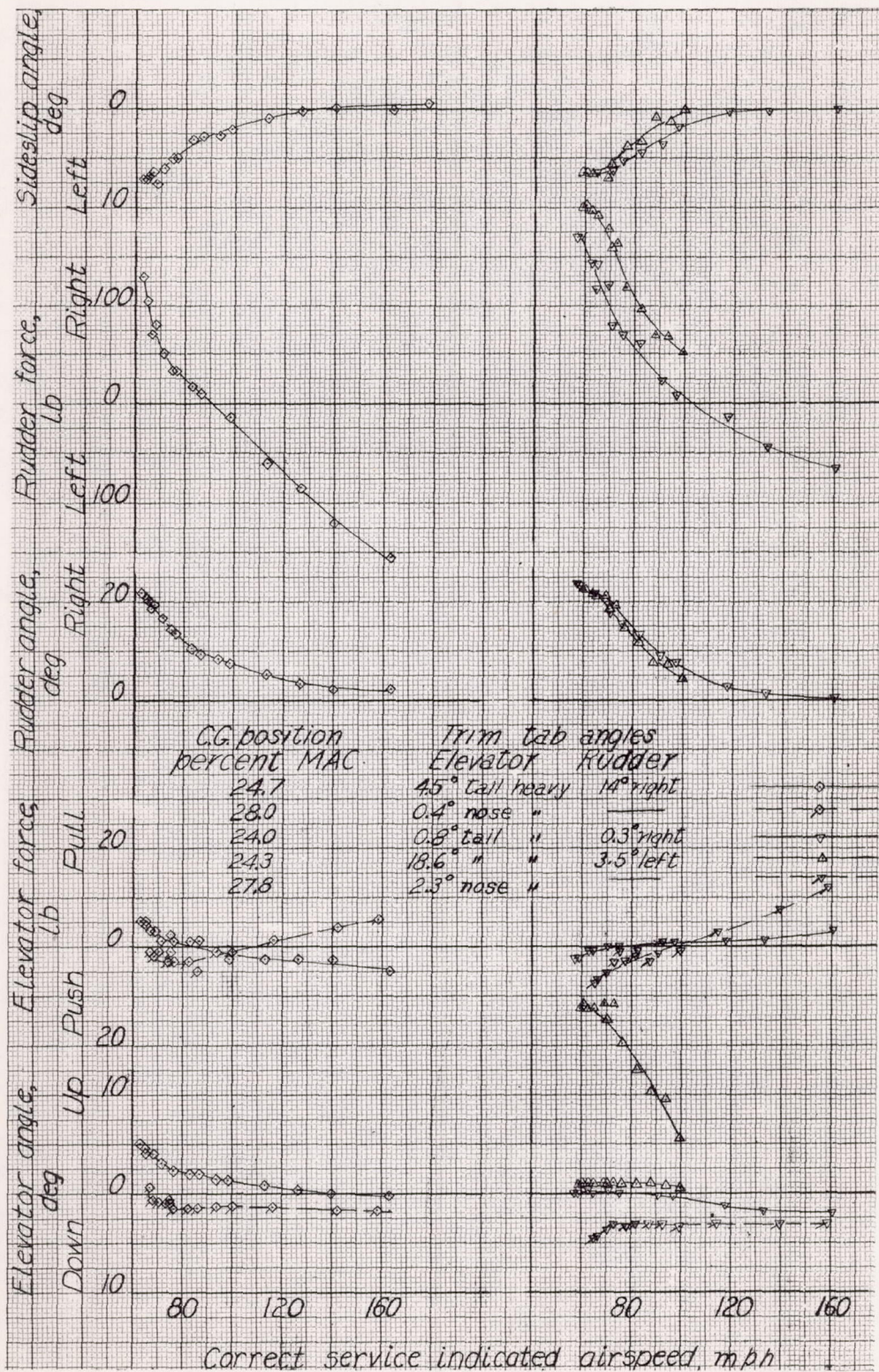

(a) Approach condition (flaps one-half down, landing gear down, partial power). (b) Wave-off condition (flaps down, landing gear down, rated power).

Figure 15.- Static longitudinal stability characteristics, Curtiss SB2C-1 airplane.

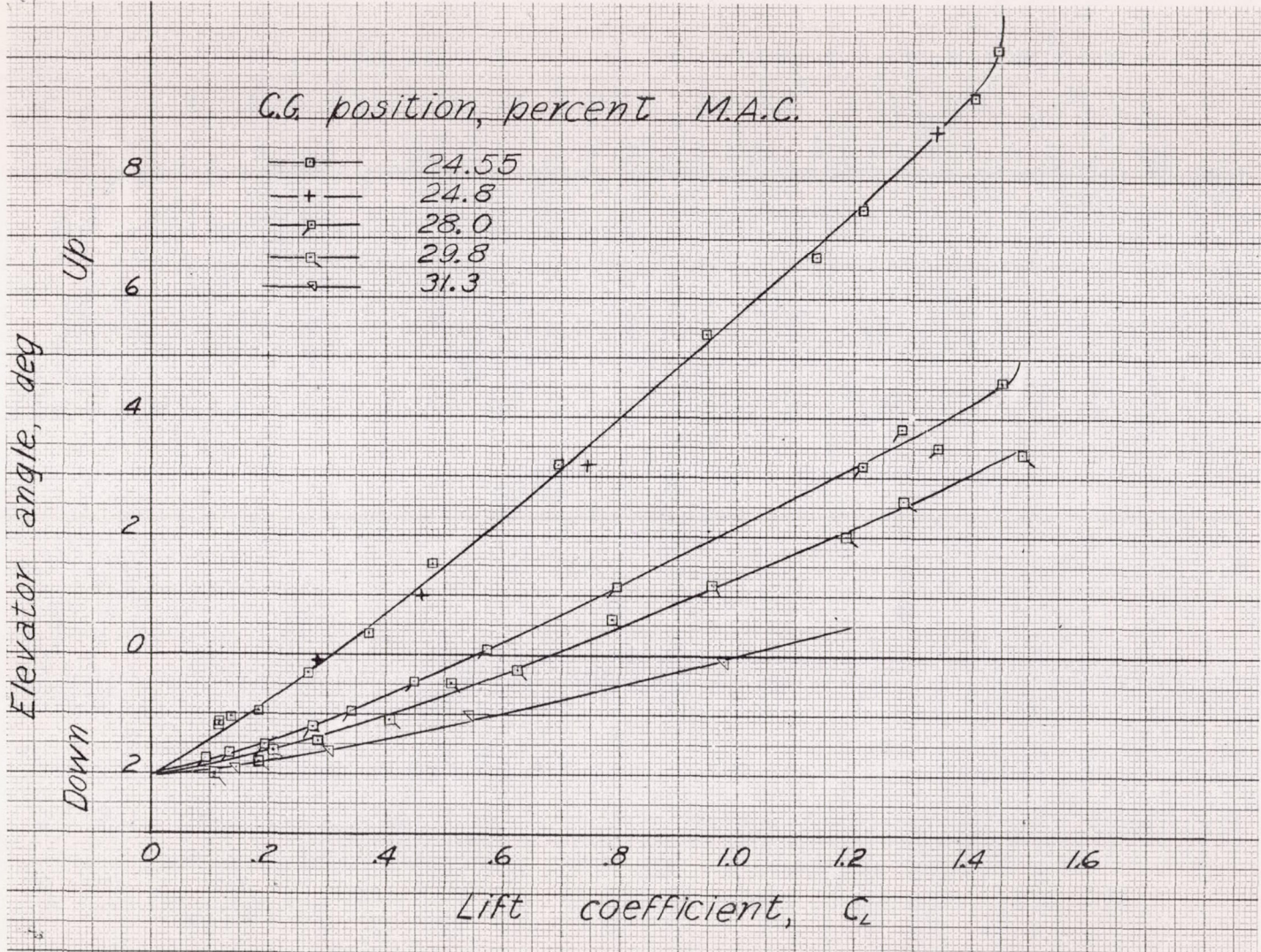

Figure 16.- Variation of elevator angle measured from thrust axis with lift coefficient in the gliding condition (flaps up, landing gear up, power off) Curtiss SB2C-1 airplane

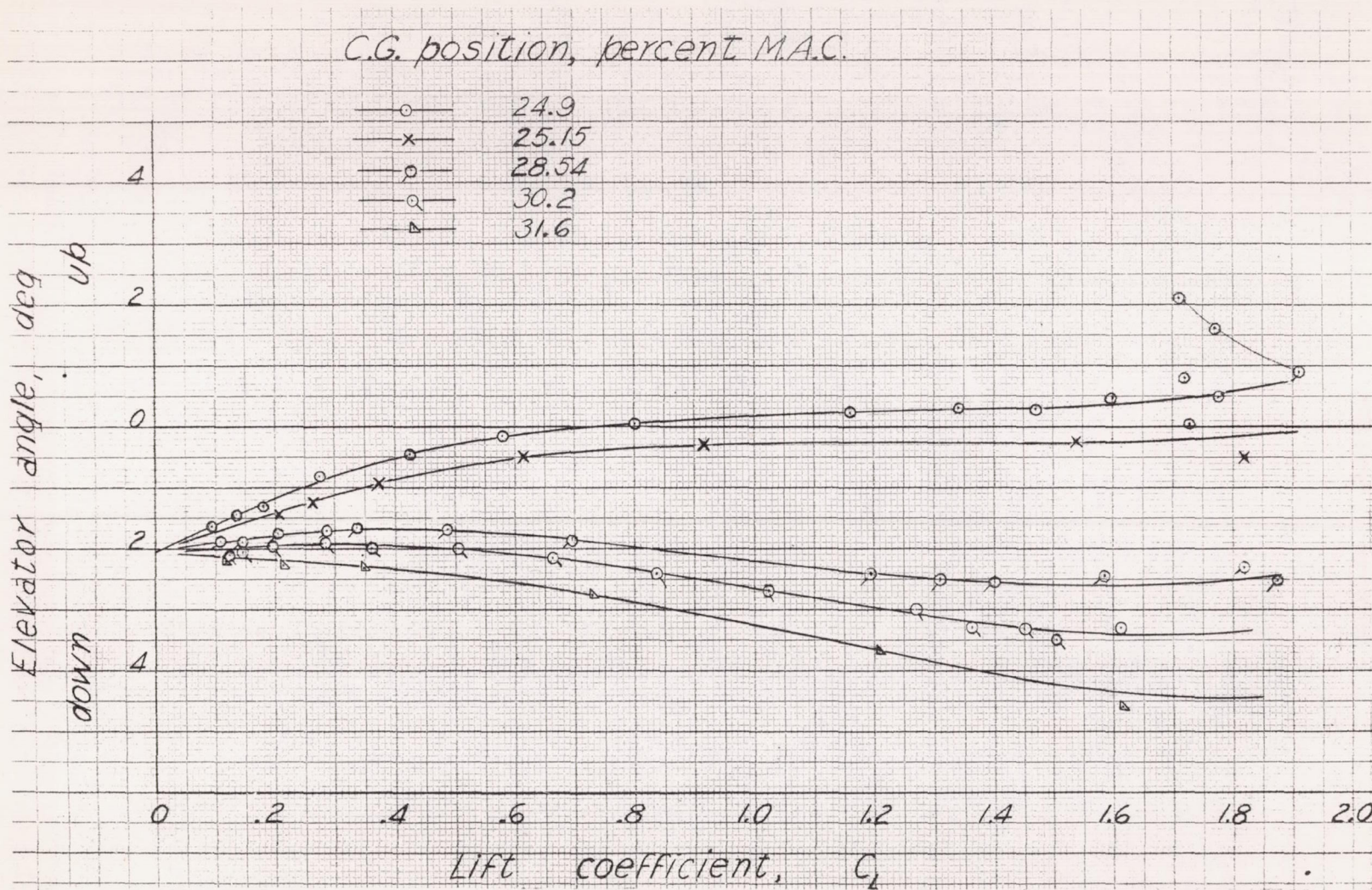

Figure 17.- Variation of elevator angle measured from thrust axis with lift coefficient in the climbing condition (flaps up, landing gear up, rated power) Curtiss SB2C-1 airplane.

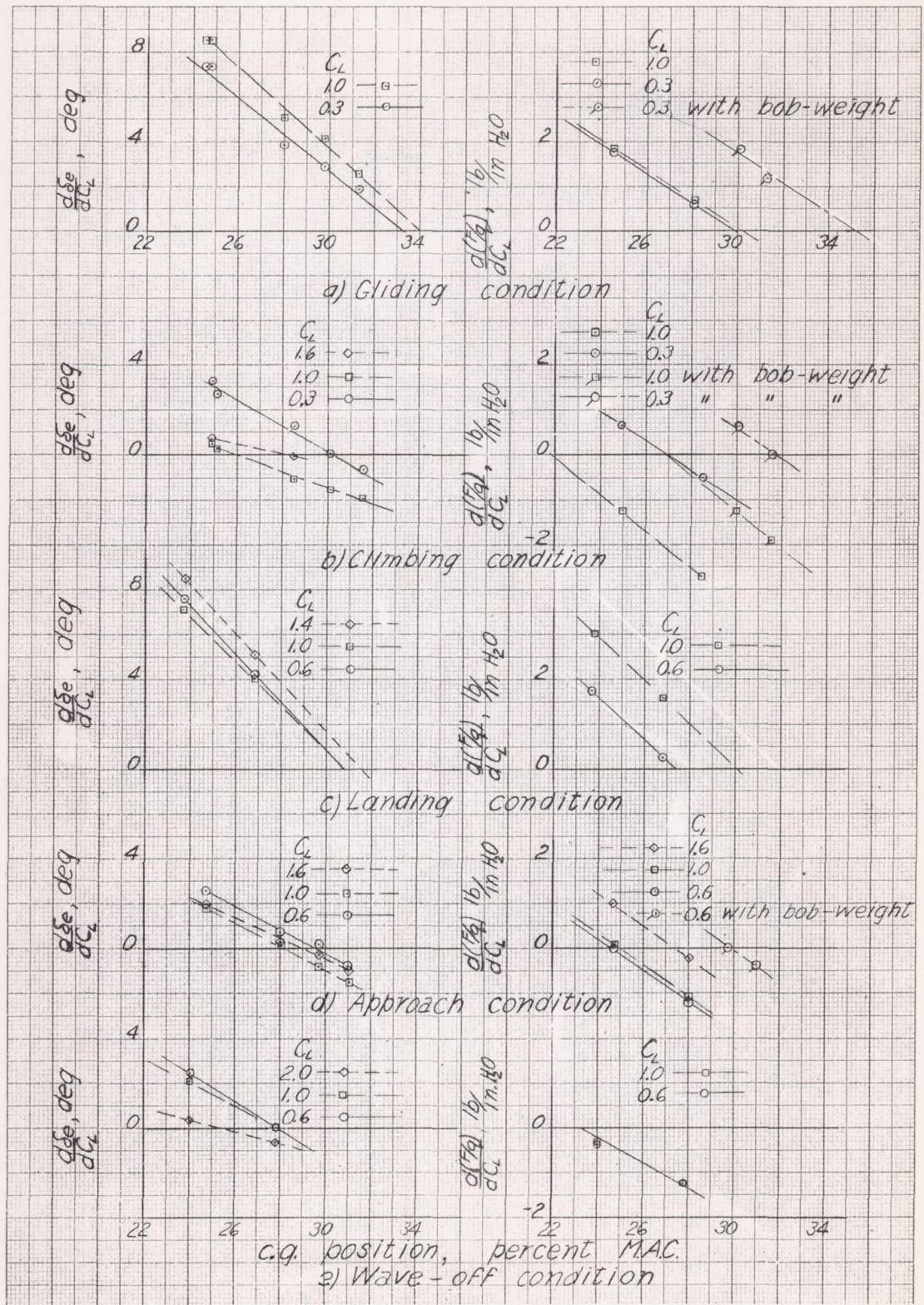

Figure 18.- Plots showing stick-fixed and stick-free neutral points for the various airplane conditions tested. Curtiss SB2C-1 airplane.

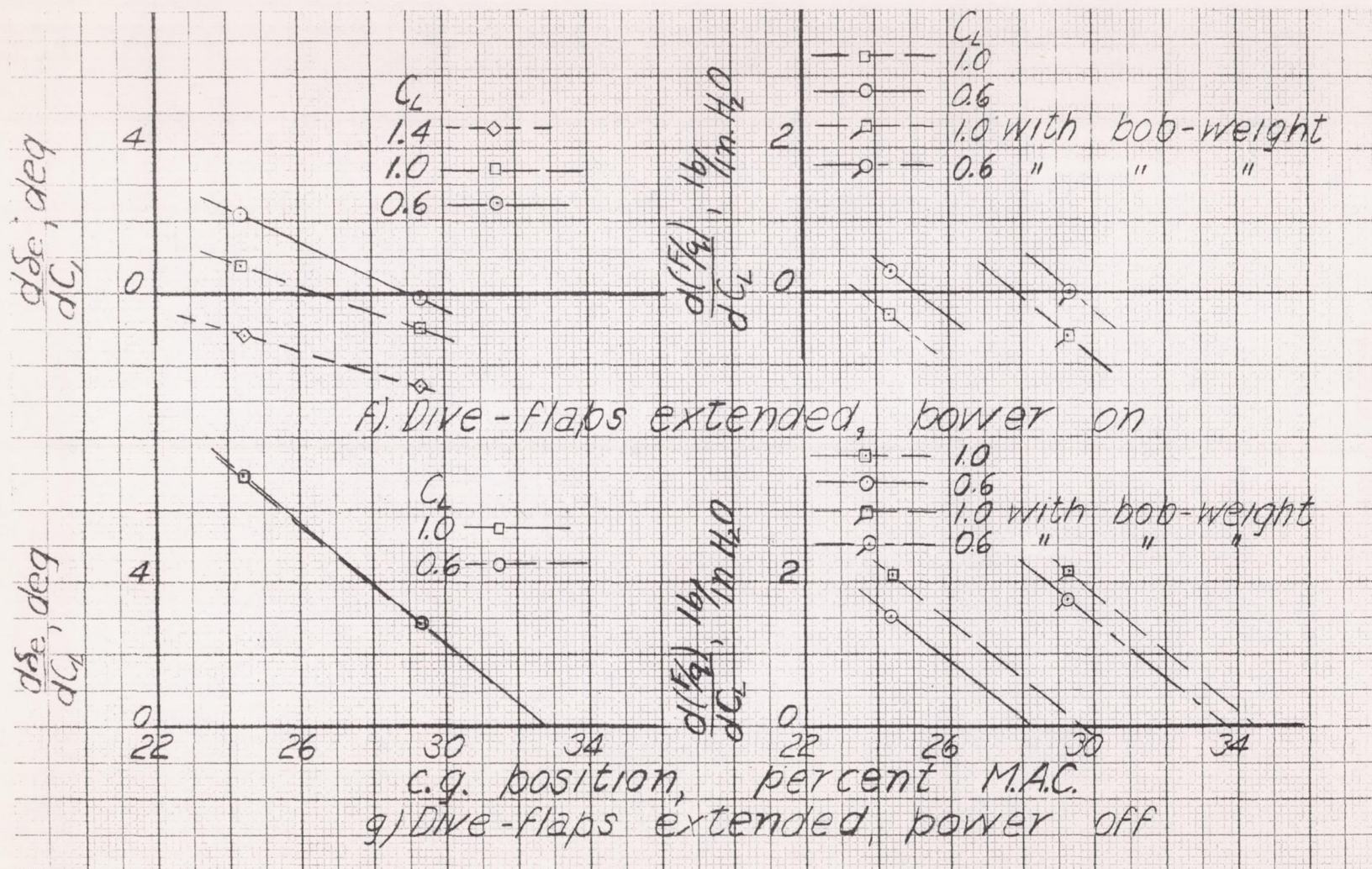

Figure 18.- (concluded) Plots showing stick-fixed and stick-free neutral points for the various airplane conditions tested. Curtiss SB2C-1 airplane.

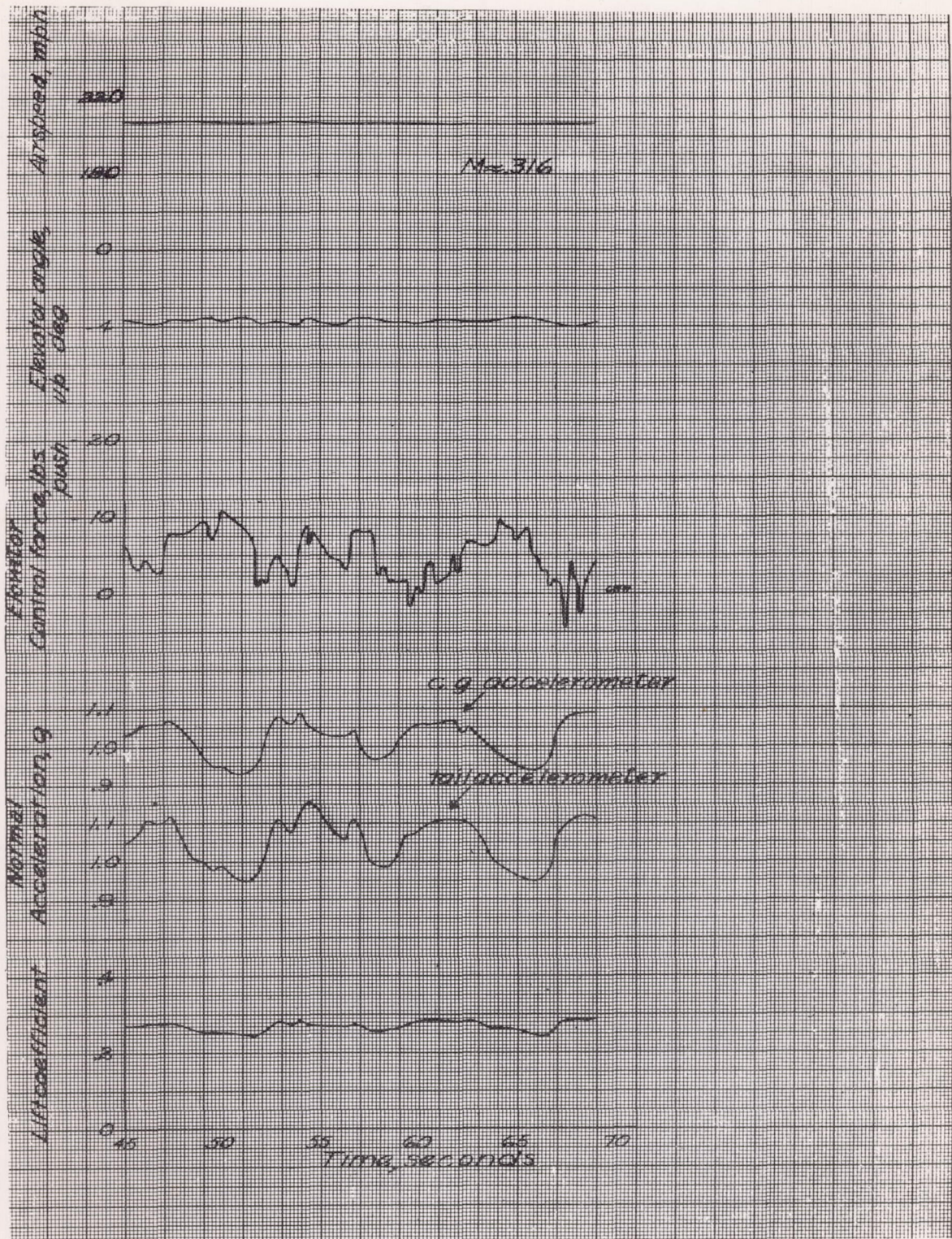

Figure 19.- Time history of straight flight in the gliding condition (flaps up, landing gear up, power off). Note control force variation used by pilot in holding a speed of 207 miles per hour. Curtiss SB2C-1 airplane Nc. OC140.

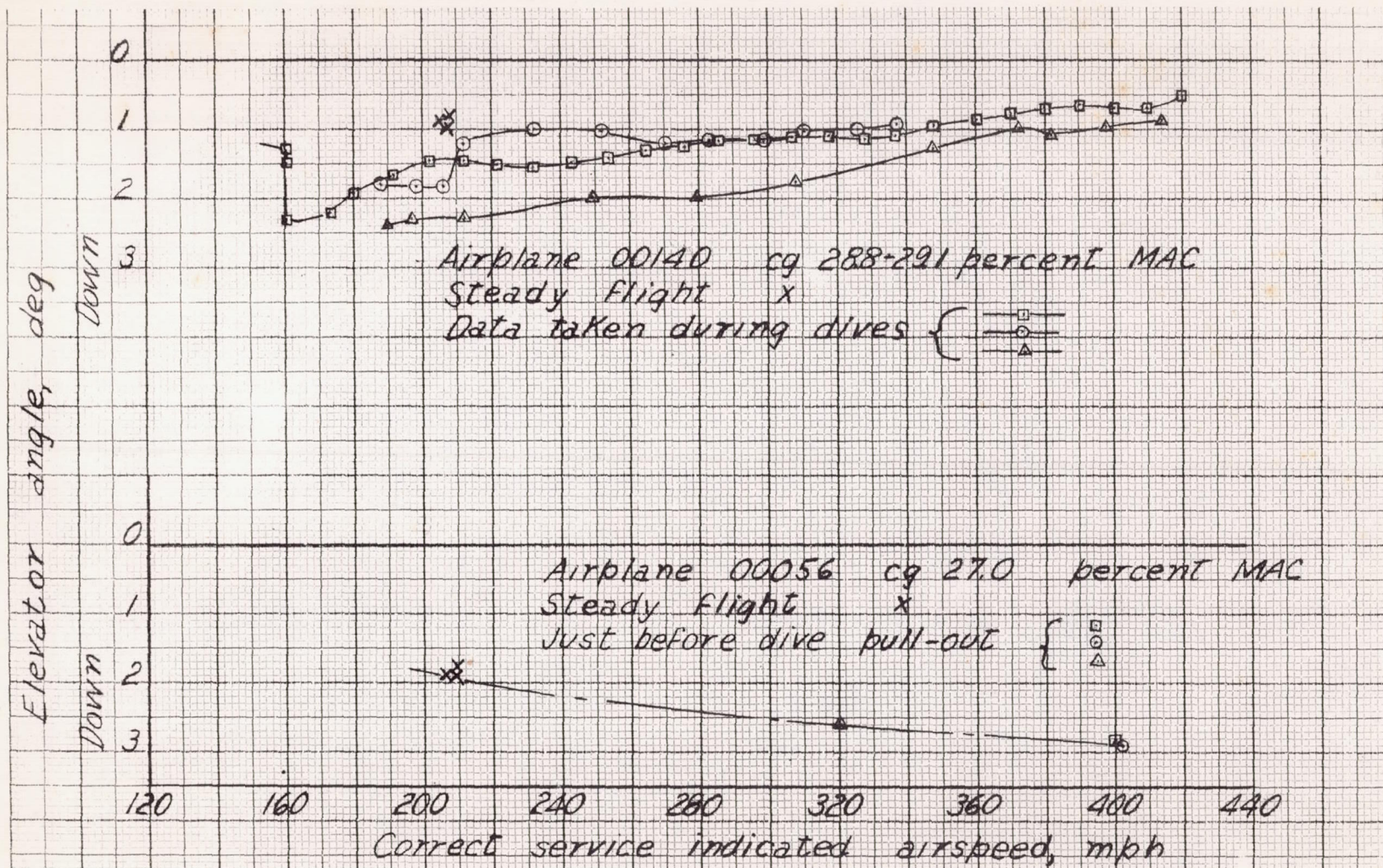

Figure 20.- Variation of elevator angle with speed in dives. Curtiss SB2C-1 airplane, flaps up, landing gear up, front hood open, rear hood closed, power off.

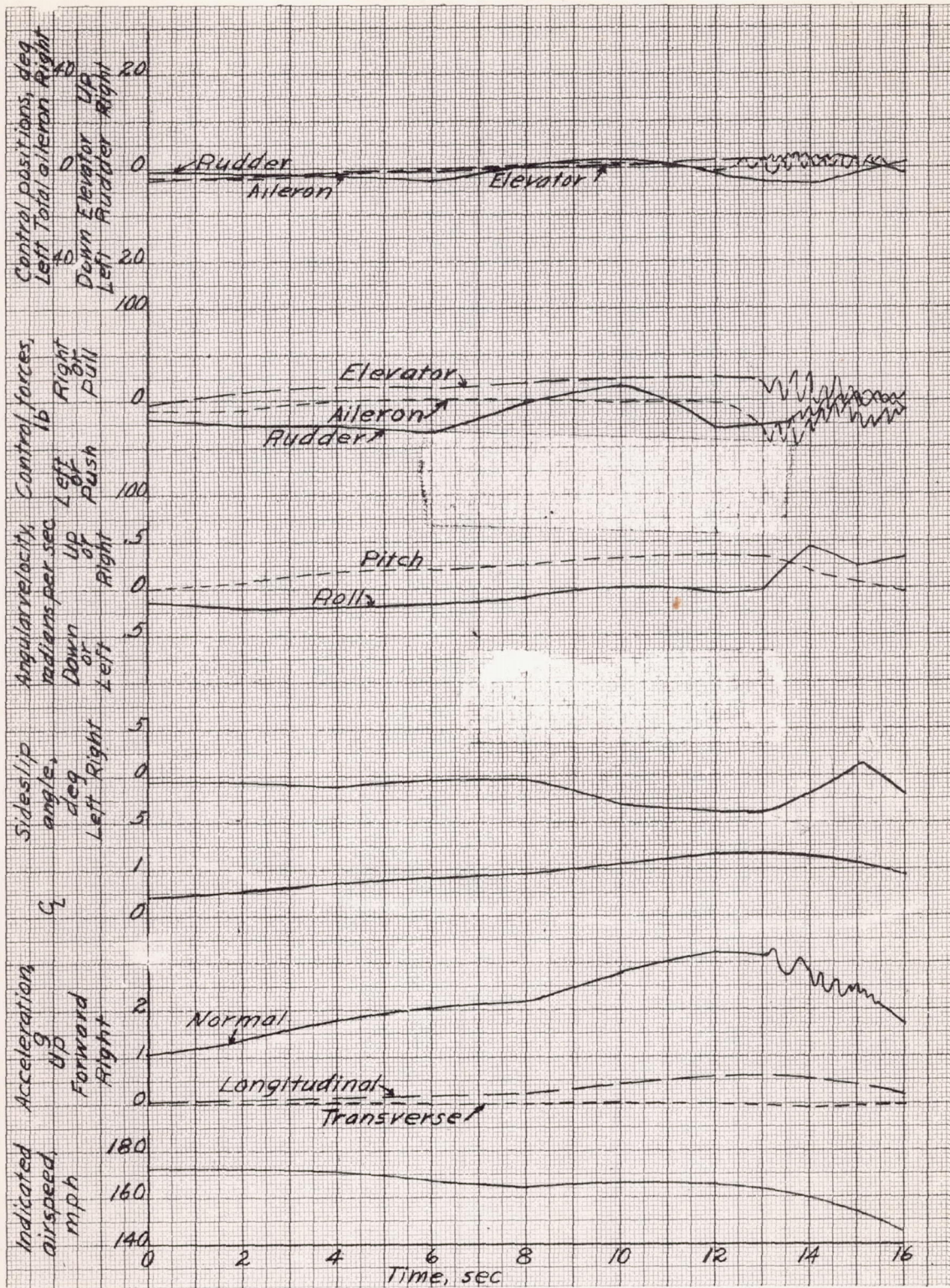

Figure 21.- Time history of a left turn started at 172 miles per hour in which a stall occurred (flaps up, landing gear up, hoods closed, cowl flaps closed, power for level flight). Center of gravity at 31.3 percent of the mean aerodynamic chord, bobweight installed. Curtiss SB2C-1 airplane.

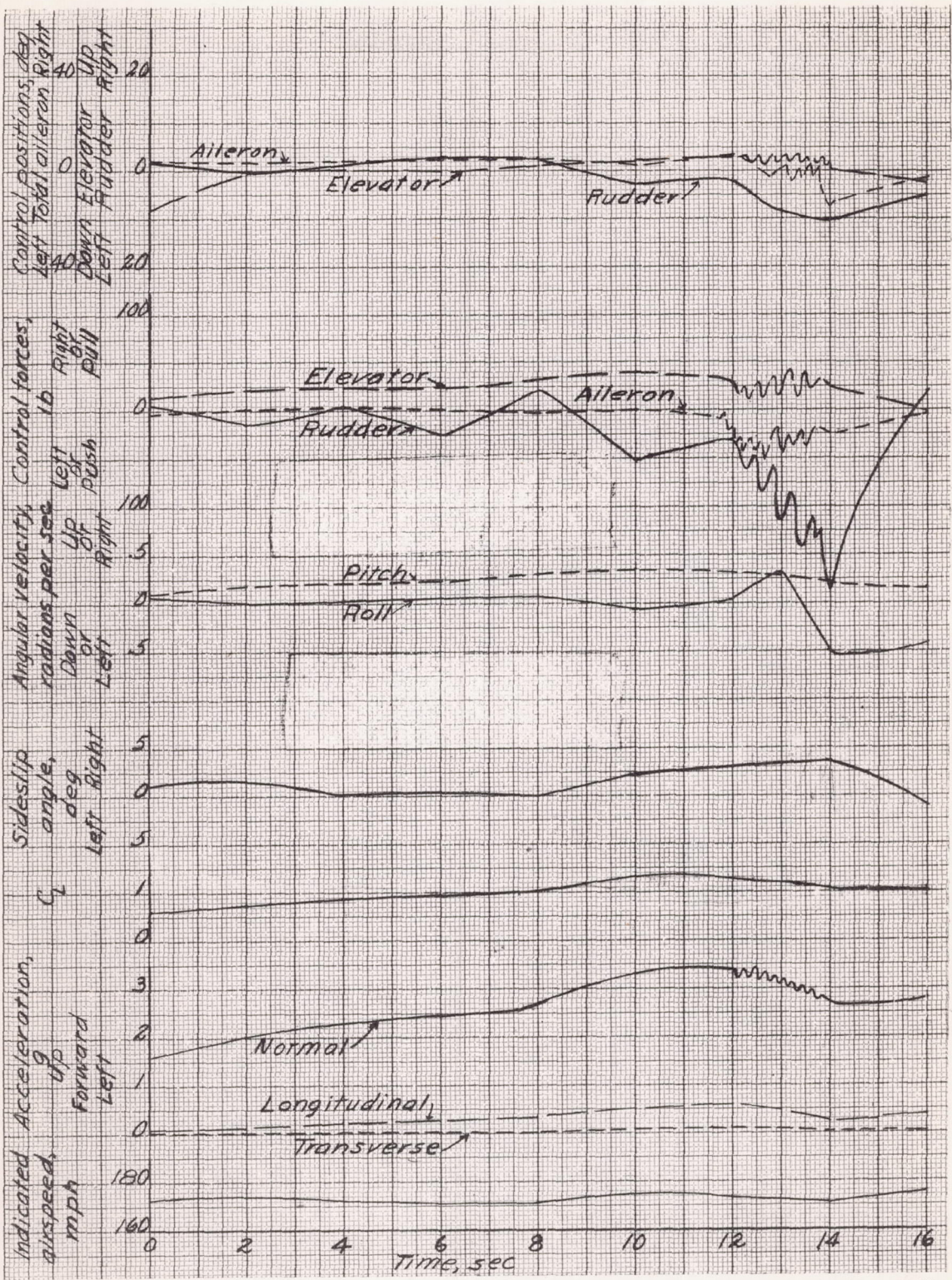

Figure 22.- Time history of a right turn started at 173 miles per hour in which a stall occurred (flaps up, landing gear up, hoods closed, cowl flaps closed, power for level flight). Center of gravity at 31.3 percent of the mean aerodynamic chord, bobweight installed. Curtiss SB2C-1 airplane.

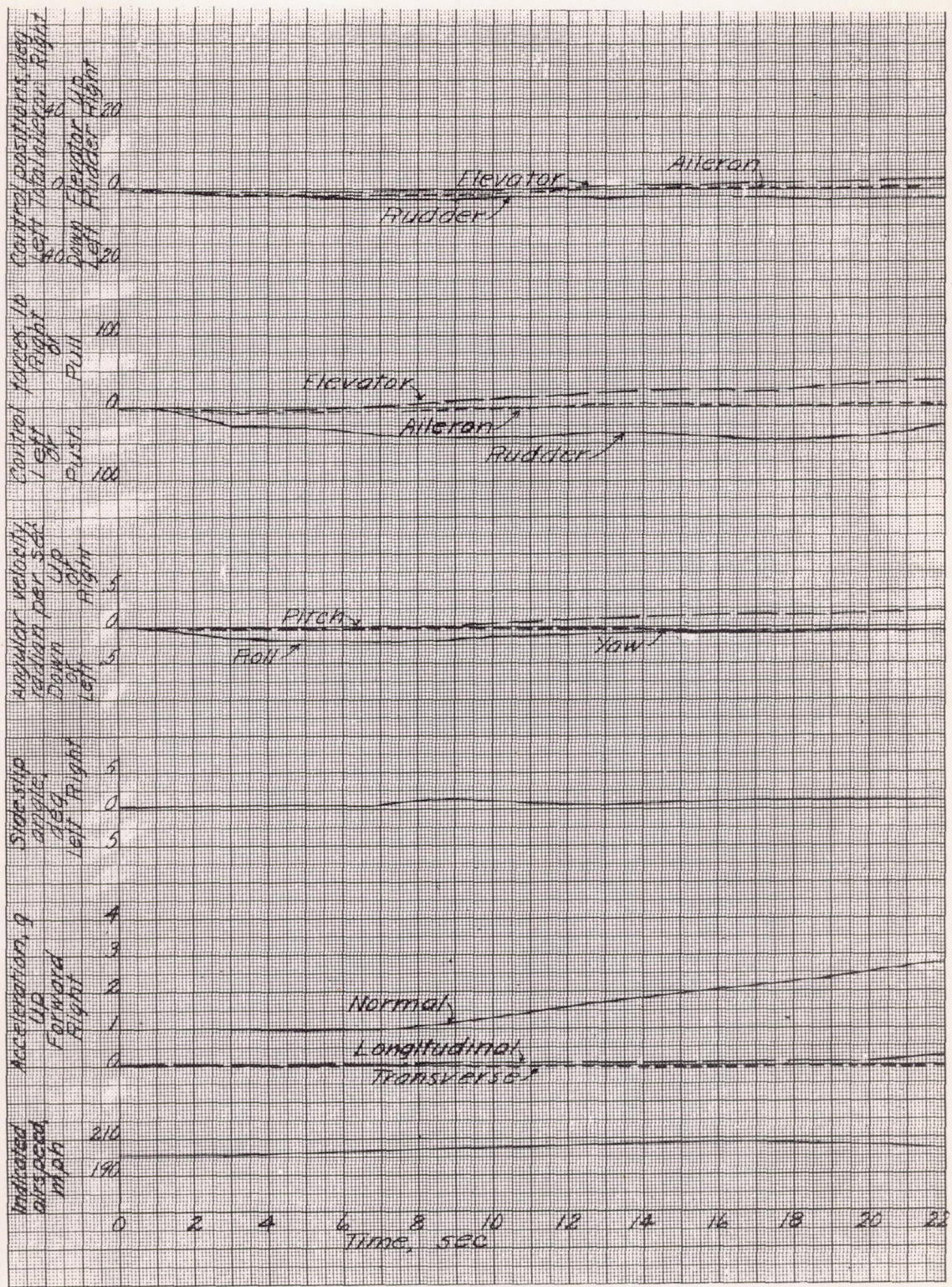

Figure 23.- Time history of a steady turn started at 201 miles per hour. Curtiss B2C-1 airplane (flaps up, landing gear up, hoods closed, cowl flaps closed, power for level flight) center of gravity at 24.1 percent of the mean aerodynamic chord, no bobweight.

L-571

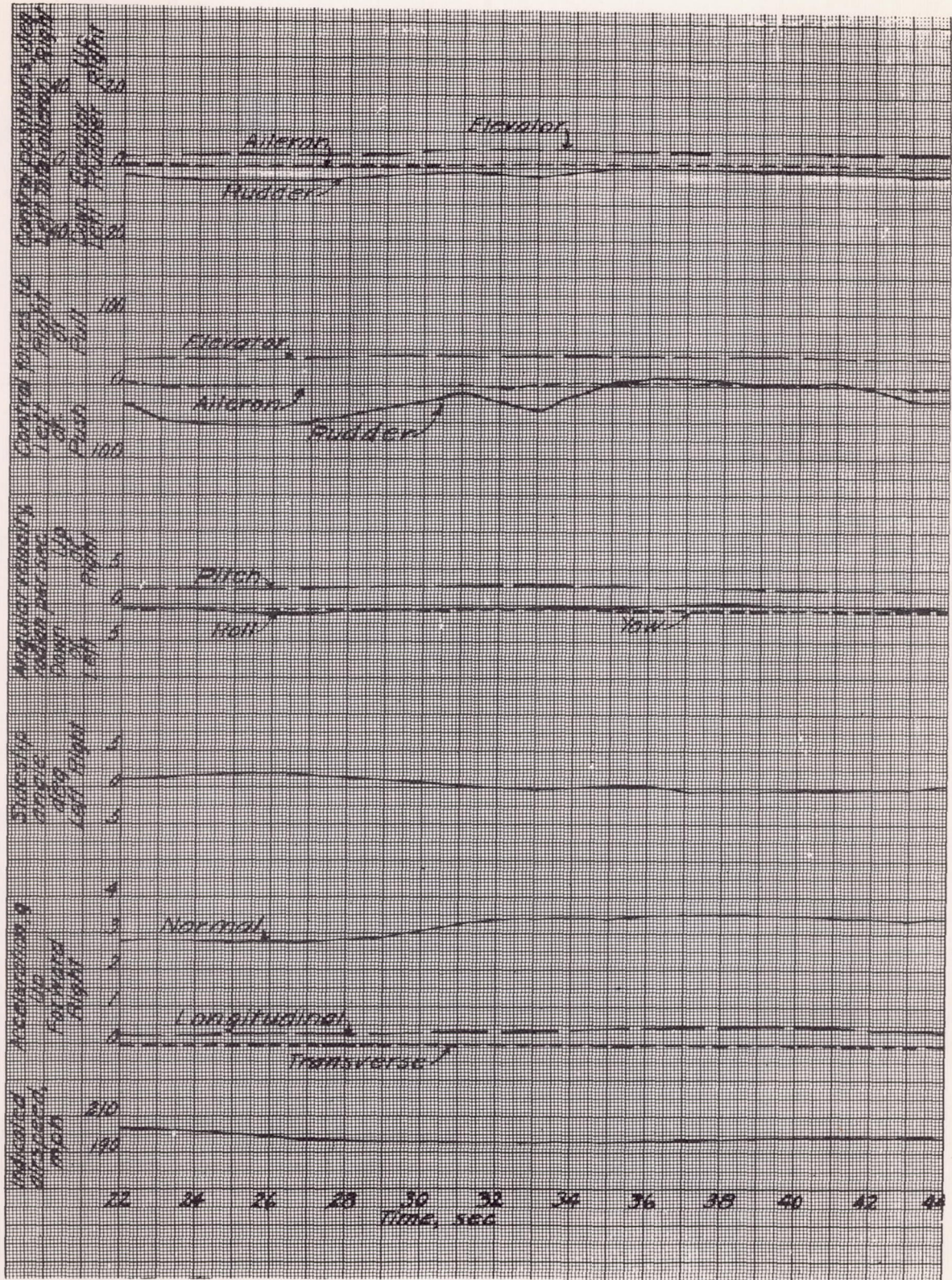

Figure 23.- Concluded.

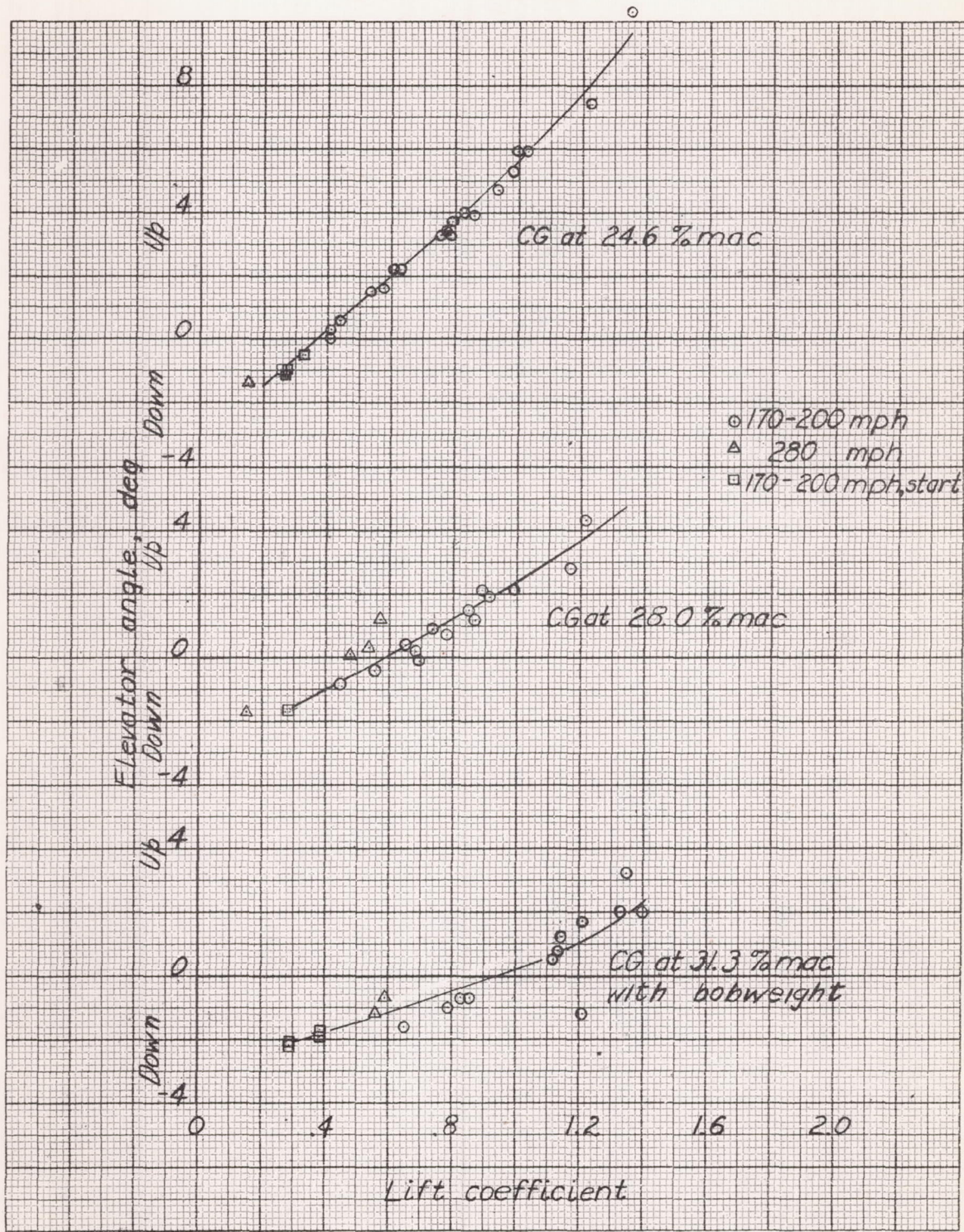

Figure 24.- Variation of elevator angle with lift coefficient in turns. Curtiss SB2C-1 airplane.

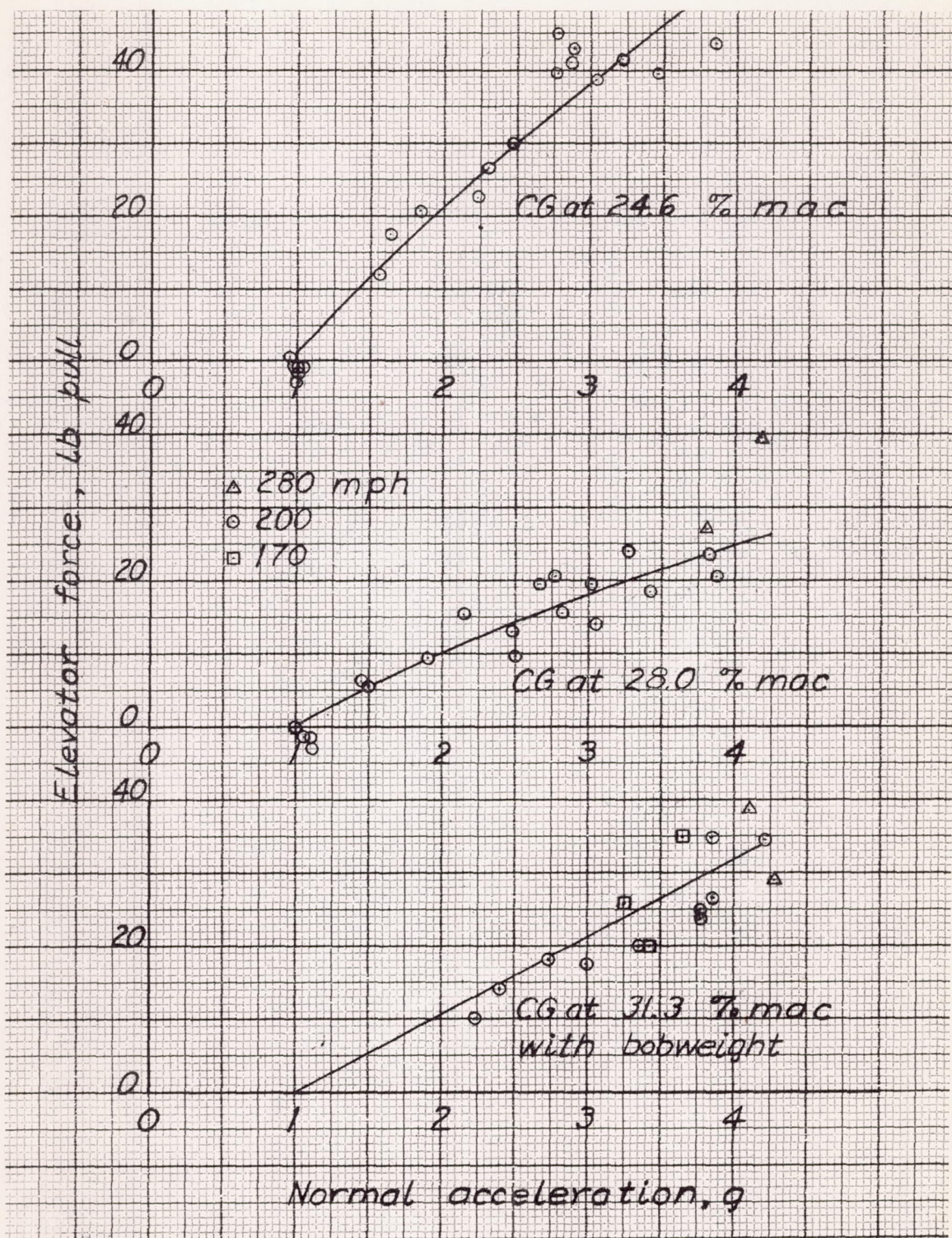

Figure 25.- Variation of elevator force with normal acceleration in turns. Curtiss SB2C-1 airplane.

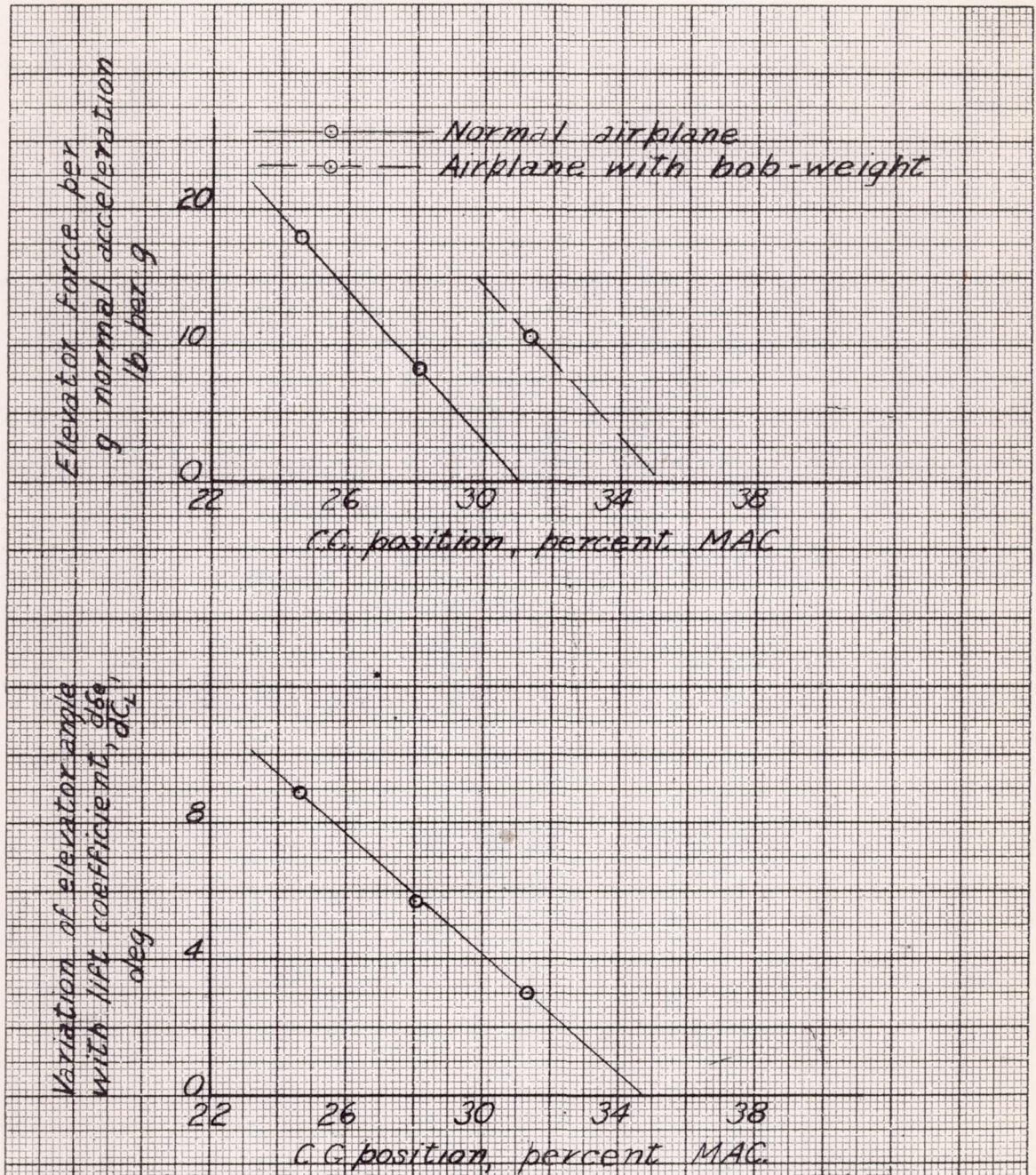

Figure 26.- Characteristics of Curtiss SB2C-1 airplane in steady turns.

L-571

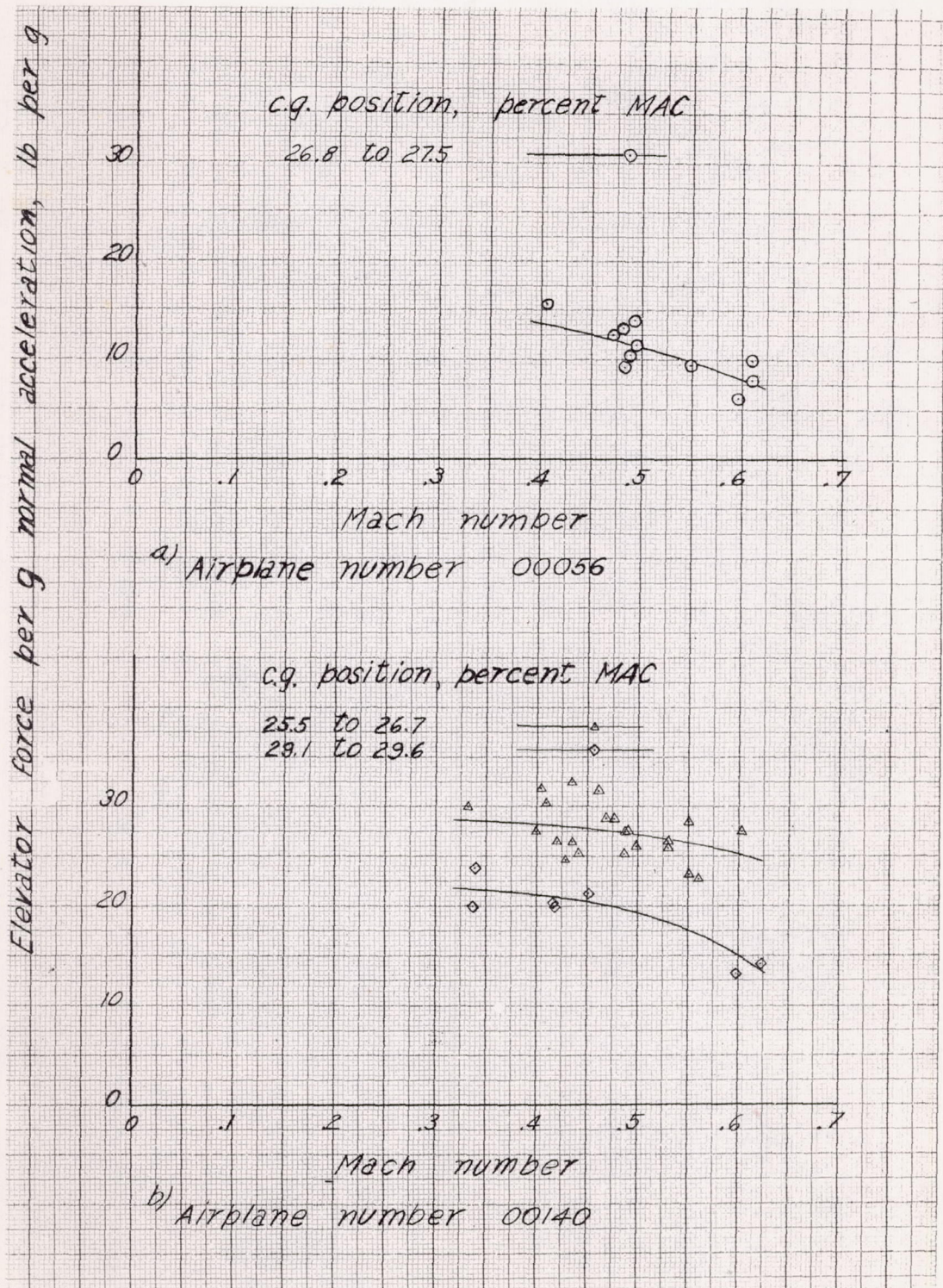

Figure 27.- Variation of elevator force per g normal acceleration with Mach number in pull-outs from dives. Curtiss SB2C-1 airplanes number 00056 and 00140, flaps up, landing gear up, front hood open, rear hood closed, power off.

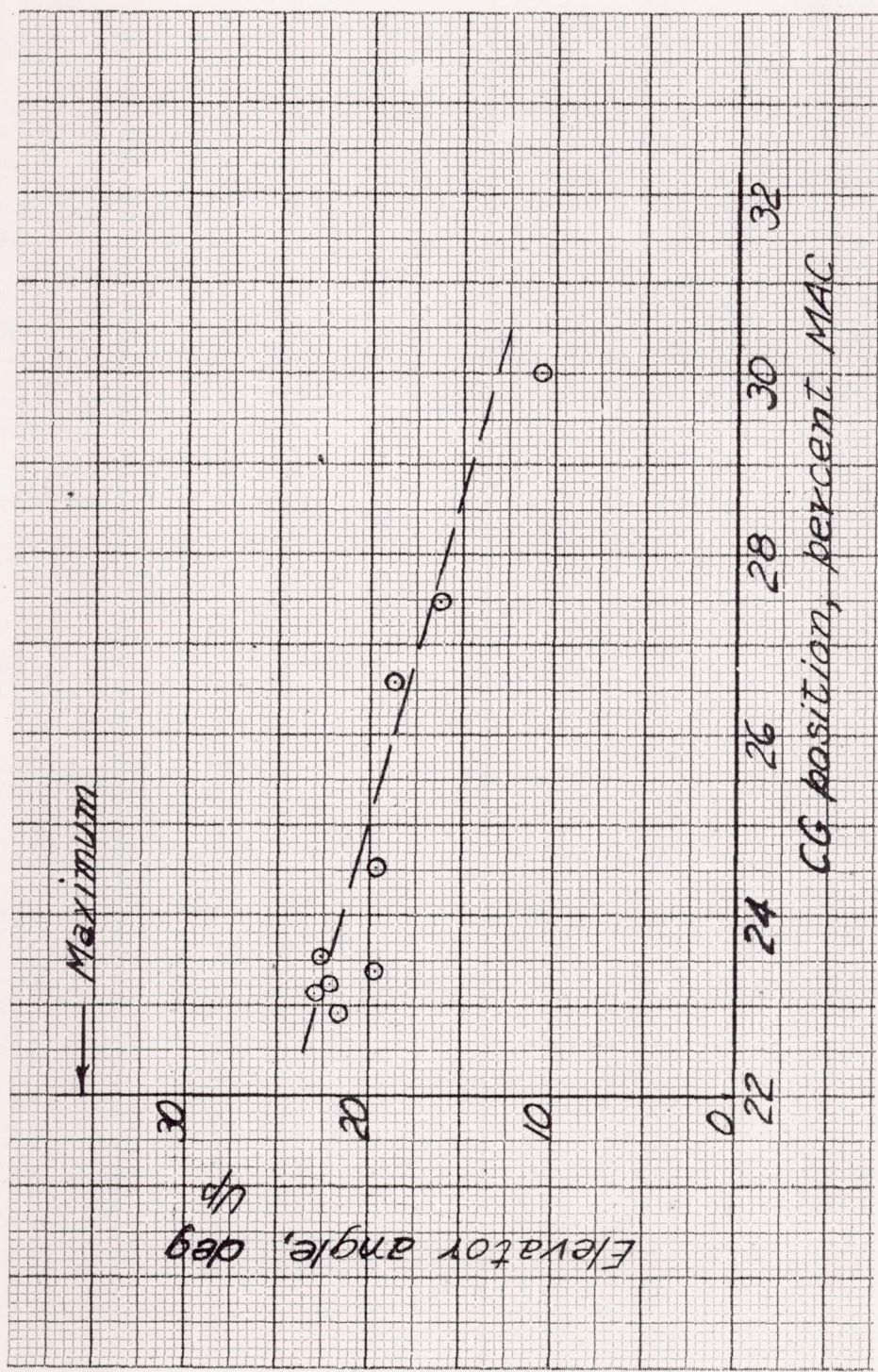

Figure 28.- Variation of elevator angle required to make a three-point landing with center-of-gravity position. Curtiss SB2C-1 airplane.

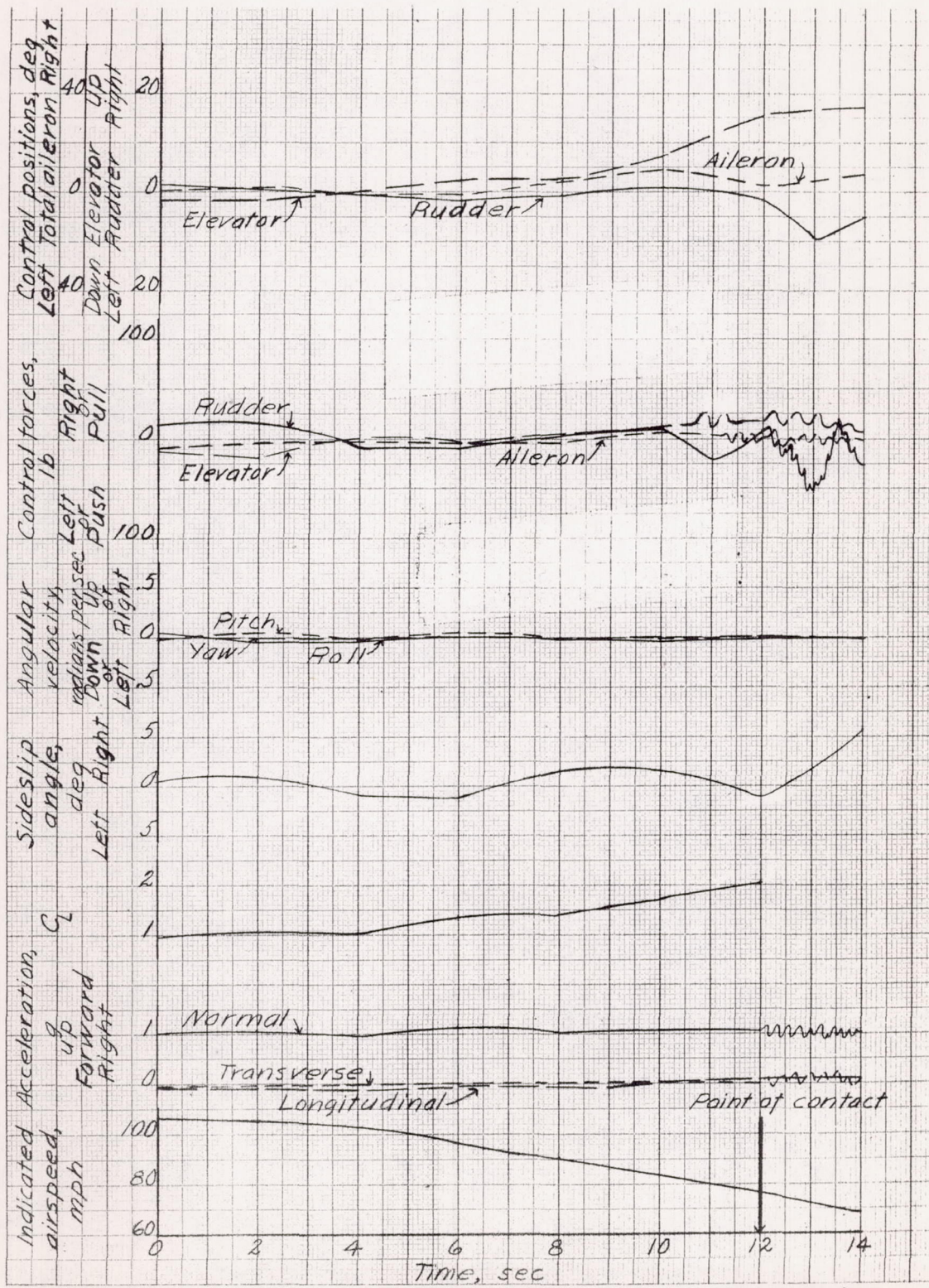

Figure 29.- Time history of a three-point landing (flaps down, landing gear down, power off). Center of gravity at 27.2 percent of the mean aerodynamic chord. Curtiss SB2C-1 airplane.

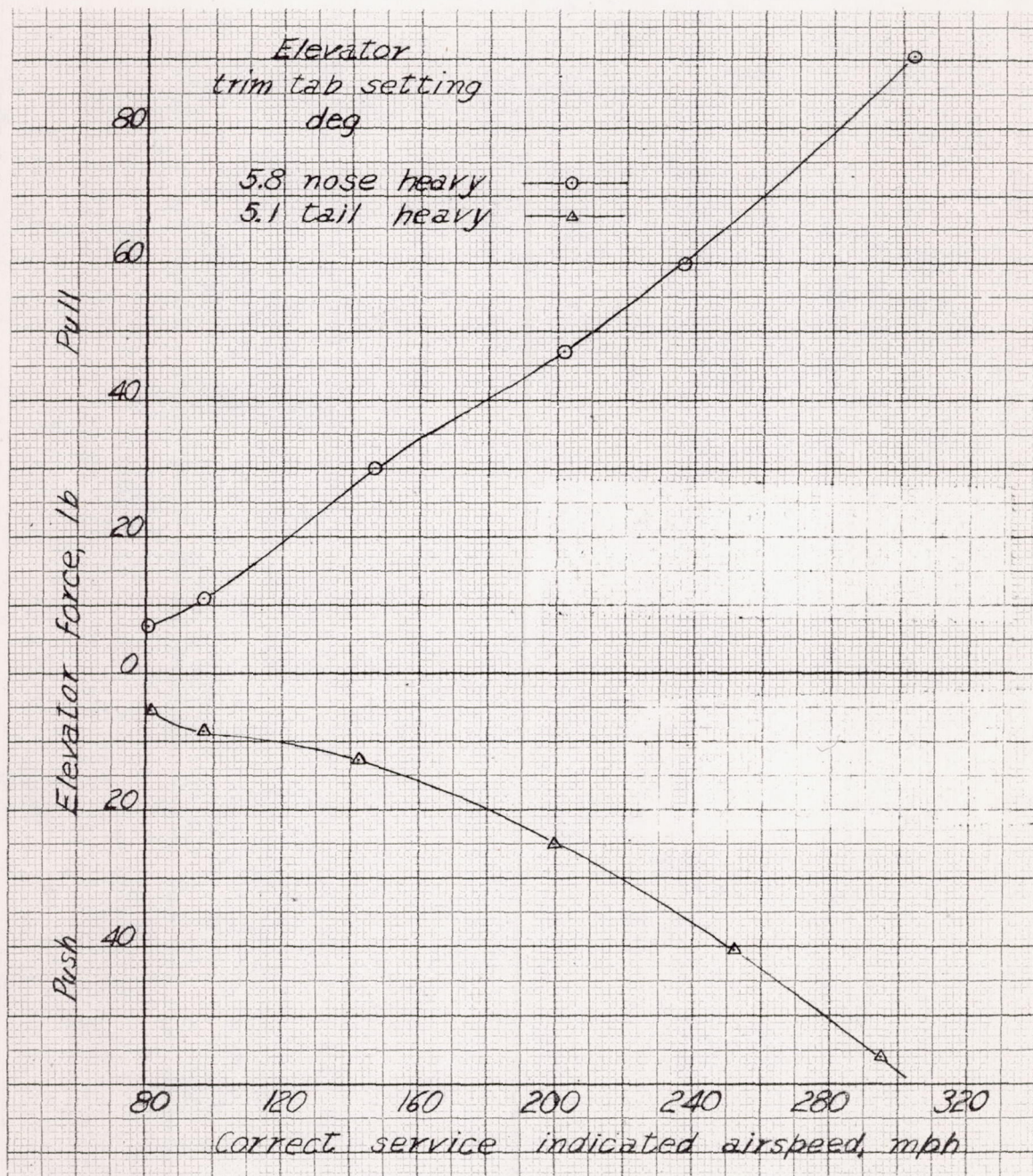
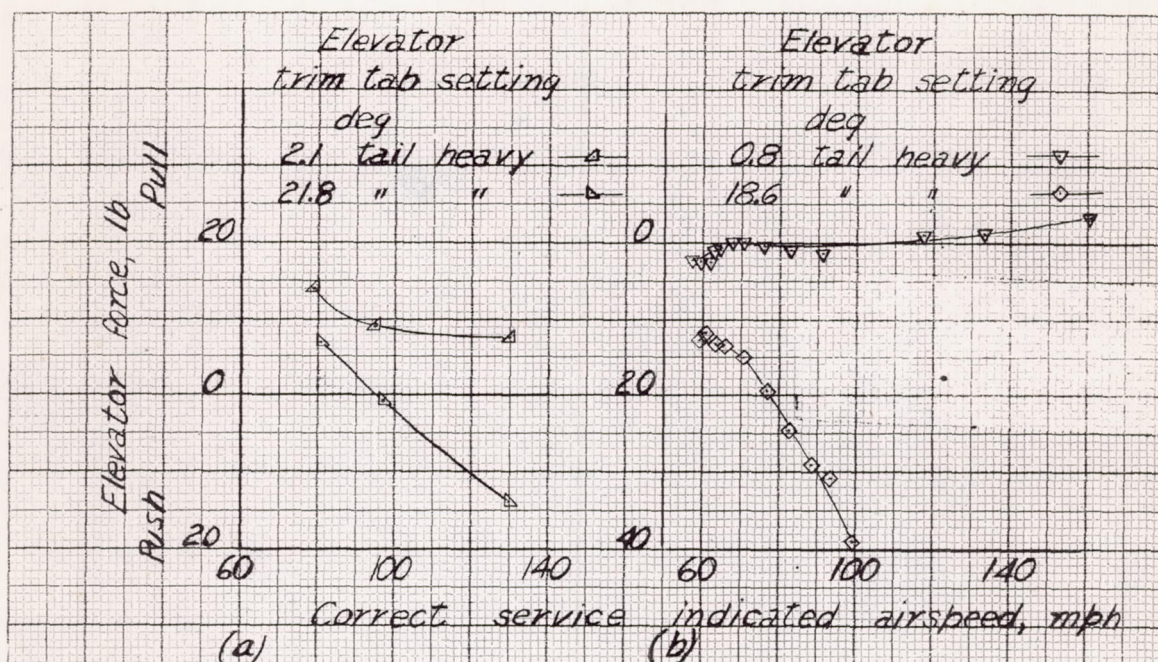

Figure 30.- Variation of elevator force with speed for two trim tab settings in the climbing condition (flaps up, landing gear up, rated power) Curtiss SB2C-1 airplane.

L-571



- (a) Landing condition (flaps down, landing gear down, power off).
- (b) Wave-off condition (flaps down, landing gear down, full power).

Figure 31.- Variation of elevator force with speed for two trim-tab settings. Curtiss SB2C-1 airplane.

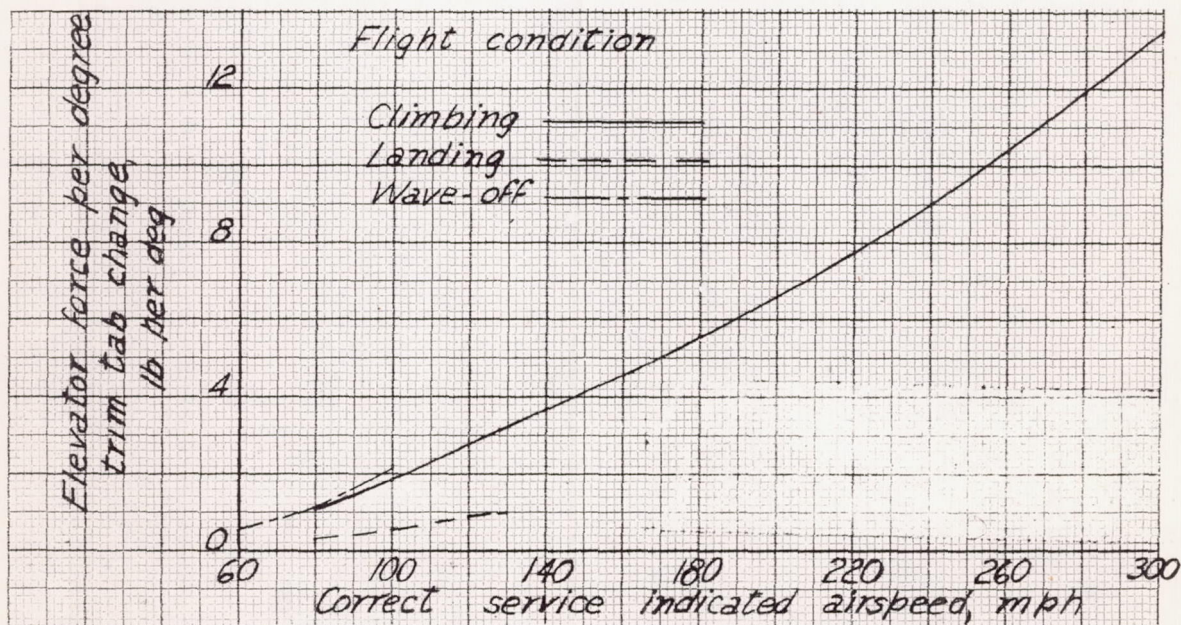

Figure 32.- Variation of power of elevator trim tab with speed. Curtiss SB2C-1 airplane.

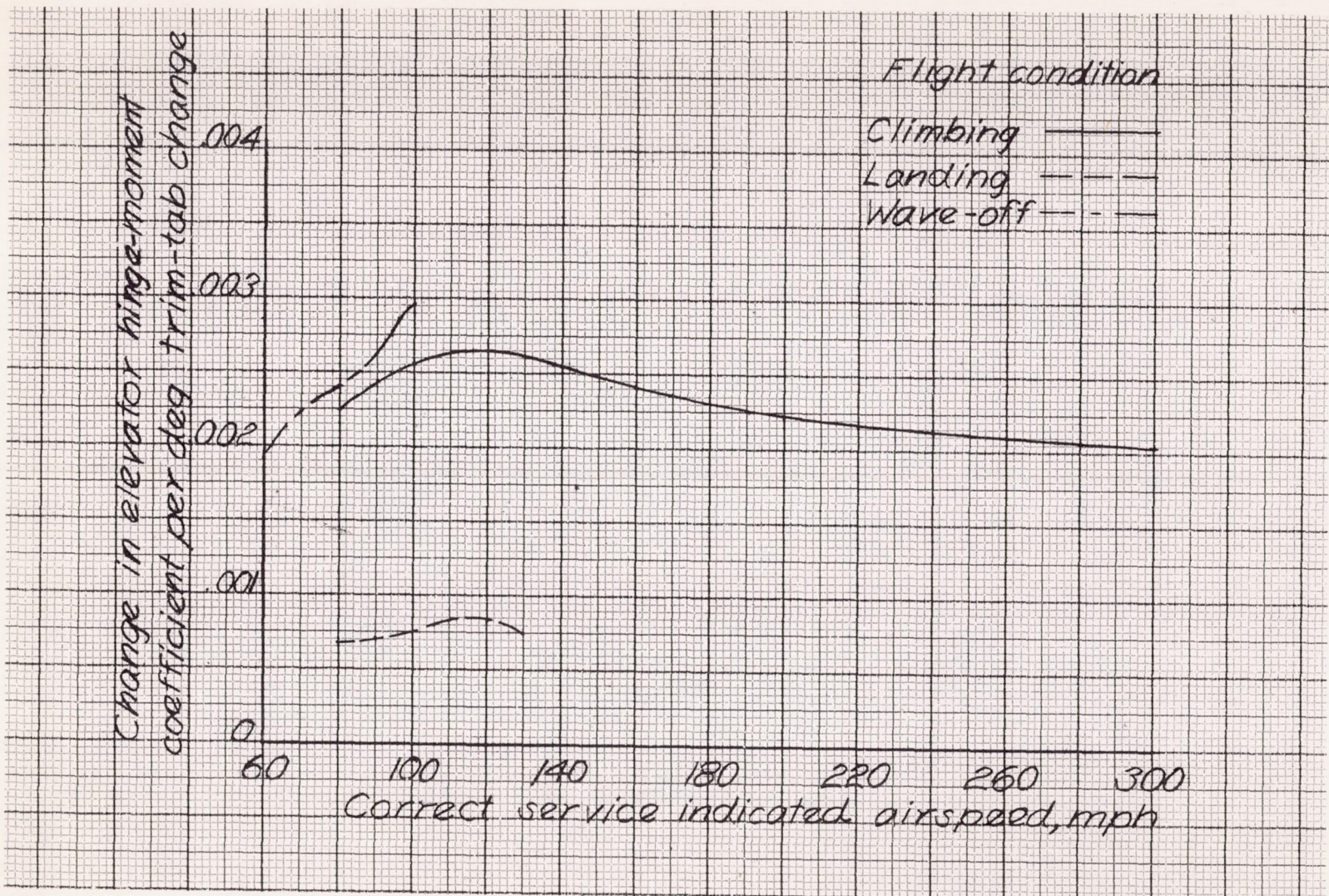

Figure 33.- Variation of change in elevator hinge moment coefficient per degree trim-tab deflection with indicated airspeed. Curtiss SB2C-1 airplane.

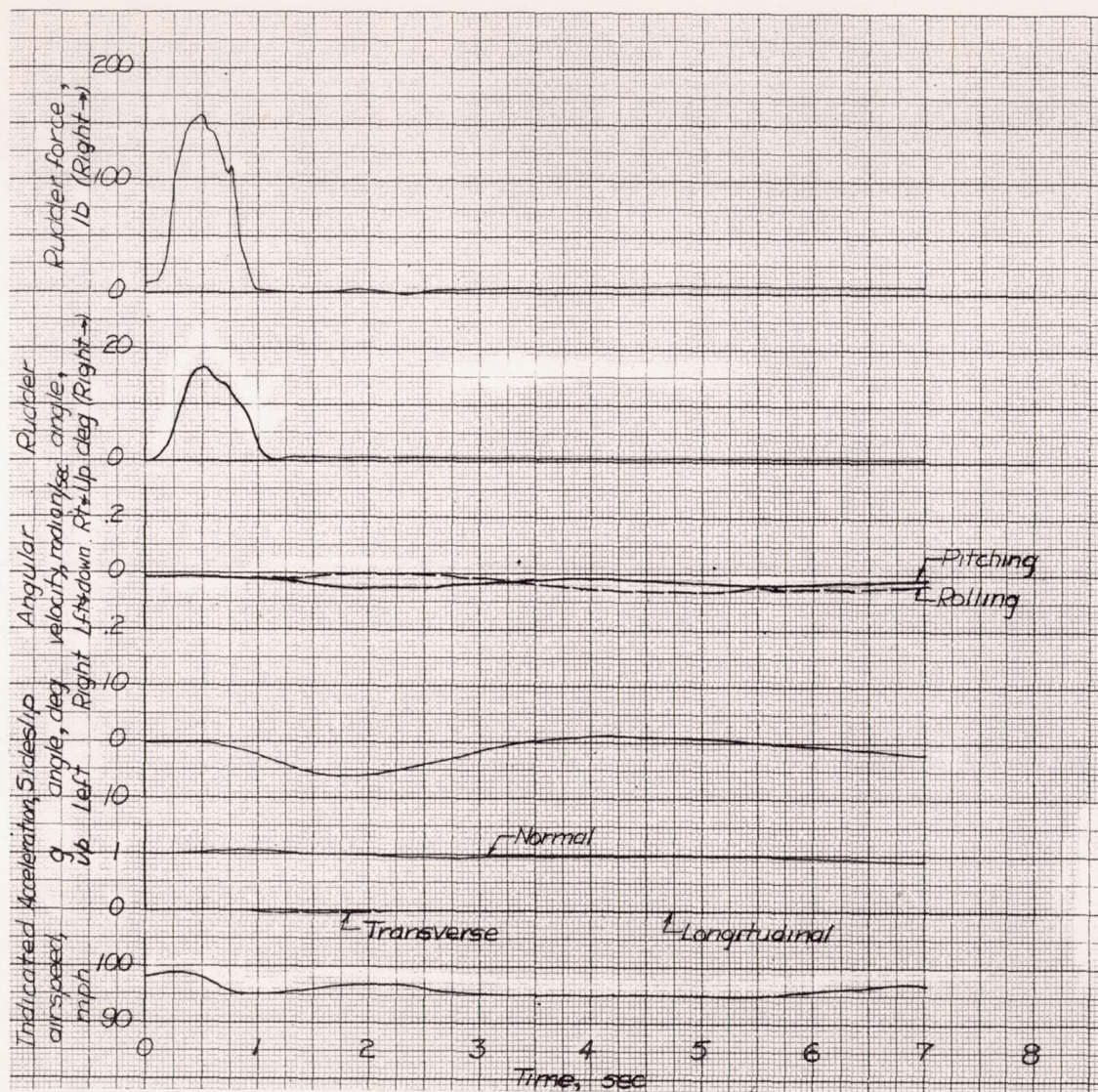

Figure 34.- Time history of a typical lateral oscillation at approximately 98 mph. Curtiss SB2C-1 airplane, flaps up, landing gear up, power off.

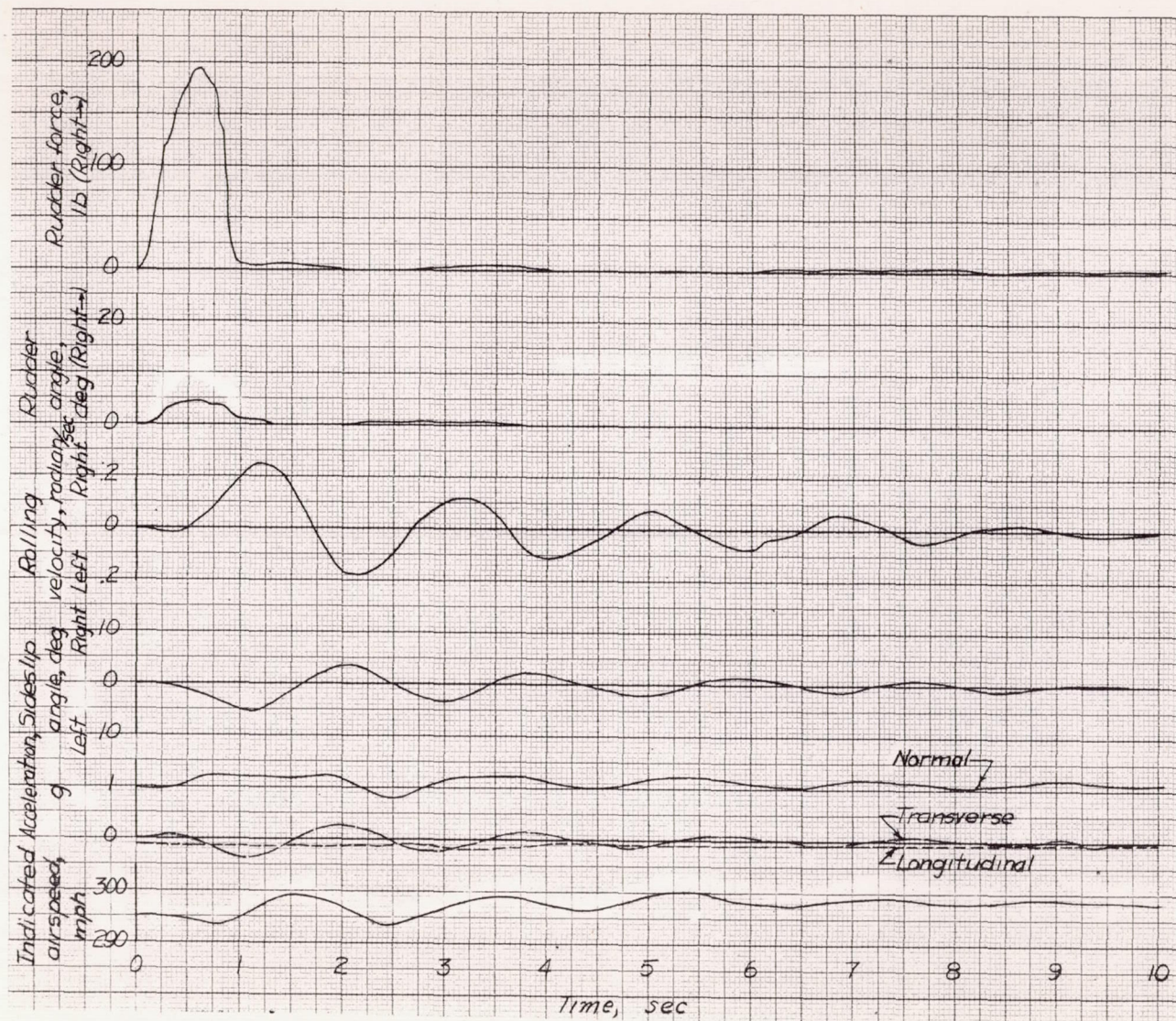

Figure 35.- Time history of a typical lateral oscillation at approximately 295 mph.
Curtiss SB2C-1 airplane, flaps up, landing gear up, rated power.

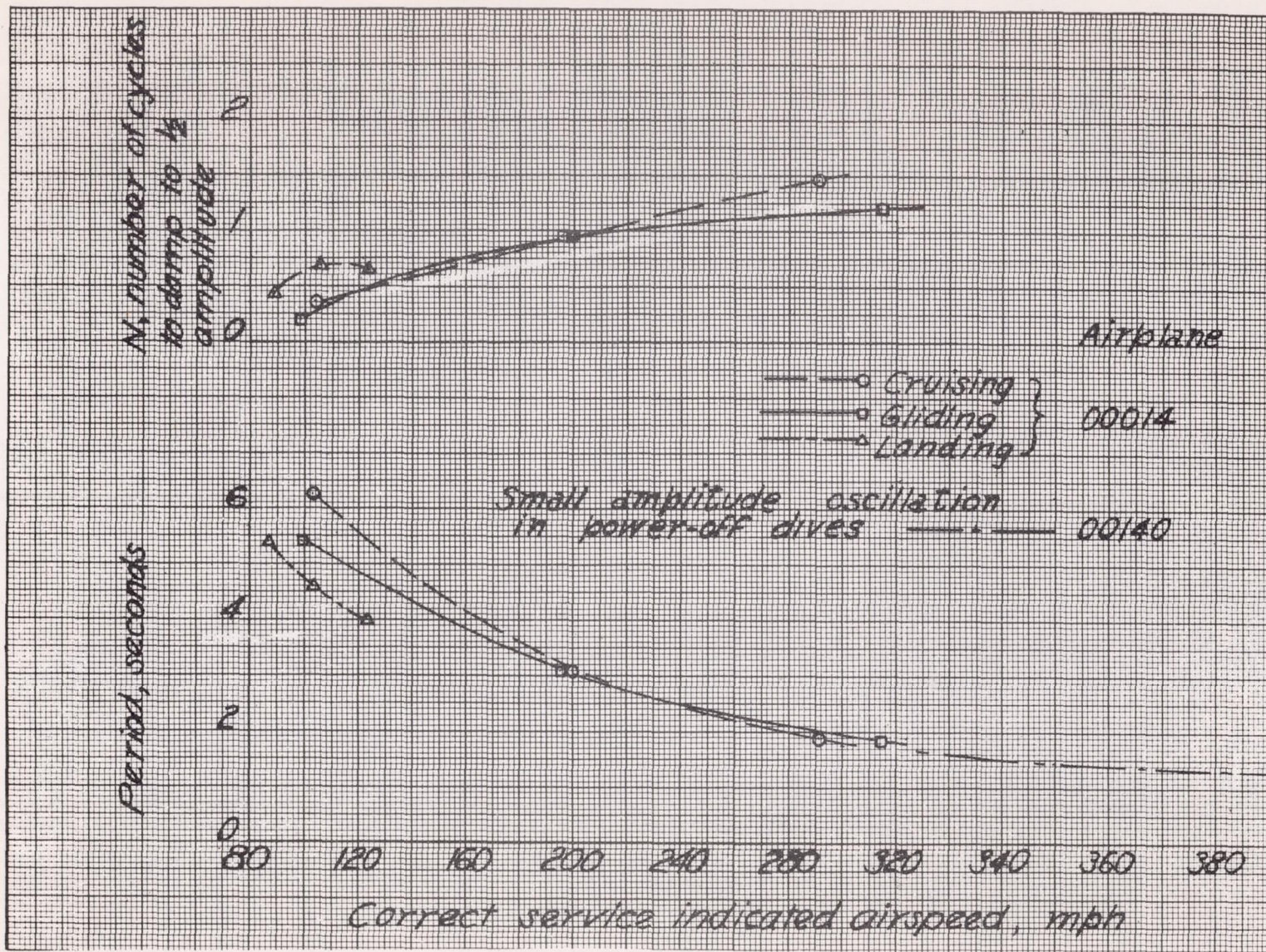

Figure 36.- Period and damping of lateral oscillations. Curtiss SB2C-1 airplane.

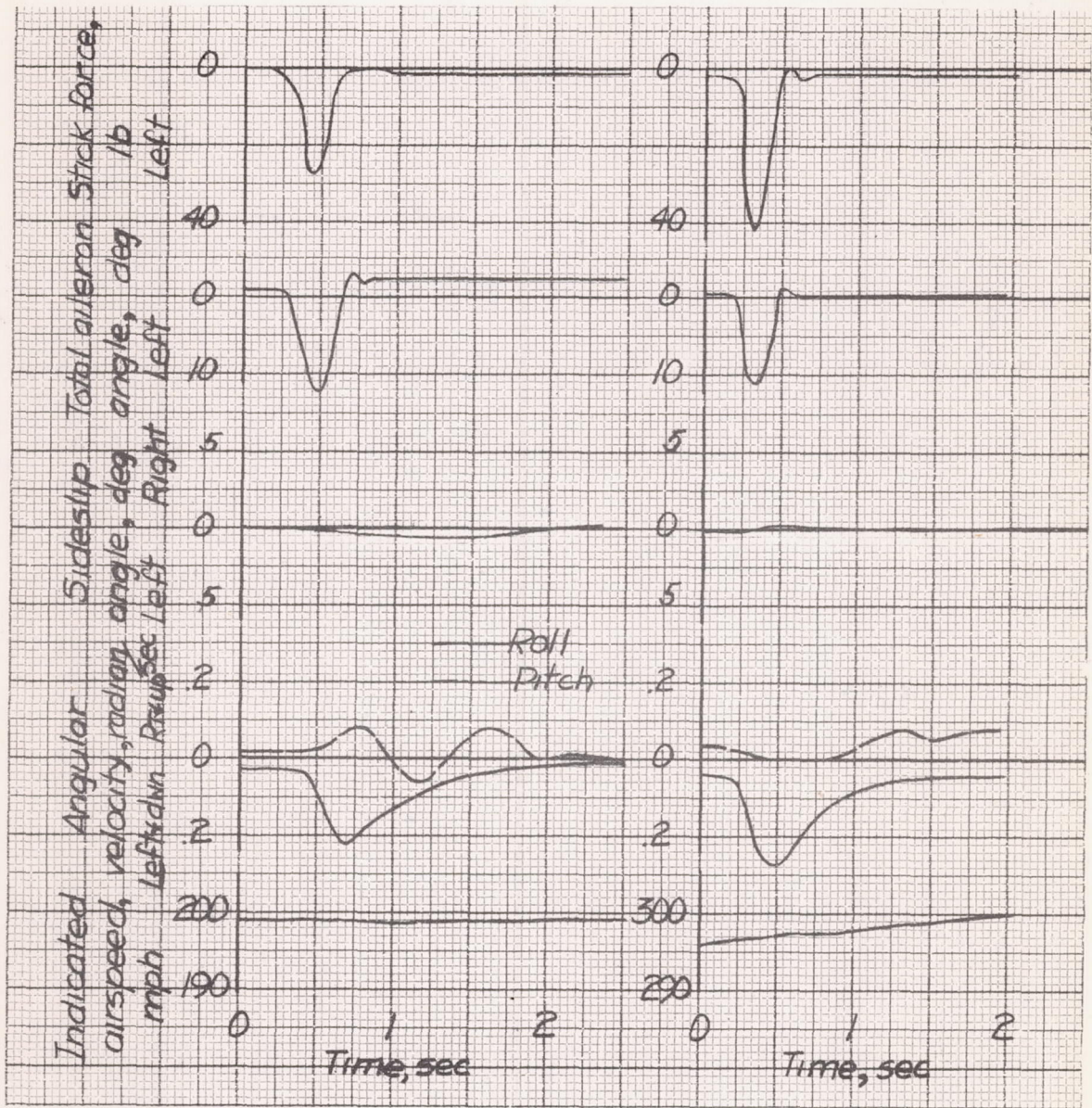

Figure 37.- Time histories of typical attempted aileron oscillations. Curtiss SB2C-1 airplane, flaps up, landing gear up, rated power.

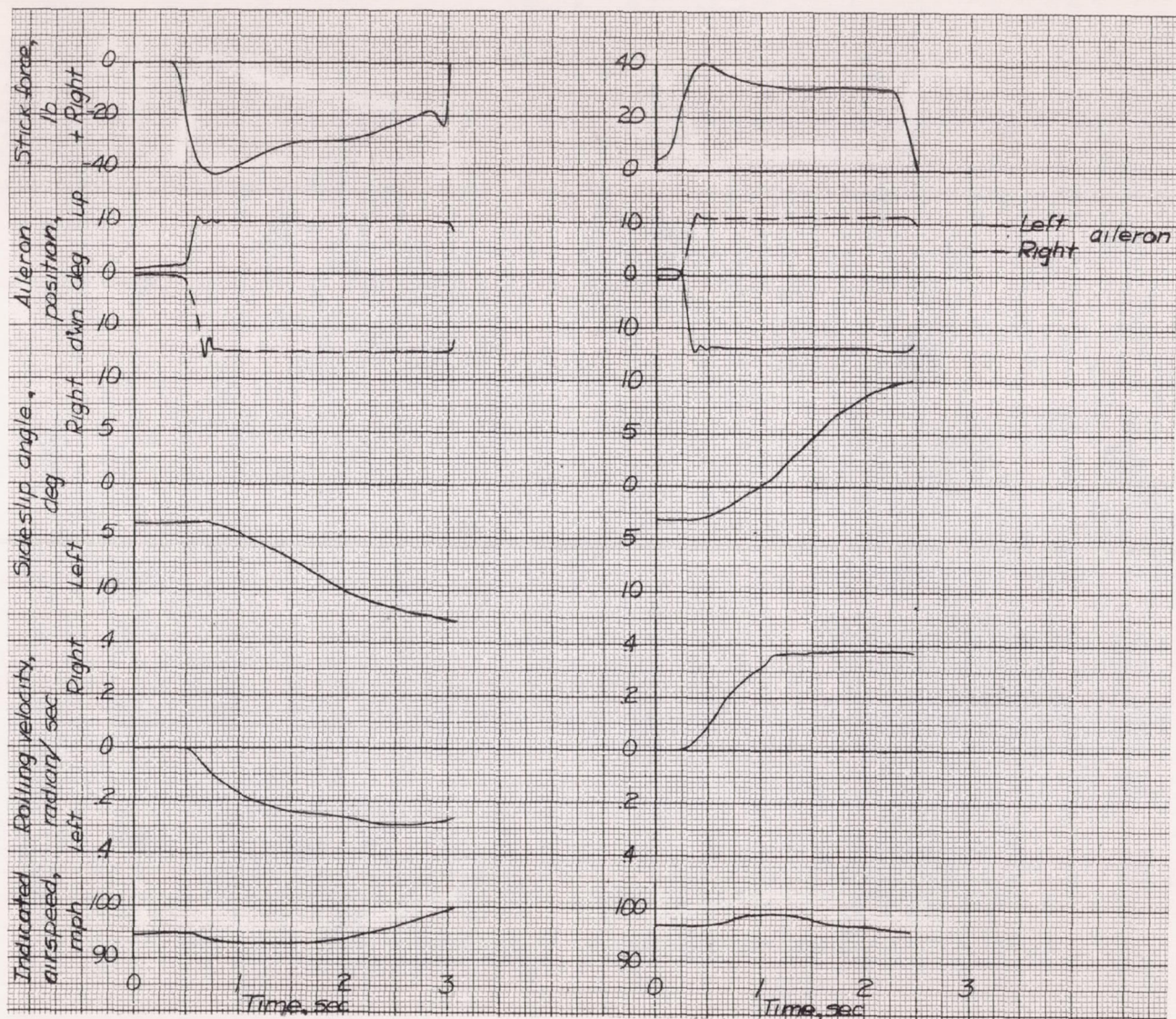

Figure 38.- Time histories of typical abrupt aileron rolls (rudder fixed) Curtiss SB2C-1 airplane, flaps up, landing gear up, power for level flight.

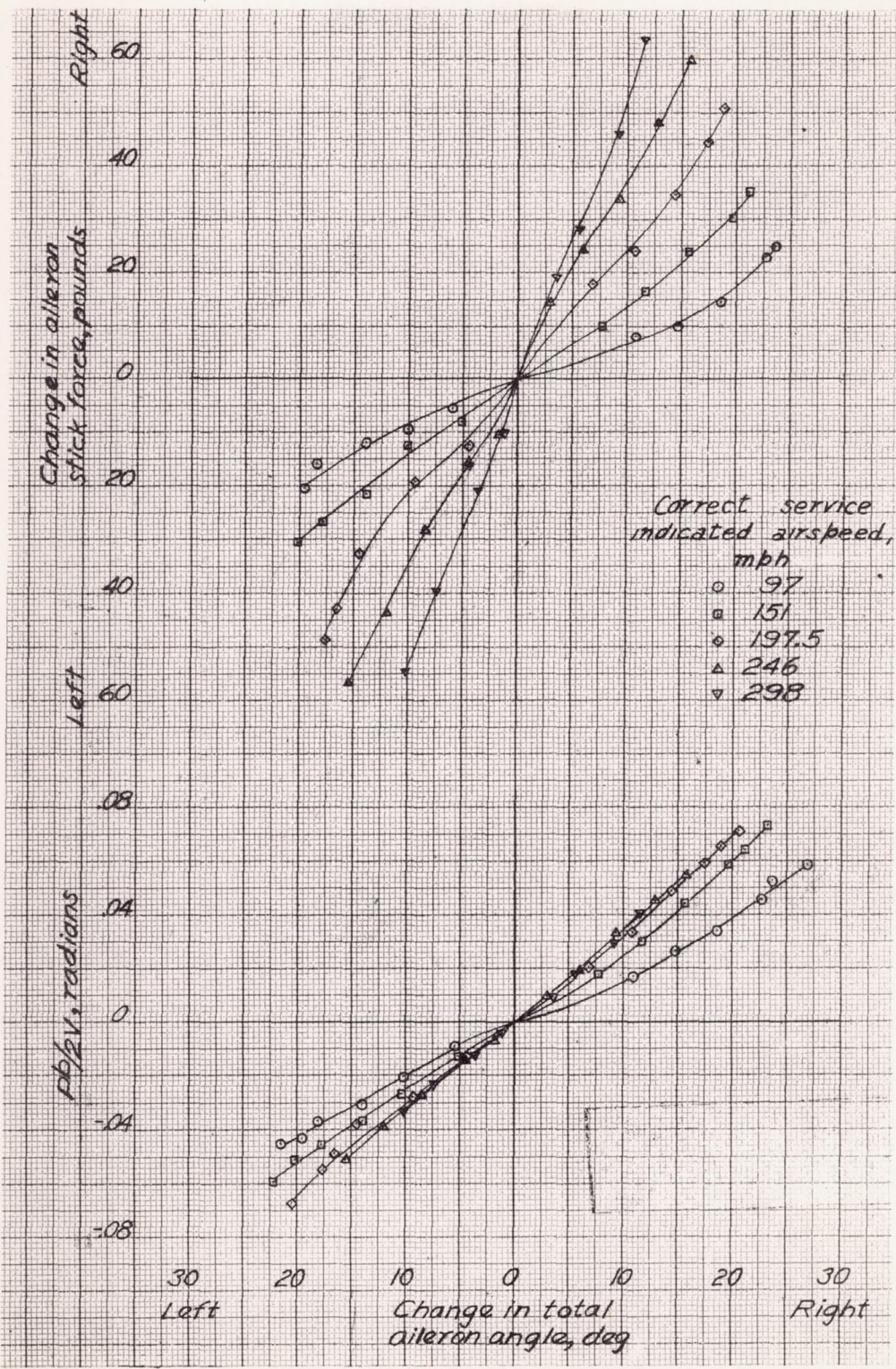

Figure 39.- Variation of aileron stick force and helix angle, $pb/2V$, with change in total aileron angle in rolls made at various speeds; flaps up, landing gear up, power for level flight, aileron gap unsealed, Curtiss SB2C-1 airplane.

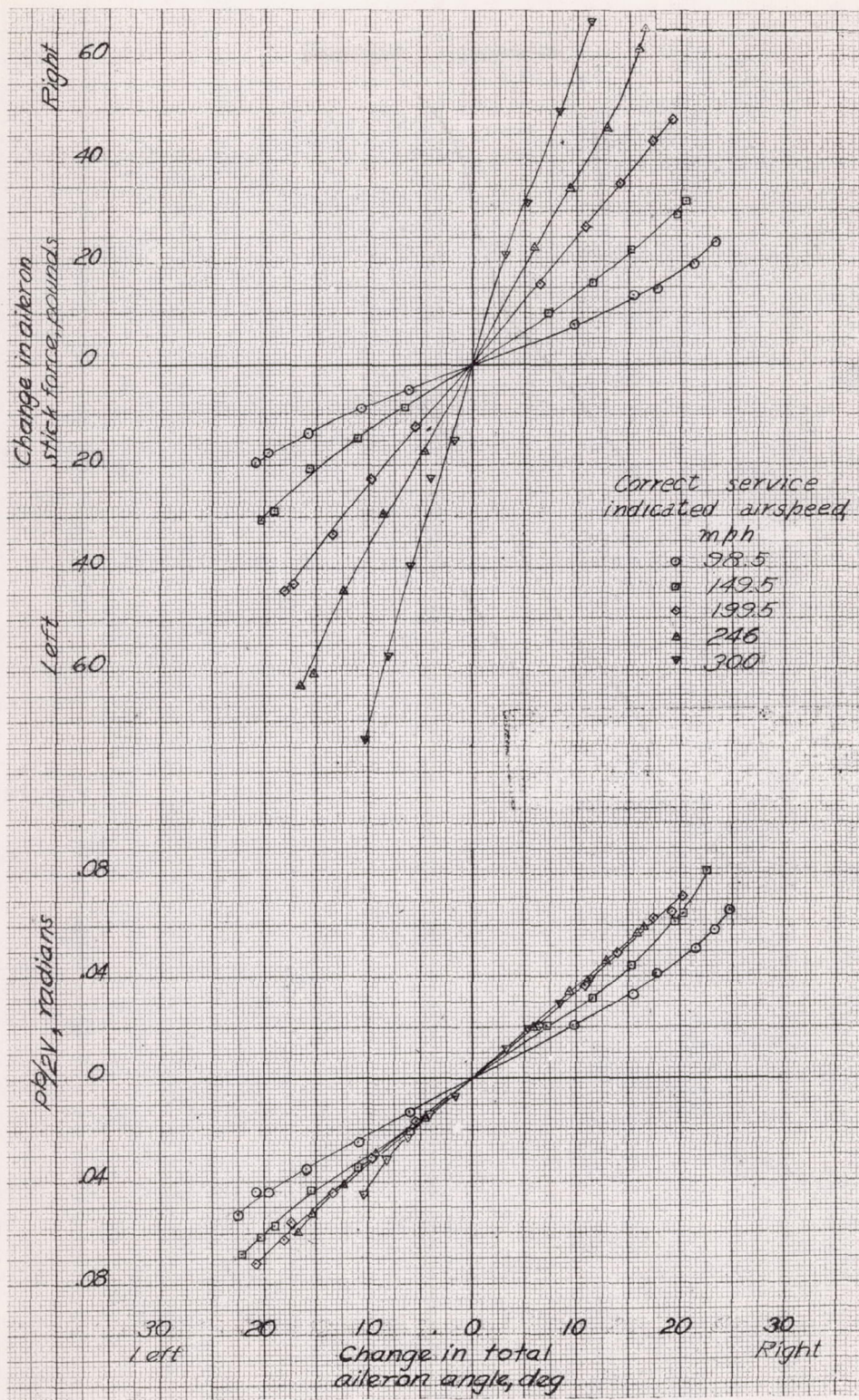

Figure 40.- Variation of aileron stick force and helix angle, $pb/2V$, with change in total aileron angle in rolls made at various speeds; flaps up, landing gear up, power for level flight, aileron gap sealed, Curtiss SB2C-1 airplane.

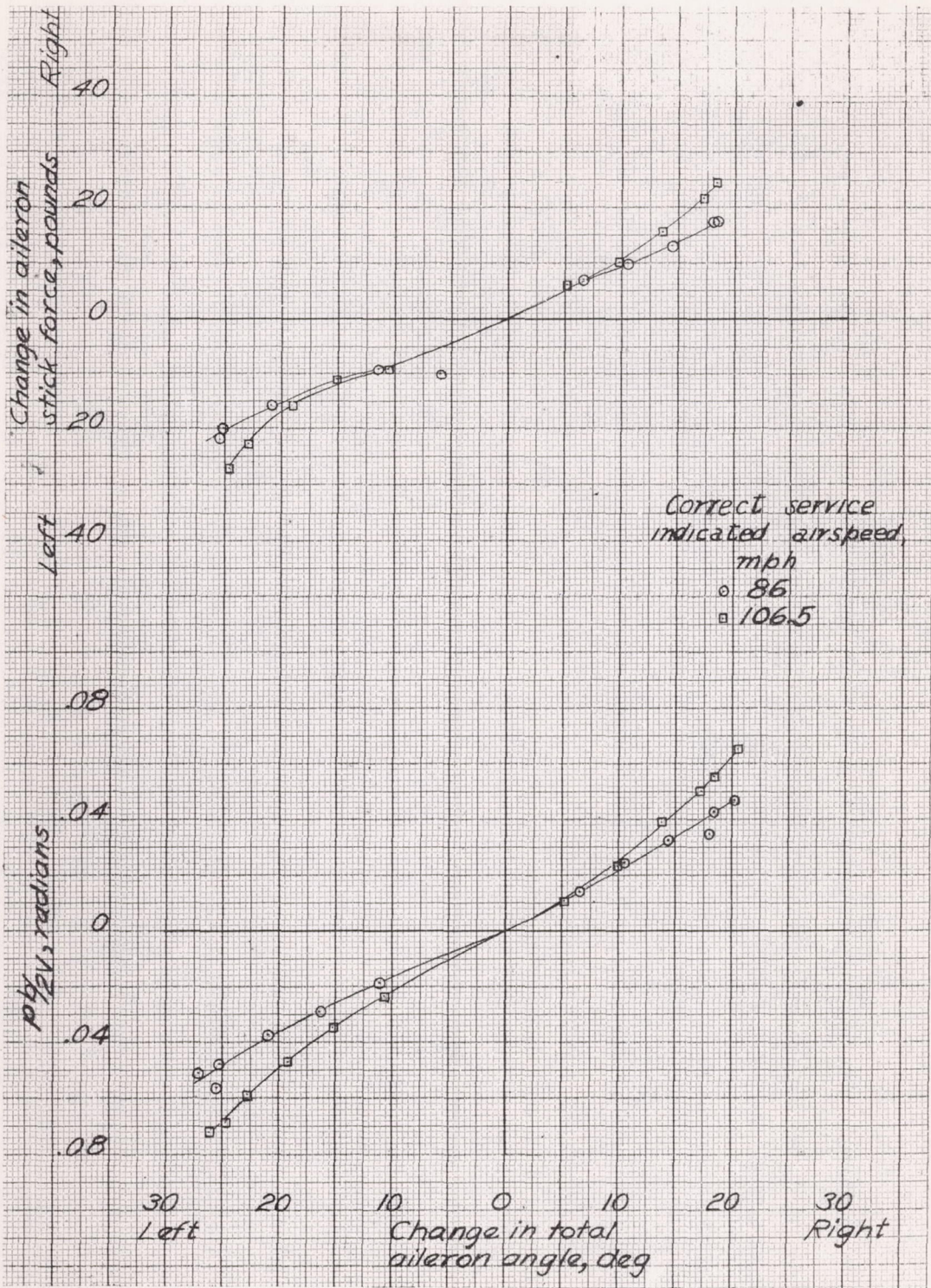

Figure 41.- Variation of aileron stick force and helix angle, $pb/2V$, with change in total aileron angle in rolls made at two speeds; flaps down, landing gear down, leading-edge slots open, power off, aileron gap unsealed, Curtiss SB2C-1 airplane.

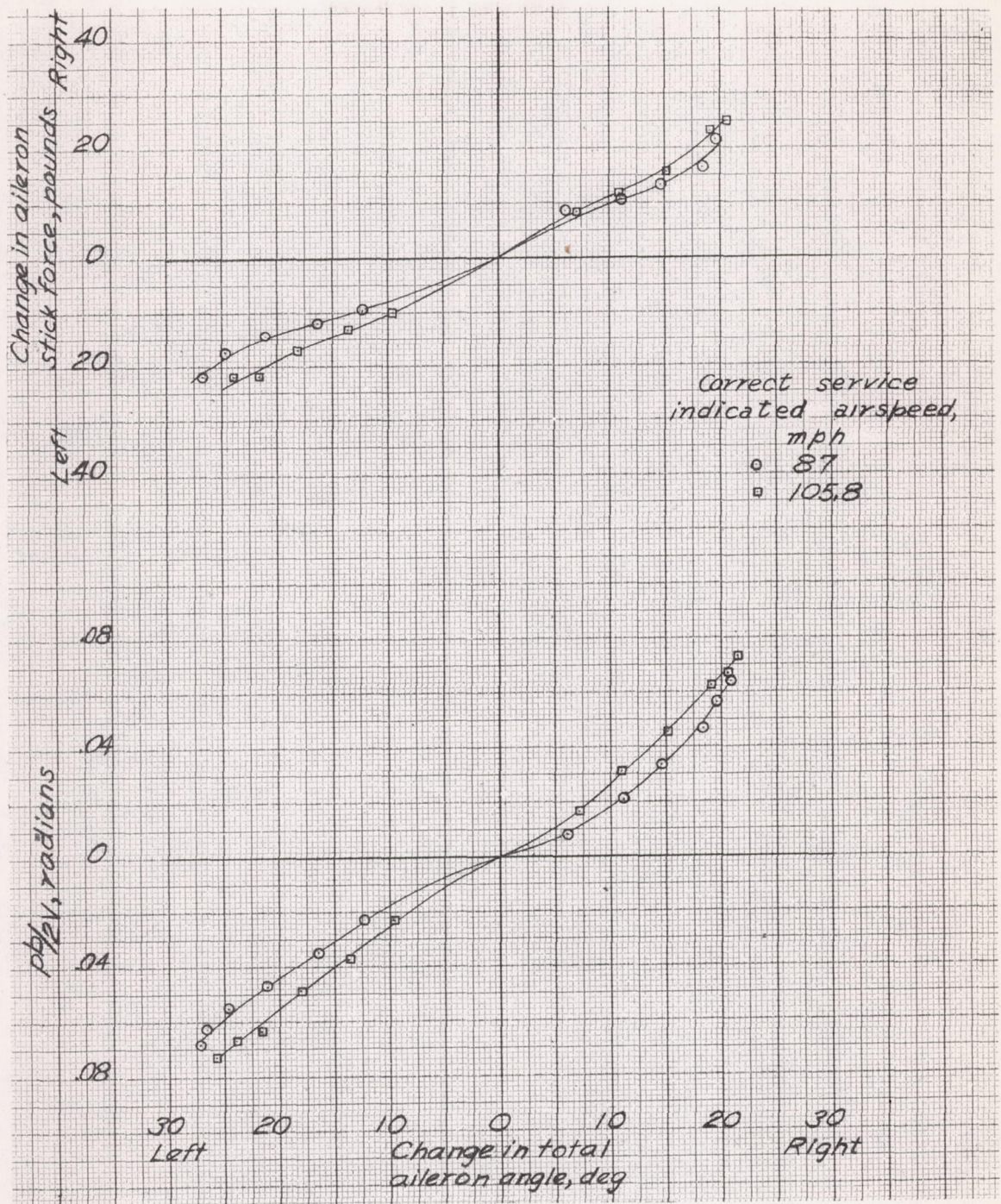

Figure 42.- Variation of aileron stick force and helix angle, $pb/2V$, with change in total aileron angle in rolls made at two speeds; flaps down, landing gear down, leading-edge slots open, power off, aileron gap sealed, Curtiss SB2C-1 airplane.

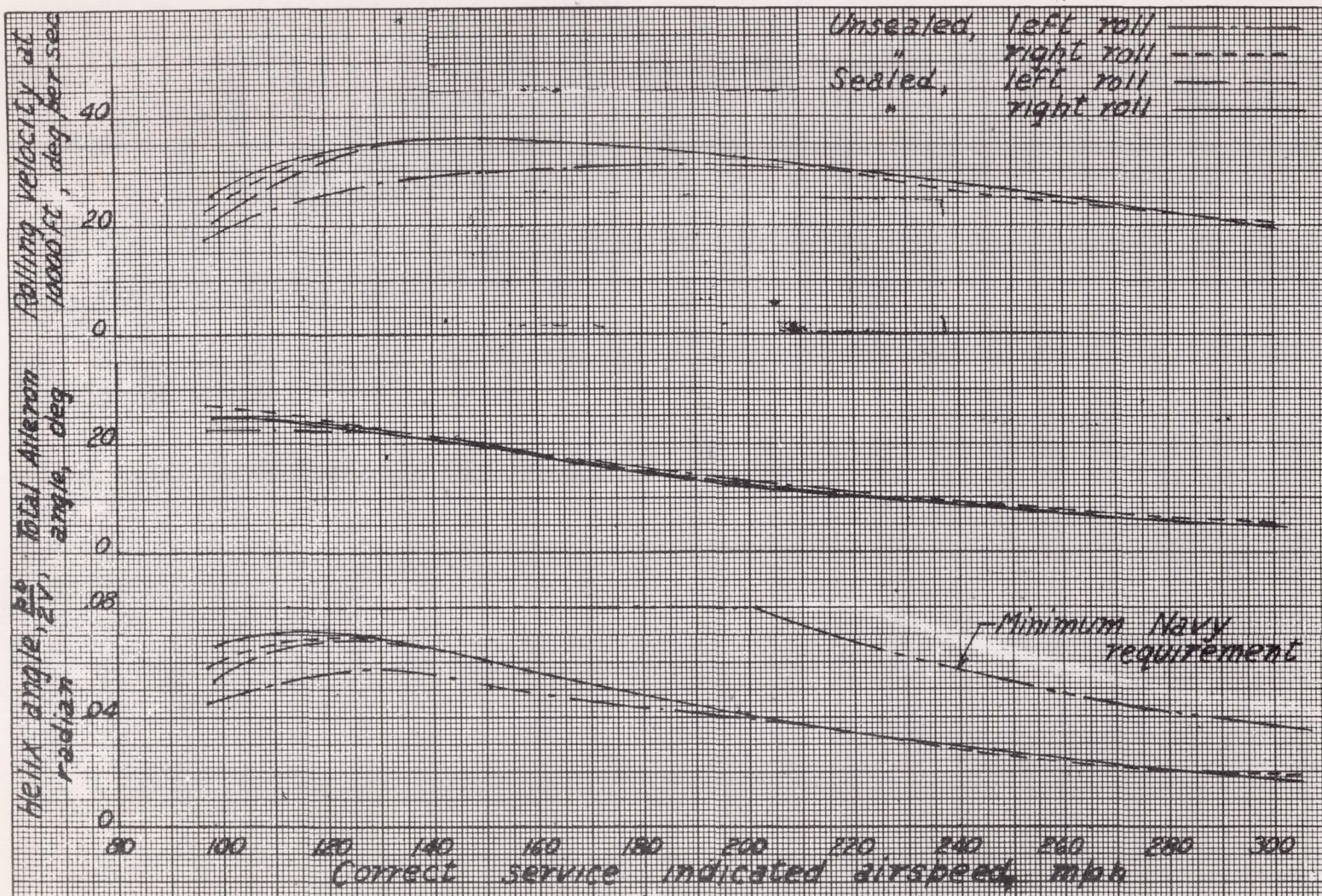

Figure 43.- Variation of helix angle, $\frac{pb}{2V}$, total aileron angle, and rolling velocity at 10,000 feet altitude obtainable with 30 pounds stick force as a function of speed. Flaps up, landing gear up, power for level flight, Curtiss SB2C-1 airplane.

L-571

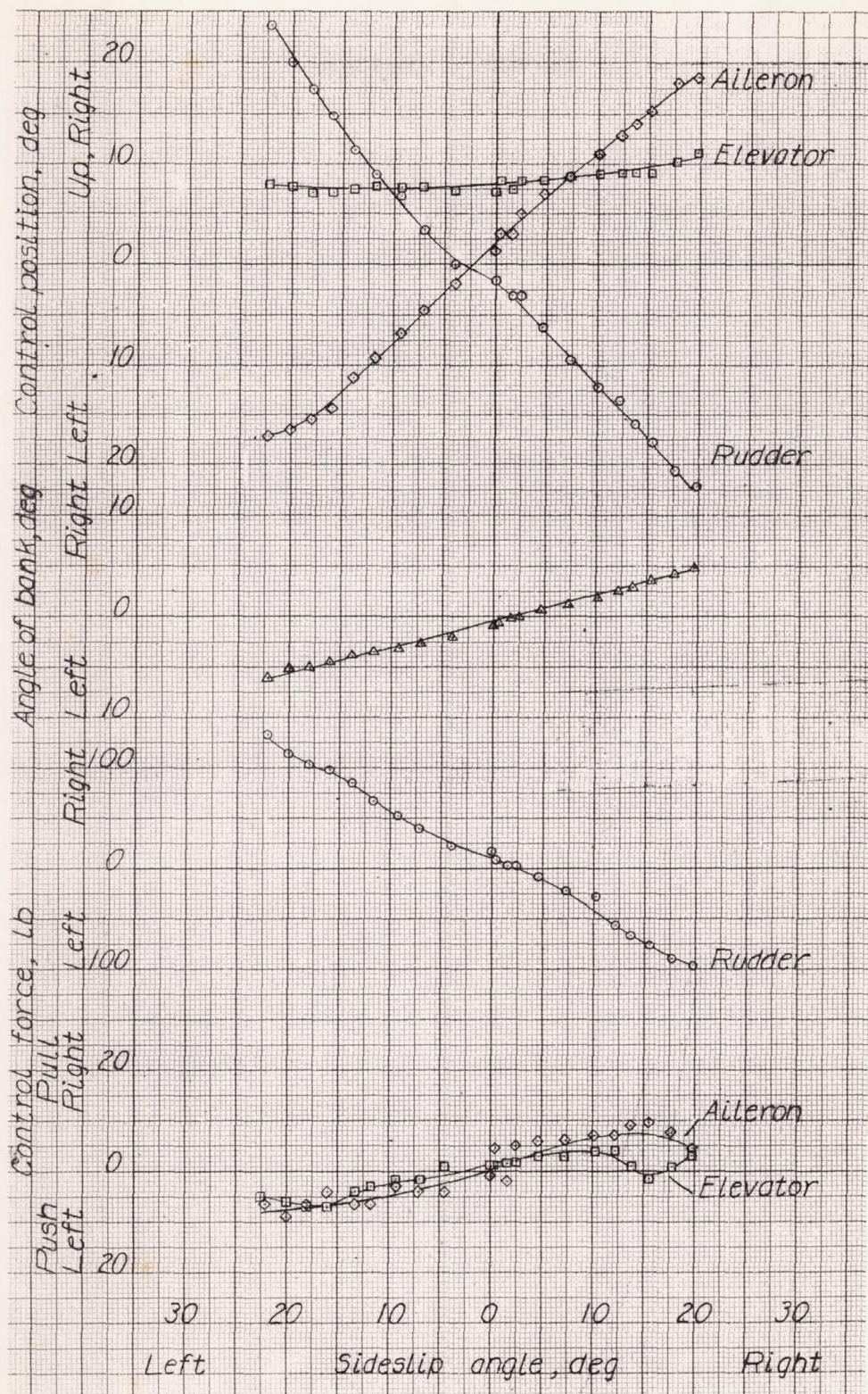

Figure 44.- Steady sideslip characteristics in the gliding condition (flaps up, landing gear up, power off) at 95 miles per hour. Curtiss SB2C-1 airplane.

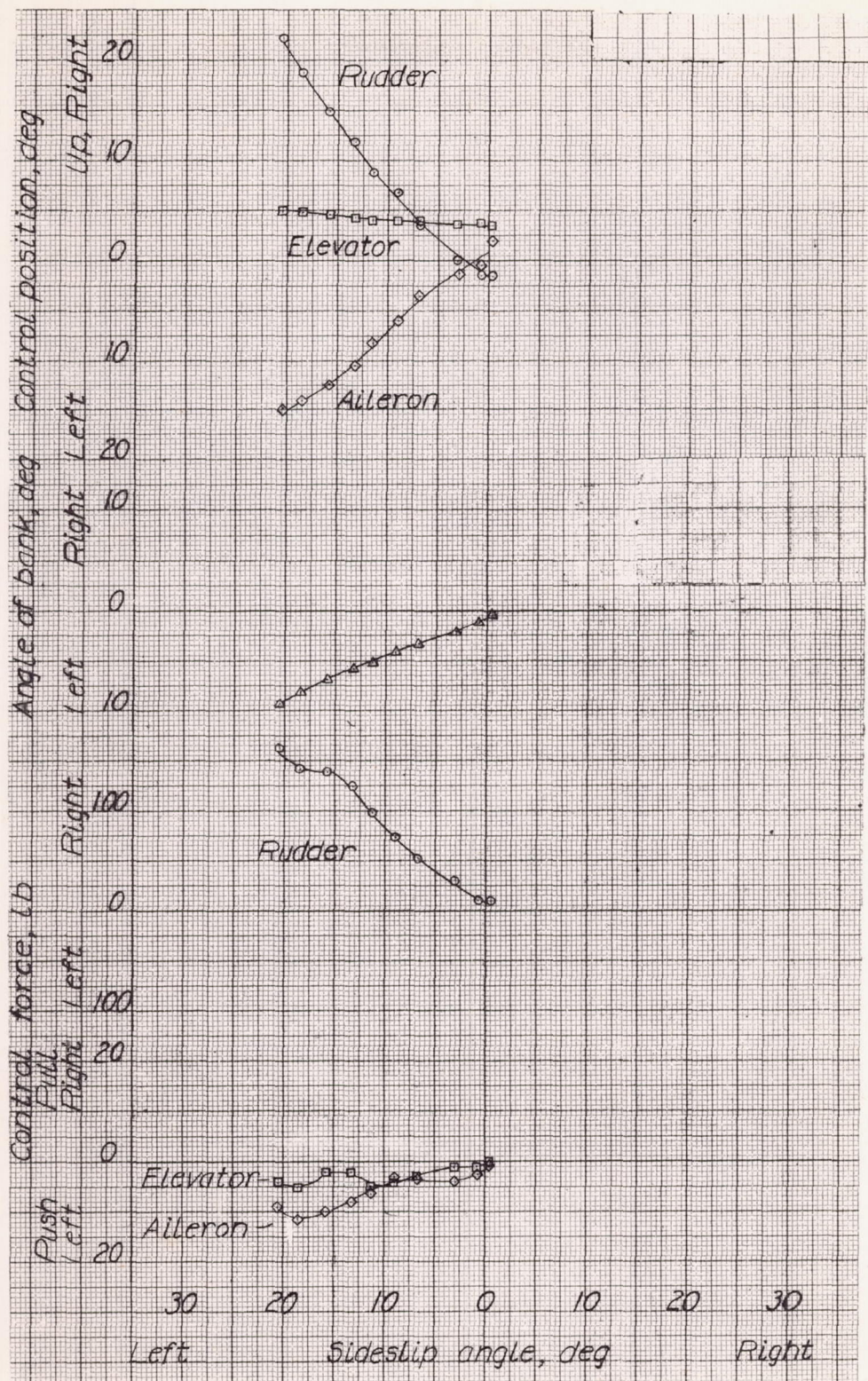

Figure 45.- Steady sideslip characteristics in the gliding condition (flaps up, landing gear up, power off) at 120 miles per hour. Curtiss SB2C-1 airplane.

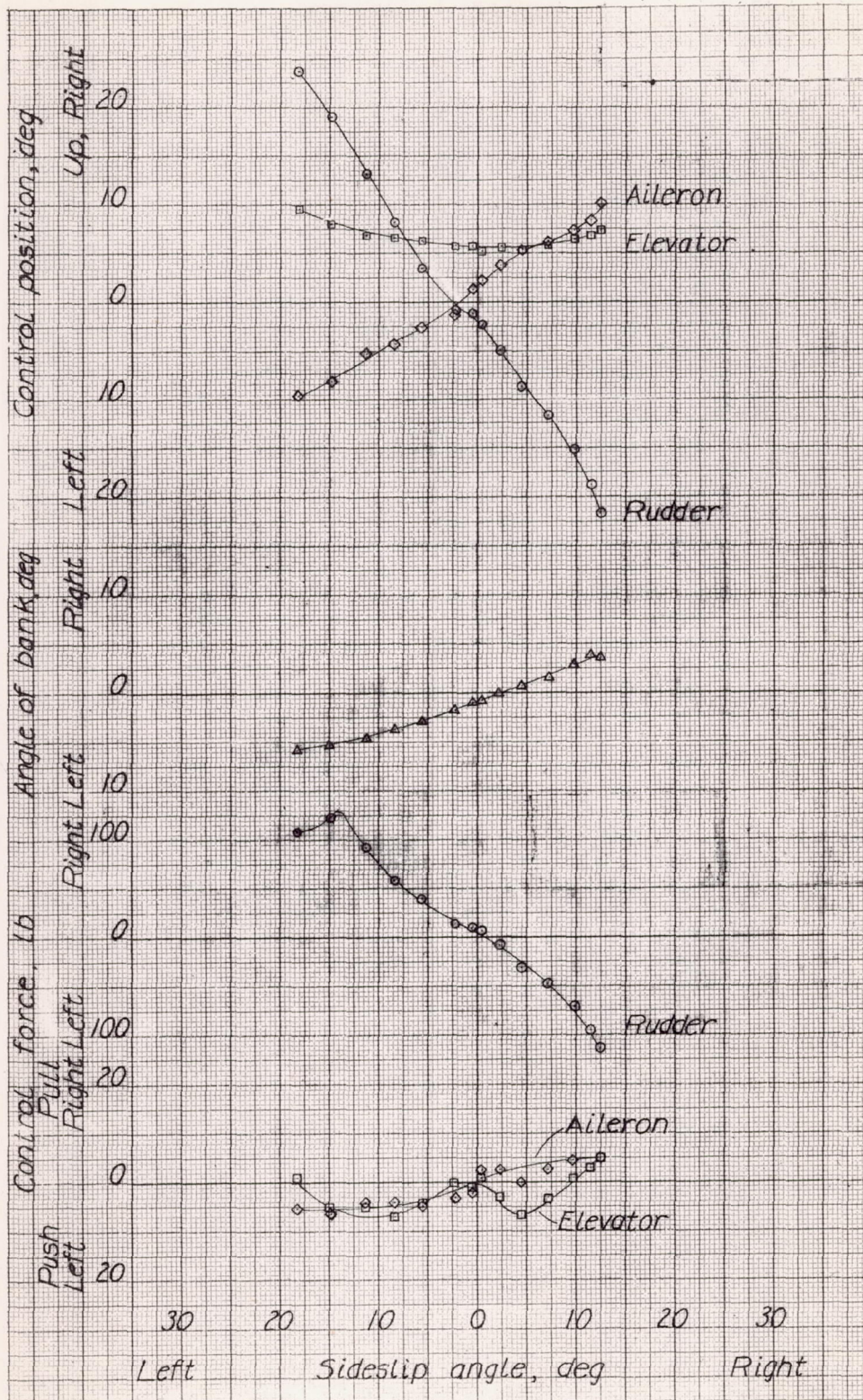

Figure 46.- Steady sideslip characteristics in the landing condition (flaps down, landing gear down, power off) at 95 miles per hour. Curtiss SB2C-1 airplane.

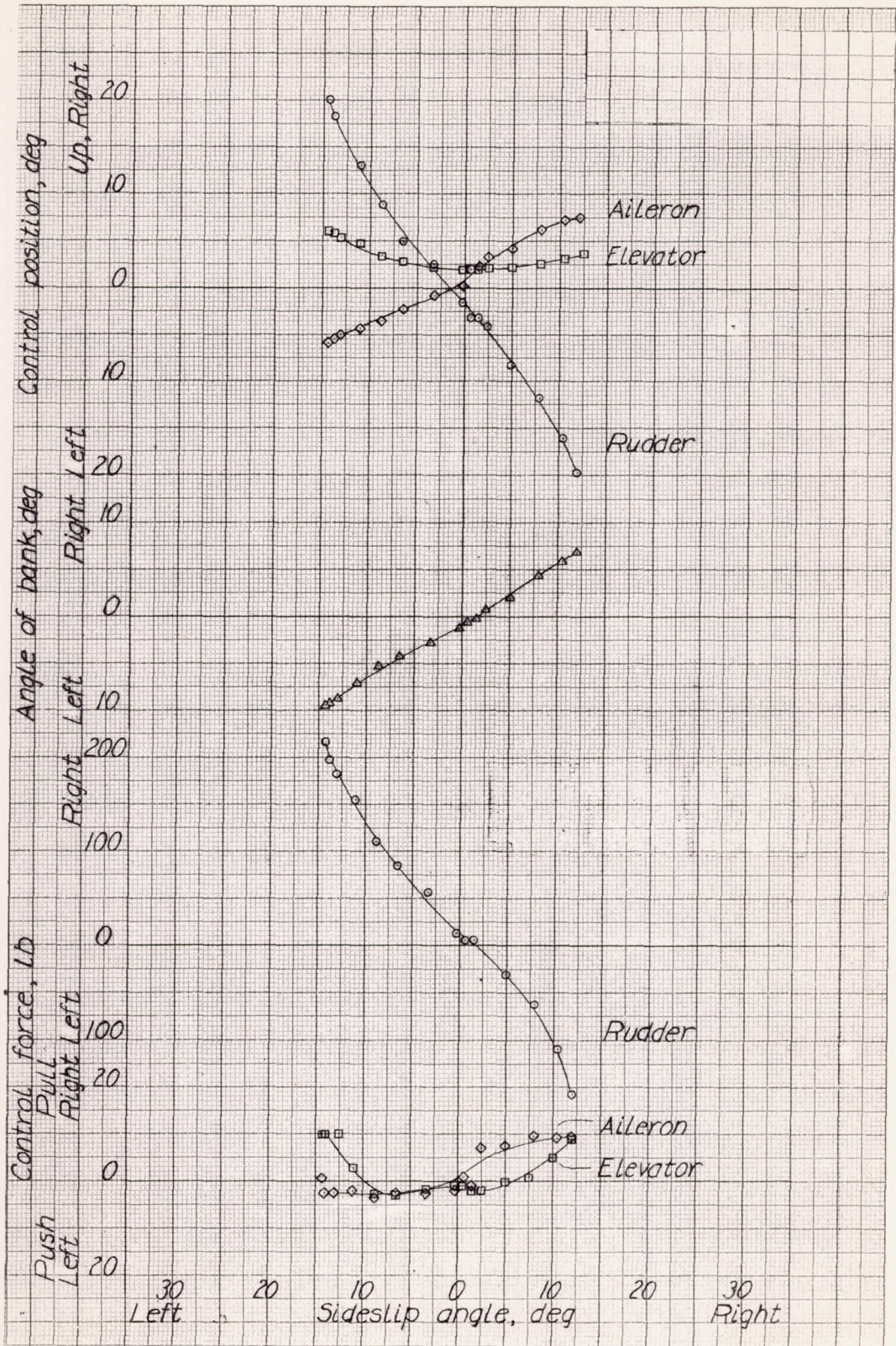

Figure 47.- Steady sideslip characteristics in the landing condition (flaps down, landing gear down, power off) at 120 miles per hour. Curtiss SB2C-1 airplane.

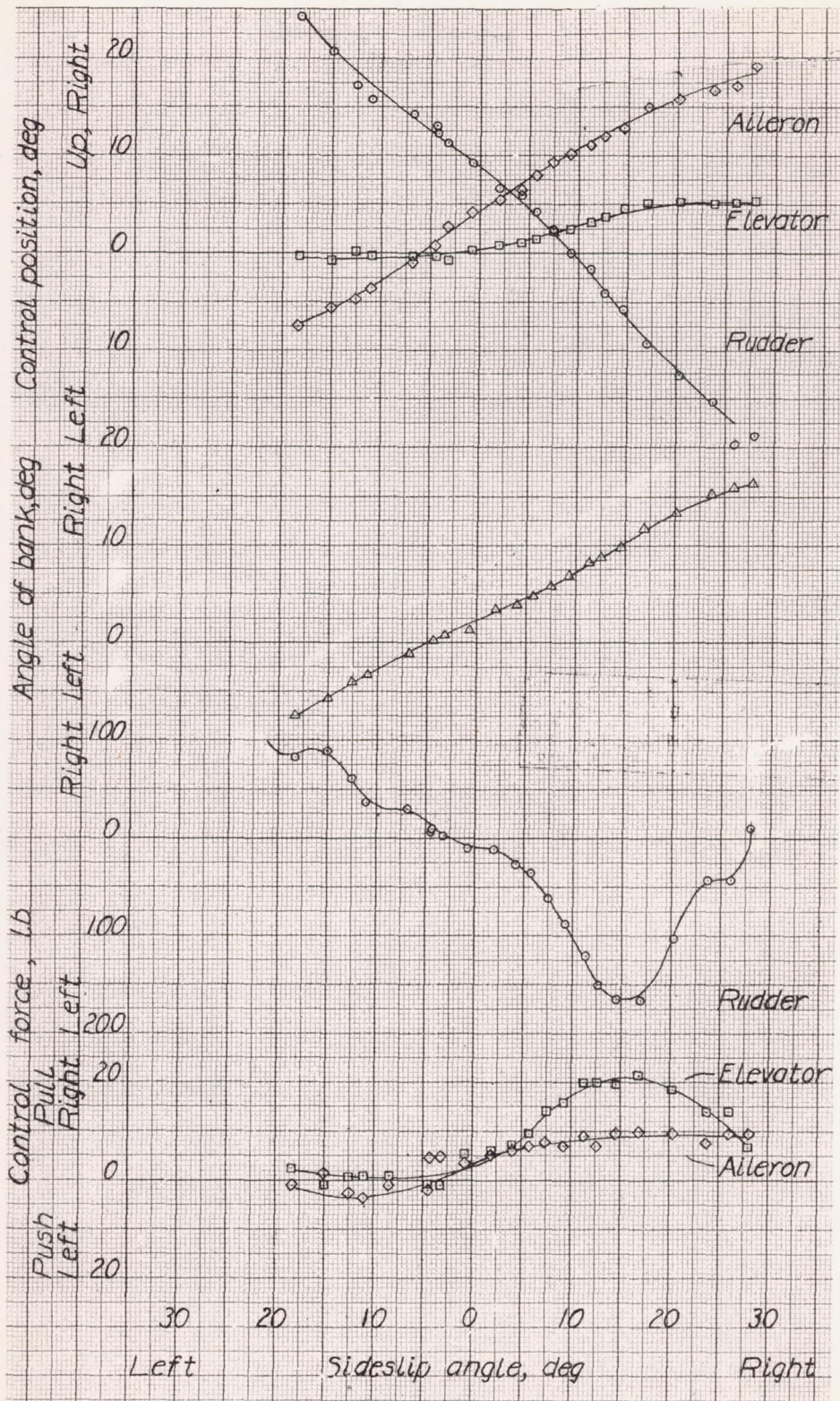

Figure 48.- Steady sideslip characteristics in the climbing condition (flaps up, landing gear up, 38 inches of Hg at 2400 rpm) at 95 miles per hour. Curtiss SB2C-1 airplane.

L-571

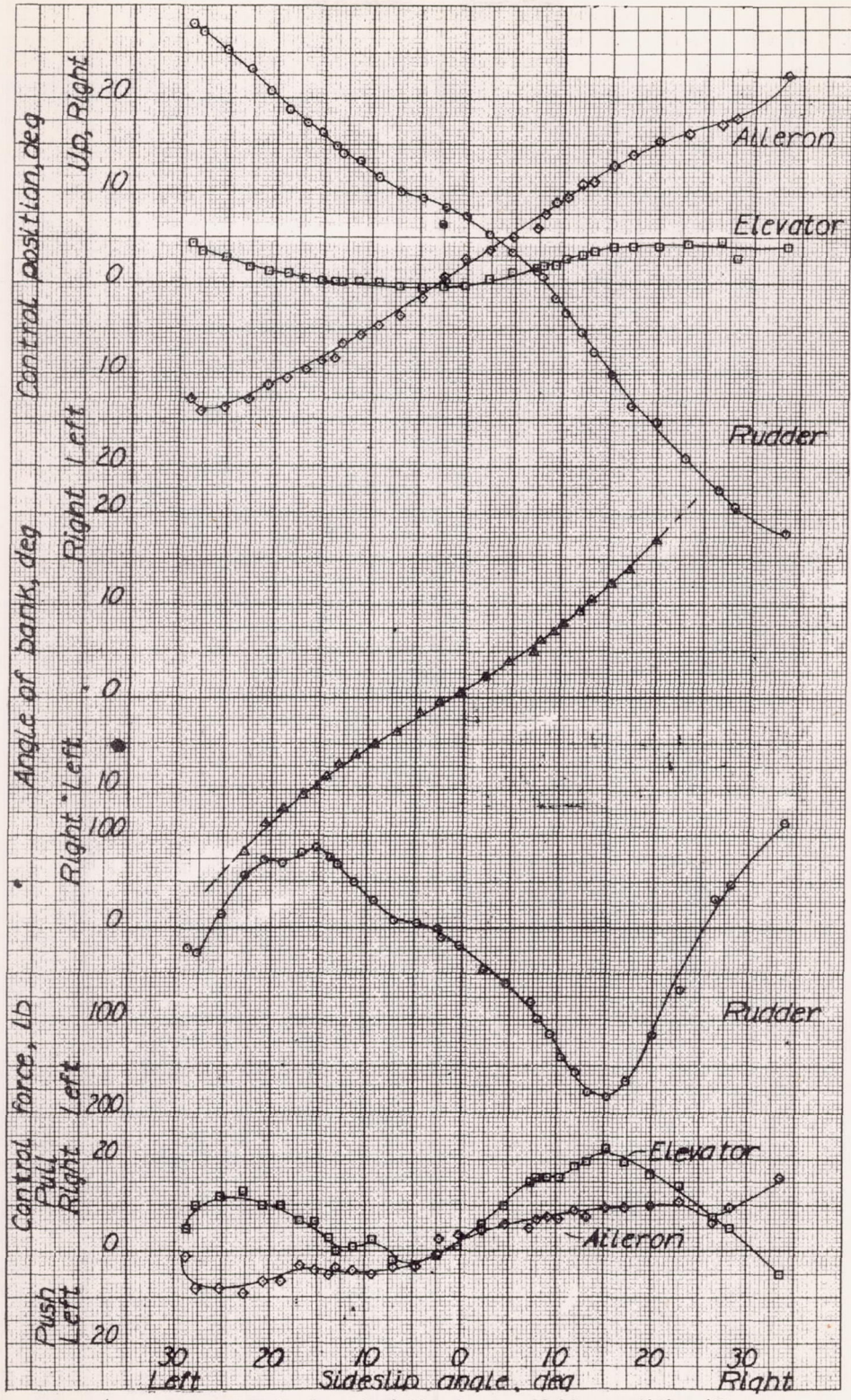

Figure 49.- Steady sideslip characteristics in the climbing condition (flaps up, landing gear up, 38 inches of Hg at 2400 rpm) at 120 miles per hour. Curtiss SB2C-1 airplane.

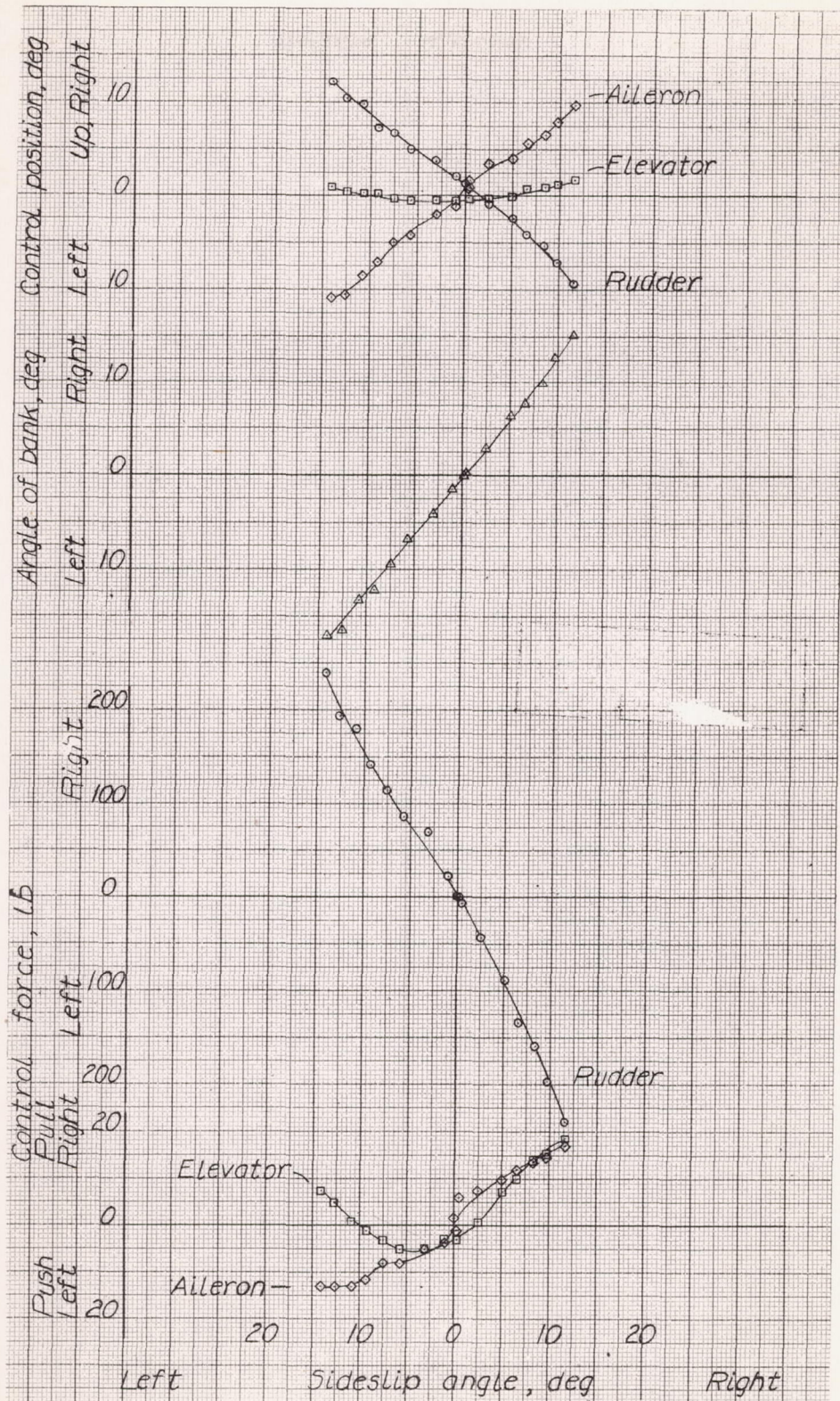

Figure 50.- Steady sideslip characteristics in the climbing condition (flaps up, landing gear up, 38 inches of Hg at 2400 rpm) at 180 miles per hour. Curtiss SB2C-1 airplane.

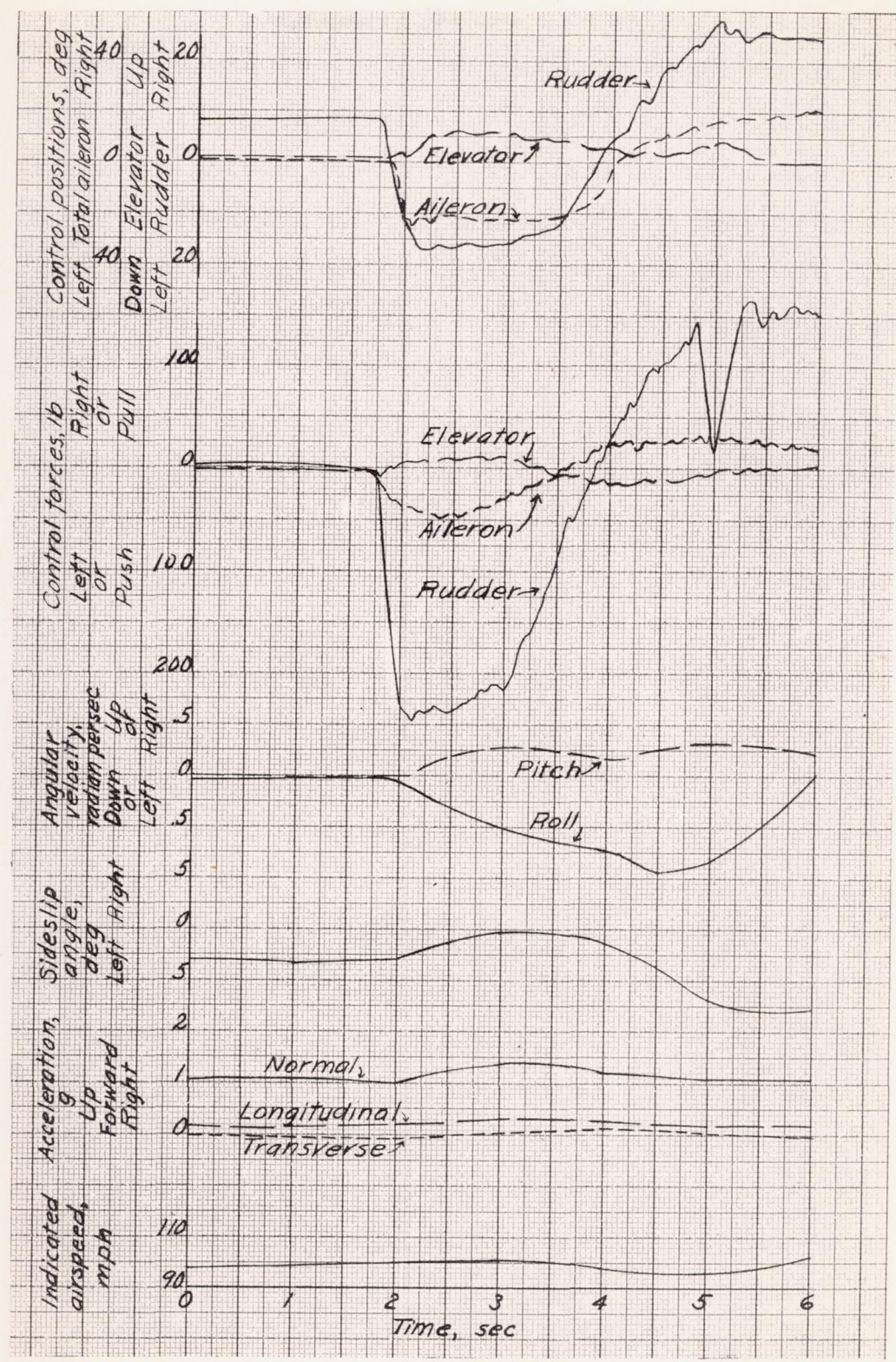

Figure 51.- Time history of a roll into a turn in which the rudder was used in an attempt to maintain zero sideslip. Curtiss SB2C-1 airplane, flaps up, landing gear up, power for level flight.

L-571

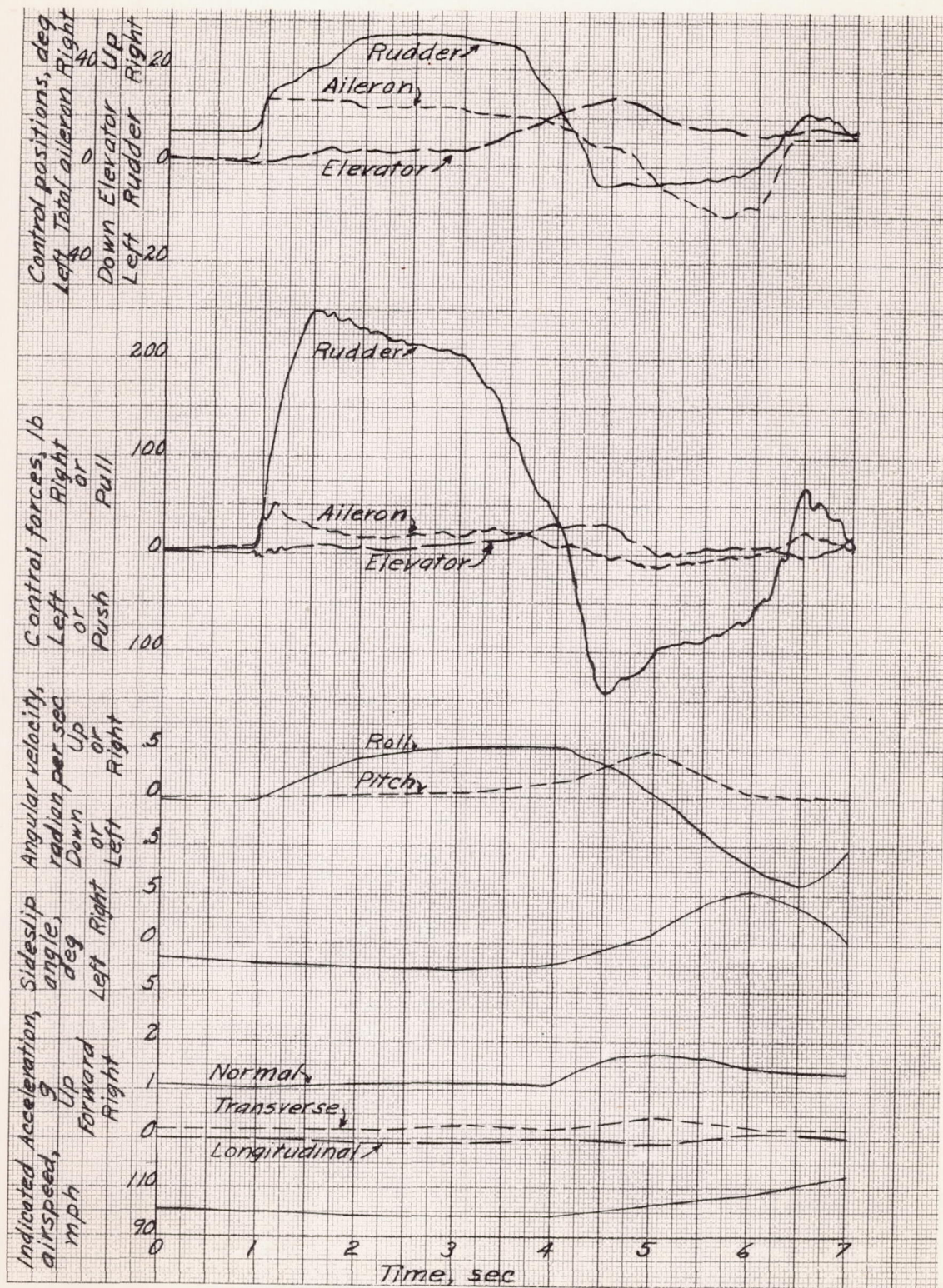

Figure 52.- Time history of a roll into a turn in which the rudder was used in an attempt to maintain zero sideslip, Curtiss SB2C-1 airplane, flaps up, landing gear up, power for level flight.

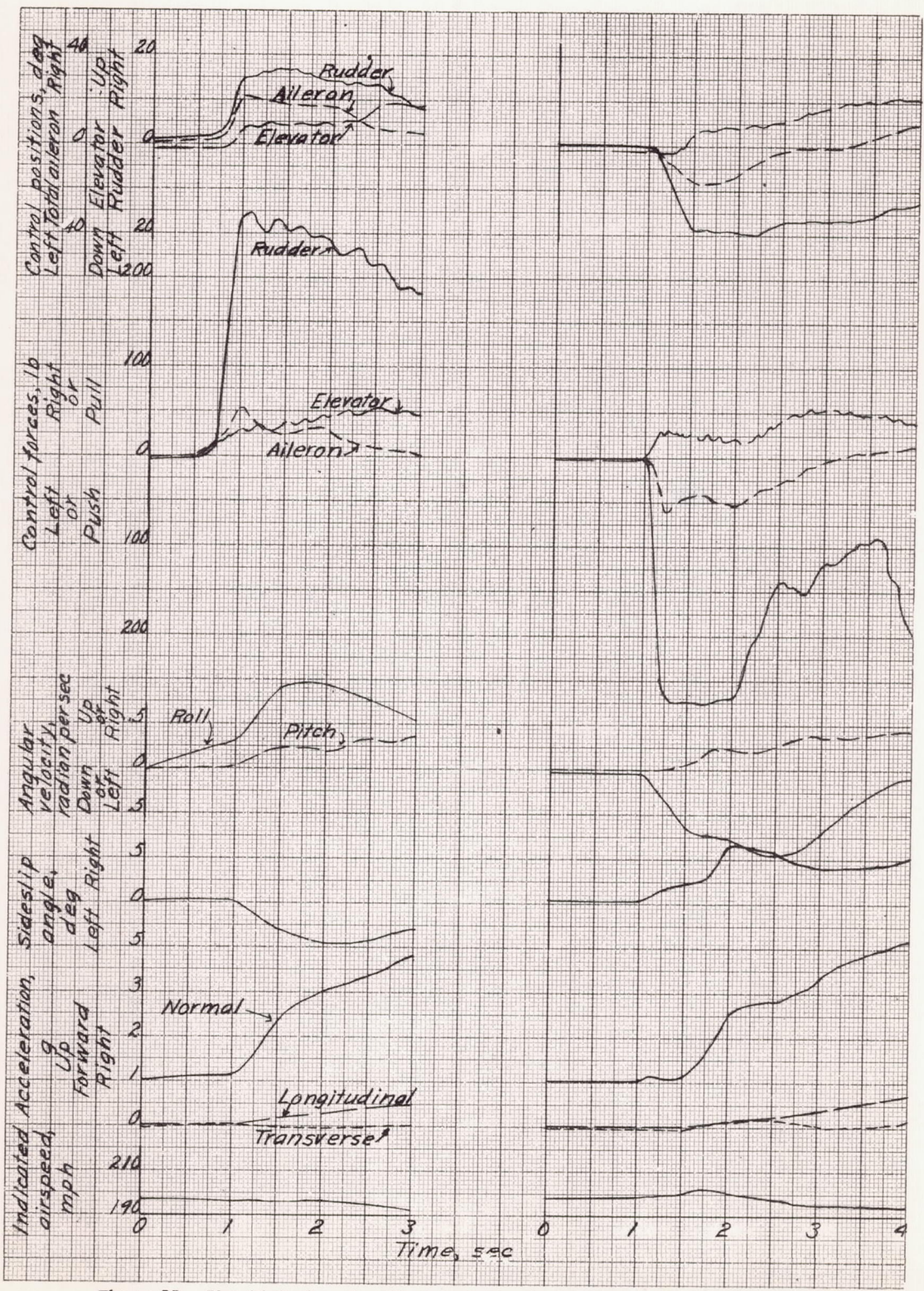

Figure 53.- Time histories of rolls into left and right turns in which the rudder was used in an attempt to maintain zero sideslip. Note that too much rudder deflection was used. Curtiss SB2C-1 airplane, flaps up, landing gear up, power for level flight.

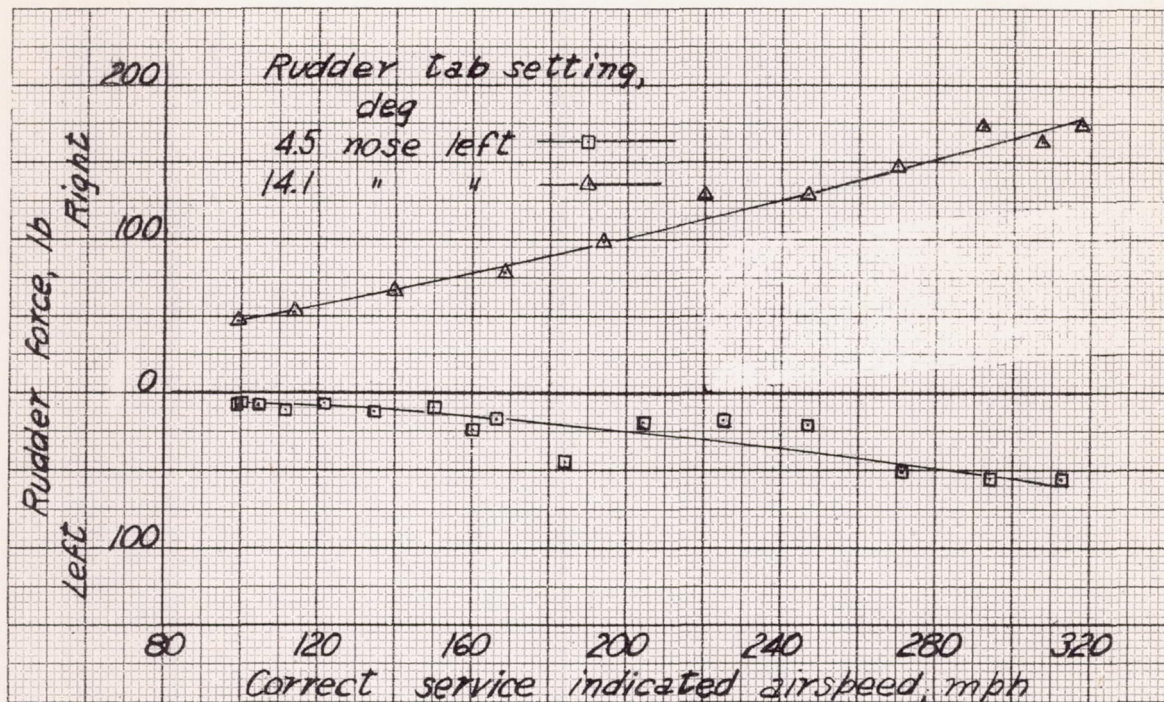

Figure 54.- Variation of rudder force with speed with two rudder trim tab settings; flaps up, landing gear up, front hood closed, rear hood open, power off. Curtiss SB2C-1 airplane.

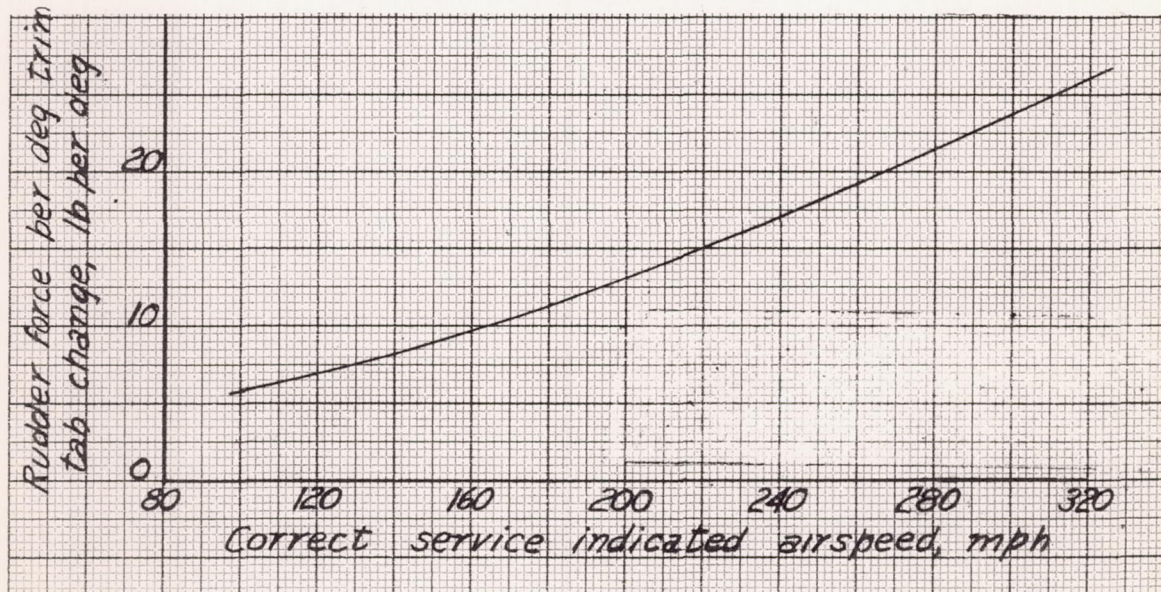

Figure 55.- Variation of power of rudder trim tab with speed. Curtiss SB2C-1 airplane.

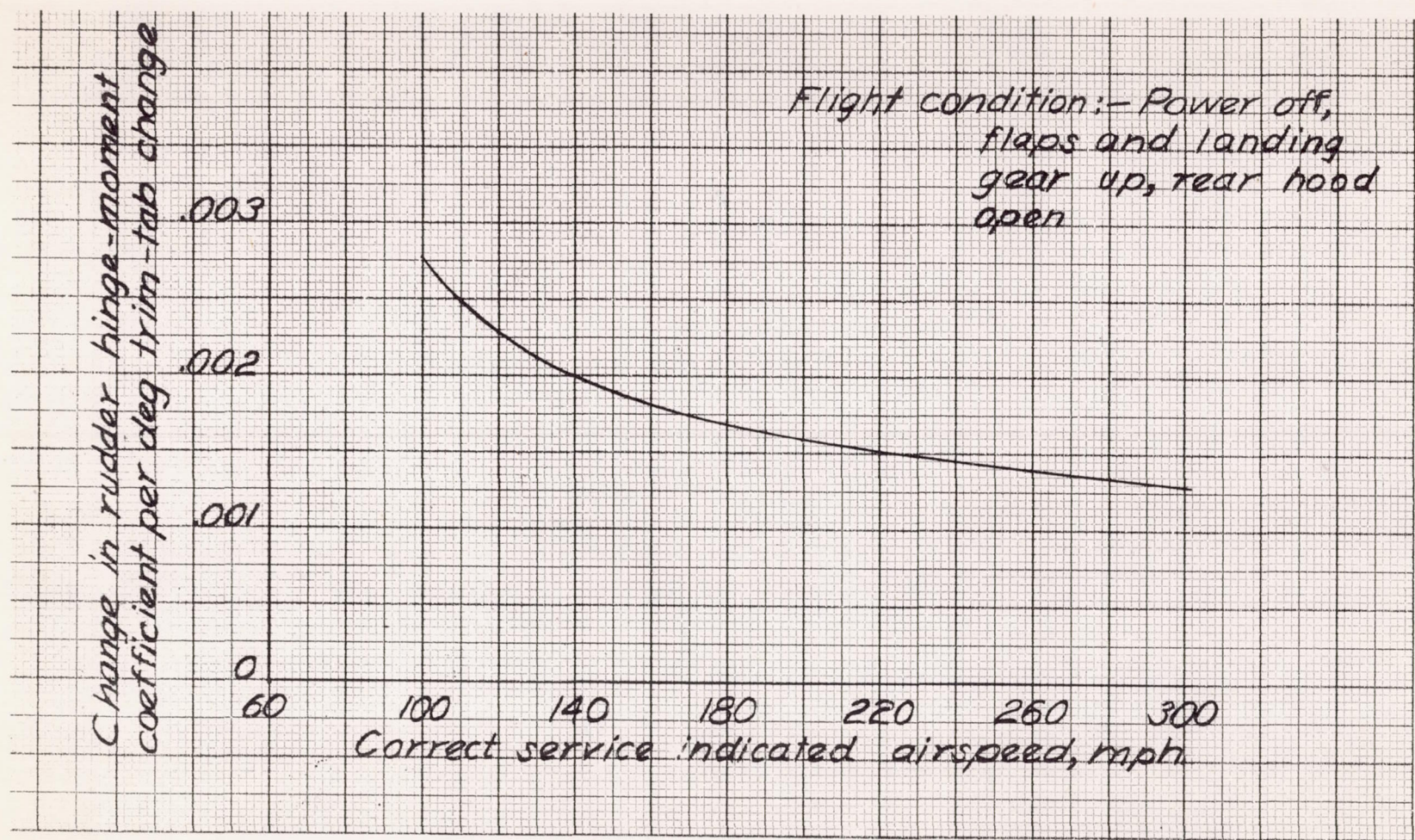

Figure 56.- Variation of changes in rudder hinge-moment coefficient per degree trim-tab deflection with indicated airspeed. Curtiss SB2C-1 airplane.

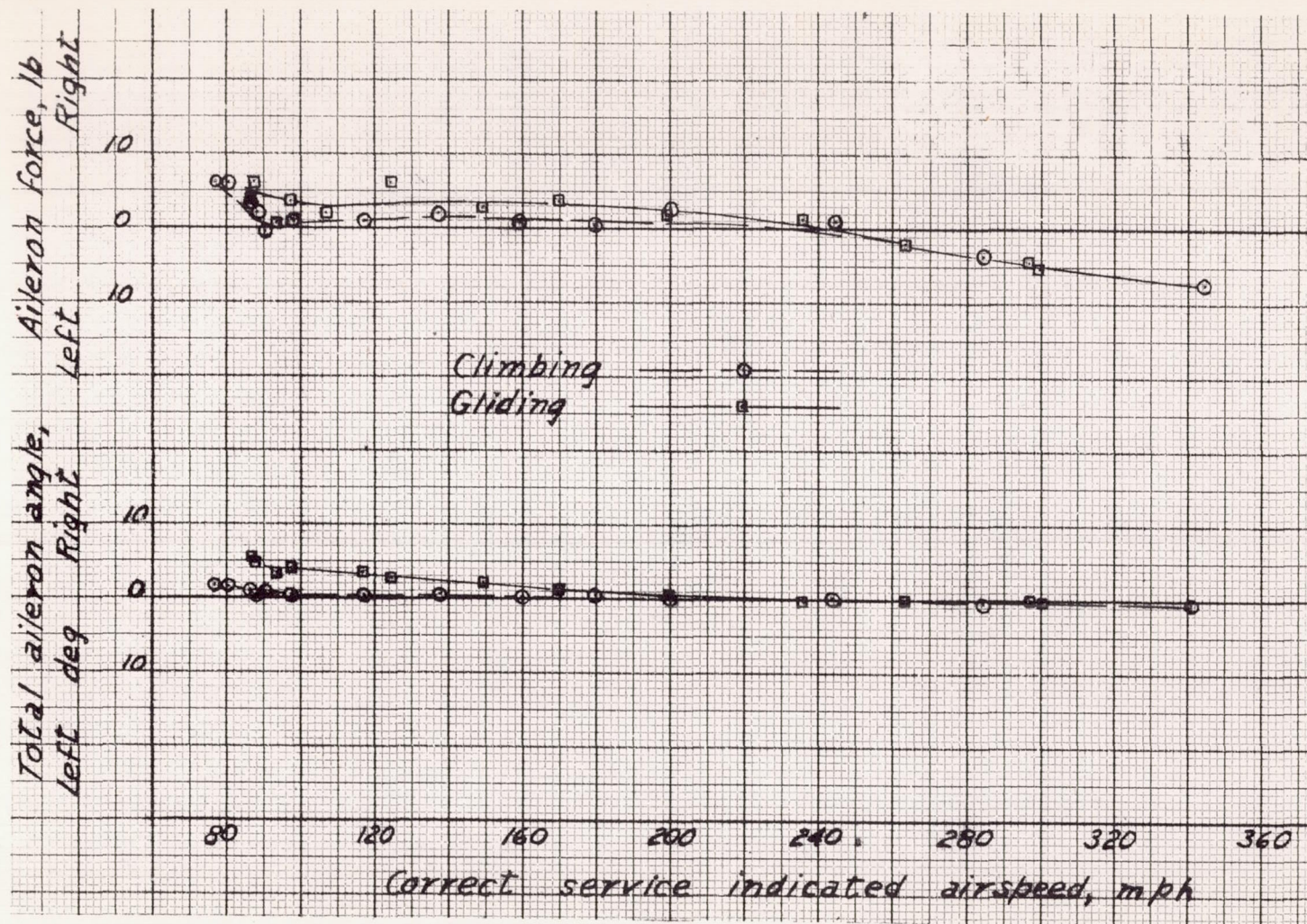

Figure 57.- Variation with speed of aileron angle and aileron force required for trim; aileron gap unsealed, Curtiss SB2C-1 airplane.

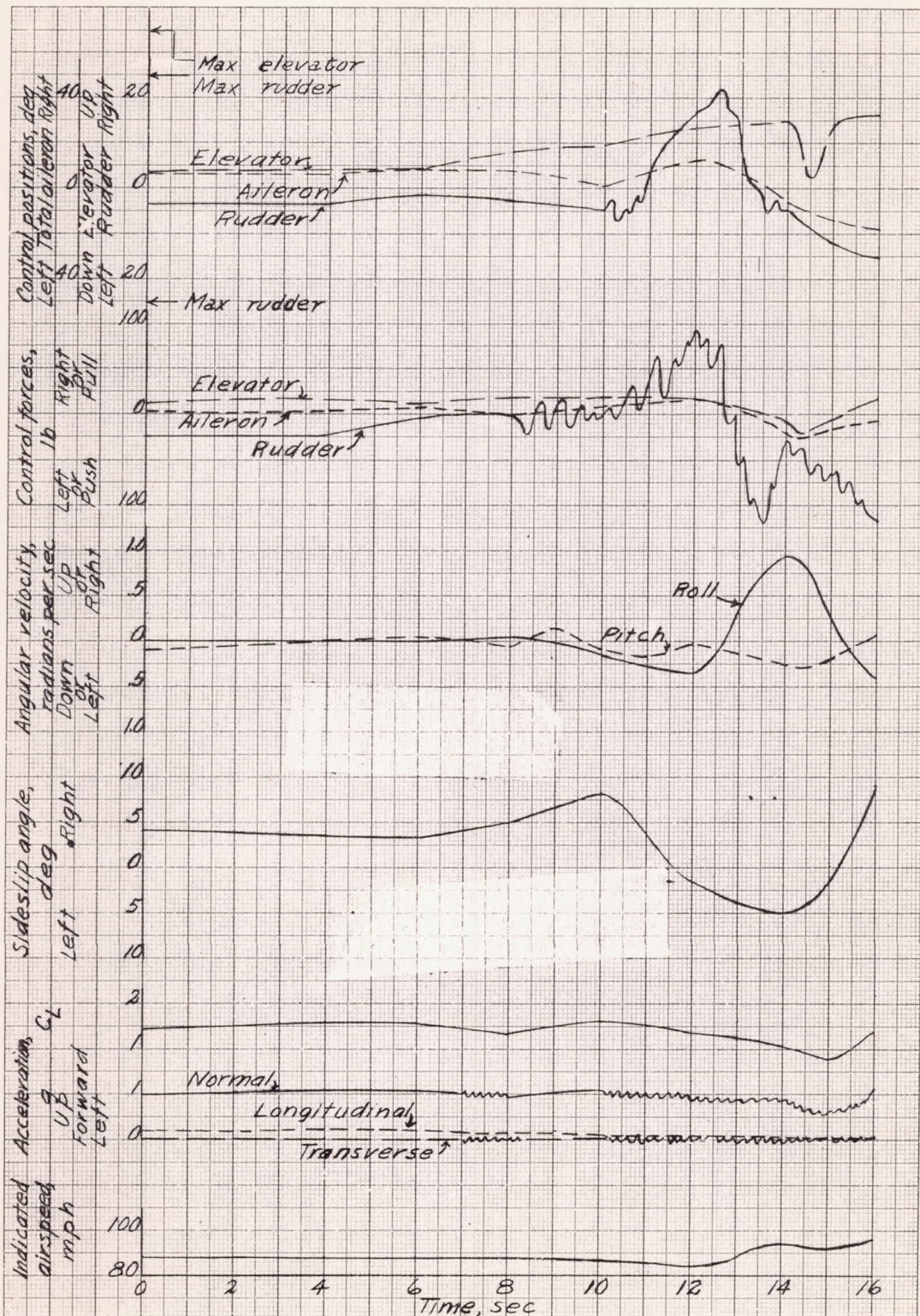

Figure 58.- Time history of a stall in the gliding condition (flaps up, landing gear up, hoods closed, cowl flaps closed, power off) center of gravity at 29.8 percent of the mean aerodynamic chord, bobweight installed, Curtiss SB2C-1 airplane.

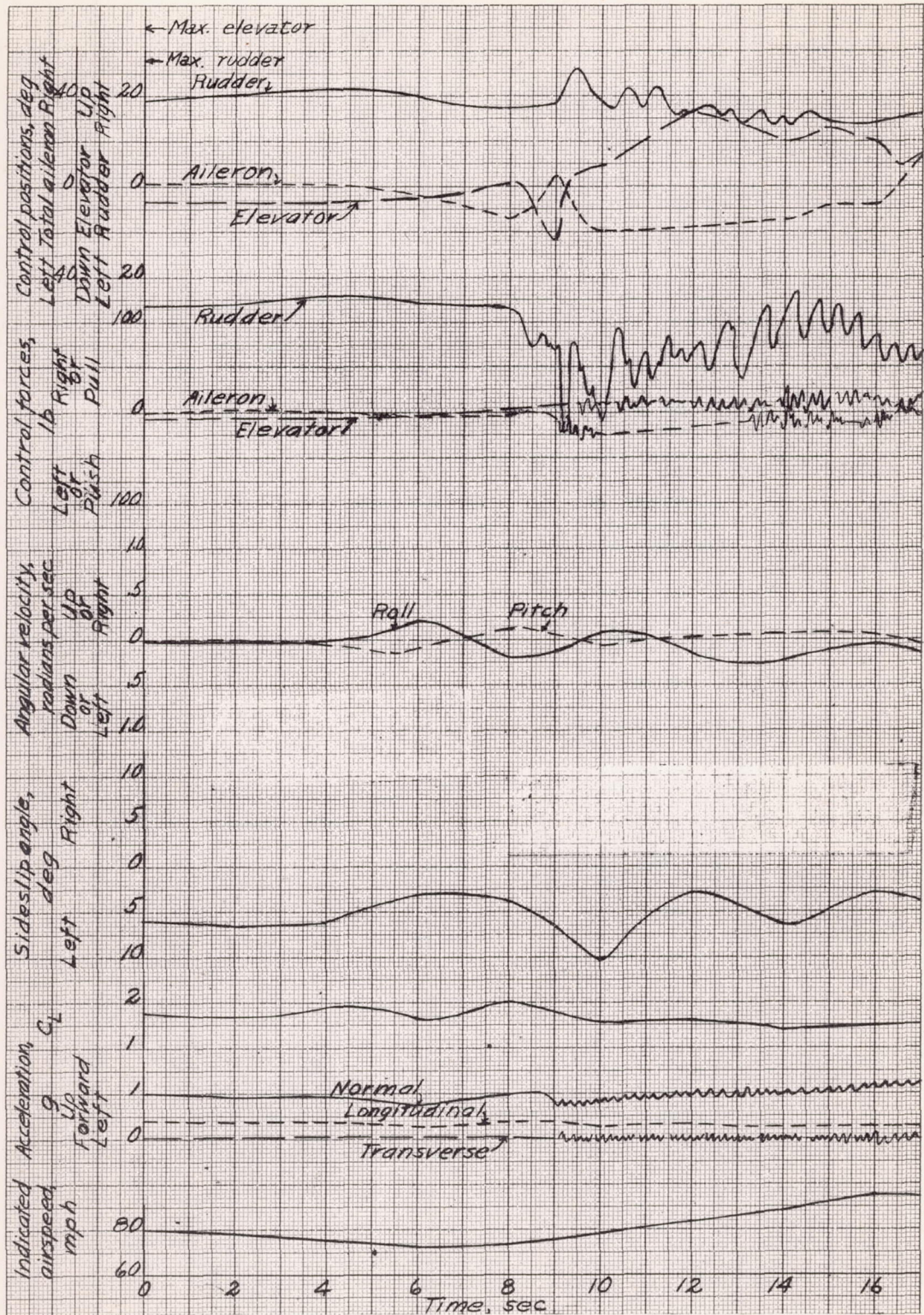

Figure 59.- Time history of a stall in the climbing condition (flaps up, landing gear up, hoods closed, cowl flaps open, rated power) center of gravity at 30.2 percent of the mean aerodynamic chord, bobweight installed, Curtiss SB2C-1 airplane.

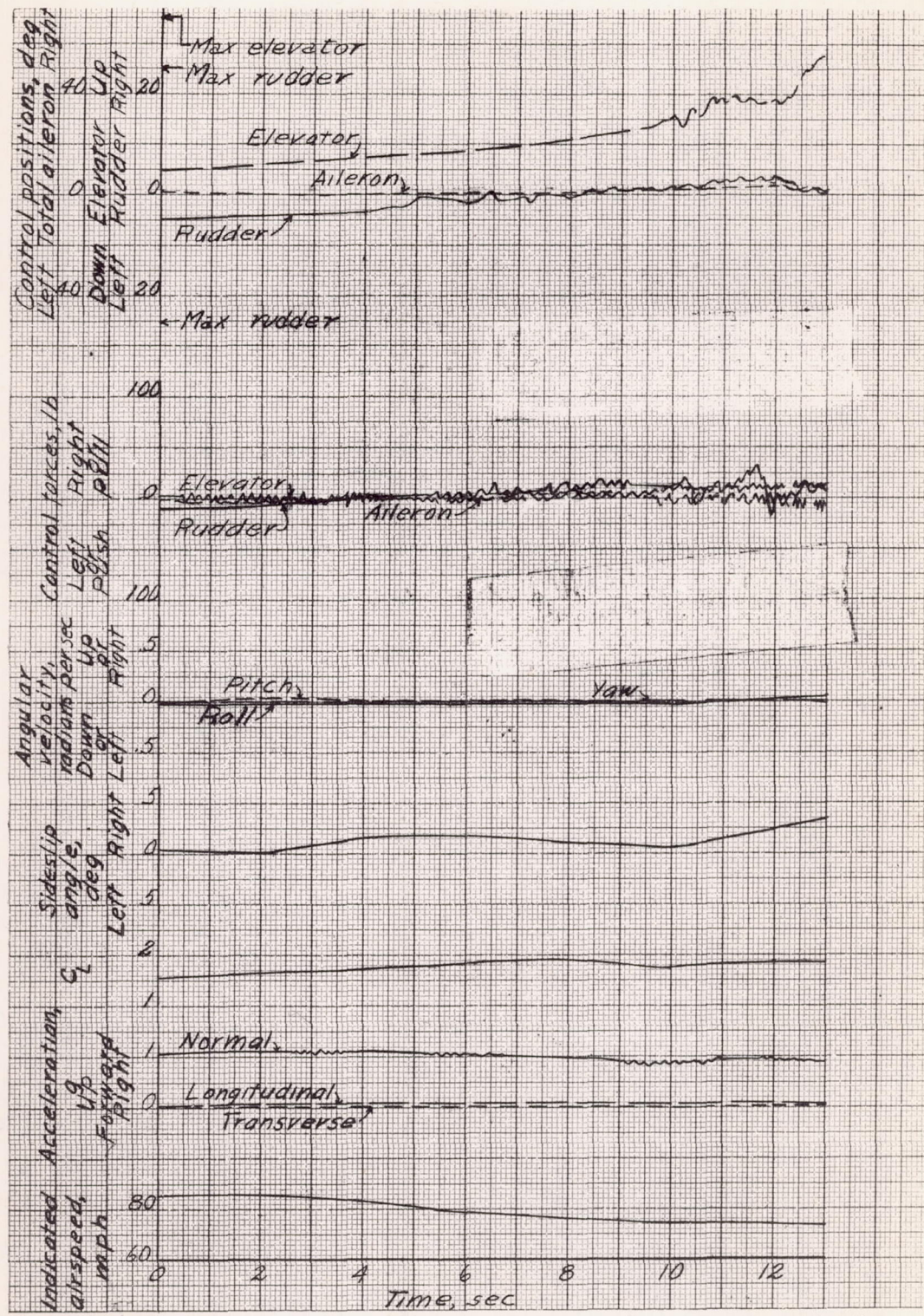

Figure 60.- Time history of a stall in the landing condition (flaps down, landing gear down, front hood open, rear hood closed, cowl flaps one-third open, power off) center of gravity at 26.8 percent of the mean aerodynamic chord. Curtiss SB2C-1 airplane.

1571

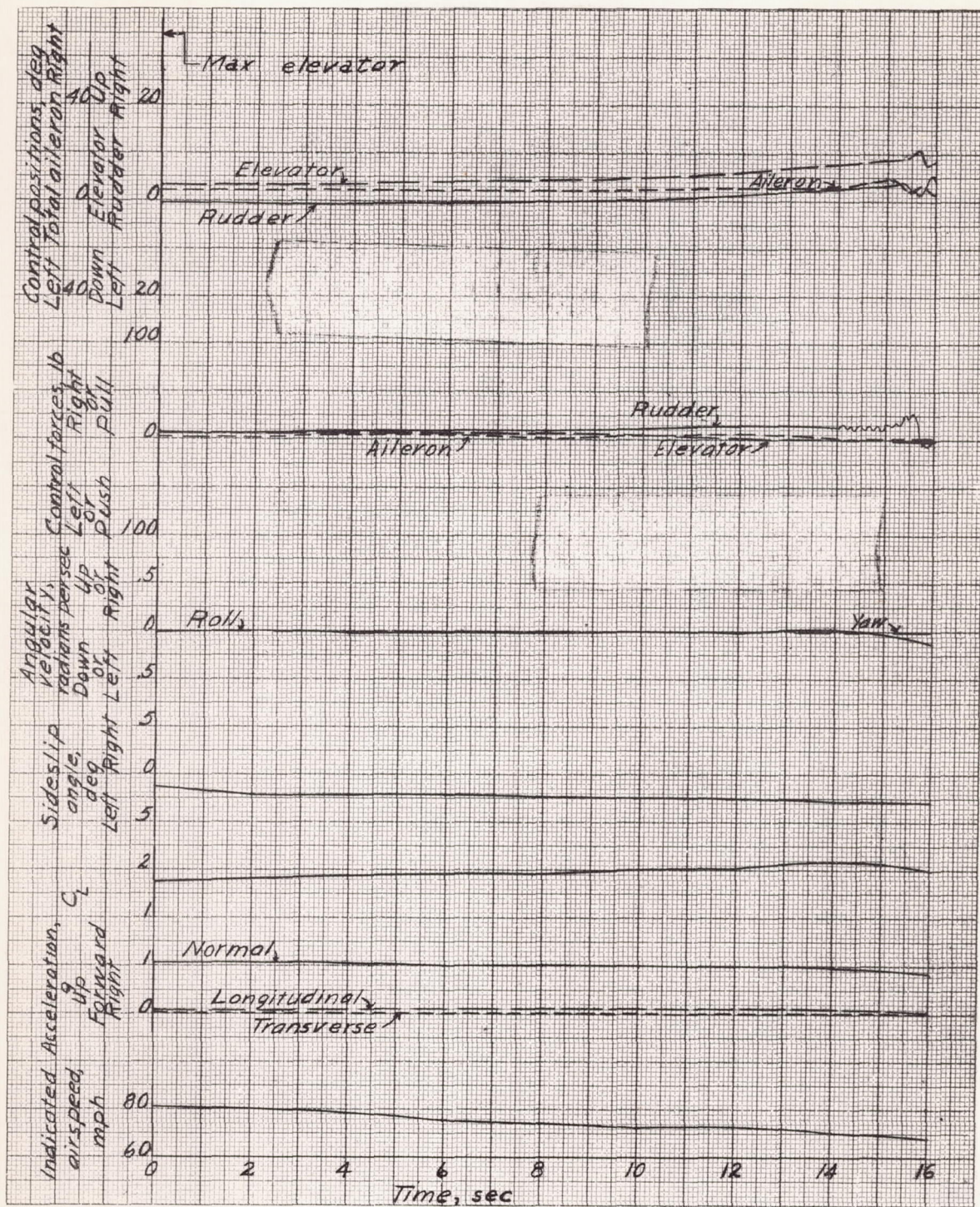

Figure 61.- Time history of a stall in the landing condition (flaps down, landing gear down, hoods closed, cowl flaps closed, power off) center of gravity at 26.8 percent of the mean aerodynamic chord. Curtiss SB2C-1 airplane.

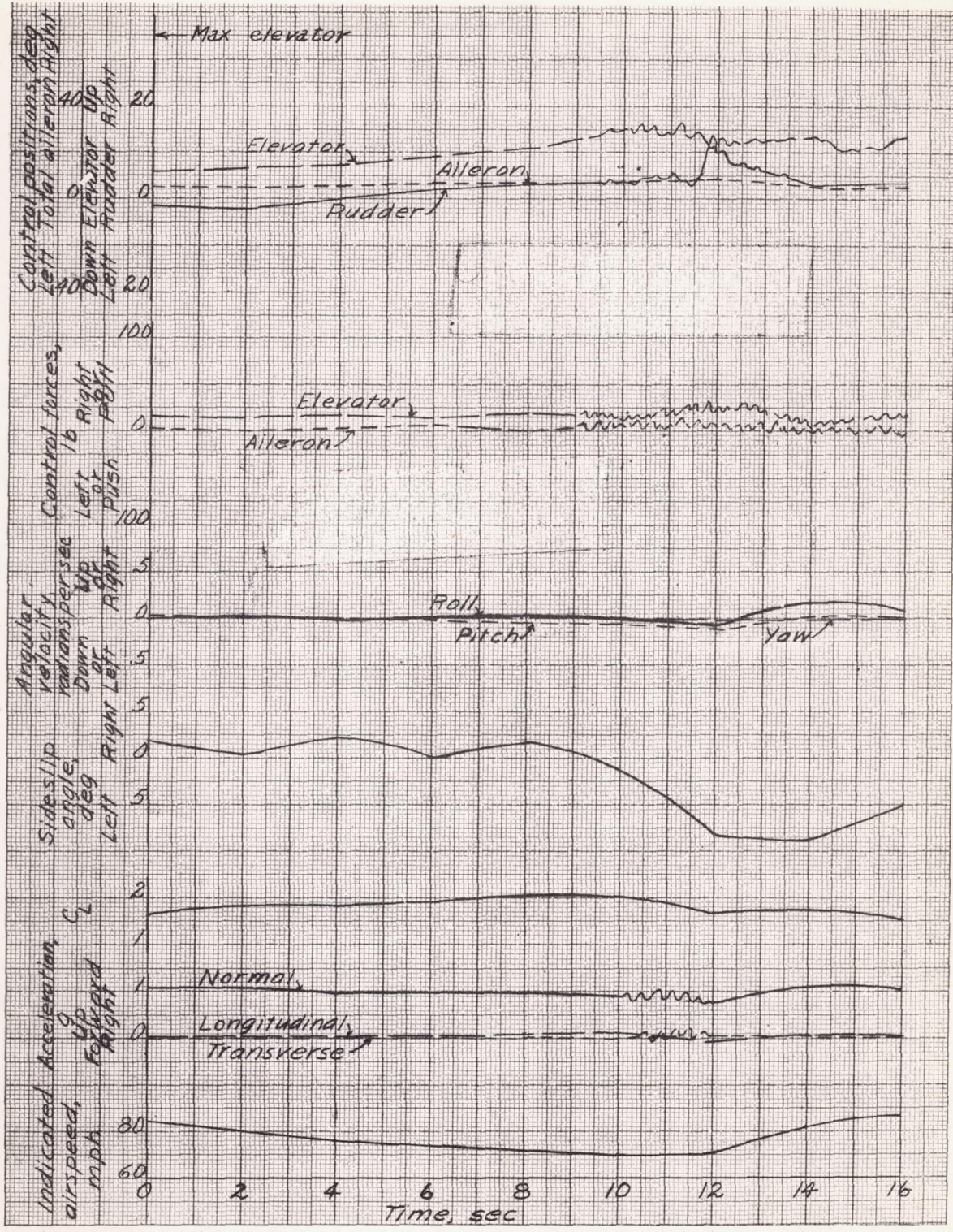

Figure 62.- Time history of a stall in the landing condition (flaps down, landing gear down, front hood closed (?), rear hood closed, cowl flaps open, power off) center of gravity at 24.8 percent of the mean aerodynamic chord. Curtiss SB2C-1 airplane.

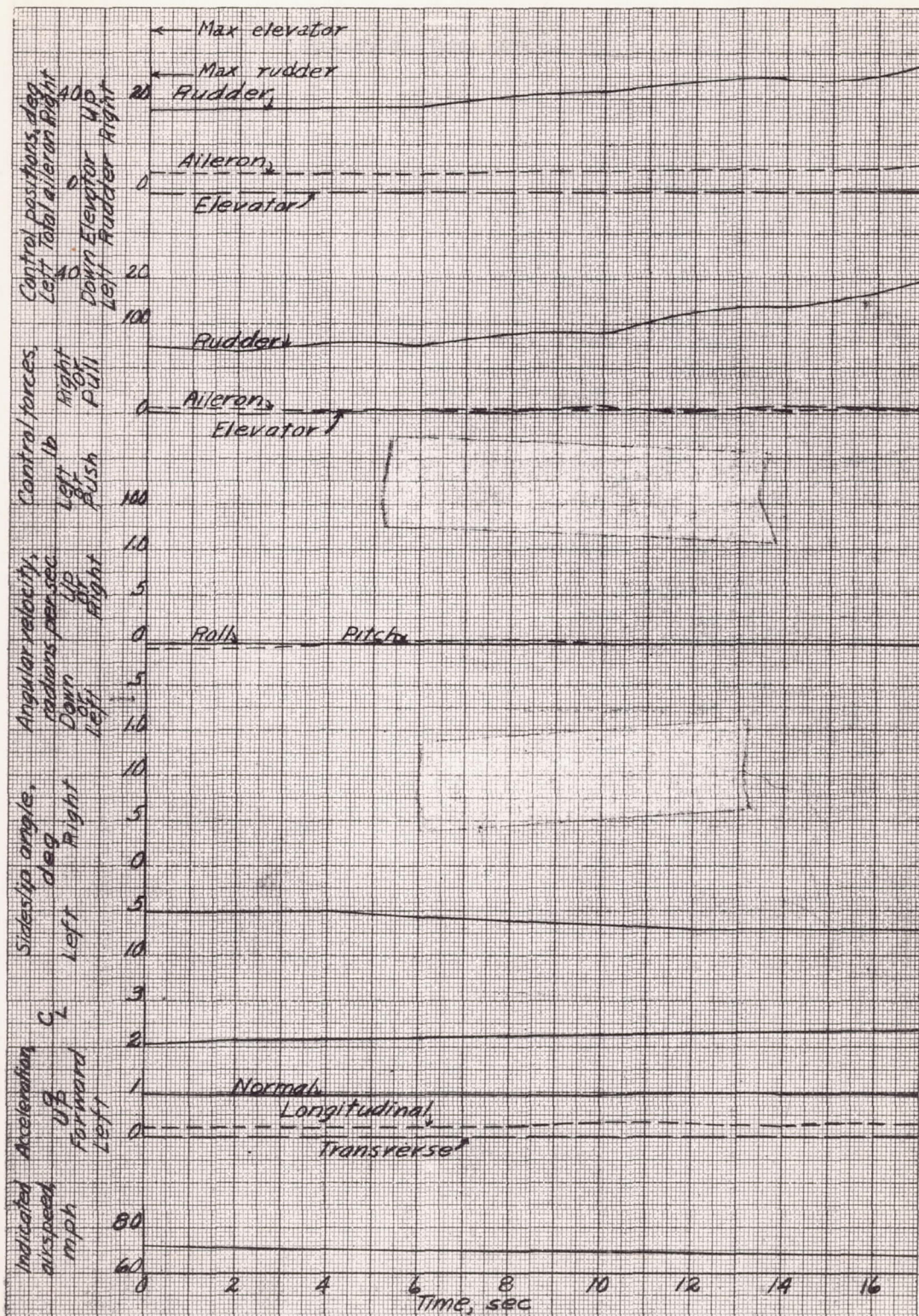

Figure 63.- Time history of a stall in the approach condition (flaps one-half down, landing gear down, front hood open, rear hood closed, cowl flaps closed, partial power) center of gravity at 29.0 percent of the mean aerodynamic chord, bobweight installed. Curtiss SE2C-1 airplane.

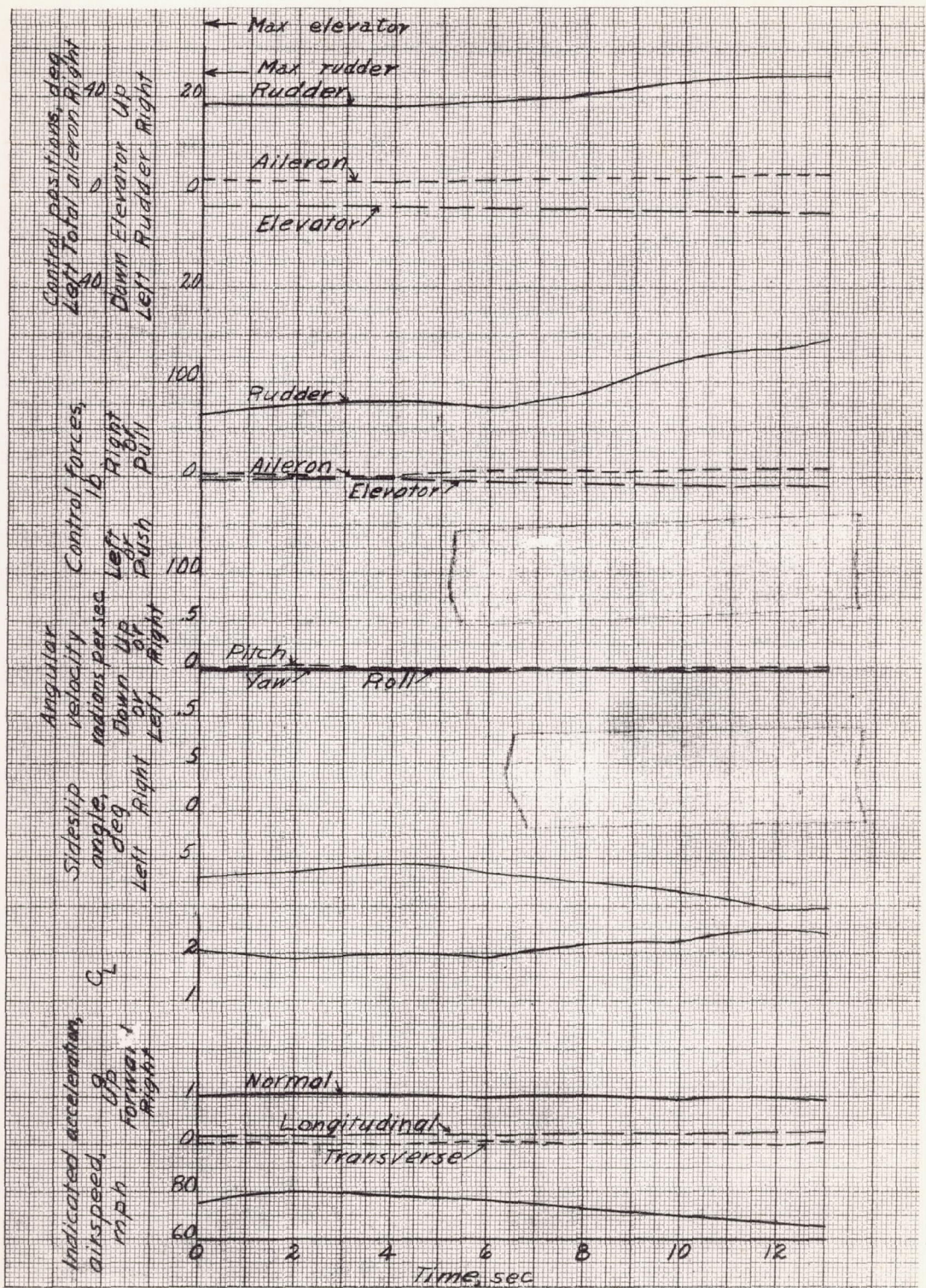

Figure 64.- Time history of a stall in the wave-off condition (flaps down, landing gear down, front hood open, rear hood closed, cowl flaps closed, rated power). Center of gravity at 27.8 percent of the mean aerodynamic chord. Curtiss SB2C-1 airplane.