

FILE COPY  
NO. 1-W

# CASE FILE COPY

MR No. L5G31

NATIONAL ADVISORY COMMITTEE FOR AERONAUTICS

# WARTIME REPORT

ORIGINALLY ISSUED

August 1945 as  
Memorandum Report L5G31

LONGITUDINAL-TRIM TESTS OF A 0.059-SCALE MODEL

OF THE CURTISS-WRIGHT XP-55 AIRPLANE

By George F. MacDougall, Jr., and Leslie E. Schneider

Langley Memorial Aeronautical Laboratory  
Langley Field, Va.

**FILE COPY**  
To be returned to  
the files of the National  
Advisory Committee  
for Aeronautics  
Washington, D. C.



WASHINGTON

NACA WARTIME REPORTS are reprints of papers originally issued to provide rapid distribution of advance research results to an authorized group requiring them for the war effort. They were previously held under a security status but are now unclassified. Some of these reports were not technically edited. All have been reproduced without change in order to expedite general distribution.

MR No. L5G31

NATIONAL ADVISORY COMMITTEE FOR AERONAUTICS

MEMORANDUM REPORT

for the

Air Technical Service Command, Army Air Forces

LONGITUDINAL-TRIM TESTS OF A 0.059-SCALE MODEL

OF THE CURTISS-WRIGHT XP-55 AIRPLANE.

By George F. MacDougall, Jr., and Leslie E. Schneiter

SUMMARY

At the request of the Air Technical Service Command, Army Air Forces, longitudinal-trim tests of a 0.059-scale model of the XP-55 airplane have been performed in the Langley 15-foot free-spinning tunnel. Various revisions in control and airplane configuration were tested with the model mounted on a longitudinal-trim rig to determine modifications which would prevent trim at large positive and negative angles of attack. The tests showed that trim at either erect or inverted flat attitudes could be prevented by installing large wing tips with an extension of each of the wing-tip trimmers in conjunction with a large elevator with deflections of  $\pm 60^\circ$  on the model when the stick was free longitudinally.

INTRODUCTION

Reference 1 reports that during flight tests of the XP-55 airplane late in 1943, an erect stall was attempted with landing gear and flaps extended and engine idling. After starting a normal stall recovery, the airplane pitched down through the vertical diving attitude and continued to pitch until it reached a condition of equilibrium at a negative angle of attack of approximately  $90^\circ$ . The airplane then began to descend vertically at this attitude. Power failed and, as the pilot was unable to maneuver out of the flat inverted attitude, the airplane crashed. The XP-55 is a low-wing, canard-type, pusher airplane with a large amount of sweepback in the wing. The possibility of obtaining trim at either large negative or positive angles of attack with this airplane was

previously indicated by spin tests of a model of the Curtiss-Wright 24-B airplane - a lightweight, full-scale, flying mock-up of the XP-55 airplane. As requested by the Air Technical Service Command, Army Air Forces, and as recommended in reference 1 by the Accident Investigation Board, a model of the XP-55 airplane has been tested in the Langley free-spinning wind tunnel to determine design modifications that would prevent the airplane from trimming at large angles of attack.

Several modifications for improving the longitudinal-trim characteristics of the model appeared possible. The most promising modification appeared to be that of increasing the negative value of the pitching moment when the model was erect and the positive value when the model was inverted by adding area along the trailing edge of the wing near the tips or by adding horizontal fins at the rear of the fuselage. Similar installations had proven beneficial on the 24-B model and, accordingly, the main effort was devoted to improving the longitudinal-trim characteristics of the model in this manner.

The 0.059-scale model was tested on a rig that permitted freedom in pitch in order to determine the effectiveness of numerous modifications in preventing trim at large angles of attack. Tests were performed with the elevator free and with the elevator fixed in order to determine the stick free and the stick fixed trim characteristics. Several representatives of the Curtiss-Wright Corporation were at Langley to witness these tests.

## APPARATUS AND METHODS

### Model

The 0.059-scale model of the Curtiss-Wright XP-55 canard-type airplane and the alternate wing tips and elevator used for the tests were built by the Curtiss-Wright Corporation and were prepared for testing at Langley. A three-view drawing of the original model (small elevator and small wing tips) as tested in the clean condition is shown in figure 1. Leading-edge wing-root spoilers which were on the airplane at the time of the crash were constructed and installed by Langley before the start of the tests (see fig. 2) from information furnished by the

Curtiss-Wright Corporation. The dimensional characteristics of the model were not checked by Langley but were assumed to be in accordance with the drawings. The center-of-gravity location of the airplane was obtained from data furnished by the Curtiss-Wright Corporation. Dimensional characteristics of the airplane with the original (small) and the alternate (large) elevator and with the original (small) and alternate (large) wing tips are given on table I.

Photographs of the original model in the clean and landing conditions are shown in figure 3. A comparison of the original (small) and alternate (large) elevator and wing tips are shown in figures 4 and 5, respectively. Leading-edge wing-tip spoilers, a fence (vertical fin area on the wing), extensions of the wing-tip trimmers, and a typical cowl fin - revisions in model configuration designed in an attempt to prevent trim at large angles of attack - are shown in figures 6 to 9, respectively. The extensions of the wing-tip trimmers were fixed with respect to the wing-tip trimmers.

The model was ballasted with lead weights to obtain the center-of-gravity locations desired, but the scaled-down weight and moments of inertia were not simulated.

#### Wind Tunnel and Testing Technique

The tests were performed in the Langley 15-foot free-spinning tunnel, a description of which is given in reference 2. The model was mounted (as shown in fig. 10) on a wire rig which was fixed in the center of the tunnel. The rig restrained the model about the roll and yaw axes at  $0^\circ$  of roll and yaw but allowed it to oscillate freely about the pitch axis between angles of attack of  $\pm 90^\circ$ . Provision was made for moving the model either forward or rearward on the rig in order to change the longitudinal location of the axis of rotation with respect to the mean aerodynamic chord of the model and for moving weights in the model in order to maintain the center of gravity at the axis of rotation. The elevator was mass-balanced for these tests and, unless otherwise specifically noted in the tables of results, was free to float between the up and down stops.

When placed in the air stream, the model rotated about the pitch axis until it attained a trim angle of

attack and then remained fixed at this position. To determine whether the model would trim at more than one angle of attack for the configuration being tested, the model was rotated from the original trim angle of attack by means of strings attached to the nose and tail of the fuselage. The strings were then released and the model either returned to the first trim angle of attack or rotated until it reached a second trim angle of attack. This procedure was continued until all the trim angles of attack were determined for the configuration being tested.

The tests were performed at a constant airspeed of approximately 40 feet per second. This airspeed for the model corresponded to the approximate rate of descent of the airplane when it was descending in the flat attitude.

The trim angles were measured visually by means of a protractor mounted on a tunnel window which was perpendicular to the pitch axis of the model. Motion pictures were taken of most of the tests and, for the first tests, the trim angles were also measured from the motion-picture film (accuracy of  $\pm 1^\circ$ ). Measurement by the two methods agreed within  $2^\circ$ . The trim angles for the remaining tests, therefore, were measured only visually.

#### TEST CONDITIONS

Longitudinal-trim tests were performed for the original configuration of the model and for various combinations of the modifications shown on figures 4 through 9. The conditions and control deflections tested are indicated in table II. Variations in center-of-gravity location were made for the clean condition (flaps neutral and landing gear retracted) and for individual and combined conditions of landing gear extended, flaps deflected down, and ailerons deflected up for trim.

Flat silk parachutes having a drag coefficient of approximately 0.7 (based upon the canopy area measured with the parachute spread out on a flat surface) were installed on the model for a few tests. The wing-tip trimmers were fixed at neutral for these tests and the towline of the parachute was attached to the outer tip of the wing-tip trimmer. The towline was of such length that the parachute, when opened, would clear the propeller.

The elevator at the nose of the airplane is linked with the stick in such a manner that the trailing edge of the elevator moves up when the stick moves forward. This elevator movement with stick movement is opposite to that for conventional airplanes. The stick movement to climb or dive, however, is the same as that for conventional airplanes, that is, the stick is pushed forward to dive and is pulled rearward to climb.

## RESULTS AND DISCUSSION

The results of the longitudinal-trim tests, presented on table II, show the angles of attack at which the model trimmed in the large positive angle-of-attack range, in the large negative angle-of-attack range, and in the region of the normal-flight angle-of-attack range.

### Original Configuration

The results presented in table IIA show that, in the original configuration for the normal center-of-gravity location, the model would trim only at large positive and negative angles of attack when the elevator was free to float between its original maximum up ( $60^\circ$ ) and down ( $17^\circ$ ) positions with the elevator tab neutral. Results of subsequent tests for various other configurations indicated, however, that trim at angles of attack in the normal-flight region could have been obtained by a small deflection of the elevator trim tab. It was noted during these and the subsequent tests that the elevator trailed with the wind and that it floated up (with respect to the ground) against the stop when the model trimmed at flat erect or inverted attitudes.

The results obtained for the original configuration are generally consistent with the results of tests of the 24-B model and with the results reported in reference 1 in that the models and the airplane trimmed at flat attitudes and at angles of attack in the normal flight range. In addition, the elevator trailed with the wind and floated up against the stop when the model was descending at a flat attitude as was the case for the 24-B model and the XP-55 airplane.

### Effect of Leading-Edge Spoilers

Tests were performed to determine the effect on longitudinal-trim characteristics of removing the leading-edge root spoilers. These tests indicated no effect and accordingly, the root spoilers were not reinstalled for the remainder of the tests. Tests were also performed to determine the effect of installing leading-edge wing-tip spoilers and also indicated little effect (table IIB and C).

### Effect of Fence

The installation of the fence, previously designed by Curtiss-Wright to prevent spanwise flow along the wing, also had no marked effect on the longitudinal-trim characteristics of the model (table IID).

### Effect of Elevator Size

The results presented in table IIE show that the trim characteristics of the model were not appreciably improved when the large elevator was substituted for the small elevator. Elevator travel was unrestricted for these tests. Because of other considerations of longitudinal control, the contractor indicated that the large elevator is to be used on the airplane and the large elevator was, therefore, used on the model for the remainder of the tests.

### Effect of Wing-Tip Size

Installation of the large wing tips, which was essentially an addition of area along the trailing edge of the wing at the tip, tended to prevent trim at large angles of attack (see table IIF). Removal of both wing tips (portion of the wing outboard of the fin and rudder) tended to increase the magnitude of the large trim angle.

The improvement in longitudinal-trim characteristics noted when the large wing tips were installed can be attributed to the fact that the addition of area along the trailing edge of the swept-back wing at the tip increased the negative value of the pitching moment when the model was erect and the positive value when the model was inverted and thereby increased the tendency of the

model to trim at low angles of attack. Similarly, the adverse effect observed when the wing tips were removed can be attributed to a decrease in the value of the pitching moment caused by the removal of the tips.

#### Effect of Extensions of the Wing-Tip Trimmers

The preceding results indicated that a further addition of area along the trailing edge of the wing at the wing tip might be desirable and, accordingly, extensions of the wing-tip trimmers were installed and tested on the model. The results of these tests are presented on table IIG.

Installation of the 5/8-inch (model-scale) extensions of the wing-tip trimmers had a marked beneficial effect on the longitudinal-trim characteristics when the large elevator was free to deflect between  $\pm 60^\circ$  with the elevator tab  $25^\circ$  up. The model would now trim only at angles of attack in the normal-flight range for the normal center-of-gravity location. Installation of smaller extensions of the wing-tip trimmers (3/8-inch model-scale) also improved the trim characteristics but would not always prevent trim at large positive or negative angles of attack.

#### Effect of Cowl Fins

Inasmuch as the rearward portion of the fuselage and the wing tips are approximately the same distance behind the center of gravity, tests were performed to determine whether cowl fins (horizontal fin area on the sides of the rear portion of the fuselage) would also prevent trim at large angles of attack. Installation of the 2- by 4-inch (model-scale) cowl fins prevented trim at large positive and negative angles of attack for the normal center-of-gravity location (table IIH). Tests performed with 1- by 4-inch or smaller cowl fins installed on the model showed that fins larger than 1 by 4 inches (model-scale) were required to prevent trim at large angles of attack. Inasmuch as the cowl fins were believed impracticable because of the excessive size required on the airplane to prevent trim at large angles of attack, tests were not performed to determine the optimum cowl fin.



The results of these tests are also generally consistent with those obtained with the 24-B model. Installation of small cowl fins had no appreciable effect on the trim characteristics of the 24-B model, whereas it would nose over into a steep dive after the spin rotation stopped when wing-fuselage fillets (essentially large cowl fins) were installed.

#### Effect of Parachutes Attached to the Wing Tips

An attempt was then made to prevent trim at large angles of attack by attaching 6.4-foot (full-scale) parachutes to the wing tips with 3.5-foot (full-scale) towlines. Although the installation of the parachutes on the wing tips considerably reduced the magnitude of the trim angle, the results in table III show that larger parachutes would be required in order to prevent trim at angles of attack other than those in the normal-flight range. Inasmuch as appreciably larger parachutes could not be installed on the airplane because of the danger of the parachutes fouling with the propeller, tests were not performed to determine the minimum size of parachute required to prevent trim at any but angles of attack in the normal-flight range.

#### Effect of Center-of-Gravity Location

The results presented in table IIIJ show, as could be expected, that moving the center of gravity forward improved the longitudinal stability of the model (prevented trim at large angles of attack) and that moving the center of gravity rearward impaired the longitudinal stability. It is not feasible, however, to move the center of gravity forward on the airplane.

#### Effect of Elevator Deflection

The trim characteristics of the model with the small wing tips installed were not appreciably changed when the elevator deflection was increased from the original deflections of trailing edge  $17^\circ$  down and  $60^\circ$  up to trailing edge  $60^\circ$  down and  $60^\circ$  up, or when all restrictions on elevator travel were removed with either the large or small elevator installed. (Results on table IIIK.)

A marked beneficial effect was observed (as previously noted), however, when the large elevator was free to deflect between  $\pm 60^\circ$  with the elevator tab neutral and when the large wing tips with the  $5/8$ -inch (model-scale) extensions of the wing-tip trimmers were installed on the model. For this configuration, the model trimmed only in the normal-flight angle-of-attack range for the normal center-of-gravity location.

Results of tests performed with the large elevator fixed at  $60^\circ$  up and at  $60^\circ$  down when the large wing tips with the  $5/8$ -inch (model-scale) extensions of the wing-tip trimmers were installed are also presented in table IIK. When the trailing edge of the elevator was  $60^\circ$  up, the model trimmed at large negative but not large positive angles of attack and, conversely, when the elevator was  $60^\circ$  down the model trimmed at large positive but not large negative angles of attack. These results indicate that the airplane will nose down into a dive from either erect or inverted attitudes when the elevator is full up with respect to the ground.

It was noted during the tests for conditions where the model trimmed both at large angles of attack and at angles of attack in the normal-flight range, that when the model was moved from trim in the normal-flight range, it generally pitched to trim at a large positive or negative angle of attack regardless of whether the elevator was fixed or free. It was observed, however, that the model could be moved appreciably farther from its trim angle of attack in the normal-flight range before pitching to trim at a large angle of attack and that the movement to the large trim angle of attack was considerably slower when the elevator was free than when the elevator was fixed. These results indicate that the model was more stable with the elevator free (stick free) than with the elevator fixed (stick fixed).

It was reported in reference 3 that the XP-55 airplane was longitudinally stable stick free but was longitudinally unstable stick fixed. The results of the present tests are not in complete agreement with these results but do check them qualitatively in that the XP-55 model was longitudinally stable in the normal-flight range for more configurations with the stick free than with the stick fixed.

### Effect of Elevator Tab Deflection

The results on table IIL show that the setting of the elevator tab was an important factor in determining the sign of the large angle of attack at which the model trimmed. As previously noted, the model trimmed at either erect or inverted flat attitudes when the elevator tab was neutral. When the tab was set up, however, the model generally trimmed at large positive but not large negative angles of attack and, conversely, when the elevator tab was set down, the model generally trimmed at large negative but not large positive angles of attack. These results can be explained by the fact that deflection of the tab caused the elevator to float up or down depending on the deflection of the tab. The effect of this elevator deflection was the same as that observed for the elevator deflection tests presented in table IIK. It appears therefore that the pilot in the airplane can use the elevator trim tab to assist in preventing trim at flat attitudes.

### Effect of Aileron Deflections

The results on table IIM show that the magnitude of the large trim angles of attack was reduced when cowl fins were installed and the ailerons were set down together, the reduction in magnitude becoming more pronounced as the center of gravity moved forward. Trim only at angles of attack in the normal-flight range could not be secured by setting ailerons together, however, without forward movement of the center of gravity. There was no appreciable effect on the longitudinal-trim characteristics of deflecting ailerons differentially - moving the stick laterally.

### Effect of Rudder Deflections

The results presented on table IIN show that deflections of the rudders had no appreciable effect upon the longitudinal-trim characteristics of the model.

### Effect of Wing-Tip-Trimmer Deflections

Tests performed with the wing-tip trimmers set together at various angles between  $45^\circ$  up and  $45^\circ$  down

showed that the magnitude of the trim angles could be changed, but that trim at large angles of attack could not be prevented by deflections of the wing-tip trimmers (see table IIO).

#### Effect of Flaps and Landing Gear

The results of the tests performed to determine the effects of individual and combined deflection of the flaps and extension of the landing gear are presented in tables IIP, Q, and R. There was little effect of setting the flaps down or of extending the landing gear either individually or together when the extensions of the wing-tip trimmers were not installed on the model. Some of the results presented show that the model trimmed at large positive angles of attack when the flaps and landing gear were retracted and at large negative angles of attack when the flaps were set down and the landing gear was extended. It will be noted, however, that the setting of the elevator tab was also changed from up to down for these tests and the change in the sign of the large trim angle can therefore, as previously noted, be attributed to the change in elevator tab setting. These results of the flap and landing gear tests are also in agreement with those obtained on the airplane. The pilot reported in reference 1 that neither extending or retracting the landing gear nor deflecting or retracting the flaps had an appreciable effect on the trim angle of the airplane when it was descending in the flat inverted attitude.

Extending the landing gear alone when the extensions of the wing-tip trimmers were installed decreased the tendency of the model to trim at large positive angles of attack. Setting the flaps down when the extensions of the wing-tip trimmers were installed increased the tendency of the model to trim at large negative angles of attack. Setting the ailerons up for trim decreased the tendency of the model to trim at large negative angles of attack. The reduction in trim at large negative angles of attack is caused by the positive pitching moment contributed by the ailerons in the up position. With the 5/8-inch (model-scale) extensions of the wing-tip trimmers installed, there was less tendency to trim at flat erect attitudes when the model was in the landing condition than when the model was in the clean condition. This decreased tendency of the model to trim at large positive angles of

attack when it was in the landing condition can be attributed to the negative pitching moment contributed by the flaps and landing gear in the extended position.

### Final Configuration

The results of the preceding tests indicated that the longitudinal-trim characteristics of the model were generally satisfactory when both the large elevator with deflections of  $\pm 60^\circ$  and appropriate tab deflections and the large wing tips with the 5/8-inch (model-scale) extensions of the wing-tip trimmers were installed. A comparison of the original model and the model so modified is shown on figure 11. Inasmuch as the preceding revision in airplane configuration was considered practicable by the contractor for flight use, tests were performed to determine whether the longitudinal-trim characteristics of the modified model would be satisfactory for all aileron-elevator configurations. Results of these tests are presented on table IIS.

There was no appreciable effect of lateral deflection of the stick for any longitudinal deflection of the stick. When the stick was neutral longitudinally, the model trimmed at large positive and negative angles of attack as well as at angles of attack in the normal-flight range. The model trimmed either at angles of attack in the normal-flight range or at large positive or negative angles of attack, depending upon the longitudinal location of the stick, when the stick was full back or full forward longitudinally. When the stick was free longitudinally, the model generally trimmed only at angles of attack in the normal-flight range. These results indicate that if the XP-55 airplane attains flat attitudes, the elevator will trail with the wind and float up (with respect to the ground) against the stop and, inasmuch as the elevator is in the nose, the airplane will then nose down into a dive. If the stick is free longitudinally, the airplane will trim only at angles of attack in the normal-flight range and the pilot will be able to regain control.

### CONCLUSION

The results of the longitudinal-trim tests of a 0.059-scale model of the XP-55 airplane indicate that the

airplane will not trim at flat attitudes when the stick is free longitudinally if the large wing tips with an extension of each of the wing-tip trimmers and a large elevator with deflections of  $\pm 60^\circ$  are installed on the airplane.

Langley Memorial Aeronautical Laboratory  
National Advisory Committee for Aeronautics  
Langley Field, Va.

## REFERENCES

1. Anon.: Accident Investigation Report - XP-55 (CW-24).  
C-W St. Louis Serial No. 2913, A.A.F. Serial  
No. 42-78845, Curtiss-Wright Corp., Airplane Div.  
(St. Louis), Nov. 30, 1943.
2. Zimmerman, C. H.: Preliminary Tests in the N.A.C.A.  
Free-Spinning Wind Tunnel. NACA Rep. No. 557, 1936.
3. Biebel, William J.: Full-Scale Tunnel Tests of a Flying  
Model of the Curtiss XP-55 Airplane. NACA MR,  
Jan. 29, 1943.

TABLE I.- DIMENSIONAL CHARACTERISTICS OF THE CURTISS-WRIGHT XP-55 AIRPLANE

Length over all, ft . . . . .		29.58
Propeller diameter, ft . . . . .		10.0
Wing: . . . . .	With large wing tips	With small wing tips
Span, ft . . . . .	41.02	40.57
Area, sq ft . . . . .	213.2	208.3
Section, root . . . . .	C-W 6500-0015	C-W 6500-0015
Section, tip . . . . .	C-W 6500-0015	C-W 6500-0015
Root chord incidence, deg . . . . .	4.25	4.25
Tip chord incidence, deg . . . . .	0.75	0.75
Aspect ratio . . . . .	7.88	7.91
Sweepback at 25 percent chord line, deg . . . . .	28.5	28.5
Dihedral at 25 percent chord line, deg . . . . .	4.5	4.5
Taper ratio . . . . .	3.88	3.88
Mean aerodynamic chord, in. . . . .	67.44	67.69
Leading edge of M.A.C. rearward of leading edge of root chord, in. . . . .	62.88	61.08
Leading edge of root chord rearward of nose of airplane, ft . . . . .	11.23	11.23
Ailerons:		
Area rearward of hinge line, percent of wing area (with large wing tips) . . . . .		7.13
Span, percent of wing semispan (with large wing tips) . . . . .		38.44
Chord, percent of wing chord . . . . .		20.0
Flaps:		
Type . . . . .		Split
Chord, ft . . . . .		1.11
Span, percent of wing semispan (with large wing tips) . . . . .		31.72

MR No. L5G31



TABLE I.- DIMENSIONAL CHARACTERISTICS - Concluded

Large horizontal tail surfaces:

Total area, sq ft . . . . .	21.52
Span, ft . . . . .	11.31
Distance from normal center of gravity to elevator hinge line, ft . . . . .	15.95
Tab chord, percent elevator chord . . . . .	25.00

Small horizontal tail surface:

Total area, sq ft . . . . .	18.63
Span, ft . . . . .	8.92

Vertical tail surfaces:

Total exposed area, sq ft . . . . .	27.80
Fin area forward of hinge line, sq ft . . . . .	14.80
Rudder area rearward of hinge line, sq ft . . . . .	13.00
Rudder area, percent of exposed vertical tail area . . . . .	46.80
Over-all height, ft . . . . .	4.58
Aspect ratio . . . . .	1.37
Distance from normal center of gravity to rudder hinge line, ft . . . . .	7.97
Distance from rudder hinge line to plane of symmetry, ft . . . . .	16.56

NATIONAL ADVISORY  
COMMITTEE FOR AERONAUTICS

MR No. L5931

TABLE II - LONGITUDINAL-TRIM CHARACTERISTICS OF THE XP-55 MODEL.

Model configuration												Trim angle of attack (deg)		
Rudders	Aileron deflection (deg)	Wing-tip trimmer deflection (deg)	Elevator deflection (deg)	Elevator tab deflection (deg)	Elevator size	Wing tip size	Landing gear	Flap deflection (deg)	Center-of-gravity location (percent M.A.C.)	Cowl fin size (in., model-scale)	Modifications	Large positive	Large negative	Normal flight range
A. Original configuration														
Neutral	0	0	(a)	0	Small	Small	Up	0	11.7	None	None	58	70	(b)
B. Effect of leading-edge root spoilers														
Neutral	10 up	0	(c)	0	Large	Small	Down	45 down	11.7	$\frac{3}{4}$ by 4	Spoilers installed (fig. 2)	(b)	28	(b)
Do--	10 up	0	(c)	0	- do -	-do-	-do-	45 down	11.7	$\frac{3}{4}$ by 4	None	(b)	32	(b)
Do--	10 up	0	(c)	0	-do-	-do-	-do-	45 down	18.0	$\frac{3}{4}$ by 4	Spoilers installed (fig. 2)	60	39	(b)
Do--	10 up	0	(c)	0	-do-	-do-	-do-	45 down	18.0	$\frac{3}{4}$ by 4	None	66	35	(b)
C. Effect of leading-edge wing-tip spoilers														
Neutral	0	0	(c)	25 up	Large	Small	Up	0	11.7	None	Spoiler 1 installed (fig. 6)	61	64	-2
Do--	0	0	(c)	25 up	-do-	-do-	-do-	0	11.7	-do-	Spoilers 1 and 2 installed (fig. 6)	61	No test	0
Do--	0	0	(c)	25 up	-do-	-do-	-do-	0	11.7	-do-	Spoilers removed	59	62	-2
D. Effect of a fence														
Neutral	0	0	(c)	25 up	Large	Small	Up	0	11.7	$\frac{3}{4}$ by 4	Fence installed (fig. 7)	53	(b)	-1
Do--	0	0	(c)	25 up	-do-	-do-	-do-	0	11.7	$\frac{3}{4}$ by 4	None	57	(b)	-1
Do--	0	0	(c)	25 up	-do-	-do-	-do-	0	11.7	None	Fence installed (fig. 7)	62	-62	0
Do--	0	0	(c)	25 up	-do-	-do-	-do-	0	11.7	-do-	None	59	-62	-2
E. Effect of elevator size														
Neutral	0	0	(d)	0	Small	Small	Up	0	11.7	1 by 4	None	(b)	22, 32	(b)
Do--	0	0	(d)	0	Large	-do-	-do-	0	11.7	1 by 4	-do-	(b)	28	(b)

<sup>a</sup>Free, from trailing edge 17° down to 60° up

<sup>b</sup>Model did not trim in this angle-of-attack range

<sup>c</sup>Free, from trailing edge 60° down to 60° up

<sup>d</sup>Free, no stops

NATIONAL ADVISORY  
COMMITTEE FOR AERONAUTICS

MR No. 15521

TABLE II - Continued.  
LONGITUDINAL-TRIM CHARACTERISTICS OF THE XP-55 MODEL.

Model configuration												Trim angle of attack (deg)		
Rudders	Aileron deflection (deg)	Wing-tip trimmer deflection (deg)	Elevator deflection (deg)	Elevator tab deflection (deg)	Elevator size	Wing tip size	Landing gear	Flap deflection (deg)	Center-of-gravity location (percent M.A.C.)	Cowl fin size (in., model-scale)	Modifications	Large positive	Large negative	Normal flight range
F. Effect of wing-tip size														
Neutral	0	0	(c)	25 up	Large	Large	Up	0	11.7	None	None	55	(b)	-2
Do--	0	0	(c)	25 up	-do-	Small	-do-	0	11.7	-do-	-do-	61	(b)	-3
Do--	0	0	(c)	25 up	-do-	-do-	-do-	0	11.7	-do-	-do-	59	62	-2
Do--	0	0	(e)	25 up	-do-	Large	-do-	0	11.7	-do-	-do-	63	(b)	-2
Do--	0	0	(e)	25 up	-do-	Small	-do-	0	11.7	-do-	-do-	64	60	-1
Do--	0	0	(d)	0	Small	Large	-do-	0	11.7	-do-	-do-	58	58	(b)
Do--	0	0	(d)	0	-do-	Small	-do-	0	11.7	-do-	-do-	59	62	(b)
Do--	0	0	(e)	25 down	Large	Large	-do-	0	11.7	-do-	-do-	(b)	54	-14
Do--	0	0	(e)	25 down	-do-	Small	-do-	0	11.7	-do-	-do-	58	52	-10
Do--	0	0	(e)	25 up	-do-	Large	-do-	0	14.8	-do-	-do-	65	(b)	-2
Do--	0	0	(e)	25 up	-do-	Small	-do-	0	14.8	-do-	-do-	64	65	-2
Do--	0	0	(c)	25 down	-do-	Large	-do-	0	14.8	-do-	-do-	(b)	58	(b)
Do--	0	0	(c)	25 down	-do-	Small	-do-	0	14.8	-do-	-do-	68	64	(b)
Do--	0	0	(c)	25 up	-do-	-do-	-do-	0	11.7	$\frac{3}{4}$ by 4	-do-	57	(b)	-1
Do--	0	0	(c)	25 up	-do-	None	-do-	0	11.7	$\frac{3}{4}$ by 4	-do-	64	(b)	(b)
Do--	0	0	(c)	25 up	-do-	Large	-do-	0	11.7	None	-do-	59	62	-2
Do--	0	0	(c)	25 up	-do-	None	-do-	0	11.7	-do-	-do-	58	74	(b)
G. Effect of extensions of the wing-tip trimmers														
Neutral	0	0	(e)	25 up	Large	Large	Up	0	11.7	None	None	63	(b)	-2
Do--	0	0	(c)	25 up	-do-	-do-	-do-	0	11.7	-do-	$\frac{5}{8}$ -in. extensions installed (fig. 8)	(b)	(b)	+2
Do--	0	0	(c)	25 up	-do-	-do-	-do-	0	11.7	-do-	None	55	(b)	-2
Do--	0	0	(c)	25 up	-do-	-do-	-do-	0	11.7	-do-	$\frac{5}{8}$ -in. extensions installed (fig. 8)	(b)	(b)	-3
Do--	10 up	0	(e)	25 up	-do-	-do-	Down	45 down	11.7	-do-	None	64	(b)	-6
Do--	10 up	0	(c)	25 up	-do-	-do-	-do-	45 down	11.7	-do-	$\frac{5}{8}$ -in. extensions installed (fig. 8)	(b)	(b)	-8
Do--	0	0	(c)	25 up	-do-	-do-	Up	0	11.7	-do-	-do-	(b)	(b)	-3

<sup>b</sup>Model did not trim in this angle-of-attack range

<sup>c</sup>Free, from trailing edge 60° down to 60° up

<sup>d</sup>Free, no stops

<sup>e</sup>Free, from trailing edge 60° down to 70° up

NATIONAL ADVISORY  
COMMITTEE FOR AERONAUTICS

TABLE II- Continued.  
LONGITUDINAL-TRIM CHARACTERISTICS OF THE XP-55 MODEL.

Model configuration												Trim angle of attack (deg)		
Rudders	Aileron deflection (deg)	Wing-tip trimmer deflection (deg)	Elevator deflection (deg)	Elevator tab deflection (deg)	Elevator size	Wing tip size	Landing gear	Flap deflection (deg)	Center-of-gravity location (percent M.A.C.)	Cowl fin size (in., model-scale)	Modifications	Large positive	Large negative	Normal flight range
G. Effect of extensions of the wing-tip trimmers. (Continued)														
Do--	0	0	(e)	25 up	-do-	-do-	-do-	0	11.7	-do-	$\frac{3}{8}$ -in. extensions installed (Fig. 8)	57	(b)	-2
Do--	0	0	(c)	25 up	-do-	-do-	-do-	0	11.7	-do-	-do-	(b)	(b)	-4
Do--	10 up	0	(c)	25 up	-do-	-do-	Down	45 down	11.7	-do-	$\frac{5}{8}$ -in. extensions installed (Fig. 8)	(b)	(b)	-8
Do--	10 up	0	(e)	25 up	-do-	-do-	-do-	45 down	11.7	-do-	$\frac{3}{8}$ -in. extensions installed (Fig. 8)	45	(b)	-6
Do--	10 up	0	(e)	25 down	-do-	-do-	-do-	45 down	11.7	-do-	-do-	(b)	38	-14
Do--	10 up	0	(e)	25 down	-do-	-do-	-do-	45 down	11.7	-do-	None	(b)	49	-17
Do--	0	0	(e)	25 up	-do-	-do-	-do-	0	11.7	-do-	$\frac{3}{8}$ -in. extensions installed (Fig. 8)	(b)	(b)	-2
Do--	0	0	(e)	25 up	-do-	-do-	-do-	0	11.7	-do-	None	64	(b)	-2
Do--	10 up	0	(c)	25 up	-do-	-do-	-do-	45 down	11.7	$\frac{3}{4}$ by $\frac{3}{4}$	$\frac{3}{8}$ -in. extensions installed (Fig. 8)	(b)	(b)	-7
Do--	0	0	(e)	25 up	-do-	-do-	Up	0	14.8	None	None	65	(b)	-2
Do--	0	0	(a)	25 up	-do-	-do-	-do-	0	14.8	-do-	$\frac{5}{8}$ -in. extensions installed (Fig. 8)	54	(b)	1,-2
Do--	0	0	(a)	25 up	-do-	-do-	-do-	0	14.8	2 by $\frac{3}{4}$	-do-	(b)	(b)	-3
Do--	0	0	(a)	25 up	-do-	-do-	-do-	0	14.8	2 by $\frac{3}{4}$	1-in. extensions installed (Fig. 8)	(b)	(b)	-1
H. Effect of cowl fins														
Neutral	0	0	(d)	0	Small	Large	Up	0	11.7	None	None	58	58	(b)
Do--	0	0	(d)	0	-do-	-do-	-do-	0	11.7	2 by 4	-do-	(b)	(b)	-6
Do--	0	0	(d)	0	-do-	-do-	-do-	0	11.7	1 by 4	-do-	45	(b)	-8
Do--	0	0	(c)	0	Large	Small	-do-	0	11.7	$\frac{7}{16}$ by 4	-do-	55	30	(b)
Do--	0	0	(c)	0	-do-	-do-	-do-	0	11.7	$\frac{5}{16}$ by 4	-do-	55	47	(b)
Do--	0	0	(c)	0	-do-	-do-	-do-	0	11.7	$\frac{3}{4}$ by 4	-do-	50	30	(b)

<sup>a</sup>Free, from trailing edge 17° down to 60° up

<sup>b</sup>Model did not trim in this angle-of-attack range

<sup>c</sup>Free, from trailing edge 60° down to 60° up

<sup>d</sup>Free, no stops

<sup>e</sup>Free, from trailing edge 60° down to 70° up

NATIONAL ADVISORY  
COMMITTEE FOR AERONAUTICS

TABLE II- Continued.  
LONGITUDINAL-TRIM CHARACTERISTICS OF THE XP-55 MODEL.

Model configuration												Trim angle of attack (deg)		
Rudders	Aileron deflection (deg)	Wing-tip trimmer deflection (deg)	Elevator deflection (deg)	Elevator tab deflection (deg)	Elevator size	Wing tip size	Landing gear	Flap deflection (deg)	Center-of-gravity location (percent M.A.C.)	Cowl fin size (in., model-scale)	Modifications	Large positive	Large negative	Normal flight range
H. Effect of cowl fins. (Continued)														
Do--	0	0	(c)	25 up	-do-	-do-	-do-	0	11.7	None	-do-	59	62	-2
Do--	0	0	(c)	25 up	-do-	-do-	-do-	0	11.7	$\frac{3}{4}$ by 4	-do-	53	(b)	-1
Do--	0	0	(c)	25 up	-do-	-do-	-do-	0	11.7	None	-do-	62	62	0
Do--	0	0	(c)	25 up	-do-	-do-	-do-	0	11.7	$\frac{3}{4}$ by 4	-do-	57	(b)	-1
Do--	0	0	(f)	25 down	-do-	-do-	-do-	0	14.8	None	-do-	65	60	(b)
Do--	0	0	(f)	25 down	-do-	-do-	-do-	0	14.8	$\frac{3}{4}$ by 4	-do-	(b)	41	(b)
Do--	0	0	(a)	25 down	-do-	Large	-do-	0	14.8	None	$\frac{5}{8}$ -in. extensions installed (Fig.8)	(b)	52	(b)
Do--	0	0	(a)	25 down	-do-	-do-	-do-	0	14.8	$\frac{3}{4}$ by $3\frac{3}{4}$	-do-	(b)	26	-18
Do--	0	0	(a)	25 up	-do-	-do-	-do-	0	14.8	None	-do-	54	(b)	0
Do--	0	0	(a)	25 up	-do-	-do-	-do-	0	14.8	2 by $3\frac{3}{4}$	-do-	(b)	(b)	-3
Do--	0	0	(a)	25 up	-do-	-do-	-do-	0	14.8	2 by $3\frac{3}{4}$	1-in. extensions installed (Fig.8)	(b)	(b)	-1
Do--	10 up	0	(e)	25 up	-do-	-do-	Down	45 down	11.7	None	$\frac{3}{8}$ -in. extensions installed (Fig.8)	45	(b)	-6
Do--	10 up	0	(c)	25 up	-do-	-do-	-do-	45 down	11.7	$\frac{3}{4}$ by $3\frac{3}{4}$	-do-	(b)	(b)	-7
Do--	10 up	0	(c)	0	-do-	Small	-do-	45 down	18.0	$\frac{3}{4}$ by 4	None	60	39	(b)
I. Effect of wing tip parachutes.														
Neutral	10 up	0	(c)	25 down	Large	Large	Down	45 down	14.8	None	6.4-foot, full-scale, parachute attached to left wing tip	(b)	36	(b)
Do--	10 up	0	(c)	25 down	-do-	-do-	-do-	45 down	14.8	-do-	6.4-foot, full-scale, parachute attached to each wing tip	(b)	32	(b)
Do--	10 up	0	(c)	25 down	-do-	-do-	-do-	45 down	14.8	-do-	Parachutes removed	(b)	51	(b)

<sup>a</sup>Free, from trailing edge 17° down to 60° up

<sup>b</sup>Model did not trim in this angle-of-attack range

<sup>c</sup>Free, from trailing edge 60° down to 60° up

<sup>e</sup>Free, from trailing edge 60° down to 70° up

<sup>f</sup>Free, from trailing edge 70° down to 70° up

NATIONAL ADVISORY  
COMMITTEE FOR AERONAUTICS

MR No. 1.5631

TABLE II - Continued.  
LONGITUDINAL-TRIM CHARACTERISTICS OF THE XP-55 MODEL.

MR No. 15331

Model configuration												Trim angle of attack (deg)		
Rudders	Aileron deflection (deg)	Wing-tip trimmer deflection (deg)	Elevator deflection (deg)	Elevator tab deflection (deg)	Elevator size	Wing tip size	Landing gear	Flap deflection (deg)	Center-of-gravity location (percent M.A.C.)	Cowl fin size (in., model-scale)	Modifications	Large positive	Large negative	Normal flight range
J. Effect of center-of-gravity location.														
Neutral	0	0	0	0	Small	Small	Up	0	-7.1	None	None	(b)	(b)	-9
Do--	0	0	0	0	-do-	-do-	-do-	0	-0.8	-do-	-do-	54	53	-11
Do--	0	0	(d)	0	-do-	-do-	-do-	0	-7.1	-do-	-do-	(b)	(b)	-8
Do--	0	0	(d)	0	-do-	-do-	-do-	0	-0.8	-do-	-do-	(b)	(b)	-8
Do--	0	0	(d)	0	-do-	-do-	-do-	0	11.7	-do-	-do-	59	62	(b)
Do--	0	0	(c)	25 up	Large	-do-	-do-	0	-0.8	$\frac{3}{4}$ by 4	-do-	(b)	(b)	-3
Do--	0	0	(c)	25 up	-do-	-do-	-do-	0	5.5	$\frac{3}{4}$ by 4	-do-	25	(b)	-2
Do--	0	0	(c)	25 up	-do-	-do-	-do-	0	8.6	$\frac{3}{4}$ by 4	-do-	37	(b)	-3
Do--	0	0	(c)	25 up	-do-	-do-	-do-	0	11.7	$\frac{3}{4}$ by 4	-do-	57	(b)	-1
Do--	0	0	(c)	25 up	-do-	-do-	-do-	0	18.0	$\frac{3}{4}$ by 4	-do-	65	(b)	0
K. Effect of elevator deflection.														
Neutral	0	0	(a)	10 up	Small	Small	Up	0	8.6	None	None	No test	No test	0
Do--	0	0	(d)	10 up	-do-	-do-	-do-	0	8.6	-do-	-do-	No test	No test	0
Do--	0	0	(a)	0	-do-	-do-	-do-	0	11.7	-do-	-do-	58	70	(b)
Do--	0	0	(d)	0	-do-	-do-	-do-	0	11.7	-do-	-do-	59	62	(b)
Do--	0	0	(c)	0	Large	-do-	-do-	0	11.7	1 by 4	-do-	(b)	28	(b)
Do--	0	0	(d)	0	-do-	-do-	-do-	0	11.7	1 by 4	-do-	(b)	28	(b)
Do--	0	0	(f)	25 up	-do-	-do-	-do-	0	14.8	None	-do-	64	(b)	-2
Do--	0	0	(d)	25 up	-do-	-do-	-do-	0	14.8	-do-	-do-	64	(b)	-2
Full left	0	0	(c)	0	-do-	Large	-do-	0	11.7	-do-	$\frac{5}{8}$ -in. extensions installed (Fig. 8)	(b)	No test	-11
Do--	(g)	0	(c)	0	-do-	-do-	-do-	0	11.7	-do-	-do-	(b)	(b)	-5

<sup>a</sup>Free, from trailing edge 17° down to 60° up

<sup>b</sup>Model did not trim in this angle-of-attack range

<sup>c</sup>Free, from trailing edge 60° down to 60° up

<sup>d</sup>Free, no stops

<sup>f</sup>Free, from trailing edge 70° down to 70° up

<sup>g</sup>Right aileron 28° up, left aileron 9° down

NATIONAL ADVISORY  
COMMITTEE FOR AERONAUTICS

TABLE II - Continued.  
LONGITUDINAL-TRIM CHARACTERISTICS OF THE XP-55 MODEL.

Model configuration												Trim angle of attack (deg)		
Rudders	Aileron deflection (deg)	Wing-tip trimmer deflection (deg)	Elevator deflection (deg)	Elevator tab deflection (deg)	Elevator size	Wing tip size	Landing gear	Flap deflection (deg)	Center-of-gravity location (percent M.A.C.)	Cowl fin size (in., model-scale)	Modifications	Large positive	Large negative	Normal flight range
K. Effect of elevator deflection. (Continued)														
Do--	(h)	0	(c)	0	-do-	-do-	-do-	0	11.7	-do-	-do-	No test	No test	-5
Do--	0	0	60 up	25 down	-do-	-do-	-do-	0	11.7	-do-	-do-	(b)	56	(b)
Do--	(g)	0	60 up	25 down	-do-	-do-	-do-	0	11.7	-do-	-do-	(b)	65	(b)
Do--	(h)	0	60 up	25 down	-do-	-do-	-do-	0	11.7	-do-	-do-	(b)	54	(b)
Do--	0	0	60 down	25 up	-do-	-do-	-do-	0	11.7	-do-	-do-	60	(b)	-3
Do--	(g)	0	60 down	25 up	-do-	-do-	-do-	0	11.7	-do-	-do-	62	(b)	-3
Do--	(h)	0	60 down	25 up	-do-	-do-	-do-	0	11.7	-do-	-do-	60	(b)	+2
Neutral	0	0	(a)	0	Small	-do-	-do-	0	8.6	-do-	None	67	67	-12
Do--	0	0	0	0	-do-	-do-	-do-	0	8.6	-do-	-do-	65	75	-6
Do--	0	0	(d)	0	-do-	-do-	-do-	0	-7.1	-do-	-do-	(b)	(b)	-8
Do--	0	0	0	0	-do-	-do-	-do-	0	-7.1	-do-	-do-	(b)	(b)	-9
Do--	0	0	(d)	0	-do-	-do-	-do-	0	-0.8	-do-	-do-	(b)	(b)	-8
Do--	0	0	0	0	-do-	-do-	-do-	0	-0.8	-do-	-do-	54	53	-9
Full left	(g)	0	60 up	25 down	Large	Large	-do-	0	11.7	-do-	$\frac{5}{8}$ -in. extensions installed (Fig.8)	(b)	65	(b)
Do--	(g)	0	0	0	-do-	-do-	-do-	0	11.7	-do-	-do-	75	70	-5
Do--	0	0	(c)	0	-do-	-do-	-do-	0	11.7	-do-	-do-	(b)	No test	-11
Do--	0	0	0	0	-do-	-do-	-do-	0	11.7	-do-	-do-	73	74	-4
Do--	(h)	0	(c)	0	-do-	-do-	-do-	0	11.7	-do-	-do-	No test	No test	-5
Do--	(h)	0	0	0	-do-	-do-	-do-	0	11.7	-do-	-do-	77	73	-5
L. Effect of elevator tab deflection.														
Neutral	0	0	(a)	5 up	Large	Small	Up	0	11.7	$\frac{3}{4}$ by 4	None	52	(b)	-8
Do--	0	0	(a)	10 up	-do-	-do-	-do-	0	11.7	$\frac{3}{4}$ by 4	-do-	52	(b)	-6
Do--	0	0	(a)	15 up	-do-	-do-	-do-	0	11.7	$\frac{3}{4}$ by 4	-do-	57	(b)	-5
Do--	0	0	(a)	20 up	-do-	-do-	-do-	0	11.7	$\frac{3}{4}$ by 4	-do-	57	(b)	-2
Do--	0	0	(a)	25 up	-do-	-do-	-do-	0	11.7	$\frac{3}{4}$ by 4	-do-	59	(b)	-1
Do--	0	0	(f)	25 up	-do-	-do-	-do-	0	14.8	None	-do-	64	(b)	-2

<sup>a</sup>Free, from trailing edge 17° down to 60° up

<sup>b</sup>Model did not trim in this angle-of-attack range

<sup>c</sup>Free, from trailing edge 60° down to 60° up

<sup>d</sup>Free, no stops

<sup>f</sup>Free, from trailing edge 70° down to 70° up

<sup>g</sup>Right aileron 28° up, left aileron 9° down

<sup>h</sup>Right aileron 9° down, left aileron 28° up

NATIONAL ADVISORY  
COMMITTEE FOR AERONAUTICS

TABLE II - Continued.  
LONGITUDINAL-TRIM CHARACTERISTICS OF THE XP-55 MODEL.

Model configuration												Trim angle of attack (deg)		
Rudders	Aileron deflection (deg)	Wing-tip trimmer deflection (deg)	Elevator deflection (deg)	Elevator tab deflection (deg)	Elevator size	Wing tip size	Landing gear	Flap deflection (deg)	Center-of-gravity location (percent M.A.C.)	Cowl fin size (in., model-scale)	Modifications	Large positive	Large negative	Normal flight range
L. Effect of elevator tab deflection. (Continued)														
Do--	0	0	(f)	25 down	-do-	-do-	-do-	0	14.8	-do-	-do-	65	60	-1
Do--	0	0	(e)	25 up	-do-	-do-	-do-	0	11.7	-do-	-do-	64	60	-1
Do--	0	0	(e)	25 down	-do-	-do-	-do-	0	11.7	-do-	-do-	58	52	-10
Do--	10 up	0	(e)	25 up	-do-	Large	down	45 down	11.7	-do-	$\frac{3}{8}$ -in. extensions installed(fig. 8)	45	(b)	-6
Do--	10 up	0	(e)	25 down	-do-	-do-	-do-	45 down	11.7	-do-	-do-	(b)	38	-14
Do--	10 up	0	(e)	25 up	-do-	-do-	-do-	45 down	11.7	-do-	-do-	64	(b)	-6
Do--	10 up	0	(e)	25 down	-do-	-do-	-do-	45 down	11.7	-do-	None	(b)	49	-17
Do--	0	20 down	(c)	25 up	-do-	-do-	Up	0	14.8	-do-	$\frac{3}{8}$ -in. extensions installed(fig. 8)	63	(b)	No test
Do--	0	20 down	(c)	25 down	-do-	-do-	-do-	0	14.8	-do-	-do-	(b)	51	-do-
Do--	0	0	(c)	0	-do-	-do-	-do-	0	14.8	-do-	$\frac{5}{8}$ -in. extensions installed fig. 8	(b)	42	-14
Do--	0	0	(c)	10 up	-do-	-do-	-do-	0	14.8	-do-	-do-	57	(b)	-10
M. Effect of aileron deflection.														
Neutral	0	0	(a)	25 up	Large	Small	Up	0	11.7	$\frac{3}{4}$ by 4	None	59	(b)	-1
Do--	$2\frac{1}{2}$ up	0	(a)	25 up	-do-	-do-	-do-	0	11.7	$\frac{3}{4}$ by 4	-do-	60	(b)	0
Do--	5 up	0	(c)	25 up	-do-	-do-	-do-	0	18.0	$\frac{3}{4}$ by 4	-do-	65	(b)	0
Do--	0	0	(c)	25 up	-do-	-do-	-do-	0	18.0	$\frac{3}{4}$ by 4	-do-	65	(b)	0
Do--	10 down	0	(c)	25 up	-do-	-do-	-do-	0	18.0	$\frac{3}{4}$ by 4	-do-	63	(b)	-3
Do--	15 up	0	(c)	25 up	-do-	-do-	-do-	0	11.7	$\frac{3}{4}$ by 4	-do-	62	(b)	3
Do--	10 down	0	(c)	25 up	-do-	-do-	-do-	0	11.7	$\frac{3}{4}$ by 4	-do-	57	(b)	-4
Do--	10 up	0	(c)	25 up	-do-	-do-	-do-	0	8.6	$\frac{3}{4}$ by 4	-do-	52	(b)	-1
Do--	0	0	(c)	25 up	-do-	-do-	-do-	0	8.6	$\frac{3}{4}$ by 4	-do-	37	(b)	-3

<sup>a</sup>Free, from trailing edge 17° down to 60° up

<sup>b</sup>Model did not trim in this angle-of-attack range

<sup>c</sup>Free, from trailing edge 60° down to 60° up

<sup>e</sup>Free, from trailing edge 60° down to 70° up

<sup>f</sup>Free, from trailing edge 70° down to 70° up

NATIONAL ADVISORY  
COMMITTEE FOR AERONAUTICS



TABLE II - Continued.  
LONGITUDINAL-TRIM CHARACTERISTICS OF THE XP-55 MODEL.

Model configuration												Trim angle of attack (deg)		
Rudders	Aileron deflection (deg)	Wing-tip trimmer deflection (deg)	Elevator deflection (deg)	Elevator tab deflection (deg)	Elevator size	Wing tip size	Landing gear	Flap deflection (deg)	Center-of-gravity location (percent M.A.C.)	Cowl fin size (in., model-scale)	Modifications	Large positive	Large negative	Normal flight range
M. Effect of aileron deflection. (Continued)														
Do--	10 down	0	(c)	25 up	-do-	-do-	-do-	0	8.6	$\frac{3}{4}$ by 4	-do-	19	(b)	-4
Do--	10 up	0	(c)	25 up	-do-	-do-	-do-	0	5.5	$\frac{3}{4}$ by 4	-do-	35	(b)	-1
Do--	5 up	0	(c)	25 up	-do-	-do-	-do-	0	5.5	$\frac{3}{4}$ by 4	-do-	35	(b)	-2
Do--	0	0	(c)	25 up	-do-	-do-	-do-	0	5.5	$\frac{3}{4}$ by 4	-do-	25	(b)	-2
Do--	5 down	0	(c)	25 up	-do-	-do-	-do-	0	5.5	$\frac{3}{4}$ by 4	-do-	20	(b)	-3
Do--	10 down	0	(c)	25 up	-do-	-do-	-do-	0	5.5	$\frac{3}{4}$ by 4	-do-	(b)	(b)	-3
Do--	10 up	0	(c)	25 up	-do-	-do-	-do-	0	-0.8	$\frac{3}{4}$ by 4	-do-	21	(b)	-2
Do--	5 up	0	(c)	25 up	-do-	-do-	-do-	0	-0.8	$\frac{3}{4}$ by 4	-do-	19	(b)	-2
Do--	0	0	(c)	25 up	-do-	-do-	-do-	0	-0.8	$\frac{3}{4}$ by 4	-do-	(b)	(b)	-3
Do--	10 down	0	(c)	25 up	-do-	-do-	-do-	0	-0.8	$\frac{3}{4}$ by 4	-do-	(b)	(b)	-4
Do--	10 up	0	(c)	10 up	-do-	Large	Down	45 down	14.8	None	(d) $\frac{5}{8}$ -in. extensions installed (Fig 8)	(b)	(b)	-7 -10
Do--	0	0	(c)	10 up	-do-	-do-	-do-	45 down	14.8	-do-	-do-	(b)	27	-10 -13
Full left	(g)	0	(c)	0	-do-	-do-	Up	0	11.7	-do-	-do-	(b)	(b)	-5
Do--	0	0	(c)	0	-do-	-do-	-do-	0	11.7	-do-	-do-	(b)	No test	-11
Do--	(h)	0	(c)	0	-do-	-do-	-do-	0	11.7	-do-	-do-	No test	-do-	-5
Do--	(g)	0	60 up	25 down	-do-	-do-	-do-	0	11.7	-do-	-do-	(b)	65	(b)
Do--	0	0	60 up	25 down	-do-	-do-	-do-	0	11.7	-do-	-do-	(b)	56	(b)
Do--	(h)	0	60 up	25 down	-do-	-do-	-do-	0	11.7	-do-	-do-	(b)	54	(b)
Do--	(g)	0	0	0	-do-	-do-	-do-	0	11.7	-do-	-do-	75	70	-5
Do--	0	0	0	0	-do-	-do-	-do-	0	11.7	-do-	-do-	73	74	-4
Do--	(h)	0	0	0	-do-	-do-	-do-	0	11.7	-do-	-do-	77	73	-5
Do--	(g)	0	60 down	25 up	-do-	-do-	-do-	0	11.7	-do-	-do-	62	(b)	-3
Do--	0	0	60 down	25 up	-do-	-do-	-do-	0	11.7	-do-	-do-	60	(b)	-3
Do--	(h)	0	60 down	25 up	-do-	-do-	-do-	0	11.7	-do-	-do-	60	(b)	2

<sup>b</sup>Model did not trim in this angle-of-attack range

<sup>c</sup>Free, from trailing edge 60° down to 60° up

<sup>d</sup>Free, no stops

<sup>g</sup>Right aileron 28° up, left aileron 9° down

<sup>h</sup>Right aileron 9° down, left aileron 28° up

NATIONAL ADVISORY  
COMMITTEE FOR AERONAUTICS

MR No. L5G31

TABLE II - Continued.  
LONGITUDINAL-TRIM CHARACTERISTICS OF THE XP-55 MODEL.

Model configuration												Trim angle of attack (deg)		
Rudders	Aileron deflection (deg)	Wing-tip trimmer deflection (deg)	Elevator deflection (deg)	Elevator tab deflection (deg)	Elevator size	Wing tip size	Landing gear	Flap deflection (deg)	Center-of-gravity location (percent M.A.C.)	Cowl fin size (in., model-scale)	Modifications	Large positive	Large negative	Normal flight range
N. Effect of rudder deflection.														
Neutral	0	0	(c)	25 up	Large	Small	Up	0	11.7	None	None	61	(b)	-3
Full left	0	0	(c)	25 up	-do-	-do-	-do-	0	11.7	-do-	-do-	61	(b)	-4
Neutral	0	0	(c)	0	-do-	Large	-do-	0	14.8	-do-	<sup>5</sup> / <sub>8</sub> -in. extensions installed(fig.8)	(b)	42	-14
Full left	0	0	(c)	0	-do-	-do-	-do-	0	11.7	-do-	-do-	(b)	45	-11
O. Effect of wing-tip-trimmer deflection.														
Neutral	0	0	(d)	0	Small	Large	Up	0	11.7	None	None	58	58	No test
Do--	0	45 up	(d)	0	-do-	-do-	-do-	0	11.7	-do-	-do-	58	55	-do-
Do--	0	0	(d)	0	-do-	-do-	-do-	0	11.7	1 by 4	-do-	(b)	45	-do-
Do--	0	45 up	(d)	0	-do-	-do-	-do-	0	11.7	1 by 4	-do-	(b)	32	-do-
Do--	10 up	45 up	(c)	0	Large	-do-	down	45 down	18.0	<sup>3</sup> / <sub>4</sub> by 4	-do-	64	29	-do-
Do--	10 up	45 down	(c)	0	-do-	-do-	-do-	45 down	18.0	<sup>3</sup> / <sub>4</sub> by 4	-do-	50	45	-do-
Do--	0	0	(e)	25 up	-do-	-do-	Up	0	11.7	None	<sup>3</sup> / <sub>8</sub> -in. extensions installed(fig. 8)	57	(b)	-2
Do--	0	20 up	(c)	25 up	-do-	-do-	-do-	0	11.7	-do-	-do-	56	(b)	2
Do--	0	20 down	(c)	25 up	-do-	-do-	-do-	0	11.7	-do-	-do-	45	(b)	-6
P. Effect of landing gear.														
Neutral	0	0	(e)	25 up	Large	Large	Up	0	11.7	None	None	63	(b)	-2
Do--	0	0	(e)	25 up	-do-	-do-	down	0	11.7	-do-	-do-	64	(b)	-2
Do--	0	0	(e)	25 up	-do-	-do-	Up	0	11.7	-do-	<sup>3</sup> / <sub>8</sub> -in. extensions installed(fig. 8)	57	(b)	-2
Do--	0	0	(e)	25 up	-do-	-do-	down	0	11.7	-do-	-do-	(b)	(b)	-2
Do--	0	0	(c)	10 up	-do-	-do-	Up	0	14.8	-do-	<sup>5</sup> / <sub>8</sub> -in. extensions installed(fig. 8)	57	(b)	-10
Do--	0	0	(c)	10 up	-do-	-do-	down	0	14.8	-do-	-do-	(b)	(b)	-10
														-6

<sup>b</sup>Model did not trim in this angle-of-attack range

<sup>c</sup>Free, from trailing edge 60° down to 60° up

<sup>d</sup>Free, no stops

<sup>e</sup>Free, from trailing edge 60° down to 70° up

NATIONAL ADVISORY  
COMMITTEE FOR AERONAUTICS

TABLE II.- Continued.  
LONGITUDINAL-TRIM CHARACTERISTICS OF THE XP-55 MODEL.

Model configuration												Trim angle of attack (deg)		
Rudders	Aileron deflection (deg)	Wing-tip Trimmer deflection (deg)	Elevator deflection (deg)	Elevator tab deflection (deg)	Elevator size	Wing tip size	Landing gear	Flap deflection (deg)	Center-of-gravity location (percent M.A.C.)	Cowl fin size (in., model-scale)	Modifications	Large positive	Large negative	Normal flight range
Q. Effect of flaps.														
Neutral	0	0	(e)	25 up	Large	Large	Down	0	11.7	None	None	64	(b)	-2
Do--	10 up	0	(e)	25 up	-do-	-do-	-do-	45 down	11.7	-do-	-do-	64	(b)	-6
Do--	0	0	(c)	10 up	-do-	-do-	-do-	0	14.8	-do-	<sup>5</sup> / <sub>8</sub> -in. extensions installed (Fig.8)	(b)	(b)	-10
Do--	0	0	(c)	10 up	-do-	-do-	-do-	45 down	14.8	-do-	-do-	(b)	27	-6
Do--	10 up	0	(c)	10 up	-do-	-do-	-do-	45 down	14.8	-do-	-do-	(b)	(b)	-13
														-10
														-7
R. Effect of the landing condition (Flaps 45° down and landing gear extended).														
Neutral	10 up	0	(c)	0	Large	Small	Down	45 down	11.7	<sup>3</sup> / <sub>4</sub> by 4	None	52	28	(b)
Do--	0	0	(c)	0	-do-	-do-	Up	0	11.7	<sup>3</sup> / <sub>4</sub> by 4	-do-	50	30	(b)
Do--	10 up	0	(c)	0	-do-	-do-	Down	45 down	11.7	<sup>3</sup> / <sub>4</sub> by 4	-do-	(b)	32	No test
Do--	0	0	(c)	25 up	-do-	-do-	Up	0	11.7	<sup>3</sup> / <sub>4</sub> by 4	-do-	57	(b)	-do-
Do--	10 up	0	(e)	25 down	-do-	Large	Down	45 down	11.7	None	-do-	(b)	49	-17
Do--	0	0	(e)	25 down	-do-	-do-	Up	0	11.7	-do-	-do-	(b)	54	-14
Do--	10 up	0	(c)	0	-do-	Small	Down	45 down	18.0	<sup>3</sup> / <sub>4</sub> by 4	-do-	60	39	No test
Do--	0	0	(c)	25 up	-do-	-do-	Up	0	18.0	<sup>3</sup> / <sub>4</sub> by 4	-do-	65	(b)	No test
Do--	10 up	0	(e)	25 down	-do-	Large	-do-	45 down	11.7	None	-do-	(b)	49	-17
Do--	0	0	(e)	25 down	-do-	-do-	Up	0	11.7	-do-	-do-	(b)	54	-14
Do--	10 up	0	(e)	25 up	-do-	-do-	Down	45 down	11.7	-do-	-do-	64	(b)	-6
Do--	0	0	(e)	25 up	-do-	-do-	Up	0	11.7	-do-	<sup>3</sup> / <sub>8</sub> -in. extensions installed (Fig.8)	57	(b)	-7
Do--	10 up	0	(e)	25 up	-do-	-do-	Down	45 down	11.7	-do-	-do-	45	(b)	-6

<sup>b</sup>Model did not trim in this angle-of-attack range

<sup>c</sup>Free, from trailing edge 60° down to 60° up

<sup>e</sup>Free, from trailing edge 60° down to 70° up

NATIONAL ADVISORY  
COMMITTEE FOR AERONAUTICS

TABLE II.- Concluded.  
LONGITUDINAL-TRIM CHARACTERISTICS OF THE XP-55 MODEL.

Model configuration												Trim angle of attack (deg)		
Rudders	Aileron deflection (deg)	Wing-tip trimmer deflection (deg)	Elevator deflection (deg)	Elevator tab deflection (deg)	Elevator size	Wing tip size	Landing gear	Flap deflection (deg)	Center-of gravity location (percent M.A.C.)	Cowl fin size (in., model-scale)	Modifications	Large positive	Large negative	Normal flight range
R. Effect of the landing condition (Flaps 45° down and landing gear extended). (Continued)														
Do--	10 up	0	(e)	25 down	-do-	-do-	-do-	45 down	11.7	-do-	-do-	(b)	38	-14
Do--	0	0	(c)	25 up	-do-	-do-	Up	0	11.7	None	5/8 -in. extensions installed (Fig. 8)	(b)	(b)	-3
Do--	10 up	0	(c)	25 up	-do-	-do-	Down	45 down	11.7	-do-		-do-	(b)	(b)
Neutral	0	0	(c)	10 up	Large	Large	Up	0	14.8	None	-do-	57	(b)	-1 -10
Do--	10 up	0	(c)	10 up	-do-	-do-	Down	45 down	14.8	-do-	-do-	(b)	(b)	-10 -7
S. Final configuration.														
Full left	(g)	0	(c)	0	Large	Large	Up	0	11.7	None	5/8 -in. extensions installed (Fig. 8)	(b)	(b)	-5
Do--	(g)	0	60 up	25 down	-do-	-do-	-do-	0	11.7	-do-		-do-	(b)	65
Do--	(g)	0	0	0	-do-	-do-	-do-	0	11.7	-do-	-do-	75	70	-5
Do--	(g)	0	60 down	25 up	-do-	-do-	-do-	0	11.7	-do-	-do-	62	(b)	-3
Do--	0	0	-do-	25 up	-do-	-do-	-do-	0	11.7	-do-	-do-	60	(b)	-3
Do--	0	0	0	0	-do-	-do-	-do-	0	11.7	-do-	-do-	73	74	-4
Do--	0	0	60 up	25 down	-do-	-do-	-do-	0	11.7	-do-	-do-	(b)	56	(b)
Do--	0	0	(c)	0	-do-	-do-	-do-	0	11.7	-do-	-do-	(b)	No test	-11
Do--	(h)	0	(c)	0	-do-	-do-	-do-	0	11.7	-do-	-do-	No test	-do-	-5
Do--	(h)	0	60 up	25 down	-do-	-do-	-do-	0	11.7	-do-	-do-	(b)	54	(b)
Do--	(h)	0	0	0	-do-	-do-	-do-	0	11.7	-do-	-do-	77	73	-5
Do--	(h)	0	60 down	25 up	-do-	-do-	-do-	0	11.7	-do-	-do-	60	(b)	2

<sup>b</sup>Model did not trim in this angle-of-attack range

<sup>c</sup>Free, from trailing edge 60° down to 60° up

<sup>e</sup>Free, from trailing edge 60° down to 70° up

<sup>g</sup>Right aileron 28° up, left aileron 9° down

<sup>h</sup>Right aileron 9° down, left aileron 28° up

NATIONAL ADVISORY  
COMMITTEE FOR AERONAUTICS

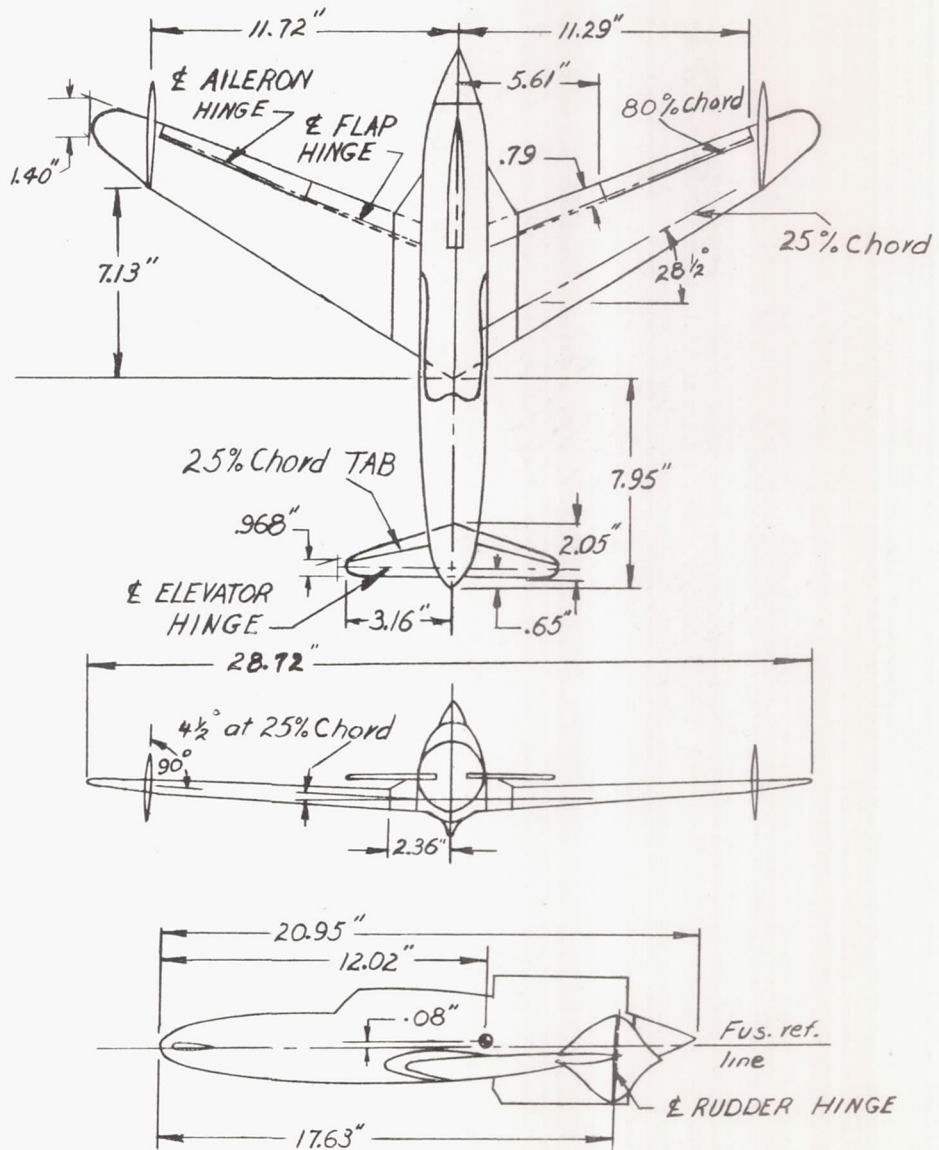
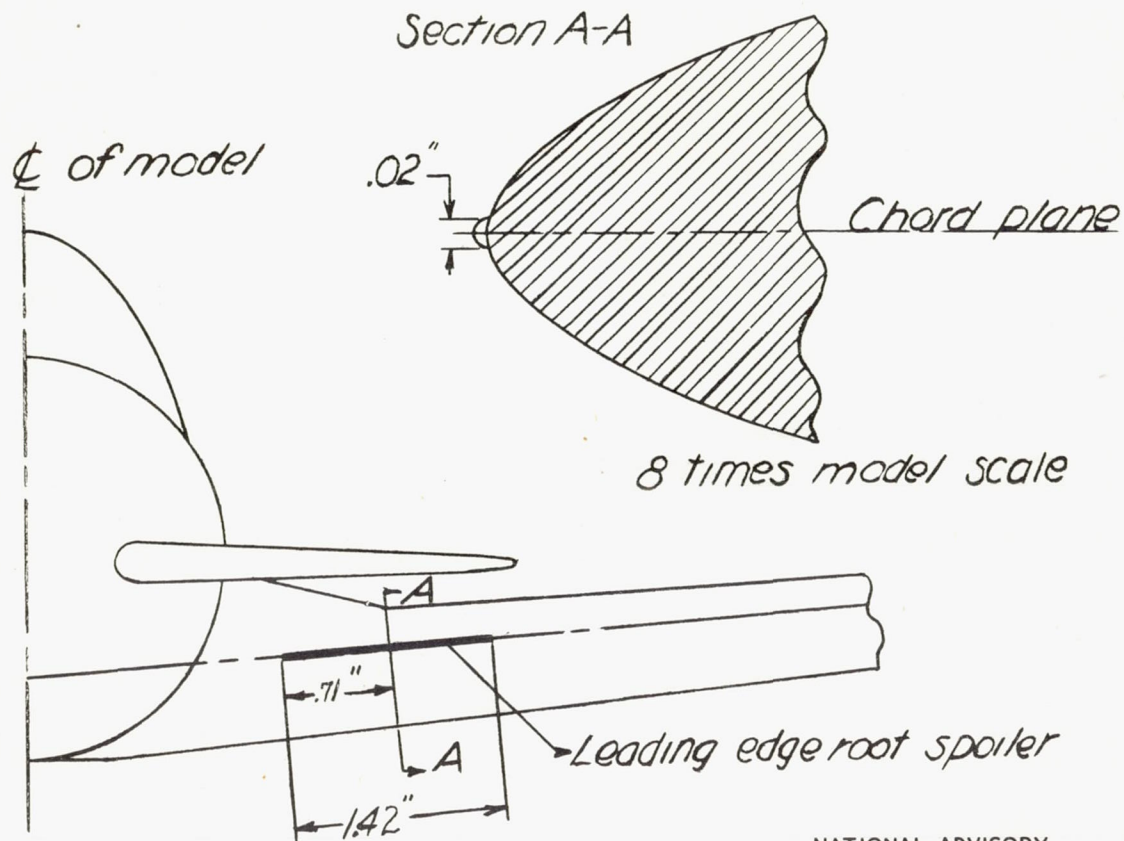

Figure 1.- The 0.059-scale model of the Curtiss-Wright XP-55 airplane tested in the 15-foot free-spinning tunnel. Wing root chord incidence,  $4.25^\circ$ , leading edge up. Tip chord incidence,  $0.75^\circ$ , leading edge up. Center-of-gravity location shown is for the normal loading with the landing gear retracted.



NATIONAL ADVISORY  
COMMITTEE FOR AERONAUTICS

Figure 2. - Leading-edge root spoilers tested on the 0.059-scale model of the XP-55 airplane. Dimensions are model scale.

L-538

MR No. L5G31

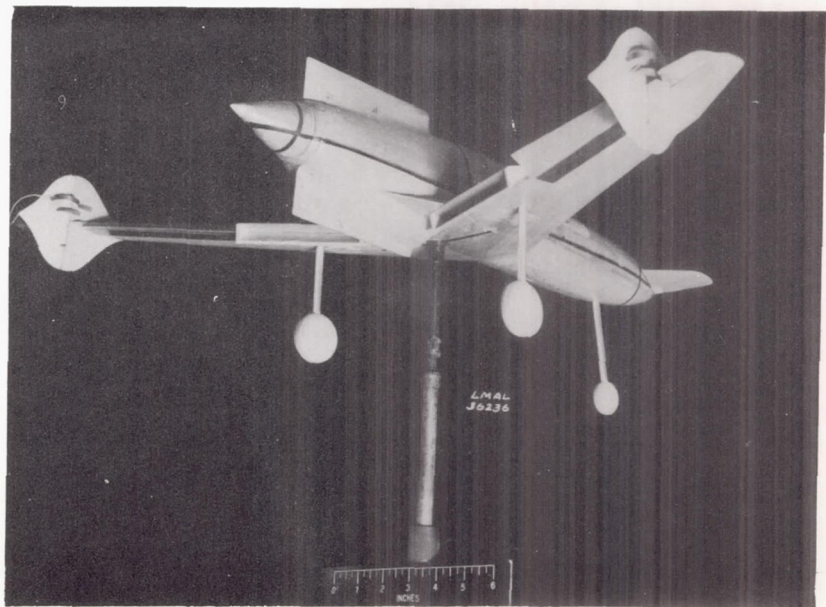
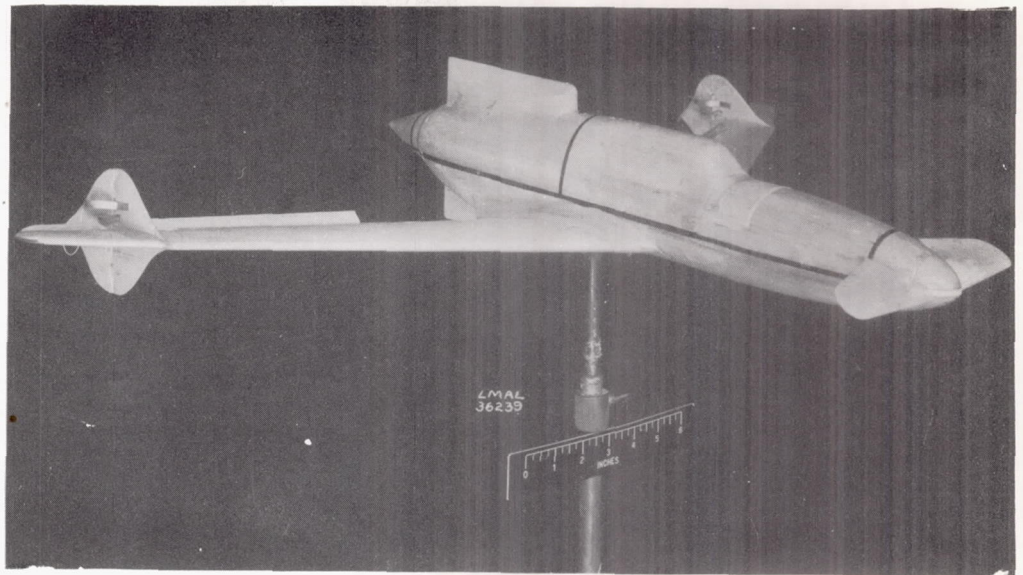

Figure 3.- The 0.059-scale model of the Curtiss-Wright XP-55 airplane in the clean and landing conditions.

NATIONAL ADVISORY COMMITTEE FOR AERONAUTICS  
LANGLEY MEMORIAL AERONAUTICAL LABORATORY - LANGLEY FIELD, VA.

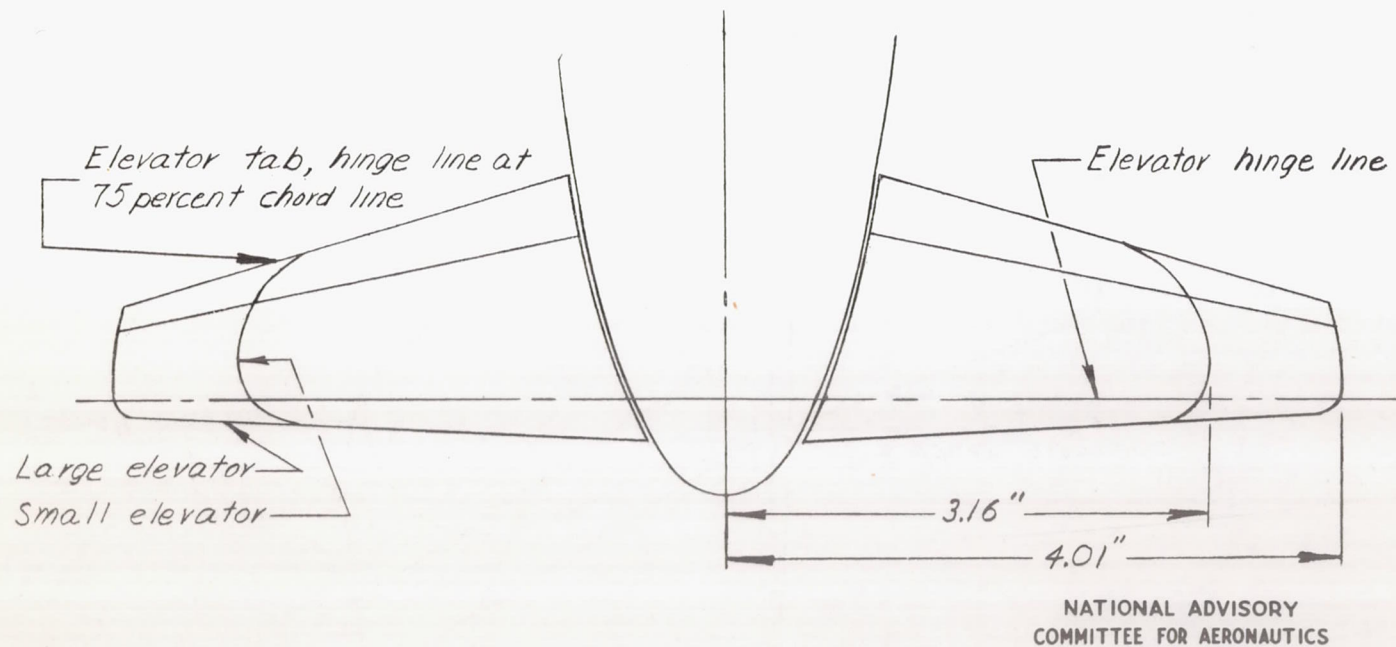

Figure 4.- Large and small elevators tested on the 0.059-scale model of the XP-55 airplane. Dimensions are model scale.



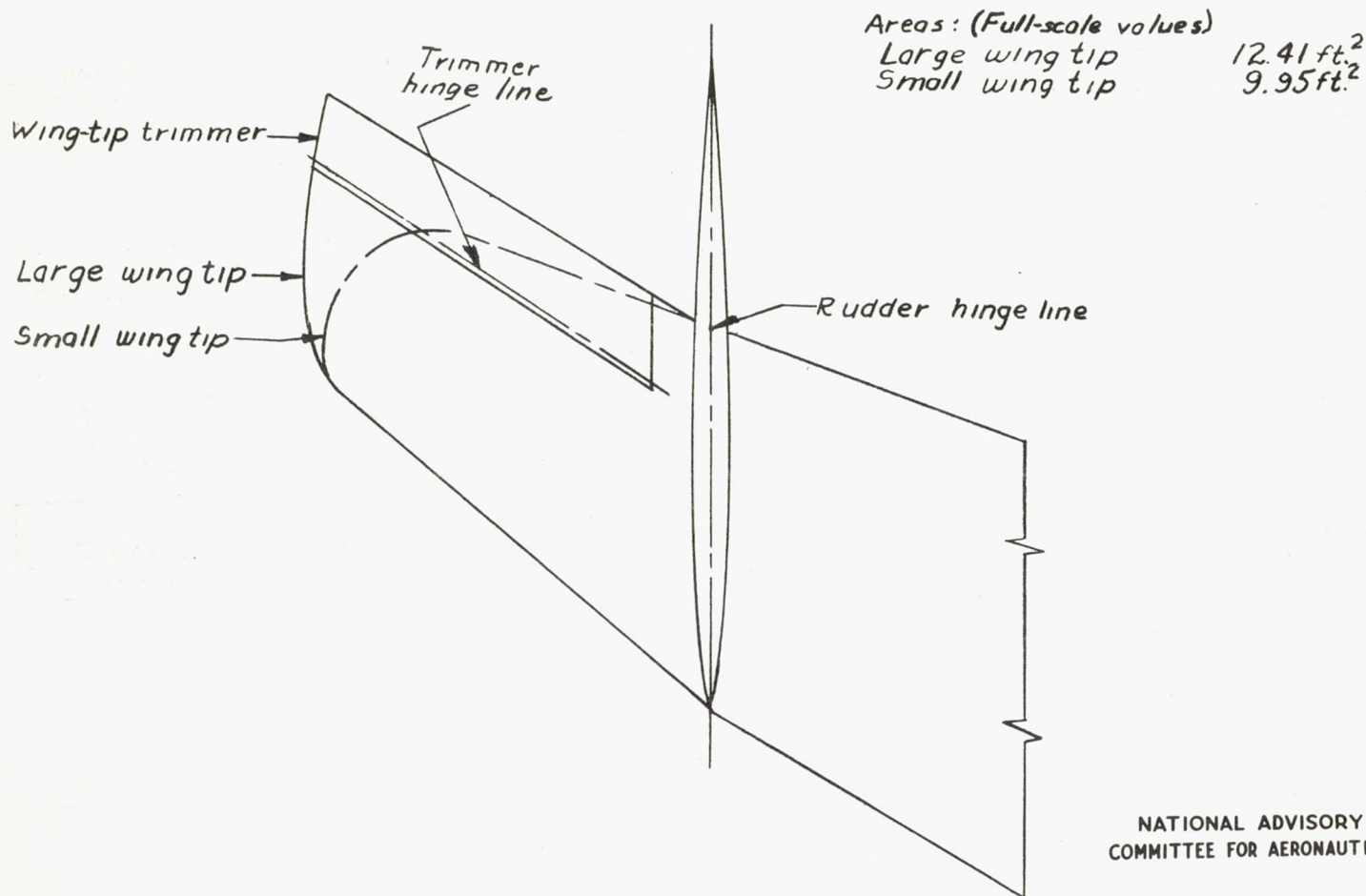

Figure 5.- Large and small wing tips tested on the 0.059-scale model of the XP-55 airplane.

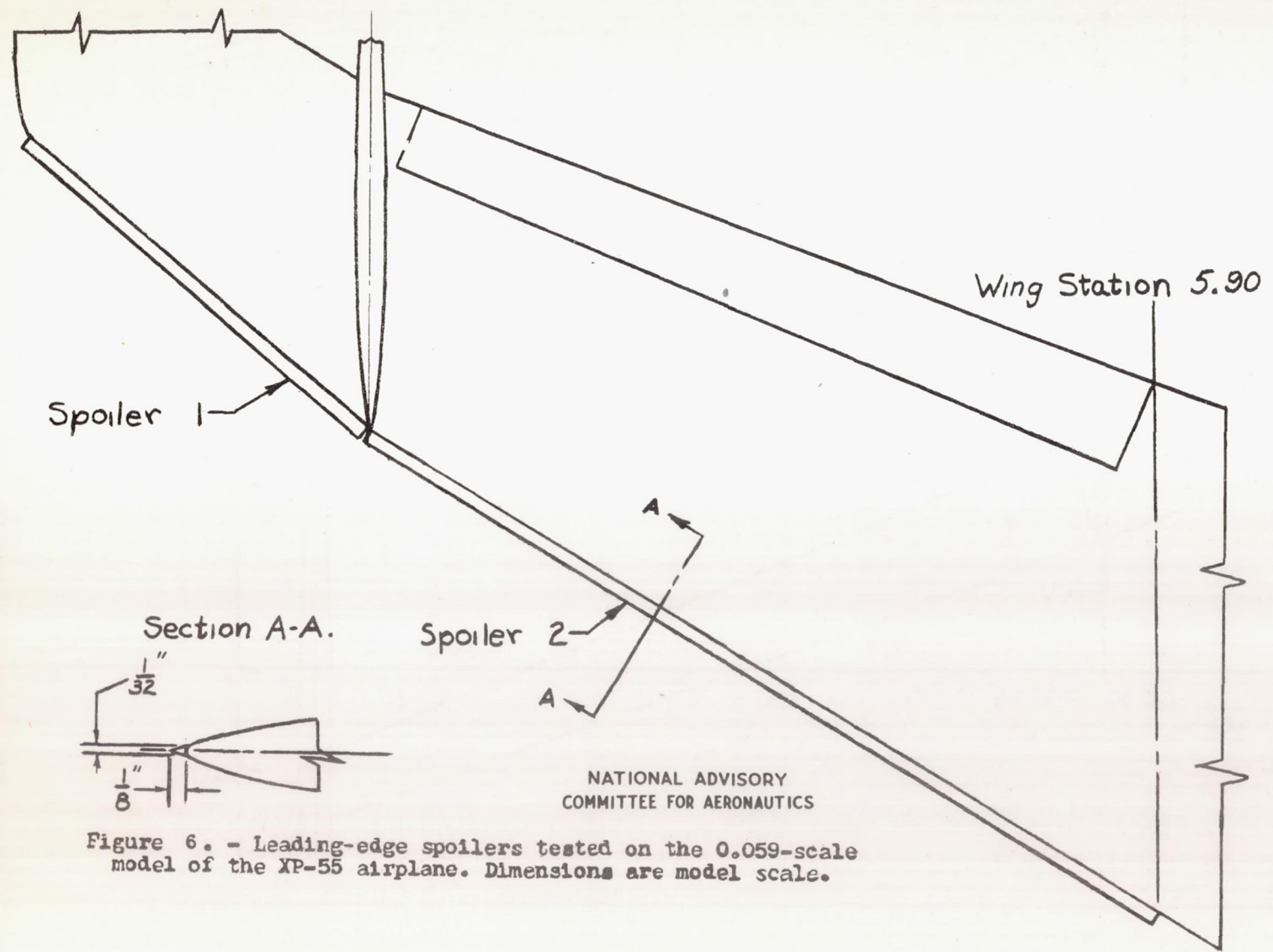

Figure 6. - Leading-edge spoilers tested on the 0.059-scale model of the XP-55 airplane. Dimensions are model scale.

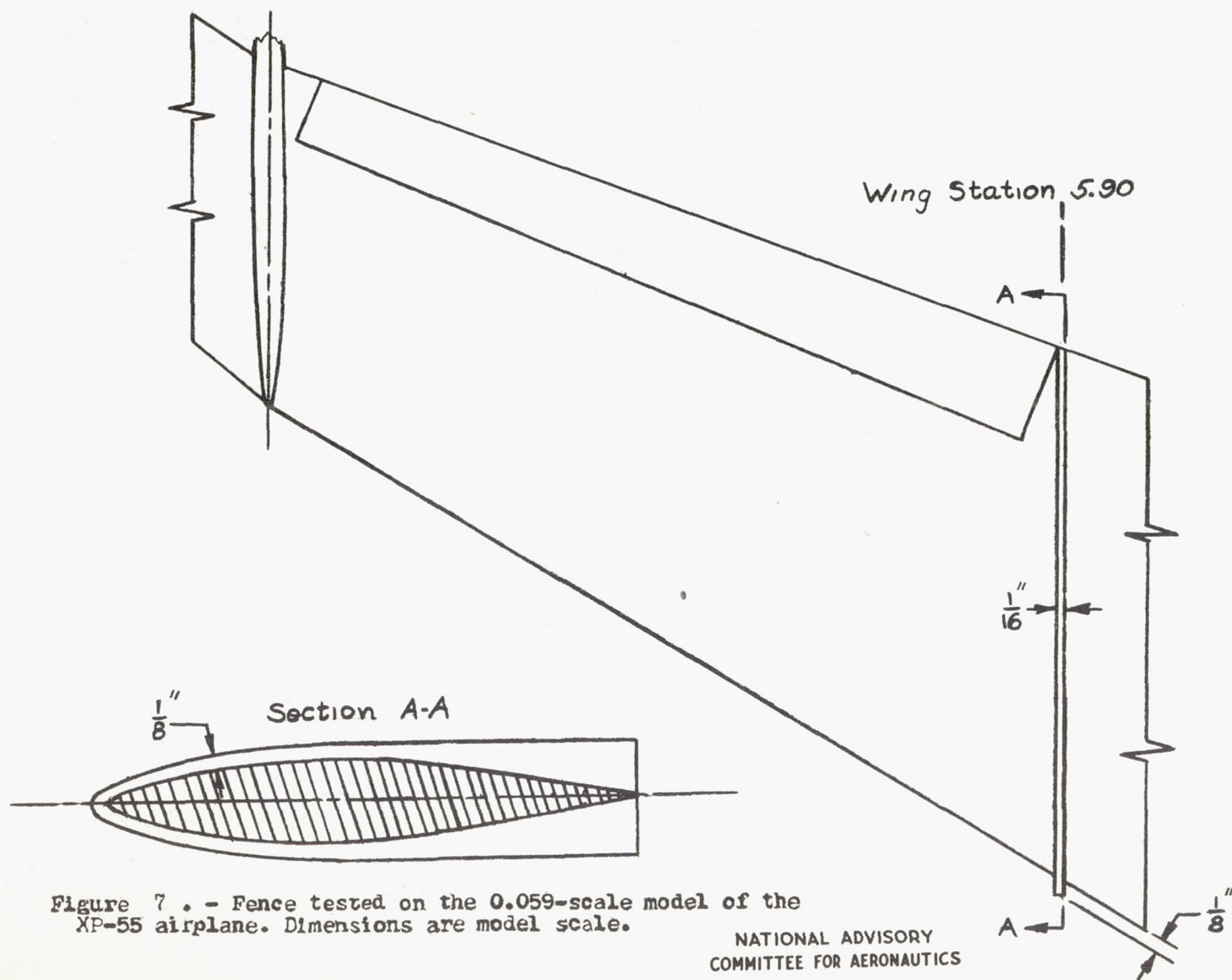

Figure 7 . - Fence tested on the 0.059-scale model of the XP-55 airplane. Dimensions are model scale.

NATIONAL ADVISORY  
COMMITTEE FOR AERONAUTICS

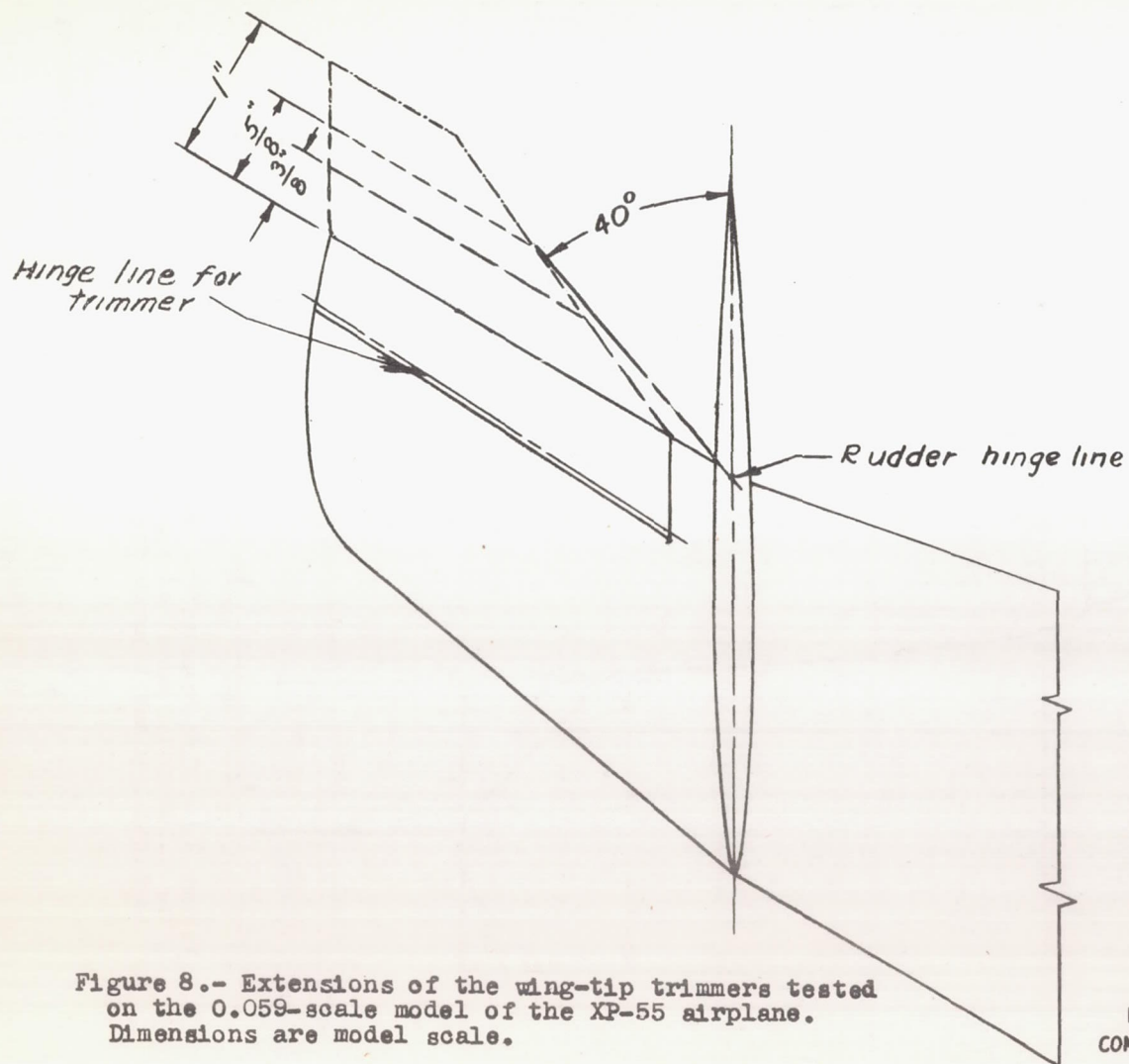

Figure 8.- Extensions of the wing-tip trimmers tested on the 0.059-scale model of the XP-55 airplane. Dimensions are model scale.

NATIONAL ADVISORY  
COMMITTEE FOR AERONAUTICS

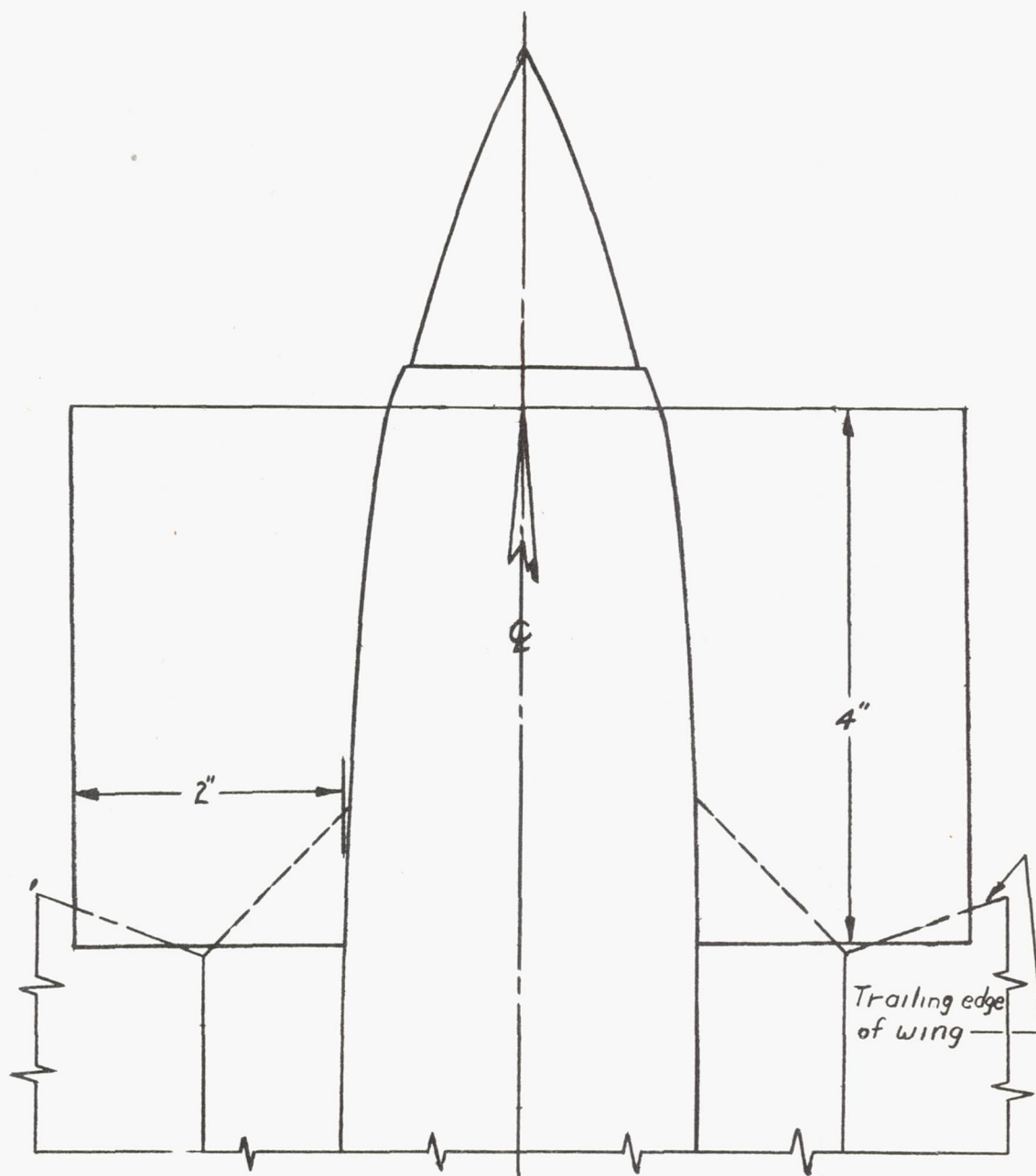

Figure 9. - Plan view of the 2-inch by 4-inch cowl fins tested on the 0.059-scale model of the XP-55 airplane. Cowl fins are in horizontal plane through thrust line. Dimensions are model scale.

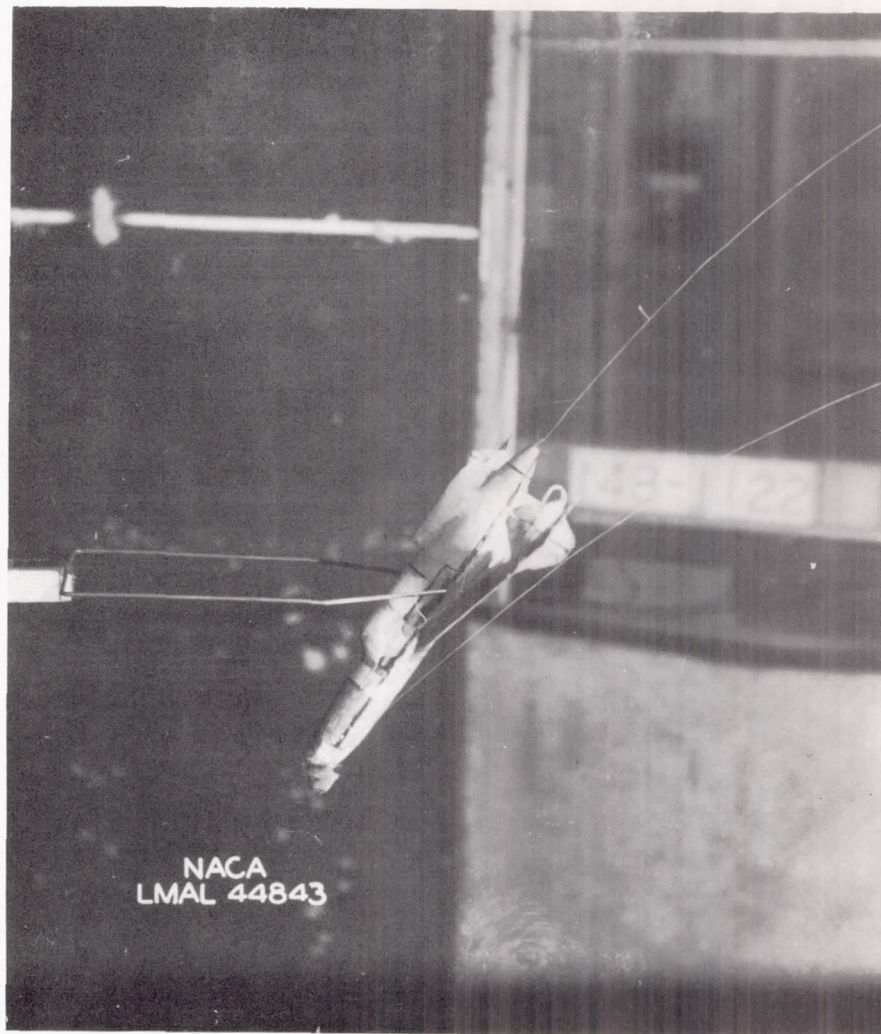
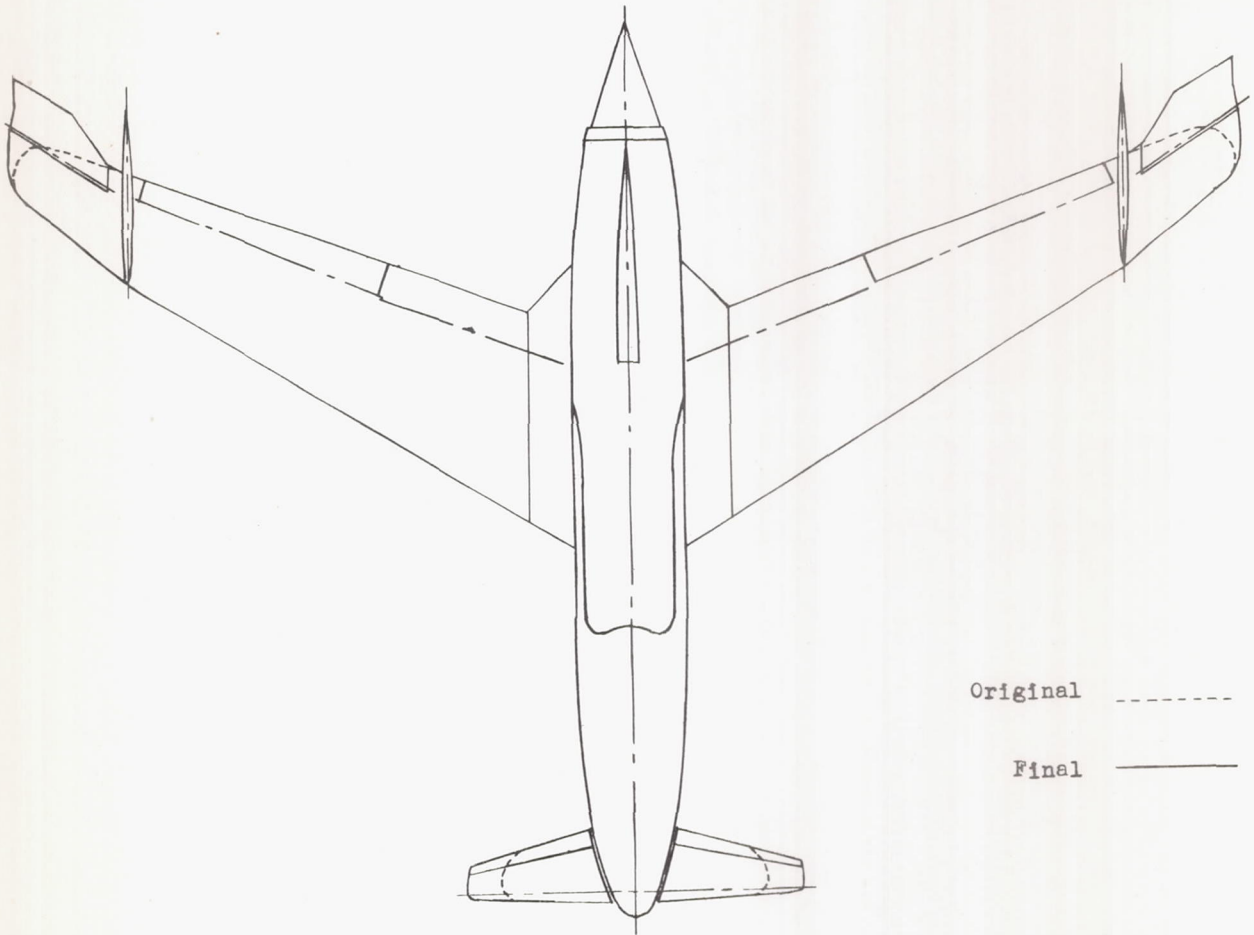

Figure 10.- The 0.059-scale model of the XP-55 airplane as mounted on the longitudinal-trim rig.

L-538



Original -----  
Final -----

Figure 11.- Comparison of original and final configurations of the 0.059-scale model of the XP-55 airplane.