

ACR No. L4L21a

NATIONAL ADVISORY COMMITTEE FOR AERONAUTICS

WARTIME REPORT

ORIGINALLY ISSUED
January 1945 as
Advance Confidential Report L4L21a

EFFECTS OF COMPRESSIBILITY ON MAXIMUM LIFT COEFFICIENTS

FOR SIX PROPELLER AIRFOILS

By Harold E. Cleary

Langley Memorial Aeronautical Laboratory
Langley Field, Va.

NACA

Superseded ACR L4L21a
Superseded CR Oct 44 WASHINGTON

NACA WARTIME REPORTS are reprints of papers originally issued to provide rapid distribution of advance research results to an authorized group requiring them for the war effort. They were previously held under a security status but are now unclassified. Some of these reports were not technically edited. All have been reproduced without change in order to expedite general distribution.

NATIONAL ADVISORY COMMITTEE FOR AERONAUTICS

ADVANCE CONFIDENTIAL REPORT

EFFECTS OF COMPRESSIBILITY ON MAXIMUM LIFT COEFFICIENTS
FOR SIX PROPELLER AIRFOILS

By Harold E. Cleary

SUMMARY

An extension of previously reported data on the variation of maximum lift coefficient with Mach number, camber, and thickness ratio is presented. The data were obtained from pressure-distribution tests in the Langley 8-foot high-speed tunnel of six propeller airfoils of 1-foot chord.

It was found that the maximum lift coefficients of all the airfoils were markedly affected by compressibility at Mach numbers as low as 0.2. At Mach numbers above the order of 0.45, large increases in maximum lift coefficient occurred. The combination of a thickness ratio of 0.15 and a design lift coefficient of 0.7 was found to be critical, with adverse effects on maximum lift coefficient occurring over most of the speed range investigated.

INTRODUCTION

It has been pointed out in reference 1 that the prediction of high-lift performance of airfoils at high speeds based on low-speed data can be seriously in error. The low critical speeds occurring at high lifts and the separation produced by severe pressure gradients over the airfoil affect the maximum lift coefficient at Mach numbers as low as 0.2. It was also indicated that large increases in the maximum lift coefficient are to be expected at values of Mach number above 0.5. The data presented herein include an extension to higher Mach numbers of the data for the three airfoils presented in reference 1 as well as data for three additional airfoils tested to establish more definitely the effects of camber and thickness ratio.

The effects of compressibility on maximum lift coefficient as presented in reference 1 and herein have particular application to propeller performance at take-off and some climb conditions. These applications combine high-lift loadings on the blades with high speeds over a considerable portion of the blades.

The tests were conducted in the Langley 8-foot high-speed tunnel on models of 1-foot chord to obtain full-scale propeller Reynolds numbers and reduced tunnel-wall effects. Measurements consisted, principally, of the pressure distribution at the center of the airfoil model. This method of measurement gives effectively two-dimensional results, which best illustrate the type of phenomenon that occurs.

SYMBOLS

V	air-stream velocity, feet per second
a	speed of sound in air, feet per second
M	air-stream Mach number (V/a)
R	Reynolds number
l	section lift, pounds per foot of span
c	model chord, feet
ρ	air-stream mass density, slugs per cubic foot
q	air-stream dynamic pressure, pounds per square foot $\left(\frac{1}{2}\rho V^2\right)$
c_l	section lift coefficient (l/qc)
$c_{l_{max}}$	maximum section lift coefficient
t	model maximum thickness, feet
p	local static pressure, pounds per square foot

p_0 air-stream static pressure, pounds per square foot

C_p pressure coefficient $\left(\frac{p - p_0}{q} \right)$

APPARATUS AND METHODS

The Langley 8-foot high-speed tunnel is a single-return, circular-section, closed-throat tunnel. The airspeed is continuously controllable from about 75 to 550 miles per hour. The turbulence of the air stream, as indicated by transition measurements on airfoils, is unusually low but somewhat higher than that of free air.

Six models having NACA 16-209, 16-509, 16-709, 16-215, 16-515, and 16-715 airfoil sections of 1-foot chord were investigated. Thirty pressure orifices distributed along the chord were located at essentially the same spanwise station at the center of the air stream. The chordwise orifice locations and airfoil shapes are shown in figure 1. The airfoil ordinates were calculated by the methods described in reference 2.

The model, when mounted in the tunnel, completely spanned the jet (fig. 2). Except for auxiliary streamline-wire bracing, required by structural considerations, the standard mounting and setup for the Langley 8-foot high-speed tunnel were employed. Tests at low and medium speeds with and without braces indicated that interference of the auxiliary supports on the flow at the measurement station was negligible.

The surface pressure orifices in the airfoil were connected to a multiple-tube manometer located outside the test section. The pressure tubing connecting the orifices had a small diameter and was located within the airfoil. The pressures at all orifices were recorded simultaneously by photographing the multiple-tube manometer.

The Mach number range extended from 0.12 to 0.68 and the Reynolds number range, from 0.87×10^6 to 3.75×10^6 . The variation of Reynolds number with Mach number is shown in figure 3.

RESULTS

The maximum section lift coefficient $c_{l_{max}}$ was determined as the highest value of lift coefficient in the positive range of angle of attack. The values of normal-force coefficient were obtained from integration of the chordwise pressure distribution. Analysis has shown that, up to the value of maximum lift coefficient, the normal-force coefficient and the lift coefficient are essentially the same.

The angles of attack at which the maximum lift coefficient occurred for the various airfoils are presented in table I. The variation of maximum section lift coefficient with Mach number is given in figure 4. The small arrowheads on the curves between Mach numbers of 0.40 and 0.50 indicate the points beyond which the critical speed has been exceeded. Figure 5 shows the pressure distribution over the NACA 16-215 airfoil for Mach numbers of 0.25 and 0.40 at an angle of attack of 13° , which is the stall angle at $M = 0.25$. Pressure distributions over the NACA 16-515 airfoil are presented in figure 6 for Mach numbers of 0.40, 0.55, and 0.60 at an angle of attack of 11° . Pressure distributions over the NACA 16-715 airfoil are given in figure 7 for Mach numbers of 0.33, 0.60, and 0.67 at an angle of attack of 10° . These angles of attack, 11° and 10° , are near the angle of stall and represent the phenomena that occur in the neighborhood of maximum lift. The lower-surface pressure distributions are presented only for the lowest values of Mach number in figures 6 and 7 because little change takes place over the lower surface in the range of Mach number shown.

These data, as presented, have not been corrected for wind-tunnel-wall interference. An analysis, however, has been made of these effects according to the methods of reference 3 which gave the following maximum corrections:

	Mach number	Lift	Moment coefficient	Drag coefficient	Angle of attack
Design lift range	Less than 1 percent	Less than -1 percent	-0.002	Less than 0.0001	Less than $\pm 0.01^\circ$
High lift range	1 percent	-2 percent	-0.002	0.001	$\pm 0.05^\circ$

The method of correction used has only qualitative application at high values of lift coefficient and super-critical values of Mach number. The corrections obtained, however, give a good estimate of the order of the interference effects.

DISCUSSION

It has been shown in references 1 and 4 that the maximum lift coefficient may be adversely affected at a Mach number as low as 0.20. Reference 1 shows that, when Mach number and Reynolds number were changed simultaneously, the maximum lift coefficient increased until a Mach number of 0.20 was reached. Further increase in Mach number led to adverse compressibility effects and separation phenomena. This effect, as has been shown in reference 1, prevented further rise in $c_{l_{max}}$ in the

case of a thin airfoil and caused a pronounced reduction in $c_{l_{max}}$ in the case of a relatively thick airfoil.

It is further indicated in reference 1 that increases in Mach number above 0.50 will lead to marked increases in airfoil maximum lift coefficients.

The data presented herein, which include an extension of the ranges of camber, thickness, and Mach number of reference 1, substantiate and extend the conclusions of reference 1.

The angles of attack for maximum lift (table I) are higher for the thicker airfoils than for the thinner airfoils and, in general, increase with camber for the thicker airfoils throughout the range of Mach number. For a given camber and thickness, the angle for maximum lift tends to decrease with increasing Mach number.

The results presented in figure 4 show that the maximum section lift coefficient is a function of Mach number, thickness ratio, and camber. The variation of the maximum lift coefficient with Mach number for a given camber and thickness generally shows an increase to a Mach number of 0.25. Between Mach numbers of 0.25 and 0.50 virtually no further increase in the maximum lift coefficient is found for the thinner airfoils and a large decrease is found for the 15-percent-thick airfoils. This general variation is not followed by the NACA 16-209 airfoil. The nearly constant value of the maximum lift coefficient up to a Mach number of 0.50 for this airfoil is in accord with previous results, which indicated that thin airfoils, because they have small leading-edge radii, have effectively fixed degrees of separation and separation points. Beyond a Mach number of approximately 0.50 the maximum lift coefficient increases sharply for all the airfoils and decreases again only for the NACA 16-715 airfoil beyond a Mach number of 0.60.

The general effect of increasing either thickness or camber is to increase the value of the maximum lift coefficient. The effect of increasing thickness on the variation of $c_{l_{max}}$ with Mach number is to accentuate the adverse effects in the region between Mach numbers of 0.25 and 0.50.

The increase of maximum lift coefficient with Mach number observed at low speeds up to a Mach number of 0.25 is similar to the variation with Reynolds number for airfoils of medium thickness. Further increase in speed above a Mach number of 0.25 leads to larger adverse pressure gradients that induce greater thickening of the boundary layer or separation, which reduce the circulation around the airfoil. This effect is illustrated by the pressure distribution over the NACA 16-215 airfoil (fig. 5) at an angle of attack of 13° , which is the angle of stall at a Mach number of 0.25 and is beyond the angle of stall at a Mach number of 0.40. The pressures near the trailing edge indicate the increase in separation between Mach numbers of 0.25 and 0.40, and the pressures over the rest of the airfoil show the loss of lift accompanying these changes.

The large increases in maximum lift coefficient beyond a Mach number of 0.50 (fig. 4) are due to the rearward movement of the peak pressures over the airfoil after the critical speed of the section has been reached and strong compression shock has been established. (The critical Mach number at maximum lift is 0.45 or below for all these airfoils except the NACA 16-209 airfoil, for which the critical Mach number is 0.50.) The effect of these phenomena is illustrated in figures 6 and 7, which show the increase in area under the pressure-distribution curve that accompanies supercritical compressibility effects as the Mach number is increased.

The failure of the NACA 16-715 airfoil to develop a maximum lift coefficient much greater than that for the NACA 16-515 airfoil in the Mach number range from 0.12 to 0.25 (fig. 4) is ascribed to a critical combination of camber and thickness which leads to extreme adverse pressure-recovery gradients over the rear portion of the airfoil. These adverse pressure gradients result in separation at lower lift coefficients than might be expected for an airfoil of this camber. The angles of attack for maximum lift (table I) indicate that for an increase of camber from 0.5 to 0.7 for airfoils having a thickness ratio of 0.15, there is no increase in angle of attack at Mach numbers less than 0.33. Between Mach numbers of 0.33 and 0.48, the angle of maximum lift for the NACA 16-715 airfoil is higher than that for the NACA 16-515 airfoil and thus indicates an improvement of the flow. This improvement is illustrated in figure 4 in the Mach number region of 0.35, where the increment of maximum section lift coefficient between the NACA 16-515 and 16-715 airfoils is of the same order as that between the NACA 16-509 and 16-709 airfoils. The critical nature of the NACA 16-715 airfoils is further indicated by the loss of maximum section lift coefficient that occurs beyond a Mach number of 0.60. This loss is principally a separation phenomenon and is illustrated by the pressure distribution at a Mach number of 0.67 shown in figure 7.

The increase of maximum lift coefficient with camber results from the fact that at an angle of attack of 0° the airfoils having higher camber develop higher lift coefficients, have essentially the same lift-curve slope, and (as illustrated in table I) stall at about the same angle of attack. The effect on airfoil characteristics of increasing thickness is to increase the value of the

stall angle. A further effect of thickness is to change the type of flow over the leading edge, as pointed out in reference 5.

It was pointed out in reference 4 that some improvement in propeller take-off thrust may be effected in marginal designs through utilization of the increase in maximum lift obtained from increased design camber. Because it has been indicated that small changes in camber have little effect on the critical speeds of these sections when operating in the design range, small increases in camber will not materially affect the high-speed operation.

The large increases in maximum section lift coefficient in the high Mach number range above 0.50 may be utilized for increased take-off thrust because a large portion of the propeller blade operates at relatively high values of Mach number even at low forward speeds. Eventual losses are to be expected, however, at Mach numbers higher than the range of the present tests, as indicated by the results for the NACA 16-715 airfoil.

These results for the NACA 16-715 airfoil are significant when contrasted with the results for the NACA 16-709 and 16-215 airfoils throughout the range of Mach number tested. The results indicate that the combination of a thickness ratio of 0.15 and a design c_l of 0.7 is unconservative, and special care must be taken in the selection of sections in or beyond this critical range of combinations of thickness ratio and design lift coefficient.

The results of those tests are believed to be common, at least qualitatively, to all airfoils in current use because in the stall region all airfoils exhibit a characteristic pressure peak near the leading edge and, hence, have qualitatively the same type of flow pattern.

CONCLUSIONS

The pressure-distribution measurements of six NACA 16-series airfoils made to investigate the effects of compressibility on the maximum section lift coefficients indicated that:

1. The maximum lift coefficient of airfoils was affected by compressibility at Mach numbers as low as 0.20.

2. At high Mach numbers large increases in the maximum lift coefficient occurred.

3. Increase in camber resulted in increases in the maximum lift coefficient.

4. Increase in thickness caused an increase in the maximum lift coefficient and accentuated the compressibility effects.

5. The combination of a thickness ratio of 0.15 and a design lift coefficient of 0.7 resulted in an unconservative section with losses in maximum lift coefficient at high Mach numbers. Special care must be exercised in the selection of sections in this critical range of combinations of thickness ratio and design lift coefficient.

6. For propeller designs that are marginal in take-off, improvement in take-off thrust may be realized by increase in design camber.

Langley Memorial Aeronautical Laboratory
National Advisory Committee for Aeronautics
Langley Field, Va.

REFERENCES

1. Stack, John, Fedziuk, Henry A., and Cleary, Harold E.: Preliminary Investigation of the Effect of Compressibility on the Maximum Lift Coefficient. NACA ACR, Feb. 1943.
2. Stack, John: Tests of Airfoils Designed to Delay the Compressibility Burble. NACA TN No. 976, Dec. 1944. (Reprint of NACA ACR, June 1939.)
3. Vincenti, Walter G., and Graham, Donald J.: The Effect of Wall Interference upon the Aerodynamic Characteristics of an Airfoil Spanning a Closed-Throat Circular Wind Tunnel. NACA ACR No. 5D21, 1945.
4. Stack, John: Compressibility Effects in Aeronautical Engineering. NACA ACR, Aug. 1941.
5. Cleary, Harold E.: Variation of Peak Pitching-Moment Coefficients for Six Airfoils as Affected by Compressibility. NACA ACR No. 14E17, 1944.

TABLE I
 ANGLES OF ATTACK FOR MAXIMUM LIFT COEFFICIENT

NACA airfoil section Mach number	Angle of attack (deg)					
	16-209	16-509	16-709	16-215	16-515	16-715
0.12	10.0	10.0	11.0	12.0	15.0	15.0
.20	10.0	9.5	10.5	12.5	15.5	15.0
.25	9.0	8.5	10.0	13.0	15.0	15.0
.33	10.0	9.0	9.5	12.0	14.0	15.0
.40	10.0	8.5	9.0	11.0	13.0	14.0
.48	9.0	9.0	9.0	11.0	12.0	14.0
.53	9.0	8.0	9.0	10.5	12.0	11.0
.60	8.0	9.0	9.0	9.5	-----	11.0
.64	-----	-----	8.0	8.0	-----	10.0
.68	-----	-----	-----	-----	-----	8.0



NACA 16-709



NACA 16-715

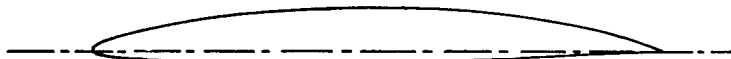

NACA 16-509

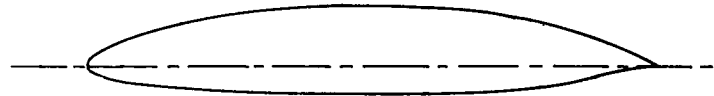

NACA 16-515



NACA 16-209

NATIONAL ADVISORY
COMMITTEE FOR AERONAUTICS

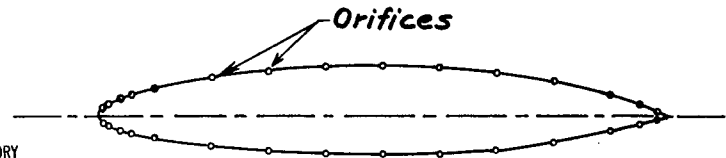

NACA 16-215

Figure 1.- Airfoil profiles tested and distribution of pressure orifices.

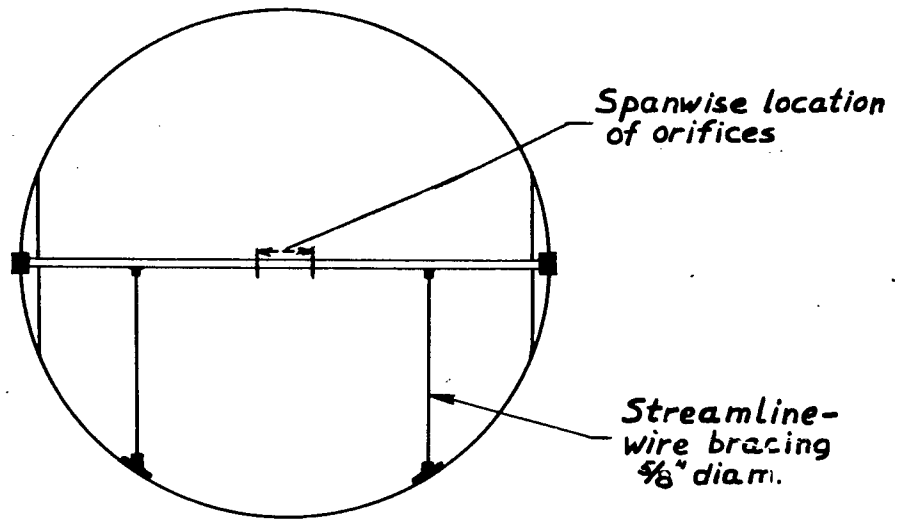

(a) Airfoil mounting in tunnel.

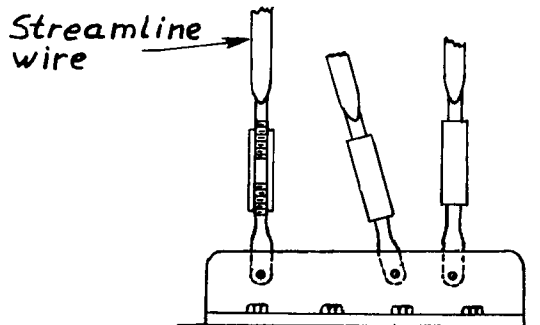
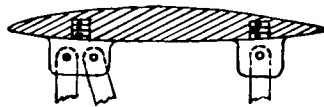

NATIONAL ADVISORY
COMMITTEE FOR AERONAUTICS

(b) Detail of bracing.

Figure 2 .- Diagrammatic sketch of airfoil mounting and bracing in the Langley 8-foot high-speed tunnel.

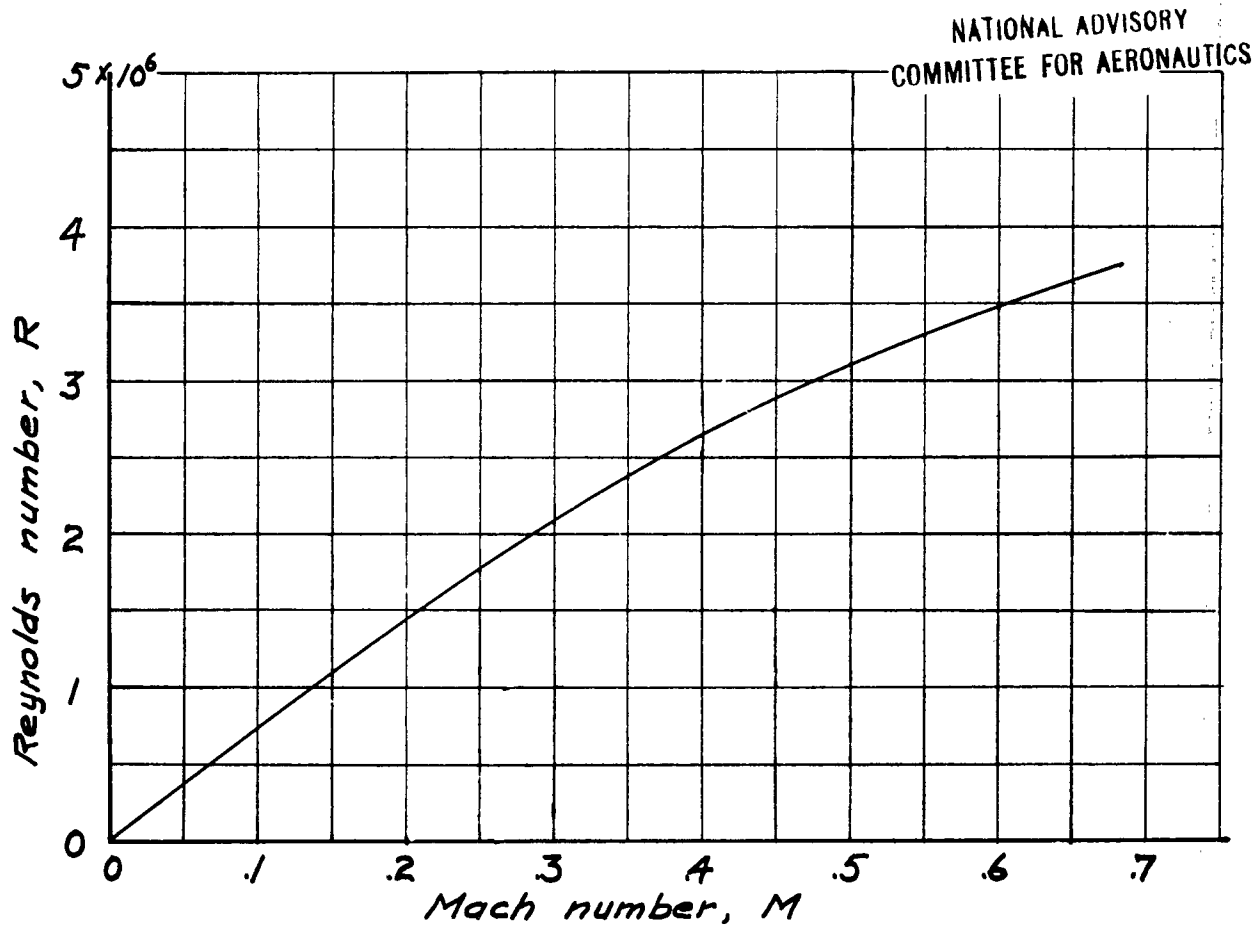

Figure 3.— Variation of Reynolds number (approx.) with Mach number for 1-foot-chord airfoils in the Langley 8-foot high-speed tunnel.

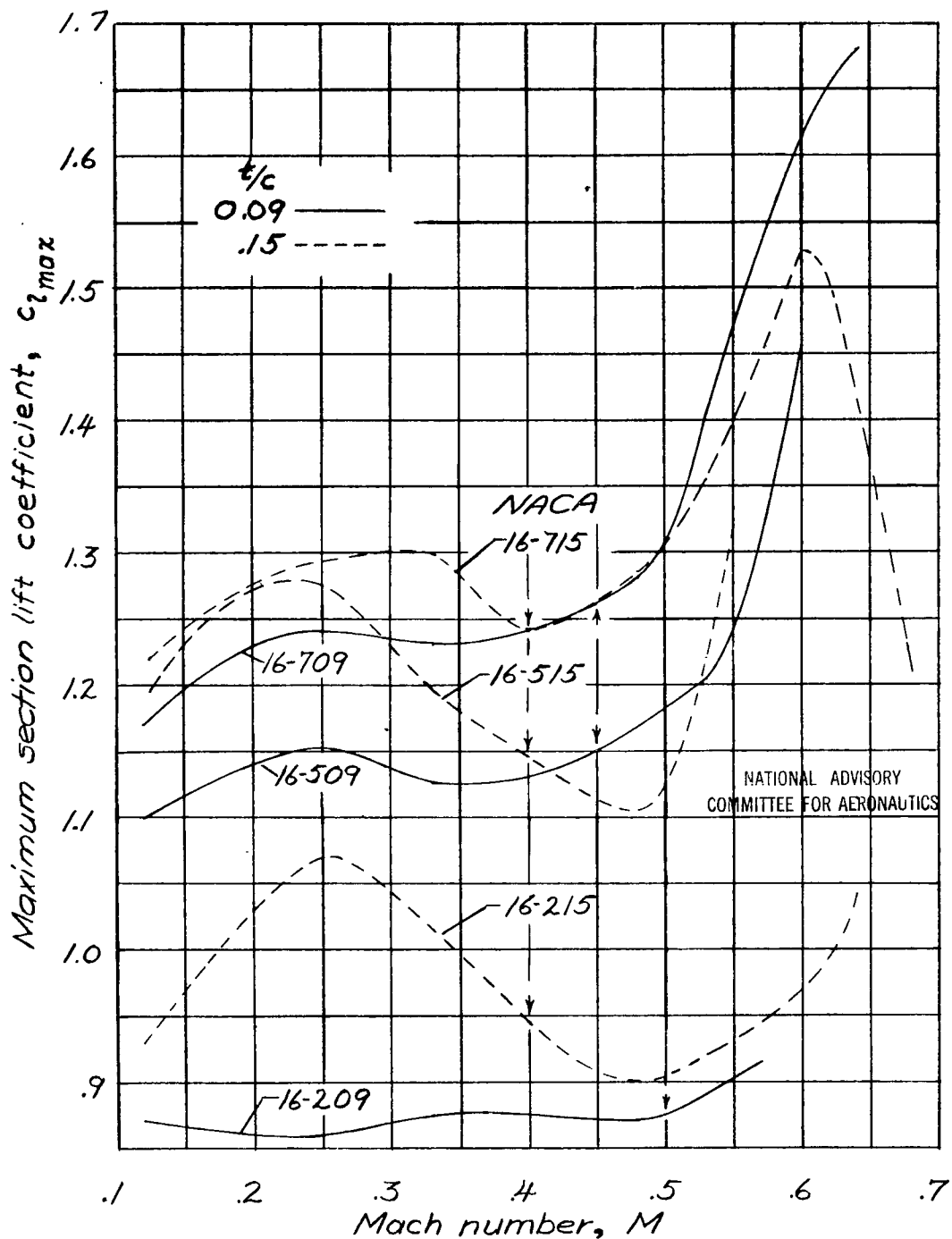

Figure 4.- Variation of maximum section lift coefficient with Mach number for six 1-foot-chord NACA 16-series airfoils.

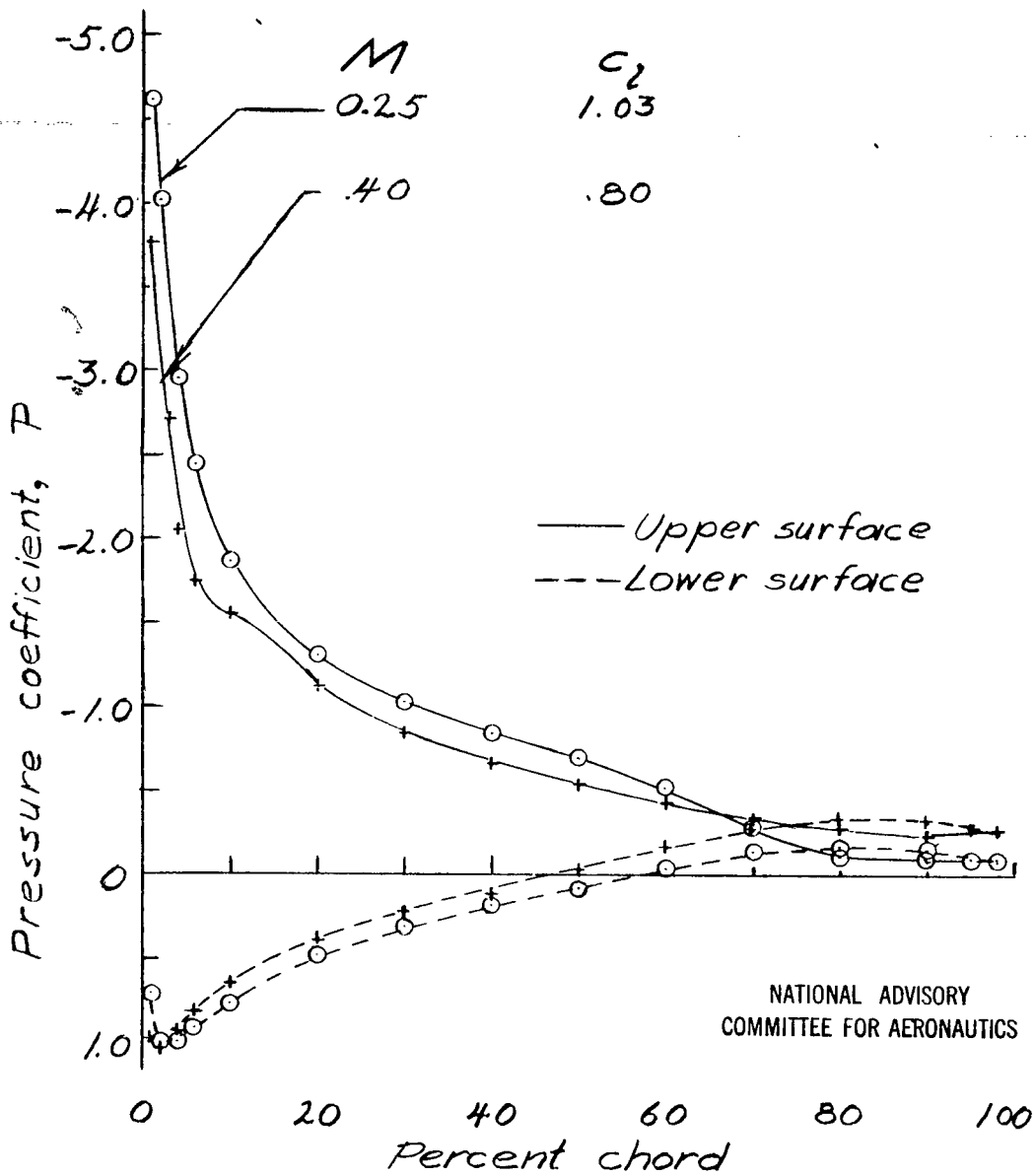

Figure 5.- Pressure distribution over the NACA 16-215 airfoil at an angle of attack of 13° at Mach numbers of 0.25 and 0.40.

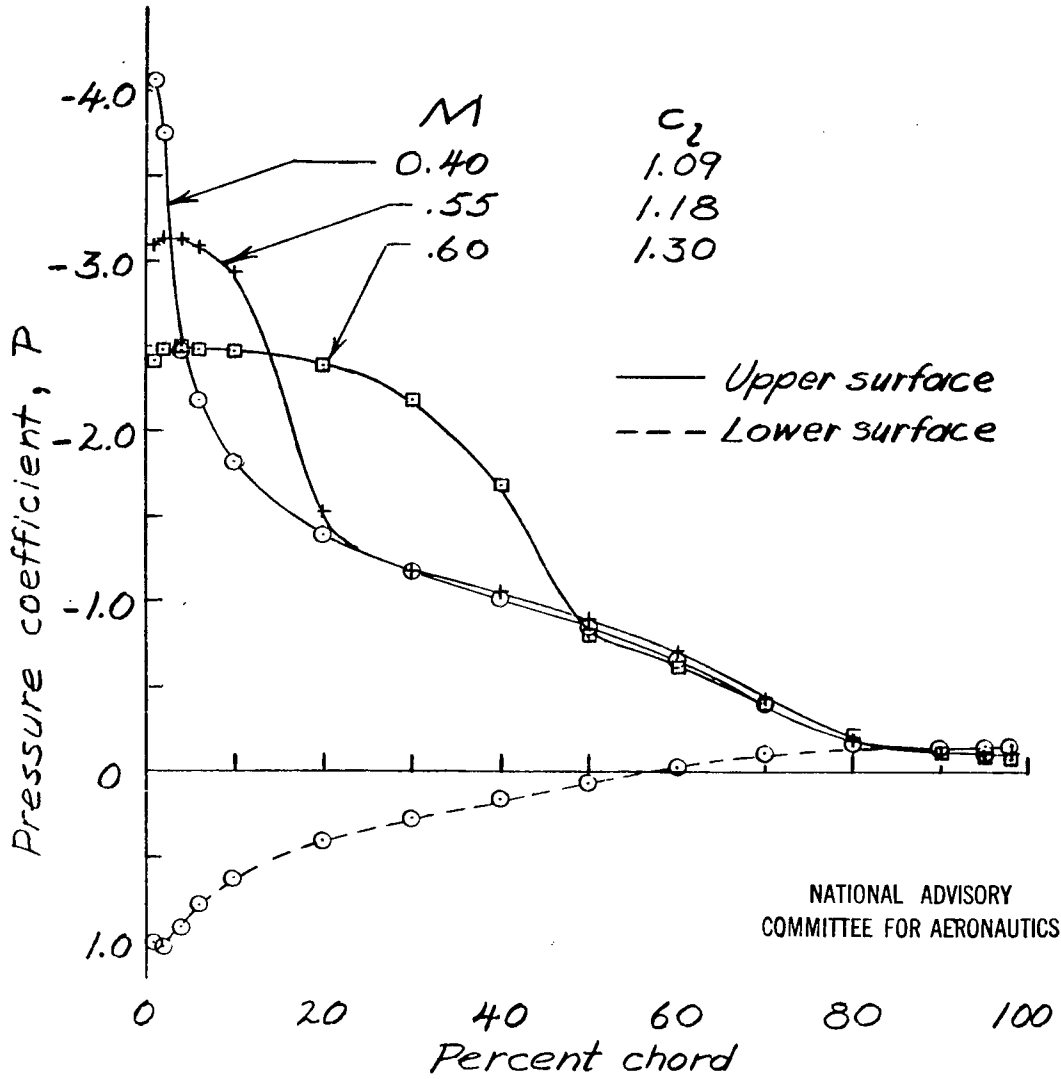

Figure 6.- Pressure distribution over the NACA 16-515 airfoil at an angle of attack of 11° at Mach numbers of 0.40, 0.55, and 0.60.

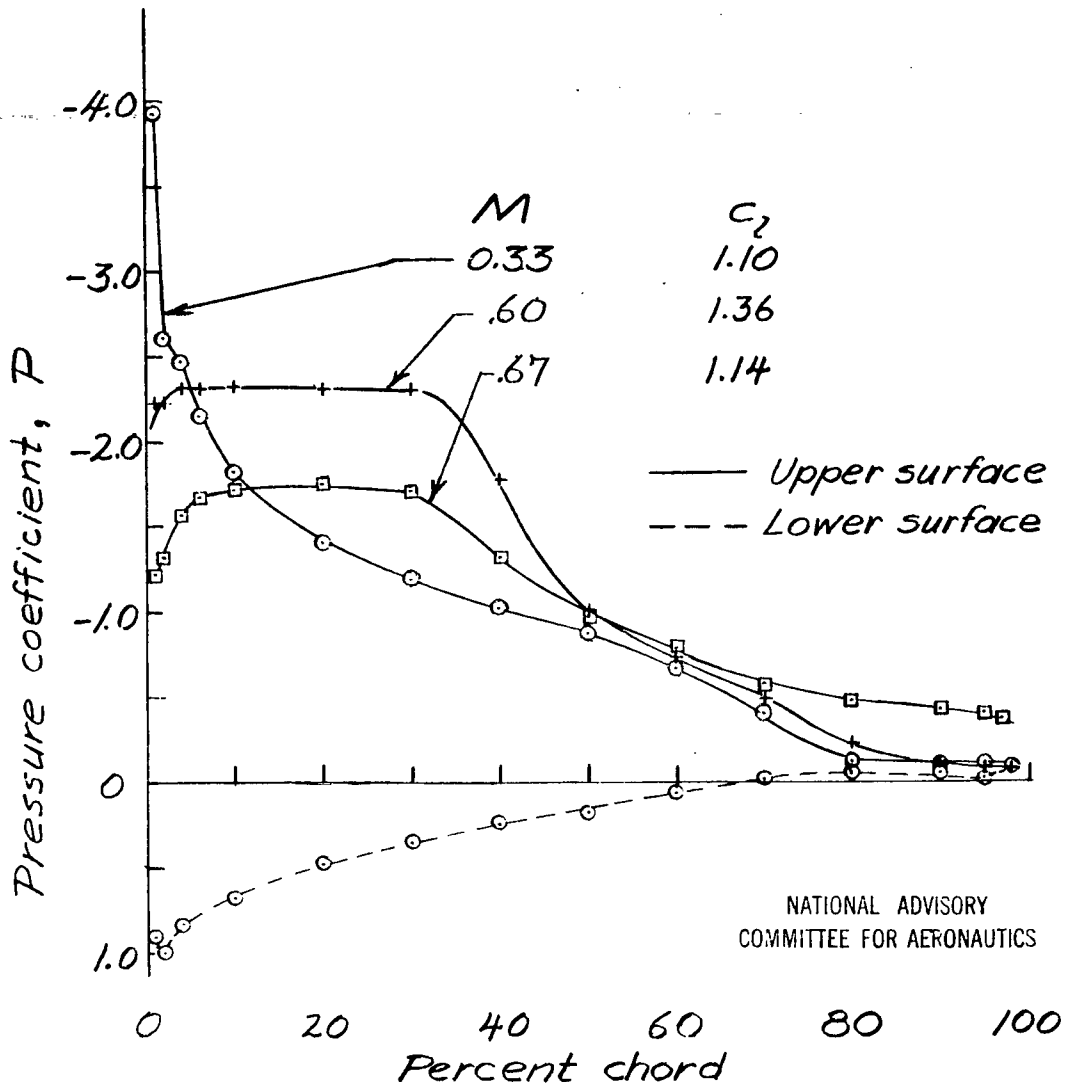

Figure 7.- Pressure distribution over the NACA 16-715 airfoil at an angle of attack of 10° at Mach numbers of 0.33, 0.60, and 0.67.

