

L-65

RB No. LAE23

NATIONAL ADVISORY COMMITTEE FOR AERONAUTICS

# WARTIME REPORT

ORIGINALLY ISSUED

May 1944 as

 Bulletin LAE23

AN AUTOMATICALLY VARIABLE CONTROL LINKAGE AND ITS EFFECT

ON THE LATERAL-CONTROL CHARACTERISTICS

OF A HIGH-SPEED FIGHTER AIRPLANE

By Harry E. Murray and Clarence L. Gillis

Langley Memorial Aeronautical Laboratory  
Langley Field, Va.

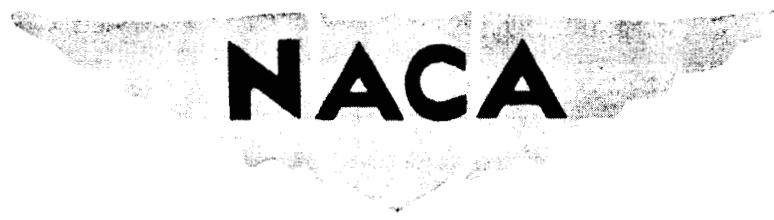

WASHINGTON

NACA WARTIME REPORTS are reprints of papers originally issued to provide rapid distribution of advance research results to an authorized group requiring them for the war effort. They were previously held under a security status but are now unclassified. Some of these reports were not technically edited. All have been reproduced without change in order to expedite general distribution.

NATIONAL ADVISORY COMMITTEE FOR AERONAUTICS

~~SECRET~~ BULLETIN

AN AUTOMATICALLY VARIABLE CONTROL LINKAGE AND ITS EFFECT  
ON THE LATERAL-CONTROL CHARACTERISTICS  
OF A HIGH-SPEED FIGHTER AIRPLANE

By Harry E. Murray and Clarence L. Gillis

SUMMARY

An analysis and a preliminary design were made for a control linkage that varies automatically with dynamic pressure. This device can provide greater lateral control than a fixed control linkage at all but one airspeed without additional aerodynamic balance. The mechanical construction should present no unusual problems and both the weight and volume of the device appear sufficiently small for use in single-seat fighter airplanes as well as in large machines.

INTRODUCTION

The mechanical advantage of aileron control systems in fighter airplanes has necessarily been a compromise between the control requirements at high and at low speeds; the airplane has therefore had its optimum control characteristics occurring in the middle speed range. In contrast with such a compromise, the critical control conditions occur at minimum speed, when the airplane is close to the ground and probably poorly trimmed, and at high speed under fighting conditions. It is consequently desirable that the control characteristics of fighter airplanes be made more nearly optimum throughout the speed range.

If the optimum control at any speed is to be realized, it is necessary that the mechanical advantage of the control system be varied automatically with speed without perceptible lag and independent of stick force, stick position, and normal acceleration. The present paper presents an estimate of the lateral-control characteristics

of an airplane equipped with a variable control linkage capable of such a variation in mechanical advantage. A preliminary design for the device is included.

Although the present analysis deals only with lateral control, somewhat similar problems exist in longitudinal and directional control; and the variable control linkage can probably be expected to render a similar improvement when applied to the elevator or rudder.

### SYMBOLS

q	dynamic pressure
A	area of dynamic-pressure piston
F	force on dynamic-pressure piston ( $qA$ )
X	linear displacement of dynamic-pressure piston
I	number of effective coils of spring on dynamic-pressure piston
L	length of stick from pivot to push-rod link
$F_0$	preload on spring of dynamic-pressure piston
$L_0$	length of stick below pivot when $F = F_0$
d	diameter of wire of which spring is wound
D	diameter of helical spring
J	torsional modulus of elasticity of spring wire
$\delta$	aileron deflection, degrees
$\theta_s$	stick deflection, degrees
$\frac{\theta_s}{\delta}$	control-system mechanical advantage
$l_s$	stick length
$F_s$	stick force

$p$	rolling angular velocity, radians per second (plotted in degrees per second to conform with usual practices)
$b$	span of airplane wing
$V$	forward velocity, feet per second
$\frac{pb}{2V}$	wing-tip helix angle of airplane in roll, radians
$C_l$	rolling-moment coefficient
$C_{l\delta}$	rate of change of rolling-moment coefficient with aileron deflection
$C_{lp}$	rate of change of rolling-moment coefficient with $\frac{pb}{2V}$
$C_h$	hinge-moment coefficient
$C_{h\delta}$	rate of change of hinge-moment coefficient with aileron deflection
$b_a$	aileron span
$\bar{c}_a$	aileron root-mean-square chord
$\rho$	density of air, pound-seconds <sup>2</sup> per foot <sup>4</sup>
$k_s$	spring constant per coil of helical spring
$\Delta p$	pressure difference across dynamic-pressure piston
$C_1, C_2, C_3$	constants used in determination of spring characteristics
$K_0 \dots K_{17}$	constants used in determination of lateral-control characteristics

#### BASIC ASSUMPTIONS AND CONDITIONS FOR THE ANALYSIS

The analysis of the effect of the variable control linkage is made on the basis of the following assumptions:

- (1) The airplane has a rigid wing and control system

- (2) The aileron hinge-moment characteristics are linear with both deflection and angle of attack
- (3) The aileron effectiveness is constant

The first assumption is strictly true only for low speeds, and the second and third hold for small aileron deflections; however, the accuracy is sufficient to give a preliminary prediction of the effect of the variable linkage.

The effect of the variable linkage on an airplane having the geometric characteristics and performance of the P-51, which was chosen as a representative fighter airplane, was studied. The slope of the dynamic hinge-moment curve  $C_{h\delta}$  and the ratio  $\frac{C_{l\delta}}{C_{lp}}$  for the P-51 airplane were estimated to be the following:

$$C_{h\delta} = -0.00129$$

$$\frac{C_{l\delta}}{C_{lp}} = 0.0025 \text{ radian per degree}$$

All computations were made subject to the following geometric characteristics of the P-51 airplane:

Wing:

Area, square feet .....	235.75
Span, feet .....	37.03
Root chord, inches .....	103.99
Tip chord, inches .....	50.00
Taper ratio .....	0.45
Aspect ratio .....	5.815

Aileron:

Area, square feet .....	6.70
Span, feet .....	6.95
Chord, percent wing chord .....	13.7
Deflection, degrees .....	±25
Distance from center line to outboard end, semispan .....	0.965
Distance from center line to inboard end, semispan .....	0.610
Root-mean-square chord, square foot .....	0.923

## Stick:

Travel, inches at top .....	18
Length, inches .....	23
Total deflection, degrees .....	45

EFFECT OF VARIABLE LINKAGE ON LATERAL-CONTROL  
CHARACTERISTICS OF A HIGH-SPEED FIGHTER AIRPLANE

In order that the control system of an airplane be at an optimum mechanical advantage, the maximum allowable stick force should always occur at the maximum stick deflection. If such a condition is to exist throughout a range of speed and atmospheric density, the mechanical advantage of the control system must vary directly as the square root of the dynamic pressure.

Equations for determination of lateral-control characteristics of an airplane equipped with a fixed control linkage and the optimum variable control linkage have been derived by the usual method and are presented in appendix A for the conditions of no limitations and the limitations of maximum stick deflection, stick force, and aileron deflection. Formulas for the constants involved in these equations are also presented. The lateral-control characteristics shown in figures 1 and 2 were obtained from these equations.

The estimated lateral-control characteristics for a 50-pound stick force at full stick deflection of a high-speed fighter equipped with a variable linkage are shown in figure 1. For comparison, these characteristics of the same airplane equipped with a fixed control linkage such that the maximum rolling angular velocity occurs at about  $0.8V_{max}$  are also given. Because the average maximum force exerted by pilots appears to be approximately 50 pounds, the estimation was made on this basis; however, a 50-pound stick force is not developed on the part of the curves where aileron movement is limited by maximum aileron deflection. From figure 1 it can be seen that the variable control linkage provides more lateral control than the fixed control linkage at all but one airspeed at any altitude.

The effect of a variation of the stick force exerted by the pilot rather than of altitude is shown in figure 2, which presents lateral-control characteristics

similar to those of figure 1. When this stick force is greater than 50 pounds, figure 2 shows both the rolling velocity and the helix angle to be independent of stick force on the variable control linkage. Similarly, the loads on the wing and ailerons resulting from aileron deflection are independent of stick forces greater than 50 pounds at any speed.

With a fixed control linkage the wing and ailerons are designed to sustain some maximum load, which corresponds to a certain constant stick force and, at high speed, to a stick deflection less than maximum. If the ailerons tend to overbalance at high speeds or if the strength of the pilot is excessive, deflections and loads beyond design values will occur with this system.

When the automatically variable linkage is used, the maximum possible aileron deflection decreases with speed and is determined not by a stop at the aileron but by maximum stick deflection. This maximum stick deflection then corresponds, for any speed, to a definite load which cannot be exceeded regardless of the strength of the pilot or any tendency of the ailerons to overbalance.

#### PRELIMINARY DESIGN OF A DEVICE TO ACCOMPLISH THE REQUIRED LINKAGE VARIATION

A mechanism for electrically varying the stick mechanical advantage and a control unit for relating the mechanical advantage to the dynamic pressure according to the characteristics of the spring located in back of the dynamic-pressure piston are shown schematically in figure 3. This control unit supplies power to a reversible direct-current motor through the breaker points which are moved, by means of a flexible cable, a distance proportional to the linear displacement of the variable link. Such an electrical system (fig. 3) for varying the control linkage has no extremely delicate or complicated parts and should operate quite reliably without perceptible lag, as does a similar but more complicated mechanism for varying the pitch of constant-speed propellers.

The pressure cell shown in figure 3 was mounted with its axis parallel to the lateral axis of the airplane in

order that the effect of inertia forces resulting from normal and longitudinal accelerations might be eliminated. It is conceivable that such a device might hunt, in which case a brake could easily be installed as indicated in figure 3.

If this mechanism is to produce a variation in mechanical advantage directly proportional to the square root of the dynamic pressure, the length of the lever arm  $L$  (fig. 4) of the aileron push-rod link must vary inversely as the square root of the dynamic pressure. The dynamic-pressure piston must thus move according to the following relation, which is developed in appendix B:

$$F = \frac{C_3}{(C_2 - X)^2} \quad (1)$$

In order that such a force-deflection relation shall exist with the constant-diameter-coil spring shown in figure 3, the number of coils in the spring must vary with deflection as follows:

$$I = \frac{k_s X (C_2 - X)^2}{C_3 - F_0 (C_2 - X)^2} \quad (2)$$

If the relations shown in figure 4 between the constants and variables involved in the link system are used, the constants of equations (1) and (2) can be evaluated, as explained in appendix B. Physically, such a variation in the number of effective coils of a spring can be achieved with a constant-diameter helical spring by variation of the helix angle along the length in order that the coils of the spring will gradually fall against each other as the spring is compressed; the effective number of coils are thereby decreased according to the relation given. Typical curves of the force and the shortening characteristics of the spring fulfilling these relations are shown in figure 5. Although only the constant-diameter helical spring was considered in this analysis, the same characteristics can be obtained from any one of several other springs.

No special power supply is required by either the motor or the control unit; hence, it has been estimated



that the entire device can be installed in a high-speed fighter for an additional weight of about 10 pounds. If, however, the power supply failed or the mechanism became damaged by gunfire, the pilot might conceivably be left in the high mechanical-advantage range without sufficient aileron deflection to make a safe landing. A manual method of operation may therefore be required in case of an emergency.

The additional lateral control made available by the variable linkage will result in an additional wing torsional load which increases with speed. If, at speeds near terminal velocity, the additional loads become undesirably large they can be reduced by reducing the stiffness factors of the dynamic-pressure spring and, consequently, the available aileron deflections corresponding to these speeds.

Because of the improvement in lateral control indicated by the analysis and of the simplicity of the required mechanism, it is suggested that the automatically variable control linkage be tested in flight.

### CONCLUSIONS

From an analytical investigation of the effects of a variable control linkage on the lateral-control characteristics of a fighter airplane and from a preliminary design of this device, the following conclusions are indicated:

1. The automatically variable control linkage can provide more lateral control than a fixed linkage at all but one airspeed without additional aerodynamic balance.

2. When the automatically variable control linkage is used, the design loads can be made to occur at maximum stick deflection, which corresponds to a constant stick force within the limit of the pilot's strength. Further aileron deflection with a corresponding overloading of the structure cannot therefore result from excessive pilot strength or a tendency of the ailerons to overbalance at high speeds.

3. A manual method of operation may be required in the link-variation mechanism in case of a power failure or mechanical difficulties.

4. The device has no extremely delicate or complicated parts, should operate without perceptible lag, and probably can be installed in a high-speed fighter airplane for an additional weight of about 10 pounds.

#### SUGGESTION FOR FUTURE RESEARCH

Inasmuch as the conclusions indicate that definite improvements in lateral control may be expected from the use of a variable control linkage, it is recommended that such a unit be constructed, installed in an airplane, and tested in flight.

Langley Memorial Aeronautical Laboratory,  
National Advisory Committee for Aeronautics,  
Langley Field, Va.

## APPENDIX A

## LATERAL-CONTROL CHARACTERISTICS

The basic formulas for computing the lateral-control characteristics may be conveniently tabulated as follows:

Lateral-control characteristics	No limitations	$\theta_s = \theta_{s_{\max}}$	$F_s = F_{s_{\max}}$	$\delta = \delta_{\max}$
Fixed control linkage; $\delta/\theta_s = K_0$				
$F_s$	$\frac{\rho K_5 \delta v^2}{2}$	$\frac{\rho K_7 v^2}{2}$	$K_{10}$	$\frac{\rho K_{15} v^2}{2}$
$\frac{pb}{2V}$	$K_1 \delta$	$K_8$	$K_{12}/\frac{\rho}{2} v^2$	$K_{16}$
$p$	$K_2 \delta v$	$K_9 v$	$K_{13}/\frac{\rho}{2} v$	$K_{17} v$
Variable control linkage; $\delta/\theta_s = K_0/\sqrt{q}$				
$F_s$	$K_5 \delta v \sqrt{\frac{\rho}{2}}$	$K_7$	$K_{10}$	$K_{15} v \sqrt{\frac{\rho}{2}}$
$\frac{pb}{2V}$	$K_1 \delta$	$K_8/v \sqrt{\frac{\rho}{2}}$	$K_{12}/v \sqrt{\frac{\rho}{2}}$	$K_{16}$
$p$	$K_2 \delta v$	$K_9/\sqrt{\frac{\rho}{2}}$	$K_{13}/\sqrt{\frac{\rho}{2}}$	$K_{17} v$

The constants  $K_0 \dots K_{17}$  may be evaluated from the following relations:

$K_0$  constant depending upon aileron-stick linkage

$$K_1 = \frac{C_{l\delta}}{C_{lp}} \quad K_8 = K_1 K_0 \theta_{s_{\max}} \quad K_{13} = \frac{K_{10} K_2}{K_5}$$

$$K_2 = \frac{2}{b} K_1 \quad K_9 = K_2 K_0 \theta_{s_{\max}} \quad K_{15} = K_5 \delta_{\max}$$

$$K_5 = \frac{1}{l_s} C_{h\delta} b a \bar{c}_a^2 K_0 \quad K_{10} = F_{s_{\max}} \quad K_{16} = K_1 \delta_{\max}$$

$$K_7 = K_5 K_0 \theta_{s_{\max}} \quad K_{12} = \frac{K_{10} K_1}{K_5} \quad K_{17} = K_2 \delta_{\max}$$

## APPENDIX B

## DETERMINATION OF CONSTANTS FOR SPRING EQUATIONS

From figure 4 it can be seen that

$$L = L_0 - c_1 X$$

If the mechanical advantage is to vary directly as the square root of the dynamic pressure, however, the following condition must be true:

$$\begin{aligned} L &= \frac{K_0}{\sqrt{q}} \\ &= L_0 - c_1 X \end{aligned}$$

and, therefore,

$$\begin{aligned} F &= qA \\ &= \frac{C_3}{(C_2 - X)^2} \end{aligned}$$

where

$$\begin{aligned} C_2 &= \frac{L_0}{c_1} \\ C_3 &= \left(\frac{K_0}{c_1}\right)^2 A \end{aligned}$$

For a helical spring

$$F = \left(\frac{k_s}{I}\right)X + F_0$$

where

$$k_s = \frac{d^4 J}{8D^3}$$

From these conditions

$$I = \frac{k_s X}{F - F_0}$$

or

$$I = \frac{k_s X (C_2 - X)^2}{C_3 - F_0 (C_2 - X)^2}$$

Figure 5 shows a typical curve of  $I$  plotted against  $X$  and a corresponding curve of  $F$  plotted against  $X$  for the following numerical values of the constants:

$$C_2 = 4$$

$$C_3 = 4$$

$$k_s = 4$$

Figure 5 represents no particular setup, however, and is given only as an example, because  $C_2$ ,  $C_3$ , and  $k_s$  will depend upon the dimensions of the device designed and the properties of the spring.

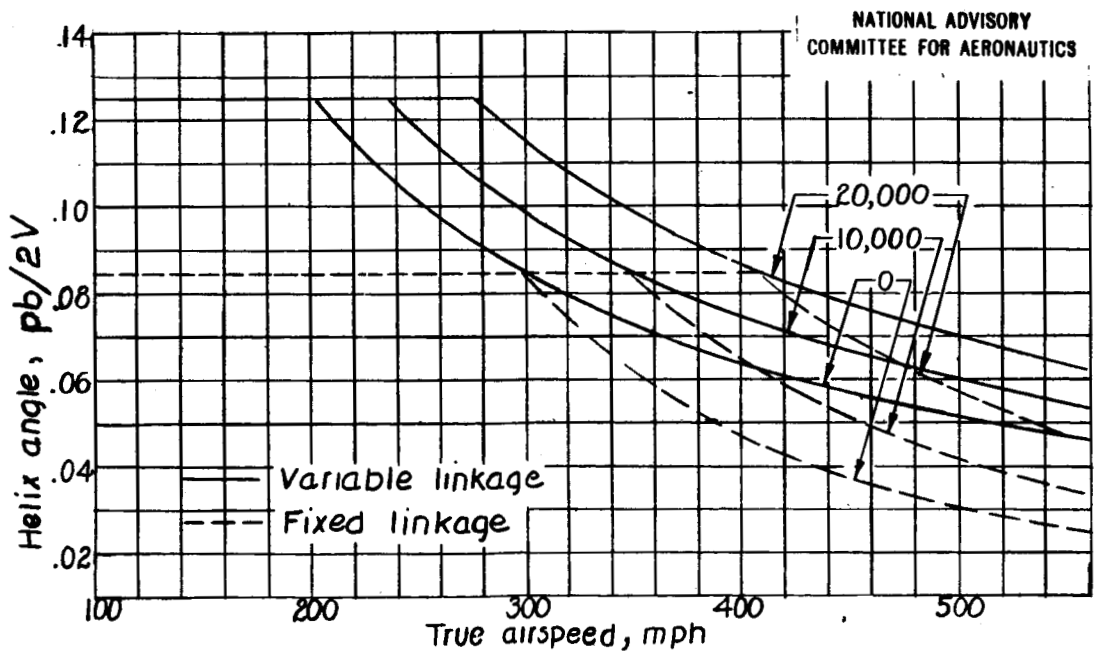
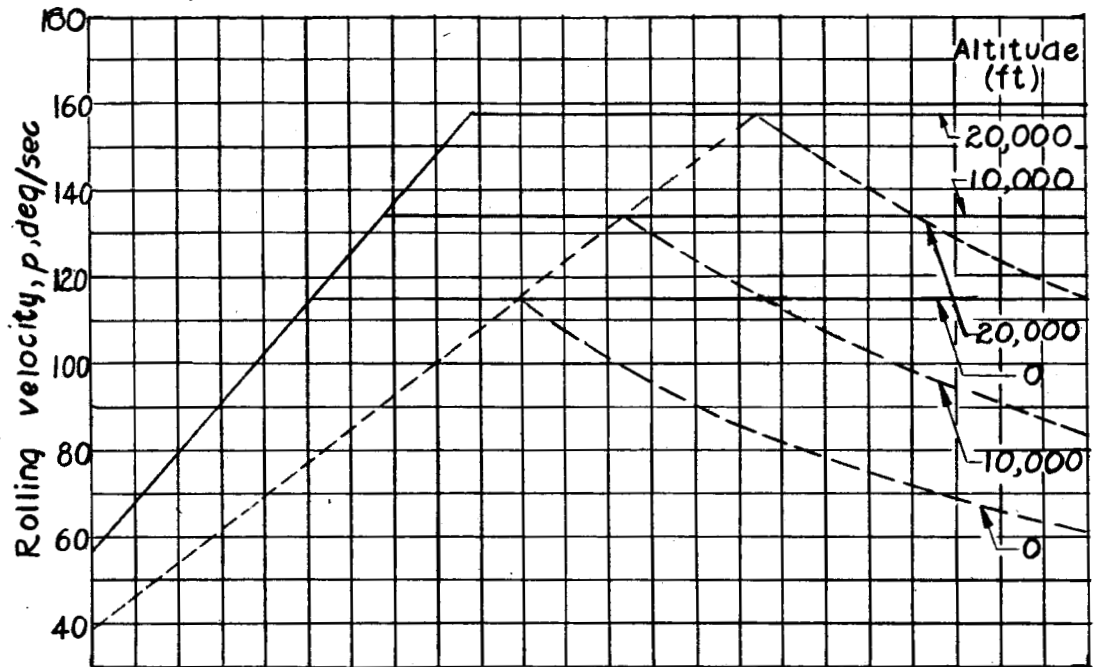
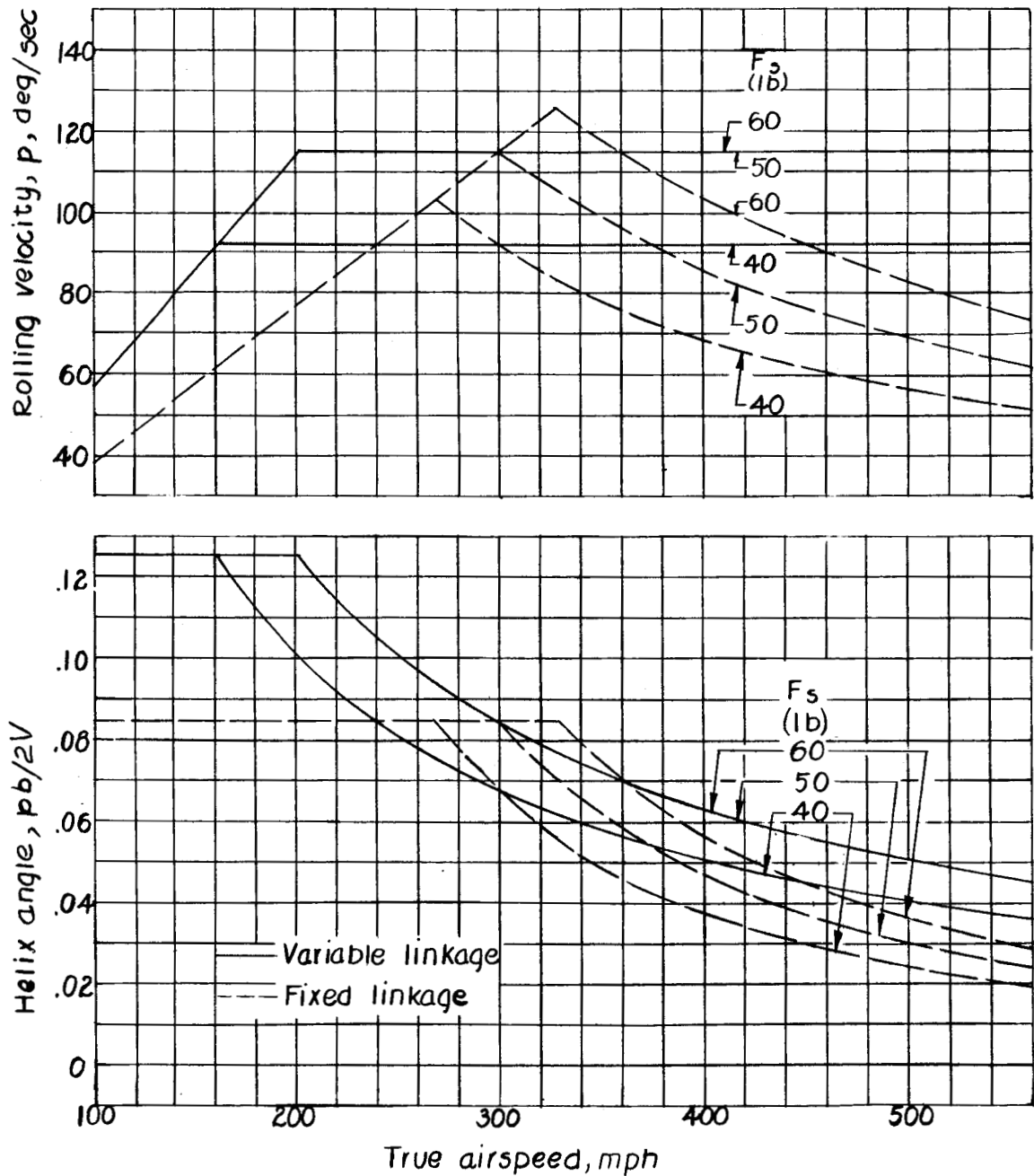

Figure 1.-Lateral-control characteristics of a high-speed fighter airplane having fixed and variable linkages at three altitudes with a maximum stick force of 50 pounds.



NATIONAL ADVISORY  
COMMITTEE FOR AERONAUTICS

Figure 2.-Lateral-control characteristics of a high-speed fighter airplane having fixed and variable linkages at sea level with three stick forces. Maximum stick deflection occurs with the variable linkage when  $F_s = 50$  pounds.

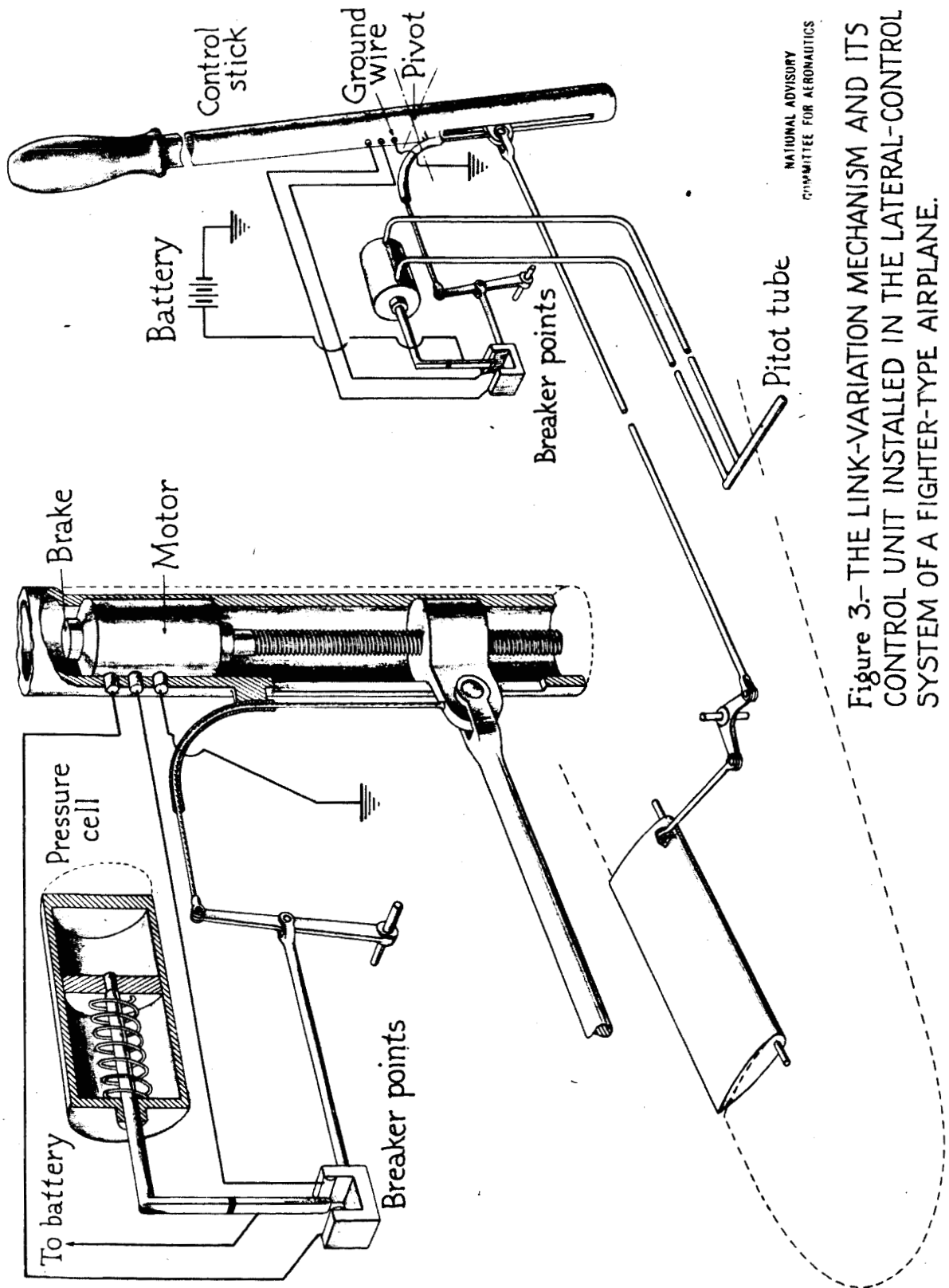
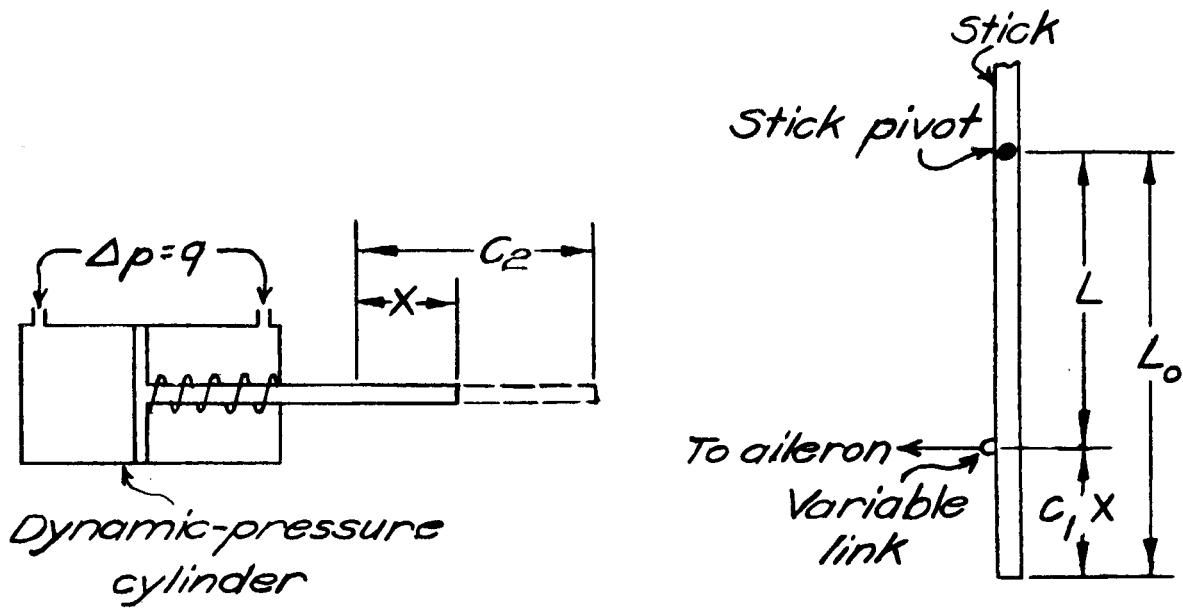

Figure 3.—THE LINK-VARIATION MECHANISM AND ITS CONTROL UNIT INSTALLED IN THE LATERAL-CONTROL SYSTEM OF A FIGHTER-TYPE AIRPLANE.

NATIONAL ADVISORY  
COMMITTEE FOR AERONAUTICS





NATIONAL ADVISORY  
COMMITTEE FOR AERONAUTICS.

Figure 4.-The relation between the displacement of the dynamic-pressure piston and the location of the variable link.

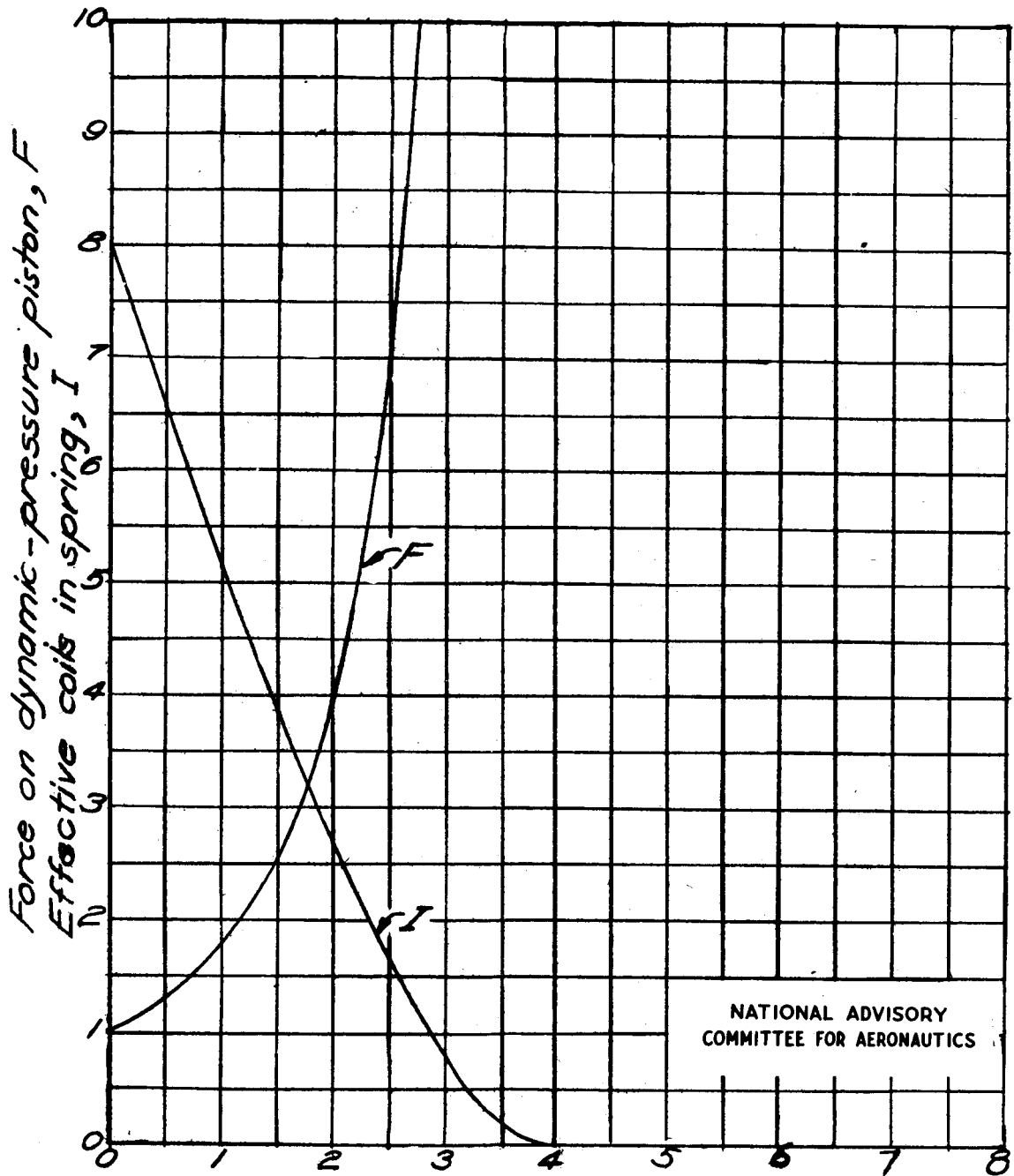

NATIONAL ADVISORY  
COMMITTEE FOR AERONAUTICS

Displacement of dynamic-pressure piston,  $X$   
Figure 5.-Typical force and shortening characteristics of dynamic-pressure spring